



April 29, 2021
LIC-21-0004

U. S. Nuclear Regulatory Commission
ATTN: Document Control Desk
Washington, DC 20555

Fort Calhoun Station, Unit No. 1
Renewed Facility Operating License No. DPR-40
NRC Docket No. 50-285

Subject: Fort Calhoun Station (FCS) Radiological Effluent Release Report and Radiological Environmental Operating Report

References: FCS Permanently Defueled Technical Specifications (PDTs) Sections 5.9.4(a) and 5.9.4(b)

Pursuant to Fort Calhoun Station (FCS), Unit No. 1, Permanently Defueled Technical Specifications (PDTs), Sections 5.9.4(a), and 5.9.4(b), Omaha Public Power District (OPPPO) provides the Annual Radiological Effluent Release Report and the Annual Radiological Environmental Operating Report.

The Annual Radiological Effluent Release Report is submitted in accordance with PDTs 5.9.4(a) and encompasses the period of January 1, 2020 through December 31, 2020. The report is presented in the format outlined in Regulatory Guide 1.21, Revision 1. In addition, the report provides the results of quarterly dose calculations performed in accordance with the Offsite Dose Calculation Manual (ODCM). In accordance with PDTs Section 5.17(d), Section VII of the Annual Radiological Effluent Release Report includes the revisions to the ODCM made during this period. Section VII of the Annual Radiological Effluent Release Report also includes Process Control Program (PCP) changes made during this period.

The Annual Radiological Environmental Operating Report is submitted in accordance with PDTs 5.9.4(b) and encompasses the period of January 1, 2020 through December 31, 2020.

No commitments to the NRC are contained in this letter.

U. S. Nuclear Regulatory Commission
LIC-21-0004
Page 2

Please contact Mrs. Andrea K. Barker at (531) 226-6051 or (402) 917-7207 if you should have any questions.

Respectfully,

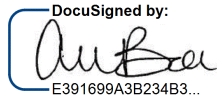
DocuSigned by:

E391699A3B234B3...

Andrea K. Barker
Regulatory Assurance & Emergency Planning Manager,

AKB/cac

Enclosures:

1. Annual Radiological Effluent Release Report
2. Annual Radiological Environmental Operating Report

c: S. A. Morris, NRC Regional Administrator, Region IV
J. D. Parrott, NRC Senior Project Manager
C. D. Steely, NRC Senior Health Physicist, Region IV

**Omaha Public Power District
Fort Calhoun Station Unit No. 1**

Annual Radioactive Effluent Release Report (ARERR)

January 1, 2020 to December 31, 2020

DOCKET NO. 50-285

OPERATING LICENSE DPR-40

Annual Radiological Effluent Release Report

This report is submitted for the period January 1, 2020 through December 31, 2020. The Effluent Report is presented in the format outlined in Regulatory Guide 1.21, Revision 2.

In addition, this report provides the results of quarterly dose calculations performed in accordance with the Offsite Dose Calculation Manual. Results are presented by quarter for the period January 1, 2020 through December 31, 2020.

Descriptions of any changes made during the preceding twelve months to the Offsite Dose Calculation Manual and/or the Process Control Program for the Fort Calhoun Station are presented.

DocuSigned by:

7BF6365F747D40C...

Plant Manager Decommissioning

TABLE OF CONTENTS

<u>Section</u>	<u>Section Title</u>
I.	1.0 Introduction
	1.1 Executive Summary
	2.0 Supplemental Information
	2.1 Regulatory Limits
	2.2 Effluent Concentration Limits
	2.3 Measurements and Approximations of Total Radioactivity
	2.4 Estimation of Total Percent Error
	2.5 Batch Releases
	2.6 Abnormal Releases
	3.0 Gaseous Effluents
	4.0 Liquid Effluents
	5.0 Solid Wastes
	6.0 Related Information
	6.1 Operability of Liquid and Gaseous Monitoring Instrumentation
	6.2 Changes to Off-site Dose Calculation Manual (ODCM), CH-ODCM-0001 or Process Control Program, FCSD-RW-PG-101
	6.3 New Locations or Modifications for Dose Calculations or Environmental Monitoring
	6.4 Noncompliance with Radiological Effluent Control Requirements
	6.5 Modifications to Liquid and Gaseous Waste Treatment and Ventilation Exhaust Systems
	6.6 Meteorological Monitoring Program
	6.7 Assessment of Doses
	6.8 Groundwater Monitoring Program and Observations
II.	Quarterly Doses from Effluents, Offsite Dose Calculation Manual

TABLE OF CONTENTS

III. Radiological Effluent Releases

Table III.1; Batch Liquid and Gas Release Summary
Table III.2; Abnormal Batch Liquid and Gaseous Release Summary
Table III.3; Gaseous Effluents - Summation of All Releases
Table III.4; Gaseous Effluent Releases - Batch Mode
Table III.5; Gaseous Effluent Releases - Continuous Mode
Table III.6; Liquid Effluents - Summation of All Releases
Table III.7; Liquid Effluent Releases - Batch Mode
Table III.8; Liquid Effluent Releases - Continuous Mode
Table III.9; Groundwater Analysis Results

IV. Dose From Gaseous Effluents - GASPAR II Output

Tables IV-A-1 through IV-A-36 - Receptor Dose Projections
Table IV-B-1 - Dose Contributions at Unrestricted Area Boundary
Table IV-C-1 - ALARA Annual Integrated Dose Summary

V. Dose From Liquid Effluents - LADTAP II Output

Summary Dose Projections from Liquid Effluent Releases

VI. Radioactive Effluent Releases-Solid Radioactive Waste

VII. ATTACHMENTS

1. Off-Site Dose Calculation Manual (ODCM) and Process Control Program (PCP) Revisions
2. Joint Frequency Distribution Wind Direction vs. Wind Speed by Stability Class and Meteorological Data

1.0 INTRODUCTION

This Annual Radiological Effluent Release Report, for Fort Calhoun Station Unit No. 1, is submitted for the period January 1, 2020 through December 31, 2020.

1.1 Executive Summary

The Radioactive Effluent Monitoring program for the year 2020 was conducted as described in the following report. Major efforts were made to maintain the release of radioactive effluents to the environment as low as reasonably achievable.

The total airborne activity released from noble gas was 3.68 curies. This was an increase from the 2019 activity of 0.986 curies. This increase was due to releases of Kr-85 during the vacuum drying process of the Dry Cask campaign.

The total airborne activity from I-131, I-133, and particulates with half-lives > 8 days in 2020 was 1.11E-07 curies. This is an increase from the 2019 activity of 0.00 curies. This was due to particulates being identified from decommissioning activities.

The total airborne activity from Tritium was 1.15 curies. This was an increase from the 2019 activity of 0.879 curies. This increase was due to maintaining the Auxiliary Building at a higher temperature than in the past for the Dry Cask campaign, which added to the evaporation of the tritium.

Dose contributions from airborne effluents at the unrestricted area boundary were; 1.26E-04 mRad gamma air dose, 1.43E-02 mRad beta air dose, 1.14E-02 mRem total body dose, and 1.14E-02 mRem critical organ dose. Gamma and beta dose showed an increase from 2019 levels of 2.63E-05 mRad gamma air dose and 2.99E-03 mRad beta air dose, from releasing gases during the Dry Cask campaign. Whole body and critical organ doses increased from 2019 levels of 5.86E-03 mRem total body dose and 5.46E-03 mRem critical organ dose. This increase is due to the increase in the tritium and Kr-85 released.

Total water activity (excluding tritium, dissolved gases, and alpha) released in 2020 in liquid effluents was $5.63\text{E}-03$ curies. This was an increase from the 2019 activity of $9.30\text{E}-04$ curies. This increase was due to a substantial increase in liquid waste generated.

The total water tritium activity released in 2020 in liquid effluents was $3.64\text{E}+00$ curies. This was an increase from the 2019 activity of $9.41\text{E}-01$ curies. This increase was due to a substantial increase in liquid waste generated.

The calculated whole body dose due to liquid effluents at the site discharge from all sources in 2020 was $1.18\text{E}+00$ mRem which was 39.33% of the annual dose limit. This was an increase from the 2019 dose of $9.91\text{E}-02$ mRem, which was 3.30% of the annual dose limit. Dose increased due to an increase in volume released.

The calculated critical organ dose due to liquid effluents at the site discharge from all sources in 2020 was $1.86\text{E}+00$ mRem. This was an increase from the 2019 dose of $1.55\text{E}-01$ mRem. This increase was due to an increase in volume released.

The Fort Calhoun Station meteorological system for the period January 1, 2015 through December 31, 2019 had a cumulative recovery rate of 78.15% from the station meteorological tower with the remaining 21.85% provided by the National Weather Service, for the joint frequency parameters required by Regulatory Guide 1.23 for wind speed, wind direction, and delta temperature. The low recovery rate was due to the loss of the onsite tower from flood damage.

There were no abnormal releases during 2020.

During 2020 there were two changes to the Off-site Dose Calculations Manual (ODCM), CH-ODCM-0001, both on 6/1/2020 and one change to the Process Control Program, FCSD-RW-PG-101, on 12/10/2020.

For 2020, the total volume of solid radwaste released from the unit was $8.45\text{E}+02$ cubic meters. This was an increase from the 669.38 cubic meters of solid waste released from the unit in 2019. The increase was mostly attributed to disposing of the one legacy Steam Generator and an increase in the number of Dry Active Waste shipments.

The total activity released from the unit for 2020 was 3.44E+01 curies, 7.66E-01 curies from Dry Active Waste and 3.37E+01 curies of Other Waste. This was a decrease from the 2019 value of 176.208 curies. Overall, the effluent monitoring program was conducted in a manner to ensure the activity released and dose to the public were maintained as low as reasonably achievable.

2.0 SUPPLEMENTAL INFORMATION

2.1 Regulatory Limits

The ODCM Radiological Effluent Control Specifications applicable to the release of radioactive material in liquid and gaseous effluents are described in the following sections.

2.1.1 Fission and Activation Gases

The release rate of radioactive material in airborne effluents shall be controlled such that the instantaneous concentrations of radionuclides do not exceed the values specified in 10 CFR 20 for airborne effluents at the unrestricted area boundary.

2.1.2 Doses from H-3 and Radioactive Material in Particulate Form with Half Lives Greater than 8 Days (Other than Noble Gases).

- a. The dose to an individual or dose commitment to any organ of an individual in unrestricted areas due to the release of H-3 and radioactive material in particulate form with half-lives greater than eight days (other than noble gases) in airborne effluents shall not exceed 7.5 millirem from all exposure pathways during any calendar quarter.
- b. The dose to an individual or dose commitment to any organ of an individual in unrestricted areas due to the release of H-3 and radioactive materials in particulate form with half-lives greater than eight days (other than noble gases) in airborne effluents shall not exceed 15 millirem from all exposure pathways during any calendar year.

2.1.3 Liquid Effluents

The release rate of radioactive material in liquid effluents shall be controlled such that the instantaneous concentrations for radionuclides do not exceed the values specified in 10 CFR 20 for liquid effluents at site discharge. To support facility operations, RP/Chemistry supervision may increase this limit up to the limit specified in QATR Appendix E, E.2.1.3.b.

QATR Appendix E, E.2.1.3.b establishes the administrative control limit on concentration of radioactive material, other than dissolved or entrained noble gases, released in liquid effluents to unrestricted areas conforming to ten times 10 CFR 20.1001-20.2401, Appendix B, Table 2, Column 2.

The dose or dose commitment to an individual from radioactive materials in liquid effluents released to unrestricted areas shall be limited to:

- a. During any calendar quarter: Less than or equal to 1.5 mRem to the whole body and less than or equal to 5 mRem to any organ, and
- b. During any calendar year: Less than or equal to 3 mRem to the whole body and less than or equal to 10 mRem to any organ.

2.1.4 Total Dose-Uranium Fuel Cycle

The dose to any real individual from uranium fuel cycle sources shall be limited to ≤ 25 mRem to the total body or any organ (except the thyroid, which shall be limited to ≤ 75 mRem) during each calendar year.

2.2 Effluent Concentration Limits (ECL)

2.2.1 Liquid Effluents

The values specified in 10 CFR Part 20, Appendix B, Column 2 are used as the ECL for liquid radioactive effluents released to unrestricted areas.

2.2.2 Gaseous Effluents

The values specified in 10 CFR Part 20, Appendix B, Column 1 are used as the ECL for gaseous radioactive effluents released to unrestricted areas.

2.3 Measurements and Approximations of Total Radioactivity

Measurements of total radioactivity in liquid and gaseous radioactive effluents were accomplished in accordance with the sampling and analysis requirements of Tables 3.1 and 3.2 of Part I of the ODCM.

2.3.1 Liquid Radioactive Effluents

Each batch was sampled and analyzed for gamma emitting radionuclides using gamma spectroscopy, prior to release. Composite samples were analyzed monthly and quarterly for the Monitor Tanks. Composite samples were analyzed monthly in the onsite laboratory for tritium and gross alpha radioactivity, using liquid scintillation and proportional counting techniques respectively. Composite samples were analyzed quarterly for Sr-89, Sr-90, Fe-55, Ni-63, and Gross Alpha by a contract laboratory (Teledyne Brown Engineering, Inc.). A software program was used to project the total body and critical organ dose contribution at the unrestricted area boundary for each release and the percent contribution to the annual objective dose.

2.3.2 Gaseous Radioactive Effluents

Each gaseous batch release was sampled and analyzed for radioactivity prior to release. A software program was developed and installed that can project the total body and critical organ dose contribution at the unrestricted area boundary for each release and the percent contribution to the annual objective dose. This program also adds the projected dose to the current actual dose totals in a temporary file, until it is updated with actual release data at the completion of a purge.

Continuous release effluent pathways were continuously sampled using charcoal and particulate filters and analyzed weekly for gamma emitting radionuclides using gamma spectroscopy. Weekly particulate filters were analyzed for gross alpha radioactivity in the onsite laboratory using proportional counting techniques. Quarterly composites of particulate filters were analyzed for Sr-89, Sr-90, and Gross Alpha by a contract laboratory (Teledyne Brown Engineering, Inc.).

2.4 Estimation of Total Percent Error

The estimated total percent error is calculated as follows:

$$\text{Total Percent Error} = (E_1^2 + E_2^2 + E_3^2 + \dots + E_n^2)^{0.5}$$

Where E_n = percent error associated with each contributing parameter.

Sample counting error is estimated by the Canberra Genie System Software for samples analyzed by gamma spectroscopy. This calculation can include the error associated with peak area determination, gamma ray abundance, efficiency and half-life. Systematic error is estimated for gaseous and liquid effluent analyses and dilution and wastewater volume.

2.5 Batch Releases

A summary of information for liquid and gaseous batch releases is included in Table III.1.

2.6 Abnormal Releases

Abnormal Releases are defined as unplanned and unmonitored releases of radioactive material from the site.

A summary of information for liquid and gaseous abnormal releases is included in Table III.2.

3.0 GASEOUS EFFLUENTS

The quantities of radioactive material released in gaseous effluents are summarized in Tables III.3, III.4 and III.5. All radioactive materials released in gaseous form are considered to be ground level releases.

4.0 LIQUID EFFLUENTS

The quantities of radioactive material released in liquid effluents are summarized in Tables III.6, III.7 and III.8.

5.0 SOLID WASTES

The quantities of radioactive material released as solid effluents are summarized in Section VI.

6.0 RELATED INFORMATION

6.1 Functionality of Liquid and Gaseous Monitoring Instrumentation

During the reporting period there was 1 instrument used to monitor radioactive effluent releases that failed to meet the minimum reportable instrument operability requirements listed in the ODCM during the reporting period.

During the reporting period RM-043, Particulate-Laboratory and Radwaste Processing Building Stack Monitor, was not functional for 64 days (6/28/2020 – 8/31/2020) due to various mechanical issues. During this time period auxiliary sample collection equipment was initiated, allowing the effluent from the ventilation system to be monitored per the ODCM.

6.2 Changes to the Offsite Dose Calculation Manual (ODCM) and/or Process Control Program (PCP)

During 2020 there were two changes to the Off-site Dose Calculations Manual (ODCM), CH-ODCM-0001, both on 6/1/2020 and one change to the Process Control Program, FCSD-RW-PG-101, on 12/10/2020.

- The following changes were made to the ODCM:
 - Use historical average Meteorological data.
 - Created a Forced Draft Ventilation effluent release path.
 - Created an Open Air Demolition effluent release path.
 - Added more background TLD's.
 - Removed Noble Gases as a possible source of activity for releases.
 - Removed C-14 as a possible release source.
 - Changed the PORC to an Independent Safety Review (ISR).
 - Updated Functionality of liquid Effluent Instrumentation requirements to align with the DSAR.
 - Added the Particulate Air Samplers to the reporting criteria for Gaseous Effluent Instrumentation.
 - Administrative changes to be consistent within the ODCM related to the length of the historical data and removing the vague use on how to calculate dose estimates.
- The following changes were made to the PCP:
 - This was reformatted, so revision bars were not used.
 - Responsibilities were more clearly defined and include the D&D waste group.
 - Removed the scope of Liquid Radioactive Waste Processing from the PCP, since it is included in the ODCM. This aligns with NRC Generic Letter 89-01 and NUREG-1301.
 - Updated guidance for solidification to use of a Vendor program.
 - Replaced specific direction for encapsulation, incineration, and use of evaporators, with a 'Special Cases' section in the new PCP.
 - All guidance related to waste characterization and classification removed. D&D waste procedure, "Waste Characterization and Classification" contains all guidance.
 - Removed blending and concentration averaging associated with the Low Level Waste Licensing Branch Technical Position on Radioactive Waste Classification (BTP). D&D waste procedure, "Waste Characterization and Classification" contains all guidance.
 - Revised the required review and approval requirements from Safety Review Committee (SRC) to the Independent Safety Reviewer (ISR). This change aligns with the station's current Quality Assurance Topical Report (QATR).

6.3 New Locations or Modifications for Dose Calculations or Environmental Monitoring

None

6.4 Noncompliance with Radiological Effluent Control Requirements

This section provides a list of any event that did not comply with the applicable requirements of the Radiological Effluent Controls given in the Offsite Dose Calculation Manual (ODCM). Detailed documentation concerning the evaluations and corrective actions is maintained onsite.

6.4.1 Abnormal Gaseous and Liquid Releases

No abnormal releases were made during the calendar year of 2020.

6.4.2 Failure to Meet Specified Sampling Requirements

During 2020, there were no instances in which specified sampling requirements were not met.

6.5 Modifications to Liquid and Gaseous Waste Treatment and Ventilation Exhaust Systems

During the reporting period no design modifications were approved nor implemented involving major changes to the Liquid and Gaseous Waste Treatment Systems.

6.6 Meteorological Monitoring Program

A summary of hourly meteorological data, collected during 2020, is retained onsite and is maintained as documentation as required by Regulatory Guide 1.21 Rev 2. This data is available for review by the Nuclear Regulatory Commission upon request. Joint Frequency tables are included in Section VII, Attachment 2

The 5 year historical Average χ/Q is utilized to determine the concentrations of radionuclides at the unrestricted area boundary. For quarterly estimates during the year an average X/Q is used, which is the highest X/Q calculated using the 5 year's historical meteorological data.

6.7 Assessment of Doses

6.7.1 Doses Due to Liquid Effluents

Total body, skin, and organ dose for liquid releases were calculated in mRem for all significant liquid pathways using the annual configuration of the LADTAP II program. The site discharge location was chosen to present a most conservative estimate of dose for an average adult, teenager, child, and infant. A conservative approach is also presented by the assumption that Omaha and Council Bluffs receive all drinking water from the Missouri River.

The LADTAP II program in its annual configuration was also used to calculate the total body and organ doses for the population of 950,006 within a 50-mile radius of the plant (based on the 2010 census). The results of the calculations are listed in Section V.

The doses due to liquid effluents for total body and critical organ are also calculated quarterly using the methods in the ODCM. The results are listed in Section II.

6.7.2 Doses Due to Gaseous Effluents

Total body, skin and organ doses from ground releases were calculated in mRem to an average adult, teenager, child, and infant in each receptor using the annual configuration of the GASPAR II program. Also, the doses to the same groups, in units of mRad due to gamma and beta radiation carried by air, were computed using GASPAR II.

The GASPAR II program in its annual configuration was also used to calculate the ALARA integrated population dose summary for the total body, skin and organ doses in person-rem for all individuals within a 50-mile radius. The results of the calculations are shown in Section IV.

The doses due to gaseous effluents for total body gamma and beta noble gas air dose are calculated quarterly using the methods in the ODCM with an average X/Q. The results are listed in Section II.

6.7.3 Doses Due to H-3 and Particulates with Half Lives Greater than 8 days.

The doses due to H-3 and Particulates with half-lives greater than 8 days for total body and critical organ dose are calculated quarterly using the highest of infant or child dose factors and an average X/Q. The results are listed in Section II for inhalation, ground and food.

6.7.4 Direct Radiation Dose to Individuals and Populations

Direct radiation doses attributed to the gamma radiation emitted from the containment structure were not observed above local background at any TLD sample locations for this annual period.

6.7.5 40 CFR 190 Dose Evaluation

ODCM Radiological Effluent Controls require dose evaluations and a special report to demonstrate compliance with 40 CFR Part 190 only if calculated yearly doses exceed two times the annual design objectives for liquid and/or gaseous effluents. At no time during 2020 were any of these limits exceeded; therefore, no special report was required.

The external Total Body Dose is comprised of:

- 1) Total Body Dose due to noble gas radionuclides in gaseous effluents
- 2) Dose due to radioactive waste and the ISFSI
- 3) Total Body Dose due to radioactivity deposited on the ground (this dose is accounted for in the determination of the non-noble gas dose and is not considered here)

The Total Body Dose, external is given by:

$$D_{\text{ext}} = D_{\text{tb}} + D_{\text{osf}}$$

Where D_{ext} is the external dose

D_{tb} is the total body dose

D_{osf} is the dose from on-site storage

The Total Dose is then given by:

$$D_{\text{tot}} = D_{\text{ext}} + D_{\text{liq}} + D_{\text{nng}}$$

Where D_{tot} is the total dose

D_{ext} is the external dose

D_{liq} is the dose from liquid effluents

D_{nng} is the dose from non-noble gases

Dose Limits

Total Body, annual 25 mrem

Thyroid, annual 75 mrem

Other Organs, annual 25 mrem

Calculation using REMP TLD Comparison

Indicating TLD station {OTD-S-(I)}, closest to on site storage, in mrem/week minus background, in mrem/week

	OTD-S-(I) mrem/wk	Background mrem/wk	Net mrem/wk	Weeks/qtr	Qtr Dose mrem/qtr
Quarter 1	1.6	1.3	0.3	13	3.9
Quarter 2	1.7	1.4	0.3	13	3.9
Quarter 3	1.5	1.2	0.3	13	3.9
Quarter 4	1.8	1.7	0.1	13	1.3
Dext					13.0

$$D_{\text{ext}} = 13.0 \text{ mrem}$$

Maximum offsite doses from report

$$D_{\text{tbwb}} = 1.14\text{E-}02 \text{ mrem}, D_{\text{tbco}} = 1.14\text{E-}02 \text{ mrem}$$

$$D_{\text{liqwb}} = 1.18\text{E+}00 \text{ mrem} \quad D_{\text{liqco}} = 1.86\text{E+}00 \text{ mrem}$$

$$D_{\text{tot wholebody}} = 13.0 + 1.14\text{E-}02 + 1.18\text{E+}00 = 14.19 \text{ mrem}$$

$$D_{\text{tot critical organ}} = 13.0 + 1.14\text{E-}02 + 1.86\text{E+}00 = 14.87 \text{ mrem}$$

These reported doses are bounding cases demonstrating compliance. Actual REMP TLD readings do not show any deviation from historical averages for this location, both pre and post construction of the SG storage mausoleum and ISFSI. On-site TLD's used for dose monitoring at onsite rad storage facilities do not have identical counterparts at the site boundary or actual offsite receptors. Additionally the liquid dose pathway, since it is downstream of the indicator location and is not hydro-geologically connected, would produce very conservative results compared to calculating actual dose.

6.8 Groundwater Monitoring Program and Observations

OPPD conducted groundwater sampling from 22 wells, 2 surface water sites, and 4 storm water headers within the site property per NEI 07-07. Additionally, Nebraska requirements regarding avoidance of snow runoff were deleted, so storm water sampling is now performed quarterly, if available. Wells MW-2 and MW-2B were decommissioned in the third quarter 2020 due to being within the building demolition footprint. Three wells (MW-13A & 13B and MW-14) were added to the program to replace those lost. The well development was performed in the 4th quarter of 2020; the first sampling will occur in 2021. Wells MW-12A & 12B sampling was not conducted in the first quarter of 2020 due to lowland flooding at the locations.

Additional radiological surveys were performed during decommissioning characterization; no plant related nuclides were discovered in soil. Ten sample locations in sectors experiencing significant (>10%) wind direction were established to assess potential atmospheric deposition. After an initial sampling regime in all ten sectors displayed no detectable tritium, the sampling program was switched to 2 affected sectors per rain event and an upwind background test. Two rain sampling events were conducted. No tritium activity in excess of the vendor's Minimum Detectable Activity (MDA) was reported. Storm water sampling was impacted by severe drought (rain was absorbed versus creating runoff) and/or had no rain or snow events significant enough to collect storm water or rain samples. No tritium activity in excess of the vendor's Minimum Detectable Activity (MDA) was reported in collected storm water or rain sampling.

No wells had any identified tritium > 2 sigma of the MDA value. Some Sr-90 results identified < MDA were retained during statistical data review based on historical station shallow well trends. Gamma isotopics and some hard to detect nuclides were reduced to an annual sample frequency (Ni-63, Fe-55, Sr-90 in deep wells) based on 2 years of quarterly sampling with no detections above MDA and Groundwater Protection assessment audit recommendations.

The Fort Calhoun REMP sampling did not detect tritium in samples within the Missouri River downstream at the site boundary or at the nearest municipal drinking water facility. No groundwater drinking pathway exists on site. Groundwater monitoring of neighboring drinking wells is performed to have data, if a plume were identified on site. No state or federal drinking water limits and no site groundwater protection program administrative limits were exceeded.

SECTION II
QUARTERLY DOSES FROM EFFLUENTS

Offsite Dose Calculation Manual

January 1, 2020 - December 31, 2020

Quarterly Dose Calculation Results

January 1, 2020 through December 31, 2020

With the implementation of the Fort Calhoun Station Radiological Effluent Technical Specifications (RETS) on October 1, 1985, radiation doses in the unrestricted area from liquid and gaseous effluents must be calculated on a quarterly basis in accordance with the Offsite Dose Calculation Manual (ODCM). These calculations are performed to ensure the annual dose limits delineated in Appendix I of 10 CFR 50 and implemented by RETS are not exceeded. If the results of the quarterly calculations exceed fifty percent (50%) of the annual limits of Appendix I, actions are taken to reduce effluents so that the resultant doses do not exceed the annual limits during the remainder of the year and a special report is submitted to the Nuclear Regulatory Commission. No special reports were required for 2020 calculated doses.

This section presents the results of the quarterly dose calculations performed during the period January 1, 2020 through December 31, 2020. Details are shown as to the types, sources and resultant doses from the effluents, the annual limits and a comparison to the annual limits.

FORT CALHOUN STATION
CHEMISTRY FORM

FC-421
R8

QUARTERLY CUMULATIVE DOSE CONTRIBUTION FROM RADIOACTIVE EFFLUENTS
FORT CALHOUN FIRST QUARTER 2020 DOSE PROJECTIONS

I. Liquid Effluents:	Total Body Dose (mrem)	Critical Organ Dose (mrem)
Batch:	1.15E-01	3.23E-01
Continuous:	0.00E+00	0.00E+00
Totals:	1.15E-01	3.23E-01
ODCM Quarterly Objective:	1.50E+00	5.00E+00
Percent of Quarterly Obj:	7.67 %	6.46 %
ODCM Annual Objective:	3.00E+00	1.00E+01
YTD Percent of Annual Obj:	3.83 %	3.23 %
II. Gaseous Effluents:		
	Total Body Gamma Dose (mrad)	Total Body Beta Dose (mrad)
A. Noble Gas Air Dose:	1.07E-04	1.22E-02
ODCM Quarterly Objective:	5.00E+00	1.00E+01
Percent of Quarterly Obj:	0.00 %	0.12 %
ODCM Annual Objective:	1.00E+01	2.00E+01
YTD Percent of Annual Obj:	0.00 %	0.06 %
B. I-131, I-133, Tritium, C-14, and Particulates with Half-Lives > 8 Days:	Total Body Dose (mrem)	Critical Organ Dose (mrem)
Inhalation:	6.25E-04	6.25E-04
Ground and Food:	2.89E-03	2.89E-03
Totals:	3.51E-03	3.51E-03
ODCM Quarterly Objective:	7.50E+00	7.50E+00
Percent of Quarterly Obj:	0.05 %	0.05 %
ODCM Annual Objective:	1.50E+01	1.50E+01
YTD Percent of Annual Obj:	0.02 %	0.02 %

Reviewed by: 

FORT CALHOUN STATION
CHEMISTRY FORM

FC-421
R8

QUARTERLY CUMULATIVE DOSE CONTRIBUTION FROM RADIOACTIVE EFFLUENTS
FORT CALHOUN SECOND QUARTER 2020 DOSE PROJECTIONS

I. Liquid Effluents:	Total Body Dose (mrem)	Critical Organ Dose (mrem)
-----	-----	-----
Batch:	3.12E-01	8.77E-01
Continuous:	0.00E+00	0.00E+00
-----	-----	-----
Totals:	3.12E-01	8.77E-01
ODCM Quarterly Objective:	1.50E+00	5.00E+00
-----	-----	-----
Percent of Quarterly Obj:	20.80 %	17.54 %
ODCM Annual Objective:	3.00E+00	1.00E+01
-----	-----	-----
YTD Percent of Annual Obj:	14.20 %	12.00 %

II. Gaseous Effluents:	Total Body Gamma Dose (mrad)	Total Body Beta Dose (mrad)
-----	-----	-----
A. Noble Gas Air Dose:	3.16E-05	3.58E-03
ODCM Quarterly Objective:	5.00E+00	1.00E+01
-----	-----	-----
Percent of Quarterly Obj:	0.00 %	0.04 %
ODCM Annual Objective:	1.00E+01	2.00E+01
-----	-----	-----
YTD Percent of Annual Obj:	0.00 %	0.08 %
B. I-131, I-133, Tritium, C-14, and Particulates with Half-Lives > 8 Days:	Total Body Dose (mrem)	Critical Organ Dose (mrem)
-----	-----	-----
Inhalation:	2.80E-04	2.80E-04
Ground and Food:	1.29E-03	1.30E-03
-----	-----	-----
Totals:	1.57E-03	1.58E-03
ODCM Quarterly Objective:	7.50E+00	7.50E+00
-----	-----	-----
Percent of Quarterly Obj:	0.02 %	0.02 %
ODCM Annual Objective:	1.50E+01	1.50E+01
-----	-----	-----
YTD Percent of Annual Obj:	0.03 %	0.03 %

Reviewed by: 

N

FORT CALHOUN STATION
CHEMISTRY FORMFC-421
R8QUARTERLY CUMULATIVE DOSE CONTRIBUTION FROM RADIOACTIVE EFFLUENTS
FORT CALHOUN THIRD QUARTER 2020 DOSE PROJECTIONS

I. Liquid Effluents:	Total Body Dose (mrem)	Critical Organ Dose (mrem)
Batch:	2.13E-01	6.04E-01
Continuous:	0.00E+00	0.00E+00
Totals:	2.13E-01	6.04E-01
ODCM Quarterly Objective:	1.50E+00	5.00E+00
Percent of Quarterly Obj:	14.20 %	12.08 %
ODCM Annual Objective:	3.00E+00	1.00E+01
YTD Percent of Annual Obj:	21.33 %	18.00 %
II. Gaseous Effluents:		
	Total Body Gamma Dose (mrad)	Total Body Beta Dose (mrad)
A. Noble Gas Air Dose:	0.00E+00	0.00E+00
ODCM Quarterly Objective:	5.00E+00	1.00E+01
Percent of Quarterly Obj:	0.00 %	0.00 %
ODCM Annual Objective:	1.00E+01	2.00E+01
YTD Percent of Annual Obj:	0.00 %	0.08 %
B. I-131, I-133, Tritium, C-14, and Particulates with Half-Lives > 8 Days:	Total Body Dose (mrem)	Critical Organ Dose (mrem)
Inhalation:	4.97E-04	4.97E-04
Ground and Food:	2.31E-03	2.31E-03
Totals:	2.80E-03	2.81E-03
ODCM Quarterly Objective:	7.50E+00	7.50E+00
Percent of Quarterly Obj:	0.04 %	0.04 %
ODCM Annual Objective:	1.50E+01	1.50E+01
YTD Percent of Annual Obj:	0.05 %	0.05 %

Reviewed by: 

FORT CALHOUN STATION
CHEMISTRY FORM

FC-421
R8

QUARTERLY CUMULATIVE DOSE CONTRIBUTION FROM RADIOACTIVE EFFLUENTS
FORT CALHOUN FOURTH QUARTER 2020 DOSE PROJECTIONS

I. Liquid Effluents:	Total Body Dose (mrem)	Critical Organ Dose (mrem)
-----	-----	-----
Batch:	0.00E+00	0.00E+00
Continuous:	0.00E+00	0.00E+00
-----	-----	-----
Totals:	0.00E+00	0.00E+00
ODCM Quarterly Objective:	1.50E+00	5.00E+00
-----	-----	-----
Percent of Quarterly Obj:	0.00 %	0.00 %
ODCM Annual Objective:	3.00E+00	1.00E+01
-----	-----	-----
YTD Percent of Annual Obj:	21.33 %	18.00 %
II. Gaseous Effluents:	Total Body Gamma Dose (mrad)	Total Body Beta Dose (mrad)
-----	-----	-----
A. Noble Gas Air Dose:	0.00E+00	0.00E+00
ODCM Quarterly Objective:	5.00E+00	1.00E+01
-----	-----	-----
Percent of Quarterly Obj:	0.00 %	0.00 %
ODCM Annual Objective:	1.00E+01	2.00E+01
-----	-----	-----
YTD Percent of Annual Obj:	0.00 %	0.08 %
B. I-131, I-133, Tritium, C-14, and Particulates with Half-Lives > 8 Days:	Total Body Dose (mrem)	Critical Organ Dose (mrem)
-----	-----	-----
Inhalation:	4.30E-04	4.30E-04
Ground and Food:	1.99E-03	1.99E-03
-----	-----	-----
Totals:	2.42E-03	2.42E-03
ODCM Quarterly Objective:	7.50E+00	7.50E+00
-----	-----	-----
Percent of Quarterly Obj:	0.03 %	0.03 %
ODCM Annual Objective:	1.50E+01	1.50E+01
-----	-----	-----
YTD Percent of Annual Obj:	0.07 %	0.07 %

Reviewed by: 

RADIOLOGICAL EFFLUENT RELEASES

Table III.1	Batch Liquid and Gas Release Summary
Table III.2	Abnormal Batch Liquid and Gaseous Release Summary
Table III.3	Gaseous Effluents - Summation of all Releases
Table III.4	Gaseous Effluent Releases - Batch Mode
Table III.5	Gaseous Effluent Releases - Continuous Mode
Table III.6	Liquid Effluents - Summation of all Releases
Table III.7	Liquid Effluent Releases - Batch Mode
Table III.8	Liquid Effluent Releases - Continuous Mode
Table III.9	Groundwater Tritium Results

January 1, 2020 - December 31, 2020

TABLE III.1
 BATCH LIQUID AND GASEOUS RELEASE SUMMARY
 JANUARY THROUGH DECEMBER 2020

A. Liquid Releases All Sources	1st Qtr	2nd Qtr	3rd Qtr	4th Qtr	Year
1. Number of Batch Releases:	12	29	9		50
2. Total Time Period for Batch Releases(min):	2,839	9,933	2,001		14,773
3. Maximum Time Period for Batch Releases(min):	414	4,025	849		4,025
4. Average Time Period for Batch Releases(min):	237	343	222		295
5. Minimum Time Period for Batch Releases(min):	85	105	123		85
6. Average Dilution Stream Flow During Periods of Release into the Missouri River(mls/min):	2.735E+07	2.650E+07	2.436E+07		2.632E+07
 B. Gaseous Releases All Sources	 1st Qtr	 2nd Qtr	 3rd Qtr	 4th Qtr	 Year
1. Number of Batch Releases:					
2. Total Time Period for Batch Releases(min):					
3. Maximum Time Period for Batch Releases(min):					
4. Average Time Period for Batch Releases(min):					
5. Minimum Time Period for Batch Releases(min):					

TABLE III.2
ABNORMAL BATCH LIQUID AND GASEOUS RELEASE SUMMARY
JANUARY THROUGH DECEMBER 2020

A. Liquid Releases All Sources	1st Qtr	2nd Qtr	3rd Qtr	4th Qtr	Year
Number of Releases:	0	0	0	0	0
Total Activity Releases(Ci):	0.00E+00	0.00E+00	0.00E+00	0.00E+00	0.00E+00
B. Gaseous Releases All Sources	1st Qtr	2nd Qtr	3rd Qtr	4th Qtr	Year
Number of Releases:	0	0	0	0	0
Total Activity Releases (Ci):	0.00E+00	0.00E+00	0.00E+00	0.00E+00	0.00E+00

TABLE III.3
GASEOUS EFFLUENTS--SUMMATION OF ALL RELEASES
JANUARY THROUGH DECEMBER 2020

	<u>1st Quarter</u>	<u>2nd Quarter</u>	<u>3rd Quarter</u>	<u>4th Quarter</u>	<u>Year</u>
A. Fission & Activation Gases					
Total Release (Ci):	2.84E+00	8.35E-01	0.00E+00	0.00E+00	3.68E+00
Average Release Rate (uCi/sec):	3.61E-01	1.06E-01	0.00E+00	0.00E+00	1.16E-01
Total Error (%): <u>25.00</u>					
B. Iodines					
Total Release (Ci):	0.00E+00	0.00E+00	0.00E+00	0.00E+00	0.00E+00
Average Release Rate (uCi/sec):	0.00E+00	0.00E+00	0.00E+00	0.00E+00	0.00E+00
Total Error (%): <u>21.2</u>					
C. Particulates					
Total Release (Ci):	0.00E+00	1.27E-08	9.84E-08	0.00E+00	1.11E-07
Average Release Rate (uCi/sec):	0.00E+00	1.62E-09	1.24E-08	0.00E+00	3.51E-09
Total Error (%): <u>20.62</u>					
Gross Alpha:					
Total Error (%): <u>20.62</u>	8.94E-07	1.93E-06	1.81E-06	6.55E-06	1.12E-05
D. Tritium					
Total Release (Ci):	3.92E-01	1.76E-01	3.12E-01	2.70E-01	1.15E+00
Average Release Rate (uCi/sec):	4.99E-02	2.24E-02	3.93E-02	3.40E-02	3.64E-02
Total Error (%): <u>25.08</u>					
E. Carbon-14					
Total Release (Ci):	0.00E+00	0.00E+00	0.00E+00	0.00E+00	0.00E+00
Average Release Rate (uCi/sec):	0.00E+00	0.00E+00	0.00E+00	0.00E+00	0.00E+00
Total Error (%): <u>20.62</u>					

NOTE: Values reported as zero are determined to be below the Lower Limit of Detection (LLD).

TABLE III.4
 GASEOUS EFFLUENTS--GROUND LEVEL RELEASES
 JANUARY THROUGH DECEMBER 2020
 Batch Mode

<u>Nuclides(Ci)</u>	<u>1st Quarter</u>	<u>2nd Quarter</u>	<u>3rd Quarter</u>	<u>4th Quarter</u>	<u>YEAR</u>
Fission & Activation Gases					
Totals for Period:	0.00E+00	0.00E+00	0.00E+00	0.00E+00	0.00E+00
Iodines					
Totals for Period:	0.00E+00	0.00E+00	0.00E+00	0.00E+00	0.00E+00
Particulates					
Totals for Period:	0.00E+00	0.00E+00	0.00E+00	0.00E+00	0.00E+00
Tritium and Gross Alpha					

NOTE: Values reported as zero are determined to be below the Lower Limit of Detection (LLD).

TABLE III.5
GASEOUS EFFLUENTS--GROUND LEVEL RELEASES
JANUARY THROUGH DECEMBER 2020
Continuous Mode

<u>Nuclides(Ci)</u>	<u>1st Quarter</u>	<u>2nd Quarter</u>	<u>3rd Quarter</u>	<u>4th Quarter</u>	<u>Year</u>
Fission & Activation Gases					
KR-85	2.84E+00	8.35E-01	0.00E+00	0.00E+00	3.68E+00
Totals for Period:	2.84E+00	8.35E-01	0.00E+00	0.00E+00	3.68E+00
Iodines					
Totals for Period:	0.00E+00	0.00E+00	0.00E+00	0.00E+00	0.00E+00
Particulates					
CS-137	0.00E+00	1.27E-08	9.84E-08	0.00E+00	1.11E-07
Totals for Period:	0.00E+00	1.27E-08	9.84E-08	0.00E+00	1.11E-07
Tritium and Gross Alpha					
H-3	3.92E-01	1.76E-01	3.12E-01	2.70E-01	1.15E+00
ALPHA	8.94E-07	1.93E-06	1.81E-06	6.55E-06	1.12E-05

NOTE: Values reported as zero are determined to be below the Lower Limit of Detection (LLD).

TABLE III.6
LIQUID EFFLUENTS--SUMMATION OF ALL RELEASES
JANUARY THROUGH DECEMBER 2020

	<u>1st Quarter</u>	<u>2nd Quarter</u>	<u>3rd Quarter</u>	<u>4th Quarter</u>	<u>Year</u>
A. Fission & Activation Products					
Total Release (No H-3,Gas,Alpha) (Ci):	1.21E-03	2.61E-03	1.79E-03	0.00E+00	5.61E-03
Average Diluted Concentration (uCi/mL):	1.56E-08	1.55E-08	5.66E-08	0.00E+00	2.02E-08
10 CFR 20, App. B Limit 1.00E-06(uCi/mL)					
Percent of Limit (%):	1.56E+00	1.55E+00	5.66E+00	0.00E+00	2.02E+00
Total Error (%):	<u>22.99</u>				
B. Tritium					
Total Release (Ci):	7.52E-01	2.23E+00	6.58E-01	0.00E+00	3.64E+00
Average Diluted Concentration (uCi/mL):	9.68E-06	1.32E-05	2.08E-05	0.00E+00	1.31E-05
10 CFR 20, App. B Limit <u>1.00E-03</u> (uCi/mL)					
Percent of Limit (%):	9.68E-01	1.32E+00	2.08E+00	0.00E+00	1.31E+00
Total Error (%):	<u>25.00</u>				
C. Dissolved & Entrained Gases					
Total Release (Ci):	0.00E+00	2.81E-05	0.00E+00	0.00E+00	2.81E-05
Average Diluted Concentration (uCi/mL):	0.00E+00	1.67E-10	0.00E+00	0.00E+00	1.01E-10
ODCM Limit <u>2.00E-04</u> (uCi/mL)					
Percent of Limit (%):	0.00E+00	8.33E-05	0.00E+00	0.00E+00	5.06E-05
Total Error (%):	<u>120.04</u>				
D. Gross Alpha Radioactivity					
Total Release (Ci):	0.00E+00	0.00E+00	0.00E+00	0.00E+00	0.00E+00
Total Error (%):	<u>27.22</u>				
E. Volume of Waste Released Prior to Dilution (Liters):	2.27E+05	7.60E+05	1.81E+05		1.17E+06
F. Volume of Dilution Water During Releases (Liters):	7.74E+07	1.61E+08	3.14E+07	0.00E+00	2.70E+08

NOTE: Values reported as zero are determined to be below the Lower Limit of Detection (LLD).

TABLE III.7
LIQUID EFFLUENTS
JANUARY THROUGH DECEMBER 2020
Batch Mode

<u>Nuclides(Ci)</u>	<u>1st Quarter</u>	<u>2nd Quarter</u>	<u>3rd Quarter</u>	<u>4th Quarter</u>	<u>Year</u>
Fission & Activation Gases					
SB-125	0.00E+00	2.56E-06	0.00E+00	0.00E+00	2.56E-06
NI-63	2.48E-04	0.00E+00	0.00E+00	0.00E+00	2.48E-04
CS-137	9.42E-04	2.56E-03	1.77E-03	0.00E+00	5.27E-03
CO-60	2.04E-05	4.04E-05	2.07E-05	0.00E+00	8.15E-05
CS-134	8.60E-07	9.23E-07	3.00E-06	0.00E+00	4.79E-06
EU-152	0.00E+00	2.09E-07	0.00E+00	0.00E+00	2.09E-07
Totals for Period:	1.21E-03	2.61E-03	1.79E-03	.00E+00	5.61E-03
Dissolved & Entrained Gases					
KR-85	0.00E+00	2.81E-05	0.00E+00	0.00E+00	2.81E-05
Totals for Period:	0.00E+00	2.81E-05	0.00E+00	0.00E+00	2.81E-05
Tritium and Gross Alpha					
H-3	7.52E-01	2.23E+00	6.58E-01	0.00E+00	3.64E+00

NOTE: Values reported as zero are determined to be below the Lower Limit of Detection (LLD) values.

Reported Alpha activity was attributed to natural short-lived radionuclides. This was confirmed by quarterly offside vendor analysis.

TABLE III.8
LIQUID EFFLUENTS
JANUARY THROUGH DECEMBER 2020
Continuous Mode

<u>Nuclides(Ci)</u>	<u>1st Quarter</u>	<u>2nd Quarter</u>	<u>3rd Quarter</u>	<u>4th Quarter</u>	<u>Year</u>
Fission & Activation Products					
Totals for Period:	0.00E+00	0.00E+00	0.00E+00	0.00E+00	0.00E+00
Dissolved & Entrained Gases					
Totals for Period:	0.00E+00	0.00E+00	0.00E+00	0.00E+00	0.00E+00
Tritium and Gross Alpha					
H-3	0.00E+00	0.00E+00	0.00E+00	0.00E+00	0.00E+00

NOTE: Values reported as zero are determined to be below the Lower Limit of Detection (LLD).

TABLE III.9
GROUNDWATER ANALYSIS RESULTS
pCi/L
JANUARY THROUGH DECEMBER 2020

	<u>1st Quarter</u>	<u>2nd Quarter</u>	<u>3rd Quarter</u>	<u>4th Quarter</u>
<u>MW-1A</u>				
Tritium	0.00E+00	0.00E+00	0.00E+00	0.00E+00
FE-55		0.00E+00		
NI-63		0.00E+00		
Sr-90		0.00E+00		
Total Gamma		0.00E+00		
<u>MW-1B</u>				
Tritium	0.00E+00	0.00E+00	0.00E+00	0.00E+00
FE-55		0.00E+00		
NI-63		0.00E+00		
Sr-90		0.00E+00		
Total Gamma		0.00E+00		
<u>MW-2</u>				
Tritium	0.00E+00	0.00E+00	0.00E+00	0.00E+00
FE-55		0.00E+00		
NI-63		0.00E+00		
Sr-90		0.00E+00		
Total Gamma		0.00E+00		
<u>MW-2A</u>				
Tritium	0.00E+00	0.00E+00		
FE-55		0.00E+00		
NI-63		0.00E+00		
Sr-90		0.00E+00		
Total Gamma		0.00E+00		
<u>MW-2B</u>				
Tritium	0.00E+00	0.00E+00		
FE-55		0.00E+00		
NI-63		0.00E+00		
Sr-90		0.00E+00		
Total Gamma		0.00E+00		
<u>MW-3</u>				
Tritium	0.00E+00	0.00E+00	0.00E+00	0.00E+00
FE-55		0.00E+00		
NI-63		0.00E+00		
Sr-90		0.00E+00		
Total Gamma				
<u>MW-3A</u>				
Tritium	0.00E+00	0.00E+00	0.00E+00	0.00E+00
FE-55	0.00E+00	0.00E+00	0.00E+00	0.00E+00
NI-63	0.00E+00	0.00E+00	0.00E+00	0.00E+00
Sr-90	0.00E+00	5.76E-01	0.00E+00	0.00E+00
Total Gamma		0.00E+00		0.00E+00
<u>MW-3B</u>				
Tritium	0.00E+00	0.00E+00	0.00E+00	0.00E+00
FE-55	0.00E+00	0.00E+00	0.00E+00	0.00E+00
NI-63	0.00E+00	0.00E+00	0.00E+00	0.00E+00
Sr-90	0.00E+00	0.00E+00	0.00E+00	0.00E+00
Total Gamma				0.00E+00
<u>MW-4B</u>				
Tritium	0.00E+00	0.00E+00	0.00E+00	0.00E+00
FE-55		0.00E+00		
NI-63		0.00E+00		
Sr-90		0.00E+00		
Total Gamma		0.00E+00		

TABLE III.9
GROUNDWATER ANALYSIS RESULTS
pCi/L
JANUARY THROUGH DECEMBER 2020

	<u>1st Quarter</u>	<u>2nd Quarter</u>	<u>3rd Quarter</u>	<u>4th Quarter</u>
<u>MW-5A</u>				
Tritium	0.00E+00	0.00E+00	0.00E+00	0.00E+00
FE-55		0.00E+00		
NI-63		0.00E+00		
Sr-90		8.28E-01		
Total Gamma		0.00E+00		
<u>MW-5B</u>				
Tritium	0.00E+00	0.00E+00	0.00E+00	0.00E+00
FE-55		0.00E+00		
NI-63		0.00E+00		
Sr-90		0.00E+00		
Total Gamma		0.00E+00		
<u>MW-6</u>				
Tritium	0.00E+00	0.00E+00	0.00E+00	0.00E+00
FE-55	0.00E+00	0.00E+00	0.00E+00	0.00E+00
NI-63	0.00E+00	0.00E+00	0.00E+00	0.00E+00
Sr-90	4.84E-01	8.40E-01	8.64E-01	0.00E+00
Total Gamma	0.00E+00	0.00E+00	0.00E+00	0.00E+00
<u>MW-7</u>				
Tritium	0.00E+00	0.00E+00	0.00E+00	0.00E+00
FE-55		0.00E+00		
NI-63		0.00E+00		
Sr-90		7.38E-01		
Total Gamma		0.00E+00		
<u>MW-12A</u>				
Tritium		0.00E+00	0.00E+00	0.00E+00
FE-55		0.00E+00		
NI-63		0.00E+00		
Sr-90		0.00E+00		
Total Gamma		0.00E+00		
<u>MW-12B</u>				
Tritium		0.00E+00	0.00E+00	0.00E+00
FE-55		0.00E+00		
NI-63		0.00E+00		
Sr-90		0.00E+00		
Total Gamma		0.00E+00		
<u>EAST LAGOON</u>				
Tritium	0.00E+00	0.00E+00	0.00E+00	0.00E+00
FE-55				
NI-63				
Sr-90				
Total Gamma	0.00E+00	0.00E+00	0.00E+00	0.00E+00
<u>WEST LAGOON</u>				
Tritium	0.00E+00	0.00E+00	0.00E+00	0.00E+00
FE-55				
NI-63				
Sr-90				
Total Gamma	0.00E+00	0.00E+00	0.00E+00	0.00E+00
<u>NORTH STORMWATER HDR</u>				
Tritium		0.00E+00		
FE-55				
NI-63				
Sr-90				
Total Gamma				

TABLE III.9
GROUNDWATER ANALYSIS RESULTS
pCi/L
JANUARY THROUGH DECEMBER 2020

	<u>1st Quarter</u>	<u>2nd Quarter</u>	<u>3rd Quarter</u>	<u>4th Quarter</u>
<u>SOUTH STORMWATER HDR</u>				
Tritium		0.00E+00		
FE-55				
NI-63				
Sr-90				
Total Gamma				
<u>MW-13B</u>				
Tritium				
FE-55				
NI-63				
Sr-90				
Total Gamma				
<u>SW-6 ISFSI</u>				
Tritium		0.00E+00		
FE-55				
NI-63				
Sr-90				
Total Gamma				
<u>SW-8 NORTH PA</u>				
Tritium		0.00E+00		
FE-55				
NI-63				
Sr-90				
Total Gamma				
<u>MW-14</u>				
Tritium				
FE-55				
NI-63				
Sr-90				
Total Gamma				
<u>MW-13A</u>				
Tritium				
FE-55				
NI-63				
Sr-90				
Total Gamma				

NOTE: Values reported as zero are determined to be below the Lower Limit of Detection (LLD). Only Tritium and Gamma are required for each sampling event. Hard to detect (HTD) nuclide sampling frequency is per station procedures. Missed sampling events are covered in the executive summary.

SECTION IV
DOSE FROM GASEOUS EFFLUENTS

GASPAR II OUTPUT

January 1, 2020 - December 31, 2020

Radioactive Effluent Releases - First, Second, Third and Fourth Quarters 2020

GASEOUS EFFLUENTS

Radioactive gaseous releases for the reporting period totaled $3.68\text{E}+00$ curies of inert gas. The gross gaseous activity release rates were $3.61\text{E}-01$ $\mu\text{Ci}/\text{sec}$ for the first quarter, $1.06\text{E}-01$ $\mu\text{Ci}/\text{sec}$ for the second quarter, $0.00\text{E}+00$ $\mu\text{Ci}/\text{sec}$ for the third quarter, and $0.00\text{E}+00$ $\mu\text{Ci}/\text{sec}$ for the fourth quarter.

No radioactive halogens releases were released during the reporting period from gaseous effluent discharges.

Radioactive particulate releases for the reporting period totaled $1.11\text{E}-07$ curies. The particulate release rates were $0.00\text{E}+00$ $\mu\text{Ci}/\text{sec}$ for the first quarter, $1.62\text{E}-09$ $\mu\text{Ci}/\text{sec}$ for the second quarter, $1.24\text{E}-08$ $\mu\text{Ci}/\text{sec}$ for the third quarter, and $0.00\text{E}+00$ $\mu\text{Ci}/\text{sec}$ for the fourth quarter.

Radioactive tritium released during the reporting period totaled $1.15\text{E}+00$ curies.

Off-site vendor analysis of weekly composite samples indicated that no gross alpha radioactivity was released during the reporting period.

POTENTIAL DOSES TO INDIVIDUALS AND POPULATIONS

A. Potential Annual Doses to Individuals from Gaseous Releases

Total body, skin, and organ doses from ground releases were calculated in mRem to an average adult, teenager, child, and infant using the annual configuration of the GASPARD II program. Results to each receptor are shown in Tables IV-A-1 through IV-A-36. Also, the doses to the same groups, Table IV-B-1, in units of mRad, due to gamma and beta radiation carried by air, was computed using GASPARD II. In its annual configuration, GASPARD II assumes that all release rates are entered in curies per year (Ci/yr).

The inputs to GASPARD II for the annual period from January 1, 2020 through December 31, 2020 were as follows:

- (1) All gaseous effluents
- (2) Entrained gases (Ar-41, Xe-131M, Xe-133M, Xe-133, Xe-135M, Xe-135, Kr-85M, Kr-87, and Kr-88) from liquid effluents.
- (3) Annual X/Q at the actual receptor locations, which are corrected for open terrain and plume depletion, are calculated according to Regulatory Guide 1.111. Also included are annual deposition rates corrected for the open terrain factor.
- (4) The production, intake and grazing fractions were as follows: 1.0 for leafy vegetables grown in garden of interest, 0.76 for produce grown in garden of interest, 0.5 for the pasture grazing season of the milk animal, 1.0 for pasture grazing season of the meat animal, and 8 g/m³ for the air water (humidity) concentrations.
- (5) All dose factors, transport times from receptor to individual, and usage factors are defined by Regulatory Guide 1.109 and NUREG-0172.
- (6) Site specific information, within a five-mile radius of the plant, on types of receptors located in each sector was used. That is, if a cow was not present in a sector, then the milk pathway for that sector was not considered. If it was present, then the actual sector distance was used.

These inputs introduce a most conservative approach for the following reasons:

- (1) The open terrain and deposition corrections increase annual X/Q by a factor ranging between 1.0 and 4.0

- (2) The production, intake, and grazing fractions, as defined in the input definition statement, represent the environment in an extremely conservative manner.

B. Potential Semiannual Doses to Population from Gaseous Releases

The GASPAR II program in its annual configuration was also used to calculate the ALARA integrated population dose summary for the total body, skin, and organ doses in man-rem for all individuals within a 50-mile radius. The population-integrated dose is the summation of the dose received by all individuals and has units of man-thyroid-rem when applied to the summation of thyroid doses. The same inputs were used as in the individual case with the addition of the following:

- (1) A total population of 950,006 (based on the 2010 census) was used to define the sector segments within a 50-mile radius of the plant.
- (2) Production of milk, meat, and vegetation is based on 1973 annual data for Nebraska as recommended by the Nuclear Regulatory Commission for use in GASPAR II.

TABLE IV-A- 1

FORT CALHOUN ANNUAL 2020, DOSE PROJECTIONS
 SPECIAL LOCATION NO. 1 RES
 AT 4.36 MILES N

ANNUAL_BETA_AIR_DOSE = 2.96E-05 MILLRADS
 ANNUAL_GAMMA_AIR_DOSE = 2.61E-07 MILLRADS

PATHWAY	T.BODY	GI-TRACT	BONE	LIVER	KIDNEY	THYROID	LUNG	SKIN
PLUME	: 1.71E-07	: 1.71E-07	: 1.71E-07	: 1.71E-07	: 1.71E-07	: 1.71E-07	: 4.54E-07	: 2.05E-05
GROUND	: 2.06E-08	: 2.06E-08	: 2.06E-08	: 2.06E-08	: 2.06E-08	: 2.06E-08	: 2.06E-08	: 2.41E-08
INHAL	:	:	:	:	:	:	:	:
ADULT	: 3.41E-06	: 3.41E-06	: 1.69E-10	: 3.41E-06	: 3.41E-06	: 3.41E-06	: 3.41E-06	: 3.41E-06
TEEN	: 3.44E-06	: 3.44E-06	: 2.37E-10	: 3.44E-06	: 3.44E-06	: 3.44E-06	: 3.44E-06	: 3.44E-06
CHILD	: 3.04E-06	: 3.04E-06	: 3.21E-10	: 3.04E-06	: 3.04E-06	: 3.04E-06	: 3.04E-06	: 3.04E-06
INFANT	: 1.75E-06	: 1.75E-06	: 1.94E-10	: 1.75E-06	: 1.75E-06	: 1.75E-06	: 1.75E-06	: 1.75E-06

TABLE IV-A- 2

FORT CALHOUN ANNUAL 2020, DOSE PROJECTIONS
 SPECIAL LOCATION NO. 2 RES
 AT 1.93 MILES NNE

ANNUAL_BETA_AIR_DOSE = 1.59E-04 MILLRADS
 ANNUAL_GAMMA_AIR_DOSE = 1.40E-06 MILLRADS

PATHWAY	T.BODY	GI-TRACT	BONE	LIVER	KIDNEY	THYROID	LUNG	SKIN
PLUME	: 9.20E-07	: 9.20E-07	: 9.20E-07	: 9.20E-07	: 9.20E-07	: 9.20E-07	: 2.45E-06	: 1.11E-04
GROUND	: 8.71E-08	: 8.71E-08	: 8.71E-08	: 8.71E-08	: 8.71E-08	: 8.71E-08	: 8.71E-08	: 1.02E-07
INHAL	:	:	:	:	:	:	:	:
ADULT	: 1.83E-05	: 1.83E-05	: 9.67E-10	: 1.83E-05	: 1.83E-05	: 1.83E-05	: 1.83E-05	: 1.83E-05
TEEN	: 1.85E-05	: 1.85E-05	: 1.35E-09	: 1.85E-05	: 1.85E-05	: 1.85E-05	: 1.85E-05	: 1.85E-05
CHILD	: 1.63E-05	: 1.63E-05	: 1.83E-09	: 1.64E-05	: 1.63E-05	: 1.63E-05	: 1.63E-05	: 1.63E-05
INFANT	: 9.40E-06	: 9.40E-06	: 1.11E-09	: 9.41E-06	: 9.40E-06	: 9.40E-06	: 9.40E-06	: 9.40E-06

TABLE IV-A- 3

FORT CALHOUN ANNUAL 2020, DOSE PROJECTIONS
 SPECIAL LOCATION NO. 3 RES
 AT 1.52 MILES NE

ANNUAL_BETA_AIR_DOSE = 2.27E-04 MILLRADS
 ANNUAL_GAMMA_AIR_DOSE = 2.01E-06 MILLRADS

PATHWAY	T.BODY	GI-TRACT	BONE	LIVER	KIDNEY	THYROID	LUNG	SKIN
PLUME	: 1.31E-06	: 1.31E-06	: 1.31E-06	: 1.31E-06	: 1.31E-06	: 1.31E-06	: 3.50E-06	: 1.58E-04
GROUND	: 1.01E-07	: 1.01E-07	: 1.01E-07	: 1.01E-07	: 1.01E-07	: 1.01E-07	: 1.01E-07	: 1.18E-07
INHAL	:	:	:	:	:	:	:	:
ADULT	: 2.62E-05	: 2.62E-05	: 1.46E-09	: 2.62E-05	: 2.62E-05	: 2.62E-05	: 2.62E-05	: 2.62E-05
TEEN	: 2.64E-05	: 2.64E-05	: 2.05E-09	: 2.64E-05	: 2.64E-05	: 2.64E-05	: 2.64E-05	: 2.64E-05
CHILD	: 2.34E-05	: 2.34E-05	: 2.77E-09	: 2.34E-05	: 2.34E-05	: 2.34E-05	: 2.34E-05	: 2.34E-05
INFANT	: 1.34E-05	: 1.34E-05	: 1.68E-09	: 1.34E-05	: 1.34E-05	: 1.34E-05	: 1.34E-05	: 1.34E-05

TABLE IV-A- 4

FORT CALHOUN ANNUAL 2020, DOSE PROJECTIONS
 SPECIAL LOCATION NO. 4 RES
 AT 4.79 MILES ENE

ANNUAL_BETA_AIR_DOSE = 2.00E-05 MILLRADS
 ANNUAL_GAMMA_AIR_DOSE = 1.77E-07 MILLRADS

PATHWAY	T.BODY	GI-TRACT	BONE	LIVER	KIDNEY	THYROID	LUNG	SKIN
PLUME	: 1.16E-07	: 1.16E-07	: 1.16E-07	: 1.16E-07	: 1.16E-07	: 1.16E-07	: 3.08E-07	: 1.39E-05
GROUND	: 4.45E-09	: 4.45E-09	: 4.45E-09	: 4.45E-09	: 4.45E-09	: 4.45E-09	: 4.45E-09	: 5.19E-09
INHAL	:	:	:	:	:	:	:	:
ADULT	: 2.31E-06	: 2.31E-06	: 1.10E-10	: 2.31E-06	: 2.31E-06	: 2.31E-06	: 2.31E-06	: 2.31E-06
TEEN	: 2.33E-06	: 2.33E-06	: 1.54E-10	: 2.33E-06	: 2.33E-06	: 2.33E-06	: 2.33E-06	: 2.33E-06
CHILD	: 2.06E-06	: 2.06E-06	: 2.08E-10	: 2.06E-06	: 2.06E-06	: 2.06E-06	: 2.06E-06	: 2.06E-06
INFANT	: 1.18E-06	: 1.18E-06	: 1.26E-10	: 1.18E-06	: 1.18E-06	: 1.18E-06	: 1.18E-06	: 1.18E-06

TABLE IV-A- 5

FORT CALHOUN ANNUAL 2020, DOSE PROJECTIONS
 SPECIAL LOCATION NO. 5 RES
 AT 4.67 MILES E

ANNUAL_BETA_AIR_DOSE = 2.50E-05 MILLRADS
 ANNUAL_GAMMA_AIR_DOSE = 2.21E-07 MILLRADS

PATHWAY	T.BODY	GI-TRACT	BONE	LIVER	KIDNEY	THYROID	LUNG	SKIN
PLUME	: 1.45E-07	: 1.45E-07	: 1.45E-07	: 1.45E-07	: 1.45E-07	: 1.45E-07	: 3.85E-07	: 1.74E-05
GROUND	: 7.33E-09	: 7.33E-09	: 7.33E-09	: 7.33E-09	: 7.33E-09	: 7.33E-09	: 7.33E-09	: 8.56E-09
INHAL	:	:	:	:	:	:	:	:
ADULT	: 2.88E-06	: 2.88E-06	: 1.37E-10	: 2.88E-06	: 2.88E-06	: 2.88E-06	: 2.88E-06	: 2.88E-06
TEEN	: 2.91E-06	: 2.91E-06	: 1.92E-10	: 2.91E-06	: 2.91E-06	: 2.91E-06	: 2.91E-06	: 2.91E-06
CHILD	: 2.57E-06	: 2.57E-06	: 2.60E-10	: 2.57E-06	: 2.57E-06	: 2.57E-06	: 2.57E-06	: 2.57E-06
INFANT	: 1.48E-06	: 1.48E-06	: 1.57E-10	: 1.48E-06	: 1.48E-06	: 1.48E-06	: 1.48E-06	: 1.48E-06

TABLE IV-A- 6

FORT CALHOUN ANNUAL 2020, DOSE PROJECTIONS
 SPECIAL LOCATION NO. 6 RES
 AT 4.22 MILES ESE

ANNUAL_BETA_AIR_DOSE = 4.55E-05 MILLRADS
 ANNUAL_GAMMA_AIR_DOSE = 4.01E-07 MILLRADS

PATHWAY	T.BODY	GI-TRACT	BONE	LIVER	KIDNEY	THYROID	LUNG	SKIN
PLUME	: 2.63E-07	: 2.63E-07	: 2.63E-07	: 2.63E-07	: 2.63E-07	: 2.63E-07	: 6.99E-07	: 3.16E-05
GROUND	: 1.24E-08	: 1.24E-08	: 1.24E-08	: 1.24E-08	: 1.24E-08	: 1.24E-08	: 1.24E-08	: 1.44E-08
INHAL	:	:	:	:	:	:	:	:
ADULT	: 5.24E-06	: 5.24E-06	: 2.56E-10	: 5.24E-06	: 5.24E-06	: 5.24E-06	: 5.24E-06	: 5.24E-06
TEEN	: 5.29E-06	: 5.29E-06	: 3.58E-10	: 5.29E-06	: 5.29E-06	: 5.29E-06	: 5.29E-06	: 5.29E-06
CHILD	: 4.67E-06	: 4.67E-06	: 4.84E-10	: 4.67E-06	: 4.67E-06	: 4.67E-06	: 4.67E-06	: 4.67E-06
INFANT	: 2.69E-06	: 2.69E-06	: 2.93E-10	: 2.69E-06	: 2.69E-06	: 2.69E-06	: 2.69E-06	: 2.69E-06

TABLE IV-A- 7

FORT CALHOUN ANNUAL 2020, DOSE PROJECTIONS
 SPECIAL LOCATION NO. 7 RES
 AT 1.67 MILES SE

ANNUAL_BETA_AIR_DOSE = 3.41E-04 MILLRADS
 ANNUAL_GAMMA_AIR_DOSE = 3.01E-06 MILLRADS

PATHWAY	T.BODY	GI-TRACT	BONE	LIVER	KIDNEY	THYROID	LUNG	SKIN
PLUME	: 1.97E-06	: 1.97E-06	: 1.97E-06	: 1.97E-06	: 1.97E-06	: 1.97E-06	: 5.24E-06	: 2.37E-04
GROUND	: 1.93E-07	: 1.93E-07	: 1.93E-07	: 1.93E-07	: 1.93E-07	: 1.93E-07	: 1.93E-07	: 2.25E-07
INHAL	:	:	:	:	:	:	:	:
ADULT	: 3.93E-05	: 3.93E-05	: 2.10E-09	: 3.93E-05	: 3.93E-05	: 3.93E-05	: 3.93E-05	: 3.93E-05
TEEN	: 3.97E-05	: 3.97E-05	: 2.95E-09	: 3.97E-05	: 3.97E-05	: 3.97E-05	: 3.97E-05	: 3.97E-05
CHILD	: 3.50E-05	: 3.50E-05	: 3.99E-09	: 3.50E-05	: 3.50E-05	: 3.50E-05	: 3.50E-05	: 3.50E-05
INFANT	: 2.02E-05	: 2.02E-05	: 2.41E-09	: 2.02E-05	: 2.02E-05	: 2.02E-05	: 2.02E-05	: 2.02E-05

TABLE IV-A- 8

FORT CALHOUN ANNUAL 2020, DOSE PROJECTIONS
 SPECIAL LOCATION NO. 8 RES
 AT 0.65 MILES SSE

ANNUAL_BETA_AIR_DOSE = 1.52E-03 MILLRADS
 ANNUAL_GAMMA_AIR_DOSE = 1.34E-05 MILLRADS

PATHWAY	T.BODY	GI-TRACT	BONE	LIVER	KIDNEY	THYROID	LUNG	SKIN
PLUME	: 8.81E-06	: 8.81E-06	: 8.81E-06	: 8.81E-06	: 8.81E-06	: 8.81E-06	: 2.34E-05	: 1.06E-03
GROUND	: 2.75E-06	: 2.75E-06	: 2.75E-06	: 2.75E-06	: 2.75E-06	: 2.75E-06	: 2.75E-06	: 3.21E-06
INHAL	:	:	:	:	:	:	:	:
ADULT	: 1.76E-04	: 1.76E-04	: 1.01E-08	: 1.76E-04	: 1.76E-04	: 1.76E-04	: 1.76E-04	: 1.76E-04
TEEN	: 1.77E-04	: 1.77E-04	: 1.42E-08	: 1.77E-04	: 1.77E-04	: 1.77E-04	: 1.77E-04	: 1.77E-04
CHILD	: 1.56E-04	: 1.56E-04	: 1.91E-08	: 1.56E-04	: 1.56E-04	: 1.56E-04	: 1.56E-04	: 1.56E-04
INFANT	: 9.00E-05	: 9.00E-05	: 1.16E-08	: 9.00E-05	: 9.00E-05	: 9.00E-05	: 9.00E-05	: 9.00E-05

TABLE IV-A- 9

FORT CALHOUN ANNUAL 2020, DOSE PROJECTIONS
 SPECIAL LOCATION NO. 9 RES
 AT 0.73 MILES S

ANNUAL_BETA_AIR_DOSE = 9.55E-04 MILLRADS
 ANNUAL_GAMMA_AIR_DOSE = 8.43E-06 MILLRADS

PATHWAY	T.BODY	GI-TRACT	BONE	LIVER	KIDNEY	THYROID	LUNG	SKIN
PLUME	: 5.52E-06	: 5.52E-06	: 5.52E-06	: 5.52E-06	: 5.52E-06	: 5.52E-06	: 1.47E-05	: 6.63E-04
GROUND	: 1.24E-06	: 1.24E-06	: 1.24E-06	: 1.24E-06	: 1.24E-06	: 1.24E-06	: 1.24E-06	: 1.44E-06
INHAL	:	:	:	:	:	:	:	:
ADULT	: 1.10E-04	: 1.10E-04	: 6.40E-09	: 1.10E-04	: 1.10E-04	: 1.10E-04	: 1.10E-04	: 1.10E-04
TEEN	: 1.11E-04	: 1.11E-04	: 8.96E-09	: 1.11E-04	: 1.11E-04	: 1.11E-04	: 1.11E-04	: 1.11E-04
CHILD	: 9.81E-05	: 9.81E-05	: 1.21E-08	: 9.81E-05	: 9.81E-05	: 9.81E-05	: 9.81E-05	: 9.81E-05
INFANT	: 5.64E-05	: 5.64E-05	: 7.34E-09	: 5.64E-05	: 5.64E-05	: 5.64E-05	: 5.64E-05	: 5.64E-05

TABLE IV-A-10

FORT CALHOUN ANNUAL 2020, DOSE PROJECTIONS
 SPECIAL LOCATION NO. 10 RES
 AT 0.65 MILES SSW

ANNUAL_BETA_AIR_DOSE = 9.78E-04 MILLRADS
 ANNUAL_GAMMA_AIR_DOSE = 8.63E-06 MILLRADS

PATHWAY	T.BODY	GI-TRACT	BONE	LIVER	KIDNEY	THYROID	LUNG	SKIN
PLUME	: 5.65E-06	: 5.65E-06	: 5.65E-06	: 5.65E-06	: 5.65E-06	: 5.65E-06	: 1.50E-05	: 6.79E-04
GROUND	: 6.42E-07	: 6.42E-07	: 6.42E-07	: 6.42E-07	: 6.42E-07	: 6.42E-07	: 6.42E-07	: 7.49E-07
INHAL	:	:	:	:	:	:	:	:
ADULT	: 1.13E-04	: 1.13E-04	: 6.61E-09	: 1.13E-04	: 1.13E-04	: 1.13E-04	: 1.13E-04	: 1.13E-04
TEEN	: 1.14E-04	: 1.14E-04	: 9.26E-09	: 1.14E-04	: 1.14E-04	: 1.14E-04	: 1.14E-04	: 1.14E-04
CHILD	: 1.00E-04	: 1.00E-04	: 1.25E-08	: 1.00E-04	: 1.00E-04	: 1.00E-04	: 1.00E-04	: 1.00E-04
INFANT	: 5.78E-05	: 5.78E-05	: 7.58E-09	: 5.78E-05	: 5.78E-05	: 5.78E-05	: 5.78E-05	: 5.78E-05

TABLE IV-A-11

FORT CALHOUN ANNUAL 2020, DOSE PROJECTIONS
 SPECIAL LOCATION NO. 11 RES
 AT 0.73 MILES SW

ANNUAL_BETA_AIR_DOSE = 7.28E-04 MILLRADS
 ANNUAL_GAMMA_AIR_DOSE = 6.42E-06 MILLRADS

PATHWAY	T.BODY	GI-TRACT	BONE	LIVER	KIDNEY	THYROID	LUNG	SKIN
PLUME	: 4.21E-06	: 4.21E-06	: 4.21E-06	: 4.21E-06	: 4.21E-06	: 4.21E-06	: 1.12E-05	: 5.05E-04
GROUND	: 3.90E-07	: 3.90E-07	: 3.90E-07	: 3.90E-07	: 3.90E-07	: 3.90E-07	: 3.90E-07	: 4.55E-07
INHAL	:	:	:	:	:	:	:	:
ADULT	: 8.39E-05	: 8.39E-05	: 4.93E-09	: 8.39E-05	: 8.39E-05	: 8.39E-05	: 8.39E-05	: 8.39E-05
TEEN	: 8.46E-05	: 8.46E-05	: 6.90E-09	: 8.46E-05	: 8.46E-05	: 8.46E-05	: 8.46E-05	: 8.46E-05
CHILD	: 7.47E-05	: 7.47E-05	: 9.33E-09	: 7.47E-05	: 7.47E-05	: 7.47E-05	: 7.47E-05	: 7.47E-05
INFANT	: 4.30E-05	: 4.30E-05	: 5.65E-09	: 4.30E-05	: 4.30E-05	: 4.30E-05	: 4.30E-05	: 4.30E-05

TABLE IV-A-12

FORT CALHOUN ANNUAL 2020, DOSE PROJECTIONS
 SPECIAL LOCATION NO. 12 RES
 AT 1.06 MILES WSW

ANNUAL_BETA_AIR_DOSE = 3.64E-04 MILLRADS
 ANNUAL_GAMMA_AIR_DOSE = 3.21E-06 MILLRADS

PATHWAY	T.BODY	GI-TRACT	BONE	LIVER	KIDNEY	THYROID	LUNG	SKIN
PLUME	: 2.10E-06	: 2.10E-06	: 2.10E-06	: 2.10E-06	: 2.10E-06	: 2.10E-06	: 5.59E-06	: 2.53E-04
GROUND	: 1.93E-07	: 1.93E-07	: 1.93E-07	: 1.93E-07	: 1.93E-07	: 1.93E-07	: 1.93E-07	: 2.25E-07
INHAL	:	:	:	:	:	:	:	:
ADULT	: 4.19E-05	: 4.19E-05	: 2.23E-09	: 4.19E-05	: 4.19E-05	: 4.19E-05	: 4.19E-05	: 4.19E-05
TEEN	: 4.23E-05	: 4.23E-05	: 3.12E-09	: 4.23E-05	: 4.23E-05	: 4.23E-05	: 4.23E-05	: 4.23E-05
CHILD	: 3.74E-05	: 3.74E-05	: 4.22E-09	: 3.74E-05	: 3.74E-05	: 3.74E-05	: 3.74E-05	: 3.74E-05
INFANT	: 2.15E-05	: 2.15E-05	: 2.56E-09	: 2.15E-05	: 2.15E-05	: 2.15E-05	: 2.15E-05	: 2.15E-05

TABLE IV-A-13

FORT CALHOUN ANNUAL 2020, DOSE PROJECTIONS
 SPECIAL LOCATION NO. 13 RES
 AT 1.20 MILES W

ANNUAL_BETA_AIR_DOSE = 3.41E-04 MILLRADS
 ANNUAL_GAMMA_AIR_DOSE = 3.01E-06 MILLRADS

PATHWAY	T.BODY	GI-TRACT	BONE	LIVER	KIDNEY	THYROID	LUNG	SKIN
PLUME	: 1.97E-06	: 1.97E-06	: 1.97E-06	: 1.97E-06	: 1.97E-06	: 1.97E-06	: 5.24E-06	: 2.37E-04
GROUND	: 1.88E-07	: 1.88E-07	: 1.88E-07	: 1.88E-07	: 1.88E-07	: 1.88E-07	: 1.88E-07	: 2.19E-07
INHAL	:	:	:	:	:	:	:	:
ADULT	: 3.93E-05	: 3.93E-05	: 2.23E-09	: 3.93E-05	: 3.93E-05	: 3.93E-05	: 3.93E-05	: 3.93E-05
TEEN	: 3.97E-05	: 3.97E-05	: 3.13E-09	: 3.97E-05	: 3.97E-05	: 3.97E-05	: 3.97E-05	: 3.97E-05
CHILD	: 3.50E-05	: 3.50E-05	: 4.23E-09	: 3.50E-05	: 3.50E-05	: 3.50E-05	: 3.50E-05	: 3.50E-05
INFANT	: 2.02E-05	: 2.02E-05	: 2.56E-09	: 2.02E-05	: 2.02E-05	: 2.02E-05	: 2.02E-05	: 2.02E-05

TABLE IV-A-14

FORT CALHOUN ANNUAL 2020, DOSE PROJECTIONS
 SPECIAL LOCATION NO. 14 RES
 AT 2.60 MILES WNW

ANNUAL_BETA_AIR_DOSE = 7.73E-05 MILLRADS
 ANNUAL_GAMMA_AIR_DOSE = 6.82E-07 MILLRADS

PATHWAY	T.BODY	GI-TRACT	BONE	LIVER	KIDNEY	THYROID	LUNG	SKIN
PLUME	: 4.47E-07	: 4.47E-07	: 4.47E-07	: 4.47E-07	: 4.47E-07	: 4.47E-07	: 1.19E-06	: 5.37E-05
GROUND	: 3.58E-08	: 3.58E-08	: 3.58E-08	: 3.58E-08	: 3.58E-08	: 3.58E-08	: 3.58E-08	: 4.17E-08
INHAL	:	:	:	:	:	:	:	:
ADULT	: 8.91E-06	: 8.91E-06	: 4.62E-10	: 8.91E-06	: 8.91E-06	: 8.91E-06	: 8.91E-06	: 8.91E-06
TEEN	: 8.99E-06	: 8.99E-06	: 6.48E-10	: 8.99E-06	: 8.99E-06	: 8.99E-06	: 8.99E-06	: 8.99E-06
CHILD	: 7.94E-06	: 7.94E-06	: 8.76E-10	: 7.94E-06	: 7.94E-06	: 7.94E-06	: 7.94E-06	: 7.94E-06
INFANT	: 4.57E-06	: 4.57E-06	: 5.30E-10	: 4.57E-06	: 4.57E-06	: 4.57E-06	: 4.57E-06	: 4.57E-06

TABLE IV-A-15

FORT CALHOUN ANNUAL 2020, DOSE PROJECTIONS
 SPECIAL LOCATION NO. 15 RES
 AT 2.40 MILES NW

ANNUAL_BETA_AIR_DOSE = 1.18E-04 MILLRADS
 ANNUAL_GAMMA_AIR_DOSE = 1.04E-06 MILLRADS

PATHWAY	T.BODY	GI-TRACT	BONE	LIVER	KIDNEY	THYROID	LUNG	SKIN
PLUME	: 6.84E-07	: 6.84E-07	: 6.84E-07	: 6.84E-07	: 6.84E-07	: 6.84E-07	: 1.82E-06	: 8.21E-05
GROUND	: 8.71E-08	: 8.71E-08	: 8.71E-08	: 8.71E-08	: 8.71E-08	: 8.71E-08	: 8.71E-08	: 1.02E-07
INHAL	:	:	:	:	:	:	:	:
ADULT	: 1.36E-05	: 1.36E-05	: 7.19E-10	: 1.36E-05	: 1.36E-05	: 1.36E-05	: 1.36E-05	: 1.36E-05
TEEN	: 1.38E-05	: 1.38E-05	: 1.01E-09	: 1.38E-05	: 1.38E-05	: 1.38E-05	: 1.38E-05	: 1.38E-05
CHILD	: 1.21E-05	: 1.21E-05	: 1.36E-09	: 1.21E-05	: 1.21E-05	: 1.21E-05	: 1.21E-05	: 1.21E-05
INFANT	: 6.99E-06	: 6.99E-06	: 8.25E-10	: 6.99E-06	: 6.99E-06	: 6.99E-06	: 6.99E-06	: 6.99E-06

TABLE IV-A-16

FORT CALHOUN ANNUAL 2020, DOSE PROJECTIONS
 SPECIAL LOCATION NO. 16 RES
 AT 2.08 MILES NNW

ANNUAL_BETA_AIR_DOSE = 1.87E-04 MILLRADS
 ANNUAL_GAMMA_AIR_DOSE = 1.65E-06 MILLRADS

PATHWAY	T.BODY	GI-TRACT	BONE	LIVER	KIDNEY	THYROID	LUNG	SKIN
PLUME	: 1.08E-06	: 1.08E-06	: 1.08E-06	: 1.08E-06	: 1.08E-06	: 1.08E-06	: 2.87E-06	: 1.29E-04
GROUND	: 1.56E-07	: 1.56E-07	: 1.56E-07	: 1.56E-07	: 1.56E-07	: 1.56E-07	: 1.56E-07	: 1.82E-07
INHAL	:	:	:	:	:	:	:	:
ADULT	: 2.15E-05	: 2.15E-05	: 1.15E-09	: 2.15E-05	: 2.15E-05	: 2.15E-05	: 2.15E-05	: 2.15E-05
TEEN	: 2.17E-05	: 2.17E-05	: 1.61E-09	: 2.17E-05	: 2.17E-05	: 2.17E-05	: 2.17E-05	: 2.17E-05
CHILD	: 1.92E-05	: 1.92E-05	: 2.18E-09	: 1.92E-05	: 1.92E-05	: 1.92E-05	: 1.92E-05	: 1.92E-05
INFANT	: 1.10E-05	: 1.10E-05	: 1.32E-09	: 1.10E-05	: 1.10E-05	: 1.10E-05	: 1.10E-05	: 1.10E-05

TABLE IV-A-17

FORT CALHOUN ANNUAL 2020, DOSE PROJECTIONS
 SPECIAL LOCATION NO. 17 VEG
 AT 2.23 MILES NNE

ANNUAL_BETA_AIR_DOSE = 1.05E-04 MILLRADS
 ANNUAL_GAMMA_AIR_DOSE = 9.23E-07 MILLRADS

PATHWAY	T.BODY	GI-TRACT	BONE	LIVER	KIDNEY	THYROID	LUNG	SKIN
PLUME	: 6.05E-07	: 6.05E-07	: 6.05E-07	: 6.05E-07	: 6.05E-07	: 6.05E-07	: 1.61E-06	: 7.26E-05
GROUND	: 5.50E-08	: 5.50E-08	: 5.50E-08	: 5.50E-08	: 5.50E-08	: 5.50E-08	: 5.50E-08	: 6.42E-08
VEGET	:	:	:	:	:	:	:	:
ADULT	: 2.19E-05	: 2.18E-05	: 2.88E-08	: 2.19E-05	: 2.19E-05	: 2.18E-05	: 2.18E-05	: 2.18E-05
TEEN	: 2.50E-05	: 2.50E-05	: 4.59E-08	: 2.50E-05	: 2.50E-05	: 2.50E-05	: 2.50E-05	: 2.50E-05
CHILD	: 3.88E-05	: 3.88E-05	: 1.08E-07	: 3.89E-05	: 3.88E-05	: 3.88E-05	: 3.88E-05	: 3.88E-05

TABLE IV-A-18

FORT CALHOUN ANNUAL 2020, DOSE PROJECTIONS
 SPECIAL LOCATION NO. 18 VEG
 AT 3.20 MILES NE

ANNUAL_BETA_AIR_DOSE = 3.87E-05 MILLRADS
 ANNUAL_GAMMA_AIR_DOSE = 3.41E-07 MILLRADS

PATHWAY	T.BODY	GI-TRACT	BONE	LIVER	KIDNEY	THYROID	LUNG	SKIN
PLUME	: 2.23E-07	: 2.23E-07	: 2.23E-07	: 2.23E-07	: 2.23E-07	: 2.23E-07	: 5.94E-07	: 2.68E-05
GROUND	: 1.38E-08	: 1.38E-08	: 1.38E-08	: 1.38E-08	: 1.38E-08	: 1.38E-08	: 1.38E-08	: 1.60E-08
VEGET	:	:	:	:	:	:	:	:
ADULT	: 8.08E-06	: 8.07E-06	: 7.20E-09	: 8.08E-06	: 8.08E-06	: 8.07E-06	: 8.07E-06	: 8.07E-06
TEEN	: 9.24E-06	: 9.23E-06	: 1.15E-08	: 9.25E-06	: 9.24E-06	: 9.23E-06	: 9.23E-06	: 9.23E-06
CHILD	: 1.43E-05	: 1.43E-05	: 2.71E-08	: 1.44E-05	: 1.43E-05	: 1.43E-05	: 1.43E-05	: 1.43E-05

TABLE IV-A-19

FORT CALHOUN ANNUAL 2020, DOSE PROJECTIONS
 SPECIAL LOCATION NO. 19 VEG
 AT 4.79 MILES ENE

ANNUAL_BETA_AIR_DOSE = 2.00E-05 MILLRADS
 ANNUAL_GAMMA_AIR_DOSE = 1.77E-07 MILLRADS

PATHWAY	T.BODY	GI-TRACT	BONE	LIVER	KIDNEY	THYROID	LUNG	SKIN
PLUME	: 1.16E-07	: 1.16E-07	: 1.16E-07	: 1.16E-07	: 1.16E-07	: 1.16E-07	: 3.08E-07	: 1.39E-05
GROUND	: 4.45E-09	: 4.45E-09	: 4.45E-09	: 4.45E-09	: 4.45E-09	: 4.45E-09	: 4.45E-09	: 5.19E-09
VEGET	:	:	:	:	:	:	:	:
ADULT	: 4.18E-06	: 4.18E-06	: 2.33E-09	: 4.18E-06	: 4.18E-06	: 4.18E-06	: 4.18E-06	: 4.18E-06
TEEN	: 4.78E-06	: 4.78E-06	: 3.71E-09	: 4.78E-06	: 4.78E-06	: 4.78E-06	: 4.78E-06	: 4.78E-06
CHILD	: 7.42E-06	: 7.42E-06	: 8.76E-09	: 7.43E-06	: 7.43E-06	: 7.42E-06	: 7.42E-06	: 7.42E-06

TABLE IV-A-20

FORT CALHOUN ANNUAL 2020, DOSE PROJECTIONS
 SPECIAL LOCATION NO. 20 VEG
 AT 4.22 MILES ESE

ANNUAL_BETA_AIR_DOSE = 4.55E-05 MILLRADS
 ANNUAL_GAMMA_AIR_DOSE = 4.01E-07 MILLRADS

PATHWAY	T.BODY	GI-TRACT	BONE	LIVER	KIDNEY	THYROID	LUNG	SKIN
PLUME	: 2.63E-07	: 2.63E-07	: 2.63E-07	: 2.63E-07	: 2.63E-07	: 2.63E-07	: 6.99E-07	: 3.16E-05
GROUND	: 1.24E-08	: 1.24E-08	: 1.24E-08	: 1.24E-08	: 1.24E-08	: 1.24E-08	: 1.24E-08	: 1.44E-08
VEGET	:	:	:	:	:	:	:	:
ADULT	: 9.50E-06	: 9.50E-06	: 6.48E-09	: 9.51E-06	: 9.50E-06	: 9.50E-06	: 9.50E-06	: 9.50E-06
TEEN	: 1.09E-05	: 1.09E-05	: 1.03E-08	: 1.09E-05	: 1.09E-05	: 1.09E-05	: 1.09E-05	: 1.09E-05
CHILD	: 1.69E-05	: 1.69E-05	: 2.44E-08	: 1.69E-05	: 1.69E-05	: 1.69E-05	: 1.69E-05	: 1.69E-05

TABLE IV-A-21

FORT CALHOUN ANNUAL 2020, DOSE PROJECTIONS
 SPECIAL LOCATION NO. 21 VEG
 AT 1.99 MILES SE

ANNUAL_BETA_AIR_DOSE = 2.12E-04 MILLRADS
 ANNUAL_GAMMA_AIR_DOSE = 1.87E-06 MILLRADS

PATHWAY	T.BODY	GI-TRACT	BONE	LIVER	KIDNEY	THYROID	LUNG	SKIN
PLUME	: 1.22E-06	: 1.22E-06	: 1.22E-06	: 1.22E-06	: 1.22E-06	: 1.22E-06	: 3.25E-06	: 1.47E-04
GROUND	: 1.19E-07	: 1.19E-07	: 1.19E-07	: 1.19E-07	: 1.19E-07	: 1.19E-07	: 1.19E-07	: 1.39E-07
VEGET	:	:	:	:	:	:	:	:
ADULT	: 4.42E-05	: 4.42E-05	: 6.24E-08	: 4.43E-05	: 4.42E-05	: 4.42E-05	: 4.42E-05	: 4.42E-05
TEEN	: 5.06E-05	: 5.05E-05	: 9.94E-08	: 5.06E-05	: 5.06E-05	: 5.05E-05	: 5.05E-05	: 5.05E-05
CHILD	: 7.85E-05	: 7.85E-05	: 2.35E-07	: 7.87E-05	: 7.85E-05	: 7.85E-05	: 7.85E-05	: 7.85E-05

TABLE IV-A-22

FORT CALHOUN ANNUAL 2020, DOSE PROJECTIONS
 SPECIAL LOCATION NO. 22 VEG
 AT 0.94 MILES SSE

ANNUAL_BETA_AIR_DOSE = 6.82E-04 MILLRADS
 ANNUAL_GAMMA_AIR_DOSE = 6.02E-06 MILLRADS

PATHWAY	T.BODY	GI-TRACT	BONE	LIVER	KIDNEY	THYROID	LUNG	SKIN
PLUME	: 3.94E-06	: 3.94E-06	: 3.94E-06	: 3.94E-06	: 3.94E-06	: 3.94E-06	: 1.05E-05	: 4.74E-04
GROUND	: 1.24E-06	: 1.24E-06	: 1.24E-06	: 1.24E-06	: 1.24E-06	: 1.24E-06	: 1.24E-06	: 1.44E-06
VEGET	:	:	:	:	:	:	:	:
ADULT	: 1.43E-04	: 1.42E-04	: 6.48E-07	: 1.43E-04	: 1.43E-04	: 1.42E-04	: 1.43E-04	: 1.42E-04
TEEN	: 1.63E-04	: 1.63E-04	: 1.03E-06	: 1.64E-04	: 1.63E-04	: 1.63E-04	: 1.63E-04	: 1.63E-04
CHILD	: 2.53E-04	: 2.53E-04	: 2.44E-06	: 2.55E-04	: 2.54E-04	: 2.53E-04	: 2.53E-04	: 2.53E-04

TABLE IV-A-23

FORT CALHOUN ANNUAL 2020, DOSE PROJECTIONS
 SPECIAL LOCATION NO. 23 VEG
 AT 0.73 MILES S

ANNUAL_BETA_AIR_DOSE = 9.55E-04 MILLRADS
 ANNUAL_GAMMA_AIR_DOSE = 8.43E-06 MILLRADS

PATHWAY	T.BODY	GI-TRACT	BONE	LIVER	KIDNEY	THYROID	LUNG	SKIN
PLUME	: 5.52E-06	: 5.52E-06	: 5.52E-06	: 5.52E-06	: 5.52E-06	: 5.52E-06	: 1.47E-05	: 6.63E-04
GROUND	: 1.24E-06	: 1.24E-06	: 1.24E-06	: 1.24E-06	: 1.24E-06	: 1.24E-06	: 1.24E-06	: 1.44E-06
VEGET	:	:	:	:	:	:	:	:
ADULT	: 2.00E-04	: 1.99E-04	: 6.48E-07	: 2.00E-04	: 2.00E-04	: 1.99E-04	: 2.00E-04	: 1.99E-04
TEEN	: 2.29E-04	: 2.28E-04	: 1.03E-06	: 2.29E-04	: 2.29E-04	: 2.28E-04	: 2.28E-04	: 2.28E-04
CHILD	: 3.55E-04	: 3.54E-04	: 2.44E-06	: 3.57E-04	: 3.55E-04	: 3.54E-04	: 3.55E-04	: 3.54E-04

TABLE IV-A-24

FORT CALHOUN ANNUAL 2020, DOSE PROJECTIONS
 SPECIAL LOCATION NO. 24 VEG
 AT 0.99 MILES SSW

ANNUAL_BETA_AIR_DOSE = 3.87E-04 MILLRADS
 ANNUAL_GAMMA_AIR_DOSE = 3.41E-06 MILLRADS

PATHWAY	T.BODY	GI-TRACT	BONE	LIVER	KIDNEY	THYROID	LUNG	SKIN
PLUME	: 2.23E-06	: 2.23E-06	: 2.23E-06	: 2.23E-06	: 2.23E-06	: 2.23E-06	: 5.94E-06	: 2.68E-04
GROUND	: 2.61E-07	: 2.61E-07	: 2.61E-07	: 2.61E-07	: 2.61E-07	: 2.61E-07	: 2.61E-07	: 3.05E-07
VEGET	:	:	:	:	:	:	:	:
ADULT	: 8.09E-05	: 8.07E-05	: 1.37E-07	: 8.09E-05	: 8.08E-05	: 8.07E-05	: 8.08E-05	: 8.07E-05
TEEN	: 9.24E-05	: 9.23E-05	: 2.18E-07	: 9.26E-05	: 9.24E-05	: 9.23E-05	: 9.24E-05	: 9.23E-05
CHILD	: 1.43E-04	: 1.43E-04	: 5.15E-07	: 1.44E-04	: 1.44E-04	: 1.43E-04	: 1.43E-04	: 1.43E-04

TABLE IV-A-25

FORT CALHOUN ANNUAL 2020, DOSE PROJECTIONS
 SPECIAL LOCATION NO. 25 VEG
 AT 1.43 MILES SW

ANNUAL_BETA_AIR_DOSE = 1.41E-04 MILLRADS
 ANNUAL_GAMMA_AIR_DOSE = 1.24E-06 MILLRADS

PATHWAY	T.BODY	GI-TRACT	BONE	LIVER	KIDNEY	THYROID	LUNG	SKIN
PLUME	: 8.15E-07	: 8.15E-07	: 8.15E-07	: 8.15E-07	: 8.15E-07	: 8.15E-07	: 2.17E-06	: 9.79E-05
GROUND	: 6.88E-08	: 6.88E-08	: 6.88E-08	: 6.88E-08	: 6.88E-08	: 6.88E-08	: 6.88E-08	: 8.02E-08
VEGET	:	:	:	:	:	:	:	:
ADULT	: 2.95E-05	: 2.94E-05	: 3.60E-08	: 2.95E-05	: 2.95E-05	: 2.94E-05	: 2.94E-05	: 2.94E-05
TEEN	: 3.37E-05	: 3.37E-05	: 5.74E-08	: 3.37E-05	: 3.37E-05	: 3.37E-05	: 3.37E-05	: 3.37E-05
CHILD	: 5.23E-05	: 5.23E-05	: 1.35E-07	: 5.24E-05	: 5.23E-05	: 5.23E-05	: 5.23E-05	: 5.23E-05

TABLE IV-A-26

FORT CALHOUN ANNUAL 2020, DOSE PROJECTIONS
 SPECIAL LOCATION NO. 26 VEG
 AT 1.13 MILES WSW

ANNUAL_BETA_AIR_DOSE = 2.96E-04 MILLRADS
 ANNUAL_GAMMA_AIR_DOSE = 2.61E-06 MILLRADS

PATHWAY	T.BODY	GI-TRACT	BONE	LIVER	KIDNEY	THYROID	LUNG	SKIN
PLUME	: 1.71E-06	: 1.71E-06	: 1.71E-06	: 1.71E-06	: 1.71E-06	: 1.71E-06	: 4.54E-06	: 2.05E-04
GROUND	: 1.60E-07	: 1.60E-07	: 1.60E-07	: 1.60E-07	: 1.60E-07	: 1.60E-07	: 1.60E-07	: 1.87E-07
VEGET	:	:	:	:	:	:	:	:
ADULT	: 6.18E-05	: 6.17E-05	: 8.40E-08	: 6.19E-05	: 6.18E-05	: 6.17E-05	: 6.17E-05	: 6.17E-05
TEEN	: 7.07E-05	: 7.06E-05	: 1.34E-07	: 7.08E-05	: 7.07E-05	: 7.06E-05	: 7.06E-05	: 7.06E-05
CHILD	: 1.10E-04	: 1.10E-04	: 3.16E-07	: 1.10E-04	: 1.10E-04	: 1.10E-04	: 1.10E-04	: 1.10E-04

TABLE IV-A-27

FORT CALHOUN ANNUAL 2020, DOSE PROJECTIONS
 SPECIAL LOCATION NO. 27 VEG
 AT 2.65 MILES WNW

ANNUAL_BETA_AIR_DOSE = 7.28E-05 MILLRADS
 ANNUAL_GAMMA_AIR_DOSE = 6.42E-07 MILLRADS

PATHWAY	T.BODY	GI-TRACT	BONE	LIVER	KIDNEY	THYROID	LUNG	SKIN
PLUME	: 4.21E-07	: 4.21E-07	: 4.21E-07	: 4.21E-07	: 4.21E-07	: 4.21E-07	: 1.12E-06	: 5.05E-05
GROUND	: 3.39E-08	: 3.39E-08	: 3.39E-08	: 3.39E-08	: 3.39E-08	: 3.39E-08	: 3.39E-08	: 3.96E-08
VEGET	:	:	:	:	:	:	:	:
ADULT	: 1.52E-05	: 1.52E-05	: 1.78E-08	: 1.52E-05	: 1.52E-05	: 1.52E-05	: 1.52E-05	: 1.52E-05
TEEN	: 1.74E-05	: 1.74E-05	: 2.83E-08	: 1.74E-05	: 1.74E-05	: 1.74E-05	: 1.74E-05	: 1.74E-05
CHILD	: 2.70E-05	: 2.70E-05	: 6.68E-08	: 2.71E-05	: 2.70E-05	: 2.70E-05	: 2.70E-05	: 2.70E-05

TABLE IV-A-28

FORT CALHOUN ANNUAL 2020, DOSE PROJECTIONS
 SPECIAL LOCATION NO. 28 VEG
 AT 2.40 MILES NW

ANNUAL_BETA_AIR_DOSE = 1.18E-04 MILLRADS
 ANNUAL_GAMMA_AIR_DOSE = 1.04E-06 MILLRADS

PATHWAY	T.BODY	GI-TRACT	BONE	LIVER	KIDNEY	THYROID	LUNG	SKIN
PLUME	: 6.84E-07	: 6.84E-07	: 6.84E-07	: 6.84E-07	: 6.84E-07	: 6.84E-07	: 1.82E-06	: 8.21E-05
GROUND	: 8.71E-08	: 8.71E-08	: 8.71E-08	: 8.71E-08	: 8.71E-08	: 8.71E-08	: 8.71E-08	: 1.02E-07
VEGET	:	:	:	:	:	:	:	:
ADULT	: 2.47E-05	: 2.47E-05	: 4.56E-08	: 2.48E-05	: 2.47E-05	: 2.47E-05	: 2.47E-05	: 2.47E-05
TEEN	: 2.83E-05	: 2.82E-05	: 7.27E-08	: 2.83E-05	: 2.83E-05	: 2.82E-05	: 2.83E-05	: 2.82E-05
CHILD	: 4.39E-05	: 4.39E-05	: 1.72E-07	: 4.40E-05	: 4.39E-05	: 4.39E-05	: 4.39E-05	: 4.39E-05

TABLE IV-A-29

FORT CALHOUN ANNUAL 2020, DOSE PROJECTIONS
 SPECIAL LOCATION NO. 29 BEEF
 AT 4.72 MILES NNE

ANNUAL_BETA_AIR_DOSE = 2.50E-05 MILLRADS
 ANNUAL_GAMMA_AIR_DOSE = 2.21E-07 MILLRADS

PATHWAY	T.BODY	GI-TRACT	BONE	LIVER	KIDNEY	THYROID	LUNG	SKIN
PLUME	: 1.45E-07	: 1.45E-07	: 1.45E-07	: 1.45E-07	: 1.45E-07	: 1.45E-07	: 3.85E-07	: 1.74E-05
GROUND	: 1.01E-08	: 1.01E-08	: 1.01E-08	: 1.01E-08	: 1.01E-08	: 1.01E-08	: 1.01E-08	: 1.18E-08
MEAT	:	:	:	:	:	:	:	:
ADULT	: 7.51E-07	: 7.51E-07	: 5.51E-10	: 7.52E-07	: 7.51E-07	: 7.51E-07	: 7.51E-07	: 7.51E-07
TEEN	: 4.48E-07	: 4.47E-07	: 4.57E-10	: 4.48E-07	: 4.48E-07	: 4.47E-07	: 4.47E-07	: 4.47E-07
CHILD	: 5.42E-07	: 5.42E-07	: 8.42E-10	: 5.43E-07	: 5.42E-07	: 5.42E-07	: 5.42E-07	: 5.42E-07

TABLE IV-A-30

FORT CALHOUN ANNUAL 2020, DOSE PROJECTIONS
 SPECIAL LOCATION NO. 30 BEEF
 AT 4.91 MILES E

ANNUAL_BETA_AIR_DOSE = 2.27E-05 MILLRADS
 ANNUAL_GAMMA_AIR_DOSE = 2.01E-07 MILLRADS

PATHWAY	T.BODY	GI-TRACT	BONE	LIVER	KIDNEY	THYROID	LUNG	SKIN
PLUME	: 1.31E-07	: 1.31E-07	: 1.31E-07	: 1.31E-07	: 1.31E-07	: 1.31E-07	: 3.50E-07	: 1.58E-05
GROUND	: 6.42E-09	: 6.42E-09	: 6.42E-09	: 6.42E-09	: 6.42E-09	: 6.42E-09	: 6.42E-09	: 7.49E-09
MEAT	:	:	:	:	:	:	:	:
ADULT	: 6.83E-07	: 6.83E-07	: 3.51E-10	: 6.83E-07	: 6.83E-07	: 6.83E-07	: 6.83E-07	: 6.83E-07
TEEN	: 4.07E-07	: 4.07E-07	: 2.91E-10	: 4.07E-07	: 4.07E-07	: 4.07E-07	: 4.07E-07	: 4.07E-07
CHILD	: 4.93E-07	: 4.93E-07	: 5.36E-10	: 4.93E-07	: 4.93E-07	: 4.93E-07	: 4.93E-07	: 4.93E-07

TABLE IV-A-31

FORT CALHOUN ANNUAL 2020, DOSE PROJECTIONS
 SPECIAL LOCATION NO. 31 BEEF
 AT 0.66 MILES S

ANNUAL_BETA_AIR_DOSE = 1.21E-03 MILLRADS
 ANNUAL_GAMMA_AIR_DOSE = 1.06E-05 MILLRADS

PATHWAY	T.BODY	GI-TRACT	BONE	LIVER	KIDNEY	THYROID	LUNG	SKIN
PLUME	: 6.97E-06	: 6.97E-06	: 6.97E-06	: 6.97E-06	: 6.97E-06	: 6.97E-06	: 1.85E-05	: 8.37E-04
GROUND	: 1.56E-06	: 1.56E-06	: 1.56E-06	: 1.56E-06	: 1.56E-06	: 1.56E-06	: 1.56E-06	: 1.82E-06
MEAT	:	:	:	:	:	:	:	:
ADULT	: 3.63E-05	: 3.62E-05	: 8.51E-08	: 3.63E-05	: 3.62E-05	: 3.62E-05	: 3.62E-05	: 3.62E-05
TEEN	: 2.16E-05	: 2.16E-05	: 7.07E-08	: 2.16E-05	: 2.16E-05	: 2.16E-05	: 2.16E-05	: 2.16E-05
CHILD	: 2.61E-05	: 2.61E-05	: 1.30E-07	: 2.62E-05	: 2.62E-05	: 2.61E-05	: 2.61E-05	: 2.61E-05

TABLE IV-A-32

FORT CALHOUN ANNUAL 2020, DOSE PROJECTIONS
 SPECIAL LOCATION NO. 32 BEEF
 AT 0.76 MILES SW

ANNUAL_BETA_AIR_DOSE = 6.82E-04 MILLRADS
 ANNUAL_GAMMA_AIR_DOSE = 6.02E-06 MILLRADS

PATHWAY	T.BODY	GI-TRACT	BONE	LIVER	KIDNEY	THYROID	LUNG	SKIN
PLUME	: 3.94E-06	: 3.94E-06	: 3.94E-06	: 3.94E-06	: 3.94E-06	: 3.94E-06	: 1.05E-05	: 4.74E-04
GROUND	: 3.58E-07	: 3.58E-07	: 3.58E-07	: 3.58E-07	: 3.58E-07	: 3.58E-07	: 3.58E-07	: 4.17E-07
MEAT	:	:	:	:	:	:	:	:
ADULT	: 2.05E-05	: 2.05E-05	: 1.95E-08	: 2.05E-05	: 2.05E-05	: 2.05E-05	: 2.05E-05	: 2.05E-05
TEEN	: 1.22E-05	: 1.22E-05	: 1.62E-08	: 1.22E-05	: 1.22E-05	: 1.22E-05	: 1.22E-05	: 1.22E-05
CHILD	: 1.48E-05	: 1.48E-05	: 2.99E-08	: 1.48E-05	: 1.48E-05	: 1.48E-05	: 1.48E-05	: 1.48E-05

TABLE IV-A-33

FORT CALHOUN ANNUAL 2020, DOSE PROJECTIONS
 SPECIAL LOCATION NO. 33 BEEF
 AT 3.25 MILES W

ANNUAL_BETA_AIR_DOSE = 3.18E-05 MILLRADS
 ANNUAL_GAMMA_AIR_DOSE = 2.81E-07 MILLRADS

PATHWAY	T.BODY	GI-TRACT	BONE	LIVER	KIDNEY	THYROID	LUNG	SKIN
PLUME	: 1.84E-07	: 1.84E-07	: 1.84E-07	: 1.84E-07	: 1.84E-07	: 1.84E-07	: 4.89E-07	: 2.21E-05
GROUND	: 1.38E-08	: 1.38E-08	: 1.38E-08	: 1.38E-08	: 1.38E-08	: 1.38E-08	: 1.38E-08	: 1.60E-08
MEAT	:	:	:	:	:	:	:	:
ADULT	: 9.56E-07	: 9.56E-07	: 7.51E-10	: 9.57E-07	: 9.56E-07	: 9.56E-07	: 9.56E-07	: 9.56E-07
TEEN	: 5.70E-07	: 5.69E-07	: 6.24E-10	: 5.70E-07	: 5.70E-07	: 5.69E-07	: 5.69E-07	: 5.69E-07
CHILD	: 6.90E-07	: 6.90E-07	: 1.15E-09	: 6.91E-07	: 6.90E-07	: 6.90E-07	: 6.90E-07	: 6.90E-07

TABLE IV-A-34

FORT CALHOUN ANNUAL 2020, DOSE PROJECTIONS
 SPECIAL LOCATION NO. 34 BEEF
 AT 4.59 MILES WNW

ANNUAL_BETA_AIR_DOSE = 2.96E-05 MILLRADS
 ANNUAL_GAMMA_AIR_DOSE = 2.61E-07 MILLRADS

PATHWAY	T.BODY	GI-TRACT	BONE	LIVER	KIDNEY	THYROID	LUNG	SKIN
PLUME	: 1.71E-07	: 1.71E-07	: 1.71E-07	: 1.71E-07	: 1.71E-07	: 1.71E-07	: 4.54E-07	: 2.05E-05
GROUND	: 1.10E-08	: 1.10E-08	: 1.10E-08	: 1.10E-08	: 1.10E-08	: 1.10E-08	: 1.10E-08	: 1.28E-08
MEAT	:	:	:	:	:	:	:	:
ADULT	: 8.88E-07	: 8.87E-07	: 6.01E-10	: 8.88E-07	: 8.88E-07	: 8.87E-07	: 8.87E-07	: 8.87E-07
TEEN	: 5.29E-07	: 5.29E-07	: 4.99E-10	: 5.29E-07	: 5.29E-07	: 5.29E-07	: 5.29E-07	: 5.29E-07
CHILD	: 6.41E-07	: 6.40E-07	: 9.19E-10	: 6.41E-07	: 6.41E-07	: 6.40E-07	: 6.41E-07	: 6.40E-07

TABLE IV-A-35

FORT CALHOUN ANNUAL 2020, DOSE PROJECTIONS
 SPECIAL LOCATION NO. 35 GOAT
 AT 3.30 MILES SSW

ANNUAL_BETA_AIR_DOSE = 2.07E-05 MILLRADS
 ANNUAL_GAMMA_AIR_DOSE = 1.83E-07 MILLRADS

PATHWAY	T.BODY	GI-TRACT	BONE	LIVER	KIDNEY	THYROID	LUNG	SKIN
PLUME	: 1.20E-07	: 1.20E-07	: 1.20E-07	: 1.20E-07	: 1.20E-07	: 1.20E-07	: 3.18E-07	: 1.44E-05
GROUND	: 1.05E-08	: 1.05E-08	: 1.05E-08	: 1.05E-08	: 1.05E-08	: 1.05E-08	: 1.05E-08	: 1.23E-08
GOATMILK :	:	:	:	:	:	:	:	:
ADULT	: 2.99E-06	: 2.98E-06	: 1.46E-08	: 3.00E-06	: 2.98E-06	: 2.98E-06	: 2.98E-06	: 2.98E-06
TEEN	: 3.88E-06	: 3.87E-06	: 2.65E-08	: 3.91E-06	: 3.88E-06	: 3.87E-06	: 3.88E-06	: 3.87E-06
CHILD	: 6.14E-06	: 6.13E-06	: 6.39E-08	: 6.20E-06	: 6.15E-06	: 6.13E-06	: 6.14E-06	: 6.13E-06
INFANT	: 9.32E-06	: 9.31E-06	: 1.02E-07	: 9.43E-06	: 9.34E-06	: 9.31E-06	: 9.32E-06	: 9.31E-06

TABLE IV-A-36

FORT CALHOUN ANNUAL 2020, DOSE PROJECTIONS
 SPECIAL LOCATION NO. 36 GOAT
 AT 4.20 MILES SW

ANNUAL_BETA_AIR_DOSE = 1.46E-05 MILLRADS
 ANNUAL_GAMMA_AIR_DOSE = 1.28E-07 MILLRADS

PATHWAY	T.BODY	GI-TRACT	BONE	LIVER	KIDNEY	THYROID	LUNG	SKIN
PLUME	: 8.41E-08	: 8.41E-08	: 8.41E-08	: 8.41E-08	: 8.41E-08	: 8.41E-08	: 2.24E-07	: 1.01E-05
GROUND	: 5.50E-09	: 5.50E-09	: 5.50E-09	: 5.50E-09	: 5.50E-09	: 5.50E-09	: 5.50E-09	: 6.42E-09
GOATMILK	:	:	:	:	:	:	:	:
ADULT	: 2.10E-06	: 2.09E-06	: 7.63E-09	: 2.10E-06	: 2.10E-06	: 2.09E-06	: 2.09E-06	: 2.09E-06
TEEN	: 2.73E-06	: 2.72E-06	: 1.38E-08	: 2.74E-06	: 2.73E-06	: 2.72E-06	: 2.73E-06	: 2.72E-06
CHILD	: 4.32E-06	: 4.31E-06	: 3.33E-08	: 4.35E-06	: 4.32E-06	: 4.31E-06	: 4.32E-06	: 4.31E-06
INFANT	: 6.55E-06	: 6.55E-06	: 5.32E-08	: 6.61E-06	: 6.56E-06	: 6.55E-06	: 6.55E-06	: 6.55E-06

TABLE IV-B-1

FORT CALHOUN 1 DOSE CONTRIBUTIONS FROM GASEOUS EFFLUENTS
UNRESTRICTED AREA BOUNDARY
JANUARY 1, 2020 TO DECEMBER 31, 2020

MAXIMUM SITE BOUNDARY GAMMA AIR DOSE - 1.26E-04 MILLRADS

MAXIMUM SITE BOUNDARY BETA AIR DOSE - 1.43E-02 MILLRADS

TABLE IV-C-1

FORT CALHOUN ANNUAL 2020, DOSE PROJECTIONS
ALARA ANNUAL INTEGRATED POPULATION DOSE SUMMARY (PERSON-REM)

PATHWAY	T.BODY	GI-TRACT	BONE	LIVER	KIDNEY	THYROID	LUNG	SKIN
PLUME	: 1.26E-05	: 1.26E-05	: 1.26E-05	: 1.26E-05	: 1.26E-05	: 1.26E-05	: 4.20E-05	: 2.12E-03
	: 1.38%	: 1.38%	: 85.92%	: 1.38%	: 1.38%	: 1.38%	: 4.45%	: 70.14%
GROUND	: 1.22E-06	: 1.22E-06	: 1.22E-06	: 1.22E-06	: 1.22E-06	: 1.22E-06	: 1.22E-06	: 1.43E-06
	: 0.13%	: 0.13%	: 8.32%	: 0.13%	: 0.13%	: 0.13%	: 0.13%	: 0.05%
INHAL	: 3.46E-04	: 3.46E-04	: 1.70E-08	: 3.46E-04	: 3.46E-04	: 3.46E-04	: 3.46E-04	: 3.46E-04
	: 37.84%	: 37.86%	: 0.12%	: 37.82%	: 37.85%	: 37.86%	: 36.68%	: 11.46%
VEGET	: 3.90E-04	: 3.89E-04	: 5.37E-07	: 3.90E-04	: 3.90E-04	: 3.89E-04	: 3.89E-04	: 3.89E-04
	: 42.56%	: 42.55%	: 3.65%	: 42.58%	: 42.56%	: 42.55%	: 41.23%	: 12.88%
COW MILK	: 7.76E-05	: 7.76E-05	: 2.17E-07	: 7.78E-05	: 7.76E-05	: 7.76E-05	: 7.76E-05	: 7.76E-05
	: 8.48%	: 8.48%	: 1.48%	: 8.50%	: 8.48%	: 8.48%	: 8.22%	: 2.57%
MEAT	: 8.78E-05	: 8.78E-05	: 7.63E-08	: 8.79E-05	: 8.78E-05	: 8.78E-05	: 8.78E-05	: 8.78E-05
	: 9.60%	: 9.59%	: 0.52%	: 9.59%	: 9.59%	: 9.59%	: 9.30%	: 2.90%
TOTAL	: 9.15E-04	: 9.15E-04	: 1.47E-05	: 9.16E-04	: 9.15E-04	: 9.15E-04	: 9.44E-04	: 3.02E-03

SECTION V

DOSE FROM LIQUID EFFLUENTS
LADTAP II OUTPUT

January 1, 2020 - December 31, 2020

Radioactive Effluent Releases - First, Second, Third, and Fourth Quarters 2020

LIQUID EFFLUENTS

During the reporting period, a total of $5.61\text{E}-03$ curies of radioactive liquid materials, less tritium, dissolved noble gases, and alpha, were released to the Missouri River at an average concentration of $2.02\text{E}-08$ $\mu\text{Ci}/\text{mL}$. This represents $2.02\text{E}+00$ percent of the limits specified in Appendix B to 10 CFR 20 ($1.0\text{E}-06$ $\mu\text{Ci}/\text{mL}$ for unrestricted areas), $3.64\text{E}+00$ curies of tritium were discharged at an average diluted concentration of $1.31\text{E}-05$ $\mu\text{Ci}/\text{mL}$ or $1.31\text{E}+00$ percent of ECL ($1.0\text{E}-03$ $\mu\text{Ci}/\text{mL}$).

No gross alpha radioactivity was identified by Off-site vendor analysis of quarterly liquid composites for the reporting period.

Dilution water during the periods of release amounted to $2.77\text{E}+08$ liters, while liquid waste discharges consisted of $1.17\text{E}+06$ liters of radioactive liquid waste.

A. Potential Annual Doses to Individuals from Liquid Releases

Total body, skin, and organ mRem for liquid releases were calculated for all significant liquid pathways using the annual configuration of the LADTAP II program.

The inputs to LADTAP II for the annual period from January 1, 2020 through December 31, 2020 were as follows:

- (1) All liquid effluents were as described in Section IV except for entrained noble gases (Ar-41, Xe-131M, Xe-133M, Xe-133, Xe-135M, Xe-135, Kr-85M, Kr-87, and Kr-88).
- (2) An average dilution stream flow during periods of release was 14.73 cubic feet per second (CFS) for 2020. The average discharge rate during releases was 14.82 cubic feet per second (CFS).
- (3) Dilution factors (inverse of the mixing ratios) were computed based on Regulatory Guide 1.113 (equation 7 in Section 2.a.1 of Appendix A) for a one dimensional transport model.
- (4) Drinking water transport times of 6.6 hours to the Omaha intake and 7.0 hours to the Council Bluffs intake were used for dose calculations.
- (5) A shorewidth factor of 0.2 was used.
- (6) All dose factors, transport times from receptor to individual, and usage factors are defined by Regulatory Guide 1.109 and NUREG-0172.

The discharge site was chosen to present the most conservative estimate of mRem dose for an average adult, teenager, child, and infant. A conservative approach is also presented by the assumption that Omaha and Council Bluffs receive all drinking water from the Missouri River.

B. Potential Annual Doses to Population from Liquid Releases

The LADTAP II program in its annual configuration was also used to calculate to total body and organ doses for the population of 950,006 within a 50-mile radius of the plant (based on the 2010 census). The same input was used as in the individual cases with the addition of the following:

- (1) Dilution factors and transport times for the pathways of sport fish, commercial fish, recreation and biota were calculated based on a distance of two miles downstream as approximately the distance to the nearest recreation facility - DeSoto National Wildlife Preserve.
- (2) The total fish harvest for both sport and commercial purposes was calculated using an average commercial fish catch for Nebraska.

LOCATION IS FRESHWATER SITE

A D U L T D O S E S

PATHWAY	DOSE__ (MREM PER YEAR INTAKE)							
	SKIN	BONE	LIVER	TOTAL BODY	THYROID	KIDNEY	LUNG	GI-LLI
FISH		1.75E-01	2.39E-01	1.57E-01	4.07E-05	8.11E-02	2.70E-02	4.71E-03
DRINKING		7.74E-04	1.36E-03	1.02E-03	3.73E-04	7.07E-04	4.84E-04	3.98E-04
SHORELINE	2.56E-04	2.19E-04	2.19E-04	2.19E-04	2.19E-04	2.19E-04	2.19E-04	2.19E-04
SWIMMING		6.72E-07	6.72E-07	6.72E-07	6.72E-07	6.72E-07	6.72E-07	6.72E-07
BOATING		3.36E-07	3.36E-07	3.36E-07	3.36E-07	3.36E-07	3.36E-07	3.36E-07
TOTAL	2.56E-04	1.76E-01	2.40E-01	1.58E-01	6.33E-04	8.20E-02	2.77E-02	5.33E-03

	USAGE (KG/YR,HR/YR)	DILUTION	TIME (HR)	SHOREWIDTH FACTOR=0.2
FISH	21.0	7.3	24.00	
DRINKING	730.0	30.8	18.60	
SHORELINE	12.0	7.3	0.00	
SWIMMING	12.0	7.3	0.00	
BOATING	12.0	7.3	0.00	

T E E N A G E R D O S E S

PATHWAY	DOSE__ (MREM PER YEAR INTAKE)							
	SKIN	BONE	LIVER	TOTAL BODY	THYROID	KIDNEY	LUNG	GI-LLI
FISH		1.88E-01	2.49E-01	8.67E-02	3.13E-05	8.47E-02	3.29E-02	3.60E-03
DRINKING		7.58E-04	1.21E-03	5.92E-04	2.62E-04	5.82E-04	3.87E-04	2.80E-04
SHORELINE	1.43E-03	1.22E-03	1.22E-03	1.22E-03	1.22E-03	1.22E-03	1.22E-03	1.22E-03
SWIMMING		3.75E-06	3.75E-06	3.75E-06	3.75E-06	3.75E-06	3.75E-06	3.75E-06
BOATING		1.88E-06	1.88E-06	1.88E-06	1.88E-06	1.88E-06	1.88E-06	1.88E-06
TOTAL	1.43E-03	1.90E-01	2.51E-01	8.86E-02	1.52E-03	8.65E-02	3.45E-02	5.11E-03

	USAGE (KG/YR,HR/YR)	DILUTION	TIME (HR)	SHOREWIDTH FACTOR=0.2
FISH	16.0	7.3	24.00	
DRINKING	510.0	30.8	18.60	
SHORELINE	67.0	7.3	0.00	
SWIMMING	67.0	7.3	0.00	
BOATING	67.0	7.3	0.00	

C H I L D D O S E S

PATHWAY	DOSE (MREM PER YEAR INTAKE)							
	SKIN	BONE	LIVER	TOTAL BODY	THYROID	KIDNEY	LUNG	GI-LLI
FISH		2.36E-01	2.25E-01	3.33E-02	2.59E-05	7.34E-02	2.64E-02	1.45E-03
DRINKING		2.22E-03	2.49E-03	8.03E-04	5.04E-04	1.15E-03	7.36E-04	5.20E-04
SHORELINE	2.98E-04	2.56E-04	2.56E-04	2.56E-04	2.56E-04	2.56E-04	2.56E-04	2.56E-04
SWIMMING		7.84E-07	7.84E-07	7.84E-07	7.84E-07	7.84E-07	7.84E-07	7.84E-07
BOATING		3.92E-07	3.92E-07	3.92E-07	3.92E-07	3.92E-07	3.92E-07	3.92E-07
TOTAL	2.98E-04	2.39E-01	2.28E-01	3.44E-02	7.87E-04	7.48E-02	2.74E-02	2.22E-03

	USAGE (KG/YR,HR/YR)	DILUTION	TIME (HR)	SHOREWIDTH FACTOR=0.2
FISH	6.9	7.3	24.00	
DRINKING	510.0	30.8	18.60	
SHORELINE	14.0	7.3	0.00	
SWIMMING	14.0	7.3	0.00	
BOATING	14.0	7.3	0.00	

I N F A N T D O S E S

PATHWAY	DOSE (MREM PER YEAR INTAKE)							
	SKIN	BONE	LIVER	TOTAL BODY	THYROID	KIDNEY	LUNG	GI-LLI
FISH		0.00E+00	0.00E+00	0.00E+00	0.00E+00	0.00E+00	0.00E+00	0.00E+00
DRINKING		2.25E-03	3.00E-03	6.77E-04	4.95E-04	1.16E-03	7.66E-04	5.05E-04
SHORELINE	0.00E+00	0.00E+00	0.00E+00	0.00E+00	0.00E+00	0.00E+00	0.00E+00	0.00E+00
TOTAL	0.00E+00	2.25E-03	3.00E-03	6.77E-04	4.95E-04	1.16E-03	7.66E-04	5.05E-04

	USAGE (KG/YR,HR/YR)	DILUTION	TIME (HR)	SHOREWIDTH FACTOR=0.2
FISH	0.0	7.3	24.00	
DRINKING	330.0	30.8	18.60	

LOCATION IS SITE DISCHG.

A D U L T D O S E S

PATHWAY	DOSE (MREM PER YEAR INTAKE)							
	SKIN	BONE	LIVER	TOTAL BODY	THYROID	KIDNEY	LUNG	GI-LLI
FISH		1.28E+00	1.74E+00	1.14E+00	2.97E-04	5.92E-01	1.97E-01	3.44E-02
DRINKING		2.38E-02	4.19E-02	3.14E-02	1.15E-02	2.18E-02	1.49E-02	1.23E-02
SHORELINE	1.87E-03	1.60E-03	1.60E-03	1.60E-03	1.60E-03	1.60E-03	1.60E-03	1.60E-03
SWIMMING		4.90E-06	4.90E-06	4.90E-06	4.90E-06	4.90E-06	4.90E-06	4.90E-06
BOATING		2.45E-06	2.45E-06	2.45E-06	2.45E-06	2.45E-06	2.45E-06	2.45E-06
TOTAL	1.87E-03	1.30E+00	1.79E+00	1.18E+00	1.34E-02	6.15E-01	2.14E-01	4.82E-02

	USAGE (KG/YR,HR/YR)	DILUTION	TIME (HR)	SHOREWIDTH FACTOR=0.2
FISH	21.0	1.0	24.00	
DRINKING	730.0	1.0	12.00	
SHORELINE	12.0	1.0	0.00	
SWIMMING	12.0	1.0	0.00	
BOATING	12.0	1.0	0.00	

T E E N A G E R D O S E S

PATHWAY	DOSE (MREM PER YEAR INTAKE)							
	SKIN	BONE	LIVER	TOTAL BODY	THYROID	KIDNEY	LUNG	GI-LLI
FISH		1.37E+00	1.82E+00	6.33E-01	2.28E-04	6.18E-01	2.40E-01	2.63E-02
DRINKING		2.34E-02	3.71E-02	1.82E-02	8.09E-03	1.79E-02	1.19E-02	8.63E-03
SHORELINE	1.04E-02	8.93E-03	8.93E-03	8.93E-03	8.93E-03	8.93E-03	8.93E-03	8.93E-03
SWIMMING		2.74E-05	2.74E-05	2.74E-05	2.74E-05	2.74E-05	2.74E-05	2.74E-05
BOATING		1.37E-05	1.37E-05	1.37E-05	1.37E-05	1.37E-05	1.37E-05	1.37E-05
TOTAL	1.04E-02	1.40E+00	1.86E+00	6.60E-01	1.73E-02	6.45E-01	2.61E-01	4.39E-02

	USAGE (KG/YR,HR/YR)	DILUTION	TIME (HR)	SHOREWIDTH FACTOR=0.2
FISH	16.0	1.0	24.00	
DRINKING	510.0	1.0	12.00	
SHORELINE	67.0	1.0	0.00	
SWIMMING	67.0	1.0	0.00	
BOATING	67.0	1.0	0.00	

C H I L D D O S E S

PATHWAY	DOSE (MREM PER YEAR INTAKE)							
	SKIN	BONE	LIVER	TOTAL BODY	THYROID	KIDNEY	LUNG	GI-LLI
FISH		1.72E+00	1.65E+00	2.43E-01	1.89E-04	5.36E-01	1.93E-01	1.06E-02
DRINKING		6.84E-02	7.66E-02	2.47E-02	1.55E-02	3.53E-02	2.27E-02	1.60E-02
SHORELINE	2.18E-03	1.87E-03	1.87E-03	1.87E-03	1.87E-03	1.87E-03	1.87E-03	1.87E-03
SWIMMING		5.72E-06	5.72E-06	5.72E-06	5.72E-06	5.72E-06	5.72E-06	5.72E-06
BOATING		2.86E-06	2.86E-06	2.86E-06	2.86E-06	2.86E-06	2.86E-06	2.86E-06
TOTAL	2.18E-03	1.79E+00	1.72E+00	2.70E-01	1.76E-02	5.73E-01	2.18E-01	2.85E-02

	USAGE (KG/YR,HR/YR)	DILUTION	TIME (HR)	SHOREWIDTH FACTOR=0.2
FISH	6.9	1.0	24.00	
DRINKING	510.0	1.0	12.00	
SHORELINE	14.0	1.0	0.00	
SWIMMING	14.0	1.0	0.00	
BOATING	14.0	1.0	0.00	

I N F A N T D O S E S

PATHWAY	DOSE (MREM PER YEAR INTAKE)							
	SKIN	BONE	LIVER	TOTAL BODY	THYROID	KIDNEY	LUNG	GI-LLI
FISH		0.00E+00	0.00E+00	0.00E+00	0.00E+00	0.00E+00	0.00E+00	0.00E+00
DRINKING		6.93E-02	9.23E-02	2.09E-02	1.52E-02	3.59E-02	2.36E-02	1.55E-02
SHORELINE	0.00E+00	0.00E+00	0.00E+00	0.00E+00	0.00E+00	0.00E+00	0.00E+00	0.00E+00
TOTAL	0.00E+00	6.93E-02	9.23E-02	2.09E-02	1.52E-02	3.59E-02	2.36E-02	1.55E-02

	USAGE (KG/YR,HR/YR)	DILUTION	TIME (HR)	SHOREWIDTH FACTOR=0.2
FISH	0.0	1.0	24.00	
DRINKING	330.0	1.0	12.00	

* * * FISH CONSUMPTION POPULATION DOSES * * *
PERSON-REM

COMMERCIAL HARVEST

		-----DOSE (PERSON-REM)-----							
PATHWAY	AGE GROUP	USAGE	BONE	LIVER	TOTAL BODY	THYROID	KIDNEY	LUNG	GI-LLI
FISH	ADULT	4.18E+06	5.78E-02	7.89E-02	5.17E-02	1.34E-05	2.68E-02	8.91E-03	1.55E-03
FISH	TEENAGER	4.88E+05	9.49E-03	1.26E-02	4.39E-03	1.58E-06	4.28E-03	1.66E-03	1.82E-04
FISH	CHILD	3.38E+05	1.92E-02	1.83E-02	2.71E-03	2.10E-06	5.96E-03	2.15E-03	1.18E-04
FISH	TOTAL	5.01E+06	8.65E-02	1.10E-01	5.88E-02	1.71E-05	3.70E-02	1.27E-02	1.85E-03

LOCATION DILUTION CATCH TIME (HR) -INCLUDES FOOD PROCESSING TIME OF 2.40E+02 HR POPULATION=8.53E+05
 7.30E+00 7.30E+04 2.41E+02

AVERAGE INDIVIDUAL CONSUMPTION (KG/YR) ADULT=6.90E+00 TEEN=5.20E+00 CHILD=2.20E+00

NEPA DOSES

NOTE--TOTAL NEPA DOSE INCLUDES SPORT CATCH

		-----DOSE (PERSON-REM)-----							
PATHWAY	AGE GROUP	USAGE	BONE	LIVER	TOTAL BODY	THYROID	KIDNEY	LUNG	GI-LLI
FISH	ADULT	1.22E+05	1.02E+00	1.39E+00	9.08E-01	2.36E-04	4.71E-01	1.57E-01	2.73E-02
FISH	TEENAGER	1.42E+04	1.67E-01	2.21E-01	7.71E-02	2.78E-05	7.53E-02	2.93E-02	3.20E-03
FISH	CHILD	9.85E+03	3.37E-01	3.22E-01	4.76E-02	3.69E-05	1.05E-01	3.77E-02	2.07E-03
FISH	TOTAL	1.46E+05	1.52E+00	1.93E+00	1.03E+00	3.01E-04	6.51E-01	2.24E-01	3.26E-02

* * * POPULATION WATER CONSUMPTION DOSES * * *

SUPPLIER-OMAHA

		-----DOSE (PERSON-REM)-----							
PATHWAY	AGE GROUP	USAGE	BONE	LIVER	TOTAL BODY	THYROID	KIDNEY	LUNG	GI-LLI
DRINKING	ADULT	1.39E+08	1.47E-01	2.59E-01	1.94E-01	7.09E-02	1.35E-01	9.21E-02	7.58E-02
DRINKING	TEENAGER	1.51E+07	2.25E-02	3.58E-02	1.76E-02	7.79E-03	1.73E-02	1.15E-02	8.31E-03
DRINKING	CHILD	2.48E+07	1.08E-01	1.21E-01	3.90E-02	2.45E-02	5.57E-02	3.57E-02	2.52E-02
DRINKING	TOTAL	1.79E+08	2.78E-01	4.15E-01	2.51E-01	1.03E-01	2.07E-01	1.39E-01	1.09E-01

POPULATION=5.29E+05 DILUTION=3.08E+01 TRANSIT TIME=3.06E+01 HR (INCLUDING 24 HR FOR TREATMENT FACILITY)

AVERAGE INDIVIDUAL CONSUMPTION (L/YR) ADULT=3.70E+02 TEEN=2.60E+02 CHILD=2.60E+02

-----CUMULATIVE TOTAL-----

PATHWAY	AGE GROUP	USAGE	BONE	LIVER	TOTAL BODY	THYROID	KIDNEY	LUNG	GI-LLI
DRINKING	CUMUL TOTAL	2.08E+08	3.23E-01	4.83E-01	2.91E-01	1.20E-01	2.41E-01	1.62E-01	1.27E-01

HYDROSPHERE TRITIUM DOSE

AVERAGE INDIVIDUAL WATER CONSUMPTION = 3.0 L/DAY

PATHWAY	AGE GROUP	USAGE	BONE	LIVER	TOTAL BODY	THYROID	KIDNEY	LUNG	GI-LLI
WATER	TOTAL	2.86E+11	0.00E+00	2.77E-05	2.77E-05	2.77E-05	2.77E-05	2.77E-05	2.77E-05

* * * RECREATION POPULATION DOSES * * *

LOCATION- DOWN STREAM SWIMMING

DILUTION= 7.30E+00 TRANSIT TIME= 6.70E-01 HR SWF= 0.2

PATHWAY	AGE GROUP	USAGE	DOSE (PERSON-REM)		
			SKIN	TOTAL BODY	THYROID
SHORELINE	TOTAL POPUL	4.10E+07	8.73E-01	7.48E-01	7.48E-01

LOCATION- DOWN STREAM SWIMMING

DILUTION= 7.30E+00 TRANSIT TIME= 6.70E-01 HR

PATHWAY	AGE GROUP	USAGE	DOSE (PERSON-REM)		
			SKIN	TOTAL BODY	THYROID
SWIMMING	TOTAL POPUL	4.10E+07		2.30E-03	2.30E-03

LOCATION- DOWN STREAM BOATING

DILUTION= 7.30E+00 TRANSIT TIME= 6.70E-01 HR

PATHWAY	AGE GROUP	USAGE	DOSE (PERSON-REM)		
			SKIN	TOTAL BODY	THYROID
BOATING	TOTAL POPUL	4.10E+07		1.15E-03	1.15E-03

* * * DOSE TO BIOTA * * *
MRADS PER YEAR

BIOTA	DILUTION=	1.00E+00	TRANSIT TIME=	0.00E+00 HR
	INTERNAL	EXTERNAL	TOTAL	
FISH	3.82E+00	5.84E+00	9.66E+00	
INVERTEBRATE	1.92E+00	1.17E+01	1.36E+01	
ALGAE	9.65E-01	3.58E-03	9.69E-01	
MUSKRAT	2.07E+01	3.89E+00	2.46E+01	
RACCOON	7.73E+00	2.92E+00	1.07E+01	
HERON	1.21E+02	3.89E+00	1.25E+02	
DUCK	1.89E+01	5.84E+00	2.48E+01	

SECTION VI

RADIOACTIVE EFFLUENT RELEASES - SOLID RADIOACTIVE WASTE

January 1, 2020 - December 31, 2020

VI. RADIOACTIVE EFFLUENT RELEASE – SOLID RADIOACTIVE
WASTE EFFLUENT AND WASTE DISPOSAL REPORT

January 1, 2020 through December 31, 2020

A. Resins, Filters, and Evaporator Bottoms

Waste Class	Volume		Curies Shipped
	ft ³	m ³	
A	0.0	0.0	0.0
B	0.0	0.0	0.0
C	0.0	0.0	0.0
Unclassified	0.0	0.0	0.0
ALL	0.0	0.0	0.0
Major Nuclides for the Above Table:			
N/A			

B. Dry Active Waste

Waste Class	Volume		Curies Shipped
	ft ³	m ³	
A	1.43E+04	4.06E+02	7.66E-01
B	0.0	0.0	0.0
C	0.0	0.0	0.0
Unclassified	0.0	0.0	0.0
ALL	1.43E+04	4.06E+02	7.66E-01
Major Nuclides for the Above Table:			
H-3, C-14, Co-60, Fe-55, Ni-63, Sr-90, Tc-99, I-129, Cs-137, Pu-238, Pu-239, Pu-241, Am-241, Cm-243, Cm-244			

C. Irradiated Components

Waste Class	Volume		Curies Shipped
	ft ³	m ³	
A	0.0	0.0	0.0
B	0.0	0.0	0.0
C	0.0	0.0	0.0
Unclassified	0.0	0.0	0.0
ALL	0.0	0.0	0.0
Major Nuclides for the Above Table:			
N/A			

VI. RADIOACTIVE EFFLUENT RELEASE – SOLID RADIOACTIVE
WASTE EFFLUENT AND WASTE DISPOSAL REPORT
(Continued)

D. Other Waste

Waste Class	Volume		Curies Shipped
	ft ³	m ³	
A	1.55E+04	4.39E+02	3.37E+01
B	0.0	0.0	0.0
C	0.0	0.0	0.0
Unclassified	0.0	0.0	0.0
ALL	1.55E+04	4.39E+02	3.37E+01
Major Nuclides for the Above Table:			
H-3, C-14, Co-60, Fe-55, Ni-63, Sr-90, Tc-99, I-129, Cs-137, Pu-238, Pu-239, Pu-241, Am-241, Cm-242, Cm-243			

E. Sum of All Low-Level Waste Shipped from Site

Waste Class	Volume		Curies Shipped
	ft ³	m ³	
A	2.98E+04	8.45E+02	3.44E+01
B	0.0	0.0	0.0
C	0.0	0.0	0.0
Unclassified	0.0	0.0	0.0
ALL	2.98E+04	8.45E+02	3.44E+01
Major Nuclides for the Above Table:			
H-3, C-14, Co-60, Fe-55, Ni-63, Sr-90, Tc-99, I-129, Cs-137, Pu-238, Pu-239, Pu-241, Am-241, Cm-242, Cm-243, Cm-244			

SECTION VII

ATTACHMENT 1

The Annual Radioactive Effluent Release Report shall include any revisions to the Offsite Dose Calculation Manual (ODCM) and the Process Control Program (PCP) for the period January 1, 2020 through December 31, 2020.

 2 revisions were made to the Offsite Dose Calculation Manual (ODCM).

 1 revision was made to the Process Control Program (PCP).

January 1, 2020 - December 31, 2020

CH-ODCM-0001

Off-Site Dose Calculation Manual (ODCM)

Revision 32

Safety Classification:

Non-Safety

Usage Level:

Reference

Change No.:	EC 70292
Reason for Change:	ISFSI Only Tech Spec
Preparer:	J. Hoffman

Fort Calhoun Station

Table of Contents

PART I

1.0	PURPOSE AND SCOPE	6
1.1	Purpose	6
1.2	Scope	6
2.0	DEFINITIONS	6
3.0	INSTRUMENTATION	10
3.1	Radioactive Liquid Effluent Instrumentation	10
3.2	Radioactive Gaseous Effluent Instrumentation	13
4.0	RADIOACTIVE EFFLUENTS	17
4.1	Radioactive Liquid Effluents	17
4.2	Radioactive Gaseous Effluents	23
4.3	Uranium Fuel Cycle	29
5.0	RADIOLOGICAL ENVIRONMENTAL MONITORING PROGRAM (REMP)	30
5.1	Monitoring Program	30
5.2	Land Use Survey	45
5.3	Interlaboratory Comparison Program	46
6.0	ADMINISTRATIVE CONTROLS	47
6.1	Responsibilities	47
6.2	Radioactive Effluent Reporting Requirements	47
6.3	Change Mechanism	52
6.4	Meteorological Data	52
6.5	References	53
7.0	BASIS	55
7.1	Instrumentation	55
7.2	Radioactive Effluents	55
7.3	Radiological Environmental Monitoring	60
7.4	Abnormal Release or Abnormal Discharge Reporting	61

**List of Tables
PART I**

Table 1.2 - Frequency Notation	8
Table 1.3 - Radiological Effluent Controls Program Technical Specification Implementation..	9
Table 3.1.1 - Radioactive Liquid Effluent Monitoring Instrumentation.....	11
Table 3.1.2 - Radioactive Liquid Effluent Monitoring Instrumentation Surveillance Requirements.....	12
Table 3.2.1 - Radioactive Gaseous Effluent Monitoring Instrumentation	14
Table 3.2.2 - Radioactive Gaseous Effluent Monitoring Instrumentation Surveillance Requirements	16
Table 4.1 - Radioactive Liquid Effluent Sampling and Analysis.....	19
Table 4.2 - Radioactive Airborne Effluent Sampling and Analysis	24
Table 4.3 - Sampler Deposition/Transportation Correction Factors.....	26
Table 5.1 - Radiological Environmental Monitoring Program.....	32
Table 5.2 - Radiological Environmental Sampling Locations And Media.....	35
Table 5.3 - Detection Capabilities for Environmental Sample Analysis Lower Limit of Detection (LLD)	43
Table 5.4 - Reporting Levels for Radioactivity Concentrations in Environmental Samples	44

**List of Figures
PART I**

Figure 1 – Environmental Radiological Sampling Points	41
Figure 2 – 40CFR190 Sampling Points	42

Table of Contents

PART II

1.0	EFFLUENT MONITOR SETPOINTS.....	64
1.1	Liquid Effluents.....	64
1.2	Airborne Effluents.....	67
2.0	EFFLUENT CONCENTRATIONS	75
2.1	Liquid Effluent Concentrations	75
2.2	Airborne Effluent Concentrations	75
3.0	RADIOACTIVE EFFLUENT DOSE CALCULATIONS	77
3.1	Liquid Effluent Dose Calculations.....	77
3.2	Airborne Effluent Dose Calculations.....	80
4.0	LOWER LIMIT OF DETECTION (LLD).....	93

**List of Tables
PART II**

Table 1 - Deleted	67
Table 2 - Deleted	94
Table 3 - Bioaccumulation Factors	94
Table 4 - Highest Potential Exposure Pathways for Estimating Dose.....	95
Table 5 - Stable Element Transfer Data	96
Table 6 - Recommended Values for U_{ap} to Be Used for the Maximum Exposed Individual in Lieu of Site Specific Data.....	97
Table 7 - Animal Consumption Rates	97
Table 8 - External Dose Factors for Standing on Contaminated Ground.....	98
Table 9 - Inhalation Dose Factors for Adult	101
Table 10 - Inhalation Dose Factors for Teenager	104
Table 11 - Inhalation Dose Factors for Child	107
Table 12 - Inhalation Dose Factors for Infant	110
Table 13 - Ingestion Dose Factors for Adult	113
Table 14 - Ingestion Dose Factors for Teenager	116
Table 15 - Ingestion Dose Factors for Child	119
Table 16 - Ingestion Dose Factors for Infant	122
Table 17 - Recommended Values for Other Parameters.....	125
Table 18 - Estimated Doses Received by the General Public from On-Site Exposure....	Error!

Bookmark not defined.**List of Figures
PART II**

Figure 1 - Exclusion and Site Boundary Map	68
Figure 2 - Liquid Radioactive Discharge Pathways	69
Figure 3 - Liquid Radioactive Waste Disposal System	70
Figure 4 - Airborne Effluent Discharge Pathways	71
Figure 5 - Airborne Radioactive Waste Disposal System	72

1.0 PURPOSE AND SCOPE

1.1 Purpose

1.1.1 Contains methodologies for and parameters necessary for calculating offsite doses, determination of gaseous and liquid radiation monitor set points, and administrative controls for effluent instrumentation, Radiological Effluent Tech Specs (RETS), and the Radiological Environmental Monitoring Program (REMP).

1.2 Scope

1.2.1 Radioactive effluents are generated from station activities. These controls provide methodologies ensuring these effluents are properly monitored and quantified to promote accurate dose reporting. Additional controls ensure station equipment and processes are used to minimize release to the environment. The combination of minimizing release, accurately reporting dose, and monitoring the facility environs provides the basis for ensuring that station activities are not negatively impacting public health and the environment.

2.0 DEFINITIONS

2.1 Abnormal Discharge - The unplanned or uncontrolled emission of an effluent (i.e., containing facility-related, licensed radioactive material) into the unrestricted area.

2.2 Abnormal Release - The unplanned or uncontrolled emission of an effluent (i.e., containing facility-related, licensed radioactive material).

2.3 Channel Check - A CHANNEL CHECK shall be the qualitative assessment of channel behavior during operation by observation. This determination shall include, where possible, comparison of the channel indication and/or status with other indications and/or status derived from independent instrument channels measuring the same parameter.

2.4 Channel Function Test - Injection of a simulated signal into the channel to verify that it is functional, including any alarm and/or trip initiating action.

2.5 Effluent Concentration Limit (ECL) - Radionuclide limits listed in 10 CFR Part 20, Appendix B, Table 2, Column 1.

2.6 Member(s) of the Public - Member(s) of the Public means any individual except when that individual is receiving occupational dose.

- 2.7 Functional-Functionality - A system, subsystem, train, component or device shall be FUNCTIONAL or have FUNCTIONALITY when it is capable of performing its specified function(s) and when all necessary attendant instrumentation, controls, normal or emergency electrical power sources, cooling and seal water, lubrication, and other auxiliary equipment that are required for the system, subsystem, train, component, or device to perform its function(s) are also capable of performing their related support function(s).
- 2.8 Residual Radioactivity - Residual radioactivity means radioactivity in structures, materials, soils, ground water, and other media at a site resulting from activities under the licensee's control. This includes radioactivity from all licensed and unlicensed sources used by the licensee, but it excludes background radiation. It also includes radioactive materials remaining at the site as a result of routine or accidental releases of radioactive material at the site and previous burials at the site, even if those burials were made in accordance with the provisions of 10 CFR Part 20.
- 2.9 Site Boundary - The Site Boundary is the line beyond which the land is neither owned, or leased, nor controlled by the licensee.
- 2.10 Source Check - A SOURCE CHECK shall be the qualitative assessment of channel response when the channel sensor is exposed to a source of increased radioactivity.
- 2.11 Special Liquid - Non-routine release pathway in which normally non-radioactive liquid streams (such as Raw Water) found to contain radioactive material, are non-routine, and will be treated on a case specific basis if and when this occurs.
- 2.12 Unrestricted Area - An UNRESTRICTED AREA shall be any area at or beyond the SITE BOUNDARY access to which is not controlled by the licensee for purposes of protection of individuals from exposure to radiation and radioactive materials, or any area within the SITE BOUNDARY used for residential quarters or for industrial, commercial, institutional, and/or recreational purposes.
- 2.13 Venting - VENTING shall be the controlled process of discharging air or gas from a confinement to maintain temperature, pressure, humidity, concentration, or other operating condition, in such a manner that replacement air or gas is not provided or required during VENTING. Vent, used in system names, does not imply a VENTING process.
- 2.14 Water Effluent Concentration (WEC) - Radionuclide limits listed in 10 CFR Part 20, Appendix B, Table 2, Column 2.

Table 1.2 - Frequency Notation

The surveillance intervals are defined as follows:

Notation	Title	Frequency^A
S	Shift	At least once per 12 hours
D	Daily	At least once per 24 hours
W	Weekly	At least once per 7 days
BW	Biweekly	At least once per 14 days
M	Monthly	At least once per 31 days
Q	Quarterly	At least once per 92 days
SA	Semiannual	At least once per 184 days
A	Annually	At least once per 366 days
R		At least once per 18 months
P	Prior to	Prior to each release (Performance within 24 hrs.)

- A. Each surveillance requirement shall be performed within the specified surveillance interval with a maximum allowable extension not to exceed 25 percent of the specified surveillance interval.

Table 1.3 - Radiological Effluent Controls Program Implementation

NO-FC-10 Appendix E	ODCM Implementing Step
E.2.1.3.a	3.1.1, 3.2.1
E.2.1.3.b	4.1.1
E.2.1.3.c	Table 4.1, Table 4.2
E.2.1.3.d	4.1.2
E.2.1.3.e	4.1.2B.1, 4.2.2B.1
E.2.1.3.f	4.1.3A, 4.2.4A
E.2.1.3.g	4.2.2
E.2.1.3.h	4.2.3
E.2.1.3.i	4.3.1
E.3.1.3.a	5.1.1
E.3.1.3.b	5.2.1
E.3.1.3.c	5.3.1
E.1.2	6.3, 6.2.1D
E.4.1	6.2.1
E.4.2	6.2.2

3.0 **INSTRUMENTATION**

3.1 Radioactive Liquid Effluent Instrumentation

3.1.1 Limiting Condition for Operation

- A. The radioactive liquid effluent monitoring instrumentation channels shown in Table 3.1.1 shall be FUNCTIONAL with their alarm/trip setpoints set to ensure that the limits of Specification 3.1.1 are not exceeded. The alarm/trip setpoints of these channels shall be determined in accordance with Part II of the Off-Site Dose Calculation Manual.

APPLICABILITY: At all times

ACTION:

1. With a radioactive liquid effluent monitoring instrumentation channel alarm/trip setpoint less conservative than required by the above specification, immediately suspend the releases of radioactive liquid effluents monitored by the affected channel or declare the channel non-functional.
2. With less than the minimum number of radioactive liquid effluent monitoring instrumentation channels functional, take the action shown in Table 3.1.1. Restore non-functional effluent monitoring instrumentation to FUNCTIONAL status within 30 days and, if unsuccessful, explain in the next Annual Radiological Effluent Release Report why this non-functionality was not corrected in a timely manner. The reporting requirement is limited to the following instrumentation that monitors effluent stream: RM-055.

3.1.2 Surveillance Requirements

- A. Each radioactive liquid effluent monitoring instrumentation channel shall be demonstrated FUNCTIONAL by performance of the CHANNEL CHECK, SOURCE CHECK, CALIBRATION, and CHANNEL FUNCTIONAL TEST at the frequencies shown in Table 3.1.2.

Table 3.1.1 - Radioactive Liquid Effluent Monitoring Instrumentation

Instrument		Minimum Channels Functional	Action
1.	Radioactivity Monitor Providing Alarm and Automatic Termination of Release.		
1.1	Liquid Radwaste Effluent Line (RM-055)	1	1, 4
2.	Flow Rate Measurement Device		
2.1	Liquid Radwaste Effluent Line	1	2
3.	Radioactivity Recorder		
3.1	Liquid Radwaste Effluent Line	1	3

Table Notation

ACTION 1	With the number of channels FUNCTIONAL less than required by the Minimum Channels FUNCTIONAL requirement, effluent releases may continue provided that prior to initiating a release: <ol style="list-style-type: none"> At least two independent samples are analyzed in accordance with applicable chemistry procedures. At least two qualified individuals independently verify the release rate calculations.
ACTION 2	With the number of channels FUNCTIONAL less than required by the Minimum Channels FUNCTIONAL requirement, effluent releases may continue provided the flow rate is determined at least once per four hours during the actual release.
ACTION 3	With the number of channels FUNCTIONAL less than required by the Minimum Channels FUNCTIONAL requirement, effluent releases may continue provided the radioactivity is recorded manually at least once per four hours during the actual release.
ACTION 4	During the performance of source checks the effluent radiation monitor is unable to respond, hence is considered non-functional. Effluent releases may continue uninterrupted during the performance of source checks provided the operator is stationed at the monitor during the check. If the effluent radiation monitor fails the source check, carryout the action(s) of the Off-Site Dose Calculation Manual for the non-functional monitor or terminate the effluent release.

Table 3.1.2 - Radioactive Liquid Effluent Monitoring Instrumentation Surveillance Requirements

Instrument	Channel Check	Channel		Source Check
		Calibration	Function Test	
1. Radioactivity Monitor Providing Alarm and Automatic Isolation				
1.1 RM-055	----	R	Q	P

3.2 Radioactive Gaseous Effluent Instrumentation

3.2.1 Limiting Condition for Operation

- A. The radioactive gaseous effluent monitoring instrumentation channels shown in Table 3.2.1 shall be FUNCTIONAL to ensure that the limits of Specification 3.2.1 are not exceeded.

APPLICABILITY: At all times

ACTION:

1. With less than the minimum number of radioactive gaseous effluent monitoring instrumentation channels functional, take the action shown in Table 3.2.1. Restore non-functional effluent monitoring instrumentation to FUNCTIONAL status within 30 days and, if unsuccessful, explain in the next Annual Radiological Effluent Release Report why this non-functionality was not corrected in a timely manner. The reporting requirement is limited to the following instrumentation that monitors effluent streams: RM-043, RM-062, RM-052 and Particulate Air Samplers.

3.2.2 Surveillance Requirements

- A. Each radioactive gaseous effluent monitoring instrumentation channel shall be demonstrated FUNCTIONAL by performance of the CHANNEL CHECK, CALIBRATION, and CHANNEL FUNCTIONAL TEST at the frequencies shown in Table 3.2.2.

Table 3.2.1 - Radioactive Gaseous Effluent Monitoring Instrumentation

Instrument		Minimum Channels Functional	Action
1.	Forced Draft releases		
1.1	Particulate-Auxiliary Bldg. Exhaust Stack (RM-052, RM-062)	1	1,4
1.2	Particulate-Laboratory and Radwaste Processing Building Stack (RM-043)	1	2
1.3	Particulate air sampler-Portable filtered ventilation systems discharge	1	5
2.	Unventilated building opening		
2.1	Particulate air sampler-open doorway/ open rollup door	1	6
3.	Open-air demolition		
3.1	Particulate air samplers (4 air samplers at each open-air location)	4	7
4.	Flow Rate Measurement Devices		
4.1	Auxiliary Building Exhaust Stack	1	3
4.2	Laboratory and Radwaste Processing Building Stack	1	3
4.3	Hand-held anemometer	1	3

Table 3.2.1 Radioactive Gaseous Effluent Monitoring Instrumentation

Table Notation	
ACTION 1	If the Auxiliary Building Exhaust Stack Particulate Sampler is non-functional, ventilation of the Auxiliary Building may continue through the Auxiliary Building Exhaust Stack provided sample collection in accordance with Table 4.2 using auxiliary sample collection equipment is initiated within 2 hours of the declaration of non-functionality by the ISFSI Shift Supervisor (ISS).
ACTION 2	If the Particulate Sampler is non-functional, ventilation of the LRWPB may continue via the LRWPB Stack provided sample collection using auxiliary sample collection equipment is initiated within 2 hours of the declaration of non-functionality, by the ISFSI Shift Supervisor (ISS), in accordance with Table 4.2.
ACTION 3	With the number of channels FUNCTIONAL less than required by the Minimum Channels FUNCTIONAL requirement, effluent releases may continue provided the flowrate is estimated or recorded manually at least once per four hours during the actual release.
ACTION 4	During the ventilation of airborne effluents from the Auxiliary Building Exhaust Stack at least one Auxiliary Building Exhaust fan shall be in operation.
ACTION 5	If portable air sampler monitoring the discharged of a portable filtered ventilation unit OR its associated flowmeter is non-functional, active decommissioning may continue provided the portable air sampler is replaced within 2 hours of declaration of non-functionality. If air sampler is unable to be replaced within 2 hours, secure the release fan AND cease active decommissioning in the area monitored by the non-functioning air sampler.
ACTION 6	If portable air sampler monitoring open doorways in unventilated building flowpaths OR its associated flowmeter is non-functional, active decommissioning may continue provided the portable air sampler is replaced within 2 hours of declaration of non-functionality. If air sampler is unable to be replaced within 2 hours, close the door associated with this air sampler OR cease active decommissioning work until the air sampler can be replaced.
ACTION 7	If any of the 4 air samplers monitoring air around an open-air demolition location OR their associated flowmeters are non-functional, active decommissioning may continue provided the portable air sampler is replaced within 2 hours of declaration of non-functionality. If the open-air demolition location is unable to be monitored by 4 air samplers, cease active open-air decommissioning at the affected location.

Table 3.2.2 - Radioactive Gaseous Effluent Monitoring Instrumentation
Surveillance Requirements

Instrument		Channel Check	Calibration	Channel Function Test	Source Check
1.	Flowrate Monitors				
1.1	RM-043 Sampler	D	R	Q	----
1.2	RM-062 Sampler	D	R	Q	----
1.3	RM-052 Sampler	D	R	Q	----
1.4	Auxiliary Bldg Exhaust Stack	D	R	Q	----
1.5	Laboratory and Radwaste Process Bldg Exhaust Stack	D	R	Q	----
		Operations Check		Air Flow Calibration	
2.	Environmental Monitors				
2.1	RM-023 - Sample Station #40		M		A
2.2	RM-024 - Sample Station #41		M		A
2.3	RM-025 - Sample Station #28		----		----
2.4	RM-026 - Sample Station #36		----		----
2.5	RM-027 - Sample Station #37		M		A
2.6	RM-028 - Sample Station #38		----		----
2.7	RM-029 - Sample Station #39		----		----
2.8	RM-035 - Sample Station #1		----		----
2.9	RM-036 - Sample Station #2		M		A
2.10	RM-037 - Sample Station #3		----		----
2.11	RM-038 - Sample Station #4		M		A
2.12	RM-039 - Sample Station #5		----		----
2.13	RM-040 - Sample Station #32		M		A
3.	Decommissioning portable air sampler flowmeters				
3.1	All sample stations		W ¹		A

1- Operation check performed only when the unit is started to support active decommissioning.

4.0 **RADIOACTIVE EFFLUENTS**

4.1 Radioactive Liquid Effluents

4.1.1 Concentration

A. Limiting Condition for Operation

1. The release rate of radioactive material in liquid effluents shall be controlled such that the instantaneous concentrations for radionuclides do not exceed the values specified in 10 CFR Part 20 for liquid effluents at site discharge. To support facility operations, RP/Chemistry supervision may increase this limit up to the limit specified in QATR Appendix E, E.2.1.3.b.
2. QATR Appendix E, E.2.1.3.b establishes the administrative control limit on concentration of radioactive material, other than dissolved or entrained noble gases, released in liquid effluents to unrestricted areas conforming to ten times 10 CFR Part 20.1001-20.2401, Appendix B, Table 2, Column 2.

APPLICABILITY: At all times

ACTION:

- a. When the concentration of radioactive material released at site discharge exceeds the above limits, appropriate corrective actions shall be taken immediately to restore concentrations within the above limits.

B. Surveillance Requirements

i	<u>NOTE</u>	i
	Radioactive liquid waste includes water used for fire suppression in areas of the facility that may contain radioactivity. These liquids are required to be monitored prior to release.	

1. Radioactive liquid waste shall be sampled and analyzed according to the sampling and analysis program in Table 4.1.
2. The results of the radioactivity analysis shall be used with the calculational methods in Part II of the Off-Site Dose Calculation Manual.
3. To assure that the concentration at the point of release is maintained within the limits of QATR Appendix E, E.2.1.3.b.
4. Records shall be maintained of the radioactive concentrations and volume before dilution of each batch of liquid effluent released and of the average dilution flow and length of time over which each discharge occurred. Analytical results shall be submitted to the Commission in accordance with Part I, Section 6.0 of the Off-Site Dose Calculation Manual.

Table 4.1 - Radioactive Liquid Effluent Sampling and Analysis

A. Monitor, Hotel Waste Tanks & Special Liquid, Releases

Sampling Frequency	Type of Activity Analysis	Lower Limit of Detection (LLD) ($\mu\text{Ci/ml}$) ^A
Each Batch	Principal Gamma Emitters ^B	5.0E-07
Monthly Composite ^C	H-3	1.0E-05
Monthly Composite ^C	Gross Alpha	1.0E-07
Quarterly Composite ^C	Sr-89, Sr-90	5.0E-08
Quarterly Composite ^C	Fe-55, Ni-63	1.0E-06

NOTES:

- A. LLD is defined in Part II of the Off-Site Dose Calculation Manual.
- B. The principal gamma emitters for which the LLD specification applies exclusively are the following radionuclides: Mn-54, Fe-59, Co-58, Co-60, Zn-65, Mo-99, Cs-134, Cs-137, and Ce-141 for fission and corrosion products. Ce-144 shall also be measured, but with a LLD of 5.0E-06.
- C. To be representative of the average quantities and concentrations of radioactive materials in liquid effluents, samples should be collected in proportion to the rate of flow of the effluent stream. Prior to analyses, all samples taken for the composite should be mixed in order for the composite sample to be representative of the average effluent release.

4.1.2 Dose from Radioactive Liquid Effluents

A. Limiting Condition for Operation

1. The dose or dose commitment to an individual in unrestricted areas from radioactive materials in liquid effluents shall be limited to the following:
 - a. During any calendar quarter: Less than or equal to 1.5 mrem to the total body and 5 mrem to any organ; and
 - b. During any calendar year: Less than or equal to 3 mrem to the total body and 10 mrem to any organ.

APPLICABILITY: At all times

ACTION:

- a. If the dose contribution, due to the cumulative release of radioactive materials in liquid effluents, exceeds the annual or quarterly dose objectives, submit a Special Report to the NRC, per Section 6.2.4, within 30 days.

B. Surveillance Requirements

1. Cumulative dose contributions from liquid effluents for the current calendar quarter and the current calendar year shall be determined in accordance with the methodology and parameters in Part II of the Off-Site Dose Calculation Manual at least once per quarter.

4.1.3 Liquid Radwaste Treatment

A. Limiting Condition for Operation

1. The Liquid Radwaste Treatment System shall be FUNCTIONAL, and appropriate portions of these systems shall be used to reduce releases of radioactivity when the projected doses due to the liquid effluent, from each unit, to UNRESTRICTED AREAS would exceed 0.06 mrem to the whole body or 0.2 mrem to any organ in a 31-day period.

APPLICABILITY: At all times

ACTION:

- a. With radioactive liquid waste being discharged without treatment and in excess of the above limits and any portion of the Liquid Radwaste Treatment System not in operation, prepare and submit to the Nuclear Regulatory Commission within 30 days, pursuant to 10 CFR 50, Appendix I, a Special Report that includes the following information:
 - 1) Explanation of why liquid radwaste was being discharged without treatment, identification of equipment or subsystem(s) not functional and reasons for non-functionality.
 - 2) Action(s) taken to restore the non-functional equipment to functional status.
 - 3) Summary description of action(s) taken to prevent a recurrence.

B. Surveillance Requirements

1. Dose due to liquid releases shall be projected frequently and at least once per quarter, in accordance with the methodology and parameters in Part II of the Off-Site Dose Calculation Manual, when Liquid Radwaste Treatment Systems are not fully FUNCTIONAL.
2. FUNCTIONAL is defined as follows:
 - a. A filtration/ion exchange (FIX) system will be utilized for processing liquid radwaste. The system consists of a booster pump, charcoal pretreatment filter, and pressure vessels containing organic/inorganic resins, which can be configured for optimum performance. The effluent from the FIX system is directed to the monitor tanks for release.

4.1.3B.2 (continued)

- b. Waste filters (WD-17A and WD-17B) are used only on those occasions when considered necessary, otherwise the flows from the low activity fluids may bypass the filters. No credit for decontamination factors (iodines, Cs, Rb, others) was taken for these filters during the 10 CFR Part 50 Appendix I dose design objective evaluation; therefore, the non-functionality of these filters does not affect the dose contributions to any individual in the unrestricted areas via liquid pathways. The non-functionality of waste filters will not be considered a reportable event in accordance with the Action listed above.

4.1.4 Liquid Holdup Tanks

Tanks included in this Specification are those outdoor tanks that are not surrounded by liners, dikes, or walls capable of holding the tanks contents and that do not have tank overflows and surrounding area drains connected to the liquid radwaste treatment system.

A. Limiting Condition for Operation

1. The quantity of radioactive material contained in each unprotected outdoor liquid holdup tank shall not exceed 10 curies, excluding tritium and dissolved or entrained noble gases.

APPLICABILITY: At all times

ACTION:

- a. When the quantity of radioactive material in any unprotected outdoor liquid holdup tank exceeds 10 curies, excluding tritium and dissolved or entrained noble gasses, immediately suspend all additions of radioactive material to the tank and within 48 hours reduce the tank contents to within the limit.

B. Surveillance Requirements

1. The quantity of radioactive material contained in each outdoor liquid holdup tank shall be determined to be within the above limit by analyzing a representative sample of the tanks contents at least once per 7 days when radioactive material is being added to the tank.

4.2 Radioactive Gaseous Effluents

4.2.1 Concentration

A. Limiting Condition for Operation

1. The release rate of radioactive material in airborne effluents shall be controlled such that the instantaneous concentrations of radionuclides does not exceed the values specified in 10 CFR Part 20 for airborne effluents at the unrestricted area boundary.

APPLICABILITY: At all times

ACTION:

- a. When the concentration of radioactive material released to unrestricted areas exceeds the above limits, appropriate corrective actions shall be taken immediately to restore concentrations within the above limits.

B. Surveillance Requirements

i	<u>NOTE</u>	i
	Radioactive gaseous wastes include atmospheres in areas where gaseous fire suppression systems are utilized or where smoke is produced as a result of fire in areas of the facility that may contain radioactivity. These atmospheres are required to be monitored prior to gaseous release to unrestricted areas.	

1. Radioactive gaseous wastes shall be sampled and analyzed according to the sampling and analysis program of Table 4.2. The results of the radioactivity analysis shall be used to assure the limits in Step 4.2.1A are not exceeded.

Table 4.2 - Radioactive Airborne Effluent Sampling and Analysis

A. Auxiliary Building Exhaust Stack ^D

Sampling Frequency	Type of Activity Analysis	Lower Limit of Detection (LLD) ($\mu\text{Ci/ml}$) ^A
Weekly (Particulate Sample)	Principal Gamma Emitters ^B	1.0E-11
Weekly	Tritium (H-3)	1.0E-06
Monthly Composite ^C	Gross Alpha	1.0E-11
Quarterly Composite (Particulate Samples)	Sr-89, Sr-90	1.0E-11

B. Laboratory and Radwaste Building Exhaust Stack ^D

Sampling Frequency	Type of Activity Analysis	Lower Limit of Detection (LLD) ($\mu\text{Ci/ml}$) ^A
Weekly (Particulate Sample)	Principal Gamma Emitters ^B	1.0E-11
Monthly Composite ^C	Gross Alpha	1.0E-11
Quarterly Composite (Particulate Sample)	Sr-89, Sr-90	1.0E-11

C. Forced Draft Exhaust discharge

Sampling Frequency	Type of Activity Analysis	Lower Limit of Detection (LLD) ($\mu\text{Ci/ml}$) ^A
Weekly (Particulate Sample)	Principal Gamma Emitters ^B	1.0E-11
Monthly Composite ^C	Gross Alpha	1.0E-11
Quarterly Composite (Particulate Sample)	Sr-90	1.0E-11

D. Unventilated building doorways

Sampling Frequency	Type of Activity Analysis	Lower Limit of Detection (LLD) ($\mu\text{Ci/ml}$) ^A
Weekly (Particulate Sample)	Principal Gamma Emitters ^B	1.0E-11
Monthly Composite ^C	Gross Alpha	1.0E-11
Quarterly Composite (Particulate Sample)	Sr-90	1.0E-11

E. Open-Air Demolition locations

Sampling Frequency	Type of Activity Analysis	Lower Limit of Detection (LLD) ($\mu\text{Ci/ml}$)^A
Weekly (Particulate Sample)	Principal Gamma Emitters ^B	1.0E-11
Monthly Composite ^C	Gross Alpha	1.0E-11
Quarterly Composite (Particulate Sample)	Sr-90	1.0E-11

NOTES:

- A. LLD is defined in Part II of the Off-Site Dose Calculation Manual.
- B. The principal gamma emitters for which the LLD specification applies exclusively are the following radionuclides: Mn-54, Fe-59, Co-58, Co-60, Zn-65, Mo-99, Cs-134, Cs-137, Ce-141, and Ce-144 for particulate releases.
- C. Frequency requirement may be satisfied using weekly gross alpha results from particulate sampling media.
- D. Particulate samples shall be corrected for sampler deposition/transportation efficiency by using the approved software programs or by multiplying the activity obtained by the associated sampler multiplication factor (See Table 4.3).

Table 4.3 - Sampler Deposition/Transportation Correction Factors

Sampler	Sample	Particulate	
		DF	ACTMULT
RM-062	AB	0.411	2.433
RM-052	AB	0.638	1.567
RM-043	LRWPB	0.809	1.236
Portable Air Sampler	Forced Draft, Unventilated Building, Open-Air	1.00	1.00

ACRONYM DEFINITIONS:

AB - Auxiliary Building Exhaust Stack

LRWPB - Laboratory and Rad Waste Processing Building

DF - Deposition Factor

ACTMULT - Activity multiplication factor to correct for sample loss.

4.2.2 Dose - H-3 and Radioactive Material in Particulate Form with Half-Lives Greater than 8 Days (Other than Noble Gases)

A. Limiting Condition for Operation

1. The dose to an individual or dose commitment to any organ of an individual in unrestricted areas due to the release of H-3 and radioactive materials in particulate form with half-lives greater than eight days (excluding noble gases) in airborne effluents shall be limited to the following:
 - a. During any calendar quarter: Less than or equal to 7.5 mrem to any organ; and
 - b. During any calendar year: Less than or equal to 15 mrem to any organ.

APPLICABILITY: At all times

ACTION:

- a. If the dose contribution, due to the cumulative release of H-3 and radioactive materials in particulate form with half-lives greater than eight days, exceeds the annual or quarterly dose objectives, submit a Special Report to the NRC per Section 6.2.4, within 30 days.

B. Surveillance Requirements

1. The radiation dose contributions from H-3 and radioactive materials in particulate form with half-lives greater than eight days (excluding noble gases) in airborne effluents shall be determined, in accordance with the methodologies and parameters of Part II of the Off-Site Dose Calculation Manual, on a quarterly basis.

4.2.3 Gaseous Radwaste Treatment

A. Limiting Condition for Operation

1. In accordance with QATR Appendix E, E.2.1.3.f, the Ventilation Exhaust Systems shall be FUNCTIONAL, and appropriate portions of these systems shall be used to reduce the releases of radioactivity when the projected doses in 31 days due to gaseous effluent releases to areas at and beyond the SITE BOUNDARY would exceed:
 - a. 0.2 mrad to air from gamma radiation, or

- b. 0.4 mrad to air from beta radiation, or
- c. 0.3 mrem to any organ of a MEMBER OF THE PUBLIC

APPLICABILITY: At all times

ACTION:

- a. With radioactive gaseous waste being discharged without treatment and in excess of the above limits, prepare and submit a report to the Nuclear Regulatory Commission within 30 days, pursuant to 10 CFR 50, Appendix I, a special report that includes the following information:
 - 1) Identification of equipment or subsystem(s) not functional and reasons for non-functionality.
 - 2) Action(s) taken to restore the non-functional equipment to functional status.
 - 3) Summary description of action(s) taken to prevent a recurrence.

B. Surveillance Requirements

- 1. Dose due to gaseous releases shall be projected frequently and at least once per quarter, in accordance with the methodology and parameters in Part II of the Off-Site Dose Calculation Manual, when Ventilation Exhaust Systems are not fully FUNCTIONAL.
- 2. FUNCTIONAL is defined as follows:
 - a. Ventilation Exhaust Systems
 - 1) The radioactive effluents from the controlled access area of the auxiliary building are filtered by the HEPA filters in the auxiliary building ventilation system. If the radioactive effluents are discharged without the HEPA filters and it is confirmed that one half of the annual dose objective will be exceeded during the calendar quarter, a special report shall be submitted to the Commission pursuant to Section 4.2.3A.

4.3 Uranium Fuel Cycle

4.3.1 Total Dose-Uranium Fuel Cycle

A. Limiting Condition for Operation

1. The dose to any real individual from uranium fuel cycle sources shall be limited to ≤ 25 mrem to the total body or any organ (except the thyroid, which shall be limited to ≤ 75 mrem) during each calendar year.

APPLICABILITY: At all times

ACTION:

- a. With the calculated dose from the release of radioactive materials in liquid or gaseous effluents exceeding twice the limits of specifications 4.1.2A, or 4.2.2A, calculations shall be made including direct radiation contribution from the facility and outside storage tanks to determine whether the above limits have been exceeded. If such is the case, in lieu of any other report required by Section 6.2, prepare and submit a Special Report to the Commission pursuant to QATR Appendix E, E.2.1 that defines the corrective action to be taken to reduce subsequent releases to prevent recurrence of exceeding the above limits and includes the schedule for achieving conformance with the above limits. This Special Report, as defined in 10 CFR Part 20.2203(a)(4) and 20.2203(b), shall include an analysis that estimates the radiation exposure (dose) to a MEMBER OF THE PUBLIC from uranium fuel cycle sources, including all effluent pathways and direct radiation, for the calendar year that includes the release(s) covered by this report. It shall also describe levels of radiation and concentration of radioactive material involved, and the cause of exposure levels or concentrations. If the estimated dose(s) exceeds the above limits, and if the release condition resulting in the violation of 40 CFR Part 190 or 10 CFR Part 72.104 has not already been corrected, the Special Report shall include a request for a variance in accordance with the provisions of 40 CFR Part 190 or 10 CFR Part 72.104. Submittal of the report is considered a timely request, and a variance is granted until staff action on the request is complete.

4.3.1 (continued)

B. Surveillance Requirements

1. Cumulative dose contributions from liquid and gaseous effluents shall be determined in accordance with surveillance requirements 4.1.2B and 4.2.2B and in accordance with the methodology and parameters in Part II of the Off-Site Dose Calculation Manual.

5.0 RADIOLOGICAL ENVIRONMENTAL MONITORING PROGRAM (REMP)

5.1 Monitoring Program

5.1.1 Limiting Condition for Operation

- A. The Radiological Environmental Monitoring Program shall be conducted as specified in Table 5.1.

APPLICABILITY: At all times

ACTION:

1. Analytical results of this program and deviations from the sampling schedule shall be reported to the Nuclear Regulatory Commission in the Annual Radiological Environmental Operating Report (Section 6.2).
2. If the level of radioactivity from calculated doses leads to a higher exposure pathway to individuals, this pathway shall be added to the Radiological Environmental Monitoring Program. Modifications to the program shall be reported in the Annual Radiological Environmental Operating Report to the Nuclear Regulatory Commission.
3. If the level of radioactivity in an environmental sampling medium exceeds the reporting level specified in Table 5.4, and the activity is attributable to facility operation, a Special Report shall be prepared and submitted to the Nuclear Regulatory Commission within 30 days (Section 6.2.4). The detection capabilities of the equipment used for the analysis of environmental samples must meet the requirements of Table 5.3 for Lower Level of Detection (LLD).

5.1.1A (continued)

4. If the level of radioactivity in a sample from either an onsite or offsite well, performed per the Site Groundwater Protection Program, exceeds the reporting level specified in Table 5.4, and the activity is attributable to facility operation, a Special Report shall be prepared and submitted to the Nuclear Regulatory Commission within 30 days (Section 6.2.4). The detection capabilities of the equipment used for the analysis of environmental samples must meet the requirements of Table 5.3 for Lower Level of Detection (LLD). Copies of the Special Report will be forwarded to State/Local authorities. **[AR 39127]**
5. If the level of radioactivity from either an onsite or offsite well, performed per the Site Groundwater Protection Program exceeds the reporting level specified in Table 5.4, and the activity is attributable to facility operations, state and local authorities shall be notified by the end of the next business day. NRC shall be notified per FCSI-RA-105, Reporting of Events and Conditions. **[AR 39127]**
6. Radiological environmental sampling locations and the media that is utilized for analysis are presented in Table 5.2. Sampling locations are also illustrated on the map, Figure 1. Details of the quarterly emergency TLD locations are contained in surveillance test CH-FT-RV-0003, Environmental Sample Collection – Quarterly/Environmental Dosimeters (TLDs). Each TLD sample location contains one dosimeter that is exchanged quarterly for REMP sampling and as needed for Emergency Planning Zone monitoring.
7. Deviations from the monitoring program, presented in this section and detailed in Table 5.2, are permitted if specimens are unobtainable due to mitigating circumstances such as hazardous conditions, seasonal unavailability, malfunction of equipment, or if a person discontinues participation in the program, etc. If the equipment malfunctions, corrective actions will be completed as soon as practicable. If a person no longer supplies samples, a replacement will be made if possible. All deviations from the sampling schedule will be described in the Annual Radiological Environmental Operating Report, pursuant to Section 6.2.

5.1.2 Surveillance Requirements

- A. The Radiological Environmental Monitoring Program (REMP) samples shall be collected and analyzed in accordance with Tables 5.1, 5.2, and 5.3.

Table 5.1 - Radiological Environmental Monitoring Program

Exposure Pathway and/or Sample	Collection Site ^A	Type of Analysis ^B	Frequency
1. Direct Radiation	A. 14 TLD indicator stations.	Gamma dose	Quarterly
	B. An inner-ring of 16 stations, one in each cardinal sector in the general area of the unrestricted area boundary and within 2.5 miles.	Gamma dose	Quarterly
	C. An outer-ring of 16 background stations, one in each cardinal sector located outside of the inner-ring, but not closer than approximately 2.5 miles and one additional remote background station for a total of 17. ^F	Gamma dose	Quarterly
	D. Other TLDs may be placed at special interest locations beyond the Restricted Area where either a MEMBER OF THE PUBLIC or Omaha Public Power District employees have routine access.	Gamma dose	Quarterly
2. Air Monitoring	A. Indicator Stations 1. Three stations in the general area of the unrestricted area boundary 2. City of Blair 3. Desoto Township	Filter for Gross Beta ^C Filter for Gamma Isotopic	Weekly Quarterly composite of weekly filters
	B. One background station ^F		
3. Water	A. Missouri River at nearest downstream drinking water intake.	Gamma Isotopic, H-3	Monthly for Gamma isotopic analysis.
	B. Missouri River downstream near the mixing zone.		Quarterly composite for H-3 Analysis
	C. Missouri River upstream of Facility intake (background) ^F .		
4. Milk ^D	A. Nearest milk animal (cow or goat) within 5 miles	Gamma Isotopic	Monthly
	B. Milk animal (cow or goat) between 5 miles and 18.75 miles (background) ^F .		

Table 5.1 - Radiological Environmental Monitoring Program

Exposure Pathway and/or Sample	Collection Site ^A	Type of Analysis ^B	Frequency
5. Fish	A. Four fish samples within vicinity of Facility discharge. B. One background sample upstream of Facility discharge.	Gamma Isotopic	Once per season (May to October)
6. Vegetables or Food Products ^E	A. One sample in the highest exposure pathway. B. One sample from onsite crop field C. One sample outside of 5 miles (background) ^F .	Gamma Isotopic	Once per season (May to October)
7. Groundwater	A. Three samples from sources potentially affected by facility operations. B. One sample outside of 5 miles (background) ^F .	H ₃ , Gross Beta, Gamma Isotopic, Sr-90	Quarterly
8. Vegetation in lieu of milk	A. One sample at the highest annual average D/Q offsite location. B. One sample at the second highest annual average D/Q offsite location. C. One sample outside of 5 miles (background) ^F .	Gamma Isotopic	Monthly (when available)

NOTES:

- A. See Table 5.3 for required detection limits.
- B. The Lower Limit of Detection (LLD) for analysis is defined in the Off-Site Dose Calculation Manual in accordance with the wording of NUREG-1301.
- C. When a gross beta count indicates radioactivity greater than $2.5E-13$ $\mu\text{Ci/ml}$ or 0.25 pCi/m^3 , (ten times the yearly mean), a gamma spectral analysis will be performed.
- D. If milk samples are temporarily not available at a sampling site due to mitigating circumstances, then vegetation (broadleaf, pasture grass, etc.) shall be collected as an alternate sample at the site. If there are no milk producers within the entire 5-mile radius of the facility, then vegetation shall be collected monthly, when available, at two offsite locations having the highest calculated annual average ground level D/Q and a background locale. (Reference Off-Site Dose Calculation Manual, Part II, Table 4 "Highest Potential Exposure Pathways for Estimating Dose")
- E. Samples should be collected from garden plots of 500 ft^2 or more. (Reference Reg. Guide 4.8 "Environmental Technical Specifications for Nuclear Power Plants," Dec. 1975).
- F. This sample may not be located in the least prevalent wind direction. The Branch Technical Position paper, Table 1, subnote "d" says this regarding background information, or control locations. **"The purpose of this sample is to obtain background information. If it is not practical to establish control locations in accordance with the distance and wind direction criteria, other sites which provide valid background data may be substituted".**

Table 5.2 - Radiological Environmental Sampling Locations And Media

Sample Station No.	Approximate Collection Sites	Approximate Distance from Center of Containment (miles)	Approximate Direction (degrees from true north)	Sector	Air Monitoring	TLD	Water	Milk	Sedi-ment	Fish	Vegetables and Food Products	Ground-water
					Airborne Particulate							
1	Onsite Station, 110-meter weather tower	0.53	293°/WNW	P		X						
2 ^{C,E}	Onsite Station, adjacent to old plant access road	0.59	207°/SSW	K	X	X						
3	Offsite Station, Intersection of Hwy. 75 and farm access road	0.94	145°/SE	G		X						
4	Blair OPPD office	2.86	305°/NW	Q	X	X						
5 ^A												
6	Fort Calhoun, NE City Hall	5.18	150°/SSE	H		X						
7	Fence around intake gate, Desoto Wildlife Refuge	2.07	102°/ESE	F		X						
8	Onsite Station, entrance to Plant Site from Hwy. 75	0.55	191°/S	J		X						
9	Onsite Station, NW of Plant	0.68	305°/NW	Q		X						
10	Onsite Station, WSW of Plant	0.61	242°/WSW	M		X						
11	Offsite Station, SE of Plant	1.07	39°/SE	G		X						

Table 5.2 - Radiological Environmental Sampling Locations And Media

Sample Station No.	Approximate Collection Sites	Approximate Distance from Center of Containment (miles)	Approximate Direction (degrees from true north)	Sector	Air Monitoring	TLD	Water	Milk	Sedi-ment	Fish	Vegetables and Food Products	Ground-water
					Airborne Particulate							
28 ^A												
29 ^A												
30 ^A												
31 ^A												
32 ^D	Valley Substation #902	19.6	221°/SW	L	X	X						
33 ^A												
34 ^A												
35	Onsite Farm Field	0.52	118°/ESE	F							X	
36	Offsite Station Intersection Hwy 75/Co. Rd. P37	0.75	227°/SW	L		X						
37	Offsite Station Desoto Township	1.57	144°/SE	G	X	X						
38 ^A												
39 ^A												
40 ^A												
41 ^{B,C}	Dowler Acreage	0.73	175°/S	J	X	X						
42	Sector A-1	1.94	0°/NORTH	A		X						
43	Sector B-1	1.97	16°/NNE	B		X						
44	Sector C-1	1.56	41°/NE	C		X						
45	Sector D-1	1.34	71°/ENE	D		X						
46	Sector E-1	1.54	90°/EAST	E		X						
47	Sector F-1	0.45	108°/ESE	F		X						

Table 5.2 - Radiological Environmental Sampling Locations And Media

Sample Station No.	Approximate Collection Sites	Approximate Distance from Center of Containment (miles)	Approximate Direction (degrees from true north)	Sector	Air Monitoring	TLD	Water	Milk	Sedi-ment	Fish	Vegetables and Food Products	Ground-water
					Airborne Particulate							
48	Sector G-1	1.99	134°/SE	G		X						
49	Sector H-1	1.04	159°/SSE	H		X						
50	Sector J-1	0.71	179°/SOUTH	J		X						
51	Sector K-1	0.61	205°/SSW	K		X						
52	Sector L-1	0.74	229°/SW	L		X						
53	Sector M-1	0.93	248°/WSW	M		X						
54	Sector N-1	1.31	266°/WEST	N		X						
55	Sector P-1	0.60	291°/WNW	P		X						
56	Sector Q-1	0.67	307°/NW	Q		X						
57	Sector R-1	2.32	328°/NNW	R		X						
58 ^D	Sector A-2	4.54	350°/NORTH	A		X						
59 ^D	Sector B-2	2.95	26°/NNE	B		X						
60 ^D	Sector C-2	3.32	50°/NE	C		X						
61 ^D	Sector D-2	3.11	75°/ENE	D		X						
62 ^D	Sector E-2	2.51	90°/EAST	E		X						
63 ^D	Sector F-2	2.91	110°/ESE	F		X						
64 ^D	Sector G-2	3.00	140°/SE	G		X						
65 ^D	Sector H-2	2.58	154°/SSE	H		X						
66 ^D	Sector J-2	3.53	181°/SOUTH	J		X						
67 ^D	Sector K-2	2.52	205°/SSW	K		X						
68 ^D	Sector L-2	2.77	214°/SW	L		X						
69 ^D	Sector M-2	2.86	243°/WSW	M		X						

Table 5.2 - Radiological Environmental Sampling Locations And Media

Sample Station No.	Approximate Collection Sites	Approximate Distance from Center of Containment (miles)	Approximate Direction (degrees from true north)	Sector	Air Monitoring	TLD	Water	Milk	Sedi-ment	Fish	Vegetables and Food Products	Ground-water
					Airborne Particulate							
70 ^D	Sector N-2	2.54	263°/WEST	N		X						
71 ^D	Sector P-2	2.99	299°/WNW	P		X						
72 ^D	Sector Q-2	3.37	311°/NW	Q		X						
73 ^D	Sector R-2	3.81	328°/NNW	R		X						
74	D. Miller Farm	0.65	203°/SSW	K								X
75 ^{B,C}	Lomp Acreage	0.65	163°/SSE	H	X	X					X	X
76 ^A												
77 ^G	River N-1	0.17	328°/NNW	R		X						
78 ^G	River S-1	0.14	85°/EAST	E		X						
79 ^G	Lagoon S-1	0.24	131°/SE	G		X						
80 ^G	Parking S-1	0.27	158°/SSE	H		X						
81 ^G	Training W-1	0.28	194°/SSW	K		X						
82 ^G	Switchyard S-1	0.21	219°/SW	L		X						
83 ^G	Switchyard SE-1	0.14	231°/SW	L		X						
84 ^G	Switchyard NE-1	0.18	256°/WSW	M		X						
85 ^G	Switchyard W-1	0.29	233°/WEST	L		X						
86 ^G	Switchyard N-1	0.24	262°/WEST	N		X						
87 ^G	Range S-1	0.20	286°/WNW	P		X						
88 ^G	Mausoleum E-1	0.37	216°/SW	L		X						
89	C, Miller	3.30	210°/SSW	K				X				

NOTES:

- A. Location is either not in use or currently discontinued and is documented in the table for reference only.
- B. If milk samples are temporarily not available at a sampling site due to mitigating circumstances, then vegetation (broadleaf, pasture grass, etc.) shall be collected as an alternate sample at the site. If there are no milk producers within the entire 5-mile radius of the facility, then vegetation shall be collected monthly, when available, at two offsite locations having the highest calculated annual average ground level D/Q and a background locale. (Reference Off-Site Dose Calculation Manual, Part II, Table 4 "Highest Potential Exposure Pathways for Estimating Dose")
- C. Locations represent highest potential exposure pathways as determined by the biennial Land Use Survey, performed in accordance with Part I, Section 7.3.2, of the Off-Site Dose Calculation Manual and are monitored as such.
- D. Background location (control). All other locations are indicators.
- E. Location for monitoring Sector K High Exposure Pathway Resident Receptor for inhalation.
- F. When broad leaf (pasture grasses) are being collected in lieu of milk, background broad leaf samples will be collected at a background locale.
- G. Location for special interest monitoring general dose to the public per 40CFR190 (Figure 2)

Figure 1 – Environmental Radiological Sampling Points

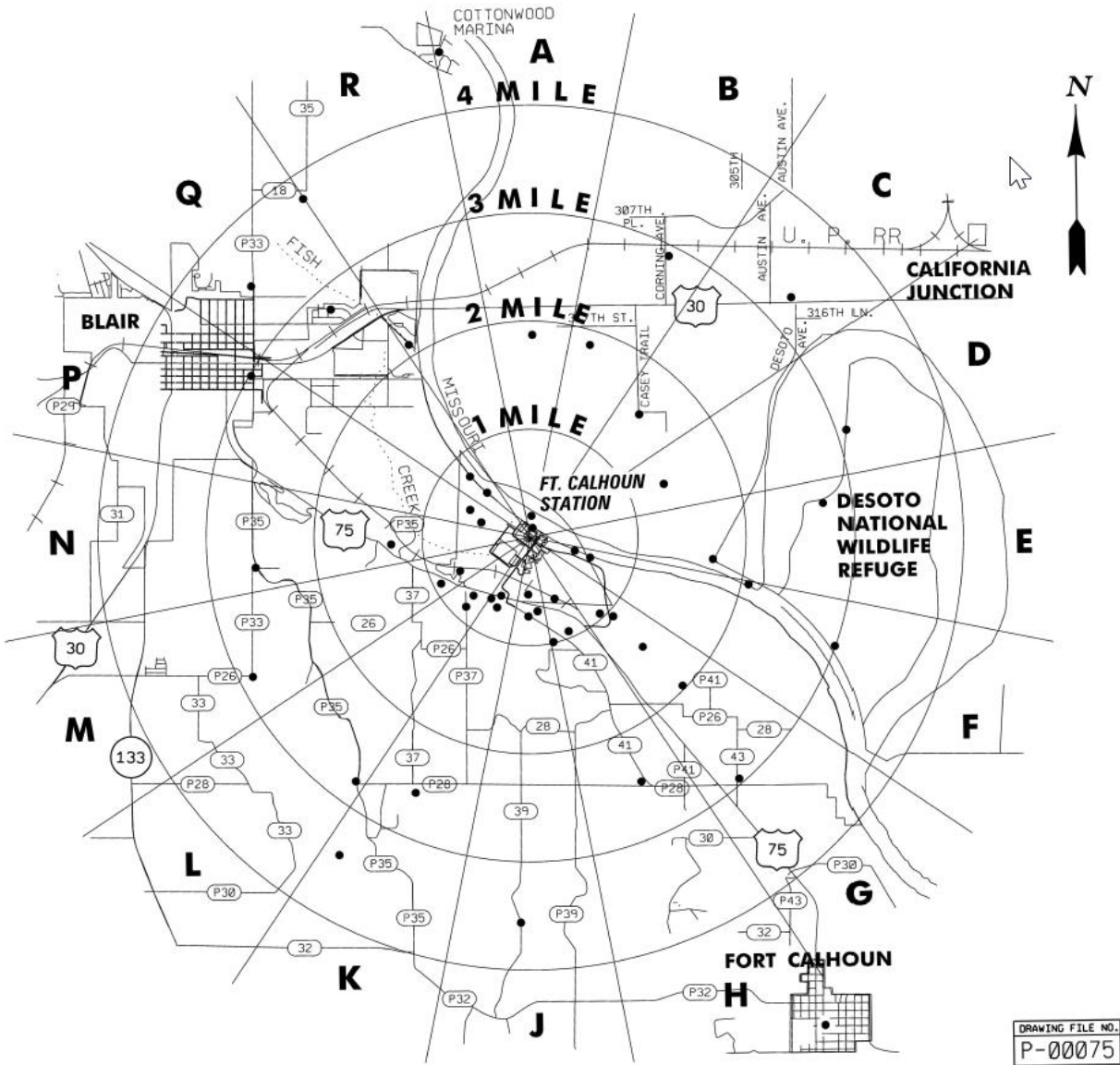

(*) Locations currently discontinued are not illustrated.

Figure 2- 40CFR190 Sampling Points

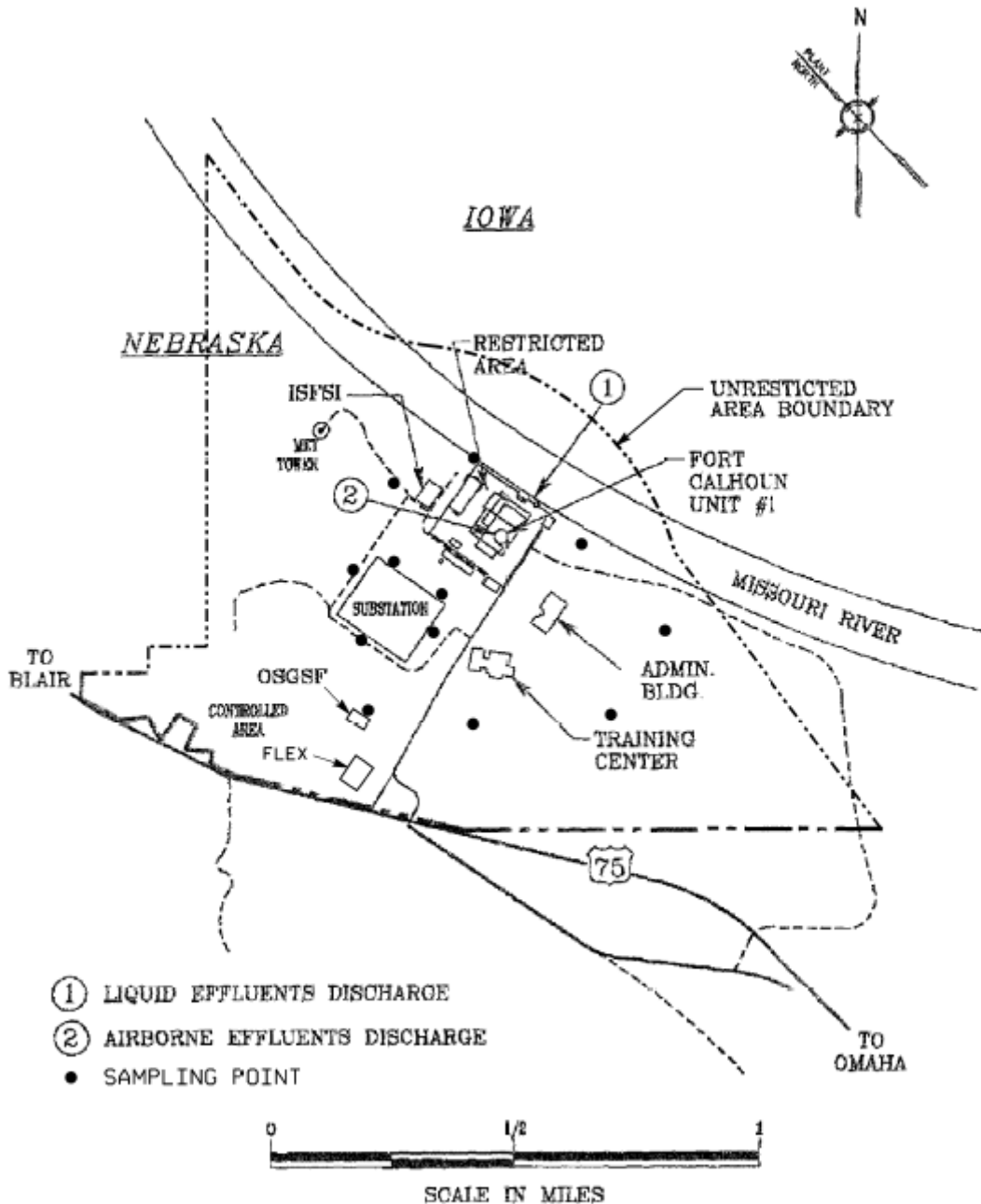

SITE BOUNDARY MAP

DRAWING FILE NO.
P-00423

Table 5.3 - Detection Capabilities for Environmental Sample Analysis Lower Limit of Detection (LLD) ^{A, B, C}

Sample	Units	Gross Beta	H-3	Mn-54	Fe-59	Co-58, Co-60	Zn-65	Zr-95	Nb-95	Cs-134	Cs-137	Ba-140 La-140
Water	pCi/L	4	2.0E+03	1.5E+01	3.0E+01	1.5E+01	3.0E+01	1.5E+01	1.5E+01	1.5E+01	1.8E+01	1.5E+01
Fish	pCi/kg (wet)	---	---	1.3E+02	2.6E+02	1.3E+02	2.6E+02	---	---	1.3E+02	1.5E+02	---
Milk	pCi/L	---	---	---	---	---	---	---	---	1.5E+01	1.8E+01	1.5E+01
Airborne Particulates	pCi/m ³	1.0E-02	---	---	---	---	---	---	---	1.0E-02	1.0E-02	---
Sediment	pCi/kg (dry)	---	---	---	---	---	---	---	---	1.5E+02	1.8E+02	---
Grass or Broad Leaf Vegetation/ Vegetables or Food Products	pCi/kg (wet)	---	---	---	---	---	---	---	---	6.0E+01	8.0E+01	---

- A. This list does not mean that only these nuclides are to be considered. Other peaks that are identifiable as Facility effluents, together with those of the above nuclides, shall also be analyzed and reported in the Annual Radiological Environmental Operating Report pursuant to Part I, Section 6.2, of the Off-Site Dose Calculation Manual.
- B. Required detection capabilities for thermoluminescent dosimeters used for environmental measurements shall be in accordance with the recommendations of Regulatory Guide 4.13.
- C. The LLD is defined in Part II of the Off-Site Dose Calculation Manual.

Table 5.4 - Reporting Levels for Radioactivity Concentrations in Environmental Samples ^A

Sample	Units	H-3	Mn-54	Fe-59	Co-58	Co-60	Zn-65	Zr-95	Nb-95	Cs-134	Cs-137	Ba-140 La-140
Water	pCi/L	2.0E+04	1.0E+03	4.0E+02	1.0E+03	3.0E+02	3.0E+02	4.0E+02	4.0E+02	3.0E+01	5.0E+01	2.0E+02
Fish	pCi/kg (wet)	---	3.0E+04	1.0E+04	3.0E+04	1.0E+04	2.0E+04	---	---	1.0E+03	2.0E+03	---
Milk	pCi/L	---	---	---	---	---	---	---	---	6.0E+01	7.0E+01	3.0E+02
Airborne Particulates	pCi/m ³	---	---	---	---	---	---	---	---	1.0E+01	2.0E+01	---
Grass or Broad Leaf Vegetation/ Vegetables or Food Products	pCi/kg (wet)	---	---	---	---	---	---	---	---	1.0E+03	2.0E+03	---

A. A Non-routine report shall be submitted when more than one of the radionuclides listed above are detected in the sampling medium and:

$$\frac{\text{Concentration 1}}{\text{Reporting Level 1}} + \frac{\text{Concentration 2}}{\text{Reporting Level 2}} + \frac{\text{Concentration 3}}{\text{Reporting Level 3}} + \dots \geq 1.0$$

When radionuclides other than those listed above are detected and are the result of Facility effluents, this report shall be submitted if the potential annual dose to a member of the general public is equal to or greater than the dose objectives of Part I, Section 4.1 and 4.2, of the Off-Site Dose Calculation Manual. This report is not required if the measured level of radioactivity was not the result of Facility effluents; however, in such an event, the condition shall be reported and described in the Annual Radiological Environmental Operating Report.

5.2 Land Use Survey

5.2.1 Limiting Condition for Operation

A. A Land Use Survey shall identify the location of the nearest milk animal, nearest meat animal, nearest vegetable garden, nearest groundwater source and the nearest residence in each of the 16 cardinal sectors within a distance of five miles. The survey shall be conducted under the following conditions:

1. Within a one-mile radius from the Facility site, enumeration by door-to-door or equivalent counting techniques.
2. Within a Five-mile radius, enumeration may be conducted door-to-door or by using referenced information from county agricultural agents or other reliable sources.

APPLICABILITY: At all times

ACTION:

- a. If it is learned from this survey that milk animals, vegetable gardens and resident receptors are present at a location which yields a calculated dose greater than 20% from previously sampled location(s), the new location(s) shall be added to the monitoring program. Milk and vegetable garden sampling location(s) having the lowest calculated dose may then be dropped from the monitoring program at the end of the grazing and/or growing season during which the survey was conducted and the new location added to the monitoring program. Groundwater monitoring is based on a determination if source(s) are potentially affected by facility operations. Modifications to the air monitoring locations, vegetable garden sampling locations, and milk sampling locations will be made as soon as practicable. The Nuclear Regulatory Commission shall be notified of modifications to the program in the Annual Radiological Environmental Operating Report (Section 6.2).

5.2.1A.2 (continued)

- b. If it is learned from this survey that a pathway for dose to a MEMBER OF THE GENERAL PUBLIC no longer exists, an additional pathway has been identified or site specific factors affecting the dose calculations for a pathway have changed, then this information should be documented in the Land Use Survey, the Annual Radiological Environmental Operating Report and the Annual Radioactive Effluent Release Report. This information can be used to increase the accuracy of the dose models for the Annual Radioactive Effluent Release Report as well as dose estimates performed during the reporting period (i.e., quarterly dose estimates).

5.2.2 Surveillance Requirements

- A. A land use survey shall be conducted once per 24 months between the dates of June 1 and October 1. The results of the land use survey shall be submitted to the Nuclear Regulatory Commission in the Annual Radiological Environmental Operating Report (Section 6.2) for the year it was performed.

5.3 Interlaboratory Comparison Program

5.3.1 Limiting Condition for Operation

- A. Analyses shall be performed on radioactive materials as part of an Interlaboratory Comparison Program that has been approved by the Nuclear Regulatory Commission.

APPLICABILITY: At all times

ACTION:

1. With analysis not being performed as required above, report the corrective actions taken to prevent a recurrence to the Commission in the Annual Radiological Environmental Operating Report (Section 6.2).

5.3.2 Surveillance Requirements

- A. The results of these analyses shall be included in the Annual Radiological Environmental Operating Report (Section 6.2).

6.0 **ADMINISTRATIVE CONTROLS**

6.1 Responsibilities

- 6.1.1 FCS RP/Chemistry Department is responsible for the implementation and maintenance of the Off-Site Dose Calculation Manual.
- 6.1.2 ISFSI Shift Supervisor (ISS) is responsible for the compliance with the Off-Site Dose Calculation Manual in the operation of Fort Calhoun Station.

6.2 Radioactive Effluent Reporting Requirements

The reporting requirements for radioactive effluents stated in this Section are to provide assurance that the limits set forth in Part I of the Off-Site Dose Calculation Manual are complied with. These reports will meet the requirements for documentation of radioactive effluents contained in 10 CFR Part 50.36a; Reg. Guide 1.21, Rev. 2; Reg. Guide 4.8, Table 1; and Reg. Guide 1.109, Rev. 1.

6.2.1 Annual Radioactive Effluent Release Report

A report covering the operation of the Fort Calhoun Station during the previous calendar year shall be submitted prior to May 1 of each year per the requirements of QATR Appendix E, E.4.1 and 10 CFR Part 50.

The Radioactive Effluent Release Report shall include:

- A. A summary of the quantities of radioactive liquid and airborne effluents and solid waste released from the facility as outlined in Regulatory Guide 1.21, Revision 2.
- B. A summary of the historical average meteorological data that provides joint frequency distributions of wind direction and wind speed by atmospheric stability class will be included in the annual report.
- C. An assessment of radiation doses from the radioactive liquid and airborne effluents released from the unit during each calendar quarter as outlined in Regulatory Guide 1.21, Revision 2. The assessment of radiation doses shall be performed in accordance with calculational methodology of the Regulatory Guide 1.109, Revision 1.
- D. Changes to the Process Control Program (PCP) or to the Offsite Dose Calculation Manual (ODCM) made during the reporting period. Each change shall be identified by markings in the margin of the affected pages clearly indicating the area of the page that was changed and shall indicate the date the change was implemented.

6.2.1 (continued)

- E. A list and description of abnormal releases or abnormal discharges from the site to unrestricted areas of radioactive materials in gaseous and liquid effluents made during the reporting period.
- F. An explanation of why instrumentation designated in Part I, Sections 3.1.1 and 3.2, of the Off-Site Dose Calculation Manual, was not restored to FUNCTIONAL status within 30 days.
- G. A description of any major design changes or modifications made to the Liquid and/or Gaseous Radwaste Treatment Systems or Ventilation Exhaust Systems during the reporting period.
- H. An explanation of why the liquid and/or gaseous radwaste treatment systems were not FUNCTIONAL, causing the limits of specifications 4.1.3A and 4.2.3A to be exceeded.
- I. The results of sampling from offsite and onsite groundwater wells per the Site Groundwater Protection Plan. **[AR 39127]**
- J. Non-routine planned discharges (e.g., discharges from remediation efforts like pumping contaminated groundwater from a leak).

6.2.2 Annual Radiological Environmental Operating Report

The Annual Radiological Environmental Operating Report for the previous one year of operation shall be submitted prior to May 1 of each year. This report contains the data gathered from the Radiological Environmental Monitoring Program. The content of the report shall include:

- A. Summarized and tabulated results of the radiological environmental sampling/analysis activities following the format of Regulatory Guide 4.8, Table 1. In the event that some results are not available, the report shall be submitted noting and explaining the reasons for the missing results. The missing data shall be submitted as soon as possible in a supplementary report.
- B. Interpretations and statistical evaluation of the results, including an assessment of the observed impacts of the facility operation and environment.
- C. The results of participation in a NRC approved Interlaboratory Comparison Program.
- D. The results of land use survey required by Section 5.2.
- E. A map of the current environmental monitoring sample locations.

6.2.3 Independent Spent Fuel Storage Installation Annual Radioactive Effluent Release Report.

The Independent Spent Fuel Storage Installation Annual Radioactive Effluent Release Report must be submitted within 60 days after the end of the 12-month monitoring period, per 10 CFR 72.44(d)(3).

- A. A Summary of the quantity of each of the principal radionuclides released to the environment in liquid and in gaseous effluents during the previous 12 months and such other information as may be required by the Commission to estimate maximum potential radiation dose commitment to the public resulting from effluent releases.

6.2.4 Special Report

If the limits or requirements of Sections 4.1.2A, 4.1.3A, 4.2.2A, 4.3.1A, and/or 5.1.1A.3 and/or 5.1.1A.4 are exceeded, a Special Report shall be issued to the Commission, pursuant to QATR Appendix E, E.2. This report shall include: **[AR 39127]**

- A. The results of an investigation to identify the causes for exceeding the specification.
- B. Define and initiate a program of action to reduce levels to within the specification limits.
- C. The report shall also include an evaluation of any release conditions, environmental factors, or other aspects necessary to explain the condition.

6.2.5 EPA 40 CFR Part 190 Reporting Requirements

With the calculated dose from the release of radioactive materials in liquid or gaseous effluents exceeding twice the limits of dose from specifications 4.1.2A or 4.2.2A, calculations shall be made including direct radiation calculations, to prepare and submit a special report to the Commission within 30 days and limit the subsequent releases such that the dose to any real individual from uranium fuel cycle sources is limited to ≤ 25 mrem to the total body or any organ (except thyroid, which is limited to ≤ 75 mrem) over the calendar year. This special report shall include an analysis which demonstrates that radiation exposures to any member of the public from uranium fuel cycle sources (including all effluent pathways and direct radiation) are less than the 40 CFR Part 190 standard. Otherwise, obtain a variance from the Commission to permit releases which exceed the 40 CFR Part 190 standard. The submittal of the report is to be considered a timely request and a variance is granted pending the final action on the variance request from the Commission.

6.2.6 ISFSI 10 CFR Part 72.104 Reporting Requirements

The regulatory requirements of 10CFR20, 10CFR72 and 40CFR190 each limit total dose to individual members of the public without regard to specific pathways. The only significant exposure pathways for light water reactors included in 10CFR20, 10CFR72 and 40CFR190 not addressed by 10CFR50 Appendix I are the direct radiation pathway and exposure from on-site activity by members of the public.

The 10CFR72.104 dose limits are the same as those specified in 40CFR190. ISFSI dose contribution is in the form of direct radiation as no liquid or gas releases are expected to occur. If the dose limits of 40CFR190 or 10CFR72.104 are exceeded, a special report to the NRC, as well as an appropriate request for exemption/variance, is required to be submitted to the NRC.

The requirement that the dose limits of 10CFR72.104 apply to any 'real individual' is controlled for ISFSI activities in the ISFSI 72.212 report. Therefore, for the purposes of analyzing dose from the ISFSI, the member of the public as defined in 40CFR190 is the same as for the 'real individual'.

The external Total Body Dose is comprised of:

- 1) Total Body Dose due to noble gas radionuclides in gaseous effluents
- 2) Dose due to radioactive waste and the ISFSI
- 3) Total Body Dose due to radioactivity deposited on the ground (this dose is accounted for in the determination of the non-noble gas dose and is not considered here)

Dose from onsite storage (such as the ISFSI) is given by:

$D_{osf} = \max \text{ of } :$

(TLD dose from indicator TLD i – average of all background TLDs)
* occupancy factor at TLD i

Neutron dose is found by multiplying gamma dose by a neutron/gamma ratio determined from other site TLDs around the ISFSI.

The Total Body Dose, external is given by:

$D_{ext} = D_{tb} + D_{osf}$

Where D_{ext} is the external dose

D_{tb} is the total body dose

D_{osf} is the dose from on-site storage

The Total Dose is then given by:

$D_{tot} = D_{ext} + D_{liq} + D_{nng}$

Where D_{tot} is the total dose

D_{ext} is the external dose

D_{liq} is the dose from liquid effluents

D_{nng} is the dose from non-noble gases

Dose Limits

Total Body, annual	25 mrem
Thyroid, annual	75 mrem
Other Organs, annual	25 mrem

6.3 Change Mechanism

The Off-Site Dose Calculation Manual is the controlling document for all radioactive effluent releases. It is defined as a procedure under the guidance of QATR Section 5. It will be revised and reviewed by the Safety Review Committee and approved by the Plant Manager in accordance with QATR Appendix E, E.1.2. All changes to the Off-Site Dose Calculation Manual will be forwarded to the Nuclear Regulatory Commission during the next reporting period for the Annual Radioactive Effluent Release Report in accordance with the requirements of QATR Appendix E, E.1.2.

6.4 Meteorological Data

The historical Average χ/Q is utilized to determine the concentrations of radionuclides at the unrestricted area boundary. It is also the factor used in conjunction with the parameters and methodologies in Part II, of the Off-Site Dose Calculation Manual to determine unrestricted area dose on a quarterly bases or as needed. It is based on an average of the highest calculated sector χ/Q values, using all 16 sectors for previous multiple years Annual Radioactive Effluent Release Reports, and the XOQDOQ plume trajectory model. An additional 10 percent will be added to the average for unrestricted area dose estimates performed quarterly or as needed for conservatism. XOQDOQ model conforms with the Nuclear Regulatory Commissions Regulatory Guide 1.111.

Historical average meteorological data will be utilized in the preparation of the Annual Radioactive Effluent Release Report. Prior years of data is used to calculate the joint frequency table, the dispersion coefficients and deposition factors in all 16 sectors. These are used in the calculation of doses to individuals in unrestricted areas as a result of the operation of Fort Calhoun Station. The models used, GASPAR 2 and LADTAP 2, meet the intent of Nuclear Regulatory Commissions Reg. Guide 1.109 and 1.21 for the reporting of doses due to routine radioactive effluent releases.

6.5 References

- 6.5.1 Regulatory Guide 1.109, Rev. 1 - Calculation of Annual Dose to man from Routine Releases of Reactor Effluents for the purpose of evaluation compliance with 10 CFR Part 50, Appendix I
- 6.5.2 Regulatory Guide 1.111, Rev. 1 - Methods for Estimating Atmospheric Transport and Dispersion of Gaseous Effluents in Routine Releases from Light-Water-Cooled Reactors.
- 6.5.3 Regulatory Guide 1.113, Rev. 1 - Estimating Aquatic Dispersion of Effluents from Accidental and Routine Releases for the purpose of Implementing Appendix I.
- 6.5.4 Regulatory Guide 4.8, Environmental Technical Specification for Nuclear Power Plants.
- 6.5.5 NRC Branch Technical Position, March 1978
- 6.5.6 NUREG-0133 - Preparation of Radiological Effluent Technical Specifications for Nuclear Power Plants.
- 6.5.7 NUREG-1301 - Offsite Dose Calculation Manual Guidance.
- 6.5.8 Regulatory Guide 1.21, Rev. 2 - Measuring, Evaluating, and Reporting Radioactivity in solid wastes and Releases of Radioactivity Materials in Liquid and Gaseous Effluents from Light-Water-Cooled Nuclear Power Plants.
- 6.5.9 Code of Federal Regulations, Title 10, Part 20
- 6.5.10 Code of Federal Regulations, Title 10, Part 50
- 6.5.11 Code of Federal Regulations, Title 10, Part 72
- 6.5.12 Code of Federal Regulations, Title 40, Part 190
- 6.5.13 Fort Calhoun Revised Environmental Report (Unit No. 1)-1972
- 6.5.14 NO-FC-10, Quality Assurance Topical Report
- 6.5.15 Defueled Safety Analysis Report
- 6.5.16 AR 12357, Implement Recommendations of Memo FC-0133-92, Part I, Table 3.2.1 Action 4, of the Off-Site Calculation Manual
- 6.5.17 AR 39127, NEI Industry Initiative on Groundwater Protection

- 6.5.18 Regulatory Guide 4.1, Rev. 2 – Radiological Environmental Monitoring for Nuclear Power Plants
- 6.5.19 FC-19-001, ODCM rev 29 Change Support Document
- 6.5.20 FC-18-005, Habits of the Real Individual in Vicinity of Fort Calhoun Station, X/Q, Direct Radiation Dose Calculation

7.0 **BASIS**

7.1 Instrumentation

7.1.1 Radioactive Liquid Effluent Instrumentation

The Radioactive liquid effluent instrumentation is provided to monitor and control, as applicable, the releases of radioactive material in liquid effluents during actual or potential releases of liquid effluents. The Alarm/Trip setpoints for these instruments shall be calculated in accordance with Part II of the Offsite Dose Calculation Manual to ensure that the alarm/trip will occur prior to exceeding the limits of 10 CFR Part 20. The FUNCTIONALITY and use of this instrumentation is consistent with the requirements of DSAR- Appendix G Criterion 17 – Monitoring Radioactive Releases, Criterion 18 – Monitoring Fuel and Waste Storage, and Criterion 70 – Control of Release of Radioactivity to the Environment.

7.1.2 Radioactive Gaseous Effluent Instrumentation

The Radioactive gaseous effluent instrumentation is provided to monitor and control, as applicable, the releases of radioactive material in gaseous effluents during actual or potential releases of gaseous effluents.

7.2 Radioactive Effluents

7.2.1 Radioactive Liquid Effluents

A. Concentration

This specification is provided to ensure that the concentration of radioactive materials released in liquid waste effluents from the site to unrestricted areas will be less than 10 times the concentration levels specified in 10 CFR Part 20, Appendix B, Table II, Column 2. This limitation provides additional assurance that the levels of radioactive materials in bodies of water outside the site will result in exposures within (1) the Section II.A design objectives of Appendix I, 10 CFR Part 50, and (2) the limits of 10 CFR Part 20.1001-20.2401 to the population.

B. Dose

This specification is provided to implement the requirements of Sections II.A, III.A and IV.A of Appendix I, 10 CFR Part 50. The Limiting Condition for Operation implements the guides set forth in Section II.A of Appendix I. The ACTION statements provide the required operating flexibility and at the same time implement the guides set forth in Section IV.A of Appendix I to assure that the releases of radioactive material in liquid effluents will be kept "as low as is reasonably achievable". Also, with fresh water sites with drinking water supplies which can be potentially affected by facility operations, there is reasonable assurance that the operation of the facility will not result in radionuclide concentrations in the finished drinking water that are in excess of the requirements of 40 CFR Part 141. The dose calculation methodology and parameters in Part II of the Off-Site Dose Calculation Manual, implement the requirements in Section III.A that conformance with the guides of Appendix I is to be shown by calculational procedures based on models and data such that the actual exposure of an individual through appropriate pathways is unlikely to be substantially underestimated. The equations specified in Part II of the Off-Site Dose Calculation Manual, for calculating the doses due to the actual release rates of radioactive material in liquid effluents are consistent with the methodology provided in Regulatory Guide 1.109, "Calculation of Annual Doses to Man from Routine Releases of Reactor Effluents for the Purpose of Evaluating Compliance with 10 CFR Part 50, Appendix I," Revision 1, October 1977, and Regulatory Guide 1.113, "Estimating Aquatic Dispersion of Effluents from Accidental and Routine Reactor Releases for the Purpose of Implementing Appendix I," April 1977.

C. Liquid Waste Treatment System

The FUNCTIONALITY of the liquid radwaste treatment system ensures that this system will be available for use whenever liquid effluents require treatment prior to release to the environment. The requirement that appropriate portions of this system be used when specified provides assurance that the releases of radioactive materials in liquid effluents will be kept "as low as is reasonably achievable". This specification implements the requirements of 10 CFR Part 50.36a, General Design Criterion 60 of Appendix A to 10 CFR Part 50 and design objective and in Section II.D of Appendix I to 10 CFR Part 50. The specified limits governing the use of appropriate portions of the liquid radwaste treatment system were specified to ensure the design objectives set forth in Section II.A of Appendix I, 10 CFR Part 50 for liquid effluents are not exceeded.

D. Liquid Holdup Tanks

Restricting the quantity of radioactive material contained in the specified tanks provides assurance that in the event of an uncontrolled release of the tanks' contents, the resulting concentrations would be less than the limits of 10 CFR Part 20, Appendix B, Table II, Column 2, at the nearest potable water supply and the nearest surface water supply in an unrestricted area.

7.2.2 Radioactive Gaseous Effluents

A. Concentration

This specification, in conjunction with Steps 4.2.2A, is provided to ensure that the dose at or beyond the Site Boundary from gaseous effluents will be within the annual dose limits of 10 CFR Part 20 for MEMBERS OF THE PUBLIC. The release rate of radioactive material in airborne effluents shall be controlled such that the instantaneous concentrations for these radionuclides do not exceed the values specified in 10 CFR Part 20 for airborne effluents at the unrestricted area boundary.

B. Dose - Radioactive Material in Particulate Form with Half-Lives Greater than Eight Days (Other than Noble Gases) and Tritium

This specification is provided to implement the requirements of Sections II.C, III.A and IV.A of Appendix I, 10 CFR Part 50. The Limiting Condition For Operation implements the guides set forth in Section II.C of Appendix I. The ACTION statements provide the required operating flexibility and at the same time implement the guides set forth in Section IV.A of Appendix I assure that the releases of radioactive material in gaseous effluents will be kept as low as is reasonably achievable. The surveillance requirements implement the requirements in Section III.A of Appendix I that conform with the guides of Appendix I to be shown by calculational procedures based on models and data such that the actual exposure of an individual through the appropriate pathways is unlikely to be substantially underestimated. The release rate specification for radioactive material in particulate form with half-lives greater than eight days (other than noble gases) and tritium are dependent on the existing radionuclide pathways to man in the areas at or beyond the site boundary. The pathways that were examined in the development of these calculations were: 1) individual inhalation of airborne radionuclides, 2) deposition of radionuclides onto green leafy vegetation with subsequent consumption by man, 3) deposition onto grassy areas where milk animals and meat producing animals graze with consumption of the milk and meat by man, and 4) deposition on the ground with subsequent exposure of man.

C. Gaseous Waste Treatment

The FUNCTIONALITY of the ventilation exhaust treatment systems ensures that the systems will be available for use whenever gaseous effluents require treatment prior to release to the environment. The requirement that appropriate portions of this system be used when specified provides assurance that the releases of radioactive materials in gaseous effluents will be kept as low as is reasonably achievable. This specification implements the requirements of 10 CFR Part 50.36a, General Design Criterion 60 of Appendix A to 10 CFR Part 50 and design objective and in Section II.D of Appendix I to 10 CFR Part 50. The specified limits governing the use of appropriate portions of the systems were specified to ensure the design objectives set forth in Section II.B and II.C of Appendix I, 10 CFR Part 50 for gaseous effluents are not exceeded.

D. Total Dose - Uranium Fuel Cycle

This specification is provided to meet the dose limitations of 40 CFR Part 190 that have been incorporated into 10 CFR Part 20.1301(d). This requires the preparation and submittal of a Special Report whenever the calculated doses due to releases of radioactivity and to radiation from uranium fuel cycle sources exceed 25 mRems to the total body or any organ, except the thyroid, which shall be limited to less than or equal to 75 mRems. It is highly unlikely that the resultant dose to a MEMBER OF THE PUBLIC will exceed the dose limits of 40 CFR Part 190 if the facility remains within twice the dose design objectives of Appendix I, 10 CFR Part 50, and if direct radiation doses (including outside storage tanks, etc.) are kept small. The Special Report shall describe a course of action that should result in the limitation of the annual dose to a MEMBER OF THE PUBLIC to within the 40 CFR Part 190 limits. For purposes of the Special Report, it may be assumed that the dose commitment to the MEMBER OF THE PUBLIC from other uranium fuel cycle sources is negligible, with the exception that dose contributions from other nuclear fuel cycle facilities at the same site or within a radius of 8 km must be considered. If the dose to any MEMBER OF THE PUBLIC is estimated to exceed the requirements of 40 CFR Part 190, the Special Report, with a request for a variance (provided the release conditions resulting in violation of 40 CFR Part 190 have not already been corrected), in accordance with the provisions of 40 CFR Part 190.11 and 10 CFR Part 20.2203(a)(4) and 20.2203(b) is considered to be a timely request and fulfills the requirements 40 CFR Part 190 until NRC staff action is completed. The variance only relates to the limits of 40 CFR Part 190, and does not apply in any way to the other requirements for dose limitation of 10 CFR Part 20. An individual is not considered a MEMBER OF THE PUBLIC during any period in which he/she is engaged in carrying out any operation that is part of the nuclear fuel cycle. Demonstration of compliance with the limits of 40 CFR Part 190 or with the design objectives of Appendix I to 10 CFR Part 50 will be considered to demonstrate compliance with the 0.1 rem limit of 10 CFR Part 20.1301.

7.3 Radiological Environmental Monitoring

7.3.1 Monitoring Program

The radiological environmental monitoring program required by this specification provides measurements of radiation and radioactive materials in those exposure pathways and for radionuclides which lead to the highest potential radiation exposures of individuals resulting from the station operation. This monitoring program thereby supplements the radiological effluent monitoring program by verifying that the measurable concentrations of radioactive materials and levels of radiation are not higher than expected on the basis of the effluent measurements and modeling of the environmental exposure pathways. The initially specified monitoring program was effective for at least the first three years of commercial operation. Following this period, program changes are initiated based on operational experience.

7.3.2 Land Use Survey

This specification is provided to ensure that changes in the use of unrestricted areas are identified and that modifications to the monitoring program are made if required by the results of this survey. The frequency of the Land Use Survey has been reduced to a biennial requirement in site procedures because persons knowledgeable in land use census monitor usage characteristics perform routine REMP sampling. This approach allows knowledge gained during sample collection to be integrated into the program, maintaining its effectiveness. The best survey information from door to door, aerial or consulting with local agricultural authorities, or equivalent, shall be used. This survey satisfies the requirements of Section IV.B.3 of Appendix I to 10 CFR Part 50. Restricting the survey to gardens of greater than 500 square feet provides assurance that significant exposure pathways via leafy vegetables will be identified and monitored since a garden of this size is the minimum required to produce the quantity (26 kg/year) of leafy vegetables assumed in Regulatory Guide 1.109 for consumption by a child. To determine this minimum garden size, the following assumptions were used, 1) that 20% of the garden was used for growing broad leaf vegetation (i.e., similar to lettuce and cabbage), and 2) a vegetation yield of 2 kg/m².

For milk, the survey is restricted to only milk animals (cow or goat) producing milk for human consumption. Air monitoring stations are strategically located to monitor the resident receptors who could potentially receive the highest doses from airborne radioactive material. For groundwater, samples shall be taken when sources are determined to potentially be affected by facility operations, and when sources are tapped for drinking or irrigation purposes in areas where the hydraulic gradient or recharge properties are suitable for contamination. Guidance provided in the Branch Technical Position and QATR Appendix E, E.3.1.3 is used to meet the intent of NUREG-1301.

7.3.3 Interlaboratory Comparison Program

The requirement for participation in an Interlaboratory Comparison Program is provided to ensure that independent checks on the precision and accuracy of the measurements of radioactive material in environmental sample matrices are performed as part of a quality assurance program for environmental monitoring in order to demonstrate that the results are reasonably valid for the purposes of Section IV.B.2 of Appendix I to 10 CFR Part 50.

7.4 Abnormal Release or Abnormal Discharge Reporting

7.4.1 Specific information should be reported concerning abnormal (airborne and/or liquid) releases on site and abnormal discharges to the unrestricted area. The report should describe each event in a way that would enable the NRC to adequately understand how the material was released and if there was a discharge to the unrestricted area. The report should describe the potential impact on the ingestion exposure pathway involving surface water and ground water, as applicable. The report should also describe the impact (if any) on other affected exposure pathways (e.g., inhalation from pond evaporation).

7.4.2 The following are the thresholds for reporting abnormal releases and abnormal discharges in the supplemental information section:

- A. Abnormal release or Abnormal Discharges that are voluntarily reported to local authorities under NEI 07-07, Industry Ground Water Protection Initiative. **[AR 39127]**
- B. Abnormal release or Abnormal discharges estimated to exceed 100 gallons of radioactive liquid where the presence of licensed radioactive material is positively identified (either in the on-site environs or in the source of the leak or spill) as greater than the minimum detectable activity for the laboratory instrumentation.
- C. Abnormal releases to on-site areas that result in detectable residual radioactivity after remediation.
- D. Abnormal releases that result in a high effluent radiation alarm without an anticipated trip occurring.
- E. Abnormal discharges to an unrestricted area.

7.4.3 Information on Abnormal releases or Abnormal discharges should include the following, as applicable:

- Date and duration
- Location
- Volume
- Estimated activity of each radionuclide
- Effluent monitoring results (if any)
- On-site monitoring results (is any)
- Depth to the local water table
- Classification(s) of subsurface aquifer(s) (e.g., drinking water, unfit for drinking water, not used for drinking water)
- Size and extent of any ground water plume
- Expected movement/mobility of any ground water plume
- Land use characteristics (e.g., water used for irrigation)
- Remedial actions considered or taken and results obtained
- Calculated member of the public dose attributable to the release
- Calculated member of the public dose attributable to the discharge
- Actions taken to prevent recurrence, as applicable
- Whether the NRC was notified, the date(s), and the contact organization

PART II
CALCULATIONS

1.0 EFFLUENT MONITOR SETPOINTS

1.1 Liquid Effluents

- 1.1.1 There is one liquid discharge pathway to the Missouri River. The pathway originates with the radioactive liquid waste processing system (monitor or hotel tanks). This pathway empties into the circulating water system which discharges to the Missouri River (see Figure 1). Figure 2 depicts the liquid discharge pathway and associated radiation monitor. Figure 3 depicts the methods of liquid effluent treatment.
- 1.1.2 The flowrate for dilution water varies with the number raw water pumps in service
- 1.1.3 QATR Appendix E, E.2.1.3.b establishes the administrative control limit on concentration of radioactive material, other than dissolved or entrained noble gases, released in liquid effluents to unrestricted areas conforming to ten times 10 CFR Part 20.1001-20.2401, Appendix B, Table 2, Column 2.
- 1.1.4 The liquid effluent monitoring instrumentation ALERT setpoints shall be established low enough to ensure that the concentration of radioactive material released in liquid effluents at site discharge will be less than the concentrations specified in 10 CFR Part 20, Appendix B, Table 2, Column 2.
- 1.1.5 The liquid effluent monitoring instrumentation HIGH ALARM setpoints shall be established low enough to ensure that the concentration of radioactive material released in liquid effluents at site discharge will be less than 10 times the concentrations specified in 10 CFR Part 20, Appendix B, Table 2, Column 2.
- 1.1.6 Cs-137 is used to calibrate the liquid effluent monitors.

1.1.7 Liquid Effluent Radiation Monitor

A. Overboard Discharge Header Monitor (RM-055)

1. This process radiation monitor provides control of the waste monitor tank effluent by monitoring the overboard header prior to its discharge into the circulating water discharge tunnel. The concentration of activity at discharge is controlled below ten times the 10 CFR Part 20 limit of $1.0E-06 \mu\text{Ci/ml}$ at site discharge for unidentified isotopes by the high alarm setpoint which closes the overboard flow control valve.
2. The following calculations for maximum concentration and alarm setpoints are valid for radioactive liquid releases of monitor tank discharge.
3. The maximum allowable concentration in the overboard discharge header is:

$$C_{MAX} = \frac{(1.0E - 05 \mu\text{Ci/ml}) (F)}{f}$$

Where:

- $1.0E-05 \mu\text{Ci/ml}$ = Ten times 10 CFR Part 20 Limit for unidentified radionuclides at site discharge (10 CFR Part 20, Appendix B, Note 2).
- F = Total dilution flow in the discharge tunnel (gpm). (Normal flow is based on 2 raw water pumps at 7,200 gpm total.)
- f = Maximum monitor tank discharge flow rate (gpm). (Normal monitor tank maximum flow is 15 gpm.)
- C_{MAX} = Maximum allowable activity in discharge header ($\mu\text{Ci/ml}$).

1.1.7A (continued)

The **High Alarm Setpoint** (CPM):

$$Setpoint = 0.75 \left[\left((K_3)(S_f)(C_{MAX}) \right) + B \right]$$

Where:

- 0.75 = An administrative correction factor which includes the following:
- 25% tolerance to account for the difference in detector sensitivity for the range of isotopes detected.
- S_f = Detector sensitivity factor (CPM/ μ Ci/ml). (Sensitivity based on Cs-137).
- K_3 = Allocation factor for Waste Liquid Releases (1)
- C_{MAX} = Maximum allowable concentration in discharge header (μ Ci/ml).
- B = Background (CPM)

The **Alert Setpoint** will be chosen less than or equal to one tenth (1/10) the value of the high alarm setpoint value so that significant increases in activity will be identified prior to exceeding an Unrestricted Area fractional sum of 1.0. It will also provide additional time for corrective actions prior to exceeding the Alarm Setpoint.

1.2 Airborne Effluents

1.2.1 There are multiple air effluent discharge pathways at the Fort Calhoun Station during decommissioning with three different mechanisms of release: Forced draft ventilation, Unventilated building release, and Open-air demolition.

- Forced draft ventilation uses installed or portable filtered ventilation units with a fan with a rated cfm as the release rate. Monitoring of forced draft ventilation includes utilizing presently installed system monitors such as RM-062, RM-052, and RM-043. When portable ventilation systems are used, the air particulate sample head shall directly sample the airborne effluent discharge flowpath.
- Unventilated building releases in which the dimension of an open doorway coupled with windspeed blowing through the doorway are used to calculate the release rate. Unventilated building releases shall be monitored with a portable air sampler located outside of the doorway at any time the door is open, and active decommissioning that could generate airborne is in progress.
- Open-air demolition releases are rubble and building debris containing low level radioactive material may be wind-blown as a release. Other Open-air releases may include building demolition in which the structure of the building is demolished to the point where it becomes inaccurate to use doorway area as a release point each location shall be documented as they are established. Airborne effluent monitoring during Open-air demolition shall be accomplished by placing 4 air samplers in 4 general opposing directions around the area to be sampled, placed in areas that will not obstruct decommissioning activities around the area.

Table 1 - Deleted

Figure 1 - Exclusion and Site Boundary Map

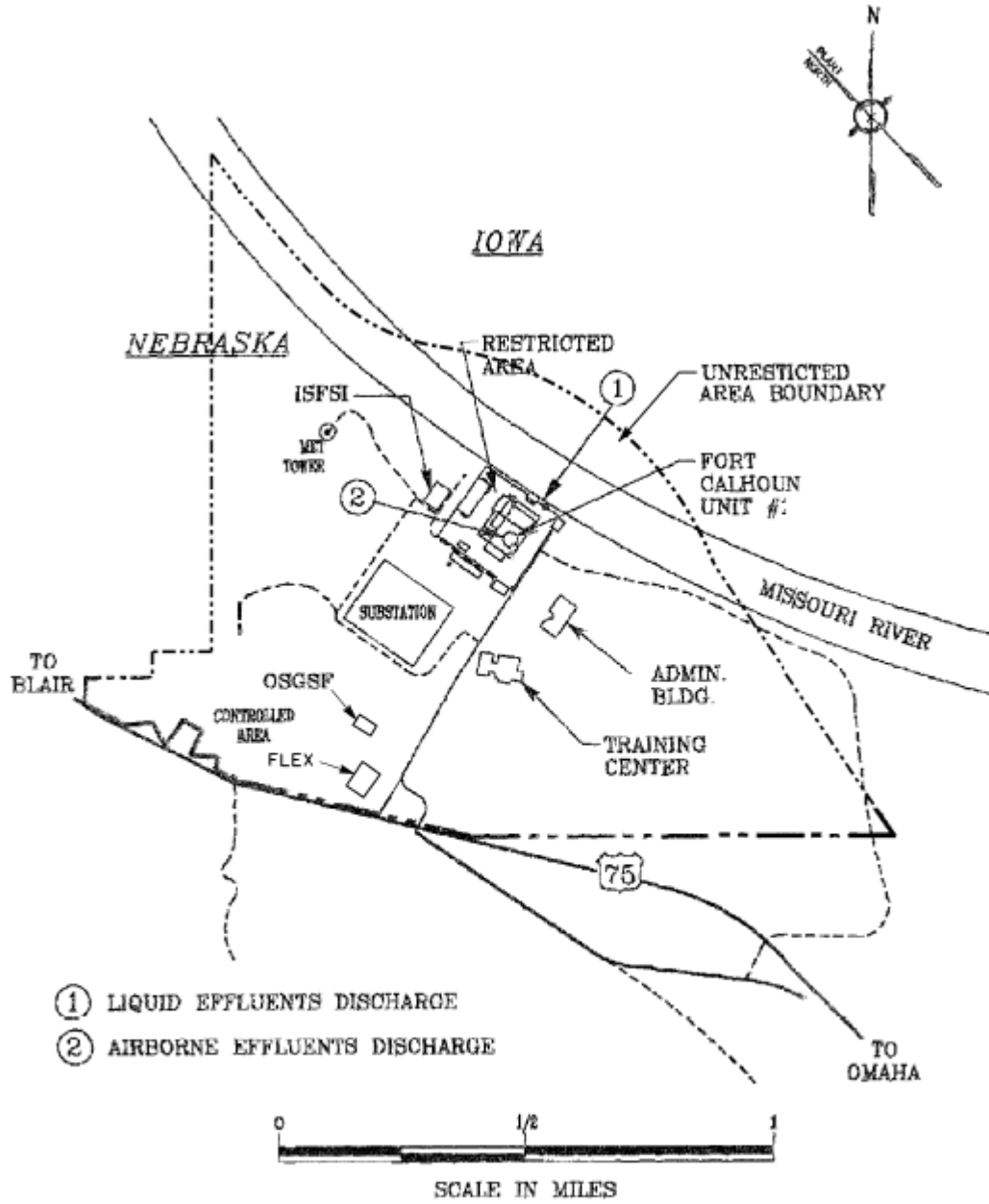

SITE BOUNDARY MAP

DRAWING FILE NO.
P-00414

Figure 2 - Liquid Radioactive Discharge Pathways

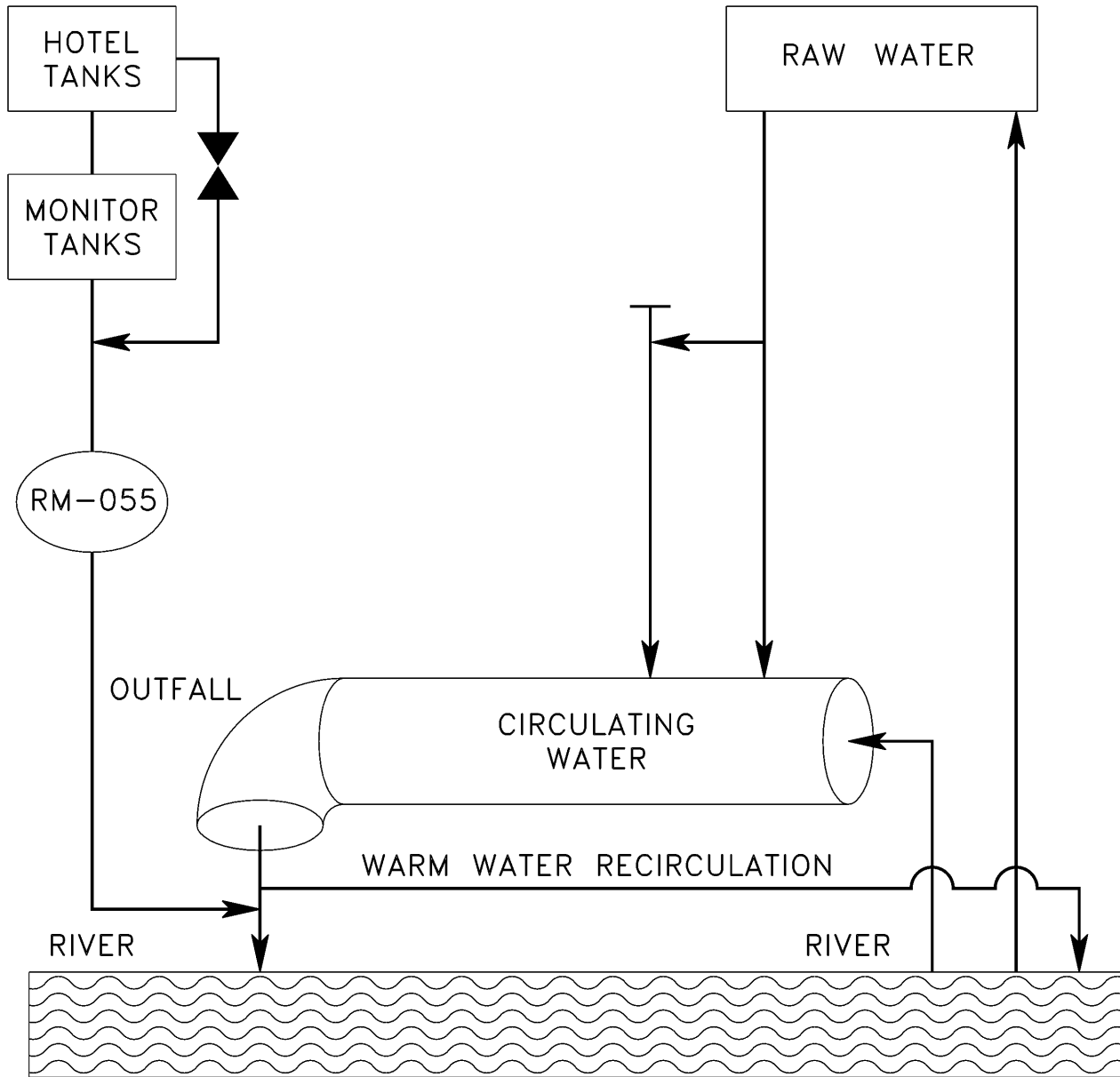

LIQUID RADIOACTIVE DISCHARGE PATHWAYS

DRAWING FILE NO.
P-00410

Figure 3 - Liquid Radioactive Waste Disposal System

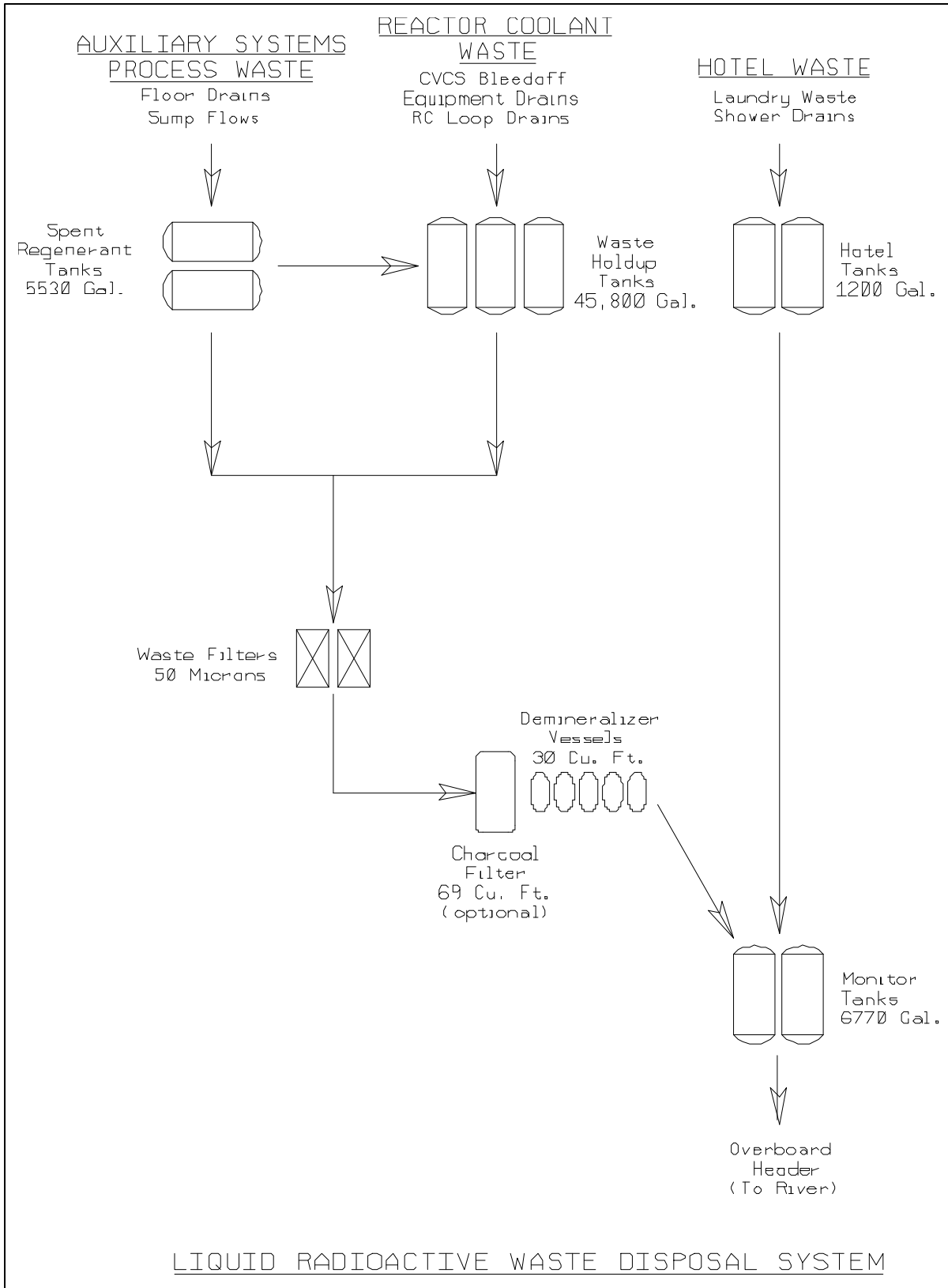
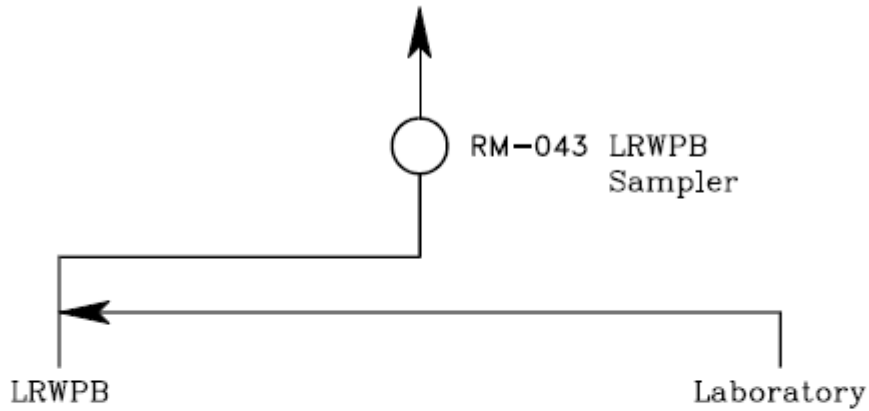
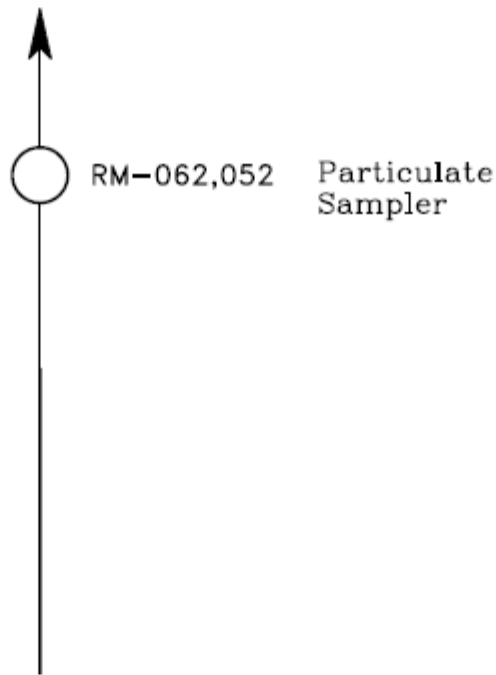

Figure 4 - Airborne Effluent Discharge Pathways



LABORATORY AND RADIOACTIVE WASTE PROCESSING BUILDING



AUXILIARY BUILDING EXHAUST STACK

Auxiliary Building Ventilation

AIRBORNE EFFLUENT DISCHARGE PATHWAYS

DRAWING FILE NO.
P-00411

Figure 4 - Airborne Effluent Discharge Pathways (continued)

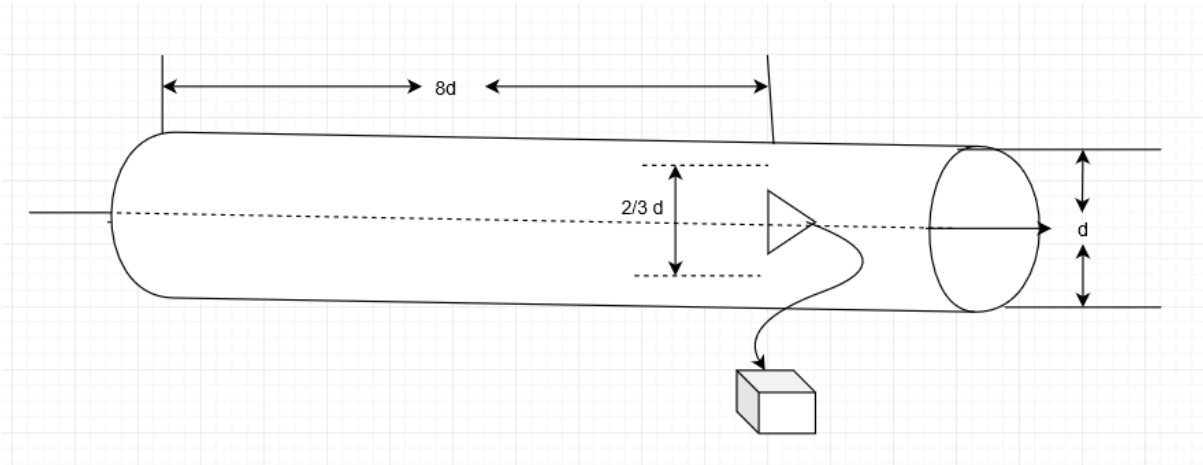

FORCED DRAFT AIR SAMPLER WITH EXHAUST TRUNK DISCHARGE

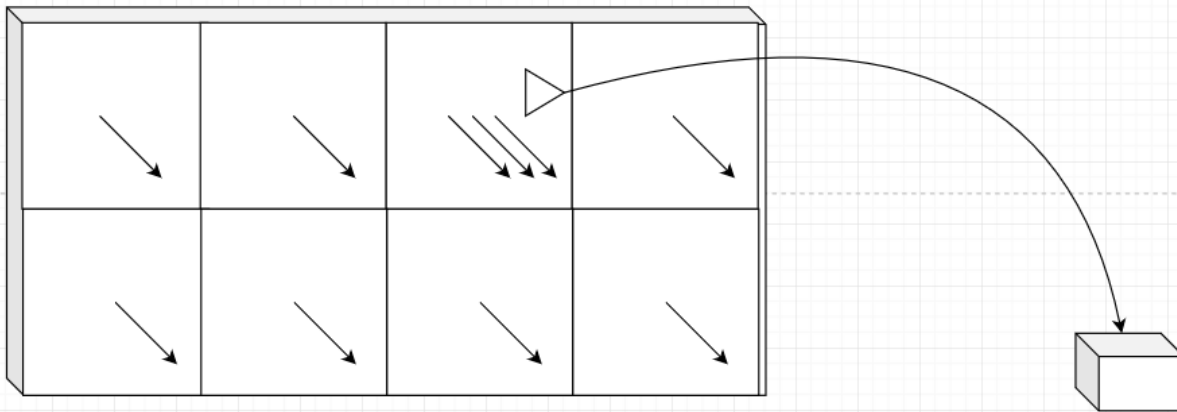

FORCED DRAFT AIR SAMPLER WITH OUTLET PLENUM

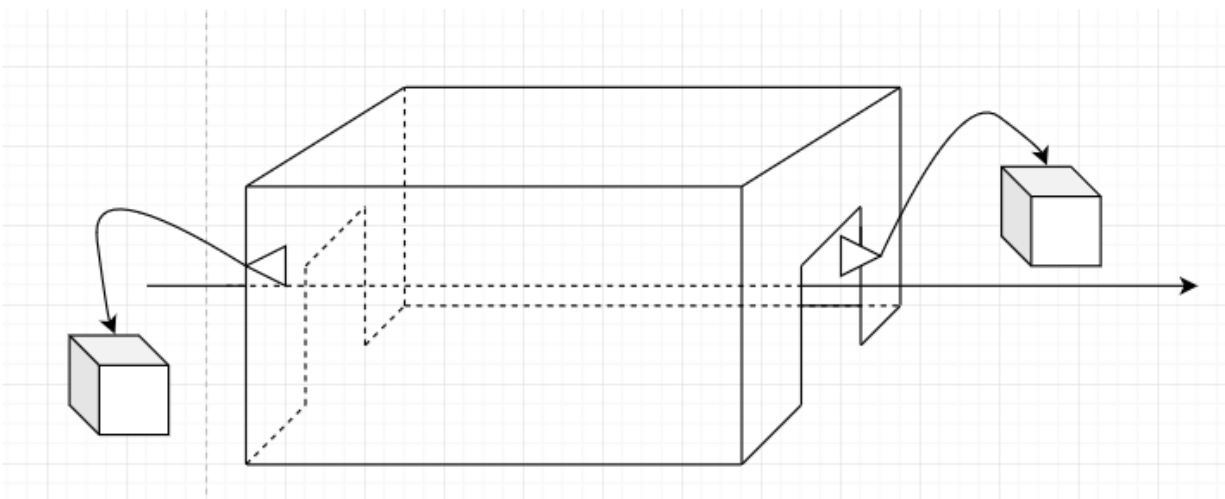

UNVENTILATED BUILDING RELEASE AIR SAMPLERS

Figure 4 - Airborne Effluent Discharge Pathways (continued)

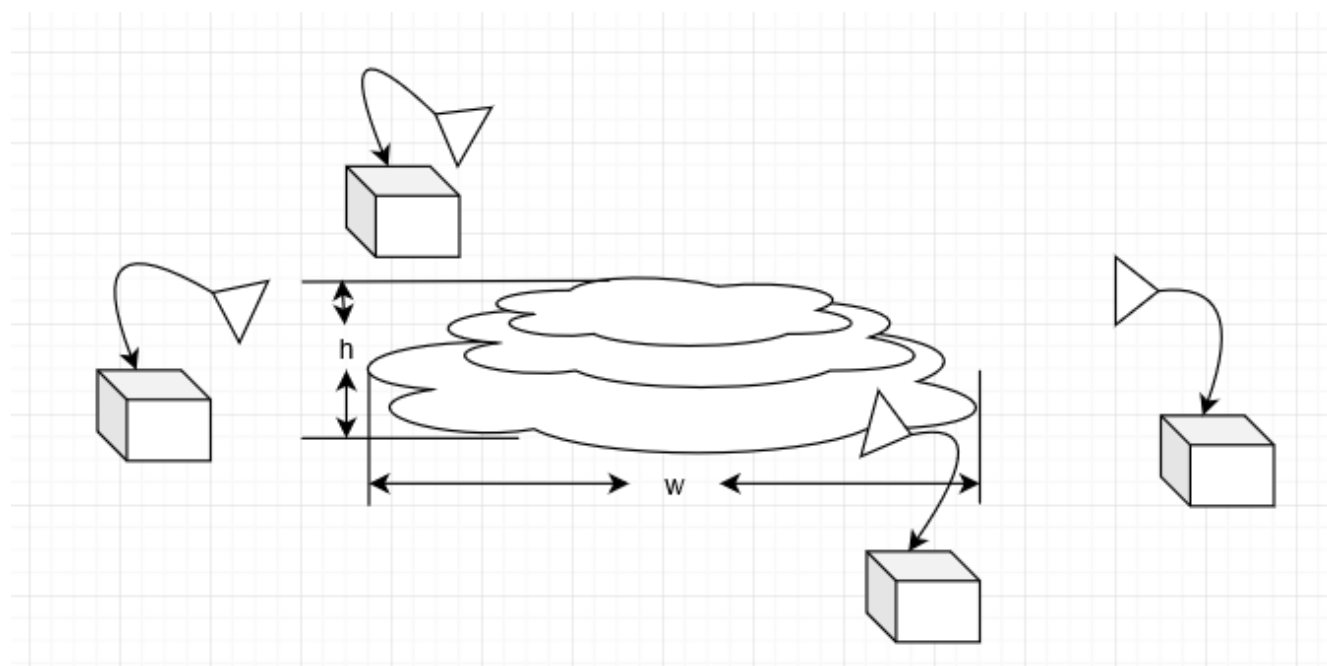

OPEN-AIR DEMOLITION AIR SAMPLERS

Figure 5 - Airborne Radioactive Waste Disposal System

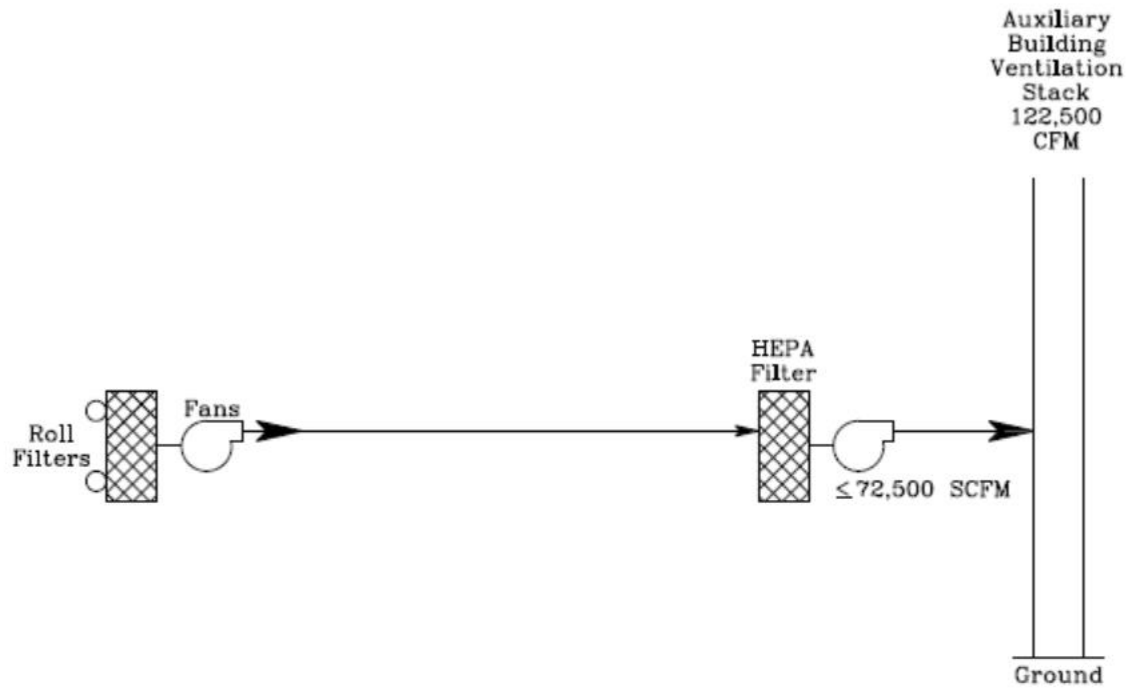

AIRBORNE RADIOACTIVE WASTE DISPOSAL SYSTEM

DRAWING FILE NO.
P-00412

2.0 EFFLUENT CONCENTRATIONS**2.1 Liquid Effluent Concentrations**

2.1.1 The concentration of radioactive material in liquid effluents (after dilution in the Circulating Water System) will be limited to the concentrations as specified in 10 CFR Part 20, Appendix B, Table 2, Column 2. For batch releases (Monitor and Hotel Waste Tanks) the analyses will be performed in accordance with Part I, Table 4.1, of the Off-Site Dose Calculation Manual, and the concentration of each radionuclide at site discharge will be calculated, based on the following equation:

$$A_i = \frac{a_i f}{F + f}$$

$$\text{and } \sum_{i=1}^n \frac{A_i}{wec_i} \leq 1$$

Radionuclide concentration at site discharge:

Where:

A_i = concentration at site discharge for radionuclide (I), in $\mu\text{Ci/ml}$.

a_i = concentration of radionuclide (I) in the undiluted effluent, in $\mu\text{Ci/ml}$.

f = undiluted effluent flowrate, in gpm.

F = total diluted effluent flowrate in gpm.

wec_i = water effluent concentration limit for radionuclide (I) per 10 CFR Part 20, Appendix B, Table 2, Column 2.

i	NOTE	i
	In addition to the above defined method, Notes 1 through 4 of 10 CFR Part 20, Appendix B, will also be applicable.	

2.2 Airborne Effluent Concentrations

2.2.1 The concentration at the unrestricted area boundary, due to airborne effluent releases, will be limited to less than Appendix B, Table 2, Column 1, values.

2.2.2 To determine the concentration and air effluent concentration (aec) fraction summation at the unrestricted area boundary, the following equations will be used:

$$A_i = K_0 Q_i (\chi/Q)$$

$$\text{and } \sum_{i=1}^n \frac{A_i}{ECL_i} \leq 1$$

Where:

A_i = Concentration of radionuclide (I) at the unrestricted area boundary

K_0 = Constant of unit conversion. (1.0E-6 m3/cc)

ECL_i = Effluent concentration limit (10 CFR Part 20, Appendix B, Table 2, Column 1 value for radionuclide(I))

Q_i = The release rate of radionuclide (I) in airborne effluents from all vent releases (in $\mu\text{Ci}/\text{sec.}$)

(χ/Q) = Annual Average Dispersion Factor at the Unrestricted Area Boundary from Part II, Table 4, of the Off-Site Dose Calculation Manual.

2.2.3 As appropriate, simultaneous releases from all release pathways will be considered in evaluating compliance with the release rate limits of 10 CFR Part 20. Historical annual average dispersion parameters, as presented in Table 4, may be used for evaluating the airborne effluent dose rate.

3.0 RADIOACTIVE EFFLUENT DOSE CALCULATIONS

3.1 Liquid Effluent Dose Calculations

3.1.1 Three pathways for human exposure to liquid releases from FCS to the Missouri River exists: 1) fish, 2) drinking water, and 3) Shoreline deposition. Fish are considered to be taken from the vicinity of the facility discharge. The drinking water for Omaha is located 19 miles downstream from FCS. The dilution factors for these pathways are derived from the Revised Environmental Report for FCS, (1974), (page 4-29 and 4-31). This report states that during Low-Low river conditions, the concentration at Omaha's water intake will be $\leq 14\%$ of the concentration at discharge from FCS and will average 3%. This equates to a dilution factor of 7.14, which is used to calculate the maximum dose to an individual from liquid pathways and a dilution factor of 33.33, for calculating the average dose. All pathways combine to give the dose to an individual in unrestricted areas.

3.1.2 10 CFR Part 50, Appendix I restricts the dose to individuals in the unrestricted areas from radioactive materials in liquid effluents from the Fort Calhoun Station to the following limits:

- during any calendar quarter
 - ≤ 1.5 mrem to total body
 - ≤ 5.0 mrem to any organ

and

- during any calendar year
 - ≤ 3.0 mrem to total body
 - ≤ 10.0 mrem to any organ

The following calculational methods shall be used for determining the dose or dose commitment from liquid effluents.

3.1.3 Doses from Liquid Effluent Pathways

A. Potable Water

$$R_{apj} = 1100 \frac{U_{ap} M_p}{F} \sum_{i=1}^n Q_i D_{aipj} \exp(-\lambda_i t_p)$$

Where:

R_{apj} = is the total annual dose to organ(j) of individuals of age group (a) from all of the radionuclides (I) in pathway (p), in mrem/yr.

U_{ap} = is a usage factor that specifies the intake rate for an individual of age group (a) associated with pathway (p), in ℓ/yr . (Table 6)

M_p = is the mixing ratio (reciprocal of the dilution factor) at the point of withdrawal of drinking water, dimensionless. (Table 17)

F = is the flow rate of the liquid effluent, in ft^3/sec .

Q_i = is the annual release rate of radionuclide (I), in Ci/yr.

D_{aipj} = is the dose factor specific to a given age group (a), radionuclide (I), pathway (p), and organ (j) which can be used to calculate the radiation dose from an intake of a radionuclide, in mrem/pCi. (Tables 13-16)

λ_i = is the radiological decay constant of radionuclide (I), in hr^{-1} .

t_p = is the average transit time required for radionuclides to reach the point of exposure. For internal dose, t_p is the total time elapsed between release of the radionuclides and ingestion of water, in hours. (Table 17)

1100 = Constant ($\text{pCi} \cdot \text{yr} \cdot \text{ft}^3/\text{Ci} \cdot \text{sec} \cdot \text{L}$)

3.1.3 (continued)

B. Aquatic Foods

$$R_{apj} = 1100 \frac{U_{ap} M_p}{F} \sum_{i=1}^n Q_i B_{ip} D_{aipj} \exp(-\lambda_i t_p)$$

Where:

- R_{apj} = is the total annual dose to organ (j) of individuals of age group (a) from all of the radionuclides (I) in pathway (p), in mrem/yr.
- U_{ap} = is a usage factor that specifies the intake rate for an individual of age group (a) associated with pathway (p), in kg/yr. (Table 6)
- M_p = is the mixing ratio (reciprocal of the dilution factor) at the point of harvest of aquatic food, dimensionless. (Table 17)
- F = is the flow rate of the liquid effluent, in ft³/sec.
- Q_i = is the annual release rate of radionuclide (I), in Ci/yr.
- B_{ip} = is the equilibrium bioaccumulation factor for radionuclide (I) in pathway (p) expressed as the ratio of the concentration in biota (in pCi/kg) to the radionuclide concentration in water (in pCi/liter), in (pCi/kg)/(pCi/liter). (Table 3)
- D_{aipj} = is the dose factor specific to a given age group (a), radionuclide (I), pathway (p), and organ (j), which can be used to calculate the radiation dose from an intake of a radionuclide, in mrem/pCi. (Tables 13-16)
- λ_i = is the radiological decay constant of radionuclide (I), in hr⁻¹.
- t_p = is the average transit time required for radionuclides to reach the point of exposure. For internal dose, t_p is the total time elapsed between release of the radionuclides and ingestion of food, in hours. (Table 17)
- 1100 = Constant (pCi * yr * ft³/Ci * sec * L)

3.1.3 (continued)

C. Shoreline Deposits

$$R_{apj} = 110,000 \frac{U_{ap} M_p W}{F} \sum_{i=1}^n Q_i T_{ip} D_{aipj} [\exp(-\lambda_i t_p)] [1 - \exp(-\lambda_i t_b)]$$

Where:

- R_{apj} = is the total annual dose to organ (j) of individuals of age group (a) from all of the radionuclides (I) in pathway (p), in mrem/yr.
- U_{ap} = is a usage factor that specifies the exposure time for an individual of age group (a) associated with pathway (p), in hr/yr. (Table 6)
- M_p = is the mixing ratio (reciprocal of the dilution factor) at the point of exposure, dimensionless. (Table 17)
- W = is the shore-width factor, dimensionless. (Table 17)
- F = is the flow rate of the liquid effluent, in ft³/sec.
- Q_i = is the annual release rate of radionuclide (I), in Ci/yr.
- T_{ip} = is the radioactive half life of radionuclide (I), in days.
- D_{aipj} = is the dose factor specific radionuclide (I) which can be used to calculate the radiation dose from exposure to a given concentration of a radionuclide in sediment, expressed as a ratio of the dose rate (in mrem/hr) and the real radionuclide concentration (in pCi/m²). (Table 8)
- λ_i = is the radiological decay constant of radionuclide (I), in hr⁻¹.
- t_p = is the average transit time required for radionuclides to reach the point of exposure, in hours. (Table 17)
- t_b = is the period of time for which sediment or soil is exposed to the contaminated water, in hours. (Table 17)

$$110,000 = \text{Constant} [(100 * \text{pCi} * \text{yr} * \text{ft}^3) / (\text{Ci} * \text{sec} * \text{L})]$$

3.2 Airborne Effluent Dose Calculations

3.2.1 Radioiodine, Tritium, and Particulates

10 CFR Part 50, Appendix I, restricts the dose to individuals in the unrestricted areas from radioactive materials in gaseous airborne from the Fort Calhoun Station to:

- During any calendar quarter
 ≤ 7.5 mrem to any organ

and

- During any calendar year
 ≤ 15 mrem to any organ

The dose to an individual from radioiodines, radioactive materials in particulate form, and radionuclides other than noble gases with half-lives greater than 8 days in airborne effluents released to unrestricted areas should be determined by the following expressions:

i	NOTE	i
	In all cases, for releases of tritium, use the dispersion parameter for inhalation (χ/Q).	

A. Annual Organ Dose from External Irradiation from Radioactivity Deposited on the Ground Plane

The ground plane concentration of radionuclide (I) at distance r , in the sector at angle θ , with respect to the release point, may be determined by:

$$C_i^G(r, \theta) = \frac{[1.0 \times 10^{12}][\delta_i(r, \theta)Q_i]}{\lambda_i} [1 - \exp(-\lambda_i t_b)]$$

Where:

- C_i^G = is the ground plane concentration of the radionuclide (I) at distance r , in the sector at angle θ , from the release point, in pCi/m².
- Q_i = is the annual release rate of radionuclide (I) to the atmosphere, in Ci/yr.
- t_b = is the time period over which the accumulation is evaluated, which is assumed to be 20 years (mid-point of plant operating life). (Table 17)
- $\delta_i(r, \theta)$ = is the annual average relative deposition of radionuclide (I) at distance r , in the sector at angle θ , considering depletion of the plume by deposition during transport, in m⁻². Table 4
- λ_i = is the radiological decay constant for radionuclide (I), in yr⁻¹.
- 1.0×10^{12} = is the number of pCi/Ci

The annual organ dose is then calculated using the following equation:

$$D_i^G(r, \theta) = 8760 S_f \sum_{i=1}^n C_i^G(r, \theta) DFG_{ij}$$

Where:

- $C_i^G(r, \theta)$ = is the ground plane concentration of radionuclide (i) at distance r, in the sector at angle θ , in pCi/m².
- DFG_{ij} = is the open field ground plane dose conversion factor for organ (j) from radionuclide (i), in mrem-m²/pCi-hr. (Table 8)
- $D_j^G(r, \theta)$ = is the annual dose to the organ (j) at distance r, in the sector at angle θ , in mrem/yr.
- S_f = is the shielding factor that accounts for the dose reduction due to shielding provided by residential structures during occupancy, dimensionless. (Table 17)
- 8760 = is the number of hours in a year

B. Annual Dose from Inhalation of Radionuclides in Air

The annual average airborne concentration of radionuclide (i) at distance r, in the sector at angle θ , with respect to the release point, may be determined as:

$$X_i(r, \theta) = 3.17 \times 10^4 Q_i [\chi/Q]^D(r, \theta)$$

Where:

- Q_i = is the annual release rate of radionuclide (i) to the atmosphere, in Ci/yr.
- $\chi_i(r, \theta)$ = is the annual average ground-level concentration of radionuclide (i) in air at distance r, in the sector at angle θ , in pCi/m³.
- $[\chi/Q]^D(r, \theta)$ = is the annual average atmosphere dispersion factor, in sec/m³ (see Reg Guide 1.111). This includes depletion (for radioiodines and particulates) and radiological decay of the plume. (Table 4)
- 3.17×10^4 = is the number of pCi/Ci divided by the number of sec/yr.

The annual dose associated with inhalation of all radionuclides to organ (j) of an individual in age group (a), is then:

$$D_{ja}^A(r, \theta) = R_a \sum_{i=1}^n X_i(r, \theta) DFA_{ija}$$

Where:

- $D_{ja}^A(r, \theta)$ = is the annual dose to organ (j) of an individual in the age group (a) at distance r, in the sector at angle θ , due to inhalation, in mrem/yr.
- R_a = is the annual air intake for individuals in the age group (a), in m³/yr. (Table 6)
- $X_i(r, \theta)$ = is the annual average ground-level concentration of radionuclide (i) in air at distance r, in the sector at angle θ , in pCi/m³.
- DFA_{ija} = is the inhalation dose factor for radionuclide (i), organ (j), and age group (a), in mrem/pCi. (Tables 9-12)

3.2.2 Concentrations of Radionuclides in Foods and Vegetation from Atmospheric Releases

A. Parameters for Calculating Concentrations in Forage, Produce, and Leafy Vegetables, excluding Tritium

$$C_i^V(r, \theta) = d_i(r, \theta) \left[\frac{r[1 - \exp(-\lambda_{Ei}t_e)]}{Y_v\lambda_{Ei}} + \frac{B_{iv}[1 - \exp(-\lambda_i t_b)]}{P\lambda_i} \right] \exp(-\lambda_i t_h)$$

Where:

- $C_i^V(r, \theta)$ = is the concentration of radionuclide (i) in and on vegetation at distance r, in the sector at angle θ , in pCi/kg.
- $d_i(r, \theta)$ = is the deposition rate of radionuclide (i) at distance r, in the sector at angle θ , in pCi/m² hr.
- r = is the fraction of deposited activity retained on crops, dimensionless. (Table 17)
- λ_{Ei} = is the effective removal rate constant for radionuclide (i) from crops, in hr⁻¹.
 $\lambda_{Ei} = \lambda_i + \lambda_w$
 $\lambda_w = 0.0021/\text{hr}$. (Table 17)
- t_e = is the time period that crops are exposed to contamination during the growing season, in hours. (Table 17)
- Y_v = is the agricultural productivity (yield) in kg (wet weight)/m². (Table 17)
- B_{iv} = is the concentration factor for uptake of radionuclide (i) from soil by edible parts of crops, in pCi/ kg (wet weight) per pCi/kg dry soil. (Table 5)
- λ_i = is the radiological decay constant of radionuclide (i), in hr⁻¹
- t_b = is the period of time for which sediment or soil is exposed to the contaminated water, in hours (mid-point of plant life). (Table 17)
- P = is the effective "surface density" for soil, in kg (dry soil)/m². (Table 17)
- t_h = is the holdup time that represents the time interval between harvest and consumption of the food, in hours. (Table 17)

Different values for the parameters t_e , Y_v , and t_h , may be used to allow the use of the Equation for different purposes: estimating concentrations in produce consumed by man; in leafy vegetables consumed by man; in forage consumed directly as pasture grass by dairy cows, beef cattle, or goats; and in forage consumed as stored feed by dairy cows, beef cattle or goats. See Table 17.

The deposition rate from the plume is defined by (Reg. Guide 1.109, Rev. 1, Page 1.109-26, Equa. C-6):

$$d_i(r, \theta) = 1.1 \times 10^8 \delta_i(r, \theta) Q_i$$

Where:

$d_i(r, \theta)$ = is the deposition rate of radionuclide (i).

$\delta_i(r, \theta)$ = is the relative deposition of radionuclide (i), considering depletion and decay, in m^{-2} (see Reg Guide 1.111). (Table 4)

1.1×10^8 = is the number of pCi/Ci (10^{12}) divided by the number of hours per year (8760).

Q_i = is the annual release rate of radionuclide (i) to the atmosphere, in Ci/yr.

- B. For radioiodines, the model considers only the elemental fraction of the effluent:

$$d_i(r, \theta) = 3.3 \times 10^7 \delta_i(r, \theta) Q_i$$

Where:

- $d_i(r, \theta)$ = The deposition rate of radioiodine (i).
- 3.3×10^7 = The number of pCi/Ci (1012) divided by the number of hours per year (8760), then multiplied by the amount of radioiodine emissions considered to be elemental (0.5).
- $\delta_i(r, \theta)$ = The relative deposition of radioiodine (i), considering depletion and decay, in m⁻². (Table 4)
- Q_i = The total (elemental and nonelemental) radioiodine (i) emission rate.

- C. Parameters for Calculating the Concentration of Radionuclide (i) in the Animal's Feed (Milk Cow, Beef Cow, and Goat)

$$C_i^V(r, \theta) = f_p f_s C_i^P(r, \theta) + (1 - f_p) C_i^S(r, \theta) + f_p (1 - f_s) C_i^S(r, \theta)$$

Where:

- $C_i^V(r, \theta)$ = is the concentration of radionuclide (i) in the animal's feed, in pCi/kg.
- $C_i^P(r, \theta)$ = is the concentration of radionuclide (i) on pasture grass (calculated using Equation 3.2.3A with $t_h=0$), in pCi/kg.
- $C_i^S(r, \theta)$ = is the concentration of radionuclide (i) in stored feeds (calculated using Equation 3.2.3A with $t_h=90$ days), in pCi/kg.
- f_p = is the fraction of the year that animals graze on pasture. (Table 17)
- f_s = is the fraction of daily feed that is pasture grass while the animal grazes on pasture. (Table 17)

3.2.3 Parameters for Calculating Radionuclide Concentration in Cow and Goat Milk

$$C_i^M(r, \theta) = F_m C_i^V(r, \theta) Q_F \exp(-\lambda_i t_f)$$

Where:

$C_i^M(r, \theta)$ = is the concentration of radionuclide (i) in milk, in pCi/liter.

$C_i^V(r, \theta)$ = is the concentration of radionuclide (i) in the animal's feed, in pCi/kg.

F_m = is the average fraction of the animal's daily intake of radionuclide (i) which appears in each liter of milk, in days/liter. (Table 5)

Q_F = is the amount of feed consumed by the animal per day, in kg/day. (Table 7)

t_f = is the average transport time of the radionuclide (i) from the feed to the milk and to the receptor (a value of 2 days is assumed). (Table 17)

λ_i = is the radiological decay constant of radionuclide (i), in days⁻¹.

3.2.4 Parameters for Calculating Radionuclide Concentration in Cow Meat, excluding Tritium

$$C_i^F(r, \theta) = F_f C_i^V(r, \theta) Q_F \exp(-\lambda_i t_s)$$

Where:

$C_i^F(r, \theta)$ = is the concentration of radionuclide (i) in meat, in pCi/liter.

$C_i^V(r, \theta)$ = is the concentration of radionuclide (i) in the animal's feed, in pCi/kg.

Q_F = is the amount of feed consumed by the animal per day, in kg/day. (Table 7)

F_f = is the average fraction of the animal's daily intake of radionuclide (i) which appears in each kilogram of flesh, in days/kilogram. (Table 5)

t_s = is the average time from slaughter to consumption. (Table 17)

3.2.5 Parameters for Calculating Tritium Concentrations in Vegetation

The concentration of tritium in vegetation is calculated from its concentration in the air surrounding the vegetation.

$$C_T^V(r, \theta) = 3.17 \times 10^7 Q_T \frac{[\chi/Q](r, \theta)(0.75)(0.5)}{H} = 1.2 \times 10^7 Q_T \frac{[\chi/Q](r, \theta)}{H}$$

Where:

$C_T^V(r, \theta)$ = is the concentration of tritium in vegetation grown at distance r, in the sector at angle θ , in pCi/kg.

H = is the absolute humidity of the atmosphere at distance r, in the sector at angle θ , in g/m³. H=8 gm/kg.

Q_T = is the annual release rate of tritium, in Ci/yr.

$[\chi/Q](r, \theta)$ = is the atmospheric dispersion factor, in sec/m³. (Table 4)

0.5 = is the ratio of tritium concentration in facility water to tritium concentration in atmospheric water, dimensionless.

0.75 = is the fraction of total facility mass that is water, dimensionless.

3.2.6 Annual Dose from Atmospherically Released Radionuclides in Foods

- A. The total annual dose to organ (j) of an individual in age group (a) resulting from ingestion of all radionuclides in produce, milk, and leafy vegetables is given by:

$$D_{ja}^D(r, \theta) = \sum_i DFI_{ija} [U_a^V f_g C_i^V(r, \theta) + U_a^M C_i^M(r, \theta) + U_a^F C_i^F(r, \theta) + U_a^L f_\ell C_i^L(r, \theta)]$$

Where:

- $D_{ja}^D(r, \theta)$ = is the annual dose to organ (j) of an individual in age group (a) from dietary intake of atmospherically released radionuclides, in mrem/yr.
- DFI_{ija} = is the dose conversion factor for the ingestion of radionuclide (i), organ (j), and age group (a), in mrem/pCi. Tables 13-16.
- U_a^V = are the ingestion rates of produce (non-leafy vegetables, fruits, and grains), respectively for individuals in age group (a). (Table 6)
- U_a^M = is the ingestion rate of cow milk for individuals in age group (a), in P/yr. (Table 6)
- U_a^F = is the ingestion rate of meat for individuals in age group (a), in kg/yr. (Table 6)
- U_a^L = are the ingestion rates of leafy vegetables for individuals in age group (a), in kg/yr. (Table 6)
- $C_i^V(r, \theta)$ = is the concentration of radionuclide (i) in the animal's feed, in pCi/kg.
- $C_i^M(r, \theta)$ = is the concentration of radionuclide (i) in milk, in pCi/liter.
- $C_i^F(r, \theta)$ = is the concentration of radionuclide (i) in meat, in pCi/liter.
- $C_i^L(r, \theta)$ = is the concentration of radionuclide (i) in and on leafy vegetation, in pCi/kg.
- f_g = Fraction of ingested produce grown in garden of interest (Table 17)
- f_ℓ = Fraction of leafy vegetables grown in garden of interest (Table 17)

B. Calculating the Ingested Dose from Leafy and Non-Leafy (produce) Vegetation for Radionuclide (i) to Each Organ (j) and Age Group (a)

$$D_{ja}^D(r, \theta) = DFI_{ija} [U_a^L f_l C_i^L(r, \theta) + U_a^V f_g C_i^V(r, \theta)]$$

Where:

$D_{ja}^D(r, \theta)$ = is the annual dose from the ingestion of radionuclide (i) to organ (j) of an individual in age group (a) from dietary intake of atmospherically released radionuclides in vegetation, in mrem/yr.

DFI_{ija} = is the dose conversion factor for the ingestion of radionuclide (i), organ (j), and age group (a), in mrem/pci. Tables 13-16

U_a^L, U_a^V = are the ingestion rates of leafy vegetables and produce (non-leafy vegetables, fruits, and grains), for individuals in age group (a), in kg/yr. (Table 6)

C_i^L = is the concentration of radionuclide (i) in and on leafy vegetation, in pCi/kg.

C_i^V = is the concentration of radionuclide (i) in and on produce, in pCi/kg.

f_g = Fraction of ingested produce grown in garden of interest (Table 17)

f_l = Fraction of leafy vegetables grown in garden of interest (Table 17)

C. Calculation Determining the Ingested Dose from Cow Milk for Radionuclide (i), Organ (j), and Age Group (a)

$$D_{ja}^D(r, \theta) = DFI_{ija} [U_a^M C_i^M(r, \theta)]$$

Where:

$D_{ja}^D(r, \theta)$ = is the annual dose from the ingestion of radionuclide (i), organ (j) of an individual in age group (a) from dietary intake of atmospherically released radionuclides in cow milk, in mrem/yr.

DFI_{ija} = is the dose conversion factor for the ingestion of radionuclide (i), organ (j), and age group (a), in mrem/pCi. (Tables 13-16)

U_a^M = is the ingestion rate of cow milk for individuals in age group (a), in P/yr. (Table 6)

C_i^M = is the radionuclide concentration in cow milk, in pCi/kg.
Equation 3.2.4

D. Calculation Determining the Ingested Dose from Meat for Radionuclide (i) to Organ (j) and Age Group (a)

$$D_{ja}^D(r, \theta) = DFI_{ija} [U_a^F C_i^F(r, \theta)]$$

Where:

$D_{ja}^D(r, \theta)$ = is the annual dose from the ingestion of radionuclide (i), organ (j) of an individual in age group (a) from dietary intake of atmospherically released radionuclides in meat, in mrem/yr.

DFI_{ija} = is the dose conversion factor for the ingestion of radionuclide (i), organ (j), and age group (a), in mrem/pCi. (Tables 13-16)

U_a^F = is the ingestion rate of meat for individuals in age group (a), in kg/yr. (Table 6)

C_i^F = is the radionuclide (i) concentration in meat, in pCi/kg.

4.0 LOWER LIMIT OF DETECTION (LLD)

4.1 The lower limit of detection (LLD) for liquid and airborne effluent discharges and environmental samples referenced in Part I, Tables 4.1, 4.2 and 5.3, of the Off-Site Dose Calculation Manual, is defined as the smallest concentration of radioactive material in a sample that will yield a net count, above system background, that will be detected with 95 percent probability with only 5 percent probability of falsely concluding that a blank observation represents a "real" signal.

4.2 For a particular measurement system, which may include radiochemical separation:

$$LLD = \frac{4.66 * S_b}{E * V * D * Y * \exp(-\lambda\Delta t)}$$

Where:

LLD = the lower limit of detection as defined above, in either picoCuries or microCuries, per unit mass or volume as a function of the value of D

S_b = the standard deviation of the background counting rate or of the counting rate of a blank sample, as appropriate, as counts per minute

E = the counting efficiency, as counts per disintegration

V = the sample size in units of mass or volume

D = 2.22E+06 of disintegrations per minute per microCurie or 2.22 disintegrations per minute per picoCurie

Y = the fractional radiochemical yield, when applicable

λ = the radioactive decay constant for the particular radionuclide

Δt = the elapsed time between the midpoint of sample collection and time of counting

Appropriate values of E, V, Y, and Δt should be used in the calculation.

4.3 It should be recognized that the LLD is defined as an A Priori limit representing the capability of a measurement system and not as a limit for a particular measurement.

4.4 LLD verifications will be performed on a periodic basis. This determination is to ensure that the counting system is able to detect levels of radiation at the LLD values for the specific type of analysis required. They will be performed with a blank (non-radioactive) sample in the same counting geometry as the actual sample.

Table 2 - Deleted

Table 3 - Bioaccumulation Factors
(pCi/kg per pCi/liter)

FRESHWATER

Element	Fish	Invertebrate
H	9.0E-01	9.0E-01
C	4.6E+03	9.1E+03
Na	1.0E+02	2.0E+02
P	1.0E+05	2.0E+04
Cr	2.0E+02	2.0E+03
Mn	4.0E+02	9.0E+04
Fe	1.0E+02	3.2E+03
Co	5.0E+01	2.0E+02
Ni	1.0E+02	1.0E+02
Cu	5.0E+01	4.0E+02
Zn	2.0E+03	1.0E+04
Br	4.2E+02	3.3E+02
Rb	2.0E+03	1.0E+03
Sr	3.0E+01	1.0E+02
Y	2.5E+01	1.0E+03
Zr	3.3E+00	6.7E+00
Nb	3.0E+04	1.0E+02
Mo	1.0E+01	1.0E+01
Tc	1.5E+01	5.0E+00
Ru	1.0E+01	3.0E+02
Rh	1.0E+01	3.0E+02
Te	4.0E+02	6.1E+03
I	1.5E+01	5.0E+00
Cs	2.0E+03	1.0E+03
Ba	4.0E+00	2.0E+02
La	2.5E+01	1.0E+03
Ce	1.0E+00	1.0E+03
Pr	2.5E+01	1.0E+03
Nd	2.5E+01	1.0E+03
W	1.2E+03	1.0E+01
Np	1.0E+01	4.0E+02

Table 4 - Highest Potential Exposure Pathways for Estimating Dose

Exposure Pathway	Location ^B	Direction ^B	Distance from Containment (miles) ^B	X/Q ^A { $\chi/Q(r,\theta)$ } (sec/m ³)	D/Q ^A { $\delta(r,\theta)$ } (m ⁻²)
Direct Exposure	Site Boundary	NW	0.29	4.90E-05	N/A
Inhalation	Site Boundary	NW	0.29	4.90E-05	N/A
Ingestion	Residence	SSE	0.60	N/A	7.6E-08

- A. These values are used for calculating quarterly dose estimates during the annual reporting period and are based on a 5 year historical average. At least ten percent (10%) should be added to these values for dose estimates during the reporting periods. These values are periodically re-evaluated by comparing the X/Q values reported by NOAA in similar locations.
- B. The location is subject to change based on an annual evaluation and is utilized only for ingestion exposure pathway dose estimates. This location may differ from the highest ingestion exposure pathway for offsite air monitoring locations as determined by the Land Use Survey performed biennially in accordance with Part 1, Section 7.3.2, of the Off-Site Dose Calculation Manual.

Table 5 - Stable Element Transfer Data

Element	B_{iv} Veg./Soil	F_m (cow) Milk (d/l)	F_m (goat) Milk (d/l)	F_f Meat (d/kg)
H	4.8E+00	1.0E-02	1.7E-01	1.2E-02
C	5.5E+00	1.2E-02	1.0E-01	3.1E-02
Na	5.2E-02	4.0E-02	-----	3.0E-02
P	1.1E+00	2.5E-02	2.5E-01	4.6E-02
Cr	2.5E-04	2.2E-03	-----	2.4E-03
Mn	2.9E-02	2.5E-04		8.0E-04
Fe	6.6E-04	1.2E-03	1.3E-04	4.0E-02
Co	9.4E-03	1.0E-03	-----	1.3E-02
Ni	1.9E-02	6.7E-03	-----	5.3E-02
Cu	1.2E-01	1.4E-02	1.3E-02	8.0E-03
Zn	4.0E-01	3.9E-02	-----	3.0E-02
Rb	1.3E-01	3.0E-02	-----	3.1E-02
Sr	1.7E-02	8.0E-04	1.4E-02	6.0E-04
Y	2.6E-03	1.0E-05	-----	4.6E-03
Zr	1.7E-04	5.0E-06	-----	3.4E-02
Nb	9.4E-03	2.5E-03	-----	2.8E-01
Mo	1.2E-01	7.5E-03	-----	8.0E-03
Tc	2.5E-01	2.5E-02	-----	4.0E-01
Ru	5.0E-02	1.0E-06	-----	4.0E-01
Rh	1.3E+1	1.0E-02	-----	1.5E-03
Ag	1.5E-01	5.0E-02	-----	1.7E-02
Sb	1.1E-02	1.5E-03	-----	4.0E-03
Te	1.3E+00	1.0E-03	-----	7.7E-02
I	2.0E-02	6.0E-03	6.0E-02	2.9E-03
Cs	1.0E-02	1.2E-02	3.0E-01	4.0E-03
Ba	5.0E-03	4.0E-04	-----	3.2E-03
La	2.5E-03	5.0E-06	-----	2.0E-04
Ce	2.5E-03	1.0E-04	-----	1.2E-03
Pr	2.5E-03	5.0E-06	-----	4.7E-03
Nd	2.4E-03	5.0E-06	-----	3.3E-03
W	1.8E-02	5.0E-04	-----	1.3E-03
Pu	2.5E-04	2.0E-06	-----	1.4E-05
Np	2.5E-03	5.0E-06	-----	2.0E-04
Am	2.5E-04	5.0E-06	-----	2.0E-04
Cm	2.5E-03	5.0E-06	-----	2.0E-04

Table 6 - Recommended Values for U_{ap} to Be Used for the Maximum Exposed Individual in Lieu of Site Specific Data

Pathway	Infant	Child	Teen	Adult
Fruits, vegetables, & grain (kg/yr)	---	520	630	520
Leafy vegetables (kg/yr)	---	26	42	64
Milk (P/yr)	330	330	400	310
Meat & poultry (kg/yr)	---	41	65	110
Fish (fresh or salt)(kg/yr)	---	6.9	16	21
Other Seafood (kg/yr)	---	1.7	3.8	5
Drinking water (P/yr)	330	510	510	730
Shoreline recreation (hr/yr)	---	14	67	12
Inhalation (m ³ /yr)	1400	3700	8000	8000

Table 7 - Animal Consumption Rates

Animal	Q_F Feed or Forage [Kg/day (wet weigh)]	Q_{AW} Water (ℓ/day)
Milk Cow	50	60
Beef Cattle	50	50
Goats	6	8

Table 8 - External Dose Factors for Standing on Contaminated Ground
(mrem/hr per pCi/m²)

Element	Total Body	Skin
H-3	---	---
C-14	---	---
Na-24	2.50E-08	2.90E-08
P-32	---	---
Cr-51	2.20E-10	2.60E-10
Mn-54	5.80E-09	6.80E-09
Mn-56	1.10E-08	1.30E-08
Fe-55	---	---
Fe-59	8.00E-09	9.40E-09
Co-58	7.00E-09	8.20E-09
Co-60	1.70E-08	2.00E-08
Ni-59	---	---
Ni-63	---	---
Nr-65	3.70E-09	4.30E-09
Cu-64	1.50E-09	1.70E-09
Zn-65	4.00E-09	4.60E-09
Zn-69	---	---
Br-83	6.40E-11	9.30E-11
Br-84	1.20E-08	1.40E-08
Br-85	---	---
Rb-86	6.30E-10	7.20E-10
Rb-88	3.50E-09	4.00E-09
Rb-89	1.50E-08	1.80E-08
Sr-89	5.60E-13	6.50E-13
Sr-91	7.10E-09	8.30E-09
Sr-92	9.00E-09	1.00E-08
Y-90	2.20E-12	2.60E-12
Y-91M	3.80E-09	4.40E-09
Y-91	2.40E-11	2.70E-11
Y-92	1.60E-09	1.90E-09
Y-93	5.70E-10	7.80E-10
Zr-95	5.00E-09	5.80E-09
Zr-97	5.50E-09	6.40E-09
Nb-95	5.10E-09	6.00E-09
Mo-99	1.90E-09	2.20E-09
Tc-99M	9.60E-10	1.10E-09
Tc-101	2.70E-09	3.00E-09

Table 8 - External Dose Factors for Standing on Contaminated Ground
(mrem/hr per pCi/m²)

Element	Total Body	Skin
Ru-103	3.60E-09	4.20E-09
Ru-105	4.50E-09	5.10E-09
Ru-106	1.50E-09	1.80E-09
Ag-110M	1.80E-08	2.10E-08
Sb-124	1.30E-08	1.50E-08
Sb-125	3.10E-09	3.50E-09
Te-125M	3.50E-11	4.80E-11
Te-127M	1.10E-12	1.30E-12
Te-127	1.00E-11	1.10E-11
Te-129M	7.70E-10	9.00E-10
Te-129	7.10E-10	8.40E-10
Te-131M	8.40E-09	9.90E-09
Te-131	2.20E-09	2.60E-06
Te-132	1.70E-09	2.00E-09
I-130	1.40E-08	1.70E-08
I-131	2.80E-09	3.40E-09
I-132	1.70E-08	2.00E-08
I-133	3.70E-09	4.50E-09
I-134	1.60E-08	1.90E-08
I-135	1.20E-08	1.40E-08
Cs-134	1.20E-08	1.40E-08
Cs-136	1.50E-08	1.70E-08
Cs-137	4.20E-09	4.90E-09
Cs-138	2.10E-08	2.40E-08
Ba-139	2.40E-09	2.70E-09
Ba-140	2.10E-09	2.40E-09
Ba-141	4.30E-09	4.90E-09
Ba-142	7.90E-09	9.00E-09
La-140	1.50E-08	1.70E-08
La-142	1.50E-08	1.80E-08
Ce-141	5.50E-10	6.20E-10
Ce-143	2.20E-09	2.50E-09
Ce-144	3.20E-10	3.70E-10
Pr-143	---	---
Pr-144	2.00E-10	2.30E-10
Nd-147	1.00E-09	1.20E-09
W-187	3.10E-09	3.60E-09

Table 8 - External Dose Factors for Standing on Contaminated Ground
(mrem/hr per pCi/m²)

Element	Total Body	Skin
Pu-238	1.30E-12	1.80E-11
Pu-239	7.90E-13	7.70E-12
Pu-240	1.30E-12	1.80E-11
Pu-241	4.60E-12	6.80E-12
Np-239	9.50E-10	1.10E-09
Am-241	1.80E-10	2.60E-10
Cm-242	5.50E-12	2.30E-11
Cm-243	2.30E-09	2.90E-09
Cm-244	2.90E-12	1.80E-11

Table 9 - Inhalation Dose Factors for Adult
(mrem per pCi Inhaled)

Nuclide	Bone	Liver	T. Body	Thyroid	Kidney	Lung	GI-LLI
H-3	---	8.98E-08	8.98E-08	8.98E-08	8.98E-08	8.98E-08	8.98E-08
C-14	2.27E-06	4.26E-07	4.26E-07	4.26E-07	4.26E-07	4.26E-07	4.26E-07
Na-24	1.28E-06	1.28E-06	1.28E-06	1.28E-06	1.28E-06	1.28E-06	1.28E-06
P-32	1.65E-04	9.64E-06	6.26E-06	---	---	---	1.08E-05
Cr-51	---	---	1.25E-08	7.44E-09	2.85E-09	1.80E-06	4.15E-07
Mn-54	---	4.95E-06	7.87E-07	---	1.23E-06	1.75E-04	9.67E-06
Mn-56	---	1.55E-10	2.29E-11	---	1.63E-10	1.18E-06	2.53E-06
Fe-55	3.07E-06	2.12E-06	4.93E-07	---	---	9.01E-06	7.54E-07
Fe-59	1.47E-06	3.47E-06	1.32E-06	---	---	1.27E-04	2.35E-05
Co-58	---	1.98E-07	2.59E-07	---	---	1.16E-04	1.33E-05
Co-60	---	1.44E-06	1.85E-06	---	---	7.46E-04	3.56E-05
Ni-59	4.06E-06	1.46E-06	6.77E-07	---	---	8.20E-06	6.11E-07
Ni-63	5.40E-05	3.93E-06	1.81E-06	---	---	2.23E-05	1.67E-06
Ni-65	1.92E-10	2.62E-11	1.14E-11	---	---	7.00E-07	1.54E-06
Cu-64	---	1.83E-10	7.69E-11	---	5.78E-10	8.48E-07	6.12E-06
Zn-65	4.05E-06	1.29E-05	5.82E-06	---	8.62E-06	1.08E-04	6.68E-06
Zn-69	4.23E-12	8.14E-12	5.65E-13	---	5.27E-12	1.15E-07	2.04E-09
Br-83	---	---	3.01E-08	---	---	---	2.90E-08
Br-84	---	---	3.91E-08	---	---	---	2.05E-13
Br-85	---	---	1.60E-09	---	---	---	---
Rb-86	---	1.69E-05	7.37E-06	---	---	---	2.08E-06
Rb-88	---	4.84E-08	2.41E-08	---	---	---	4.18E-19
Rb-89	---	3.20E-08	2.12E-08	---	---	---	1.16E-21
Sr-89	3.80E-05	---	1.09E-06	---	---	1.75E-04	4.37E-05
Sr-90	3.59E-03	---	7.21E-05	---	---	1.20E-03	9.02E-05
Sr-91	7.74E-09	---	3.13E-10	---	---	4.56E-06	2.39E-05
Sr-92	8.43E-10	---	3.64E-11	---	---	2.06E-06	5.38E-06
Y-90	2.61E-07	---	7.01E-09	---	---	2.12E-05	6.32E-05
Y-91M	3.26E-11	---	1.27E-12	---	---	2.40E-07	1.66E-10
Y-91	5.78E-05	---	1.55E-06	---	---	2.13E-04	4.81E-05
Y-92	1.29E-09	---	3.77E-11	---	---	1.96E-06	9.19E-06
Y-93	1.18E-08	---	3.26E-10	---	---	6.06E-06	5.27E-05
Zr-95	1.34E-05	4.30E-06	2.91E-06	---	6.77E-06	2.21E-04	1.88E-05
Zr-97	1.21E-08	2.45E-09	1.13E-09	---	3.71E-09	9.84E-06	6.54E-05
Nb-95	1.76E-06	9.77E-07	5.26E-07	---	9.67E-07	6.31E-05	1.30E-05
Mo-99	---	1.51E-08	2.87E-09	---	3.64E-08	1.14E-05	3.10E-05
Tc-99M	1.29E-13	3.64E-13	4.63E-12	---	5.52E-12	9.55E-08	5.20E-07

Table 9 - Inhalation Dose Factors for Adult
(mrem per pCi Inhaled)

Nuclide	Bone	Liver	T. Body	Thyroid	Kidney	Lung	GI-LLI
Tc-101	5.22E-15	7.52E-15	7.38E-14	---	1.35E-13	4.99E-08	1.36E-21
Ru-103	1.91E-07	---	8.23E-08	---	7.29E-07	6.31E-05	1.38E-05
Ru-105	9.88E-11	---	3.89E-11	---	1.27E-10	1.37E-06	6.02E-06
Ru-106	8.64E-06	---	1.09E-06	---	1.67E-05	1.17E-03	1.14E-04
Ag-110M	1.35E-06	1.25E-06	7.43E-07	---	2.46E-06	5.79E-04	3.78E-05
Sb-124	3.90E-06	7.36E-08	1.55E-06	9.44E-09	---	3.10E-04	5.08E-05
Sb-125	6.67E-06	7.44E-08	1.58E-06	6.75E-09	---	2.18E-04	1.26E-05
Te-125M	4.27E-07	1.98E-07	5.84E-08	1.31E-07	1.55E-06	3.92E-05	8.83E-06
Te-127M	1.58E-06	7.21E-07	1.96E-07	4.11E-07	5.72E-06	1.20E-04	1.87E-05
Te-127	1.75E-10	8.03E-11	3.87E-11	1.32E-10	6.37E-10	8.14E-07	7.17E-06
Te-129M	1.22E-06	5.84E-07	1.98E-07	4.30E-07	4.57E-06	1.45E-04	4.79E-05
Te-129	6.22E-12	2.99E-12	1.55E-12	4.87E-12	2.34E-11	2.42E-07	1.96E-08
Te-131M	8.74E-09	5.45E-09	3.63E-09	6.88E-09	3.86E-08	1.82E-05	6.95E-05
Te-131	1.39E-12	7.44E-13	4.49E-13	1.17E-12	5.46E-12	1.74E-07	2.30E-09
Te-132	3.25E-08	2.69E-08	2.02E-08	2.37E-08	1.82E-07	3.60E-05	6.37E-05
I-130	5.72E-07	1.68E-06	6.60E-07	1.42E-04	2.61E-06	---	9.61E-07
I-131	3.15E-06	4.47E-06	2.56E-06	1.49E-03	7.66E-06	---	7.85E-07
I-132	1.45E-07	4.07E-07	1.45E-07	1.43E-05	6.48E-07	---	5.08E-08
I-133	1.08E-06	1.85E-06	5.65E-07	2.69E-04	3.23E-06	---	1.11E-06
I-134	8.05E-08	2.16E-07	7.69E-08	3.73E-06	3.44E-07	---	1.26E-10
I-135	3.35E-07	8.73E-07	3.21E-07	5.60E-05	1.39E-06	---	6.56E-07
Cs-134	4.66E-05	1.06E-04	9.10E-05	---	3.59E-05	1.22E-05	1.30E-06
Cs-136	4.88E-06	1.83E-05	1.38E-05	---	1.07E-05	1.50E-06	1.46E-06
Cs-137	5.98E-05	7.76E-05	5.35E-05	---	2.78E-05	9.40E-06	1.05E-06
Cs-138	4.14E-08	7.76E-08	4.05E-08	---	6.00E-08	6.07E-09	2.33E-13
Ba-139	1.17E-10	8.32E-14	3.42E-12	---	7.78E-14	4.70E-07	1.12E-07
Ba-140	4.88E-06	6.13E-09	3.21E-07	---	2.09E-09	1.59E-04	2.73E-05
Ba-141	1.25E-11	9.41E-15	4.20E-13	---	8.75E-15	2.42E-07	1.45E-17
Ba-142	3.29E-12	3.38E-15	2.07E-13	---	2.86E-15	1.49E-07	1.96E-26
La-140	4.30E-08	2.17E-08	5.73E-09	---	---	1.70E-05	5.73E-05
La-142	8.54E-11	3.88E-11	9.65E-12	---	---	7.91E-07	2.64E-07
Ce-141	2.49E-06	1.69E-06	1.91E-07	---	7.83E-07	4.52E-05	1.50E-05
Ce-143	2.33E-08	1.72E-08	1.91E-09	---	7.60E-09	9.97E-06	2.83E-05
Ce-144	4.29E-04	1.79E-04	2.30E-05	---	1.06E-04	9.72E-04	1.02E-04
Pr-143	1.17E-06	4.69E-07	5.80E-08	---	2.70E-07	3.51E-05	2.50E-05
Pr-144	3.76E-12	1.56E-12	1.91E-13	---	8.81E-13	1.27E-07	2.69E-18
Nd-147	6.59E-07	7.62E-07	4.56E-08	---	4.45E-07	2.76E-05	2.16E-05

Table 9 - Inhalation Dose Factors for Adult
(mrem per pCi Inhaled)

Nuclide	Bone	Liver	T. Body	Thyroid	Kidney	Lung	GI-LLI
W-187	1.06E-09	8.85E-10	3.10E-10	---	---	3.63E-06	1.94E-05
Pu-238	1.43E+00	9.71E-01	6.90E-02	---	2.96E-01	1.82E-01	4.52E-05
Pu-239	1.66E+00	1.07E+00	7.75E-02	---	3.30E-01	1.72E-01	4.13E-05
Pu-240	1.65E+00	1.07E+00	7.73E-02	---	3.29E-01	1.72E-01	4.21E-05
Pu-241	3.42E-02	8.69E-03	1.29E-03	---	5.93E-03	1.52E-04	8.65E-07
Np-239	2.87E-08	2.54E-08	1.55E-09	---	8.75E-09	4.70E-06	1.49E-05
Am-241	1.68E+00	1.13E+00	6.71E-02	---	5.04E-01	6.06E-02	4.60E-05
Cm-242	2.22E-02	1.77E-02	9.84E-04	---	4.48E-03	3.92E-02	4.91E-05
Cm-243	1.10E+00	7.61E-01	4.61E-02	---	2.15E-01	6.31E-02	4.84E-05
Cm-244	8.37E-01	5.88E-01	3.51E-02	---	1.64E-01	6.06E-02	4.68E-05

Table 10 - Inhalation Dose Factors for Teenager
(mrem per pCi Inhaled)

Nuclide	Bone	Liver	T. Body	Thyroid	Kidney	Lung	GI-LLI
H-3	---	9.06E-08	9.06E-08	9.06E-08	9.06E-08	9.06E-08	9.06E-08
C-14	3.25E-06	6.09E-07	6.09E-07	6.09E-07	6.09E-07	6.09E-07	6.09E-07
Na-24	1.72E-06	1.72E-06	1.72E-06	1.72E-06	1.72E-06	1.72E-06	1.72E-06
P-32	2.36E-04	1.37E-05	8.95E-06	---	---	---	1.16E-05
Cr-51	---	---	1.69E-08	9.37E-09	3.84E-09	2.62E-06	3.75E-07
Mn-54	---	6.39E-06	1.05E-06	---	1.59E-06	2.48E-04	8.35E-06
Mn-56	---	2.12E-10	3.15E-11	---	2.24E-10	1.90E-06	7.18E-06
Fe-55	4.18E-06	2.98E-06	6.93E-07	---	---	1.55E-05	7.99E-07
Fe-59	1.99E-06	4.62E-06	1.79E-06	---	---	1.91E-04	2.23E-05
Co-58	---	2.59E-07	3.47E-07	---	---	1.68E-04	1.19E-05
Co-60	---	1.89E-06	2.48E-06	---	---	1.09E-03	3.24E-05
Ni-59	5.44E-06	2.02E-06	9.24E-07	---	---	1.41E-05	6.48E-07
Ni-63	7.25E-05	5.43E-06	2.47E-06	---	---	3.84E-05	1.77E-06
Ni-65	2.73E-10	3.66E-11	1.59E-11	---	---	1.17E-06	4.59E-06
Cu-64	---	2.54E-10	1.06E-10	---	8.01E-10	1.39E-06	7.68E-06
Zn-65	4.82E-06	1.67E-05	7.80E-06	---	1.08E-05	1.55E-04	5.83E-06
Zn-69	6.04E-12	1.15E-11	8.07E-13	---	7.53E-12	1.98E-07	3.56E-08
Br-83	---	---	4.30E-08	---	---	---	---
Br-84	---	---	5.41E-08	---	---	---	---
Br-85	---	---	2.29E-09	---	---	---	---
Rb-86	---	2.38E-05	1.05E-05	---	---	---	2.21E-06
Rb-88	---	6.82E-08	3.40E-08	---	---	---	3.65E-15
Rb-89	---	4.40E-08	2.91E-08	---	---	---	4.22E-17
Sr-89	5.43E-05	---	1.56E-06	---	---	3.02E-04	4.64E-05
Sr-90	4.14E-03	---	8.33E-05	---	---	2.06E-03	9.56E-05
Sr-91	1.10E-08	---	4.39E-10	---	---	7.59E-06	3.24E-05
Sr-92	1.19E-09	---	5.08E-11	---	---	3.43E-06	1.49E-05
Y-90	3.73E-07	---	1.00E-08	---	---	3.66E-05	6.99E-05
Y-91M	4.63E-11	---	1.77E-12	---	---	4.00E-07	3.77E-09
Y-91	8.26E-05	---	2.21E-06	---	---	3.67E-04	5.11E-05
Y-92	1.84E-09	---	5.36E-11	---	---	3.35E-06	2.06E-05
Y-93	1.69E-08	---	4.65E-10	---	---	1.04E-05	7.24E-05
Zr-95	1.82E-05	5.73E-06	3.94E-06	---	8.42E-06	3.36E-04	1.86E-05
Zr-97	1.72E-08	3.40E-09	1.57E-09	---	5.15E-09	1.62E-05	7.88E-05
Nb-95	2.32E-06	1.29E-06	7.08E-07	---	1.25E-06	9.39E-05	1.21E-05
Mo-99	---	2.11E-08	4.03E-09	---	5.14E-08	1.92E-05	3.36E-05
Tc-99M	1.73E-13	4.83E-13	6.24E-12	---	7.20E-12	1.44E-07	7.66E-07

Table 10 - Inhalation Dose Factors for Teenager
(mrem per pCi Inhaled)

Nuclide	Bone	Liver	T. Body	Thyroid	Kidney	Lung	GI-LLI
Tc-101	7.40E-15	1.05E-14	1.03E-13	---	1.90E-13	8.34E-08	1.09E-16
Ru-103	2.63E-07	---	1.12E-07	---	9.29E-07	9.79E-05	1.36E-05
Ru-105	1.40E-10	---	5.42E-11	---	1.76E-10	2.27E-06	1.13E-05
Ru-106	1.23E-05	---	1.55E-06	---	2.38E-05	2.01E-03	1.20E-04
Ag-110M	1.73E-06	1.64E-06	9.99E-07	---	3.13E-06	8.44E-04	3.41E-05
Sb-124	5.38E-06	9.92E-08	2.10E-06	1.22E-08	---	4.81E-04	4.98E-05
Sb-125	9.23E-06	1.01E-07	2.15E-06	8.80E-09	---	3.42E-04	1.24E-05
Te-125M	6.10E-07	2.80E-07	8.34E-08	1.75E-07	---	6.70E-05	9.38E-06
Te-127M	2.25E-06	1.02E-06	2.73E-07	5.48E-07	8.17E-06	2.07E-04	1.99E-05
Te-127	2.51E-10	1.14E-10	5.52E-11	1.77E-10	9.10E-10	1.40E-06	1.01E-05
Te-129M	1.74E-06	8.23E-07	2.81E-07	5.72E-07	6.49E-06	2.47E-04	5.06E-05
Te-129	8.87E-12	4.22E-12	2.20E-12	6.48E-12	3.32E-11	4.12E-07	2.02E-07
Te-131M	1.23E-08	7.51E-09	5.03E-09	9.06E-09	5.49E-08	2.97E-05	7.76E-05
Te-131	1.97E-12	1.04E-12	6.30E-13	1.55E-12	7.72E-12	2.92E-07	1.89E-09
Te-132	4.50E-08	3.63E-08	2.74E-08	3.07E-08	2.44E-07	5.61E-05	5.79E-05
I-130	7.80E-07	2.24E-06	8.96E-07	1.86E-04	3.44E-06	---	1.14E-06
I-131	4.43E-06	6.14E-06	3.30E-06	1.83E-03	1.05E-05	---	8.11E-07
I-132	1.99E-07	5.47E-07	1.97E-07	1.89E-05	8.65E-07	---	1.59E-07
I-133	1.52E-06	2.56E-06	7.78E-07	3.65E-04	4.49E-06	---	1.29E-06
I-134	1.11E-07	2.90E-07	1.05E-07	4.94E-06	4.58E-07	---	2.55E-09
I-135	4.62E-07	1.18E-06	4.36E-07	7.76E-05	1.86E-06	---	8.69E-07
Cs-134	6.28E-05	1.41E-04	6.86E-05	---	4.69E-05	1.83E-05	1.22E-06
Cs-136	6.44E-06	2.42E-05	1.71E-05	---	1.38E-05	2.22E-06	1.36E-06
Cs-137	8.38E-05	1.06E-04	3.89E-05	---	3.80E-05	1.51E-05	1.06E-06
Cs-138	5.82E-08	1.07E-07	5.58E-08	---	8.28E-08	9.84E-09	3.38E-11
Ba-139	1.67E-10	1.18E-13	4.87E-12	---	1.11E-13	8.08E-07	8.06E-07
Ba-140	6.84E-06	8.38E-09	4.40E-07	---	2.85E-09	2.54E-04	2.86E-05
Ba-141	1.78E-11	1.32E-14	5.93E-13	---	1.23E-14	4.11E-07	9.33E-14
Ba-142	4.62E-12	4.63E-15	2.84E-13	---	3.92E-15	2.39E-07	5.99E-20
La-140	5.99E-08	2.95E-08	7.82E-09	---	---	2.68E-05	6.09E-05
La-142	1.20E-10	5.31E-11	1.32E-11	---	---	1.27E-06	1.50E-06
Ce-141	3.55E-06	2.37E-06	2.71E-07	---	1.11E-06	7.67E-05	1.58E-05
Ce-143	3.32E-08	2.42E-08	2.70E-09	---	1.08E-08	1.63E-05	3.19E-05
Ce-144	6.11E-04	2.53E-04	3.28E-05	---	1.51E-04	1.67E-03	1.08E-04
Pr-143	1.67E-06	6.64E-07	8.28E-08	---	3.86E-07	6.04E-05	2.67E-05
Pr-144	5.37E-12	2.20E-12	2.72E-13	---	1.26E-12	2.19E-07	2.94E-14
Nd-147	9.83E-07	1.07E-06	6.41E-08	---	6.28E-07	4.65E-05	2.28E-05

Table 10 - Inhalation Dose Factors for Teenager
(mrem per pCi Inhaled)

Nuclide	Bone	Liver	T. Body	Thyroid	Kidney	Lung	GI-LLI
W-187	1.50E-09	1.22E-09	4.29E-10	---	---	5.92E-06	2.21E-05
Pu-238	1.50E+00	1.03E+00	7.22E-02	---	3.10E-01	3.12E-01	4.79E-05
Pu-239	1.73E+00	1.12E+00	8.05E-02	---	3.44E-01	2.93E-01	4.37E-05
Pu-240	1.72E+00	1.12E+00	8.04E-02	---	3.43E-01	2.93E-01	4.46E-05
Pu-241	3.74E-02	9.56E-03	1.40E-03	---	6.47E-03	2.60E-04	9.17E-07
Np-239	4.23E-08	3.60E-08	2.21E-09	---	1.25E-08	8.11E-06	1.65E-05
Am-241	1.77E+00	1.20E+00	7.10E-02	---	5.32E-01	1.05E-01	4.88E-05
Cm-242	3.17E-02	2.51E-02	1.41E-03	---	6.40E-03	6.76E-02	5.21E-05
Cm-243	1.19E+00	8.30E-01	5.00E-02	---	2.34E-01	1.09E-01	5.13E-05
Cm-244	9.19E-01	6.53E-01	3.88E-02	---	1.81E-01	1.05E-01	4.96E-05

Table 11 - Inhalation Dose Factors for Child
(mrem per pCi Inhaled)

Nuclide	Bone	Liver	T. Body	Thyroid	Kidney	Lung	GI-LLI
H-3	---	1.73E-07	1.73E-07	1.73E-07	1.73E-07	1.73E-07	1.73E-07
C-14	9.70E-06	1.82E-06	1.82E-06	1.82E-06	1.82E-06	1.82E-06	1.82E-06
Na-24	4.35E-06	4.35E-06	4.35E-06	4.35E-06	4.35E-06	4.35E-06	4.35E-06
P-32	7.04E-04	3.09E-05	2.67E-05	---	---	---	1.14E-05
Cr-51	---	---	4.17E-08	2.31E-08	6.57E-09	4.59E-06	2.93E-07
Mn-54	---	1.16E-05	2.57E-06	---	2.71E-06	4.26E-04	6.19E-06
Mn-56	---	4.48E-10	8.43E-11	---	4.52E-10	3.55E-06	3.33E-05
Fe-55	1.28E-05	6.80E-06	2.10E-06	---	---	3.00E-05	7.75E-07
Fe-59	5.59E-06	9.04E-06	4.51E-06	---	---	3.43E-04	1.91E-05
Co-58	---	4.79E-07	8.55E-07	---	---	2.99E-04	9.29E-06
Co-60	---	3.55E-06	6.12E-06	---	---	1.91E-03	2.60E-05
Ni-59	1.66E-05	4.67E-06	2.83E-06	---	---	2.73E-05	6.29E-07
Ni-63	2.22E-04	1.25E-05	7.56E-06	---	---	7.43E-05	1.71E-06
Ni-65	8.08E-10	7.99E-11	4.44E-11	---	---	2.21E-06	2.27E-05
Cu-64	---	5.39E-10	2.90E-10	---	1.63E-09	2.59E-06	9.92E-06
Zn-65	1.15E-05	3.06E-05	1.90E-05	---	1.93E-05	2.69E-04	4.41E-06
Zn-69	1.81E-11	2.61E-11	2.41E-12	---	1.58E-11	3.84E-07	2.75E-06
Br-83	---	---	1.28E-07	---	---	---	---
Br-84	---	---	1.48E-07	---	---	---	---
Br-85	---	---	6.84E-09	---	---	---	---
Rb-86	---	5.36E-05	3.09E-05	---	---	---	2.16E-06
Rb-88	---	1.52E-07	9.90E-08	---	---	---	4.66E-09
Rb-89	---	9.33E-08	7.85E-08	---	---	---	5.11E-10
Sr-89	1.62E-04	---	4.66E-06	---	---	5.83E-04	4.52E-05
Sr-90	1.04E-02	---	2.07E-04	---	---	3.99E-03	9.28E-05
Sr-91	3.28E-08	---	1.24E-09	---	---	1.44E-05	4.70E-05
Sr-92	3.54E-09	---	1.42E-10	---	---	6.49E-06	6.55E-05
Y-90	1.11E-06	---	2.99E-08	---	---	7.07E-05	7.24E-05
Y-91M	1.37E-10	---	4.98E-12	---	---	7.60E-07	4.64E-07
Y-91	2.47E-04	---	6.59E-06	---	---	7.10E-04	4.97E-05
Y-92	5.50E-09	---	1.57E-10	---	---	6.46E-06	6.46E-05
Y-93	5.04E-08	---	1.38E-09	---	---	2.01E-05	1.05E-04
Zr-95	5.13E-05	1.13E-05	1.00E-05	---	1.61E-05	6.03E-04	1.65E-05
Zr-97	5.07E-08	7.34E-09	4.32E-09	---	1.05E-08	3.06E-05	9.49E-05
Nb-95	6.35E-06	2.48E-06	1.77E-06	---	2.33E-06	1.66E-04	1.00E-05
Mo-99	---	4.66E-08	1.15E-08	---	1.06E-07	3.66E-05	3.42E-05
Tc-99M	4.81E-13	9.41E-13	1.56E-11	---	1.37E-11	2.57E-07	1.30E-06

Table 11 - Inhalation Dose Factors for Child
(mrem per pCi Inhaled)

Nuclide	Bone	Liver	T. Body	Thyroid	Kidney	Lung	GI-LLI
Tc-101	2.19E-14	2.30E-14	2.91E-13	---	3.92E-13	1.58E-07	4.41E-09
Ru-103	7.55E-07	---	2.90E-07	---	1.90E-06	1.79E-04	1.21E-05
Ru-105	4.13E-10	---	1.50E-10	---	3.63E-10	4.30E-06	2.69E-05
Ru-106	3.68E-05	---	4.57E-06	---	4.97E-05	3.87E-03	1.16E-04
Ag-110M	4.56E-06	3.08E-06	2.47E-06	---	5.74E-06	1.48E-03	2.71E-05
Sb-124	1.55E-05	2.00E-07	5.41E-06	3.41E-08	---	8.76E-04	4.43E-05
Sb-125	2.66E-05	2.05E-07	5.59E-06	2.46E-08	---	6.27E-04	1.09E-05
Te-125M	1.82E-06	6.29E-07	2.47E-07	5.20E-07	---	1.29E-04	9.13E-06
Te-127M	6.72E-06	2.31E-06	8.16E-07	1.64E-06	1.72E-05	4.00E-04	1.93E-05
Te-127	7.49E-10	2.57E-10	1.65E-10	5.30E-10	1.91E-09	2.71E-06	1.52E-05
Te-129M	5.19E-06	1.85E-06	8.22E-07	1.71E-06	1.36E-05	4.76E-04	4.91E-05
Te-129	2.64E-11	9.45E-12	6.44E-12	1.93E-11	6.94E-11	7.93E-07	6.89E-06
Te-131M	3.63E-08	1.60E-08	1.37E-08	2.64E-08	1.08E-07	5.56E-05	8.32E-05
Te-131	5.87E-12	2.28E-12	1.78E-12	4.59E-12	1.59E-11	5.55E-07	3.60E-07
Te-132	1.30E-07	7.36E-08	7.12E-08	8.58E-08	4.79E-07	1.02E-04	3.72E-05
I-130	2.21E-06	4.43E-06	2.28E-06	4.99E-04	6.61E-06	---	1.38E-06
I-131	1.30E-05	1.30E-05	7.37E-06	4.39E-03	2.13E-05	---	7.68E-07
I-132	5.72E-07	1.10E-06	5.07E-07	5.23E-05	1.69E-06	---	8.65E-07
I-133	4.48E-06	5.49E-06	2.08E-06	1.04E-03	9.13E-06	---	1.48E-06
I-134	3.17E-07	5.84E-07	2.69E-07	1.37E-05	8.92E-07	---	2.58E-07
I-135	1.33E-06	2.36E-06	1.12E-06	2.14E-04	3.62E-06	---	1.20E-06
Cs-134	1.76E-04	2.74E-04	6.07E-05	---	8.93E-05	3.27E-05	1.04E-06
Cs-136	1.76E-05	4.62E-05	3.14E-05	---	2.58E-05	3.93E-06	1.13E-06
Cs-137	2.45E-04	2.23E-04	3.47E-05	---	7.63E-05	2.81E-05	9.78E-07
Cs-138	1.71E-07	2.27E-07	1.50E-07	---	1.68E-07	1.84E-08	7.29E-08
Ba-139	4.98E-10	2.66E-13	1.45E-11	---	2.33E-13	1.56E-06	1.56E-05
Ba-140	2.00E-05	1.75E-08	1.17E-06	---	5.71E-09	4.71E-04	2.75E-05
Ba-141	5.29E-11	2.95E-14	1.72E-12	---	2.56E-14	7.89E-07	7.44E-08
Ba-142	1.35E-11	9.73E-15	7.54E-13	---	7.87E-15	4.44E-07	7.41E-10
La-140	1.74E-07	6.08E-08	2.04E-08	---	---	4.94E-05	6.10E-05
La-142	3.50E-10	1.11E-10	3.49E-11	---	---	2.35E-06	2.05E-05
Ce-141	1.06E-05	5.28E-06	7.83E-07	---	2.31E-06	1.47E-04	1.53E-05
Ce-143	9.89E-08	5.37E-08	7.77E-09	---	2.26E-08	3.12E-05	3.44E-05
Ce-144	1.83E-03	5.72E-04	9.77E-05	---	3.17E-04	3.23E-03	1.05E-04
Pr-143	4.99E-06	1.50E-06	2.47E-07	---	8.11E-07	1.17E-04	2.63E-05
Pr-144	1.61E-11	4.99E-12	8.10E-13	---	2.64E-12	4.23E-07	5.32E-08
Nd-147	2.92E-06	2.36E-06	1.84E-07	---	1.30E-06	8.87E-05	2.22E-05

Table 11 - Inhalation Dose Factors for Child
(mrem per pCi Inhaled)

Nuclide	Bone	Liver	T. Body	Thyroid	Kidney	Lung	GI-LLI
W-187	4.41E-09	2.61E-09	1.17E-09	---	---	1.11E-05	2.46E-05
Pu-238	2.55E+00	1.60E+00	1.21E-01	---	4.47E-01	6.08E-01	4.65E-05
Pu-239	2.79E+00	1.68E+00	1.28E-01	---	4.78E-01	5.72E-01	4.24E-05
Pu-240	2.79E+00	1.68E+00	1.27E-01	---	4.77E-01	5.71E-01	4.33E-05
Pu-241	7.94E-02	1.75E-02	2.93E-03	---	1.10E-02	5.06E-04	8.90E-07
Np-239	1.26E-07	8.14E-08	6.35E-09	---	2.63E-08	1.57E-05	1.73E-05
Am-241	2.97E+00	1.84E+00	1.24E-01	---	7.63E-01	2.02E-01	4.73E-05
Cm-242	9.48E-02	5.68E-02	4.20E-03	---	1.34E-02	1.31E-01	5.06E-05
Cm-243	2.32E+00	1.42E+00	9.95E-02	---	3.74E-01	2.10E-01	4.98E-05
Cm-244	1.94E+00	1.18E+00	8.31E-02	---	3.06E-01	2.02E-01	4.82E-05

Table 12 - Inhalation Dose Factors for Infant
(mrem per pCi Inhaled)

Nuclide	Bone	Liver	T. Body	Thyroid	Kidney	Lung	GI-LLI
H-3	---	2.63E-07	2.63E-07	2.63E-07	2.63E-07	2.63E-07	2.63E-07
C-14	1.89E-05	3.79E-06	3.79E-06	3.79E-06	3.79E-06	3.79E-06	3.79E-06
Na-24	7.54E-06	7.54E-06	7.54E-06	7.54E-06	7.54E-06	7.54E-06	7.54E-06
P-32	1.45E-03	8.03E-05	5.53E-05	---	---	---	1.15E-05
Cr-51	---	---	6.39E-08	4.11E-08	9.45E-09	9.17E-06	2.55E-07
Mn-54	---	1.81E-05	3.56E-06	---	3.56E-06	7.14E-04	5.04E-06
Mn-56	---	1.10E-09	1.58E-10	---	7.86E-10	8.95E-06	5.12E-05
Fe-55	1.41E-05	8.39E-06	2.38E-06	---	---	6.21E-05	7.82E-07
Fe-59	9.69E-06	1.68E-05	6.77E-06	---	---	7.25E-04	1.77E-05
Co-58	---	8.71E-07	1.30E-06	---	---	5.55E-04	7.95E-06
Co-60	---	5.73E-06	8.41E-06	---	---	3.22E-03	2.28E-05
Ni-59	1.81E-05	5.44E-06	3.10E-06	---	---	5.48E-05	6.34E-07
Ni-63	2.42E-04	1.46E-05	8.29E-06	---	---	1.49E-04	1.73E-06
Ni-65	1.71E-09	2.03E-10	8.79E-11	---	---	5.80E-06	3.58E-05
Cu-64	---	1.34E-09	5.53E-10	---	2.84E-09	6.64E-06	1.07E-05
Zn-65	1.38E-05	4.47E-05	2.22E-05	---	2.32E-05	4.62E-04	3.67E-05
Zn-69	3.85E-11	6.91E-11	5.13E-12	---	2.87E-11	1.05E-06	9.44E-06
Br-83	---	---	2.72E-07	---	---	---	---
Br-84	---	---	2.86E-07	---	---	---	---
Br-85	---	---	1.46E-08	---	---	---	---
Rb-86	---	1.36E-04	6.30E-05	---	---	---	2.17E-06
Rb-88	---	3.98E-07	2.05E-07	---	---	---	2.42E-07
Rb-89	---	2.29E-07	1.47E-07	---	---	---	4.87E-08
Sr-89	2.84E-04	---	8.15E-06	---	---	1.45E-03	4.57E-05
Sr-90	1.11E-02	---	2.23E-04	---	---	8.03E-03	9.36E-05
Sr-91	6.83E-08	---	2.47E-09	---	---	3.76E-05	5.24E-05
Sr-92	7.50E-09	---	2.79E-10	---	---	1.70E-05	1.00E-04
Y-90	2.35E-06	---	6.30E-08	---	---	1.92E-04	7.43E-05
Y-91M	2.91E-10	---	9.90E-12	---	---	1.99E-06	1.68E-06
Y-91	4.20E-04	---	1.12E-05	---	---	1.75E-03	5.02E-05
Y-92	1.17E-08	---	3.29E-10	---	---	1.75E-05	9.04E-05
Y-93	1.07E-07	---	2.91E-09	---	---	5.46E-05	1.19E-04
Zr-95	8.24E-05	1.99E-05	1.45E-05	---	2.22E-05	1.25E-03	1.55E-05
Zr-97	1.07E-07	1.83E-08	8.36E-09	---	1.85E-08	7.88E-05	1.00E-04
Nb-95	1.12E-05	4.59E-06	2.70E-06	---	3.37E-06	3.42E-04	9.05E-06
Mo-99	---	1.18E-07	2.31E-08	---	1.89E-07	9.63E-05	3.48E-05
Tc-99M	9.98E-13	2.06E-12	2.66E-11	---	2.22E-11	5.79E-07	1.45E-06

Table 12 - Inhalation Dose Factors for Infant
(mrem per pCi Inhaled)

Nuclide	Bone	Liver	T. Body	Thyroid	Kidney	Lung	GI-LLI
Tc-101	4.65E-14	5.88E-14	5.80E-13	---	6.99E-13	4.17E-07	6.03E-07
Ru-103	1.44E-06	---	4.85E-07	---	3.03E-06	3.94E-04	1.15E-05
Ru-105	8.74E-10	---	2.93E-10	---	6.42E-10	1.12E-05	3.46E-05
Ru-106	6.20E-05	---	7.77E-06	---	7.61E-05	8.26E-03	1.17E-04
Ag-110M	7.13E-06	5.16E-06	3.57E-06	---	7.80E-06	2.62E-03	2.36E-05
Sb-124	2.71E-05	3.97E-07	8.56E-06	7.18E-08	---	1.89E-03	4.22E-05
Sb-125	3.69E-05	3.41E-07	7.78E-06	4.45E-08	---	1.17E-03	1.05E-05
Te-125M	3.40E-06	1.42E-06	4.70E-07	1.16E-06	---	3.19E-04	9.22E-06
Te-127M	1.19E-05	4.93E-06	1.48E-06	3.48E-06	2.68E-05	9.37E-04	1.95E-05
Te-127	1.59E-09	6.81E-10	3.40E-10	1.32E-09	3.47E-09	7.39E-06	1.74E-05
Te-129M	1.01E-05	4.35E-06	1.59E-06	3.91E-06	2.27E-05	1.20E-03	4.93E-05
Te-129	5.63E-11	2.48E-11	1.34E-11	4.82E-11	1.25E-10	2.14E-06	1.88E-05
Te-131M	7.62E-08	3.93E-08	2.59E-08	6.38E-08	1.89E-07	1.42E-04	8.51E-05
Te-131	1.24E-11	5.87E-12	3.57E-12	1.13E-11	2.85E-11	1.47E-06	5.87E-06
Te-132	2.66E-07	1.69E-07	1.26E-07	1.99E-07	7.39E-07	2.43E-04	3.15E-05
I-130	4.54E-06	9.91E-06	3.98E-06	1.14E-03	1.09E-05	---	1.42E-06
I-131	2.71E-05	3.17E-05	1.40E-05	1.06E-02	3.70E-05	---	7.56E-07
I-132	1.21E-06	2.53E-06	8.99E-07	1.21E-04	2.82E-06	---	1.36E-06
I-133	9.46E-06	1.37E-05	4.00E-06	2.54E-03	1.60E-05	---	1.54E-06
I-134	6.58E-07	1.34E-06	4.75E-07	3.18E-05	1.49E-06	---	9.21E-07
I-135	2.76E-06	5.43E-06	1.98E-06	4.97E-04	6.05E-06	---	1.31E-06
Cs-134	2.83E-04	5.02E-04	5.32E-05	---	1.36E-04	5.69E-05	9.53E-07
Cs-136	3.45E-05	9.61E-05	3.78E-05	---	4.03E-05	8.40E-06	1.02E-06
Cs-137	3.92E-04	4.37E-04	3.25E-05	---	1.23E-04	5.09E-05	9.53E-07
Cs-138	3.61E-07	5.58E-07	2.84E-07	---	2.93E-07	4.67E-08	6.26E-07
Ba-139	1.06E-09	7.03E-13	3.07E-11	---	4.23E-13	4.25E-06	3.64E-05
Ba-140	4.00E-05	4.00E-08	2.07E-06	---	9.59E-09	1.14E-03	2.74E-05
Ba-141	1.12E-10	7.70E-14	3.55E-12	---	4.64E-14	2.12E-06	3.39E-06
Ba-142	2.84E-11	2.36E-14	1.40E-12	---	1.36E-14	1.11E-06	4.95E-07
La-140	3.61E-07	1.43E-07	3.68E-08	---	---	1.20E-04	6.06E-05
La-142	7.36E-10	2.69E-10	6.46E-11	---	---	5.87E-06	4.25E-05
Ce-141	1.98E-05	1.19E-05	1.42E-06	---	3.75E-06	3.69E-04	1.54E-05
Ce-143	2.09E-07	1.38E-07	1.58E-08	---	4.03E-08	8.30E-05	3.55E-05
Ce-144	2.28E-03	8.65E-04	1.26E-04	---	3.84E-04	7.03E-03	1.06E-04
Pr-143	1.00E-05	3.74E-06	4.99E-07	---	1.41E-06	3.09E-04	2.66E-05
Pr-144	3.42E-11	1.32E-11	1.72E-12	---	4.80E-12	1.15E-06	3.06E-06
Nd-147	5.67E-06	5.81E-06	3.57E-07	---	2.25E-06	2.30E-04	2.23E-05

Table 12 - Inhalation Dose Factors for Infant
(mrem per pCi Inhaled)

Nuclide	Bone	Liver	T. Body	Thyroid	Kidney	Lung	GI-LLI
W-187	9.26E-09	6.44E-09	2.23E-09	---	---	2.83E-05	2.54E-05
Pu-238	2.69E+00	1.68E+00	1.27E-01	---	4.64E-01	9.03E-01	4.69E-05
Pu-239	2.93E+00	1.76E+00	1.34E-01	---	4.95E-01	8.47E-01	4.28E-05
Pu-240	2.93E+00	1.75E+00	1.34E-01	---	4.94E-01	8.47E-01	4.36E-05
Pu-241	8.43E-02	1.85E-02	3.11E-03	---	1.15E-02	7.62E-04	8.97E-07
Np-239	2.65E-07	2.13E-07	1.34E-08	---	4.73E-08	4.25E-05	1.78E-05
Am-241	3.15E+00	1.95E+00	1.31E-01	---	7.94E-01	4.06E-01	4.78E-05
Cm-242	1.28E-01	8.65E-02	5.70E-03	---	1.69E-02	2.97E-01	5.10E-05
Cm-243	2.47E+00	1.52E+00	1.06E-01	---	3.91E-01	4.24E-01	5.02E-05
CM-244	2.07E+00	1.27E+00	8.89E-02	---	3.21E-01	4.08E-01	4.86E-05

Table 13 - Ingestion Dose Factors for Adult
(mrem per pCi Ingested)

Nuclide	Bone	Liver	T. Body	Thyroid	Kidney	Lung	GI-LLI
H-3	---	5.99E-08	5.99E-08	5.99E-08	5.99E-08	5.99E-08	5.99E-08
C-14	2.84E-06	5.68E-07	5.68E-07	5.68E-07	5.68E-07	5.68E-07	5.68E-07
Na-24	1.70E-06	1.70E-06	1.70E-06	1.70E-06	1.70E-06	1.70E-06	1.70E-06
P-32	1.93E-04	1.20E-05	7.46E-06	---	---	---	2.17E-05
Cr-51	---	---	2.66E-09	1.59E-09	5.86E-10	3.53E-09	6.69E-07
Mn-54	---	4.57E-06	8.72E-07	---	1.36E-06	---	1.40E-05
Mn-56	---	1.15E-07	2.04E-08	---	1.46E-07	---	3.67E-06
Fe-55	2.75E-06	1.90E-06	4.43E-07	---	---	1.06E-06	1.09E-06
Fe-59	4.34E-06	1.02E-05	3.91E-06	---	---	2.85E-06	3.40E-05
Co-58	---	7.45E-07	1.67E-06	---	---	---	1.51E-05
Co-60	---	2.14E-06	4.72E-06	---	---	---	4.02E-05
Ni-59	9.76E-06	3.35E-06	1.63E-06	---	---	---	6.90E-07
Ni-63	1.30E-04	9.01E-06	4.36E-06	---	---	---	1.88E-06
Ni-65	5.28E-07	6.86E-08	3.13E-08	---	---	---	1.74E-06
Cu-64	---	8.33E-08	3.91E-08	---	2.10E-07	---	7.10E-06
Zn-65	4.84E-06	1.54E-05	6.96E-06	---	1.03E-05	---	9.70E-06
Zn-69	1.03E-08	1.97E-08	1.37E-09	---	1.28E-08	---	2.96E-09
Br-83	---	---	4.02E-08	---	---	---	5.79E-08
Br-84	---	---	5.21E-08	---	---	---	4.09E-13
Br-85	---	---	2.14E-09	---	---	---	---
Rb-86	---	2.11E-05	9.83E-06	---	---	---	4.16E-06
Rb-88	---	6.05E-08	3.21E-08	---	---	---	8.36E-19
Rb-89	---	4.01E-08	2.82E-08	---	---	---	2.33E-21
Sr-89	3.08E-04	---	8.84E-06	---	---	---	4.94E-05
Sr-90	8.71E-03	---	1.75E-04	---	---	---	2.19E-04
Sr-91	5.67E-06	---	2.29E-07	---	---	---	2.70E-05
Sr-92	2.15E-06	---	9.30E-08	---	---	---	4.26E-05
Y-90	9.62E-09	---	2.58E-10	---	---	---	1.02E-04
Y-91M	9.09E-11	---	3.52E-12	---	---	---	2.67E-10
Y-91	1.41E-07	---	3.77E-09	---	---	---	7.76E-05
Y-92	8.45E-10	---	2.47E-11	---	---	---	1.48E-05
Y-93	2.68E-09	---	7.40E-11	---	---	---	8.50E-05
Zr-95	3.04E-08	9.75E-09	6.60E-09	---	1.53E-08	---	3.09E-05
Zr-97	1.68E-09	3.39E-10	1.55E-10	---	5.12E-10	---	1.05E-04
Nb-95	6.22E-09	3.46E-09	1.86E-09	---	3.42E-09	---	2.10E-05
Mo-99	---	4.31E-06	8.20E-07	---	9.76E-06	---	9.99E-06
Tc-99M	2.47E-10	6.98E-10	8.89E-09	---	1.06E-08	3.42E-10	4.13E-07

Table 13 - Ingestion Dose Factors for Adult
(mrem per pCi Ingested)

Nuclide	Bone	Liver	T. Body	Thyroid	Kidney	Lung	GI-LLI
Tc-101	2.54E-10	3.66E-10	3.59E-09	---	6.59E-09	1.87E-10	1.10E-21
Ru-103	1.85E-07	---	7.97E-08	---	7.06E-07	---	2.16E-05
Ru-105	1.54E-08	---	6.08E-09	---	1.99E-07	---	9.42E-06
Ru-106	2.75E-06	---	3.48E-07	---	5.31E-06	---	1.78E-04
Ag-110M	1.60E-07	1.48E-07	8.79E-08	---	2.91E-07	---	6.04E-05
Sb-124	2.80E-06	5.29E-08	1.11E-06	6.79E-09	---	2.18E-06	7.95E-05
Sb-125	1.79E-06	2.00E-08	4.26E-07	1.82E-09	---	1.38E-06	1.97E-05
Te-125M	2.68E-06	9.71E-07	3.59E-07	8.06E-07	1.09E-05	---	1.07E-05
Te-127M	6.77E-06	2.42E-06	8.25E-07	1.73E-06	2.75E-05	---	2.27E-05
Te-127	1.10E-07	3.95E-08	2.38E-08	8.15E-08	4.48E-07	---	8.68E-06
Te-129M	1.15E-05	4.29E-06	1.82E-06	3.95E-06	4.80E-05	---	5.79E-05
Te-129	3.14E-08	1.18E-08	7.65E-09	2.41E-08	1.32E-07	---	2.37E-08
Te-131M	1.73E-06	8.46E-07	7.05E-07	1.34E-06	8.57E-06	---	8.40E-05
Te-131	1.97E-08	8.23E-09	6.22E-09	1.62E-08	8.63E-08	---	2.79E-09
Te-132	2.52E-06	1.63E-06	1.53E-06	1.80E-06	1.57E-05	---	7.71E-05
I-130	7.56E-07	2.23E-06	8.80E-07	1.89E-04	3.48E-06	---	1.92E-06
I-131	4.16E-06	5.95E-06	3.41E-06	1.95E-03	1.02E-05	---	1.57E-06
I-132	2.03E-07	5.43E-07	1.90E-07	1.90E-05	8.65E-07	---	1.02E-07
I-133	1.42E-06	2.47E-06	7.53E-07	3.63E-04	4.31E-06	---	2.22E-06
I-134	1.06E-07	2.88E-07	1.03E-07	4.99E-06	4.58E-07	---	2.51E-10
I-135	4.43E-07	1.16E-06	4.28E-07	7.65E-05	1.86E-06	---	1.31E-06
Cs-134	6.22E-05	1.48E-04	1.21E-04	---	4.79E-05	1.59E-05	2.59E-06
Cs-136	6.51E-06	2.57E-05	1.85E-05	---	1.43E-05	1.96E-06	2.92E-06
Cs-137	7.97E-05	1.09E-04	7.14E-05	---	3.70E-05	1.23E-05	2.11E-06
Cs-138	5.52E-08	1.09E-07	5.40E-08	---	8.01E-08	7.91E-09	4.65E-13
Ba-139	9.70E-08	6.91E-11	2.84E-09	---	6.46E-11	3.92E-11	1.72E-07
Ba-140	2.03E-05	2.55E-08	1.33E-06	---	8.67E-09	1.46E-08	4.18E-05
Ba-141	4.71E-08	3.56E-11	1.59E-09	---	3.31E-11	2.02E-11	2.22E-17
Ba-142	2.13E-08	2.19E-11	1.34E-09	---	1.85E-11	1.24E-11	3.00E-26
La-140	2.50E-09	1.26E-09	3.33E-10	---	---	---	9.25E-05
La-142	1.28E-10	5.82E-11	1.45E-11	---	---	---	4.25E-07
Ce-141	9.36E-09	6.33E-09	7.18E-10	---	2.94E-09	---	2.42E-05
Ce-143	1.65E-09	1.22E-06	1.35E-10	---	5.37E-10	---	4.56E-05
Ce-144	4.88E-07	2.04E-07	2.62E-08	---	1.21E-07	---	1.65E-04
Pr-143	9.20E-09	3.69E-09	4.56E-10	---	2.13E-09	---	4.03E-05
Pr-144	3.01E-11	1.25E-11	1.53E-12	---	7.05E-12	---	4.33E-18
Nd-147	6.29E-09	7.27E-09	4.35E-10	---	4.25E-09	---	3.49E-05

Table 13 - Ingestion Dose Factors for Adult
(mrem per pCi Ingested)

Nuclide	Bone	Liver	T. Body	Thyroid	Kidney	Lung	GI-LLI
W-187	1.03E-07	8.61E-08	3.01E-08	---	---	---	2.82E-05
Pu-238	6.30E-04	7.98E-05	1.71E-05	---	7.32E-05	---	7.30E-05
Pu-239	7.25E-04	8.71E-05	1.91E-05	---	8.11E-05	---	6.66E-05
Pu-240	7.24E-04	8.70E-05	1.91E-05	---	8.10E-05	---	6.78E-05
Pu-241	1.57E-05	7.45E-07	3.32E-07	---	1.53E-06	---	1.40E-06
Np-239	1.19E-09	1.17E-10	6.45E-11	---	3.65E-10	---	2.40E-05
Am-241	7.55E-04	7.05E-04	5.41E-05	---	4.07E-04	---	7.42E-05
Cm-242	2.06E-05	2.19E-05	1.37E-06	---	6.22E-06	---	7.92E-05
Cm-243	5.99E-04	5.49E-04	3.75E-05	---	1.75E-04	---	7.81E-05
Cm-244	4.56E-04	4.27E-04	2.87E-05	---	1.34E-04	---	7.55E-05

Table 14 - Ingestion Dose Factors for Teenager
(mrem per pCi Ingested)

Nuclide	Bone	Liver	T. Body	Thyroid	Kidney	Lung	GI-LLI
H-3	--	6.04E-08	6.04E-08	6.04E-08	6.04E-08	6.04E-08	6.04E-08
C-14	4.06E-06	8.12E-07	8.12E-07	8.12E-07	8.12E-07	8.12E-07	8.12E-07
Na-24	2.30E-06	2.30E-06	2.30E-06	2.30E-06	2.30E-06	2.30E-06	2.30E-06
P-32	2.76E-04	1.71E-05	1.07E-05	---	---	---	2.32E-05
Cr-51	---	---	3.60E-09	2.00E-09	7.89E-10	5.14E-09	6.05E-07
Mn-54	---	5.90E-06	1.17E-06	---	1.76E-06	---	1.21E-05
Mn-56	---	1.58E-07	2.81E-08	---	2.00E-07	---	1.04E-05
Fe-55	3.78E-06	2.68E-06	6.25E-07	---	---	1.70E-06	1.16E-06
Fe-59	5.87E-06	1.37E-05	5.29E-06	---	---	4.32E-06	3.24E-05
Co-58	---	9.72E-07	2.24E-06	---	---	---	1.34E-05
Co-60	---	2.81E-06	6.33E-06	---	---	---	3.66E-05
Ni-59	1.32E-05	4.66E-06	2.24E-06	---	---	---	7.31E-07
Ni-63	1.77E-04	1.25E-05	6.00E-06	---	---	---	1.99E-06
Ni-65	7.49E-07	9.57E-08	4.36E-08	---	---	---	5.19E-06
Cu-64	---	1.15E-07	5.41E-08	---	2.91E-07	---	8.92E-06
Zn-65	5.76E-06	2.00E-05	9.33E-06	---	1.28E-05	---	8.47E-06
Zn-69	1.47E-08	2.80E-08	1.96E-09	---	1.83E-08	---	5.16E-08
Br-83	---	---	5.74E-08	---	---	---	---
Br-84	---	---	7.22E-08	---	---	---	---
Br-85	---	---	3.05E-09	---	---	---	---
Rb-86	---	2.98E-05	1.40E-05	---	---	---	4.41E-06
Rb-88	---	8.52E-08	4.54E-08	---	---	---	7.30E-15
Rb-89	---	5.50E-08	3.89E-08	---	---	---	8.43E-17
Sr-89	4.40E-04	---	1.26E-05	---	---	---	5.24E-05
Sr-90	1.02E-02	---	2.04E-04	---	---	---	2.33E-04
Sr-91	8.07E-06	---	3.21E-07	---	---	---	3.66E-05
Sr-92	3.05E-06	---	1.30E-07	---	---	---	7.77E-05
Y-90	1.37E-08	---	3.69E-10	---	---	---	1.13E-04
Y-91M	1.29E-10	---	4.93E-12	---	---	---	6.09E-09
Y-91	2.01E-07	---	5.39E-09	---	---	---	8.24E-05
Y-92	1.21E-09	---	3.50E-11	---	---	---	3.32E-05
Y-93	3.83E-09	---	1.05E-10	---	---	---	1.17E-04
Zr-95	4.12E-08	1.30E-08	8.94E-09	---	1.91E-08	---	3.00E-05
Zr-97	2.37E-09	4.69E-10	2.16E-10	---	7.11E-10	---	1.27E-04
Nb-95	8.22E-09	4.56E-09	2.51E-09	---	4.42E-09	---	1.95E-05
Mo-99	---	6.03E-06	1.15E-06	---	1.38E-05	---	1.08E-05
Tc-99M	3.32E-10	9.26E-10	1.20E-08	---	1.38E-08	5.14E-10	6.08E-07

Table 14 - Ingestion Dose Factors for Teenager
(mrem per pCi Ingested)

Nuclide	Bone	Liver	T. Body	Thyroid	Kidney	Lung	GI-LLI
Tc-101	3.60E-10	5.12E-10	5.03E-09	---	9.26E-09	3.12E-10	8.75E-17
Ru-103	2.55E-07	---	1.09E-07	---	8.99E-07	---	2.13E-05
Ru-105	2.18E-08	---	8.46E-09	---	2.75E-07	---	1.76E-05
Ru-106	3.92E-06	---	4.94E-07	---	7.56E-06	---	1.88E-04
Ag-110M	2.05E-07	1.94E-07	1.18E-07	---	3.70E-07	---	5.45E-05
Sb-124	3.87E-06	7.13E-08	1.51E-06	8.78E-09	---	3.38E-06	7.80E-05
Sb-125	2.48E-06	2.71E-08	5.80E-07	2.37E-09	---	2.18E-06	1.93E-05
Te-125M	3.83E-06	1.38E-06	5.12E-07	1.07E-06	---	---	1.13E-05
Te-127M	9.67E-06	3.43E-06	1.15E-06	2.30E-06	3.92E-05	---	2.41E-05
Te-127	1.58E-07	5.60E-08	3.40E-08	1.09E-07	6.40E-07	---	1.22E-05
Te-129M	1.63E-05	6.05E-06	2.58E-06	5.26E-06	6.82E-05	---	6.12E-05
Te-129	4.48E-08	1.67E-08	1.09E-08	3.20E-08	1.88E-07	---	2.45E-07
Te-131M	2.44E-06	1.17E-06	9.76E-07	1.76E-06	1.22E-05	---	9.39E-05
Te-131	2.79E-08	1.15E-08	8.72E-09	2.15E-08	1.22E-07	---	2.29E-09
Te-132	3.49E-06	2.21E-06	2.08E-06	2.33E-06	2.12E-05	---	7.00E-05
I-130	1.03E-06	2.98E-06	1.19E-06	2.43E-04	4.59E-06	---	2.29E-06
I-131	5.85E-06	8.19E-06	4.40E-06	2.39E-03	1.41E-05	---	1.62E-06
I-132	2.79E-07	7.30E-07	2.62E-07	2.46E-05	1.15E-06	---	3.18E-07
I-133	2.01E-06	3.41E-06	1.04E-06	4.76E-04	5.98E-06	---	2.58E-06
I-134	1.46E-07	3.87E-07	1.39E-07	6.45E-06	6.10E-07	---	5.10E-09
I-135	6.10E-07	1.57E-06	5.82E-07	1.01E-04	2.48E-06	---	1.74E-06
Cs-134	8.37E-05	1.97E-04	9.14E-05	---	6.26E-05	2.39E-05	2.45E-06
Cs-136	8.59E-06	3.38E-05	2.27E-05	---	1.84E-05	2.90E-06	2.72E-06
Cs-137	1.12E-04	1.49E-04	5.19E-05	---	5.07E-05	1.97E-05	2.12E-06
Cs-138	7.76E-08	1.49E-07	7.45E-08	---	1.10E-07	1.28E-08	4.76E-11
Ba-139	1.39E-07	9.78E-11	4.05E-09	---	9.22E-11	6.74E-11	1.24E-06
Ba-140	2.84E-05	3.48E-08	1.83E-06	---	1.18E-08	2.34E-08	4.38E-05
Ba-141	6.71E-08	5.01E-11	2.24E-09	---	4.65E-11	3.43E-11	1.43E-13
Ba-142	2.99E-08	2.99E-11	1.84E-09	---	2.53E-11	1.99E-11	9.18E-20
La-140	3.48E-09	1.71E-09	4.55E-10	---	---	---	9.28E-05
La-142	1.79E-10	7.95E-11	1.98E-11	---	---	---	2.42E-06
Ce-141	1.33E-08	8.88E-09	1.02E-09	---	4.18E-09	---	2.54E-05
Ce-143	2.35E-09	1.71E-06	1.91E-10	---	7.67E-10	---	5.14E-05
Ce-144	6.96E-07	2.88E-07	3.74E-08	---	1.72E-07	---	1.75E-04
Pr-143	1.31E-08	5.23E-09	6.52E-10	---	3.04E-09	---	4.31E-05
Pr-144	4.30E-11	1.76E-11	2.18E-12	---	1.01E-11	---	4.74E-14
Nd-147	9.38E-09	1.02E-08	6.11E-10	---	5.99E-09	---	3.68E-05

Table 14 - Ingestion Dose Factors for Teenager
(mrem per pCi Ingested)

Nuclide	Bone	Liver	T. Body	Thyroid	Kidney	Lung	GI-LLI
W-187	1.46E-07	1.19E-07	4.17E-08	---	---	---	3.22E-05
Pu-238	6.70E-04	8.58E-05	1.82E-05	---	7.80E-05	---	7.73E-05
Pu-239	7.65E-04	9.29E-05	2.01E-05	---	8.57E-05	---	7.06E-05
Pu-240	7.64E-04	9.27E-05	2.01E-05	---	8.56E-05	---	7.19E-05
Pu-241	1.75E-05	8.40E-07	3.69E-07	---	1.71E-06	---	1.48E-06
Np-239	1.76E-09	1.66E-10	9.22E-11	---	5.21E-10	---	2.67E-05
Am-241	7.98E-04	7.53E-04	5.75E-05	---	4.31E-04	---	7.87E-05
Cm-242	2.94E-05	3.10E-05	1.95E-06	---	8.89E-06	---	8.40E-05
Cm-243	6.50E-04	6.03E-04	4.09E-05	---	1.91E-04	---	8.28E-05
Cm-244	5.04E-04	4.77E-04	3.19E-05	---	1.49E-04	---	8.00E-05

Table 15 - Ingestion Dose Factors for Child
(mrem per pCi Ingested)

Nuclide	Bone	Liver	T. Body	Thyroid	Kidney	Lung	GI-LLI
H-3	---	1.16E-07	1.16E-07	1.16E-07	1.16E-07	1.16E-07	1.16E-07
C-14	1.21E-05	2.42E-06	2.42E-06	2.42E-06	2.42E-06	2.42E-06	2.42E-06
Na-24	5.80E-06	5.80E-06	5.80E-06	5.80E-06	5.80E-06	5.80E-06	5.80E-06
P-32	8.25E-04	3.86E-05	3.18E-05	---	---	---	2.28E-05
Cr-51	---	---	8.90E-09	4.94E-09	1.35E-09	9.02E-09	4.72E-07
Mn-54	---	1.07E-05	2.85E-06	---	3.00E-06	---	8.98E-06
Mn-56	---	3.34E-07	7.54E-08	---	4.04E-07	---	4.84E-05
Fe-55	1.15E-05	6.10E-06	1.89E-06	---	---	3.45E-06	1.13E-06
Fe-59	1.65E-05	2.67E-05	1.33E-05	---	---	7.74E-06	2.78E-05
Co-58	---	1.80E-06	5.51E-06	---	---	---	1.05E-05
Co-60	---	5.29E-06	1.56E-05	---	---	---	2.93E-05
Ni-59	4.02E-05	1.07E-05	6.82E-06	---	---	---	7.10E-07
Ni-63	5.38E-04	2.88E-05	1.83E-05	---	---	---	1.94E-06
Ni-65	2.22E-06	2.09E-07	1.22E-07	---	---	---	2.56E-05
Cu-64	---	2.45E-07	1.48E-07	---	5.92E-07	---	1.15E-05
Zn-65	1.37E-05	3.65E-05	2.27E-05	---	2.30E-05	---	6.41E-06
Zn-69	4.38E-08	6.33E-08	5.85E-09	---	3.84E-08	---	3.99E-06
Br-83	---	---	1.71E-07	---	---	---	---
Br-84	---	---	1.98E-07	---	---	---	---
Br-85	---	---	9.12E-09	---	---	---	---
Rb-86	---	6.70E-05	4.12E-05	---	---	---	4.31E-06
Rb-88	---	1.90E-07	1.32E-07	---	---	---	9.32E-09
Rb-89	---	1.17E-07	1.04E-07	---	---	---	1.02E-09
Sr-89	1.32E-03	---	3.77E-05	---	---	---	5.11E-05
Sr-90	2.56E-02	---	5.15E-04	---	---	---	2.29E-04
Sr-91	2.40E-05	---	9.06E-07	---	---	---	5.30E-05
Sr-92	9.03E-06	---	3.62E-07	---	---	---	1.71E-04
Y-90	4.11E-08	---	1.10E-09	---	---	---	1.17E-04
Y-91M	3.82E-10	---	1.39E-11	---	---	---	7.48E-07
Y-91	6.02E-07	---	1.61E-08	---	---	---	8.02E-05
Y-92	3.60E-09	---	1.03E-10	---	---	---	1.04E-04
Y-93	1.14E-08	---	3.13E-10	---	---	---	1.70E-04
Zr-95	1.16E-07	2.55E-08	2.27E-08	---	3.65E-08	---	2.66E-05
Zr-97	6.99E-09	1.01E-09	5.96E-10	---	1.45E-09	---	1.53E-04
Nb-95	2.25E-08	8.76E-09	6.26E-09	---	8.23E-09	---	1.62E-05
Mo-99	---	1.33E-05	3.29E-06	---	2.84E-05	---	1.10E-05
Tc-99M	9.23E-10	1.81E-09	3.00E-08	---	2.63E-08	9.19E-10	1.03E-06

Table 15 - Ingestion Dose Factors for Child
(mrem per pCi Ingested)

Nuclide	Bone	Liver	T. Body	Thyroid	Kidney	Lung	GI-LLI
Tc-101	1.07E-09	1.12E-09	1.42E-08	---	1.91E-08	5.92E-10	3.56E-09
Ru-103	7.31E-07	---	2.81E-07	---	1.84E-06	---	1.89E-05
Ru-105	6.45E-08	---	2.34E-08	---	5.67E-07	---	4.21E-05
Ru-106	1.17E-05	---	1.46E-06	---	1.58E-05	---	1.82E-04
Ag-110M	5.39E-07	3.64E-07	2.91E-07	---	6.78E-07	---	4.33E-05
Sb-124	1.11E-05	1.44E-07	3.89E-06	2.45E-08	---	6.16E-06	6.94E-05
Sb-125	7.16E-06	5.52E-08	1.50E-06	6.63E-09	---	3.99E-06	1.71E-05
Te-125M	1.14E-05	3.09E-06	1.52E-06	3.20E-06	---	---	1.10E-05
Te-127M	2.89E-05	7.78E-06	3.43E-06	6.91E-06	8.24E-05	---	2.34E-05
Te-127	4.71E-07	1.27E-07	1.01E-07	3.26E-07	1.34E-06	---	1.84E-05
Te-129M	4.87E-05	1.36E-05	7.56E-06	1.57E-05	1.43E-04	---	5.94E-05
Te-129	1.34E-07	3.74E-08	3.18E-08	9.56E-08	3.92E-07	---	8.34E-06
Te-131M	7.20E-06	2.49E-06	2.65E-06	5.12E-06	2.41E-05	---	1.01E-04
Te-131	8.30E-08	2.53E-08	2.47E-08	6.35E-08	2.51E-07	---	4.36E-07
Te-132	1.01E-05	4.47E-06	5.40E-06	6.51E-06	4.15E-05	---	4.50E-05
I-130	2.92E-06	5.90E-06	3.04E-06	6.50E-04	8.82E-06	---	2.76E-06
I-131	1.72E-05	1.73E-05	9.83E-06	5.72E-03	2.84E-05	---	1.54E-06
I-132	8.00E-07	1.47E-06	6.76E-07	6.82E-05	2.25E-06	---	1.73E-06
I-133	5.92E-06	7.32E-06	2.77E-06	1.36E-03	1.22E-05	---	2.95E-06
I-134	4.19E-07	7.78E-07	3.58E-07	1.79E-05	1.19E-06	---	5.16E-07
I-135	1.75E-06	3.15E-06	1.49E-06	2.79E-04	4.83E-06	---	2.40E-06
Cs-134	2.34E-04	3.84E-04	8.10E-05	---	1.19E-04	4.27E-05	2.07E-06
Cs-136	2.35E-05	6.46E-05	4.18E-05	---	3.44E-05	5.13E-06	2.27E-06
Cs-137	3.27E-04	3.13E-04	4.62E-05	---	1.02E-04	3.67E-05	1.96E-06
Cs-138	2.28E-07	3.17E-07	2.01E-07	---	2.23E-07	2.40E-08	1.46E-07
Ba-139	4.14E-07	2.21E-10	1.20E-08	---	1.93E-10	1.30E-10	2.39E-05
Ba-140	8.31E-05	7.28E-08	4.85E-06	---	2.37E-08	4.34E-08	4.21E-05
Ba-141	2.00E-07	1.12E-10	6.51E-09	---	9.69E-11	6.58E-10	1.14E-07
Ba-142	8.74E-08	6.29E-11	4.88E-09	---	5.09E-11	3.70E-11	1.14E-09
La-140	1.01E-08	3.53E-09	1.19E-09	---	---	---	9.84E-05
La-142	5.24E-10	1.67E-10	5.23E-11	---	---	---	3.31E-05
Ce-141	3.97E-08	1.98E-08	2.94E-09	---	8.68E-09	---	2.47E-05
Ce-143	6.99E-09	3.79E-06	5.49E-10	---	1.59E-09	---	5.55E-05
Ce-144	2.08E-06	6.52E-07	1.11E-07	---	3.61E-07	---	1.70E-04
Pr-143	3.93E-08	1.18E-08	1.95E-09	---	6.39E-09	---	4.24E-05
Pr-144	1.29E-10	3.99E-11	6.49E-12	---	2.11E-11	---	8.59E-08
Nd-147	2.79E-08	2.26E-08	1.75E-09	---	1.24E-08	---	3.58E-05

Table 15 - Ingestion Dose Factors for Child
(mrem per pCi Ingested)

Nuclide	Bone	Liver	T. Body	Thyroid	Kidney	Lung	GI-LLI
W-187	4.29E-07	2.54E-07	1.14E-07	---	---	---	3.57E-05
Pu-238	1.19E-03	1.38E-04	3.16E-05	---	1.15E-04	---	7.50E-05
Pu-239	1.29E-03	1.38E-04	3.31E-05	---	1.22E-04	---	6.85E-05
Pu-240	1.28E-03	1.43E-04	3.31E-05	---	1.22E-04	---	6.98E-05
Pu-241	3.87E-05	1.58E-06	8.04E-07	---	2.96E-06	---	1.44E-06
Np-239	5.25E-09	3.77E-10	2.65E-10	---	1.09E-09	---	2.79E-05
Am-241	1.36E-03	1.17E-03	1.02E-04	---	6.23E-04	---	7.64E-05
Cm-242	8.78E-05	7.01E-05	5.84E-06	---	1.87E-05	---	8.16E-05
Cm-243	1.28E-03	1.04E-03	8.24E-05	---	3.08E-04	---	8.03E-05
Cm-244	1.08E-03	8.74E-04	6.93E-05	---	2.54E-04	---	7.77E-05

Table 16 - Ingestion Dose Factors for Infant
(mrem per pCi Ingested)

Nuclide	Bone	Liver	T. Body	Thyroid	Kidney	Lung	GI-LLI
H-3	---	1.76E-07	1.76E-07	1.76E-07	1.76E-07	1.76E-07	1.76E-07
C-14	2.37E-05	5.06E-06	5.06E-06	5.06E-06	5.06E-06	5.06E-06	5.06E-06
Na-24	1.01E-05	1.01E-05	1.01E-05	1.01E-05	1.01E-05	1.01E-05	1.01E-05
P-32	1.70E-03	1.00E-04	6.59E-05	---	---	---	2.30E-05
Cr-51	---	---	1.41E-08	9.20E-09	2.01E-09	1.79E-08	4.11E-07
Mn-54	---	1.99E-05	4.51E-06	---	4.41E-06	---	7.31E-06
Mn-56	---	8.18E-07	1.41E-07	---	7.03E-07	---	7.43E-05
Fe-55	1.39E-05	8.98E-06	2.40E-06	---	---	4.36E-06	1.14E-06
Fe-59	3.08E-05	5.38E-05	2.12E-05	---	---	1.59E-05	2.57E-05
Co-58	---	3.60E-06	8.98E-06	---	---	---	8.97E-06
Co-60	---	1.08E-05	2.55E-05	---	---	---	2.57E-05
Ni-59	4.73E-05	1.45E-05	8.17E-06	---	---	---	7.16E-07
Ni-63	6.34E-04	3.92E-05	2.20E-05	---	---	---	1.95E-06
Ni-65	4.70E-06	5.32E-07	2.42E-07	---	---	---	4.05E-05
Cu-64	---	6.09E-07	2.82E-07	---	1.03E-06	---	1.25E-05
Zn-65	1.84E-05	6.31E-05	2.91E-05	---	3.06E-05	---	5.33E-05
Zn-69	9.33E-08	1.68E-07	1.25E-08	---	6.98E-08	---	1.37E-05
Br-83	---	---	3.63E-07	---	---	---	---
Br-84	---	---	3.82E-07	---	---	---	---
Br-85	---	---	1.94E-08	---	---	---	---
Rb-86	---	1.70E-04	8.40E-05	---	---	---	4.35E-06
Rb-88	---	4.98E-07	2.73E-07	---	---	---	4.85E-07
Rb-89	---	2.86E-07	1.97E-07	---	---	---	9.74E-08
Sr-89	2.51E-03	---	7.20E-05	---	---	---	5.16E-05
Sr-90	2.83E-02	---	5.74E-04	---	---	---	2.31E-04
Sr-91	5.00E-05	---	1.81E-06	---	---	---	5.92E-05
Sr-92	1.92E-05	---	7.13E-07	---	---	---	2.07E-04
Y-90	8.69E-08	---	2.33E-09	---	---	---	1.20E-04
Y-91M	8.10E-10	---	2.76E-11	---	---	---	2.70E-06
Y-91	1.13E-06	---	3.01E-08	---	---	---	8.10E-05
Y-92	7.65E-09	---	2.15E-10	---	---	---	1.46E-04
Y-93	2.43E-08	---	6.62E-10	---	---	---	1.92E-04
Zr-95	2.06E-07	5.02E-08	3.56E-08	---	5.41E-08	---	2.50E-05
Zr-97	1.48E-08	2.54E-09	1.16E-09	---	2.56E-09	---	1.62E-04
Nb-95	4.20E-08	1.73E-08	1.00E-08	---	1.24E-08	---	1.46E-05
Mo-99	---	3.40E-05	6.63E-06	---	5.08E-05	---	1.12E-05
Tc-99M	1.92E-09	3.96E-09	5.10E-08	---	4.26E-08	2.07E-09	1.15E-06

Table 16 - Ingestion Dose Factors for Infant
(mrem per pCi Ingested)

Nuclide	Bone	Liver	T. Body	Thyroid	Kidney	Lung	GI-LLI
Tc-101	2.27E-09	2.86E-09	2.83E-08	---	3.40E-08	1.56E-09	4.86E-07
Ru-103	1.48E-06	---	4.95E-07	---	3.08E-06	---	1.80E-05
Ru-105	1.36E-07	---	4.58E-08	---	1.00E-06	---	5.41E-05
Ru-106	2.41E-05	---	3.01E-06	---	2.85E-05	---	1.83E-04
Ag-110M	9.96E-07	7.27E-07	4.81E-07	---	1.04E-06	---	3.77E-05
Sb-124	2.14E-05	3.15E-07	6.63E-06	5.68E-08	---	1.34E-05	6.60E-05
Sb-125	1.23E-05	1.19E-07	2.53E-06	1.54E-08	---	7.12E-06	1.64E-05
Te-125M	2.33E-05	7.79E-06	3.15E-06	7.84E-06	---	---	1.11E-05
Te-127M	5.85E-05	1.94E-05	7.08E-06	1.69E-05	1.44E-04	---	2.36E-05
Te-127	1.00E-06	3.35E-07	2.15E-07	8.14E-07	2.44E-06	---	2.10E-05
Te-129M	1.00E-04	3.43E-05	1.54E-05	3.84E-05	2.50E-04	---	5.97E-05
Te-129	2.84E-07	9.79E-08	6.63E-08	2.38E-07	7.07E-07	---	2.27E-05
Te-131M	1.52E-05	6.12E-06	5.05E-06	1.24E-05	4.21E-05	---	1.03E-04
Te-131	1.76E-07	6.50E-08	4.94E-08	1.57E-07	4.50E-07	---	7.11E-06
Te-132	2.08E-05	1.03E-05	9.61E-06	1.52E-05	6.44E-05	---	3.81E-05
I-130	6.00E-06	1.32E-05	5.30E-06	1.48E-03	1.45E-05	---	2.83E-06
I-131	3.59E-05	4.23E-05	1.86E-05	1.39E-02	4.94E-05	---	1.51E-06
I-132	1.66E-06	3.37E-06	1.20E-06	1.58E-04	3.76E-06	---	2.73E-06
I-133	1.25E-05	1.82E-05	5.33E-06	3.31E-03	2.14E-05	---	3.08E-06
I-134	8.69E-07	1.78E-06	6.33E-07	4.15E-05	1.99E-06	---	1.84E-06
I-135	3.64E-06	7.24E-06	2.64E-06	6.49E-04	8.07E-06	---	2.62E-06
Cs-134	3.77E-04	7.03E-04	7.10E-05	---	1.81E-04	7.42E-05	1.91E-06
Cs-136	4.59E-05	1.35E-04	5.04E-05	---	5.38E-05	1.10E-05	2.05E-06
Cs-137	5.22E-04	6.11E-04	4.33E-05	---	1.64E-04	6.64E-05	1.91E-06
Cs-138	4.81E-07	7.82E-07	3.79E-07	---	3.90E-07	6.09E-08	1.25E-06
Ba-139	8.81E-07	5.84E-10	2.55E-08	---	3.51E-10	3.54E-10	5.58E-05
Ba-140	1.71E-04	1.71E-07	8.81E-06	---	4.06E-08	1.05E-07	4.20E-05
Ba-141	4.25E-07	2.91E-10	1.34E-08	---	1.75E-10	1.77E-10	5.19E-06
Ba-142	1.84E-07	1.53E-10	9.06E-09	---	8.81E-11	9.26E-11	7.59E-07
La-140	2.11E-08	8.32E-09	2.14E-09	---	---	---	9.77E-05
La-142	1.10E-09	4.04E-10	9.67E-11	---	---	---	6.86E-05
Ce-141	7.87E-08	4.80E-08	5.65E-09	---	1.48E-08	---	2.48E-05
Ce-143	1.48E-08	9.82E-06	1.12E-09	---	2.86E-09	---	5.73E-05
Ce-144	2.98E-06	1.22E-06	1.67E-07	---	4.93E-07	---	1.71E-04
Pr-143	8.13E-08	3.04E-08	4.03E-09	---	1.13E-08	---	4.29E-05
Pr-144	2.74E-10	1.06E-10	1.38E-11	---	3.84E-11	---	4.93E-06
Nd-147	5.53E-08	5.68E-08	3.48E-09	---	2.19E-08	---	3.60E-05

Table 16 - Ingestion Dose Factors for Infant
(mrem per pCi Ingested)

Nuclide	Bone	Liver	T. Body	Thyroid	Kidney	Lung	GI-LLI
W-187	9.03E-07	6.28E-07	2.17E-07	---	---	---	3.69E-05
Pu-238	1.28E-03	1.50E-04	3.40E-05	---	1.21E-04	---	7.57E-05
Pu-239	1.38E-03	1.55E-04	3.54E-05	---	1.28E-04	---	6.91E-05
Pu-240	1.38E-03	1.55E-04	3.54E-05	---	1.28E-04	---	7.04E-05
Pu-241	4.25E-05	1.76E-06	8.82E-07	---	3.17E-06	---	1.45E-06
Np-239	1.11E-08	9.93E-10	5.61E-10	---	1.98E-09	---	2.87E-05
Am-241	1.46E-03	1.27E-03	1.09E-04	---	6.55E-04	---	7.70E-05
Cm-242	1.37E-04	1.27E-04	9.10E-06	---	2.62E-05	---	8.23E-05
Cm-243	1.40E-03	1.15E-03	8.98E-05	---	3.27E-04	---	8.10E-05
Cm-244	1.18E-03	9.70E-04	7.59E-05	---	2.71E-04	---	7.84E-05

Table 17 - Recommended Values for Other Parameters

Parameter Symbol	Definition	Values
f_g	Fraction of ingested produce grown in garden of interest.	0.76
f_p	Fraction of leafy vegetables grown in garden of interest.	1.0
P	Effective surface density of soil (assumes a 15 cm plow layer, expressed in dry weight)	240 kg/m ²
r	Fraction of deposited activity retained on crops, leafy vegetables, or pasture grass	0.25 1.0 (iodines) 0.2 (other particulates)
S_r	Attenuation factor accounting for shielding provided by residential structures	0.7 (maximum individual) 0.5 (general population)
t_b	Period of long-term buildup for activity in sediment or soil (20 years)	1.752E5 hr
t_e	Period of crop, leafy vegetable, or pasture grass exposure during growing season	30 days (grass-cow-milk-man pathway) 60 days (crop/vegetation-man pathway)
t_r	Transport time from animal feed-milk-man provided by residential structures	2 days (maximum individual) 4 days (general population)
t_h	Time delay between harvest of vegetation or crops and ingestion:	
	• For ingestion of forage by animals	Zero (pasture grass) 90 days (stored feed)
	• For ingestion of crops by man	1 day (leafy vegetables and max. individual feed) 60 days (produce and max. individual) 14 days (general population)
f_s	The fraction of daily feed that is pasture grass while the animals graze on pasture.	1.0
M_p	The mixing ratio at the point of withdrawal of drinking water.	Site Discharge 7.14 M.U.D. Intake 30.8
f_p	Fraction of the year that animals graze on pasture.	0.5

Table 17 - Recommended Values for Other Parameters

Parameter Symbol	Definition	Values
t_p	Environmental transit time, release to receptor (add time from release to exposure individual point to minimums shown for distribution)	12 hrs. (maximum) 1 day (maximum individual) 1 day (general population) 7 days (population--sport fish doses) 10 days (population--commercial fish doses)
t_s	Average time from slaughter of meat animal to consumption	20 days
Y_v	Agricultural productivity by unit area (measured in wet weight)	0.7 kg/m ² (grass-cow-milk-man pathway) 2.0 kg/m ² (produce or leafy vegetable ingested by man)
W	Shore-width factor for river shoreline	0.2
λ_w	Rate constant for removal of activity on plant or leaf structures by weathering (corresponds to a 14-day half-life)	0.0021 hr ⁻¹

CH-ODCM-0001

Off-Site Dose Calculation Manual (ODCM)

Revision 33

Safety Classification:

Non-Safety

Usage Level:

Reference

Change No.:	EC 70444
Reason for Change:	Change SRC to ISR and X/Q change for Historical Met Data
Preparer:	J. Hoffman

Fort Calhoun Station

Table of Contents

PART I

1.0	PURPOSE AND SCOPE.....	6
1.1	Purpose.....	6
1.2	Scope.....	6
2.0	DEFINITIONS.....	6
3.0	INSTRUMENTATION.....	10
3.1	Radioactive Liquid Effluent Instrumentation.....	10
3.2	Radioactive Gaseous Effluent Instrumentation.....	13
4.0	RADIOACTIVE EFFLUENTS.....	17
4.1	Radioactive Liquid Effluents.....	17
4.2	Radioactive Gaseous Effluents.....	23
4.3	Uranium Fuel Cycle.....	29
5.0	RADIOLOGICAL ENVIRONMENTAL MONITORING PROGRAM (REMP).....	30
5.1	Monitoring Program.....	30
5.2	Land Use Survey.....	45
5.3	Interlaboratory Comparison Program.....	46
6.0	ADMINISTRATIVE CONTROLS.....	47
6.1	Responsibilities.....	47
6.2	Radioactive Effluent Reporting Requirements.....	47
6.3	Change Mechanism.....	52
6.4	Meteorological Data.....	52
6.5	References.....	53
7.0	BASIS.....	55
7.1	Instrumentation.....	55
7.2	Radioactive Effluents.....	55
7.3	Radiological Environmental Monitoring.....	60
7.4	Abnormal Release or Abnormal Discharge Reporting.....	61

**List of Tables
PART I**

Table 1.2 - Frequency Notation	8
Table 1.3 - Radiological Effluent Controls Program Technical Specification Implementation..	9
Table 3.1.1 - Radioactive Liquid Effluent Monitoring Instrumentation.....	11
Table 3.1.2 - Radioactive Liquid Effluent Monitoring Instrumentation Surveillance Requirements.....	12
Table 3.2.1 - Radioactive Gaseous Effluent Monitoring Instrumentation	14
Table 3.2.2 - Radioactive Gaseous Effluent Monitoring Instrumentation Surveillance Requirements	16
Table 4.1 - Radioactive Liquid Effluent Sampling and Analysis	19
Table 4.2 - Radioactive Airborne Effluent Sampling and Analysis	24
Table 4.3 - Sampler Deposition/Transportation Correction Factors.....	26
Table 5.1 - Radiological Environmental Monitoring Program.....	32
Table 5.2 - Radiological Environmental Sampling Locations And Media.....	35
Table 5.3 - Detection Capabilities for Environmental Sample Analysis Lower Limit of Detection (LLD)	43
Table 5.4 - Reporting Levels for Radioactivity Concentrations in Environmental Samples	44

**List of Figures
PART I**

Figure 1 – Environmental Radiological Sampling Points	41
Figure 2 – 40CFR190 Sampling Points	42

Table of Contents

PART II

1.0	EFFLUENT MONITOR SETPOINTS.....	64
1.1	Liquid Effluents.....	64
1.2	Airborne Effluents.....	67
2.0	EFFLUENT CONCENTRATIONS	75
2.1	Liquid Effluent Concentrations	75
2.2	Airborne Effluent Concentrations	75
3.0	RADIOACTIVE EFFLUENT DOSE CALCULATIONS	77
3.1	Liquid Effluent Dose Calculations.....	77
3.2	Airborne Effluent Dose Calculations.....	80
4.0	LOWER LIMIT OF DETECTION (LLD).....	93

**List of Tables
PART II**

Table 1 - Deleted	67
Table 2 - Deleted	94
Table 3 - Bioaccumulation Factors	94
Table 4 - Highest Potential Exposure Pathways for Estimating Dose.....	95
Table 5 - Stable Element Transfer Data	96
Table 6 - Recommended Values for U_{ap} to Be Used for the Maximum Exposed Individual in Lieu of Site Specific Data.....	97
Table 7 - Animal Consumption Rates	97
Table 8 - External Dose Factors for Standing on Contaminated Ground.....	98
Table 9 - Inhalation Dose Factors for Adult	101
Table 10 - Inhalation Dose Factors for Teenager	104
Table 11 - Inhalation Dose Factors for Child	107
Table 12 - Inhalation Dose Factors for Infant	110
Table 13 - Ingestion Dose Factors for Adult	113
Table 14 - Ingestion Dose Factors for Teenager	116
Table 15 - Ingestion Dose Factors for Child	119
Table 16 - Ingestion Dose Factors for Infant	122
Table 17 - Recommended Values for Other Parameters.....	125

**List of Figures
PART II**

Figure 1 - Exclusion and Site Boundary Map	68
Figure 2 - Liquid Radioactive Discharge Pathways	69
Figure 3 - Liquid Radioactive Waste Disposal System	70
Figure 4 - Airborne Effluent Discharge Pathways	71
Figure 5 - Airborne Radioactive Waste Disposal System	72

1.0 PURPOSE AND SCOPE

1.1 Purpose

1.1.1 Contains methodologies for and parameters necessary for calculating offsite doses, determination of gaseous and liquid radiation monitor set points, and administrative controls for effluent instrumentation, Radiological Effluent Tech Specs (RETS), and the Radiological Environmental Monitoring Program (REMP).

1.2 Scope

1.2.1 Radioactive effluents are generated from station activities. These controls provide methodologies ensuring these effluents are properly monitored and quantified to promote accurate dose reporting. Additional controls ensure station equipment and processes are used to minimize release to the environment. The combination of minimizing release, accurately reporting dose, and monitoring the facility environs provides the basis for ensuring that station activities are not negatively impacting public health and the environment.

2.0 DEFINITIONS

2.1 Abnormal Discharge - The unplanned or uncontrolled emission of an effluent (i.e., containing facility-related, licensed radioactive material) into the unrestricted area.

2.2 Abnormal Release - The unplanned or uncontrolled emission of an effluent (i.e., containing facility-related, licensed radioactive material).

2.3 Channel Check - A CHANNEL CHECK shall be the qualitative assessment of channel behavior during operation by observation. This determination shall include, where possible, comparison of the channel indication and/or status with other indications and/or status derived from independent instrument channels measuring the same parameter.

2.4 Channel Function Test - Injection of a simulated signal into the channel to verify that it is functional, including any alarm and/or trip initiating action.

2.5 Effluent Concentration Limit (ECL) - Radionuclide limits listed in 10 CFR Part 20, Appendix B, Table 2, Column 1.

2.6 Member(s) of the Public - Member(s) of the Public means any individual except when that individual is receiving occupational dose.

- 2.7 Functional-Functionality - A system, subsystem, train, component or device shall be FUNCTIONAL or have FUNCTIONALITY when it is capable of performing its specified function(s) and when all necessary attendant instrumentation, controls, normal or emergency electrical power sources, cooling and seal water, lubrication, and other auxiliary equipment that are required for the system, subsystem, train, component, or device to perform its function(s) are also capable of performing their related support function(s).
- 2.8 Residual Radioactivity - Residual radioactivity means radioactivity in structures, materials, soils, ground water, and other media at a site resulting from activities under the licensee's control. This includes radioactivity from all licensed and unlicensed sources used by the licensee, but it excludes background radiation. It also includes radioactive materials remaining at the site as a result of routine or accidental releases of radioactive material at the site and previous burials at the site, even if those burials were made in accordance with the provisions of 10 CFR Part 20.
- 2.9 Site Boundary - The Site Boundary is the line beyond which the land is neither owned, or leased, nor controlled by the licensee.
- 2.10 Source Check - A SOURCE CHECK shall be the qualitative assessment of channel response when the channel sensor is exposed to a source of increased radioactivity.
- 2.11 Special Liquid - Non-routine release pathway in which normally non-radioactive liquid streams (such as Raw Water) found to contain radioactive material, are non-routine, and will be treated on a case specific basis if and when this occurs.
- 2.12 Unrestricted Area - An UNRESTRICTED AREA shall be any area at or beyond the SITE BOUNDARY access to which is not controlled by the licensee for purposes of protection of individuals from exposure to radiation and radioactive materials, or any area within the SITE BOUNDARY used for residential quarters or for industrial, commercial, institutional, and/or recreational purposes.
- 2.13 Venting - VENTING shall be the controlled process of discharging air or gas from a confinement to maintain temperature, pressure, humidity, concentration, or other operating condition, in such a manner that replacement air or gas is not provided or required during VENTING. Vent, used in system names, does not imply a VENTING process.
- 2.14 Water Effluent Concentration (WEC) - Radionuclide limits listed in 10 CFR Part 20, Appendix B, Table 2, Column 2.

Table 1.2 - Frequency Notation

The surveillance intervals are defined as follows:

Notation	Title	Frequency^A
S	Shift	At least once per 12 hours
D	Daily	At least once per 24 hours
W	Weekly	At least once per 7 days
BW	Biweekly	At least once per 14 days
M	Monthly	At least once per 31 days
Q	Quarterly	At least once per 92 days
SA	Semiannual	At least once per 184 days
A	Annually	At least once per 366 days
R		At least once per 18 months
P	Prior to	Prior to each release (Performance within 24 hrs.)

- A. Each surveillance requirement shall be performed within the specified surveillance interval with a maximum allowable extension not to exceed 25 percent of the specified surveillance interval.

Table 1.3 - Radiological Effluent Controls Program Implementation

NO-FC-10 Appendix E	ODCM Implementing Step
E.2.1.3.a	3.1.1, 3.2.1
E.2.1.3.b	4.1.1
E.2.1.3.c	Table 4.1, Table 4.2
E.2.1.3.d	4.1.2
E.2.1.3.e	4.1.2B.1, 4.2.2B.1
E.2.1.3.f	4.1.3A, 4.2.4A
E.2.1.3.g	4.2.2
E.2.1.3.h	4.2.3
E.2.1.3.i	4.3.1
E.3.1.3.a	5.1.1
E.3.1.3.b	5.2.1
E.3.1.3.c	5.3.1
E.1.2	6.3, 6.2.1D
E.4.1	6.2.1
E.4.2	6.2.2

3.0 INSTRUMENTATION

3.1 Radioactive Liquid Effluent Instrumentation

3.1.1 Limiting Condition for Operation

- A. The radioactive liquid effluent monitoring instrumentation channels shown in Table 3.1.1 shall be FUNCTIONAL with their alarm/trip setpoints set to ensure that the limits of Specification 3.1.1 are not exceeded. The alarm/trip setpoints of these channels shall be determined in accordance with Part II of the Off-Site Dose Calculation Manual.

APPLICABILITY: At all times

ACTION:

1. With a radioactive liquid effluent monitoring instrumentation channel alarm/trip setpoint less conservative than required by the above specification, immediately suspend the releases of radioactive liquid effluents monitored by the affected channel or declare the channel non-functional.
2. With less than the minimum number of radioactive liquid effluent monitoring instrumentation channels functional, take the action shown in Table 3.1.1. Restore non-functional effluent monitoring instrumentation to FUNCTIONAL status within 30 days and, if unsuccessful, explain in the next Annual Radiological Effluent Release Report why this non-functionality was not corrected in a timely manner. The reporting requirement is limited to the following instrumentation that monitors effluent stream: RM-055.

3.1.2 Surveillance Requirements

- A. Each radioactive liquid effluent monitoring instrumentation channel shall be demonstrated FUNCTIONAL by performance of the CHANNEL CHECK, SOURCE CHECK, CALIBRATION, and CHANNEL FUNCTIONAL TEST at the frequencies shown in Table 3.1.2.

Table 3.1.1 - Radioactive Liquid Effluent Monitoring Instrumentation

Instrument		Minimum Channels Functional	Action
1.	Radioactivity Monitor Providing Alarm and Automatic Termination of Release.		
1.1	Liquid Radwaste Effluent Line (RM-055)	1	1, 4
2.	Flow Rate Measurement Device		
2.1	Liquid Radwaste Effluent Line	1	2
3.	Radioactivity Recorder		
3.1	Liquid Radwaste Effluent Line	1	3

Table Notation

ACTION 1	With the number of channels FUNCTIONAL less than required by the Minimum Channels FUNCTIONAL requirement, effluent releases may continue provided that prior to initiating a release: <ol style="list-style-type: none"> At least two independent samples are analyzed in accordance with applicable chemistry procedures. At least two qualified individuals independently verify the release rate calculations.
ACTION 2	With the number of channels FUNCTIONAL less than required by the Minimum Channels FUNCTIONAL requirement, effluent releases may continue provided the flow rate is determined at least once per four hours during the actual release.
ACTION 3	With the number of channels FUNCTIONAL less than required by the Minimum Channels FUNCTIONAL requirement, effluent releases may continue provided the radioactivity is recorded manually at least once per four hours during the actual release.
ACTION 4	During the performance of source checks the effluent radiation monitor is unable to respond, hence is considered non-functional. Effluent releases may continue uninterrupted during the performance of source checks provided the operator is stationed at the monitor during the check. If the effluent radiation monitor fails the source check, carryout the action(s) of the Off-Site Dose Calculation Manual for the non-functional monitor or terminate the effluent release.

Table 3.1.2 - Radioactive Liquid Effluent Monitoring Instrumentation Surveillance Requirements

Instrument	Channel Check	Channel		Source Check
		Calibration	Function Test	
1. Radioactivity Monitor Providing Alarm and Automatic Isolation				
1.1 RM-055	----	R	Q	P

3.2 Radioactive Gaseous Effluent Instrumentation

3.2.1 Limiting Condition for Operation

- A. The radioactive gaseous effluent monitoring instrumentation channels shown in Table 3.2.1 shall be FUNCTIONAL to ensure that the limits of Specification 3.2.1 are not exceeded.

APPLICABILITY: At all times

ACTION:

1. With less than the minimum number of radioactive gaseous effluent monitoring instrumentation channels functional, take the action shown in Table 3.2.1. Restore non-functional effluent monitoring instrumentation to FUNCTIONAL status within 30 days and, if unsuccessful, explain in the next Annual Radiological Effluent Release Report why this non-functionality was not corrected in a timely manner. The reporting requirement is limited to the following instrumentation that monitors effluent streams: RM-043, RM-062, RM-052 and Particulate Air Samplers.

3.2.2 Surveillance Requirements

- A. Each radioactive gaseous effluent monitoring instrumentation channel shall be demonstrated FUNCTIONAL by performance of the CHANNEL CHECK, CALIBRATION, and CHANNEL FUNCTIONAL TEST at the frequencies shown in Table 3.2.2.

Table 3.2.1 - Radioactive Gaseous Effluent Monitoring Instrumentation

Instrument		Minimum Channels Functional	Action
1.	Forced Draft releases		
1.1	Particulate-Auxiliary Bldg. Exhaust Stack (RM-052, RM-062)	1	1,4
1.2	Particulate-Laboratory and Radwaste Processing Building Stack (RM-043)	1	2
1.3	Particulate air sampler-Portable filtered ventilation systems discharge	1	5
2.	Unventilated building opening		
2.1	Particulate air sampler-open doorway/ open rollup door	1	6
3.	Open-air demolition		
3.1	Particulate air samplers (4 air samplers at each open-air location)	4	7
4.	Flow Rate Measurement Devices		
4.1	Auxiliary Building Exhaust Stack	1	3
4.2	Laboratory and Radwaste Processing Building Stack	1	3
4.3	Hand-held anemometer	1	3

Table 3.2.1 Radioactive Gaseous Effluent Monitoring Instrumentation

Table Notation	
ACTION 1	If the Auxiliary Building Exhaust Stack Particulate Sampler is non-functional, ventilation of the Auxiliary Building may continue through the Auxiliary Building Exhaust Stack provided sample collection in accordance with Table 4.2 using auxiliary sample collection equipment is initiated within 2 hours of the declaration of non-functionality by the ISFSI Shift Supervisor (ISS).
ACTION 2	If the Particulate Sampler is non-functional, ventilation of the LRWPB may continue via the LRWPB Stack provided sample collection using auxiliary sample collection equipment is initiated within 2 hours of the declaration of non-functionality, by the ISFSI Shift Supervisor (ISS), in accordance with Table 4.2.
ACTION 3	With the number of channels FUNCTIONAL less than required by the Minimum Channels FUNCTIONAL requirement, effluent releases may continue provided the flowrate is estimated or recorded manually at least once per four hours during the actual release.
ACTION 4	During the ventilation of airborne effluents from the Auxiliary Building Exhaust Stack at least one Auxiliary Building Exhaust fan shall be in operation.
ACTION 5	If portable air sampler monitoring the discharged of a portable filtered ventilation unit OR its associated flowmeter is non-functional, active decommissioning may continue provided the portable air sampler is replaced within 2 hours of declaration of non-functionality. If air sampler is unable to be replaced within 2 hours, secure the release fan AND cease active decommissioning in the area monitored by the non-functioning air sampler.
ACTION 6	If portable air sampler monitoring open doorways in unventilated building flowpaths OR its associated flowmeter is non-functional, active decommissioning may continue provided the portable air sampler is replaced within 2 hours of declaration of non-functionality. If air sampler is unable to be replaced within 2 hours, close the door associated with this air sampler OR cease active decommissioning work until the air sampler can be replaced.
ACTION 7	If any of the 4 air samplers monitoring air around an open-air demolition location OR their associated flowmeters are non-functional, active decommissioning may continue provided the portable air sampler is replaced within 2 hours of declaration of non-functionality. If the open-air demolition location is unable to be monitored by 4 air samplers, cease active open-air decommissioning at the affected location.

Table 3.2.2 - Radioactive Gaseous Effluent Monitoring Instrumentation
Surveillance Requirements

Instrument		Channel Check	Calibration	Channel Function Test	Source Check
1.	Flowrate Monitors				
1.1	RM-043 Sampler	D	R	Q	----
1.2	RM-062 Sampler	D	R	Q	----
1.3	RM-052 Sampler	D	R	Q	----
1.4	Auxiliary Bldg Exhaust Stack	D	R	Q	----
1.5	Laboratory and Radwaste Process Bldg Exhaust Stack	D	R	Q	----
		Operations Check		Air Flow Calibration	
2.	Environmental Monitors				
2.1	RM-023 - Sample Station #40		M		A
2.2	RM-024 - Sample Station #41		M		A
2.3	RM-025 - Sample Station #28		----		----
2.4	RM-026 - Sample Station #36		----		----
2.5	RM-027 - Sample Station #37		M		A
2.6	RM-028 - Sample Station #38		----		----
2.7	RM-029 - Sample Station #39		----		----
2.8	RM-035 - Sample Station #1		----		----
2.9	RM-036 - Sample Station #2		M		A
2.10	RM-037 - Sample Station #3		----		----
2.11	RM-038 - Sample Station #4		M		A
2.12	RM-039 - Sample Station #5		----		----
2.13	RM-040 - Sample Station #32		M		A
3.	Decommissioning portable air sampler flowmeters				
3.1	All sample stations		W ¹		A

1- Operation check performed only when the unit is started to support active decommissioning.

4.0 **RADIOACTIVE EFFLUENTS**

4.1 Radioactive Liquid Effluents

4.1.1 Concentration

A. Limiting Condition for Operation

1. The release rate of radioactive material in liquid effluents shall be controlled such that the instantaneous concentrations for radionuclides do not exceed the values specified in 10 CFR Part 20 for liquid effluents at site discharge. To support facility operations, RP/Chemistry supervision may increase this limit up to the limit specified in QATR Appendix E, E.2.1.3.b.
2. QATR Appendix E, E.2.1.3.b establishes the administrative control limit on concentration of radioactive material, other than dissolved or entrained noble gases, released in liquid effluents to unrestricted areas conforming to ten times 10 CFR Part 20.1001-20.2401, Appendix B, Table 2, Column 2.

APPLICABILITY: At all times

ACTION:

- a. When the concentration of radioactive material released at site discharge exceeds the above limits, appropriate corrective actions shall be taken immediately to restore concentrations within the above limits.

B. Surveillance Requirements

i	<u>NOTE</u>	i
	Radioactive liquid waste includes water used for fire suppression in areas of the facility that may contain radioactivity. These liquids are required to be monitored prior to release.	

1. Radioactive liquid waste shall be sampled and analyzed according to the sampling and analysis program in Table 4.1.
2. The results of the radioactivity analysis shall be used with the calculational methods in Part II of the Off-Site Dose Calculation Manual.
3. To assure that the concentration at the point of release is maintained within the limits of QATR Appendix E, E.2.1.3.b.
4. Records shall be maintained of the radioactive concentrations and volume before dilution of each batch of liquid effluent released and of the average dilution flow and length of time over which each discharge occurred. Analytical results shall be submitted to the Commission in accordance with Part I, Section 6.0 of the Off-Site Dose Calculation Manual.

Table 4.1 - Radioactive Liquid Effluent Sampling and Analysis

A. Monitor, Hotel Waste Tanks & Special Liquid, Releases

Sampling Frequency	Type of Activity Analysis	Lower Limit of Detection (LLD) ($\mu\text{Ci/ml}$) ^A
Each Batch	Principal Gamma Emitters ^B	5.0E-07
Monthly Composite ^C	H-3	1.0E-05
Monthly Composite ^C	Gross Alpha	1.0E-07
Quarterly Composite ^C	Sr-89, Sr-90	5.0E-08
Quarterly Composite ^C	Fe-55, Ni-63	1.0E-06

NOTES:

- A. LLD is defined in Part II of the Off-Site Dose Calculation Manual.
- B. The principal gamma emitters for which the LLD specification applies exclusively are the following radionuclides: Mn-54, Fe-59, Co-58, Co-60, Zn-65, Mo-99, Cs-134, Cs-137, and Ce-141 for fission and corrosion products. Ce-144 shall also be measured, but with a LLD of 5.0E-06.
- C. To be representative of the average quantities and concentrations of radioactive materials in liquid effluents, samples should be collected in proportion to the rate of flow of the effluent stream. Prior to analyses, all samples taken for the composite should be mixed in order for the composite sample to be representative of the average effluent release.

4.1.2 Dose from Radioactive Liquid Effluents

A. Limiting Condition for Operation

1. The dose or dose commitment to an individual in unrestricted areas from radioactive materials in liquid effluents shall be limited to the following:
 - a. During any calendar quarter: Less than or equal to 1.5 mrem to the total body and 5 mrem to any organ; and
 - b. During any calendar year: Less than or equal to 3 mrem to the total body and 10 mrem to any organ.

APPLICABILITY: At all times

ACTION:

- a. If the dose contribution, due to the cumulative release of radioactive materials in liquid effluents, exceeds the annual or quarterly dose objectives, submit a Special Report to the NRC, per Section 6.2.4, within 30 days.

B. Surveillance Requirements

1. Cumulative dose contributions from liquid effluents for the current calendar quarter and the current calendar year shall be determined in accordance with the methodology and parameters in Part II of the Off-Site Dose Calculation Manual at least once per quarter.

4.1.3 Liquid Radwaste Treatment

A. Limiting Condition for Operation

1. The Liquid Radwaste Treatment System shall be FUNCTIONAL, and appropriate portions of these systems shall be used to reduce releases of radioactivity when the projected doses due to the liquid effluent, from each unit, to UNRESTRICTED AREAS would exceed 0.06 mrem to the whole body or 0.2 mrem to any organ in a 31-day period.

APPLICABILITY: At all times

ACTION:

- a. With radioactive liquid waste being discharged without treatment and in excess of the above limits and any portion of the Liquid Radwaste Treatment System not in operation, prepare and submit to the Nuclear Regulatory Commission within 30 days, pursuant to 10 CFR 50, Appendix I, a Special Report that includes the following information:
 - 1) Explanation of why liquid radwaste was being discharged without treatment, identification of equipment or subsystem(s) not functional and reasons for non-functionality.
 - 2) Action(s) taken to restore the non-functional equipment to functional status.
 - 3) Summary description of action(s) taken to prevent a recurrence.

B. Surveillance Requirements

1. Dose due to liquid releases shall be projected frequently and at least once per quarter, in accordance with the methodology and parameters in Part II of the Off-Site Dose Calculation Manual, when Liquid Radwaste Treatment Systems are not fully FUNCTIONAL.
2. FUNCTIONAL is defined as follows:
 - a. A filtration/ion exchange (FIX) system will be utilized for processing liquid radwaste. The system consists of a booster pump, charcoal pretreatment filter, and pressure vessels containing organic/inorganic resins, which can be configured for optimum performance. The effluent from the FIX system is directed to the monitor tanks for release.

4.1.3B.2 (continued)

- b. Waste filters (WD-17A and WD-17B) are used only on those occasions when considered necessary, otherwise the flows from the low activity fluids may bypass the filters. No credit for decontamination factors (iodines, Cs, Rb, others) was taken for these filters during the 10 CFR Part 50 Appendix I dose design objective evaluation; therefore, the non-functionality of these filters does not affect the dose contributions to any individual in the unrestricted areas via liquid pathways. The non-functionality of waste filters will not be considered a reportable event in accordance with the Action listed above.

4.1.4 Liquid Holdup Tanks

Tanks included in this Specification are those outdoor tanks that are not surrounded by liners, dikes, or walls capable of holding the tanks contents and that do not have tank overflows and surrounding area drains connected to the liquid radwaste treatment system.

A. Limiting Condition for Operation

1. The quantity of radioactive material contained in each unprotected outdoor liquid holdup tank shall not exceed 10 curies, excluding tritium and dissolved or entrained noble gases.

APPLICABILITY: At all times

ACTION:

- a. When the quantity of radioactive material in any unprotected outdoor liquid holdup tank exceeds 10 curies, excluding tritium and dissolved or entrained noble gasses, immediately suspend all additions of radioactive material to the tank and within 48 hours reduce the tank contents to within the limit.

B. Surveillance Requirements

1. The quantity of radioactive material contained in each outdoor liquid holdup tank shall be determined to be within the above limit by analyzing a representative sample of the tanks contents at least once per 7 days when radioactive material is being added to the tank.

4.2 Radioactive Gaseous Effluents

4.2.1 Concentration

A. Limiting Condition for Operation

1. The release rate of radioactive material in airborne effluents shall be controlled such that the instantaneous concentrations of radionuclides does not exceed the values specified in 10 CFR Part 20 for airborne effluents at the unrestricted area boundary.

APPLICABILITY: At all times

ACTION:

- a. When the concentration of radioactive material released to unrestricted areas exceeds the above limits, appropriate corrective actions shall be taken immediately to restore concentrations within the above limits.

B. Surveillance Requirements

i	<u>NOTE</u>	i
	Radioactive gaseous wastes include atmospheres in areas where gaseous fire suppression systems are utilized or where smoke is produced as a result of fire in areas of the facility that may contain radioactivity. These atmospheres are required to be monitored prior to gaseous release to unrestricted areas.	

1. Radioactive gaseous wastes shall be sampled and analyzed according to the sampling and analysis program of Table 4.2. The results of the radioactivity analysis shall be used to assure the limits in Step 4.2.1A are not exceeded.

Table 4.2 - Radioactive Airborne Effluent Sampling and Analysis

A. Auxiliary Building Exhaust Stack ^D

Sampling Frequency	Type of Activity Analysis	Lower Limit of Detection (LLD) ($\mu\text{Ci/ml}$) ^A
Weekly (Particulate Sample)	Principal Gamma Emitters ^B	1.0E-11
Weekly	Tritium (H-3)	1.0E-06
Monthly Composite ^C	Gross Alpha	1.0E-11
Quarterly Composite (Particulate Samples)	Sr-89, Sr-90	1.0E-11

B. Laboratory and Radwaste Building Exhaust Stack ^D

Sampling Frequency	Type of Activity Analysis	Lower Limit of Detection (LLD) ($\mu\text{Ci/ml}$) ^A
Weekly (Particulate Sample)	Principal Gamma Emitters ^B	1.0E-11
Monthly Composite ^C	Gross Alpha	1.0E-11
Quarterly Composite (Particulate Sample)	Sr-89, Sr-90	1.0E-11

C. Forced Draft Exhaust discharge

Sampling Frequency	Type of Activity Analysis	Lower Limit of Detection (LLD) ($\mu\text{Ci/ml}$) ^A
Weekly (Particulate Sample)	Principal Gamma Emitters ^B	1.0E-11
Monthly Composite ^C	Gross Alpha	1.0E-11
Quarterly Composite (Particulate Sample)	Sr-90	1.0E-11

D. Unventilated building doorways

Sampling Frequency	Type of Activity Analysis	Lower Limit of Detection (LLD) ($\mu\text{Ci/ml}$) ^A
Weekly (Particulate Sample)	Principal Gamma Emitters ^B	1.0E-11
Monthly Composite ^C	Gross Alpha	1.0E-11
Quarterly Composite (Particulate Sample)	Sr-90	1.0E-11

E. Open-Air Demolition locations

Sampling Frequency	Type of Activity Analysis	Lower Limit of Detection (LLD) ($\mu\text{Ci/ml}$)^A
Weekly (Particulate Sample)	Principal Gamma Emitters ^B	1.0E-11
Monthly Composite ^C	Gross Alpha	1.0E-11
Quarterly Composite (Particulate Sample)	Sr-90	1.0E-11

NOTES:

- A. LLD is defined in Part II of the Off-Site Dose Calculation Manual.
- B. The principal gamma emitters for which the LLD specification applies exclusively are the following radionuclides: Mn-54, Fe-59, Co-58, Co-60, Zn-65, Mo-99, Cs-134, Cs-137, Ce-141, and Ce-144 for particulate releases.
- C. Frequency requirement may be satisfied using weekly gross alpha results from particulate sampling media.
- D. Particulate samples shall be corrected for sampler deposition/transportation efficiency by using the approved software programs or by multiplying the activity obtained by the associated sampler multiplication factor (See Table 4.3).

Table 4.3 - Sampler Deposition/Transportation Correction Factors

Sampler	Sample	Particulate	
		DF	ACTMULT
RM-062	AB	0.411	2.433
RM-052	AB	0.638	1.567
RM-043	LRWPB	0.809	1.236
Portable Air Sampler	Forced Draft, Unventilated Building, Open-Air	1.00	1.00

ACRONYM DEFINITIONS:

AB - Auxiliary Building Exhaust Stack

LRWPB - Laboratory and Rad Waste Processing Building

DF - Deposition Factor

ACTMULT - Activity multiplication factor to correct for sample loss.

4.2.2 Dose - H-3 and Radioactive Material in Particulate Form with Half-Lives Greater than 8 Days (Other than Noble Gases)

A. Limiting Condition for Operation

1. The dose to an individual or dose commitment to any organ of an individual in unrestricted areas due to the release of H-3 and radioactive materials in particulate form with half-lives greater than eight days (excluding noble gases) in airborne effluents shall be limited to the following:
 - a. During any calendar quarter: Less than or equal to 7.5 mrem to any organ; and
 - b. During any calendar year: Less than or equal to 15 mrem to any organ.

APPLICABILITY: At all times

ACTION:

- a. If the dose contribution, due to the cumulative release of H-3 and radioactive materials in particulate form with half-lives greater than eight days, exceeds the annual or quarterly dose objectives, submit a Special Report to the NRC per Section 6.2.4, within 30 days.

B. Surveillance Requirements

1. The radiation dose contributions from H-3 and radioactive materials in particulate form with half-lives greater than eight days (excluding noble gases) in airborne effluents shall be determined, in accordance with the methodologies and parameters of Part II of the Off-Site Dose Calculation Manual, on a quarterly basis.

4.2.3 Gaseous Radwaste Treatment

A. Limiting Condition for Operation

1. In accordance with QATR Appendix E, E.2.1.3.f, the Ventilation Exhaust Systems shall be FUNCTIONAL, and appropriate portions of these systems shall be used to reduce the releases of radioactivity when the projected doses in 31 days due to gaseous effluent releases to areas at and beyond the SITE BOUNDARY would exceed:
 - a. 0.2 mrad to air from gamma radiation, or

- b. 0.4 mrad to air from beta radiation, or
- c. 0.3 mrem to any organ of a MEMBER OF THE PUBLIC

APPLICABILITY: At all times

ACTION:

- a. With radioactive gaseous waste being discharged without treatment and in excess of the above limits, prepare and submit a report to the Nuclear Regulatory Commission within 30 days, pursuant to 10 CFR 50, Appendix I, a special report that includes the following information:
 - 1) Identification of equipment or subsystem(s) not functional and reasons for non-functionality.
 - 2) Action(s) taken to restore the non-functional equipment to functional status.
 - 3) Summary description of action(s) taken to prevent a recurrence.

B. Surveillance Requirements

- 1. Dose due to gaseous releases shall be projected frequently and at least once per quarter, in accordance with the methodology and parameters in Part II of the Off-Site Dose Calculation Manual, when Ventilation Exhaust Systems are not fully FUNCTIONAL.
- 2. FUNCTIONAL is defined as follows:
 - a. Ventilation Exhaust Systems
 - 1) The radioactive effluents from the controlled access area of the auxiliary building are filtered by the HEPA filters in the auxiliary building ventilation system. If the radioactive effluents are discharged without the HEPA filters and it is confirmed that one half of the annual dose objective will be exceeded during the calendar quarter, a special report shall be submitted to the Commission pursuant to Section 4.2.3A.

4.3 Uranium Fuel Cycle

4.3.1 Total Dose-Uranium Fuel Cycle

A. Limiting Condition for Operation

1. The dose to any real individual from uranium fuel cycle sources shall be limited to ≤ 25 mrem to the total body or any organ (except the thyroid, which shall be limited to ≤ 75 mrem) during each calendar year.

APPLICABILITY: At all times

ACTION:

- a. With the calculated dose from the release of radioactive materials in liquid or gaseous effluents exceeding twice the limits of specifications 4.1.2A, or 4.2.2A, calculations shall be made including direct radiation contribution from the facility and outside storage tanks to determine whether the above limits have been exceeded. If such is the case, in lieu of any other report required by Section 6.2, prepare and submit a Special Report to the Commission pursuant to QATR Appendix E, E.2.1 that defines the corrective action to be taken to reduce subsequent releases to prevent recurrence of exceeding the above limits and includes the schedule for achieving conformance with the above limits. This Special Report, as defined in 10 CFR Part 20.2203(a)(4) and 20.2203(b), shall include an analysis that estimates the radiation exposure (dose) to a MEMBER OF THE PUBLIC from uranium fuel cycle sources, including all effluent pathways and direct radiation, for the calendar year that includes the release(s) covered by this report. It shall also describe levels of radiation and concentration of radioactive material involved, and the cause of exposure levels or concentrations. If the estimated dose(s) exceeds the above limits, and if the release condition resulting in the violation of 40 CFR Part 190 or 10 CFR Part 72.104 has not already been corrected, the Special Report shall include a request for a variance in accordance with the provisions of 40 CFR Part 190 or 10 CFR Part 72.104. Submittal of the report is considered a timely request, and a variance is granted until staff action on the request is complete.

4.3.1 (continued)

B. Surveillance Requirements

1. Cumulative dose contributions from liquid and gaseous effluents shall be determined in accordance with surveillance requirements 4.1.2B and 4.2.2B and in accordance with the methodology and parameters in Part II of the Off-Site Dose Calculation Manual.

5.0 RADIOLOGICAL ENVIRONMENTAL MONITORING PROGRAM (REMP)

5.1 Monitoring Program

5.1.1 Limiting Condition for Operation

- A. The Radiological Environmental Monitoring Program shall be conducted as specified in Table 5.1.

APPLICABILITY: At all times

ACTION:

1. Analytical results of this program and deviations from the sampling schedule shall be reported to the Nuclear Regulatory Commission in the Annual Radiological Environmental Operating Report (Section 6.2).
2. If the level of radioactivity from calculated doses leads to a higher exposure pathway to individuals, this pathway shall be added to the Radiological Environmental Monitoring Program. Modifications to the program shall be reported in the Annual Radiological Environmental Operating Report to the Nuclear Regulatory Commission.
3. If the level of radioactivity in an environmental sampling medium exceeds the reporting level specified in Table 5.4, and the activity is attributable to facility operation, a Special Report shall be prepared and submitted to the Nuclear Regulatory Commission within 30 days (Section 6.2.4). The detection capabilities of the equipment used for the analysis of environmental samples must meet the requirements of Table 5.3 for Lower Level of Detection (LLD).

5.1.1A (continued)

4. If the level of radioactivity in a sample from either an onsite or offsite well, performed per the Site Groundwater Protection Program, exceeds the reporting level specified in Table 5.4, and the activity is attributable to facility operation, a Special Report shall be prepared and submitted to the Nuclear Regulatory Commission within 30 days (Section 6.2.4). The detection capabilities of the equipment used for the analysis of environmental samples must meet the requirements of Table 5.3 for Lower Level of Detection (LLD). Copies of the Special Report will be forwarded to State/Local authorities. **[AR 39127]**
5. If the level of radioactivity from either an onsite or offsite well, performed per the Site Groundwater Protection Program exceeds the reporting level specified in Table 5.4, and the activity is attributable to facility operations, state and local authorities shall be notified by the end of the next business day. NRC shall be notified per FCSI-RA-105, Reporting of Events and Conditions. **[AR 39127]**
6. Radiological environmental sampling locations and the media that is utilized for analysis are presented in Table 5.2. Sampling locations are also illustrated on the map, Figure 1. Details of the quarterly emergency TLD locations are contained in surveillance test CH-FT-RV-0003, Environmental Sample Collection – Quarterly/Environmental Dosimeters (TLDs). Each TLD sample location contains one dosimeter that is exchanged quarterly for REMP sampling and as needed for Emergency Planning Zone monitoring.
7. Deviations from the monitoring program, presented in this section and detailed in Table 5.2, are permitted if specimens are unobtainable due to mitigating circumstances such as hazardous conditions, seasonal unavailability, malfunction of equipment, or if a person discontinues participation in the program, etc. If the equipment malfunctions, corrective actions will be completed as soon as practicable. If a person no longer supplies samples, a replacement will be made if possible. All deviations from the sampling schedule will be described in the Annual Radiological Environmental Operating Report, pursuant to Section 6.2.

5.1.2 Surveillance Requirements

- A. The Radiological Environmental Monitoring Program (REMP) samples shall be collected and analyzed in accordance with Tables 5.1, 5.2, and 5.3.

Table 5.1 - Radiological Environmental Monitoring Program

Exposure Pathway and/or Sample	Collection Site ^A	Type of Analysis ^B	Frequency
1. Direct Radiation	A. 14 TLD indicator stations.	Gamma dose	Quarterly
	B. An inner-ring of 16 stations, one in each cardinal sector in the general area of the unrestricted area boundary and within 2.5 miles.	Gamma dose	Quarterly
	C. An outer-ring of 16 background stations, one in each cardinal sector located outside of the inner-ring, but not closer than approximately 2.5 miles and one additional remote background station for a total of 17. ^F	Gamma dose	Quarterly
	D. Other TLDs may be placed at special interest locations beyond the Restricted Area where either a MEMBER OF THE PUBLIC or Omaha Public Power District employees have routine access.	Gamma dose	Quarterly
2. Air Monitoring	A. Indicator Stations 1. Three stations in the general area of the unrestricted area boundary 2. City of Blair 3. Desoto Township	Filter for Gross Beta ^C Filter for Gamma Isotopic	Weekly Quarterly composite of weekly filters
	B. One background station ^F		
3. Water	A. Missouri River at nearest downstream drinking water intake.	Gamma Isotopic, H-3	Monthly for Gamma isotopic analysis.
	B. Missouri River downstream near the mixing zone.		Quarterly composite for H-3 Analysis
	C. Missouri River upstream of Facility intake (background) ^F .		
4. Milk ^D	A. Nearest milk animal (cow or goat) within 5 miles	Gamma Isotopic	Monthly
	B. Milk animal (cow or goat) between 5 miles and 18.75 miles (background) ^F .		

Table 5.1 - Radiological Environmental Monitoring Program

Exposure Pathway and/or Sample	Collection Site ^A	Type of Analysis ^B	Frequency
5. Fish	A. Four fish samples within vicinity of Facility discharge. B. One background sample upstream of Facility discharge.	Gamma Isotopic	Once per season (May to October)
6. Vegetables or Food Products ^E	A. One sample in the highest exposure pathway. B. One sample from onsite crop field C. One sample outside of 5 miles (background) ^F .	Gamma Isotopic	Once per season (May to October)
7. Groundwater	A. Three samples from sources potentially affected by facility operations. B. One sample outside of 5 miles (background) ^F .	H ₃ , Gross Beta, Gamma Isotopic, Sr-90	Quarterly
8. Vegetation in lieu of milk	A. One sample at the highest annual average D/Q offsite location. B. One sample at the second highest annual average D/Q offsite location. C. One sample outside of 5 miles (background) ^F .	Gamma Isotopic	Monthly (when available)

NOTES:

- A. See Table 5.3 for required detection limits.
- B. The Lower Limit of Detection (LLD) for analysis is defined in the Off-Site Dose Calculation Manual in accordance with the wording of NUREG-1301.
- C. When a gross beta count indicates radioactivity greater than $2.5E-13$ $\mu\text{Ci/ml}$ or 0.25 pCi/m^3 , (ten times the yearly mean), a gamma spectral analysis will be performed.
- D. If milk samples are temporarily not available at a sampling site due to mitigating circumstances, then vegetation (broadleaf, pasture grass, etc.) shall be collected as an alternate sample at the site. If there are no milk producers within the entire 5-mile radius of the facility, then vegetation shall be collected monthly, when available, at two offsite locations having the highest calculated annual average ground level D/Q and a background locale. (Reference Off-Site Dose Calculation Manual, Part II, Table 4 "Highest Potential Exposure Pathways for Estimating Dose")
- E. Samples should be collected from garden plots of 500 ft^2 or more. (Reference Reg. Guide 4.8 "Environmental Technical Specifications for Nuclear Power Plants," Dec. 1975).
- F. This sample may not be located in the least prevalent wind direction. The Branch Technical Position paper, Table 1, subnote "d" says this regarding background information, or control locations. **"The purpose of this sample is to obtain background information. If it is not practical to establish control locations in accordance with the distance and wind direction criteria, other sites which provide valid background data may be substituted".**

Table 5.2 - Radiological Environmental Sampling Locations And Media

Sample Station No.	Approximate Collection Sites	Approximate Distance from Center of Containment (miles)	Approximate Direction (degrees from true north)	Sector	Air Monitoring	TLD	Water	Milk	Sedi-ment	Fish	Vegetables and Food Products	Ground-water
					Airborne Particulate							
1	Onsite Station, 110-meter weather tower	0.53	293°/WNW	P		X						
2 ^{C,E}	Onsite Station, adjacent to old plant access road	0.59	207°/SSW	K	X	X						
3	Offsite Station, Intersection of Hwy. 75 and farm access road	0.94	145°/SE	G		X						
4	Blair OPPD office	2.86	305°/NW	Q	X	X						
5 ^A												
6	Fort Calhoun, NE City Hall	5.18	150°/SSE	H		X						
7	Fence around intake gate, Desoto Wildlife Refuge	2.07	102°/ESE	F		X						
8	Onsite Station, entrance to Plant Site from Hwy. 75	0.55	191°/S	J		X						
9	Onsite Station, NW of Plant	0.68	305°/NW	Q		X						
10	Onsite Station, WSW of Plant	0.61	242°/WSW	M		X						
11	Offsite Station, SE of Plant	1.07	39°/SE	G		X						

Table 5.2 - Radiological Environmental Sampling Locations And Media

Sample Station No.	Approximate Collection Sites	Approximate Distance from Center of Containment (miles)	Approximate Direction (degrees from true north)	Sector	Air Monitoring	TLD	Water	Milk	Sedi-ment	Fish	Vegetables and Food Products	Ground-water
					Airborne Particulate							
28 ^A												
29 ^A												
30 ^A												
31 ^A												
32 ^D	Valley Substation #902	19.6	221°/SW	L	X	X						
33 ^A												
34 ^A												
35	Onsite Farm Field	0.52	118°/ESE	F							X	
36	Offsite Station Intersection Hwy 75/Co. Rd. P37	0.75	227°/SW	L		X						
37	Offsite Station Desoto Township	1.57	144°/SE	G	X	X						
38 ^A												
39 ^A												
40 ^A												
41 ^{B,C}	Dowler Acreage	0.73	175°/S	J	X	X						
42	Sector A-1	1.94	0°/NORTH	A		X						
43	Sector B-1	1.97	16°/NNE	B		X						
44	Sector C-1	1.56	41°/NE	C		X						
45	Sector D-1	1.34	71°/ENE	D		X						
46	Sector E-1	1.54	90°/EAST	E		X						
47	Sector F-1	0.45	108°/ESE	F		X						

Table 5.2 - Radiological Environmental Sampling Locations And Media

Sample Station No.	Approximate Collection Sites	Approximate Distance from Center of Containment (miles)	Approximate Direction (degrees from true north)	Sector	Air Monitoring	TLD	Water	Milk	Sedi-ment	Fish	Vegetables and Food Products	Ground-water
					Airborne Particulate							
48	Sector G-1	1.99	134°/SE	G		X						
49	Sector H-1	1.04	159°/SSE	H		X						
50	Sector J-1	0.71	179°/SOUTH	J		X						
51	Sector K-1	0.61	205°/SSW	K		X						
52	Sector L-1	0.74	229°/SW	L		X						
53	Sector M-1	0.93	248°/WSW	M		X						
54	Sector N-1	1.31	266°/WEST	N		X						
55	Sector P-1	0.60	291°/WNW	P		X						
56	Sector Q-1	0.67	307°/NW	Q		X						
57	Sector R-1	2.32	328°/NNW	R		X						
58 ^D	Sector A-2	4.54	350°/NORTH	A		X						
59 ^D	Sector B-2	2.95	26°/NNE	B		X						
60 ^D	Sector C-2	3.32	50°/NE	C		X						
61 ^D	Sector D-2	3.11	75°/ENE	D		X						
62 ^D	Sector E-2	2.51	90°/EAST	E		X						
63 ^D	Sector F-2	2.91	110°/ESE	F		X						
64 ^D	Sector G-2	3.00	140°/SE	G		X						
65 ^D	Sector H-2	2.58	154°/SSE	H		X						
66 ^D	Sector J-2	3.53	181°/SOUTH	J		X						
67 ^D	Sector K-2	2.52	205°/SSW	K		X						
68 ^D	Sector L-2	2.77	214°/SW	L		X						
69 ^D	Sector M-2	2.86	243°/WSW	M		X						

Table 5.2 - Radiological Environmental Sampling Locations And Media

Sample Station No.	Approximate Collection Sites	Approximate Distance from Center of Containment (miles)	Approximate Direction (degrees from true north)	Sector	Air Monitoring	TLD	Water	Milk	Sedi-ment	Fish	Vegetables and Food Products	Ground-water
					Airborne Particulate							
70 ^D	Sector N-2	2.54	263°/WEST	N		X						
71 ^D	Sector P-2	2.99	299°/WNW	P		X						
72 ^D	Sector Q-2	3.37	311°/NW	Q		X						
73 ^D	Sector R-2	3.81	328°/NNW	R		X						
74	D. Miller Farm	0.65	203°/SSW	K								X
75 ^{B,C}	Lomp Acreage	0.65	163°/SSE	H	X	X					X	X
76 ^A												
77 ^G	River N-1	0.17	328°/NNW	R		X						
78 ^G	River S-1	0.14	85°/EAST	E		X						
79 ^G	Lagoon S-1	0.24	131°/SE	G		X						
80 ^G	Parking S-1	0.27	158°/SSE	H		X						
81 ^G	Training W-1	0.28	194°/SSW	K		X						
82 ^G	Switchyard S-1	0.21	219°/SW	L		X						
83 ^G	Switchyard SE-1	0.14	231°/SW	L		X						
84 ^G	Switchyard NE-1	0.18	256°/WSW	M		X						
85 ^G	Switchyard W-1	0.29	233°/WEST	L		X						
86 ^G	Switchyard N-1	0.24	262°/WEST	N		X						
87 ^G	Range S-1	0.20	286°/WNW	P		X						
88 ^G	Mausoleum E-1	0.37	216°/SW	L		X						
89	C, Miller	3.30	210°/SSW	K				X				

NOTES:

- A. Location is either not in use or currently discontinued and is documented in the table for reference only.
- B. If milk samples are temporarily not available at a sampling site due to mitigating circumstances, then vegetation (broadleaf, pasture grass, etc.) shall be collected as an alternate sample at the site. If there are no milk producers within the entire 5-mile radius of the facility, then vegetation shall be collected monthly, when available, at two offsite locations having the highest calculated annual average ground level D/Q and a background locale. (Reference Off-Site Dose Calculation Manual, Part II, Table 4 "Highest Potential Exposure Pathways for Estimating Dose")
- C. Locations represent highest potential exposure pathways as determined by the biennial Land Use Survey, performed in accordance with Part I, Section 7.3.2, of the Off-Site Dose Calculation Manual and are monitored as such.
- D. Background location (control). All other locations are indicators.
- E. Location for monitoring Sector K High Exposure Pathway Resident Receptor for inhalation.
- F. When broad leaf (pasture grasses) are being collected in lieu of milk, background broad leaf samples will be collected at a background locale.
- G. Location for special interest monitoring general dose to the public per 40CFR190 (Figure 2)

Figure 1 – Environmental Radiological Sampling Points

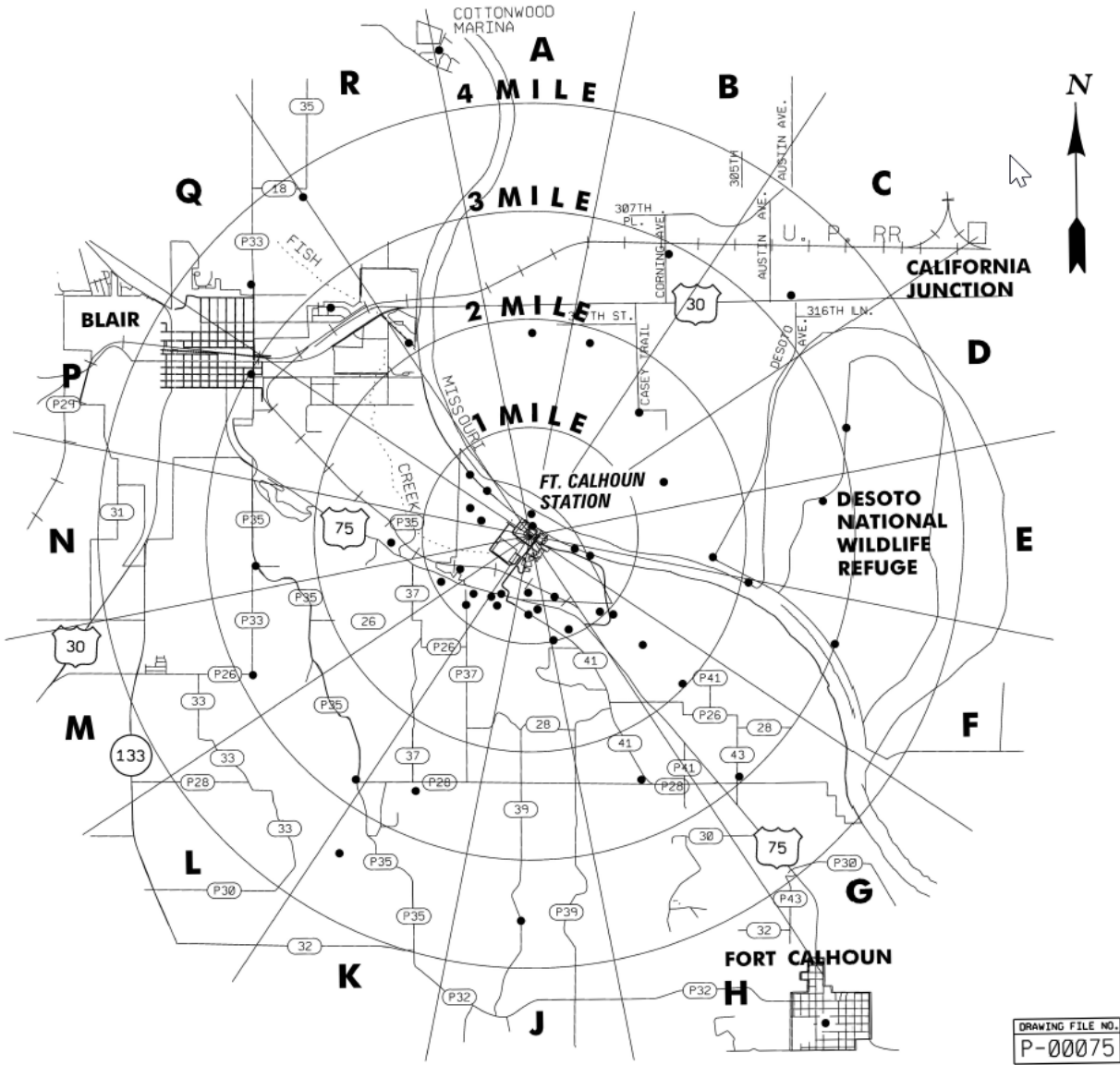

Figure 2- 40CFR190 Sampling Points

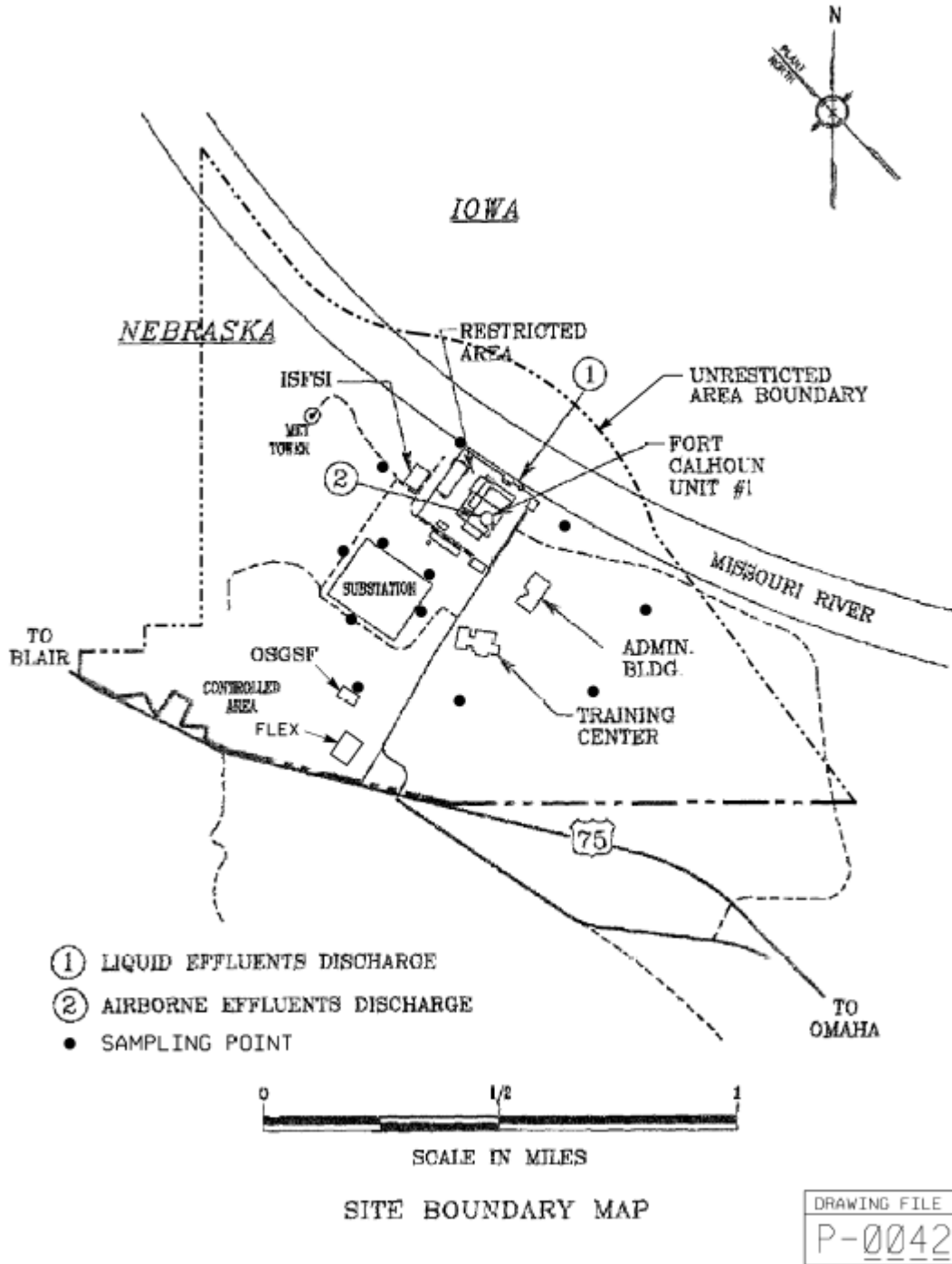

Table 5.3 - Detection Capabilities for Environmental Sample Analysis Lower Limit of Detection (LLD) ^{A, B, C}

Sample	Units	Gross Beta	H-3	Mn-54	Fe-59	Co-58, Co-60	Zn-65	Zr-95	Nb-95	Cs-134	Cs-137	Ba-140 La-140
Water	pCi/L	4	2.0E+03	1.5E+01	3.0E+01	1.5E+01	3.0E+01	1.5E+01	1.5E+01	1.5E+01	1.8E+01	1.5E+01
Fish	pCi/kg (wet)	---	---	1.3E+02	2.6E+02	1.3E+02	2.6E+02	---	---	1.3E+02	1.5E+02	---
Milk	pCi/L	---	---	---	---	---	---	---	---	1.5E+01	1.8E+01	1.5E+01
Airborne Particulates	pCi/m ³	1.0E-02	---	---	---	---	---	---	---	1.0E-02	1.0E-02	---
Sediment	pCi/kg (dry)	---	---	---	---	---	---	---	---	1.5E+02	1.8E+02	---
Grass or Broad Leaf Vegetation/ Vegetables or Food Products	pCi/kg (wet)	---	---	---	---	---	---	---	---	6.0E+01	8.0E+01	---

- A. This list does not mean that only these nuclides are to be considered. Other peaks that are identifiable as Facility effluents, together with those of the above nuclides, shall also be analyzed and reported in the Annual Radiological Environmental Operating Report pursuant to Part I, Section 6.2, of the Off-Site Dose Calculation Manual.
- B. Required detection capabilities for thermoluminescent dosimeters used for environmental measurements shall be in accordance with the recommendations of Regulatory Guide 4.13.
- C. The LLD is defined in Part II of the Off-Site Dose Calculation Manual.

Table 5.4 - Reporting Levels for Radioactivity Concentrations in Environmental Samples ^A

Sample	Units	H-3	Mn-54	Fe-59	Co-58	Co-60	Zn-65	Zr-95	Nb-95	Cs-134	Cs-137	Ba-140 La-140
Water	pCi/L	2.0E+04	1.0E+03	4.0E+02	1.0E+03	3.0E+02	3.0E+02	4.0E+02	4.0E+02	3.0E+01	5.0E+01	2.0E+02
Fish	pCi/kg (wet)	---	3.0E+04	1.0E+04	3.0E+04	1.0E+04	2.0E+04	---	---	1.0E+03	2.0E+03	---
Milk	pCi/L	---	---	---	---	---	---	---	---	6.0E+01	7.0E+01	3.0E+02
Airborne Particulates	pCi/m ³	---	---	---	---	---	---	---	---	1.0E+01	2.0E+01	---
Grass or Broad Leaf Vegetation/ Vegetables or Food Products	pCi/kg (wet)	---	---	---	---	---	---	---	---	1.0E+03	2.0E+03	---

A. A Non-routine report shall be submitted when more than one of the radionuclides listed above are detected in the sampling medium and:

$$\frac{\text{Concentration 1}}{\text{Reporting Level 1}} + \frac{\text{Concentration 2}}{\text{Reporting Level 2}} + \frac{\text{Concentration 3}}{\text{Reporting Level 3}} + \dots \geq 1.0$$

When radionuclides other than those listed above are detected and are the result of Facility effluents, this report shall be submitted if the potential annual dose to a member of the general public is equal to or greater than the dose objectives of Part I, Section 4.1 and 4.2, of the Off-Site Dose Calculation Manual. This report is not required if the measured level of radioactivity was not the result of Facility effluents; however, in such an event, the condition shall be reported and described in the Annual Radiological Environmental Operating Report.

5.2 Land Use Survey

5.2.1 Limiting Condition for Operation

A. A Land Use Survey shall identify the location of the nearest milk animal, nearest meat animal, nearest vegetable garden, nearest groundwater source and the nearest residence in each of the 16 cardinal sectors within a distance of five miles. The survey shall be conducted under the following conditions:

1. Within a one-mile radius from the Facility site, enumeration by door-to-door or equivalent counting techniques.
2. Within a Five-mile radius, enumeration may be conducted door-to-door or by using referenced information from county agricultural agents or other reliable sources.

APPLICABILITY: At all times

ACTION:

- a. If it is learned from this survey that milk animals, vegetable gardens and resident receptors are present at a location which yields a calculated dose greater than 20% from previously sampled location(s), the new location(s) shall be added to the monitoring program. Milk and vegetable garden sampling location(s) having the lowest calculated dose may then be dropped from the monitoring program at the end of the grazing and/or growing season during which the survey was conducted and the new location added to the monitoring program. Groundwater monitoring is based on a determination if source(s) are potentially affected by facility operations. Modifications to the air monitoring locations, vegetable garden sampling locations, and milk sampling locations will be made as soon as practicable. The Nuclear Regulatory Commission shall be notified of modifications to the program in the Annual Radiological Environmental Operating Report (Section 6.2).

5.2.1A.2 (continued)

- b. If it is learned from this survey that a pathway for dose to a MEMBER OF THE GENERAL PUBLIC no longer exists, an additional pathway has been identified or site specific factors affecting the dose calculations for a pathway have changed, then this information should be documented in the Land Use Survey, the Annual Radiological Environmental Operating Report and the Annual Radioactive Effluent Release Report. This information can be used to increase the accuracy of the dose models for the Annual Radioactive Effluent Release Report as well as dose estimates performed during the reporting period (i.e., quarterly dose estimates).

5.2.2 Surveillance Requirements

- A. A land use survey shall be conducted once per 24 months between the dates of June 1 and October 1. The results of the land use survey shall be submitted to the Nuclear Regulatory Commission in the Annual Radiological Environmental Operating Report (Section 6.2) for the year it was performed.

5.3 Interlaboratory Comparison Program

5.3.1 Limiting Condition for Operation

- A. Analyses shall be performed on radioactive materials as part of an Interlaboratory Comparison Program that has been approved by the Nuclear Regulatory Commission.

APPLICABILITY: At all times

ACTION:

1. With analysis not being performed as required above, report the corrective actions taken to prevent a recurrence to the Commission in the Annual Radiological Environmental Operating Report (Section 6.2).

5.3.2 Surveillance Requirements

- A. The results of these analyses shall be included in the Annual Radiological Environmental Operating Report (Section 6.2).

6.0 ADMINISTRATIVE CONTROLS

6.1 Responsibilities

- 6.1.1 FCS RP/Chemistry Department is responsible for the implementation and maintenance of the Off-Site Dose Calculation Manual.
- 6.1.2 ISFSI Shift Supervisor (ISS) is responsible for the compliance with the Off-Site Dose Calculation Manual in the operation of Fort Calhoun Station.

6.2 Radioactive Effluent Reporting Requirements

The reporting requirements for radioactive effluents stated in this Section are to provide assurance that the limits set forth in Part I of the Off-Site Dose Calculation Manual are complied with. These reports will meet the requirements for documentation of radioactive effluents contained in 10 CFR Part 50.36a; Reg. Guide 1.21, Rev. 2; Reg. Guide 4.8, Table 1; and Reg. Guide 1.109, Rev. 1.

6.2.1 Annual Radioactive Effluent Release Report

A report covering the operation of the Fort Calhoun Station during the previous calendar year shall be submitted prior to May 1 of each year per the requirements of QATR Appendix E, E.4.1 and 10 CFR Part 50.

The Radioactive Effluent Release Report shall include:

- A. A summary of the quantities of radioactive liquid and airborne effluents and solid waste released from the facility as outlined in Regulatory Guide 1.21, Revision 2.
- B. A summary of the historical average meteorological data that provides joint frequency distributions of wind direction and wind speed by atmospheric stability class will be included in the annual report.
- C. An assessment of radiation doses from the radioactive liquid and airborne effluents released from the unit during each calendar quarter as outlined in Regulatory Guide 1.21, Revision 2. The assessment of radiation doses shall be performed in accordance with calculational methodology of the Regulatory Guide 1.109, Revision 1.
- D. Changes to the Process Control Program (PCP) or to the Offsite Dose Calculation Manual (ODCM) made during the reporting period. Each change shall be identified by markings in the margin of the affected pages clearly indicating the area of the page that was changed and shall indicate the date the change was implemented.

6.2.1 (continued)

- E. A list and description of abnormal releases or abnormal discharges from the site to unrestricted areas of radioactive materials in gaseous and liquid effluents made during the reporting period.
- F. An explanation of why instrumentation designated in Part I, Sections 3.1.1 and 3.2, of the Off-Site Dose Calculation Manual, was not restored to FUNCTIONAL status within 30 days.
- G. A description of any major design changes or modifications made to the Liquid and/or Gaseous Radwaste Treatment Systems or Ventilation Exhaust Systems during the reporting period.
- H. An explanation of why the liquid and/or gaseous radwaste treatment systems were not FUNCTIONAL, causing the limits of specifications 4.1.3A and 4.2.3A to be exceeded.
- I. The results of sampling from offsite and onsite groundwater wells per the Site Groundwater Protection Plan. **[AR 39127]**
- J. Non-routine planned discharges (e.g., discharges from remediation efforts like pumping contaminated groundwater from a leak).

6.2.2 Annual Radiological Environmental Operating Report

The Annual Radiological Environmental Operating Report for the previous one year of operation shall be submitted prior to May 1 of each year. This report contains the data gathered from the Radiological Environmental Monitoring Program. The content of the report shall include:

- A. Summarized and tabulated results of the radiological environmental sampling/analysis activities following the format of Regulatory Guide 4.8, Table 1. In the event that some results are not available, the report shall be submitted noting and explaining the reasons for the missing results. The missing data shall be submitted as soon as possible in a supplementary report.
- B. Interpretations and statistical evaluation of the results, including an assessment of the observed impacts of the facility operation and environment.
- C. The results of participation in a NRC approved Interlaboratory Comparison Program.
- D. The results of land use survey required by Section 5.2.
- E. A map of the current environmental monitoring sample locations.

6.2.3 Independent Spent Fuel Storage Installation Annual Radioactive Effluent Release Report.

The Independent Spent Fuel Storage Installation Annual Radioactive Effluent Release Report must be submitted within 60 days after the end of the 12-month monitoring period, per 10 CFR 72.44(d)(3).

- A. A Summary of the quantity of each of the principal radionuclides released to the environment in liquid and in gaseous effluents during the previous 12 months and such other information as may be required by the Commission to estimate maximum potential radiation dose commitment to the public resulting from effluent releases.

6.2.4 Special Report

If the limits or requirements of Sections 4.1.2A, 4.1.3A, 4.2.2A, 4.3.1A, and/or 5.1.1A.3 and/or 5.1.1A.4 are exceeded, a Special Report shall be issued to the Commission, pursuant to QATR Appendix E, E.2. This report shall include: **[AR 39127]**

- A. The results of an investigation to identify the causes for exceeding the specification.
- B. Define and initiate a program of action to reduce levels to within the specification limits.
- C. The report shall also include an evaluation of any release conditions, environmental factors, or other aspects necessary to explain the condition.

6.2.5 EPA 40 CFR Part 190 Reporting Requirements

With the calculated dose from the release of radioactive materials in liquid or gaseous effluents exceeding twice the limits of dose from specifications 4.1.2A or 4.2.2A, calculations shall be made including direct radiation calculations, to prepare and submit a special report to the Commission within 30 days and limit the subsequent releases such that the dose to any real individual from uranium fuel cycle sources is limited to ≤ 25 mrem to the total body or any organ (except thyroid, which is limited to ≤ 75 mrem) over the calendar year. This special report shall include an analysis which demonstrates that radiation exposures to any member of the public from uranium fuel cycle sources (including all effluent pathways and direct radiation) are less than the 40 CFR Part 190 standard. Otherwise, obtain a variance from the Commission to permit releases which exceed the 40 CFR Part 190 standard. The submittal of the report is to be considered a timely request and a variance is granted pending the final action on the variance request from the Commission.

6.2.6 ISFSI 10 CFR Part 72.104 Reporting Requirements

The regulatory requirements of 10CFR20, 10CFR72 and 40CFR190 each limit total dose to individual members of the public without regard to specific pathways. The only significant exposure pathways for light water reactors included in 10CFR20, 10CFR72 and 40CFR190 not addressed by 10CFR50 Appendix I are the direct radiation pathway and exposure from on-site activity by members of the public.

The 10CFR72.104 dose limits are the same as those specified in 40CFR190. ISFSI dose contribution is in the form of direct radiation as no liquid or gas releases are expected to occur. If the dose limits of 40CFR190 or 10CFR72.104 are exceeded, a special report to the NRC, as well as an appropriate request for exemption/variance, is required to be submitted to the NRC.

The requirement that the dose limits of 10CFR72.104 apply to any 'real individual' is controlled for ISFSI activities in the ISFSI 72.212 report. Therefore, for the purposes of analyzing dose from the ISFSI, the member of the public as defined in 40CFR190 is the same as for the 'real individual'.

The external Total Body Dose is comprised of:

- 1) Total Body Dose due to noble gas radionuclides in gaseous effluents
- 2) Dose due to radioactive waste and the ISFSI
- 3) Total Body Dose due to radioactivity deposited on the ground (this dose is accounted for in the determination of the non-noble gas dose and is not considered here)

Dose from onsite storage (such as the ISFSI) is given by:

$D_{osf} = \max \text{ of } :$

(TLD dose from indicator TLD i – average of all background TLDs)
* occupancy factor at TLD i

Neutron dose is found by multiplying gamma dose by a neutron/gamma ratio determined from other site TLDs around the ISFSI.

The Total Body Dose, external is given by:

$D_{ext} = D_{tb} + D_{osf}$

Where D_{ext} is the external dose

D_{tb} is the total body dose

D_{osf} is the dose from on-site storage

The Total Dose is then given by:

$D_{tot} = D_{ext} + D_{liq} + D_{nng}$

Where D_{tot} is the total dose

D_{ext} is the external dose

D_{liq} is the dose from liquid effluents

D_{nng} is the dose from non-noble gases

Dose Limits

Total Body, annual	25 mrem
Thyroid, annual	75 mrem
Other Organs, annual	25 mrem

6.3 Change Mechanism

The Off-Site Dose Calculation Manual is the controlling document for all radioactive effluent releases. It is defined as a procedure under the guidance of QATR Section 5. It will be revised and reviewed by an Independent Safety Review (ISR) and approved by the Plant Manager in accordance with QATR Appendix E, E.1.2. All changes to the Off-Site Dose Calculation Manual will be forwarded to the Nuclear Regulatory Commission during the next reporting period for the Annual Radioactive Effluent Release Report in accordance with the requirements of QATR Appendix E, E.1.2.

6.4 Meteorological Data

The 5 year historical Average χ/Q is utilized to determine the concentrations of radionuclides at the unrestricted area boundary. It is also the factor used in conjunction with the parameters and methodologies in Part II, of the Off-Site Dose Calculation Manual to determine unrestricted area dose on a quarterly bases or as needed. It is based on an average of the highest calculated sector χ/Q values, using all 16 sectors for previous multiple years Annual Radioactive Effluent Release Reports, and the XOQDOQ plume trajectory model. An additional 10 percent will be added to the average for unrestricted area dose estimates performed quarterly for conservatism. XOQDOQ model conforms with the Nuclear Regulatory Commissions Regulatory Guide 1.111.

Historical average meteorological data will be utilized in the preparation of the Annual Radioactive Effluent Release Report. Prior years of data is used to calculate the joint frequency table, the dispersion coefficients and deposition factors in all 16 sectors. These are used in the calculation of doses to individuals in unrestricted areas as a result of the operation of Fort Calhoun Station. The models used, GASPAR 2 and LADTAP 2, meet the intent of Nuclear Regulatory Commissions Reg. Guide 1.109 and 1.21 for the reporting of doses due to routine radioactive effluent releases.

6.5 References

- 6.5.1 Regulatory Guide 1.109, Rev. 1 - Calculation of Annual Dose to man from Routine Releases of Reactor Effluents for the purpose of evaluation compliance with 10 CFR Part 50, Appendix I
- 6.5.2 Regulatory Guide 1.111, Rev. 1 - Methods for Estimating Atmospheric Transport and Dispersion of Gaseous Effluents in Routine Releases from Light-Water-Cooled Reactors.
- 6.5.3 Regulatory Guide 1.113, Rev. 1 - Estimating Aquatic Dispersion of Effluents from Accidental and Routine Releases for the purpose of Implementing Appendix I.
- 6.5.4 Regulatory Guide 4.8, Environmental Technical Specification for Nuclear Power Plants.
- 6.5.5 NRC Branch Technical Position, March 1978
- 6.5.6 NUREG-0133 - Preparation of Radiological Effluent Technical Specifications for Nuclear Power Plants.
- 6.5.7 NUREG-1301 - Offsite Dose Calculation Manual Guidance.
- 6.5.8 Regulatory Guide 1.21, Rev. 2 - Measuring, Evaluating, and Reporting Radioactivity in solid wastes and Releases of Radioactivity Materials in Liquid and Gaseous Effluents from Light-Water-Cooled Nuclear Power Plants.
- 6.5.9 Code of Federal Regulations, Title 10, Part 20
- 6.5.10 Code of Federal Regulations, Title 10, Part 50
- 6.5.11 Code of Federal Regulations, Title 10, Part 72
- 6.5.12 Code of Federal Regulations, Title 40, Part 190
- 6.5.13 Fort Calhoun Revised Environmental Report (Unit No. 1)-1972
- 6.5.14 NO-FC-10, Quality Assurance Topical Report
- 6.5.15 Defueled Safety Analysis Report
- 6.5.16 AR 12357, Implement Recommendations of Memo FC-0133-92, Part I, Table 3.2.1 Action 4, of the Off-Site Calculation Manual
- 6.5.17 AR 39127, NEI Industry Initiative on Groundwater Protection

- 6.5.18 Regulatory Guide 4.1, Rev. 2 – Radiological Environmental Monitoring for Nuclear Power Plants
- 6.5.19 FC-19-001, ODCM rev 29 Change Support Document
- 6.5.20 FC-18-005, Habits of the Real Individual in Vicinity of Fort Calhoun Station, X/Q, Direct Radiation Dose Calculation

7.0 **BASIS**

7.1 Instrumentation

7.1.1 Radioactive Liquid Effluent Instrumentation

The Radioactive liquid effluent instrumentation is provided to monitor and control, as applicable, the releases of radioactive material in liquid effluents during actual or potential releases of liquid effluents. The Alarm/Trip setpoints for these instruments shall be calculated in accordance with Part II of the Offsite Dose Calculation Manual to ensure that the alarm/trip will occur prior to exceeding the limits of 10 CFR Part 20. The FUNCTIONALITY and use of this instrumentation is consistent with the requirements of DSAR-Appendix G Criterion 17 – Monitoring Radioactive Releases, Criterion 18 – Monitoring Fuel and Waste Storage, and Criterion 70 – Control of Release of Radioactivity to the Environment.

7.1.2 Radioactive Gaseous Effluent Instrumentation

The Radioactive gaseous effluent instrumentation is provided to monitor and control, as applicable, the releases of radioactive material in gaseous effluents during actual or potential releases of gaseous effluents.

7.2 Radioactive Effluents

7.2.1 Radioactive Liquid Effluents

A. Concentration

This specification is provided to ensure that the concentration of radioactive materials released in liquid waste effluents from the site to unrestricted areas will be less than 10 times the concentration levels specified in 10 CFR Part 20, Appendix B, Table II, Column 2. This limitation provides additional assurance that the levels of radioactive materials in bodies of water outside the site will result in exposures within (1) the Section II.A design objectives of Appendix I, 10 CFR Part 50, and (2) the limits of 10 CFR Part 20.1001-20.2401 to the population.

B. Dose

This specification is provided to implement the requirements of Sections II.A, III.A and IV.A of Appendix I, 10 CFR Part 50. The Limiting Condition for Operation implements the guides set forth in Section II.A of Appendix I. The ACTION statements provide the required operating flexibility and at the same time implement the guides set forth in Section IV.A of Appendix I to assure that the releases of radioactive material in liquid effluents will be kept "as low as is reasonably achievable". Also, with fresh water sites with drinking water supplies which can be potentially affected by facility operations, there is reasonable assurance that the operation of the facility will not result in radionuclide concentrations in the finished drinking water that are in excess of the requirements of 40 CFR Part 141. The dose calculation methodology and parameters in Part II of the Off-Site Dose Calculation Manual, implement the requirements in Section III.A that conformance with the guides of Appendix I is to be shown by calculational procedures based on models and data such that the actual exposure of an individual through appropriate pathways is unlikely to be substantially underestimated. The equations specified in Part II of the Off-Site Dose Calculation Manual, for calculating the doses due to the actual release rates of radioactive material in liquid effluents are consistent with the methodology provided in Regulatory Guide 1.109, "Calculation of Annual Doses to Man from Routine Releases of Reactor Effluents for the Purpose of Evaluating Compliance with 10 CFR Part 50, Appendix I," Revision 1, October 1977, and Regulatory Guide 1.113, "Estimating Aquatic Dispersion of Effluents from Accidental and Routine Reactor Releases for the Purpose of Implementing Appendix I," April 1977.

C. Liquid Waste Treatment System

The FUNCTIONALITY of the liquid radwaste treatment system ensures that this system will be available for use whenever liquid effluents require treatment prior to release to the environment. The requirement that appropriate portions of this system be used when specified provides assurance that the releases of radioactive materials in liquid effluents will be kept "as low as is reasonably achievable". This specification implements the requirements of 10 CFR Part 50.36a, General Design Criterion 60 of Appendix A to 10 CFR Part 50 and design objective and in Section II.D of Appendix I to 10 CFR Part 50. The specified limits governing the use of appropriate portions of the liquid radwaste treatment system were specified to ensure the design objectives set forth in Section II.A of Appendix I, 10 CFR Part 50 for liquid effluents are not exceeded.

D. Liquid Holdup Tanks

Restricting the quantity of radioactive material contained in the specified tanks provides assurance that in the event of an uncontrolled release of the tanks' contents, the resulting concentrations would be less than the limits of 10 CFR Part 20, Appendix B, Table II, Column 2, at the nearest potable water supply and the nearest surface water supply in an unrestricted area.

7.2.2 Radioactive Gaseous Effluents

A. Concentration

This specification, in conjunction with Steps 4.2.2A, is provided to ensure that the dose at or beyond the Site Boundary from gaseous effluents will be within the annual dose limits of 10 CFR Part 20 for MEMBERS OF THE PUBLIC. The release rate of radioactive material in airborne effluents shall be controlled such that the instantaneous concentrations for these radionuclides do not exceed the values specified in 10 CFR Part 20 for airborne effluents at the unrestricted area boundary.

B. Dose - Radioactive Material in Particulate Form with Half-Lives Greater than Eight Days (Other than Noble Gases) and Tritium

This specification is provided to implement the requirements of Sections II.C, III.A and IV.A of Appendix I, 10 CFR Part 50. The Limiting Condition For Operation implements the guides set forth in Section II.C of Appendix I. The ACTION statements provide the required operating flexibility and at the same time implement the guides set forth in Section IV.A of Appendix I assure that the releases of radioactive material in gaseous effluents will be kept as low as is reasonably achievable. The surveillance requirements implement the requirements in Section III.A of Appendix I that conform with the guides of Appendix I to be shown by calculational procedures based on models and data such that the actual exposure of an individual through the appropriate pathways is unlikely to be substantially underestimated. The release rate specification for radioactive material in particulate form with half-lives greater than eight days (other than noble gases) and tritium are dependent on the existing radionuclide pathways to man in the areas at or beyond the site boundary. The pathways that were examined in the development of these calculations were: 1) individual inhalation of airborne radionuclides, 2) deposition of radionuclides onto green leafy vegetation with subsequent consumption by man, 3) deposition onto grassy areas where milk animals and meat producing animals graze with consumption of the milk and meat by man, and 4) deposition on the ground with subsequent exposure of man.

C. Gaseous Waste Treatment

The FUNCTIONALITY of the ventilation exhaust treatment systems ensures that the systems will be available for use whenever gaseous effluents require treatment prior to release to the environment. The requirement that appropriate portions of this system be used when specified provides assurance that the releases of radioactive materials in gaseous effluents will be kept as low as is reasonably achievable. This specification implements the requirements of 10 CFR Part 50.36a, General Design Criterion 60 of Appendix A to 10 CFR Part 50 and design objective and in Section II.D of Appendix I to 10 CFR Part 50. The specified limits governing the use of appropriate portions of the systems were specified to ensure the design objectives set forth in Section II.B and II.C of Appendix I, 10 CFR Part 50 for gaseous effluents are not exceeded.

D. Total Dose - Uranium Fuel Cycle

This specification is provided to meet the dose limitations of 40 CFR Part 190 that have been incorporated into 10 CFR Part 20.1301(d). This requires the preparation and submittal of a Special Report whenever the calculated doses due to releases of radioactivity and to radiation from uranium fuel cycle sources exceed 25 mRems to the total body or any organ, except the thyroid, which shall be limited to less than or equal to 75 mRems. It is highly unlikely that the resultant dose to a MEMBER OF THE PUBLIC will exceed the dose limits of 40 CFR Part 190 if the facility remains within twice the dose design objectives of Appendix I, 10 CFR Part 50, and if direct radiation doses (including outside storage tanks, etc.) are kept small. The Special Report shall describe a course of action that should result in the limitation of the annual dose to a MEMBER OF THE PUBLIC to within the 40 CFR Part 190 limits. For purposes of the Special Report, it may be assumed that the dose commitment to the MEMBER OF THE PUBLIC from other uranium fuel cycle sources is negligible, with the exception that dose contributions from other nuclear fuel cycle facilities at the same site or within a radius of 8 km must be considered. If the dose to any MEMBER OF THE PUBLIC is estimated to exceed the requirements of 40 CFR Part 190, the Special Report, with a request for a variance (provided the release conditions resulting in violation of 40 CFR Part 190 have not already been corrected), in accordance with the provisions of 40 CFR Part 190.11 and 10 CFR Part 20.2203(a)(4) and 20.2203(b) is considered to be a timely request and fulfills the requirements 40 CFR Part 190 until NRC staff action is completed. The variance only relates to the limits of 40 CFR Part 190, and does not apply in any way to the other requirements for dose limitation of 10 CFR Part 20. An individual is not considered a MEMBER OF THE PUBLIC during any period in which he/she is engaged in carrying out any operation that is part of the nuclear fuel cycle. Demonstration of compliance with the limits of 40 CFR Part 190 or with the design objectives of Appendix I to 10 CFR Part 50 will be considered to demonstrate compliance with the 0.1 rem limit of 10 CFR Part 20.1301.

7.3 Radiological Environmental Monitoring

7.3.1 Monitoring Program

The radiological environmental monitoring program required by this specification provides measurements of radiation and radioactive materials in those exposure pathways and for radionuclides which lead to the highest potential radiation exposures of individuals resulting from the station operation. This monitoring program thereby supplements the radiological effluent monitoring program by verifying that the measurable concentrations of radioactive materials and levels of radiation are not higher than expected on the basis of the effluent measurements and modeling of the environmental exposure pathways. The initially specified monitoring program was effective for at least the first three years of commercial operation. Following this period, program changes are initiated based on operational experience.

7.3.2 Land Use Survey

This specification is provided to ensure that changes in the use of unrestricted areas are identified and that modifications to the monitoring program are made if required by the results of this survey. The frequency of the Land Use Survey has been reduced to a biennial requirement in site procedures because persons knowledgeable in land use census monitor usage characteristics perform routine REMP sampling. This approach allows knowledge gained during sample collection to be integrated into the program, maintaining its effectiveness. The best survey information from door to door, aerial or consulting with local agricultural authorities, or equivalent, shall be used. This survey satisfies the requirements of Section IV.B.3 of Appendix I to 10 CFR Part 50. Restricting the survey to gardens of greater than 500 square feet provides assurance that significant exposure pathways via leafy vegetables will be identified and monitored since a garden of this size is the minimum required to produce the quantity (26 kg/year) of leafy vegetables assumed in Regulatory Guide 1.109 for consumption by a child. To determine this minimum garden size, the following assumptions were used, 1) that 20% of the garden was used for growing broad leaf vegetation (i.e., similar to lettuce and cabbage), and 2) a vegetation yield of 2 kg/m².

For milk, the survey is restricted to only milk animals (cow or goat) producing milk for human consumption. Air monitoring stations are strategically located to monitor the resident receptors who could potentially receive the highest doses from airborne radioactive material. For groundwater, samples shall be taken when sources are determined to potentially be affected by facility operations, and when sources are tapped for drinking or irrigation purposes in areas where the hydraulic gradient or recharge properties are suitable for contamination. Guidance provided in the Branch Technical Position and QATR Appendix E, E.3.1.3 is used to meet the intent of NUREG-1301.

7.3.3 Interlaboratory Comparison Program

The requirement for participation in an Interlaboratory Comparison Program is provided to ensure that independent checks on the precision and accuracy of the measurements of radioactive material in environmental sample matrices are performed as part of a quality assurance program for environmental monitoring in order to demonstrate that the results are reasonably valid for the purposes of Section IV.B.2 of Appendix I to 10 CFR Part 50.

7.4 Abnormal Release or Abnormal Discharge Reporting

7.4.1 Specific information should be reported concerning abnormal (airborne and/or liquid) releases on site and abnormal discharges to the unrestricted area. The report should describe each event in a way that would enable the NRC to adequately understand how the material was released and if there was a discharge to the unrestricted area. The report should describe the potential impact on the ingestion exposure pathway involving surface water and ground water, as applicable. The report should also describe the impact (if any) on other affected exposure pathways (e.g., inhalation from pond evaporation).

7.4.2 The following are the thresholds for reporting abnormal releases and abnormal discharges in the supplemental information section:

- A. Abnormal release or Abnormal Discharges that are voluntarily reported to local authorities under NEI 07-07, Industry Ground Water Protection Initiative. **[AR 39127]**
- B. Abnormal release or Abnormal discharges estimated to exceed 100 gallons of radioactive liquid where the presence of licensed radioactive material is positively identified (either in the on-site environs or in the source of the leak or spill) as greater than the minimum detectable activity for the laboratory instrumentation.
- C. Abnormal releases to on-site areas that result in detectable residual radioactivity after remediation.
- D. Abnormal releases that result in a high effluent radiation alarm without an anticipated trip occurring.
- E. Abnormal discharges to an unrestricted area.

7.4.3 Information on Abnormal releases or Abnormal discharges should include the following, as applicable:

- Date and duration
- Location
- Volume
- Estimated activity of each radionuclide
- Effluent monitoring results (if any)
- On-site monitoring results (is any)
- Depth to the local water table
- Classification(s) of subsurface aquifer(s) (e.g., drinking water, unfit for drinking water, not used for drinking water)
- Size and extent of any ground water plume
- Expected movement/mobility of any ground water plume
- Land use characteristics (e.g., water used for irrigation)
- Remedial actions considered or taken and results obtained
- Calculated member of the public dose attributable to the release
- Calculated member of the public dose attributable to the discharge
- Actions taken to prevent recurrence, as applicable
- Whether the NRC was notified, the date(s), and the contact organization

PART II
CALCULATIONS

1.0 EFFLUENT MONITOR SETPOINTS

1.1 Liquid Effluents

- 1.1.1 There is one liquid discharge pathway to the Missouri River. The pathway originates with the radioactive liquid waste processing system (monitor or hotel tanks). This pathway empties into the circulating water system which discharges to the Missouri River (see Figure 1). Figure 2 depicts the liquid discharge pathway and associated radiation monitor. Figure 3 depicts the methods of liquid effluent treatment.
- 1.1.2 The flowrate for dilution water varies with the number raw water pumps in service
- 1.1.3 QATR Appendix E, E.2.1.3.b establishes the administrative control limit on concentration of radioactive material, other than dissolved or entrained noble gases, released in liquid effluents to unrestricted areas conforming to ten times 10 CFR Part 20.1001-20.2401, Appendix B, Table 2, Column 2.
- 1.1.4 The liquid effluent monitoring instrumentation ALERT setpoints shall be established low enough to ensure that the concentration of radioactive material released in liquid effluents at site discharge will be less than the concentrations specified in 10 CFR Part 20, Appendix B, Table 2, Column 2.
- 1.1.5 The liquid effluent monitoring instrumentation HIGH ALARM setpoints shall be established low enough to ensure that the concentration of radioactive material released in liquid effluents at site discharge will be less than 10 times the concentrations specified in 10 CFR Part 20, Appendix B, Table 2, Column 2.
- 1.1.6 Cs-137 is used to calibrate the liquid effluent monitors.

1.1.7 Liquid Effluent Radiation Monitor

A. Overboard Discharge Header Monitor (RM-055)

1. This process radiation monitor provides control of the waste monitor tank effluent by monitoring the overboard header prior to its discharge into the circulating water discharge tunnel. The concentration of activity at discharge is controlled below ten times the 10 CFR Part 20 limit of $1.0E-06$ $\mu\text{Ci/ml}$ at site discharge for unidentified isotopes by the high alarm setpoint which closes the overboard flow control valve.
2. The following calculations for maximum concentration and alarm setpoints are valid for radioactive liquid releases of monitor tank discharge.
3. The maximum allowable concentration in the overboard discharge header is:

$$C_{MAX} = \frac{(1.0E - 05 \mu\text{Ci/ml}) (F)}{f}$$

Where:

- $1.0E-05$ $\mu\text{Ci/ml}$ = Ten times 10 CFR Part 20 Limit for unidentified radionuclides at site discharge (10 CFR Part 20, Appendix B, Note 2).
- F = Total dilution flow in the discharge tunnel (gpm). (Normal flow is based on 2 raw water pumps at 7,200 gpm total.)
- f = Maximum monitor tank discharge flow rate (gpm). (Normal monitor tank maximum flow is 15 gpm.)
- C_{MAX} = Maximum allowable activity in discharge header ($\mu\text{Ci/ml}$).

1.1.7A (continued)

The **High Alarm Setpoint** (CPM):

$$Setpoint = 0.75 \left[\left((K_3)(S_f)(C_{MAX}) \right) + B \right]$$

Where:

- 0.75 = An administrative correction factor which includes the following:
- 25% tolerance to account for the difference in detector sensitivity for the range of isotopes detected.
- S_f = Detector sensitivity factor (CPM/ μ Ci/ml). (Sensitivity based on Cs-137).
- K_3 = Allocation factor for Waste Liquid Releases (1)
- C_{MAX} = Maximum allowable concentration in discharge header (μ Ci/ml).
- B = Background (CPM)

The **Alert Setpoint** will be chosen less than or equal to one tenth (1/10) the value of the high alarm setpoint value so that significant increases in activity will be identified prior to exceeding an Unrestricted Area fractional sum of 1.0. It will also provide additional time for corrective actions prior to exceeding the Alarm Setpoint.

1.2 Airborne Effluents

1.2.1 There are multiple air effluent discharge pathways at the Fort Calhoun Station during decommissioning with three different mechanisms of release: Forced draft ventilation, Unventilated building release, and Open-air demolition.

- Forced draft ventilation uses installed or portable filtered ventilation units with a fan with a rated cfm as the release rate. Monitoring of forced draft ventilation includes utilizing presently installed system monitors such as RM-062, RM-052, and RM-043. When portable ventilation systems are used, the air particulate sample head shall directly sample the airborne effluent discharge flowpath.
- Unventilated building releases in which the dimension of an open doorway coupled with windspeed blowing through the doorway are used to calculate the release rate. Unventilated building releases shall be monitored with a portable air sampler located outside of the doorway at any time the door is open, and active decommissioning that could generate airborne is in progress.
- Open-air demolition releases are rubble and building debris containing low level radioactive material may be wind-blown as a release. Other Open-air releases may include building demolition in which the structure of the building is demolished to the point where it becomes inaccurate to use doorway area as a release point each location shall be documented as they are established. Airborne effluent monitoring during Open-air demolition shall be accomplished by placing 4 air samplers in 4 general opposing directions around the area to be sampled, placed in areas that will not obstruct decommissioning activities around the area.

Table 1 - Deleted

Figure 1 - Exclusion and Site Boundary Map

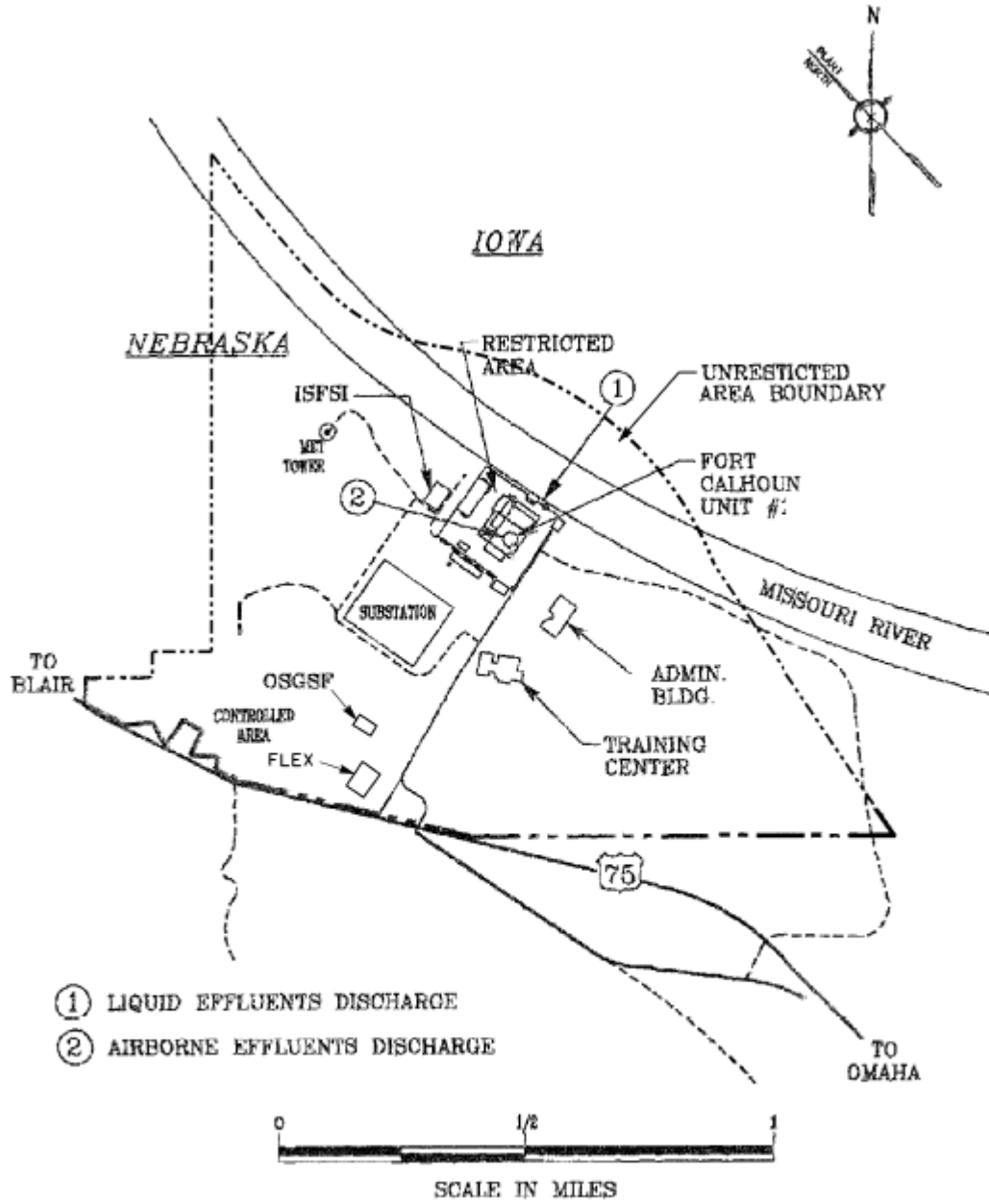

SITE BOUNDARY MAP

DRAWING FILE NO.
P-00414

Figure 2 - Liquid Radioactive Discharge Pathways

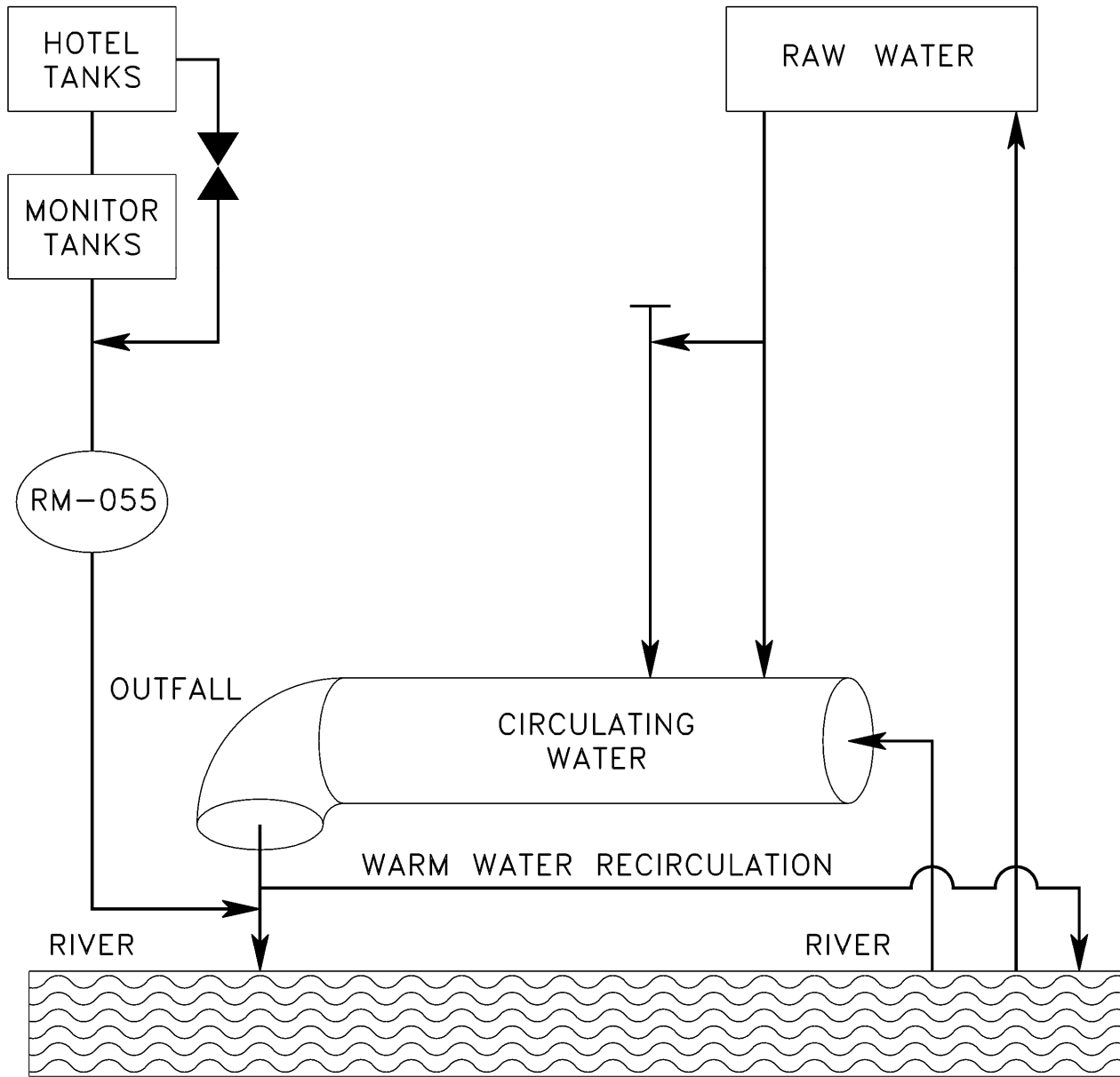

LIQUID RADIOACTIVE DISCHARGE PATHWAYS

DRAWING FILE NO.
P-00410

Figure 3 - Liquid Radioactive Waste Disposal System

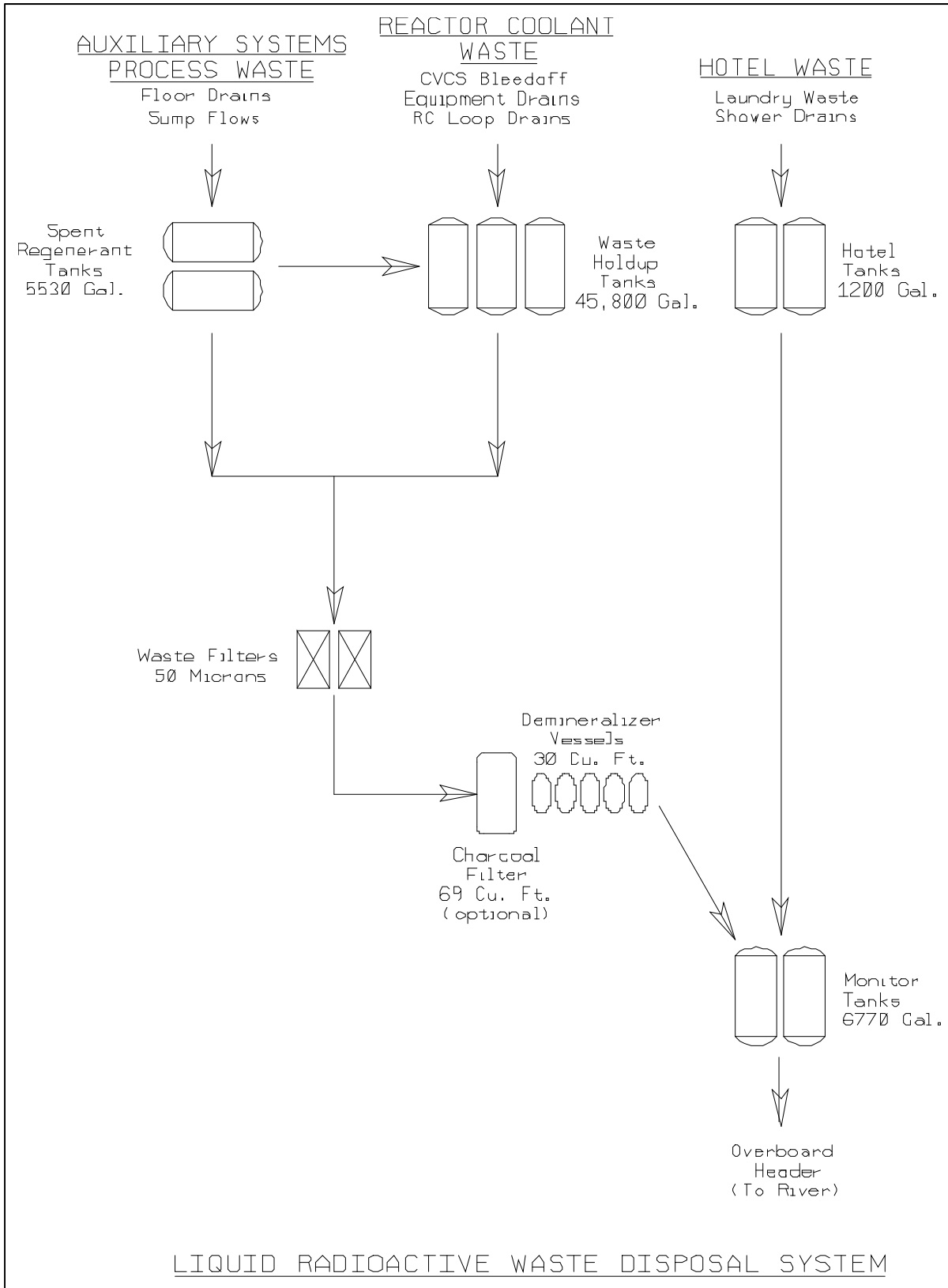
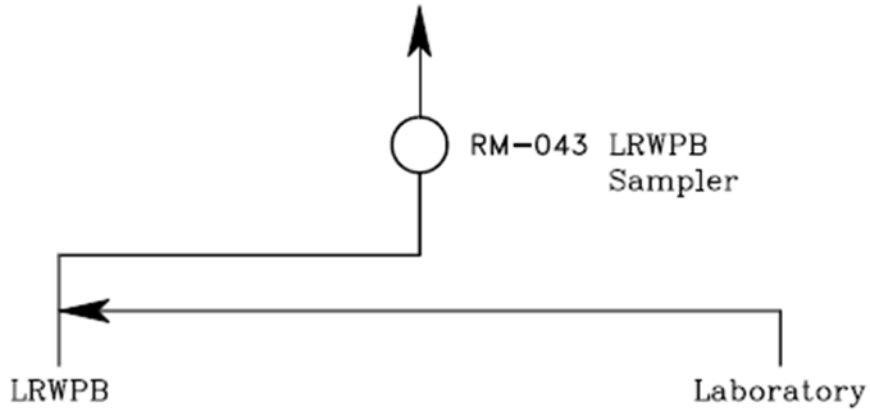
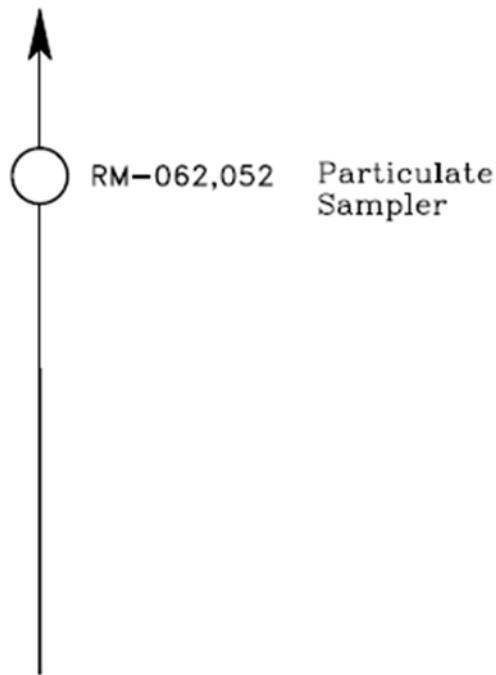

Figure 4 - Airborne Effluent Discharge Pathways



LABORATORY AND RADIOACTIVE WASTE PROCESSING BUILDING



AUXILIARY BUILDING EXHAUST STACK

Auxiliary Building Ventilation

AIRBORNE EFFLUENT DISCHARGE PATHWAYS

DRAWING FILE NO.
P-00411

Figure 4 - Airborne Effluent Discharge Pathways (continued)

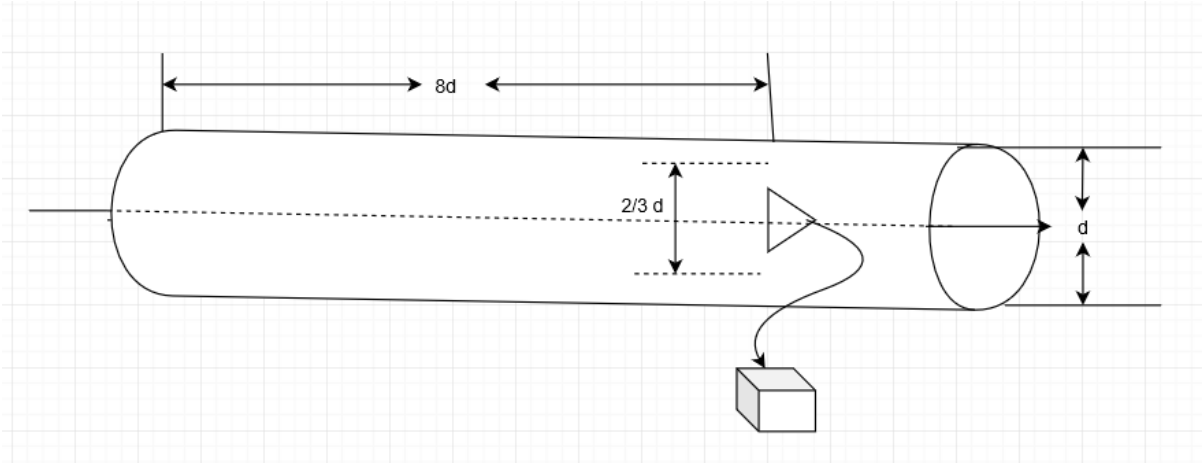
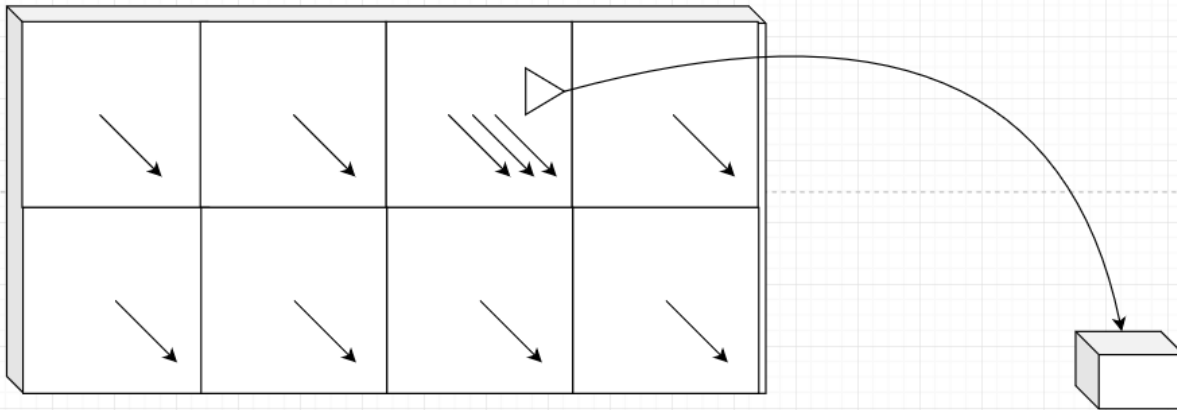
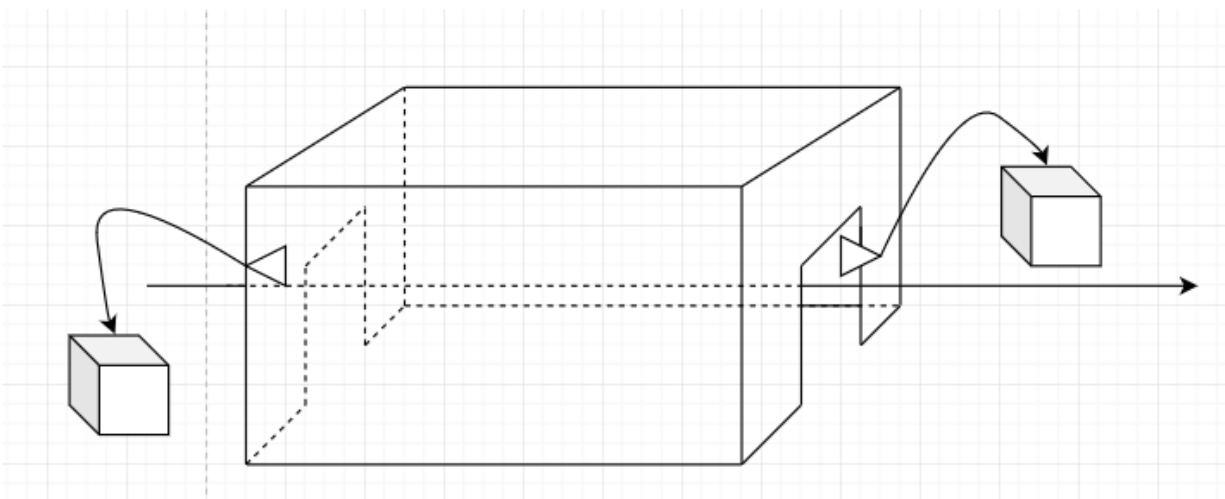
**FORCED DRAFT AIR SAMPLER WITH EXHAUST TRUNK DISCHARGE****FORCED DRAFT AIR SAMPLER WITH OUTLET PLENUM**

UNVENTILATED BUILDING RELEASE AIR SAMPLERS

Figure 4 - Airborne Effluent Discharge Pathways (continued)

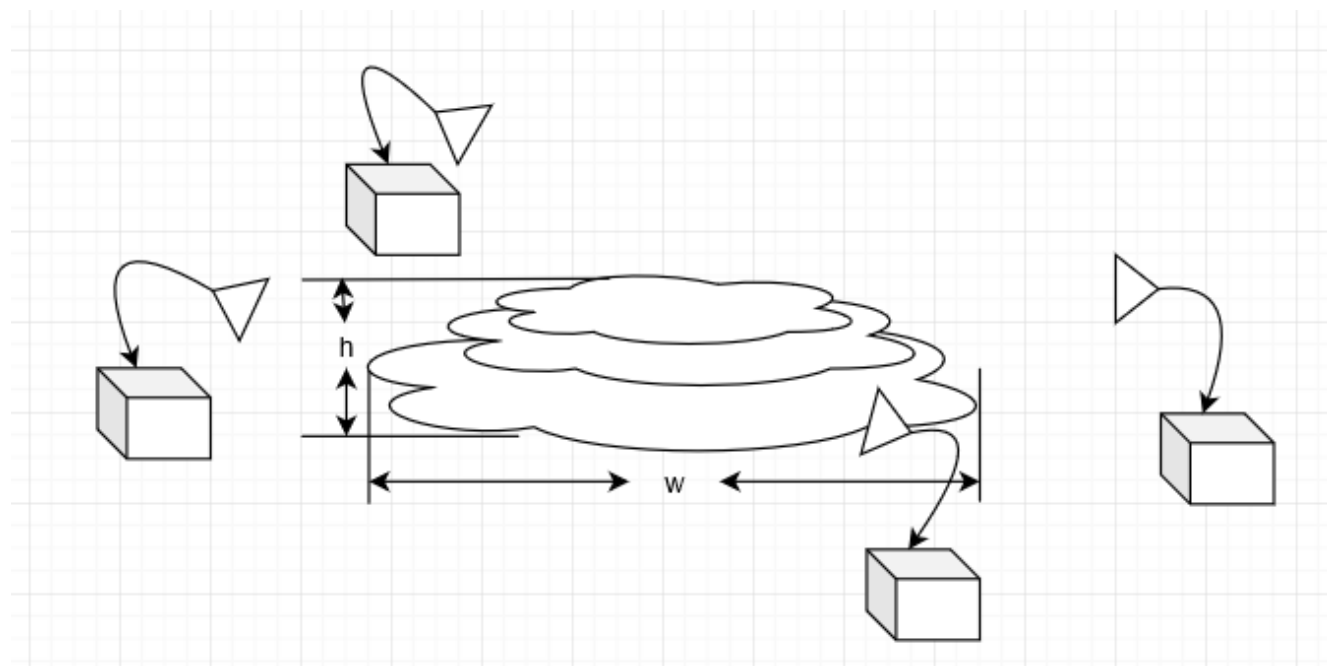

OPEN-AIR DEMOLITION AIR SAMPLERS

Figure 5 - Airborne Radioactive Waste Disposal System

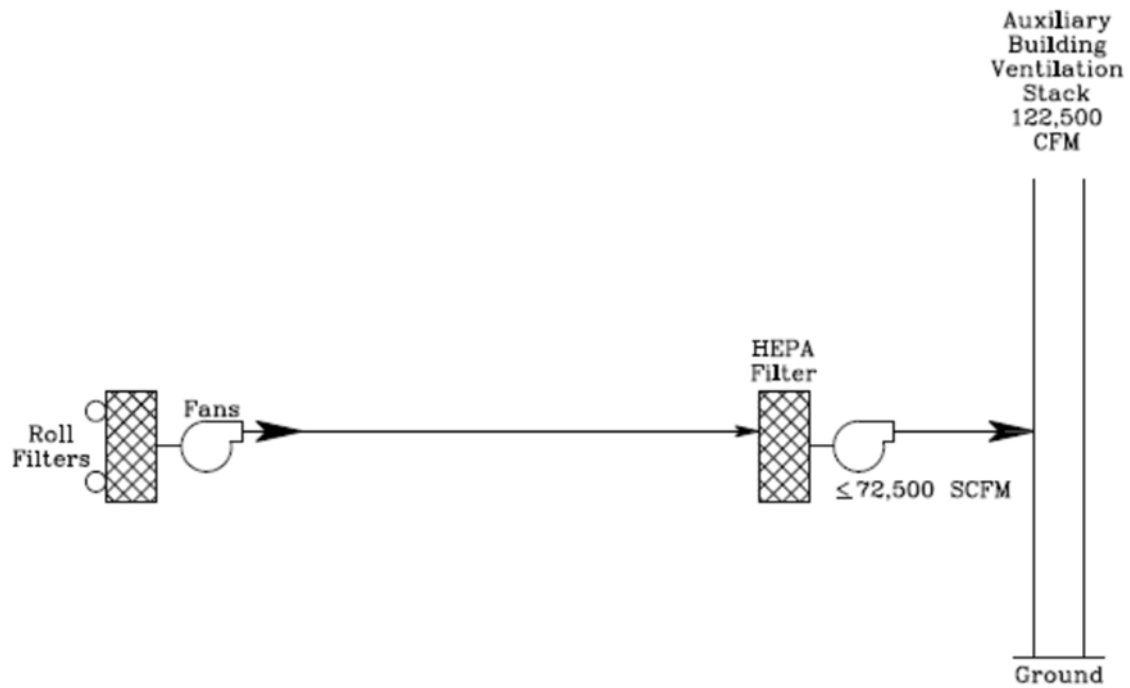

AIRBORNE RADIOACTIVE WASTE DISPOSAL SYSTEM

DRAWING FILE NO.
P-00412

2.0 EFFLUENT CONCENTRATIONS**2.1 Liquid Effluent Concentrations**

2.1.1 The concentration of radioactive material in liquid effluents (after dilution in the Circulating Water System) will be limited to the concentrations as specified in 10 CFR Part 20, Appendix B, Table 2, Column 2. For batch releases (Monitor and Hotel Waste Tanks) the analyses will be performed in accordance with Part I, Table 4.1, of the Off-Site Dose Calculation Manual, and the concentration of each radionuclide at site discharge will be calculated, based on the following equation:

$$A_i = \frac{a_i f}{F + f}$$

$$\text{and } \sum_{i=1}^n \frac{A_i}{wec_i} \leq 1$$

Radionuclide concentration at site discharge:

Where:

A_i = concentration at site discharge for radionuclide (I), in $\mu\text{Ci/ml}$.

a_i = concentration of radionuclide (I) in the undiluted effluent, in $\mu\text{Ci/ml}$.

f = undiluted effluent flowrate, in gpm.

F = total diluted effluent flowrate in gpm.

wec_i = water effluent concentration limit for radionuclide (I) per 10 CFR Part 20, Appendix B, Table 2, Column 2.

i	NOTE	i
	In addition to the above defined method, Notes 1 through 4 of 10 CFR Part 20, Appendix B, will also be applicable.	

2.2 Airborne Effluent Concentrations

2.2.1 The concentration at the unrestricted area boundary, due to airborne effluent releases, will be limited to less than Appendix B, Table 2, Column 1, values.

2.2.2 To determine the concentration and air effluent concentration (aec) fraction summation at the unrestricted area boundary, the following equations will be used:

$$A_i = K_0 Q_i (\chi/Q)$$

$$\text{and } \sum_{i=1}^n \frac{A_i}{ECL_i} \leq 1$$

Where:

A_i = Concentration of radionuclide (I) at the unrestricted area boundary

K_0 = Constant of unit conversion. (1.0E-6 m³/cc)

ECL_i = Effluent concentration limit (10 CFR Part 20, Appendix B, Table 2, Column 1 value for radionuclide(I))

Q_i = The release rate of radionuclide (I) in airborne effluents from all vent releases (in $\mu\text{Ci}/\text{sec.}$)

(χ/Q) = Annual Average Dispersion Factor at the Unrestricted Area Boundary from Part II, Table 4, of the Off-Site Dose Calculation Manual.

2.2.3 As appropriate, simultaneous releases from all release pathways will be considered in evaluating compliance with the release rate limits of 10 CFR Part 20. Historical annual average dispersion parameters, as presented in Table 4, may be used for evaluating the airborne effluent dose rate.

3.0 RADIOACTIVE EFFLUENT DOSE CALCULATIONS

3.1 Liquid Effluent Dose Calculations

3.1.1 Three pathways for human exposure to liquid releases from FCS to the Missouri River exists: 1) fish, 2) drinking water, and 3) Shoreline deposition. Fish are considered to be taken from the vicinity of the facility discharge. The drinking water for Omaha is located 19 miles downstream from FCS. The dilution factors for these pathways are derived from the Revised Environmental Report for FCS, (1974), (page 4-29 and 4-31). This report states that during Low-Low river conditions, the concentration at Omaha's water intake will be $\leq 14\%$ of the concentration at discharge from FCS and will average 3%. This equates to a dilution factor of 7.14, which is used to calculate the maximum dose to an individual from liquid pathways and a dilution factor of 33.33, for calculating the average dose. All pathways combine to give the dose to an individual in unrestricted areas.

3.1.2 10 CFR Part 50, Appendix I restricts the dose to individuals in the unrestricted areas from radioactive materials in liquid effluents from the Fort Calhoun Station to the following limits:

- during any calendar quarter
 - ≤ 1.5 mrem to total body
 - ≤ 5.0 mrem to any organ

and

- during any calendar year
 - ≤ 3.0 mrem to total body
 - ≤ 10.0 mrem to any organ

The following calculational methods shall be used for determining the dose or dose commitment from liquid effluents.

3.1.3 Doses from Liquid Effluent Pathways

A. Potable Water

$$R_{apj} = 1100 \frac{U_{ap} M_p}{F} \sum_{i=1}^n Q_i D_{aipj} \exp(-\lambda_i t_p)$$

Where:

R_{apj} = is the total annual dose to organ(j) of individuals of age group (a) from all of the radionuclides (I) in pathway (p), in mrem/yr.

U_{ap} = is a usage factor that specifies the intake rate for an individual of age group (a) associated with pathway (p), in ℓ /yr. (Table 6)

M_p = is the mixing ratio (reciprocal of the dilution factor) at the point of withdrawal of drinking water, dimensionless. (Table 17)

F = is the flow rate of the liquid effluent, in ft^3/sec .

Q_i = is the annual release rate of radionuclide (I), in Ci/yr.

D_{aipj} = is the dose factor specific to a given age group (a), radionuclide (I), pathway (p), and organ (j) which can be used to calculate the radiation dose from an intake of a radionuclide, in mrem/pCi. (Tables 13-16)

λ_i = is the radiological decay constant of radionuclide (I), in hr^{-1} .

t_p = is the average transit time required for radionuclides to reach the point of exposure. For internal dose, t_p is the total time elapsed between release of the radionuclides and ingestion of water, in hours. (Table 17)

1100 = Constant ($\text{pCi} \cdot \text{yr} \cdot \text{ft}^3/\text{Ci} \cdot \text{sec} \cdot \text{L}$)

3.1.3 (continued)

B. Aquatic Foods

$$R_{apj} = 1100 \frac{U_{ap} M_p}{F} \sum_{i=1}^n Q_i B_{ip} D_{aipj} \exp(-\lambda_i t_p)$$

Where:

- R_{apj} = is the total annual dose to organ (j) of individuals of age group (a) from all of the radionuclides (I) in pathway (p), in mrem/yr.
- U_{ap} = is a usage factor that specifies the intake rate for an individual of age group (a) associated with pathway (p), in kg/yr. (Table 6)
- M_p = is the mixing ratio (reciprocal of the dilution factor) at the point of harvest of aquatic food, dimensionless. (Table 17)
- F = is the flow rate of the liquid effluent, in ft³/sec.
- Q_i = is the annual release rate of radionuclide (I), in Ci/yr.
- B_{ip} = is the equilibrium bioaccumulation factor for radionuclide (I) in pathway (p) expressed as the ratio of the concentration in biota (in pCi/kg) to the radionuclide concentration in water (in pCi/liter), in (pCi/kg)/(pCi/liter). (Table 3)
- D_{aipj} = is the dose factor specific to a given age group (a), radionuclide (I), pathway (p), and organ (j), which can be used to calculate the radiation dose from an intake of a radionuclide, in mrem/pCi. (Tables 13-16)
- λ_i = is the radiological decay constant of radionuclide (I), in hr⁻¹.
- t_p = is the average transit time required for radionuclides to reach the point of exposure. For internal dose, t_p is the total time elapsed between release of the radionuclides and ingestion of food, in hours. (Table 17)
- 1100 = Constant (pCi * yr * ft³/Ci * sec * L)

3.1.3 (continued)

C. Shoreline Deposits

$$R_{apj} = 110,000 \frac{U_{ap} M_p W}{F} \sum_{i=1}^n Q_i T_{ip} D_{aipj} [\exp(-\lambda_i t_p)] [1 - \exp(-\lambda_i t_b)]$$

Where:

- R_{apj} = is the total annual dose to organ (j) of individuals of age group (a) from all of the radionuclides (I) in pathway (p), in mrem/yr.
- U_{ap} = is a usage factor that specifies the exposure time for an individual of age group (a) associated with pathway (p), in hr/yr. (Table 6)
- M_p = is the mixing ratio (reciprocal of the dilution factor) at the point of exposure, dimensionless. (Table 17)
- W = is the shore-width factor, dimensionless. (Table 17)
- F = is the flow rate of the liquid effluent, in ft³/sec.
- Q_i = is the annual release rate of radionuclide (I), in Ci/yr.
- T_{ip} = is the radioactive half life of radionuclide (I), in days.
- D_{aipj} = is the dose factor specific radionuclide (I) which can be used to calculate the radiation dose from exposure to a given concentration of a radionuclide in sediment, expressed as a ratio of the dose rate (in mrem/hr) and the real radionuclide concentration (in pCi/m²). (Table 8)
- λ_i = is the radiological decay constant of radionuclide (I), in hr⁻¹.
- t_p = is the average transit time required for radionuclides to reach the point of exposure, in hours. (Table 17)
- t_b = is the period of time for which sediment or soil is exposed to the contaminated water, in hours. (Table 17)

$$110,000 = \text{Constant } [(100 * \text{pCi} * \text{yr} * \text{ft}^3) / (\text{Ci} * \text{sec} * \text{L})]$$

3.2 Airborne Effluent Dose Calculations

3.2.1 Radioiodine, Tritium, and Particulates

10 CFR Part 50, Appendix I, restricts the dose to individuals in the unrestricted areas from radioactive materials in gaseous airborne from the Fort Calhoun Station to:

- During any calendar quarter
 ≤ 7.5 mrem to any organ

and

- During any calendar year
 ≤ 15 mrem to any organ

The dose to an individual from radioiodines, radioactive materials in particulate form, and radionuclides other than noble gases with half-lives greater than 8 days in airborne effluents released to unrestricted areas should be determined by the following expressions:

i	NOTE	i
	In all cases, for releases of tritium, use the dispersion parameter for inhalation (χ/Q).	

A. Annual Organ Dose from External Irradiation from Radioactivity Deposited on the Ground Plane

The ground plane concentration of radionuclide (I) at distance r , in the sector at angle θ , with respect to the release point, may be determined by:

$$C_i^G(r, \theta) = \frac{[1.0 \times 10^{12}][\delta_i(r, \theta)Q_i]}{\lambda_i} [1 - \exp(-\lambda_i t_b)]$$

Where:

C_i^G = is the ground plane concentration of the radionuclide (I) at distance r , in the sector at angle θ , from the release point, in pCi/m².

Q_i = is the annual release rate of radionuclide (I) to the atmosphere, in Ci/yr.

t_b = is the time period over which the accumulation is evaluated, which is assumed to be 20 years (mid-point of plant operating life). (Table 17)

$\delta_i(r, \theta)$ = is the annual average relative deposition of radionuclide (I) at distance r , in the sector at angle θ , considering depletion of the plume by deposition during transport, in m⁻². Table 4

λ_i = is the radiological decay constant for radionuclide (I), in yr⁻¹.

1.0×10^{12} = is the number of pCi/Ci

The annual organ dose is then calculated using the following equation:

$$D_i^G(r, \theta) = 8760 S_f \sum_{i=1}^n C_i^G(r, \theta) DFG_{ij}$$

Where:

- $C_i^G(r, \theta)$ = is the ground plane concentration of radionuclide (i) at distance r, in the sector at angle θ , in pCi/m².
- DFG_{ij} = is the open field ground plane dose conversion factor for organ (j) from radionuclide (i), in mrem-m²/pCi-hr. (Table 8)
- $D_j^G(r, \theta)$ = is the annual dose to the organ (j) at distance r, in the sector at angle θ , in mrem/yr.
- S_f = is the shielding factor that accounts for the dose reduction due to shielding provided by residential structures during occupancy, dimensionless. (Table 17)
- 8760 = is the number of hours in a year

B. Annual Dose from Inhalation of Radionuclides in Air

The annual average airborne concentration of radionuclide (i) at distance r, in the sector at angle θ , with respect to the release point, may be determined as:

$$X_i(r, \theta) = 3.17 \times 10^4 Q_i [\chi/Q]^D(r, \theta)$$

Where:

- Q_i = is the annual release rate of radionuclide (i) to the atmosphere, in Ci/yr.
- $\chi_i(r, \theta)$ = is the annual average ground-level concentration of radionuclide (i) in air at distance r, in the sector at angle θ , in pCi/m³.
- $[\chi/Q]^D(r, \theta)$ = is the annual average atmosphere dispersion factor, in sec/m³ (see Reg Guide 1.111). This includes depletion (for radioiodines and particulates) and radiological decay of the plume. (Table 4)
- 3.17×10^4 = is the number of pCi/Ci divided by the number of sec/yr.

The annual dose associated with inhalation of all radionuclides to organ (j) of an individual in age group (a), is then:

$$D_{ja}^A(r, \theta) = R_a \sum_{i=1}^n X_i(r, \theta) DFA_{ija}$$

Where:

- $D_{ja}^A(r, \theta)$ = is the annual dose to organ (j) of an individual in the age group (a) at distance r, in the sector at angle θ , due to inhalation, in mrem/yr.
- R_a = is the annual air intake for individuals in the age group (a), in m^3/yr . (Table 6)
- $X_i(r, \theta)$ = is the annual average ground-level concentration of radionuclide (i) in air at distance r, in the sector at angle θ , in pCi/ m^3 .
- DFA_{ija} = is the inhalation dose factor for radionuclide (i), organ (j), and age group (a), in mrem/pCi. (Tables 9-12)

3.2.2 Concentrations of Radionuclides in Foods and Vegetation from Atmospheric Releases

A. Parameters for Calculating Concentrations in Forage, Produce, and Leafy Vegetables, excluding Tritium

$$C_i^V(r, \theta) = d_i(r, \theta) \left[\frac{r[1 - \exp(-\lambda_{Ei}t_e)]}{Y_v\lambda_{Ei}} + \frac{B_{iv}[1 - \exp(-\lambda_i t_b)]}{P\lambda_i} \right] \exp(-\lambda_i t_h)$$

Where:

- $C_i^V(r, \theta)$ = is the concentration of radionuclide (i) in and on vegetation at distance r, in the sector at angle θ , in pCi/kg.
- $d_i(r, \theta)$ = is the deposition rate of radionuclide (i) at distance r, in the sector at angle θ , in pCi/m² hr.
- r = is the fraction of deposited activity retained on crops, dimensionless. (Table 17)
- λ_{Ei} = is the effective removal rate constant for radionuclide (i) from crops, in hr⁻¹.
 $\lambda_{Ei} = \lambda_i + \lambda_w$
 $\lambda_w = 0.0021/\text{hr}$. (Table 17)
- t_e = is the time period that crops are exposed to contamination during the growing season, in hours. (Table 17)
- Y_v = is the agricultural productivity (yield) in kg (wet weight)/m². (Table 17)
- B_{iv} = is the concentration factor for uptake of radionuclide (i) from soil by edible parts of crops, in pCi/ kg (wet weight) per pCi/kg dry soil. (Table 5)
- λ_i = is the radiological decay constant of radionuclide (i), in hr⁻¹
- t_b = is the period of time for which sediment or soil is exposed to the contaminated water, in hours (mid-point of plant life). (Table 17)
- P = is the effective "surface density" for soil, in kg (dry soil)/m². (Table 17)
- t_h = is the holdup time that represents the time interval between harvest and consumption of the food, in hours. (Table 17)

Different values for the parameters t_e , Y_v , and t_h , may be used to allow the use of the Equation for different purposes: estimating concentrations in produce consumed by man; in leafy vegetables consumed by man; in forage consumed directly as pasture grass by dairy cows, beef cattle, or goats; and in forage consumed as stored feed by dairy cows, beef cattle or goats. See Table 17.

The deposition rate from the plume is defined by (Reg. Guide 1.109, Rev. 1, Page 1.109-26, Equa. C-6):

$$d_i(r, \theta) = 1.1 \times 10^8 \delta_i(r, \theta) Q_i$$

Where:

$d_i(r, \theta)$ = is the deposition rate of radionuclide (i).

$\delta_i(r, \theta)$ = is the relative deposition of radionuclide (i), considering depletion and decay, in m^{-2} (see Reg Guide 1.111). (Table 4)

1.1×10^8 = is the number of pCi/Ci (10^{12}) divided by the number of hours per year (8760).

Q_i = is the annual release rate of radionuclide (i) to the atmosphere, in Ci/yr.

- B. For radioiodines, the model considers only the elemental fraction of the effluent:

$$d_i(r, \theta) = 3.3 \times 10^7 \delta_i(r, \theta) Q_i$$

Where:

- $d_i(r, \theta)$ = The deposition rate of radioiodine (i).
- 3.3×10^7 = The number of pCi/Ci (1012) divided by the number of hours per year (8760), then multiplied by the amount of radioiodine emissions considered to be elemental (0.5).
- $\delta_i(r, \theta)$ = The relative deposition of radioiodine (i), considering depletion and decay, in m⁻². (Table 4)
- Q_i = The total (elemental and nonelemental) radioiodine (i) emission rate.

- C. Parameters for Calculating the Concentration of Radionuclide (i) in the Animal's Feed (Milk Cow, Beef Cow, and Goat)

$$C_i^V(r, \theta) = f_p f_s C_i^P(r, \theta) + (1 - f_p) C_i^S(r, \theta) + f_p (1 - f_s) C_i^S(r, \theta)$$

Where:

- $C_i^V(r, \theta)$ = is the concentration of radionuclide (i) in the animal's feed, in pCi/kg.
- $C_i^P(r, \theta)$ = is the concentration of radionuclide (i) on pasture grass (calculated using Equation 3.2.3A with $t_h=0$), in pCi/kg.
- $C_i^S(r, \theta)$ = is the concentration of radionuclide (i) in stored feeds (calculated using Equation 3.2.3A with $t_h=90$ days), in pCi/kg.
- f_p = is the fraction of the year that animals graze on pasture. (Table 17)
- f_s = is the fraction of daily feed that is pasture grass while the animal grazes on pasture. (Table 17)

3.2.3 Parameters for Calculating Radionuclide Concentration in Cow and Goat Milk

$$C_i^M(r, \theta) = F_m C_i^V(r, \theta) Q_F \exp(-\lambda_i t_f)$$

Where:

$C_i^M(r, \theta)$ = is the concentration of radionuclide (i) in milk, in pCi/liter.

$C_i^V(r, \theta)$ = is the concentration of radionuclide (i) in the animal's feed, in pCi/kg.

F_m = is the average fraction of the animal's daily intake of radionuclide (i) which appears in each liter of milk, in days/liter. (Table 5)

Q_F = is the amount of feed consumed by the animal per day, in kg/day. (Table 7)

t_f = is the average transport time of the radionuclide (i) from the feed to the milk and to the receptor (a value of 2 days is assumed). (Table 17)

λ_i = is the radiological decay constant of radionuclide (i), in days⁻¹.

3.2.4 Parameters for Calculating Radionuclide Concentration in Cow Meat, excluding Tritium

$$C_i^F(r, \theta) = F_f C_i^V(r, \theta) Q_F \exp(-\lambda_i t_s)$$

Where:

$C_i^F(r, \theta)$ = is the concentration of radionuclide (i) in meat, in pCi/liter.

$C_i^V(r, \theta)$ = is the concentration of radionuclide (i) in the animal's feed, in pCi/kg.

Q_F = is the amount of feed consumed by the animal per day, in kg/day. (Table 7)

F_f = is the average fraction of the animal's daily intake of radionuclide (i) which appears in each kilogram of flesh, in days/kilogram. (Table 5)

t_s = is the average time from slaughter to consumption. (Table 17)

3.2.5 Parameters for Calculating Tritium Concentrations in Vegetation

The concentration of tritium in vegetation is calculated from its concentration in the air surrounding the vegetation.

$$C_T^V(r, \theta) = 3.17 \times 10^7 Q_T \frac{[\chi/Q](r, \theta)(0.75)(0.5)}{H} = 1.2 \times 10^7 Q_T \frac{[\chi/Q](r, \theta)}{H}$$

Where:

$C_T^V(r, \theta)$ = is the concentration of tritium in vegetation grown at distance r, in the sector at angle θ , in pCi/kg.

H = is the absolute humidity of the atmosphere at distance r, in the sector at angle θ , in g/m³. H=8 gm/kg.

Q_T = is the annual release rate of tritium, in Ci/yr.

$[\chi/Q](r, \theta)$ = is the atmospheric dispersion factor, in sec/m³. (Table 4)

0.5 = is the ratio of tritium concentration in facility water to tritium concentration in atmospheric water, dimensionless.

0.75 = is the fraction of total facility mass that is water, dimensionless.

3.2.6 Annual Dose from Atmospherically Released Radionuclides in Foods

- A. The total annual dose to organ (j) of an individual in age group (a) resulting from ingestion of all radionuclides in produce, milk, and leafy vegetables is given by:

$$D_{ja}^D(r, \theta) = \sum_i DFI_{ija} [U_a^V f_g C_i^V(r, \theta) + U_a^M C_i^M(r, \theta) + U_a^F C_i^F(r, \theta) + U_a^L f_\ell C_i^L(r, \theta)]$$

Where:

- $D_{ja}^D(r, \theta)$ = is the annual dose to organ (j) of an individual in age group (a) from dietary intake of atmospherically released radionuclides, in mrem/yr.
- DFI_{ija} = is the dose conversion factor for the ingestion of radionuclide (i), organ (j), and age group (a), in mrem/pCi. Tables 13-16.
- U_a^V = are the ingestion rates of produce (non-leafy vegetables, fruits, and grains), respectively for individuals in age group (a). (Table 6)
- U_a^M = is the ingestion rate of cow milk for individuals in age group (a), in P/yr. (Table 6)
- U_a^F = is the ingestion rate of meat for individuals in age group (a), in kg/yr. (Table 6)
- U_a^L = are the ingestion rates of leafy vegetables for individuals in age group (a), in kg/yr. (Table 6)
- $C_i^V(r, \theta)$ = is the concentration of radionuclide (i) in the animal's feed, in pCi/kg.
- $C_i^M(r, \theta)$ = is the concentration of radionuclide (i) in milk, in pCi/liter.
- $C_i^F(r, \theta)$ = is the concentration of radionuclide (i) in meat, in pCi/liter.
- $C_i^L(r, \theta)$ = is the concentration of radionuclide (i) in and on leafy vegetation, in pCi/kg.
- f_g = Fraction of ingested produce grown in garden of interest (Table 17)
- f_ℓ = Fraction of leafy vegetables grown in garden of interest (Table 17)

B. Calculating the Ingested Dose from Leafy and Non-Leafy (produce) Vegetation for Radionuclide (i) to Each Organ (j) and Age Group (a)

$$D_{ja}^D(r, \theta) = DFI_{ija} [U_a^L f_\ell C_i^L(r, \theta) + U_a^V f_g C_i^V(r, \theta)]$$

Where:

- $D_{ja}^D(r, \theta)$ = is the annual dose from the ingestion of radionuclide (i) to organ (j) of an individual in age group (a) from dietary intake of atmospherically released radionuclides in vegetation, in mrem/yr.
- DFI_{ija} = is the dose conversion factor for the ingestion of radionuclide (i), organ (j), and age group (a), in mrem/pci. Tables 13-16
- U_a^L, U_a^V = are the ingestion rates of leafy vegetables and produce (non-leafy vegetables, fruits, and grains), for individuals in age group (a), in kg/yr. (Table 6)
- C_i^L = is the concentration of radionuclide (i) in and on leafy vegetation, in pCi/kg.
- C_i^V = is the concentration of radionuclide (i) in and on produce, in pCi/kg.
- f_g = Fraction of ingested produce grown in garden of interest (Table 17)
- f_ℓ = Fraction of leafy vegetables grown in garden of interest (Table 17)

C. Calculation Determining the Ingested Dose from Cow Milk for Radionuclide (i), Organ (j), and Age Group (a)

$$D_{ja}^D(r, \theta) = DFI_{ija} [U_a^M C_i^M(r, \theta)]$$

Where:

- $D_{ja}^D(r, \theta)$ = is the annual dose from the ingestion of radionuclide (i), organ (j) of an individual in age group (a) from dietary intake of atmospherically released radionuclides in cow milk, in mrem/yr.
- DFI_{ija} = is the dose conversion factor for the ingestion of radionuclide (i), organ (j), and age group (a), in mrem/pCi. (Tables 13-16)
- U_a^M = is the ingestion rate of cow milk for individuals in age group (a), in P/yr. (Table 6)
- C_i^M = is the radionuclide concentration in cow milk, in pCi/kg.
Equation 3.2.4

D. Calculation Determining the Ingested Dose from Meat for Radionuclide (i) to Organ (j) and Age Group (a)

$$D_{ja}^D(r, \theta) = DFI_{ija} [U_a^F C_i^F(r, \theta)]$$

Where:

- $D_{ja}^D(r, \theta)$ = is the annual dose from the ingestion of radionuclide (i), organ (j) of an individual in age group (a) from dietary intake of atmospherically released radionuclides in meat, in mrem/yr.
- DFI_{ija} = is the dose conversion factor for the ingestion of radionuclide (i), organ (j), and age group (a), in mrem/pCi. (Tables 13-16)
- U_a^F = is the ingestion rate of meat for individuals in age group (a), in kg/yr. (Table 6)
- C_i^F = is the radionuclide (i) concentration in meat, in pCi/kg.

4.0 LOWER LIMIT OF DETECTION (LLD)

4.1 The lower limit of detection (LLD) for liquid and airborne effluent discharges and environmental samples referenced in Part I, Tables 4.1, 4.2 and 5.3, of the Off-Site Dose Calculation Manual, is defined as the smallest concentration of radioactive material in a sample that will yield a net count, above system background, that will be detected with 95 percent probability with only 5 percent probability of falsely concluding that a blank observation represents a "real" signal.

4.2 For a particular measurement system, which may include radiochemical separation:

$$LLD = \frac{4.66 * S_b}{E * V * D * Y * \exp(-\lambda\Delta t)}$$

Where:

LLD = the lower limit of detection as defined above, in either picoCuries or microCuries, per unit mass or volume as a function of the value of D

S_b = the standard deviation of the background counting rate or of the counting rate of a blank sample, as appropriate, as counts per minute

E = the counting efficiency, as counts per disintegration

V = the sample size in units of mass or volume

D = 2.22E+06 of disintegrations per minute per microCurie or 2.22 disintegrations per minute per picoCurie

Y = the fractional radiochemical yield, when applicable

λ = the radioactive decay constant for the particular radionuclide

Δt = the elapsed time between the midpoint of sample collection and time of counting

Appropriate values of E, V, Y, and Δt should be used in the calculation.

4.3 It should be recognized that the LLD is defined as an A Priori limit representing the capability of a measurement system and not as a limit for a particular measurement.

4.4 LLD verifications will be performed on a periodic basis. This determination is to ensure that the counting system is able to detect levels of radiation at the LLD values for the specific type of analysis required. They will be performed with a blank (non-radioactive) sample in the same counting geometry as the actual sample.

Table 2 - Deleted

Table 3 - Bioaccumulation Factors
(pCi/kg per pCi/liter)

FRESHWATER

Element	Fish	Invertebrate
H	9.0E-01	9.0E-01
C	4.6E+03	9.1E+03
Na	1.0E+02	2.0E+02
P	1.0E+05	2.0E+04
Cr	2.0E+02	2.0E+03
Mn	4.0E+02	9.0E+04
Fe	1.0E+02	3.2E+03
Co	5.0E+01	2.0E+02
Ni	1.0E+02	1.0E+02
Cu	5.0E+01	4.0E+02
Zn	2.0E+03	1.0E+04
Br	4.2E+02	3.3E+02
Rb	2.0E+03	1.0E+03
Sr	3.0E+01	1.0E+02
Y	2.5E+01	1.0E+03
Zr	3.3E+00	6.7E+00
Nb	3.0E+04	1.0E+02
Mo	1.0E+01	1.0E+01
Tc	1.5E+01	5.0E+00
Ru	1.0E+01	3.0E+02
Rh	1.0E+01	3.0E+02
Te	4.0E+02	6.1E+03
I	1.5E+01	5.0E+00
Cs	2.0E+03	1.0E+03
Ba	4.0E+00	2.0E+02
La	2.5E+01	1.0E+03
Ce	1.0E+00	1.0E+03
Pr	2.5E+01	1.0E+03
Nd	2.5E+01	1.0E+03
W	1.2E+03	1.0E+01
Np	1.0E+01	4.0E+02

Table 4 - Highest Potential Exposure Pathways for Estimating Dose

Exposure Pathway	Location ^B	Direction ^B	Distance from Containment (miles) ^B	X/Q ^A { $\chi/Q(r,\theta)$ } (sec/m ³)	D/Q ^A { $\delta(r,\theta)$ } (m ⁻²)
Direct Exposure	Site Boundary	ESE	0.29	6.30E-05	N/A
Inhalation	Site Boundary	ESE	0.29	6.30E-05	N/A
Ingestion	Residence	SSE	0.65	N/A	6.00E-08

- A. These values are used for calculating quarterly dose estimates during the annual reporting period and are based on a 5 year historical average. Ten percent (10%) will be added to these values for dose estimates during the reporting periods. These values are periodically re-evaluated by comparing the X/Q values reported by NOAA in similar locations.
- B. The location is subject to change based on an annual evaluation and is utilized only for ingestion exposure pathway dose estimates. This location may differ from the highest ingestion exposure pathway for offsite air monitoring locations as determined by the Land Use Survey performed biennially in accordance with Part 1, Section 7.3.2, of the Off-Site Dose Calculation Manual.

Table 5 - Stable Element Transfer Data

Element	B_{iv} Veg./Soil	F_m (cow) Milk (d/l)	F_m (goat) Milk (d/l)	F_f Meat (d/kg)
H	4.8E+00	1.0E-02	1.7E-01	1.2E-02
C	5.5E+00	1.2E-02	1.0E-01	3.1E-02
Na	5.2E-02	4.0E-02	-----	3.0E-02
P	1.1E+00	2.5E-02	2.5E-01	4.6E-02
Cr	2.5E-04	2.2E-03	-----	2.4E-03
Mn	2.9E-02	2.5E-04		8.0E-04
Fe	6.6E-04	1.2E-03	1.3E-04	4.0E-02
Co	9.4E-03	1.0E-03	-----	1.3E-02
Ni	1.9E-02	6.7E-03	-----	5.3E-02
Cu	1.2E-01	1.4E-02	1.3E-02	8.0E-03
Zn	4.0E-01	3.9E-02	-----	3.0E-02
Rb	1.3E-01	3.0E-02	-----	3.1E-02
Sr	1.7E-02	8.0E-04	1.4E-02	6.0E-04
Y	2.6E-03	1.0E-05	-----	4.6E-03
Zr	1.7E-04	5.0E-06	-----	3.4E-02
Nb	9.4E-03	2.5E-03	-----	2.8E-01
Mo	1.2E-01	7.5E-03	-----	8.0E-03
Tc	2.5E-01	2.5E-02	-----	4.0E-01
Ru	5.0E-02	1.0E-06	-----	4.0E-01
Rh	1.3E+1	1.0E-02	-----	1.5E-03
Ag	1.5E-01	5.0E-02	-----	1.7E-02
Sb	1.1E-02	1.5E-03	-----	4.0E-03
Te	1.3E+00	1.0E-03	-----	7.7E-02
I	2.0E-02	6.0E-03	6.0E-02	2.9E-03
Cs	1.0E-02	1.2E-02	3.0E-01	4.0E-03
Ba	5.0E-03	4.0E-04	-----	3.2E-03
La	2.5E-03	5.0E-06	-----	2.0E-04
Ce	2.5E-03	1.0E-04	-----	1.2E-03
Pr	2.5E-03	5.0E-06	-----	4.7E-03
Nd	2.4E-03	5.0E-06	-----	3.3E-03
W	1.8E-02	5.0E-04	-----	1.3E-03
Pu	2.5E-04	2.0E-06	-----	1.4E-05
Np	2.5E-03	5.0E-06	-----	2.0E-04
Am	2.5E-04	5.0E-06	-----	2.0E-04
Cm	2.5E-03	5.0E-06	-----	2.0E-04

Table 6 - Recommended Values for U_{ap} to Be Used for the Maximum Exposed Individual in Lieu of Site Specific Data

Pathway	Infant	Child	Teen	Adult
Fruits, vegetables, & grain (kg/yr)	---	520	630	520
Leafy vegetables (kg/yr)	---	26	42	64
Milk (P/yr)	330	330	400	310
Meat & poultry (kg/yr)	---	41	65	110
Fish (fresh or salt)(kg/yr)	---	6.9	16	21
Other Seafood (kg/yr)	---	1.7	3.8	5
Drinking water (P/yr)	330	510	510	730
Shoreline recreation (hr/yr)	---	14	67	12
Inhalation (m ³ /yr)	1400	3700	8000	8000

Table 7 - Animal Consumption Rates

Animal	Q_F Feed or Forage [Kg/day (wet weigh)]	Q_{AW} Water (ℓ/day)
Milk Cow	50	60
Beef Cattle	50	50
Goats	6	8

Table 8 - External Dose Factors for Standing on Contaminated Ground
(mrem/hr per pCi/m²)

Element	Total Body	Skin
H-3	---	---
C-14	---	---
Na-24	2.50E-08	2.90E-08
P-32	---	---
Cr-51	2.20E-10	2.60E-10
Mn-54	5.80E-09	6.80E-09
Mn-56	1.10E-08	1.30E-08
Fe-55	---	---
Fe-59	8.00E-09	9.40E-09
Co-58	7.00E-09	8.20E-09
Co-60	1.70E-08	2.00E-08
Ni-59	---	---
Ni-63	---	---
Nr-65	3.70E-09	4.30E-09
Cu-64	1.50E-09	1.70E-09
Zn-65	4.00E-09	4.60E-09
Zn-69	---	---
Br-83	6.40E-11	9.30E-11
Br-84	1.20E-08	1.40E-08
Br-85	---	---
Rb-86	6.30E-10	7.20E-10
Rb-88	3.50E-09	4.00E-09
Rb-89	1.50E-08	1.80E-08
Sr-89	5.60E-13	6.50E-13
Sr-91	7.10E-09	8.30E-09
Sr-92	9.00E-09	1.00E-08
Y-90	2.20E-12	2.60E-12
Y-91M	3.80E-09	4.40E-09
Y-91	2.40E-11	2.70E-11
Y-92	1.60E-09	1.90E-09
Y-93	5.70E-10	7.80E-10
Zr-95	5.00E-09	5.80E-09
Zr-97	5.50E-09	6.40E-09
Nb-95	5.10E-09	6.00E-09
Mo-99	1.90E-09	2.20E-09
Tc-99M	9.60E-10	1.10E-09
Tc-101	2.70E-09	3.00E-09

Table 8 - External Dose Factors for Standing on Contaminated Ground
(mrem/hr per pCi/m²)

Element	Total Body	Skin
Ru-103	3.60E-09	4.20E-09
Ru-105	4.50E-09	5.10E-09
Ru-106	1.50E-09	1.80E-09
Ag-110M	1.80E-08	2.10E-08
Sb-124	1.30E-08	1.50E-08
Sb-125	3.10E-09	3.50E-09
Te-125M	3.50E-11	4.80E-11
Te-127M	1.10E-12	1.30E-12
Te-127	1.00E-11	1.10E-11
Te-129M	7.70E-10	9.00E-10
Te-129	7.10E-10	8.40E-10
Te-131M	8.40E-09	9.90E-09
Te-131	2.20E-09	2.60E-06
Te-132	1.70E-09	2.00E-09
I-130	1.40E-08	1.70E-08
I-131	2.80E-09	3.40E-09
I-132	1.70E-08	2.00E-08
I-133	3.70E-09	4.50E-09
I-134	1.60E-08	1.90E-08
I-135	1.20E-08	1.40E-08
Cs-134	1.20E-08	1.40E-08
Cs-136	1.50E-08	1.70E-08
Cs-137	4.20E-09	4.90E-09
Cs-138	2.10E-08	2.40E-08
Ba-139	2.40E-09	2.70E-09
Ba-140	2.10E-09	2.40E-09
Ba-141	4.30E-09	4.90E-09
Ba-142	7.90E-09	9.00E-09
La-140	1.50E-08	1.70E-08
La-142	1.50E-08	1.80E-08
Ce-141	5.50E-10	6.20E-10
Ce-143	2.20E-09	2.50E-09
Ce-144	3.20E-10	3.70E-10
Pr-143	---	---
Pr-144	2.00E-10	2.30E-10
Nd-147	1.00E-09	1.20E-09
W-187	3.10E-09	3.60E-09

Table 8 - External Dose Factors for Standing on Contaminated Ground
(mrem/hr per pCi/m²)

Element	Total Body	Skin
Pu-238	1.30E-12	1.80E-11
Pu-239	7.90E-13	7.70E-12
Pu-240	1.30E-12	1.80E-11
Pu-241	4.60E-12	6.80E-12
Np-239	9.50E-10	1.10E-09
Am-241	1.80E-10	2.60E-10
Cm-242	5.50E-12	2.30E-11
Cm-243	2.30E-09	2.90E-09
Cm-244	2.90E-12	1.80E-11

Table 9 - Inhalation Dose Factors for Adult
(mrem per pCi Inhaled)

Nuclide	Bone	Liver	T. Body	Thyroid	Kidney	Lung	GI-LLI
H-3	---	8.98E-08	8.98E-08	8.98E-08	8.98E-08	8.98E-08	8.98E-08
C-14	2.27E-06	4.26E-07	4.26E-07	4.26E-07	4.26E-07	4.26E-07	4.26E-07
Na-24	1.28E-06	1.28E-06	1.28E-06	1.28E-06	1.28E-06	1.28E-06	1.28E-06
P-32	1.65E-04	9.64E-06	6.26E-06	---	---	---	1.08E-05
Cr-51	---	---	1.25E-08	7.44E-09	2.85E-09	1.80E-06	4.15E-07
Mn-54	---	4.95E-06	7.87E-07	---	1.23E-06	1.75E-04	9.67E-06
Mn-56	---	1.55E-10	2.29E-11	---	1.63E-10	1.18E-06	2.53E-06
Fe-55	3.07E-06	2.12E-06	4.93E-07	---	---	9.01E-06	7.54E-07
Fe-59	1.47E-06	3.47E-06	1.32E-06	---	---	1.27E-04	2.35E-05
Co-58	---	1.98E-07	2.59E-07	---	---	1.16E-04	1.33E-05
Co-60	---	1.44E-06	1.85E-06	---	---	7.46E-04	3.56E-05
Ni-59	4.06E-06	1.46E-06	6.77E-07	---	---	8.20E-06	6.11E-07
Ni-63	5.40E-05	3.93E-06	1.81E-06	---	---	2.23E-05	1.67E-06
Ni-65	1.92E-10	2.62E-11	1.14E-11	---	---	7.00E-07	1.54E-06
Cu-64	---	1.83E-10	7.69E-11	---	5.78E-10	8.48E-07	6.12E-06
Zn-65	4.05E-06	1.29E-05	5.82E-06	---	8.62E-06	1.08E-04	6.68E-06
Zn-69	4.23E-12	8.14E-12	5.65E-13	---	5.27E-12	1.15E-07	2.04E-09
Br-83	---	---	3.01E-08	---	---	---	2.90E-08
Br-84	---	---	3.91E-08	---	---	---	2.05E-13
Br-85	---	---	1.60E-09	---	---	---	---
Rb-86	---	1.69E-05	7.37E-06	---	---	---	2.08E-06
Rb-88	---	4.84E-08	2.41E-08	---	---	---	4.18E-19
Rb-89	---	3.20E-08	2.12E-08	---	---	---	1.16E-21
Sr-89	3.80E-05	---	1.09E-06	---	---	1.75E-04	4.37E-05
Sr-90	3.59E-03	---	7.21E-05	---	---	1.20E-03	9.02E-05
Sr-91	7.74E-09	---	3.13E-10	---	---	4.56E-06	2.39E-05
Sr-92	8.43E-10	---	3.64E-11	---	---	2.06E-06	5.38E-06
Y-90	2.61E-07	---	7.01E-09	---	---	2.12E-05	6.32E-05
Y-91M	3.26E-11	---	1.27E-12	---	---	2.40E-07	1.66E-10
Y-91	5.78E-05	---	1.55E-06	---	---	2.13E-04	4.81E-05
Y-92	1.29E-09	---	3.77E-11	---	---	1.96E-06	9.19E-06
Y-93	1.18E-08	---	3.26E-10	---	---	6.06E-06	5.27E-05
Zr-95	1.34E-05	4.30E-06	2.91E-06	---	6.77E-06	2.21E-04	1.88E-05
Zr-97	1.21E-08	2.45E-09	1.13E-09	---	3.71E-09	9.84E-06	6.54E-05
Nb-95	1.76E-06	9.77E-07	5.26E-07	---	9.67E-07	6.31E-05	1.30E-05
Mo-99	---	1.51E-08	2.87E-09	---	3.64E-08	1.14E-05	3.10E-05
Tc-99M	1.29E-13	3.64E-13	4.63E-12	---	5.52E-12	9.55E-08	5.20E-07

Table 9 - Inhalation Dose Factors for Adult
(mrem per pCi Inhaled)

Nuclide	Bone	Liver	T. Body	Thyroid	Kidney	Lung	GI-LLI
Tc-101	5.22E-15	7.52E-15	7.38E-14	---	1.35E-13	4.99E-08	1.36E-21
Ru-103	1.91E-07	---	8.23E-08	---	7.29E-07	6.31E-05	1.38E-05
Ru-105	9.88E-11	---	3.89E-11	---	1.27E-10	1.37E-06	6.02E-06
Ru-106	8.64E-06	---	1.09E-06	---	1.67E-05	1.17E-03	1.14E-04
Ag-110M	1.35E-06	1.25E-06	7.43E-07	---	2.46E-06	5.79E-04	3.78E-05
Sb-124	3.90E-06	7.36E-08	1.55E-06	9.44E-09	---	3.10E-04	5.08E-05
Sb-125	6.67E-06	7.44E-08	1.58E-06	6.75E-09	---	2.18E-04	1.26E-05
Te-125M	4.27E-07	1.98E-07	5.84E-08	1.31E-07	1.55E-06	3.92E-05	8.83E-06
Te-127M	1.58E-06	7.21E-07	1.96E-07	4.11E-07	5.72E-06	1.20E-04	1.87E-05
Te-127	1.75E-10	8.03E-11	3.87E-11	1.32E-10	6.37E-10	8.14E-07	7.17E-06
Te-129M	1.22E-06	5.84E-07	1.98E-07	4.30E-07	4.57E-06	1.45E-04	4.79E-05
Te-129	6.22E-12	2.99E-12	1.55E-12	4.87E-12	2.34E-11	2.42E-07	1.96E-08
Te-131M	8.74E-09	5.45E-09	3.63E-09	6.88E-09	3.86E-08	1.82E-05	6.95E-05
Te-131	1.39E-12	7.44E-13	4.49E-13	1.17E-12	5.46E-12	1.74E-07	2.30E-09
Te-132	3.25E-08	2.69E-08	2.02E-08	2.37E-08	1.82E-07	3.60E-05	6.37E-05
I-130	5.72E-07	1.68E-06	6.60E-07	1.42E-04	2.61E-06	---	9.61E-07
I-131	3.15E-06	4.47E-06	2.56E-06	1.49E-03	7.66E-06	---	7.85E-07
I-132	1.45E-07	4.07E-07	1.45E-07	1.43E-05	6.48E-07	---	5.08E-08
I-133	1.08E-06	1.85E-06	5.65E-07	2.69E-04	3.23E-06	---	1.11E-06
I-134	8.05E-08	2.16E-07	7.69E-08	3.73E-06	3.44E-07	---	1.26E-10
I-135	3.35E-07	8.73E-07	3.21E-07	5.60E-05	1.39E-06	---	6.56E-07
Cs-134	4.66E-05	1.06E-04	9.10E-05	---	3.59E-05	1.22E-05	1.30E-06
Cs-136	4.88E-06	1.83E-05	1.38E-05	---	1.07E-05	1.50E-06	1.46E-06
Cs-137	5.98E-05	7.76E-05	5.35E-05	---	2.78E-05	9.40E-06	1.05E-06
Cs-138	4.14E-08	7.76E-08	4.05E-08	---	6.00E-08	6.07E-09	2.33E-13
Ba-139	1.17E-10	8.32E-14	3.42E-12	---	7.78E-14	4.70E-07	1.12E-07
Ba-140	4.88E-06	6.13E-09	3.21E-07	---	2.09E-09	1.59E-04	2.73E-05
Ba-141	1.25E-11	9.41E-15	4.20E-13	---	8.75E-15	2.42E-07	1.45E-17
Ba-142	3.29E-12	3.38E-15	2.07E-13	---	2.86E-15	1.49E-07	1.96E-26
La-140	4.30E-08	2.17E-08	5.73E-09	---	---	1.70E-05	5.73E-05
La-142	8.54E-11	3.88E-11	9.65E-12	---	---	7.91E-07	2.64E-07
Ce-141	2.49E-06	1.69E-06	1.91E-07	---	7.83E-07	4.52E-05	1.50E-05
Ce-143	2.33E-08	1.72E-08	1.91E-09	---	7.60E-09	9.97E-06	2.83E-05
Ce-144	4.29E-04	1.79E-04	2.30E-05	---	1.06E-04	9.72E-04	1.02E-04
Pr-143	1.17E-06	4.69E-07	5.80E-08	---	2.70E-07	3.51E-05	2.50E-05
Pr-144	3.76E-12	1.56E-12	1.91E-13	---	8.81E-13	1.27E-07	2.69E-18
Nd-147	6.59E-07	7.62E-07	4.56E-08	---	4.45E-07	2.76E-05	2.16E-05

Table 9 - Inhalation Dose Factors for Adult
(mrem per pCi Inhaled)

Nuclide	Bone	Liver	T. Body	Thyroid	Kidney	Lung	GI-LLI
W-187	1.06E-09	8.85E-10	3.10E-10	---	---	3.63E-06	1.94E-05
Pu-238	1.43E+00	9.71E-01	6.90E-02	---	2.96E-01	1.82E-01	4.52E-05
Pu-239	1.66E+00	1.07E+00	7.75E-02	---	3.30E-01	1.72E-01	4.13E-05
Pu-240	1.65E+00	1.07E+00	7.73E-02	---	3.29E-01	1.72E-01	4.21E-05
Pu-241	3.42E-02	8.69E-03	1.29E-03	---	5.93E-03	1.52E-04	8.65E-07
Np-239	2.87E-08	2.54E-08	1.55E-09	---	8.75E-09	4.70E-06	1.49E-05
Am-241	1.68E+00	1.13E+00	6.71E-02	---	5.04E-01	6.06E-02	4.60E-05
Cm-242	2.22E-02	1.77E-02	9.84E-04	---	4.48E-03	3.92E-02	4.91E-05
Cm-243	1.10E+00	7.61E-01	4.61E-02	---	2.15E-01	6.31E-02	4.84E-05
Cm-244	8.37E-01	5.88E-01	3.51E-02	---	1.64E-01	6.06E-02	4.68E-05

Table 10 - Inhalation Dose Factors for Teenager
(mrem per pCi Inhaled)

Nuclide	Bone	Liver	T. Body	Thyroid	Kidney	Lung	GI-LLI
H-3	---	9.06E-08	9.06E-08	9.06E-08	9.06E-08	9.06E-08	9.06E-08
C-14	3.25E-06	6.09E-07	6.09E-07	6.09E-07	6.09E-07	6.09E-07	6.09E-07
Na-24	1.72E-06	1.72E-06	1.72E-06	1.72E-06	1.72E-06	1.72E-06	1.72E-06
P-32	2.36E-04	1.37E-05	8.95E-06	---	---	---	1.16E-05
Cr-51	---	---	1.69E-08	9.37E-09	3.84E-09	2.62E-06	3.75E-07
Mn-54	---	6.39E-06	1.05E-06	---	1.59E-06	2.48E-04	8.35E-06
Mn-56	---	2.12E-10	3.15E-11	---	2.24E-10	1.90E-06	7.18E-06
Fe-55	4.18E-06	2.98E-06	6.93E-07	---	---	1.55E-05	7.99E-07
Fe-59	1.99E-06	4.62E-06	1.79E-06	---	---	1.91E-04	2.23E-05
Co-58	---	2.59E-07	3.47E-07	---	---	1.68E-04	1.19E-05
Co-60	---	1.89E-06	2.48E-06	---	---	1.09E-03	3.24E-05
Ni-59	5.44E-06	2.02E-06	9.24E-07	---	---	1.41E-05	6.48E-07
Ni-63	7.25E-05	5.43E-06	2.47E-06	---	---	3.84E-05	1.77E-06
Ni-65	2.73E-10	3.66E-11	1.59E-11	---	---	1.17E-06	4.59E-06
Cu-64	---	2.54E-10	1.06E-10	---	8.01E-10	1.39E-06	7.68E-06
Zn-65	4.82E-06	1.67E-05	7.80E-06	---	1.08E-05	1.55E-04	5.83E-06
Zn-69	6.04E-12	1.15E-11	8.07E-13	---	7.53E-12	1.98E-07	3.56E-08
Br-83	---	---	4.30E-08	---	---	---	---
Br-84	---	---	5.41E-08	---	---	---	---
Br-85	---	---	2.29E-09	---	---	---	---
Rb-86	---	2.38E-05	1.05E-05	---	---	---	2.21E-06
Rb-88	---	6.82E-08	3.40E-08	---	---	---	3.65E-15
Rb-89	---	4.40E-08	2.91E-08	---	---	---	4.22E-17
Sr-89	5.43E-05	---	1.56E-06	---	---	3.02E-04	4.64E-05
Sr-90	4.14E-03	---	8.33E-05	---	---	2.06E-03	9.56E-05
Sr-91	1.10E-08	---	4.39E-10	---	---	7.59E-06	3.24E-05
Sr-92	1.19E-09	---	5.08E-11	---	---	3.43E-06	1.49E-05
Y-90	3.73E-07	---	1.00E-08	---	---	3.66E-05	6.99E-05
Y-91M	4.63E-11	---	1.77E-12	---	---	4.00E-07	3.77E-09
Y-91	8.26E-05	---	2.21E-06	---	---	3.67E-04	5.11E-05
Y-92	1.84E-09	---	5.36E-11	---	---	3.35E-06	2.06E-05
Y-93	1.69E-08	---	4.65E-10	---	---	1.04E-05	7.24E-05
Zr-95	1.82E-05	5.73E-06	3.94E-06	---	8.42E-06	3.36E-04	1.86E-05
Zr-97	1.72E-08	3.40E-09	1.57E-09	---	5.15E-09	1.62E-05	7.88E-05
Nb-95	2.32E-06	1.29E-06	7.08E-07	---	1.25E-06	9.39E-05	1.21E-05
Mo-99	---	2.11E-08	4.03E-09	---	5.14E-08	1.92E-05	3.36E-05
Tc-99M	1.73E-13	4.83E-13	6.24E-12	---	7.20E-12	1.44E-07	7.66E-07

Table 10 - Inhalation Dose Factors for Teenager
(mrem per pCi Inhaled)

Nuclide	Bone	Liver	T. Body	Thyroid	Kidney	Lung	GI-LLI
Tc-101	7.40E-15	1.05E-14	1.03E-13	---	1.90E-13	8.34E-08	1.09E-16
Ru-103	2.63E-07	---	1.12E-07	---	9.29E-07	9.79E-05	1.36E-05
Ru-105	1.40E-10	---	5.42E-11	---	1.76E-10	2.27E-06	1.13E-05
Ru-106	1.23E-05	---	1.55E-06	---	2.38E-05	2.01E-03	1.20E-04
Ag-110M	1.73E-06	1.64E-06	9.99E-07	---	3.13E-06	8.44E-04	3.41E-05
Sb-124	5.38E-06	9.92E-08	2.10E-06	1.22E-08	---	4.81E-04	4.98E-05
Sb-125	9.23E-06	1.01E-07	2.15E-06	8.80E-09	---	3.42E-04	1.24E-05
Te-125M	6.10E-07	2.80E-07	8.34E-08	1.75E-07	---	6.70E-05	9.38E-06
Te-127M	2.25E-06	1.02E-06	2.73E-07	5.48E-07	8.17E-06	2.07E-04	1.99E-05
Te-127	2.51E-10	1.14E-10	5.52E-11	1.77E-10	9.10E-10	1.40E-06	1.01E-05
Te-129M	1.74E-06	8.23E-07	2.81E-07	5.72E-07	6.49E-06	2.47E-04	5.06E-05
Te-129	8.87E-12	4.22E-12	2.20E-12	6.48E-12	3.32E-11	4.12E-07	2.02E-07
Te-131M	1.23E-08	7.51E-09	5.03E-09	9.06E-09	5.49E-08	2.97E-05	7.76E-05
Te-131	1.97E-12	1.04E-12	6.30E-13	1.55E-12	7.72E-12	2.92E-07	1.89E-09
Te-132	4.50E-08	3.63E-08	2.74E-08	3.07E-08	2.44E-07	5.61E-05	5.79E-05
I-130	7.80E-07	2.24E-06	8.96E-07	1.86E-04	3.44E-06	---	1.14E-06
I-131	4.43E-06	6.14E-06	3.30E-06	1.83E-03	1.05E-05	---	8.11E-07
I-132	1.99E-07	5.47E-07	1.97E-07	1.89E-05	8.65E-07	---	1.59E-07
I-133	1.52E-06	2.56E-06	7.78E-07	3.65E-04	4.49E-06	---	1.29E-06
I-134	1.11E-07	2.90E-07	1.05E-07	4.94E-06	4.58E-07	---	2.55E-09
I-135	4.62E-07	1.18E-06	4.36E-07	7.76E-05	1.86E-06	---	8.69E-07
Cs-134	6.28E-05	1.41E-04	6.86E-05	---	4.69E-05	1.83E-05	1.22E-06
Cs-136	6.44E-06	2.42E-05	1.71E-05	---	1.38E-05	2.22E-06	1.36E-06
Cs-137	8.38E-05	1.06E-04	3.89E-05	---	3.80E-05	1.51E-05	1.06E-06
Cs-138	5.82E-08	1.07E-07	5.58E-08	---	8.28E-08	9.84E-09	3.38E-11
Ba-139	1.67E-10	1.18E-13	4.87E-12	---	1.11E-13	8.08E-07	8.06E-07
Ba-140	6.84E-06	8.38E-09	4.40E-07	---	2.85E-09	2.54E-04	2.86E-05
Ba-141	1.78E-11	1.32E-14	5.93E-13	---	1.23E-14	4.11E-07	9.33E-14
Ba-142	4.62E-12	4.63E-15	2.84E-13	---	3.92E-15	2.39E-07	5.99E-20
La-140	5.99E-08	2.95E-08	7.82E-09	---	---	2.68E-05	6.09E-05
La-142	1.20E-10	5.31E-11	1.32E-11	---	---	1.27E-06	1.50E-06
Ce-141	3.55E-06	2.37E-06	2.71E-07	---	1.11E-06	7.67E-05	1.58E-05
Ce-143	3.32E-08	2.42E-08	2.70E-09	---	1.08E-08	1.63E-05	3.19E-05
Ce-144	6.11E-04	2.53E-04	3.28E-05	---	1.51E-04	1.67E-03	1.08E-04
Pr-143	1.67E-06	6.64E-07	8.28E-08	---	3.86E-07	6.04E-05	2.67E-05
Pr-144	5.37E-12	2.20E-12	2.72E-13	---	1.26E-12	2.19E-07	2.94E-14
Nd-147	9.83E-07	1.07E-06	6.41E-08	---	6.28E-07	4.65E-05	2.28E-05

Table 10 - Inhalation Dose Factors for Teenager
(mrem per pCi Inhaled)

Nuclide	Bone	Liver	T. Body	Thyroid	Kidney	Lung	GI-LLI
W-187	1.50E-09	1.22E-09	4.29E-10	---	---	5.92E-06	2.21E-05
Pu-238	1.50E+00	1.03E+00	7.22E-02	---	3.10E-01	3.12E-01	4.79E-05
Pu-239	1.73E+00	1.12E+00	8.05E-02	---	3.44E-01	2.93E-01	4.37E-05
Pu-240	1.72E+00	1.12E+00	8.04E-02	---	3.43E-01	2.93E-01	4.46E-05
Pu-241	3.74E-02	9.56E-03	1.40E-03	---	6.47E-03	2.60E-04	9.17E-07
Np-239	4.23E-08	3.60E-08	2.21E-09	---	1.25E-08	8.11E-06	1.65E-05
Am-241	1.77E+00	1.20E+00	7.10E-02	---	5.32E-01	1.05E-01	4.88E-05
Cm-242	3.17E-02	2.51E-02	1.41E-03	---	6.40E-03	6.76E-02	5.21E-05
Cm-243	1.19E+00	8.30E-01	5.00E-02	---	2.34E-01	1.09E-01	5.13E-05
Cm-244	9.19E-01	6.53E-01	3.88E-02	---	1.81E-01	1.05E-01	4.96E-05

Table 11 - Inhalation Dose Factors for Child
(mrem per pCi Inhaled)

Nuclide	Bone	Liver	T. Body	Thyroid	Kidney	Lung	GI-LLI
H-3	---	1.73E-07	1.73E-07	1.73E-07	1.73E-07	1.73E-07	1.73E-07
C-14	9.70E-06	1.82E-06	1.82E-06	1.82E-06	1.82E-06	1.82E-06	1.82E-06
Na-24	4.35E-06	4.35E-06	4.35E-06	4.35E-06	4.35E-06	4.35E-06	4.35E-06
P-32	7.04E-04	3.09E-05	2.67E-05	---	---	---	1.14E-05
Cr-51	---	---	4.17E-08	2.31E-08	6.57E-09	4.59E-06	2.93E-07
Mn-54	---	1.16E-05	2.57E-06	---	2.71E-06	4.26E-04	6.19E-06
Mn-56	---	4.48E-10	8.43E-11	---	4.52E-10	3.55E-06	3.33E-05
Fe-55	1.28E-05	6.80E-06	2.10E-06	---	---	3.00E-05	7.75E-07
Fe-59	5.59E-06	9.04E-06	4.51E-06	---	---	3.43E-04	1.91E-05
Co-58	---	4.79E-07	8.55E-07	---	---	2.99E-04	9.29E-06
Co-60	---	3.55E-06	6.12E-06	---	---	1.91E-03	2.60E-05
Ni-59	1.66E-05	4.67E-06	2.83E-06	---	---	2.73E-05	6.29E-07
Ni-63	2.22E-04	1.25E-05	7.56E-06	---	---	7.43E-05	1.71E-06
Ni-65	8.08E-10	7.99E-11	4.44E-11	---	---	2.21E-06	2.27E-05
Cu-64	---	5.39E-10	2.90E-10	---	1.63E-09	2.59E-06	9.92E-06
Zn-65	1.15E-05	3.06E-05	1.90E-05	---	1.93E-05	2.69E-04	4.41E-06
Zn-69	1.81E-11	2.61E-11	2.41E-12	---	1.58E-11	3.84E-07	2.75E-06
Br-83	---	---	1.28E-07	---	---	---	---
Br-84	---	---	1.48E-07	---	---	---	---
Br-85	---	---	6.84E-09	---	---	---	---
Rb-86	---	5.36E-05	3.09E-05	---	---	---	2.16E-06
Rb-88	---	1.52E-07	9.90E-08	---	---	---	4.66E-09
Rb-89	---	9.33E-08	7.85E-08	---	---	---	5.11E-10
Sr-89	1.62E-04	---	4.66E-06	---	---	5.83E-04	4.52E-05
Sr-90	1.04E-02	---	2.07E-04	---	---	3.99E-03	9.28E-05
Sr-91	3.28E-08	---	1.24E-09	---	---	1.44E-05	4.70E-05
Sr-92	3.54E-09	---	1.42E-10	---	---	6.49E-06	6.55E-05
Y-90	1.11E-06	---	2.99E-08	---	---	7.07E-05	7.24E-05
Y-91M	1.37E-10	---	4.98E-12	---	---	7.60E-07	4.64E-07
Y-91	2.47E-04	---	6.59E-06	---	---	7.10E-04	4.97E-05
Y-92	5.50E-09	---	1.57E-10	---	---	6.46E-06	6.46E-05
Y-93	5.04E-08	---	1.38E-09	---	---	2.01E-05	1.05E-04
Zr-95	5.13E-05	1.13E-05	1.00E-05	---	1.61E-05	6.03E-04	1.65E-05
Zr-97	5.07E-08	7.34E-09	4.32E-09	---	1.05E-08	3.06E-05	9.49E-05
Nb-95	6.35E-06	2.48E-06	1.77E-06	---	2.33E-06	1.66E-04	1.00E-05
Mo-99	---	4.66E-08	1.15E-08	---	1.06E-07	3.66E-05	3.42E-05
Tc-99M	4.81E-13	9.41E-13	1.56E-11	---	1.37E-11	2.57E-07	1.30E-06

Table 11 - Inhalation Dose Factors for Child
(mrem per pCi Inhaled)

Nuclide	Bone	Liver	T. Body	Thyroid	Kidney	Lung	GI-LLI
Tc-101	2.19E-14	2.30E-14	2.91E-13	---	3.92E-13	1.58E-07	4.41E-09
Ru-103	7.55E-07	---	2.90E-07	---	1.90E-06	1.79E-04	1.21E-05
Ru-105	4.13E-10	---	1.50E-10	---	3.63E-10	4.30E-06	2.69E-05
Ru-106	3.68E-05	---	4.57E-06	---	4.97E-05	3.87E-03	1.16E-04
Ag-110M	4.56E-06	3.08E-06	2.47E-06	---	5.74E-06	1.48E-03	2.71E-05
Sb-124	1.55E-05	2.00E-07	5.41E-06	3.41E-08	---	8.76E-04	4.43E-05
Sb-125	2.66E-05	2.05E-07	5.59E-06	2.46E-08	---	6.27E-04	1.09E-05
Te-125M	1.82E-06	6.29E-07	2.47E-07	5.20E-07	---	1.29E-04	9.13E-06
Te-127M	6.72E-06	2.31E-06	8.16E-07	1.64E-06	1.72E-05	4.00E-04	1.93E-05
Te-127	7.49E-10	2.57E-10	1.65E-10	5.30E-10	1.91E-09	2.71E-06	1.52E-05
Te-129M	5.19E-06	1.85E-06	8.22E-07	1.71E-06	1.36E-05	4.76E-04	4.91E-05
Te-129	2.64E-11	9.45E-12	6.44E-12	1.93E-11	6.94E-11	7.93E-07	6.89E-06
Te-131M	3.63E-08	1.60E-08	1.37E-08	2.64E-08	1.08E-07	5.56E-05	8.32E-05
Te-131	5.87E-12	2.28E-12	1.78E-12	4.59E-12	1.59E-11	5.55E-07	3.60E-07
Te-132	1.30E-07	7.36E-08	7.12E-08	8.58E-08	4.79E-07	1.02E-04	3.72E-05
I-130	2.21E-06	4.43E-06	2.28E-06	4.99E-04	6.61E-06	---	1.38E-06
I-131	1.30E-05	1.30E-05	7.37E-06	4.39E-03	2.13E-05	---	7.68E-07
I-132	5.72E-07	1.10E-06	5.07E-07	5.23E-05	1.69E-06	---	8.65E-07
I-133	4.48E-06	5.49E-06	2.08E-06	1.04E-03	9.13E-06	---	1.48E-06
I-134	3.17E-07	5.84E-07	2.69E-07	1.37E-05	8.92E-07	---	2.58E-07
I-135	1.33E-06	2.36E-06	1.12E-06	2.14E-04	3.62E-06	---	1.20E-06
Cs-134	1.76E-04	2.74E-04	6.07E-05	---	8.93E-05	3.27E-05	1.04E-06
Cs-136	1.76E-05	4.62E-05	3.14E-05	---	2.58E-05	3.93E-06	1.13E-06
Cs-137	2.45E-04	2.23E-04	3.47E-05	---	7.63E-05	2.81E-05	9.78E-07
Cs-138	1.71E-07	2.27E-07	1.50E-07	---	1.68E-07	1.84E-08	7.29E-08
Ba-139	4.98E-10	2.66E-13	1.45E-11	---	2.33E-13	1.56E-06	1.56E-05
Ba-140	2.00E-05	1.75E-08	1.17E-06	---	5.71E-09	4.71E-04	2.75E-05
Ba-141	5.29E-11	2.95E-14	1.72E-12	---	2.56E-14	7.89E-07	7.44E-08
Ba-142	1.35E-11	9.73E-15	7.54E-13	---	7.87E-15	4.44E-07	7.41E-10
La-140	1.74E-07	6.08E-08	2.04E-08	---	---	4.94E-05	6.10E-05
La-142	3.50E-10	1.11E-10	3.49E-11	---	---	2.35E-06	2.05E-05
Ce-141	1.06E-05	5.28E-06	7.83E-07	---	2.31E-06	1.47E-04	1.53E-05
Ce-143	9.89E-08	5.37E-08	7.77E-09	---	2.26E-08	3.12E-05	3.44E-05
Ce-144	1.83E-03	5.72E-04	9.77E-05	---	3.17E-04	3.23E-03	1.05E-04
Pr-143	4.99E-06	1.50E-06	2.47E-07	---	8.11E-07	1.17E-04	2.63E-05
Pr-144	1.61E-11	4.99E-12	8.10E-13	---	2.64E-12	4.23E-07	5.32E-08
Nd-147	2.92E-06	2.36E-06	1.84E-07	---	1.30E-06	8.87E-05	2.22E-05

Table 11 - Inhalation Dose Factors for Child
(mrem per pCi Inhaled)

Nuclide	Bone	Liver	T. Body	Thyroid	Kidney	Lung	GI-LLI
W-187	4.41E-09	2.61E-09	1.17E-09	---	---	1.11E-05	2.46E-05
Pu-238	2.55E+00	1.60E+00	1.21E-01	---	4.47E-01	6.08E-01	4.65E-05
Pu-239	2.79E+00	1.68E+00	1.28E-01	---	4.78E-01	5.72E-01	4.24E-05
Pu-240	2.79E+00	1.68E+00	1.27E-01	---	4.77E-01	5.71E-01	4.33E-05
Pu-241	7.94E-02	1.75E-02	2.93E-03	---	1.10E-02	5.06E-04	8.90E-07
Np-239	1.26E-07	8.14E-08	6.35E-09	---	2.63E-08	1.57E-05	1.73E-05
Am-241	2.97E+00	1.84E+00	1.24E-01	---	7.63E-01	2.02E-01	4.73E-05
Cm-242	9.48E-02	5.68E-02	4.20E-03	---	1.34E-02	1.31E-01	5.06E-05
Cm-243	2.32E+00	1.42E+00	9.95E-02	---	3.74E-01	2.10E-01	4.98E-05
Cm-244	1.94E+00	1.18E+00	8.31E-02	---	3.06E-01	2.02E-01	4.82E-05

Table 12 - Inhalation Dose Factors for Infant
(mrem per pCi Inhaled)

Nuclide	Bone	Liver	T. Body	Thyroid	Kidney	Lung	GI-LLI
H-3	---	2.63E-07	2.63E-07	2.63E-07	2.63E-07	2.63E-07	2.63E-07
C-14	1.89E-05	3.79E-06	3.79E-06	3.79E-06	3.79E-06	3.79E-06	3.79E-06
Na-24	7.54E-06	7.54E-06	7.54E-06	7.54E-06	7.54E-06	7.54E-06	7.54E-06
P-32	1.45E-03	8.03E-05	5.53E-05	---	---	---	1.15E-05
Cr-51	---	---	6.39E-08	4.11E-08	9.45E-09	9.17E-06	2.55E-07
Mn-54	---	1.81E-05	3.56E-06	---	3.56E-06	7.14E-04	5.04E-06
Mn-56	---	1.10E-09	1.58E-10	---	7.86E-10	8.95E-06	5.12E-05
Fe-55	1.41E-05	8.39E-06	2.38E-06	---	---	6.21E-05	7.82E-07
Fe-59	9.69E-06	1.68E-05	6.77E-06	---	---	7.25E-04	1.77E-05
Co-58	---	8.71E-07	1.30E-06	---	---	5.55E-04	7.95E-06
Co-60	---	5.73E-06	8.41E-06	---	---	3.22E-03	2.28E-05
Ni-59	1.81E-05	5.44E-06	3.10E-06	---	---	5.48E-05	6.34E-07
Ni-63	2.42E-04	1.46E-05	8.29E-06	---	---	1.49E-04	1.73E-06
Ni-65	1.71E-09	2.03E-10	8.79E-11	---	---	5.80E-06	3.58E-05
Cu-64	---	1.34E-09	5.53E-10	---	2.84E-09	6.64E-06	1.07E-05
Zn-65	1.38E-05	4.47E-05	2.22E-05	---	2.32E-05	4.62E-04	3.67E-05
Zn-69	3.85E-11	6.91E-11	5.13E-12	---	2.87E-11	1.05E-06	9.44E-06
Br-83	---	---	2.72E-07	---	---	---	---
Br-84	---	---	2.86E-07	---	---	---	---
Br-85	---	---	1.46E-08	---	---	---	---
Rb-86	---	1.36E-04	6.30E-05	---	---	---	2.17E-06
Rb-88	---	3.98E-07	2.05E-07	---	---	---	2.42E-07
Rb-89	---	2.29E-07	1.47E-07	---	---	---	4.87E-08
Sr-89	2.84E-04	---	8.15E-06	---	---	1.45E-03	4.57E-05
Sr-90	1.11E-02	---	2.23E-04	---	---	8.03E-03	9.36E-05
Sr-91	6.83E-08	---	2.47E-09	---	---	3.76E-05	5.24E-05
Sr-92	7.50E-09	---	2.79E-10	---	---	1.70E-05	1.00E-04
Y-90	2.35E-06	---	6.30E-08	---	---	1.92E-04	7.43E-05
Y-91M	2.91E-10	---	9.90E-12	---	---	1.99E-06	1.68E-06
Y-91	4.20E-04	---	1.12E-05	---	---	1.75E-03	5.02E-05
Y-92	1.17E-08	---	3.29E-10	---	---	1.75E-05	9.04E-05
Y-93	1.07E-07	---	2.91E-09	---	---	5.46E-05	1.19E-04
Zr-95	8.24E-05	1.99E-05	1.45E-05	---	2.22E-05	1.25E-03	1.55E-05
Zr-97	1.07E-07	1.83E-08	8.36E-09	---	1.85E-08	7.88E-05	1.00E-04
Nb-95	1.12E-05	4.59E-06	2.70E-06	---	3.37E-06	3.42E-04	9.05E-06
Mo-99	---	1.18E-07	2.31E-08	---	1.89E-07	9.63E-05	3.48E-05
Tc-99M	9.98E-13	2.06E-12	2.66E-11	---	2.22E-11	5.79E-07	1.45E-06

Table 12 - Inhalation Dose Factors for Infant
(mrem per pCi Inhaled)

Nuclide	Bone	Liver	T. Body	Thyroid	Kidney	Lung	GI-LLI
Tc-101	4.65E-14	5.88E-14	5.80E-13	---	6.99E-13	4.17E-07	6.03E-07
Ru-103	1.44E-06	---	4.85E-07	---	3.03E-06	3.94E-04	1.15E-05
Ru-105	8.74E-10	---	2.93E-10	---	6.42E-10	1.12E-05	3.46E-05
Ru-106	6.20E-05	---	7.77E-06	---	7.61E-05	8.26E-03	1.17E-04
Ag-110M	7.13E-06	5.16E-06	3.57E-06	---	7.80E-06	2.62E-03	2.36E-05
Sb-124	2.71E-05	3.97E-07	8.56E-06	7.18E-08	---	1.89E-03	4.22E-05
Sb-125	3.69E-05	3.41E-07	7.78E-06	4.45E-08	---	1.17E-03	1.05E-05
Te-125M	3.40E-06	1.42E-06	4.70E-07	1.16E-06	---	3.19E-04	9.22E-06
Te-127M	1.19E-05	4.93E-06	1.48E-06	3.48E-06	2.68E-05	9.37E-04	1.95E-05
Te-127	1.59E-09	6.81E-10	3.40E-10	1.32E-09	3.47E-09	7.39E-06	1.74E-05
Te-129M	1.01E-05	4.35E-06	1.59E-06	3.91E-06	2.27E-05	1.20E-03	4.93E-05
Te-129	5.63E-11	2.48E-11	1.34E-11	4.82E-11	1.25E-10	2.14E-06	1.88E-05
Te-131M	7.62E-08	3.93E-08	2.59E-08	6.38E-08	1.89E-07	1.42E-04	8.51E-05
Te-131	1.24E-11	5.87E-12	3.57E-12	1.13E-11	2.85E-11	1.47E-06	5.87E-06
Te-132	2.66E-07	1.69E-07	1.26E-07	1.99E-07	7.39E-07	2.43E-04	3.15E-05
I-130	4.54E-06	9.91E-06	3.98E-06	1.14E-03	1.09E-05	---	1.42E-06
I-131	2.71E-05	3.17E-05	1.40E-05	1.06E-02	3.70E-05	---	7.56E-07
I-132	1.21E-06	2.53E-06	8.99E-07	1.21E-04	2.82E-06	---	1.36E-06
I-133	9.46E-06	1.37E-05	4.00E-06	2.54E-03	1.60E-05	---	1.54E-06
I-134	6.58E-07	1.34E-06	4.75E-07	3.18E-05	1.49E-06	---	9.21E-07
I-135	2.76E-06	5.43E-06	1.98E-06	4.97E-04	6.05E-06	---	1.31E-06
Cs-134	2.83E-04	5.02E-04	5.32E-05	---	1.36E-04	5.69E-05	9.53E-07
Cs-136	3.45E-05	9.61E-05	3.78E-05	---	4.03E-05	8.40E-06	1.02E-06
Cs-137	3.92E-04	4.37E-04	3.25E-05	---	1.23E-04	5.09E-05	9.53E-07
Cs-138	3.61E-07	5.58E-07	2.84E-07	---	2.93E-07	4.67E-08	6.26E-07
Ba-139	1.06E-09	7.03E-13	3.07E-11	---	4.23E-13	4.25E-06	3.64E-05
Ba-140	4.00E-05	4.00E-08	2.07E-06	---	9.59E-09	1.14E-03	2.74E-05
Ba-141	1.12E-10	7.70E-14	3.55E-12	---	4.64E-14	2.12E-06	3.39E-06
Ba-142	2.84E-11	2.36E-14	1.40E-12	---	1.36E-14	1.11E-06	4.95E-07
La-140	3.61E-07	1.43E-07	3.68E-08	---	---	1.20E-04	6.06E-05
La-142	7.36E-10	2.69E-10	6.46E-11	---	---	5.87E-06	4.25E-05
Ce-141	1.98E-05	1.19E-05	1.42E-06	---	3.75E-06	3.69E-04	1.54E-05
Ce-143	2.09E-07	1.38E-07	1.58E-08	---	4.03E-08	8.30E-05	3.55E-05
Ce-144	2.28E-03	8.65E-04	1.26E-04	---	3.84E-04	7.03E-03	1.06E-04
Pr-143	1.00E-05	3.74E-06	4.99E-07	---	1.41E-06	3.09E-04	2.66E-05
Pr-144	3.42E-11	1.32E-11	1.72E-12	---	4.80E-12	1.15E-06	3.06E-06
Nd-147	5.67E-06	5.81E-06	3.57E-07	---	2.25E-06	2.30E-04	2.23E-05

Table 12 - Inhalation Dose Factors for Infant
(mrem per pCi Inhaled)

Nuclide	Bone	Liver	T. Body	Thyroid	Kidney	Lung	GI-LLI
W-187	9.26E-09	6.44E-09	2.23E-09	---	---	2.83E-05	2.54E-05
Pu-238	2.69E+00	1.68E+00	1.27E-01	---	4.64E-01	9.03E-01	4.69E-05
Pu-239	2.93E+00	1.76E+00	1.34E-01	---	4.95E-01	8.47E-01	4.28E-05
Pu-240	2.93E+00	1.75E+00	1.34E-01	---	4.94E-01	8.47E-01	4.36E-05
Pu-241	8.43E-02	1.85E-02	3.11E-03	---	1.15E-02	7.62E-04	8.97E-07
Np-239	2.65E-07	2.13E-07	1.34E-08	---	4.73E-08	4.25E-05	1.78E-05
Am-241	3.15E+00	1.95E+00	1.31E-01	---	7.94E-01	4.06E-01	4.78E-05
Cm-242	1.28E-01	8.65E-02	5.70E-03	---	1.69E-02	2.97E-01	5.10E-05
Cm-243	2.47E+00	1.52E+00	1.06E-01	---	3.91E-01	4.24E-01	5.02E-05
CM-244	2.07E+00	1.27E+00	8.89E-02	---	3.21E-01	4.08E-01	4.86E-05

Table 13 - Ingestion Dose Factors for Adult
(mrem per pCi Ingested)

Nuclide	Bone	Liver	T. Body	Thyroid	Kidney	Lung	GI-LLI
H-3	---	5.99E-08	5.99E-08	5.99E-08	5.99E-08	5.99E-08	5.99E-08
C-14	2.84E-06	5.68E-07	5.68E-07	5.68E-07	5.68E-07	5.68E-07	5.68E-07
Na-24	1.70E-06	1.70E-06	1.70E-06	1.70E-06	1.70E-06	1.70E-06	1.70E-06
P-32	1.93E-04	1.20E-05	7.46E-06	---	---	---	2.17E-05
Cr-51	---	---	2.66E-09	1.59E-09	5.86E-10	3.53E-09	6.69E-07
Mn-54	---	4.57E-06	8.72E-07	---	1.36E-06	---	1.40E-05
Mn-56	---	1.15E-07	2.04E-08	---	1.46E-07	---	3.67E-06
Fe-55	2.75E-06	1.90E-06	4.43E-07	---	---	1.06E-06	1.09E-06
Fe-59	4.34E-06	1.02E-05	3.91E-06	---	---	2.85E-06	3.40E-05
Co-58	---	7.45E-07	1.67E-06	---	---	---	1.51E-05
Co-60	---	2.14E-06	4.72E-06	---	---	---	4.02E-05
Ni-59	9.76E-06	3.35E-06	1.63E-06	---	---	---	6.90E-07
Ni-63	1.30E-04	9.01E-06	4.36E-06	---	---	---	1.88E-06
Ni-65	5.28E-07	6.86E-08	3.13E-08	---	---	---	1.74E-06
Cu-64	---	8.33E-08	3.91E-08	---	2.10E-07	---	7.10E-06
Zn-65	4.84E-06	1.54E-05	6.96E-06	---	1.03E-05	---	9.70E-06
Zn-69	1.03E-08	1.97E-08	1.37E-09	---	1.28E-08	---	2.96E-09
Br-83	---	---	4.02E-08	---	---	---	5.79E-08
Br-84	---	---	5.21E-08	---	---	---	4.09E-13
Br-85	---	---	2.14E-09	---	---	---	---
Rb-86	---	2.11E-05	9.83E-06	---	---	---	4.16E-06
Rb-88	---	6.05E-08	3.21E-08	---	---	---	8.36E-19
Rb-89	---	4.01E-08	2.82E-08	---	---	---	2.33E-21
Sr-89	3.08E-04	---	8.84E-06	---	---	---	4.94E-05
Sr-90	8.71E-03	---	1.75E-04	---	---	---	2.19E-04
Sr-91	5.67E-06	---	2.29E-07	---	---	---	2.70E-05
Sr-92	2.15E-06	---	9.30E-08	---	---	---	4.26E-05
Y-90	9.62E-09	---	2.58E-10	---	---	---	1.02E-04
Y-91M	9.09E-11	---	3.52E-12	---	---	---	2.67E-10
Y-91	1.41E-07	---	3.77E-09	---	---	---	7.76E-05
Y-92	8.45E-10	---	2.47E-11	---	---	---	1.48E-05
Y-93	2.68E-09	---	7.40E-11	---	---	---	8.50E-05
Zr-95	3.04E-08	9.75E-09	6.60E-09	---	1.53E-08	---	3.09E-05
Zr-97	1.68E-09	3.39E-10	1.55E-10	---	5.12E-10	---	1.05E-04
Nb-95	6.22E-09	3.46E-09	1.86E-09	---	3.42E-09	---	2.10E-05
Mo-99	---	4.31E-06	8.20E-07	---	9.76E-06	---	9.99E-06
Tc-99M	2.47E-10	6.98E-10	8.89E-09	---	1.06E-08	3.42E-10	4.13E-07

Table 13 - Ingestion Dose Factors for Adult
(mrem per pCi Ingested)

Nuclide	Bone	Liver	T. Body	Thyroid	Kidney	Lung	GI-LLI
Tc-101	2.54E-10	3.66E-10	3.59E-09	---	6.59E-09	1.87E-10	1.10E-21
Ru-103	1.85E-07	---	7.97E-08	---	7.06E-07	---	2.16E-05
Ru-105	1.54E-08	---	6.08E-09	---	1.99E-07	---	9.42E-06
Ru-106	2.75E-06	---	3.48E-07	---	5.31E-06	---	1.78E-04
Ag-110M	1.60E-07	1.48E-07	8.79E-08	---	2.91E-07	---	6.04E-05
Sb-124	2.80E-06	5.29E-08	1.11E-06	6.79E-09	---	2.18E-06	7.95E-05
Sb-125	1.79E-06	2.00E-08	4.26E-07	1.82E-09	---	1.38E-06	1.97E-05
Te-125M	2.68E-06	9.71E-07	3.59E-07	8.06E-07	1.09E-05	---	1.07E-05
Te-127M	6.77E-06	2.42E-06	8.25E-07	1.73E-06	2.75E-05	---	2.27E-05
Te-127	1.10E-07	3.95E-08	2.38E-08	8.15E-08	4.48E-07	---	8.68E-06
Te-129M	1.15E-05	4.29E-06	1.82E-06	3.95E-06	4.80E-05	---	5.79E-05
Te-129	3.14E-08	1.18E-08	7.65E-09	2.41E-08	1.32E-07	---	2.37E-08
Te-131M	1.73E-06	8.46E-07	7.05E-07	1.34E-06	8.57E-06	---	8.40E-05
Te-131	1.97E-08	8.23E-09	6.22E-09	1.62E-08	8.63E-08	---	2.79E-09
Te-132	2.52E-06	1.63E-06	1.53E-06	1.80E-06	1.57E-05	---	7.71E-05
I-130	7.56E-07	2.23E-06	8.80E-07	1.89E-04	3.48E-06	---	1.92E-06
I-131	4.16E-06	5.95E-06	3.41E-06	1.95E-03	1.02E-05	---	1.57E-06
I-132	2.03E-07	5.43E-07	1.90E-07	1.90E-05	8.65E-07	---	1.02E-07
I-133	1.42E-06	2.47E-06	7.53E-07	3.63E-04	4.31E-06	---	2.22E-06
I-134	1.06E-07	2.88E-07	1.03E-07	4.99E-06	4.58E-07	---	2.51E-10
I-135	4.43E-07	1.16E-06	4.28E-07	7.65E-05	1.86E-06	---	1.31E-06
Cs-134	6.22E-05	1.48E-04	1.21E-04	---	4.79E-05	1.59E-05	2.59E-06
Cs-136	6.51E-06	2.57E-05	1.85E-05	---	1.43E-05	1.96E-06	2.92E-06
Cs-137	7.97E-05	1.09E-04	7.14E-05	---	3.70E-05	1.23E-05	2.11E-06
Cs-138	5.52E-08	1.09E-07	5.40E-08	---	8.01E-08	7.91E-09	4.65E-13
Ba-139	9.70E-08	6.91E-11	2.84E-09	---	6.46E-11	3.92E-11	1.72E-07
Ba-140	2.03E-05	2.55E-08	1.33E-06	---	8.67E-09	1.46E-08	4.18E-05
Ba-141	4.71E-08	3.56E-11	1.59E-09	---	3.31E-11	2.02E-11	2.22E-17
Ba-142	2.13E-08	2.19E-11	1.34E-09	---	1.85E-11	1.24E-11	3.00E-26
La-140	2.50E-09	1.26E-09	3.33E-10	---	---	---	9.25E-05
La-142	1.28E-10	5.82E-11	1.45E-11	---	---	---	4.25E-07
Ce-141	9.36E-09	6.33E-09	7.18E-10	---	2.94E-09	---	2.42E-05
Ce-143	1.65E-09	1.22E-06	1.35E-10	---	5.37E-10	---	4.56E-05
Ce-144	4.88E-07	2.04E-07	2.62E-08	---	1.21E-07	---	1.65E-04
Pr-143	9.20E-09	3.69E-09	4.56E-10	---	2.13E-09	---	4.03E-05
Pr-144	3.01E-11	1.25E-11	1.53E-12	---	7.05E-12	---	4.33E-18
Nd-147	6.29E-09	7.27E-09	4.35E-10	---	4.25E-09	---	3.49E-05

Table 13 - Ingestion Dose Factors for Adult
(mrem per pCi Ingested)

Nuclide	Bone	Liver	T. Body	Thyroid	Kidney	Lung	GI-LLI
W-187	1.03E-07	8.61E-08	3.01E-08	---	---	---	2.82E-05
Pu-238	6.30E-04	7.98E-05	1.71E-05	---	7.32E-05	---	7.30E-05
Pu-239	7.25E-04	8.71E-05	1.91E-05	---	8.11E-05	---	6.66E-05
Pu-240	7.24E-04	8.70E-05	1.91E-05	---	8.10E-05	---	6.78E-05
Pu-241	1.57E-05	7.45E-07	3.32E-07	---	1.53E-06	---	1.40E-06
Np-239	1.19E-09	1.17E-10	6.45E-11	---	3.65E-10	---	2.40E-05
Am-241	7.55E-04	7.05E-04	5.41E-05	---	4.07E-04	---	7.42E-05
Cm-242	2.06E-05	2.19E-05	1.37E-06	---	6.22E-06	---	7.92E-05
Cm-243	5.99E-04	5.49E-04	3.75E-05	---	1.75E-04	---	7.81E-05
Cm-244	4.56E-04	4.27E-04	2.87E-05	---	1.34E-04	---	7.55E-05

Table 14 - Ingestion Dose Factors for Teenager
(mrem per pCi Ingested)

Nuclide	Bone	Liver	T. Body	Thyroid	Kidney	Lung	GI-LLI
H-3	--	6.04E-08	6.04E-08	6.04E-08	6.04E-08	6.04E-08	6.04E-08
C-14	4.06E-06	8.12E-07	8.12E-07	8.12E-07	8.12E-07	8.12E-07	8.12E-07
Na-24	2.30E-06	2.30E-06	2.30E-06	2.30E-06	2.30E-06	2.30E-06	2.30E-06
P-32	2.76E-04	1.71E-05	1.07E-05	---	---	---	2.32E-05
Cr-51	---	---	3.60E-09	2.00E-09	7.89E-10	5.14E-09	6.05E-07
Mn-54	---	5.90E-06	1.17E-06	---	1.76E-06	---	1.21E-05
Mn-56	---	1.58E-07	2.81E-08	---	2.00E-07	---	1.04E-05
Fe-55	3.78E-06	2.68E-06	6.25E-07	---	---	1.70E-06	1.16E-06
Fe-59	5.87E-06	1.37E-05	5.29E-06	---	---	4.32E-06	3.24E-05
Co-58	---	9.72E-07	2.24E-06	---	---	---	1.34E-05
Co-60	---	2.81E-06	6.33E-06	---	---	---	3.66E-05
Ni-59	1.32E-05	4.66E-06	2.24E-06	---	---	---	7.31E-07
Ni-63	1.77E-04	1.25E-05	6.00E-06	---	---	---	1.99E-06
Ni-65	7.49E-07	9.57E-08	4.36E-08	---	---	---	5.19E-06
Cu-64	---	1.15E-07	5.41E-08	---	2.91E-07	---	8.92E-06
Zn-65	5.76E-06	2.00E-05	9.33E-06	---	1.28E-05	---	8.47E-06
Zn-69	1.47E-08	2.80E-08	1.96E-09	---	1.83E-08	---	5.16E-08
Br-83	---	---	5.74E-08	---	---	---	---
Br-84	---	---	7.22E-08	---	---	---	---
Br-85	---	---	3.05E-09	---	---	---	---
Rb-86	---	2.98E-05	1.40E-05	---	---	---	4.41E-06
Rb-88	---	8.52E-08	4.54E-08	---	---	---	7.30E-15
Rb-89	---	5.50E-08	3.89E-08	---	---	---	8.43E-17
Sr-89	4.40E-04	---	1.26E-05	---	---	---	5.24E-05
Sr-90	1.02E-02	---	2.04E-04	---	---	---	2.33E-04
Sr-91	8.07E-06	---	3.21E-07	---	---	---	3.66E-05
Sr-92	3.05E-06	---	1.30E-07	---	---	---	7.77E-05
Y-90	1.37E-08	---	3.69E-10	---	---	---	1.13E-04
Y-91M	1.29E-10	---	4.93E-12	---	---	---	6.09E-09
Y-91	2.01E-07	---	5.39E-09	---	---	---	8.24E-05
Y-92	1.21E-09	---	3.50E-11	---	---	---	3.32E-05
Y-93	3.83E-09	---	1.05E-10	---	---	---	1.17E-04
Zr-95	4.12E-08	1.30E-08	8.94E-09	---	1.91E-08	---	3.00E-05
Zr-97	2.37E-09	4.69E-10	2.16E-10	---	7.11E-10	---	1.27E-04
Nb-95	8.22E-09	4.56E-09	2.51E-09	---	4.42E-09	---	1.95E-05
Mo-99	---	6.03E-06	1.15E-06	---	1.38E-05	---	1.08E-05
Tc-99M	3.32E-10	9.26E-10	1.20E-08	---	1.38E-08	5.14E-10	6.08E-07

Table 14 - Ingestion Dose Factors for Teenager
(mrem per pCi Ingested)

Nuclide	Bone	Liver	T. Body	Thyroid	Kidney	Lung	GI-LLI
Tc-101	3.60E-10	5.12E-10	5.03E-09	---	9.26E-09	3.12E-10	8.75E-17
Ru-103	2.55E-07	---	1.09E-07	---	8.99E-07	---	2.13E-05
Ru-105	2.18E-08	---	8.46E-09	---	2.75E-07	---	1.76E-05
Ru-106	3.92E-06	---	4.94E-07	---	7.56E-06	---	1.88E-04
Ag-110M	2.05E-07	1.94E-07	1.18E-07	---	3.70E-07	---	5.45E-05
Sb-124	3.87E-06	7.13E-08	1.51E-06	8.78E-09	---	3.38E-06	7.80E-05
Sb-125	2.48E-06	2.71E-08	5.80E-07	2.37E-09	---	2.18E-06	1.93E-05
Te-125M	3.83E-06	1.38E-06	5.12E-07	1.07E-06	---	---	1.13E-05
Te-127M	9.67E-06	3.43E-06	1.15E-06	2.30E-06	3.92E-05	---	2.41E-05
Te-127	1.58E-07	5.60E-08	3.40E-08	1.09E-07	6.40E-07	---	1.22E-05
Te-129M	1.63E-05	6.05E-06	2.58E-06	5.26E-06	6.82E-05	---	6.12E-05
Te-129	4.48E-08	1.67E-08	1.09E-08	3.20E-08	1.88E-07	---	2.45E-07
Te-131M	2.44E-06	1.17E-06	9.76E-07	1.76E-06	1.22E-05	---	9.39E-05
Te-131	2.79E-08	1.15E-08	8.72E-09	2.15E-08	1.22E-07	---	2.29E-09
Te-132	3.49E-06	2.21E-06	2.08E-06	2.33E-06	2.12E-05	---	7.00E-05
I-130	1.03E-06	2.98E-06	1.19E-06	2.43E-04	4.59E-06	---	2.29E-06
I-131	5.85E-06	8.19E-06	4.40E-06	2.39E-03	1.41E-05	---	1.62E-06
I-132	2.79E-07	7.30E-07	2.62E-07	2.46E-05	1.15E-06	---	3.18E-07
I-133	2.01E-06	3.41E-06	1.04E-06	4.76E-04	5.98E-06	---	2.58E-06
I-134	1.46E-07	3.87E-07	1.39E-07	6.45E-06	6.10E-07	---	5.10E-09
I-135	6.10E-07	1.57E-06	5.82E-07	1.01E-04	2.48E-06	---	1.74E-06
Cs-134	8.37E-05	1.97E-04	9.14E-05	---	6.26E-05	2.39E-05	2.45E-06
Cs-136	8.59E-06	3.38E-05	2.27E-05	---	1.84E-05	2.90E-06	2.72E-06
Cs-137	1.12E-04	1.49E-04	5.19E-05	---	5.07E-05	1.97E-05	2.12E-06
Cs-138	7.76E-08	1.49E-07	7.45E-08	---	1.10E-07	1.28E-08	4.76E-11
Ba-139	1.39E-07	9.78E-11	4.05E-09	---	9.22E-11	6.74E-11	1.24E-06
Ba-140	2.84E-05	3.48E-08	1.83E-06	---	1.18E-08	2.34E-08	4.38E-05
Ba-141	6.71E-08	5.01E-11	2.24E-09	---	4.65E-11	3.43E-11	1.43E-13
Ba-142	2.99E-08	2.99E-11	1.84E-09	---	2.53E-11	1.99E-11	9.18E-20
La-140	3.48E-09	1.71E-09	4.55E-10	---	---	---	9.28E-05
La-142	1.79E-10	7.95E-11	1.98E-11	---	---	---	2.42E-06
Ce-141	1.33E-08	8.88E-09	1.02E-09	---	4.18E-09	---	2.54E-05
Ce-143	2.35E-09	1.71E-06	1.91E-10	---	7.67E-10	---	5.14E-05
Ce-144	6.96E-07	2.88E-07	3.74E-08	---	1.72E-07	---	1.75E-04
Pr-143	1.31E-08	5.23E-09	6.52E-10	---	3.04E-09	---	4.31E-05
Pr-144	4.30E-11	1.76E-11	2.18E-12	---	1.01E-11	---	4.74E-14
Nd-147	9.38E-09	1.02E-08	6.11E-10	---	5.99E-09	---	3.68E-05

Table 14 - Ingestion Dose Factors for Teenager
(mrem per pCi Ingested)

Nuclide	Bone	Liver	T. Body	Thyroid	Kidney	Lung	GI-LLI
W-187	1.46E-07	1.19E-07	4.17E-08	---	---	---	3.22E-05
Pu-238	6.70E-04	8.58E-05	1.82E-05	---	7.80E-05	---	7.73E-05
Pu-239	7.65E-04	9.29E-05	2.01E-05	---	8.57E-05	---	7.06E-05
Pu-240	7.64E-04	9.27E-05	2.01E-05	---	8.56E-05	---	7.19E-05
Pu-241	1.75E-05	8.40E-07	3.69E-07	---	1.71E-06	---	1.48E-06
Np-239	1.76E-09	1.66E-10	9.22E-11	---	5.21E-10	---	2.67E-05
Am-241	7.98E-04	7.53E-04	5.75E-05	---	4.31E-04	---	7.87E-05
Cm-242	2.94E-05	3.10E-05	1.95E-06	---	8.89E-06	---	8.40E-05
Cm-243	6.50E-04	6.03E-04	4.09E-05	---	1.91E-04	---	8.28E-05
Cm-244	5.04E-04	4.77E-04	3.19E-05	---	1.49E-04	---	8.00E-05

Table 15 - Ingestion Dose Factors for Child
(mrem per pCi Ingested)

Nuclide	Bone	Liver	T. Body	Thyroid	Kidney	Lung	GI-LLI
H-3	---	1.16E-07	1.16E-07	1.16E-07	1.16E-07	1.16E-07	1.16E-07
C-14	1.21E-05	2.42E-06	2.42E-06	2.42E-06	2.42E-06	2.42E-06	2.42E-06
Na-24	5.80E-06	5.80E-06	5.80E-06	5.80E-06	5.80E-06	5.80E-06	5.80E-06
P-32	8.25E-04	3.86E-05	3.18E-05	---	---	---	2.28E-05
Cr-51	---	---	8.90E-09	4.94E-09	1.35E-09	9.02E-09	4.72E-07
Mn-54	---	1.07E-05	2.85E-06	---	3.00E-06	---	8.98E-06
Mn-56	---	3.34E-07	7.54E-08	---	4.04E-07	---	4.84E-05
Fe-55	1.15E-05	6.10E-06	1.89E-06	---	---	3.45E-06	1.13E-06
Fe-59	1.65E-05	2.67E-05	1.33E-05	---	---	7.74E-06	2.78E-05
Co-58	---	1.80E-06	5.51E-06	---	---	---	1.05E-05
Co-60	---	5.29E-06	1.56E-05	---	---	---	2.93E-05
Ni-59	4.02E-05	1.07E-05	6.82E-06	---	---	---	7.10E-07
Ni-63	5.38E-04	2.88E-05	1.83E-05	---	---	---	1.94E-06
Ni-65	2.22E-06	2.09E-07	1.22E-07	---	---	---	2.56E-05
Cu-64	---	2.45E-07	1.48E-07	---	5.92E-07	---	1.15E-05
Zn-65	1.37E-05	3.65E-05	2.27E-05	---	2.30E-05	---	6.41E-06
Zn-69	4.38E-08	6.33E-08	5.85E-09	---	3.84E-08	---	3.99E-06
Br-83	---	---	1.71E-07	---	---	---	---
Br-84	---	---	1.98E-07	---	---	---	---
Br-85	---	---	9.12E-09	---	---	---	---
Rb-86	---	6.70E-05	4.12E-05	---	---	---	4.31E-06
Rb-88	---	1.90E-07	1.32E-07	---	---	---	9.32E-09
Rb-89	---	1.17E-07	1.04E-07	---	---	---	1.02E-09
Sr-89	1.32E-03	---	3.77E-05	---	---	---	5.11E-05
Sr-90	2.56E-02	---	5.15E-04	---	---	---	2.29E-04
Sr-91	2.40E-05	---	9.06E-07	---	---	---	5.30E-05
Sr-92	9.03E-06	---	3.62E-07	---	---	---	1.71E-04
Y-90	4.11E-08	---	1.10E-09	---	---	---	1.17E-04
Y-91M	3.82E-10	---	1.39E-11	---	---	---	7.48E-07
Y-91	6.02E-07	---	1.61E-08	---	---	---	8.02E-05
Y-92	3.60E-09	---	1.03E-10	---	---	---	1.04E-04
Y-93	1.14E-08	---	3.13E-10	---	---	---	1.70E-04
Zr-95	1.16E-07	2.55E-08	2.27E-08	---	3.65E-08	---	2.66E-05
Zr-97	6.99E-09	1.01E-09	5.96E-10	---	1.45E-09	---	1.53E-04
Nb-95	2.25E-08	8.76E-09	6.26E-09	---	8.23E-09	---	1.62E-05
Mo-99	---	1.33E-05	3.29E-06	---	2.84E-05	---	1.10E-05
Tc-99M	9.23E-10	1.81E-09	3.00E-08	---	2.63E-08	9.19E-10	1.03E-06

Table 15 - Ingestion Dose Factors for Child
(mrem per pCi Ingested)

Nuclide	Bone	Liver	T. Body	Thyroid	Kidney	Lung	GI-LLI
Tc-101	1.07E-09	1.12E-09	1.42E-08	---	1.91E-08	5.92E-10	3.56E-09
Ru-103	7.31E-07	---	2.81E-07	---	1.84E-06	---	1.89E-05
Ru-105	6.45E-08	---	2.34E-08	---	5.67E-07	---	4.21E-05
Ru-106	1.17E-05	---	1.46E-06	---	1.58E-05	---	1.82E-04
Ag-110M	5.39E-07	3.64E-07	2.91E-07	---	6.78E-07	---	4.33E-05
Sb-124	1.11E-05	1.44E-07	3.89E-06	2.45E-08	---	6.16E-06	6.94E-05
Sb-125	7.16E-06	5.52E-08	1.50E-06	6.63E-09	---	3.99E-06	1.71E-05
Te-125M	1.14E-05	3.09E-06	1.52E-06	3.20E-06	---	---	1.10E-05
Te-127M	2.89E-05	7.78E-06	3.43E-06	6.91E-06	8.24E-05	---	2.34E-05
Te-127	4.71E-07	1.27E-07	1.01E-07	3.26E-07	1.34E-06	---	1.84E-05
Te-129M	4.87E-05	1.36E-05	7.56E-06	1.57E-05	1.43E-04	---	5.94E-05
Te-129	1.34E-07	3.74E-08	3.18E-08	9.56E-08	3.92E-07	---	8.34E-06
Te-131M	7.20E-06	2.49E-06	2.65E-06	5.12E-06	2.41E-05	---	1.01E-04
Te-131	8.30E-08	2.53E-08	2.47E-08	6.35E-08	2.51E-07	---	4.36E-07
Te-132	1.01E-05	4.47E-06	5.40E-06	6.51E-06	4.15E-05	---	4.50E-05
I-130	2.92E-06	5.90E-06	3.04E-06	6.50E-04	8.82E-06	---	2.76E-06
I-131	1.72E-05	1.73E-05	9.83E-06	5.72E-03	2.84E-05	---	1.54E-06
I-132	8.00E-07	1.47E-06	6.76E-07	6.82E-05	2.25E-06	---	1.73E-06
I-133	5.92E-06	7.32E-06	2.77E-06	1.36E-03	1.22E-05	---	2.95E-06
I-134	4.19E-07	7.78E-07	3.58E-07	1.79E-05	1.19E-06	---	5.16E-07
I-135	1.75E-06	3.15E-06	1.49E-06	2.79E-04	4.83E-06	---	2.40E-06
Cs-134	2.34E-04	3.84E-04	8.10E-05	---	1.19E-04	4.27E-05	2.07E-06
Cs-136	2.35E-05	6.46E-05	4.18E-05	---	3.44E-05	5.13E-06	2.27E-06
Cs-137	3.27E-04	3.13E-04	4.62E-05	---	1.02E-04	3.67E-05	1.96E-06
Cs-138	2.28E-07	3.17E-07	2.01E-07	---	2.23E-07	2.40E-08	1.46E-07
Ba-139	4.14E-07	2.21E-10	1.20E-08	---	1.93E-10	1.30E-10	2.39E-05
Ba-140	8.31E-05	7.28E-08	4.85E-06	---	2.37E-08	4.34E-08	4.21E-05
Ba-141	2.00E-07	1.12E-10	6.51E-09	---	9.69E-11	6.58E-10	1.14E-07
Ba-142	8.74E-08	6.29E-11	4.88E-09	---	5.09E-11	3.70E-11	1.14E-09
La-140	1.01E-08	3.53E-09	1.19E-09	---	---	---	9.84E-05
La-142	5.24E-10	1.67E-10	5.23E-11	---	---	---	3.31E-05
Ce-141	3.97E-08	1.98E-08	2.94E-09	---	8.68E-09	---	2.47E-05
Ce-143	6.99E-09	3.79E-06	5.49E-10	---	1.59E-09	---	5.55E-05
Ce-144	2.08E-06	6.52E-07	1.11E-07	---	3.61E-07	---	1.70E-04
Pr-143	3.93E-08	1.18E-08	1.95E-09	---	6.39E-09	---	4.24E-05
Pr-144	1.29E-10	3.99E-11	6.49E-12	---	2.11E-11	---	8.59E-08
Nd-147	2.79E-08	2.26E-08	1.75E-09	---	1.24E-08	---	3.58E-05

Table 15 - Ingestion Dose Factors for Child
(mrem per pCi Ingested)

Nuclide	Bone	Liver	T. Body	Thyroid	Kidney	Lung	GI-LLI
W-187	4.29E-07	2.54E-07	1.14E-07	---	---	---	3.57E-05
Pu-238	1.19E-03	1.38E-04	3.16E-05	---	1.15E-04	---	7.50E-05
Pu-239	1.29E-03	1.38E-04	3.31E-05	---	1.22E-04	---	6.85E-05
Pu-240	1.28E-03	1.43E-04	3.31E-05	---	1.22E-04	---	6.98E-05
Pu-241	3.87E-05	1.58E-06	8.04E-07	---	2.96E-06	---	1.44E-06
Np-239	5.25E-09	3.77E-10	2.65E-10	---	1.09E-09	---	2.79E-05
Am-241	1.36E-03	1.17E-03	1.02E-04	---	6.23E-04	---	7.64E-05
Cm-242	8.78E-05	7.01E-05	5.84E-06	---	1.87E-05	---	8.16E-05
Cm-243	1.28E-03	1.04E-03	8.24E-05	---	3.08E-04	---	8.03E-05
Cm-244	1.08E-03	8.74E-04	6.93E-05	---	2.54E-04	---	7.77E-05

Table 16 - Ingestion Dose Factors for Infant
(mrem per pCi Ingested)

Nuclide	Bone	Liver	T. Body	Thyroid	Kidney	Lung	GI-LLI
H-3	---	1.76E-07	1.76E-07	1.76E-07	1.76E-07	1.76E-07	1.76E-07
C-14	2.37E-05	5.06E-06	5.06E-06	5.06E-06	5.06E-06	5.06E-06	5.06E-06
Na-24	1.01E-05	1.01E-05	1.01E-05	1.01E-05	1.01E-05	1.01E-05	1.01E-05
P-32	1.70E-03	1.00E-04	6.59E-05	---	---	---	2.30E-05
Cr-51	---	---	1.41E-08	9.20E-09	2.01E-09	1.79E-08	4.11E-07
Mn-54	---	1.99E-05	4.51E-06	---	4.41E-06	---	7.31E-06
Mn-56	---	8.18E-07	1.41E-07	---	7.03E-07	---	7.43E-05
Fe-55	1.39E-05	8.98E-06	2.40E-06	---	---	4.36E-06	1.14E-06
Fe-59	3.08E-05	5.38E-05	2.12E-05	---	---	1.59E-05	2.57E-05
Co-58	---	3.60E-06	8.98E-06	---	---	---	8.97E-06
Co-60	---	1.08E-05	2.55E-05	---	---	---	2.57E-05
Ni-59	4.73E-05	1.45E-05	8.17E-06	---	---	---	7.16E-07
Ni-63	6.34E-04	3.92E-05	2.20E-05	---	---	---	1.95E-06
Ni-65	4.70E-06	5.32E-07	2.42E-07	---	---	---	4.05E-05
Cu-64	---	6.09E-07	2.82E-07	---	1.03E-06	---	1.25E-05
Zn-65	1.84E-05	6.31E-05	2.91E-05	---	3.06E-05	---	5.33E-05
Zn-69	9.33E-08	1.68E-07	1.25E-08	---	6.98E-08	---	1.37E-05
Br-83	---	---	3.63E-07	---	---	---	---
Br-84	---	---	3.82E-07	---	---	---	---
Br-85	---	---	1.94E-08	---	---	---	---
Rb-86	---	1.70E-04	8.40E-05	---	---	---	4.35E-06
Rb-88	---	4.98E-07	2.73E-07	---	---	---	4.85E-07
Rb-89	---	2.86E-07	1.97E-07	---	---	---	9.74E-08
Sr-89	2.51E-03	---	7.20E-05	---	---	---	5.16E-05
Sr-90	2.83E-02	---	5.74E-04	---	---	---	2.31E-04
Sr-91	5.00E-05	---	1.81E-06	---	---	---	5.92E-05
Sr-92	1.92E-05	---	7.13E-07	---	---	---	2.07E-04
Y-90	8.69E-08	---	2.33E-09	---	---	---	1.20E-04
Y-91M	8.10E-10	---	2.76E-11	---	---	---	2.70E-06
Y-91	1.13E-06	---	3.01E-08	---	---	---	8.10E-05
Y-92	7.65E-09	---	2.15E-10	---	---	---	1.46E-04
Y-93	2.43E-08	---	6.62E-10	---	---	---	1.92E-04
Zr-95	2.06E-07	5.02E-08	3.56E-08	---	5.41E-08	---	2.50E-05
Zr-97	1.48E-08	2.54E-09	1.16E-09	---	2.56E-09	---	1.62E-04
Nb-95	4.20E-08	1.73E-08	1.00E-08	---	1.24E-08	---	1.46E-05
Mo-99	---	3.40E-05	6.63E-06	---	5.08E-05	---	1.12E-05
Tc-99M	1.92E-09	3.96E-09	5.10E-08	---	4.26E-08	2.07E-09	1.15E-06

Table 16 - Ingestion Dose Factors for Infant
(mrem per pCi Ingested)

Nuclide	Bone	Liver	T. Body	Thyroid	Kidney	Lung	GI-LLI
Tc-101	2.27E-09	2.86E-09	2.83E-08	---	3.40E-08	1.56E-09	4.86E-07
Ru-103	1.48E-06	---	4.95E-07	---	3.08E-06	---	1.80E-05
Ru-105	1.36E-07	---	4.58E-08	---	1.00E-06	---	5.41E-05
Ru-106	2.41E-05	---	3.01E-06	---	2.85E-05	---	1.83E-04
Ag-110M	9.96E-07	7.27E-07	4.81E-07	---	1.04E-06	---	3.77E-05
Sb-124	2.14E-05	3.15E-07	6.63E-06	5.68E-08	---	1.34E-05	6.60E-05
Sb-125	1.23E-05	1.19E-07	2.53E-06	1.54E-08	---	7.12E-06	1.64E-05
Te-125M	2.33E-05	7.79E-06	3.15E-06	7.84E-06	---	---	1.11E-05
Te-127M	5.85E-05	1.94E-05	7.08E-06	1.69E-05	1.44E-04	---	2.36E-05
Te-127	1.00E-06	3.35E-07	2.15E-07	8.14E-07	2.44E-06	---	2.10E-05
Te-129M	1.00E-04	3.43E-05	1.54E-05	3.84E-05	2.50E-04	---	5.97E-05
Te-129	2.84E-07	9.79E-08	6.63E-08	2.38E-07	7.07E-07	---	2.27E-05
Te-131M	1.52E-05	6.12E-06	5.05E-06	1.24E-05	4.21E-05	---	1.03E-04
Te-131	1.76E-07	6.50E-08	4.94E-08	1.57E-07	4.50E-07	---	7.11E-06
Te-132	2.08E-05	1.03E-05	9.61E-06	1.52E-05	6.44E-05	---	3.81E-05
I-130	6.00E-06	1.32E-05	5.30E-06	1.48E-03	1.45E-05	---	2.83E-06
I-131	3.59E-05	4.23E-05	1.86E-05	1.39E-02	4.94E-05	---	1.51E-06
I-132	1.66E-06	3.37E-06	1.20E-06	1.58E-04	3.76E-06	---	2.73E-06
I-133	1.25E-05	1.82E-05	5.33E-06	3.31E-03	2.14E-05	---	3.08E-06
I-134	8.69E-07	1.78E-06	6.33E-07	4.15E-05	1.99E-06	---	1.84E-06
I-135	3.64E-06	7.24E-06	2.64E-06	6.49E-04	8.07E-06	---	2.62E-06
Cs-134	3.77E-04	7.03E-04	7.10E-05	---	1.81E-04	7.42E-05	1.91E-06
Cs-136	4.59E-05	1.35E-04	5.04E-05	---	5.38E-05	1.10E-05	2.05E-06
Cs-137	5.22E-04	6.11E-04	4.33E-05	---	1.64E-04	6.64E-05	1.91E-06
Cs-138	4.81E-07	7.82E-07	3.79E-07	---	3.90E-07	6.09E-08	1.25E-06
Ba-139	8.81E-07	5.84E-10	2.55E-08	---	3.51E-10	3.54E-10	5.58E-05
Ba-140	1.71E-04	1.71E-07	8.81E-06	---	4.06E-08	1.05E-07	4.20E-05
Ba-141	4.25E-07	2.91E-10	1.34E-08	---	1.75E-10	1.77E-10	5.19E-06
Ba-142	1.84E-07	1.53E-10	9.06E-09	---	8.81E-11	9.26E-11	7.59E-07
La-140	2.11E-08	8.32E-09	2.14E-09	---	---	---	9.77E-05
La-142	1.10E-09	4.04E-10	9.67E-11	---	---	---	6.86E-05
Ce-141	7.87E-08	4.80E-08	5.65E-09	---	1.48E-08	---	2.48E-05
Ce-143	1.48E-08	9.82E-06	1.12E-09	---	2.86E-09	---	5.73E-05
Ce-144	2.98E-06	1.22E-06	1.67E-07	---	4.93E-07	---	1.71E-04
Pr-143	8.13E-08	3.04E-08	4.03E-09	---	1.13E-08	---	4.29E-05
Pr-144	2.74E-10	1.06E-10	1.38E-11	---	3.84E-11	---	4.93E-06
Nd-147	5.53E-08	5.68E-08	3.48E-09	---	2.19E-08	---	3.60E-05

Table 16 - Ingestion Dose Factors for Infant
(mrem per pCi Ingested)

Nuclide	Bone	Liver	T. Body	Thyroid	Kidney	Lung	GI-LLI
W-187	9.03E-07	6.28E-07	2.17E-07	---	---	---	3.69E-05
Pu-238	1.28E-03	1.50E-04	3.40E-05	---	1.21E-04	---	7.57E-05
Pu-239	1.38E-03	1.55E-04	3.54E-05	---	1.28E-04	---	6.91E-05
Pu-240	1.38E-03	1.55E-04	3.54E-05	---	1.28E-04	---	7.04E-05
Pu-241	4.25E-05	1.76E-06	8.82E-07	---	3.17E-06	---	1.45E-06
Np-239	1.11E-08	9.93E-10	5.61E-10	---	1.98E-09	---	2.87E-05
Am-241	1.46E-03	1.27E-03	1.09E-04	---	6.55E-04	---	7.70E-05
Cm-242	1.37E-04	1.27E-04	9.10E-06	---	2.62E-05	---	8.23E-05
Cm-243	1.40E-03	1.15E-03	8.98E-05	---	3.27E-04	---	8.10E-05
Cm-244	1.18E-03	9.70E-04	7.59E-05	---	2.71E-04	---	7.84E-05

Table 17 - Recommended Values for Other Parameters

Parameter Symbol	Definition	Values
f_g	Fraction of ingested produce grown in garden of interest.	0.76
f_p	Fraction of leafy vegetables grown in garden of interest.	1.0
P	Effective surface density of soil (assumes a 15 cm plow layer, expressed in dry weight)	240 kg/m ²
r	Fraction of deposited activity retained on crops, leafy vegetables, or pasture grass	0.25 1.0 (iodines) 0.2 (other particulates)
S_r	Attenuation factor accounting for shielding provided by residential structures	0.7 (maximum individual) 0.5 (general population)
t_b	Period of long-term buildup for activity in sediment or soil (20 years)	1.752E5 hr
t_e	Period of crop, leafy vegetable, or pasture grass exposure during growing season	30 days (grass-cow-milk-man pathway) 60 days (crop/vegetation-man pathway)
t_r	Transport time from animal feed-milk-man provided by residential structures	2 days (maximum individual) 4 days (general population)
t_h	Time delay between harvest of vegetation or crops and ingestion:	
	• For ingestion of forage by animals	Zero (pasture grass) 90 days (stored feed)
	• For ingestion of crops by man	1 day (leafy vegetables and max. individual feed) 60 days (produce and max. individual) 14 days (general population)
f_s	The fraction of daily feed that is pasture grass while the animals graze on pasture.	1.0
M_p	The mixing ratio at the point of withdrawal of drinking water.	Site Discharge 7.14 M.U.D. Intake 30.8
f_p	Fraction of the year that animals graze on pasture.	0.5

Table 17 - Recommended Values for Other Parameters

Parameter Symbol	Definition	Values
t_p	Environmental transit time, release to receptor (add time from release to exposure individual point to minimums shown for distribution)	12 hrs. (maximum) 1 day (maximum individual) 1 day (general population) 7 days (population--sport fish doses) 10 days (population--commercial fish doses)
t_s	Average time from slaughter of meat animal to consumption	20 days
Y_v	Agricultural productivity by unit area (measured in wet weight)	0.7 kg/m ² (grass-cow-milk-man pathway) 2.0 kg/m ² (produce or leafy vegetable ingested by man)
W	Shore-width factor for river shoreline	0.2
λ_w	Rate constant for removal of activity on plant or leaf structures by weathering (corresponds to a 14-day half-life)	0.0021 hr ⁻¹



Radwaste Process Control Program

Revision 0

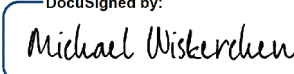
Authored By:  DocuSigned by: 12/8/2020 | 9:13 AM CST
98713CBA50A74B4... _____
 Michael Wiskerchen, FCS Waste Manager Date

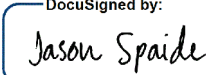
Reviewed By:  DocuSigned by: 12/9/2020 | 8:26 AM CST
CF69BC7E17874F9... _____
 Jason Spaide, FCS Manager of Special Projects Date

Approved By:  DocuSigned by: 12/9/2020 | 9:55 AM CST
364EA3DD3253414... _____
 Joseph Nowak, FCS Project Director Date

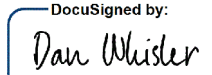
Approved By:  DocuSigned by: 12/9/2020 | 10:34 AM CST
2643AC68743D4A4... _____
 Dan Whisler, OPPD/FCS Radiation Protection Manager Date

Approved By:  DocuSigned by: 12/9/2020 | 12:03 PM CST
E391699A3B234B3... _____
 Independent Safety Reviewer Andrea Barker Date

- Non-Proprietary
- Proprietary
- Restricted Information
- Safeguards Information
- Sensitive Security Information

- New
- Title Change
- Revision
- Rewrite
- Cancellation

Effective Date: _____

RECORD OF REVISIONS

Revision	Revision Title Description and Reason for Change
0	Initial issue. New document.

Table of Contents

1 PURPOSE AND SCOPE..... 4

1.1 Purpose..... 4

1.2 Scope..... 4

2 REFERENCES..... 4

3 GENERAL..... 5

3.1 Definitions..... 5

3.2 Responsibilities..... 5

3.3 Precautions and Limitations 5

3.4 Records..... 5

4 REQUIREMENTS AND GUIDANCE 5

4.1 General Instructions 5

4.2 Administrative Controls..... 7

5 ATTACHMENTS AND FORMS 7

1 PURPOSE AND SCOPE

1.1 Purpose

1.1.1 The purpose of this document is to establish a Process Control Program that ensures processing and packaging of solid radioactive waste resulting from treatment of gaseous and liquid effluents and from other sources that is compliant with:

- A. Applicable federal and state regulations
- B. Disposal site requirements
- C. Other requirements governing the disposal of radioactive waste

1.2 Scope

1.2.1 The scope of this document applies to all personnel performing activities associated with the processing and packaging of solid radioactive waste.

2 REFERENCES

- 2.1 10 CFR Part 20, Standards for Protection Against Radiation
- 2.2 10 CFR Part 50, Appendix A, General Design Criteria 60, Control of Releases of Radioactive Material to the Environment
- 2.3 10 CFR Part 50.36a, Technical Specifications on Effluents from Nuclear Power Reactors
- 2.4 10 CFR Part 61, Licensing Requirements for Land Disposal of Radioactive Waste
- 2.5 10 CFR Part 71, Packaging and Transportation of Radioactive Materials
- 2.6 49 CFR, Transportation
- 2.7 NUREG 1301, Offsite Dose Calculation Manual Guidance: Standard Radiological Effluent Controls for Pressurized Water Reactors, U.S. Nuclear Regulatory Commission, April 1991
- 2.8 NRC Generic Letter 89-01, Implementation of Programmatic Controls for Radiological Effluent Technical Specifications and the Relocation of Procedural Details of RETs to the Offsite Dose Calculation Manual or to the Process Control Program, January 31, 1989
- 2.9 USNRC Low-Level Waste Licensing Branch Technical Position on Radioactive Waste Form, Rev. 1, January, 1991
- 2.10 FCSD-CH-108, Annual Radioactive Effluent Release Report
- 2.11 FCSD-RW-PR-308, Packaging Solid Radioactive Waste
- 2.12 EPND-RM-100, Records Management Program
- 2.13 FCSD-RW-PG-100, Waste Management Program
- 2.14 NO-FC-10, Quality Assurance Topical Report (QATR)

- 2.15 EnergySolutions, Utah Department of Environmental Quality, Division of Radiation Control, Radioactive Material License, License Number UT 2300249

3 GENERAL

3.1 Definitions

None

3.2 Responsibilities

- 3.2.1 The Waste Manager has overall responsibility for solid radioactive waste activities at the D&D project site.
- 3.2.2 Contractors and their subcontractors have the roles and associated responsibilities of a vendor in accordance with this procedure.
- 3.2.3 Radiation Protection Manager has the responsibility of review and approval of the vendor submittals.

3.3 Precautions and Limitations

- 3.3.1 Verify current revision in accordance with applicable site procedures.

3.4 Records

- 3.4.1 All Waste Management records will be maintained in accordance with FCSD-RW-PG-100 (Ref. 2.13).
- 3.4.2 Records generated from the use of this procedure should be processed in accordance with EPND-RM-100 (Ref. 2.12).

4 REQUIREMENTS AND GUIDANCE

4.1 General Instructions

4.1.1 Wet Waste

A. Process liquid wet waste in accordance with:

1. Specific site procedures that provide sufficient instructions for safe and efficient processing, immobilizing and, stabilizing of wet wastes in accordance with FCSD-RW-PR-308 (Ref. 2.11).
2. Shipment and disposal requirements that meet the criteria on Free Standing Water (FSW) in accordance with USNRC Low-Level Waste Licensing Branch Technical Position on Radioactive Waste Form (Ref. 2.9) and EnergySolutions, Utah Department of Environmental Quality, Division of Radiation Control, Radioactive Material License (Ref. 2.15).
3. Approved procedures that contain provisions for correcting processed waste in which FSW is detected in excess of FSW limits and criteria.

- B. Ensure vendor procedures are approved by the Radiation Protection Manager (RPM) prior to use.

4.1.2 Solidification

- A. Qualified vendors shall supply solidification Process Control Programs (PCPs), procedures, and topical reports to the RPM for approval.
- B. These documents should include:
 1. Process description
 2. Solidification media used
 3. Process control parameters
 4. Parameter boundary conditions
 5. Waste form properties
 6. Specific instructions to ensure systems are operated within process parameters
 7. Pre-solidification laboratory sample mixing criteria
 8. Sampling frequency and acceptance criteria
 9. Exothermic reaction process control parameters
- C. Solidification vendor documentation shall include provisions to verify FSW criteria are met for the specific waste type being solidified.
- D. The vendor supplied PCP shall contain the current formulas, sampling, analyses, tests, and determinations to be made to ensure that processing and packaging of solid radioactive wastes based on demonstrated processing of actual or simulated wet solid wastes will be accomplished in such a way as to assure compliance with 10 CFR Parts 20, 61 and 71 (Refs. 2.1, 2.4, 2.5), state regulations, burial ground requirements, and other requirements governing the disposal of solid radioactive waste.

4.1.3 Containers, Shipping Casks, and Packaging

- A. Solid radioactive waste shall be processed, packaged and shipped in accordance with approved site procedures.
- B. Procedures shall provide specific instructions that ensure compliance with applicable federal, state and burial site requirements.

4.1.4 Shipping and Disposal

- A. Prepare, load and ship solid radioactive waste in accordance with specific site procedures to meet federal, state, and burial site requirements.

4.1.5 Oily/Mixed Wastes

- A. Radioactive wastes containing oil or hazardous substances are processed in accordance with approved site procedures to ensure compliance with applicable requirements.

4.1.6 Special Cases

- A. Unique wastes may require special techniques or processes. Process special case waste in accordance with specific site procedures to meet applicable requirements.
- B. Implementing procedures are reviewed and approved by the Waste Manager.
- C. Special processes developed under this provision should be documented as a change to the PCP per Section 4.2.2 of this procedure.

4.2 Administrative Controls

4.2.1 Quality Assurance

- A. Quality Assurance shall be implemented in a graded approach as described in NO-FC-10 (Ref. 2.14).

4.2.2 Changes to the Process Control Programs (PCPs)

- A. Licensee-initiated changes to the PCP shall:
 - 1. Be documented and records of reviews shall be retained in accordance with NO-FC-10 (Ref. 2.14). This documentation shall contain:
 - i. Sufficient information to support the change(s), together with the appropriate analyses or evaluations justifying the change(s),
 - ii. A determination that the change(s) will maintain the overall conformance of the solidified waste product to the existing requirements of federal, state and other applicable regulations, and
 - iii. Documentation that the change has been reviewed and found acceptable through execution of the applicable regulatory review process for the project.
 - 2. Changes made to the PCP shall be communicated to Chemistry and Environmental for inclusion in Annual Radioactive Effluent Release Report in accordance with FCSD-CH-108 (Ref. 2.10).

5 ATTACHMENTS AND FORMS

None

SECTION VII

ATTACHMENT 2

JOINT FREQUENCY DISTRIBUTION WIND DIRECTION VS. WIND SPEED
BY STABILITY CLASS AND METEOROLOGICAL DATA

(Regulatory Guide 1.21)

January 1, 2020 - December 31, 2020

JOINT FREQUENCY DISTRIBUTION WIND DIRECTION VS. WIND SPEED BY STABILITY CLASS AND METEOROLOGICAL DATA

A. Meteorological Data Recovery

Data availability from the on-site weather tower for the period January 1, 2015 through December 31, 2019 had a cumulative recovery rate of 78.15% from the meteorological tower with the remaining 21.85% provided by Eppley Airfield Weather Station, a branch of the National Weather Service. The following table is a summary of the parameters and their respective recovery rates for the period.

The tabulations of the Weather Tower Data for the period January 1, 2015 through December 31, 2019 look appropriate for the season indicated. The Pasquill Classes observed for the five year period are detailed below.

Pasquill								
Class	A	B	C	D	E	F	G	Total
% Obs.	7.34	3.46	6.37	46.83	22.95	8.56	4.49	100

On the basis of the data and its cross-checks, the weather data as amended is completely valid for use in tabulating atmospheric releases.

Omaha Public Power District
Fort Calhoun Nuclear Station
JOINT FREQUENCY DISTRIBUTION BY EVENTS
EXTREMELY UNSTABLE ($\Delta T / \Delta z \leq -1.9$)
PERIOD OF RECORD: JAN 2015 - DEC 2019
PASQUILL A
WIND SPEED (m/s) AT 10-m LEVEL

Wind Direct	< 0.5	0.5- 1.0	1.1- 1.5	1.6- 2.0	2.1- 3.0	3.1- 4.0	4.1- 5.0	5.1- 6.0	6.1- 8.0	8.1- 10.0	> 10.0	Total
N	0	3	19	31	76	97	56	14	13	0	0	309
NNE	1	6	22	20	22	23	6	5	0	0	0	105
NE	0	5	13	5	16	21	8	1	0	0	0	69
ENE	0	5	13	12	18	23	6	0	1	0	0	78
E	0	1	14	11	25	21	7	1	3	0	0	83
ESE	0	2	5	15	34	50	14	7	9	1	0	137
SE	0	2	9	12	21	24	33	18	22	3	1	145
SSE	0	3	3	8	29	34	39	33	53	9	0	211
S	0	1	3	5	19	44	27	26	42	10	2	179
SSW	1	1	4	3	21	32	24	17	30	10	1	144
SW	0	0	4	5	25	20	28	14	12	8	0	116
WSW	0	1	9	6	17	3	3	2	9	0	0	50
W	1	5	6	27	32	17	15	3	5	2	0	113
WNW	0	10	15	27	62	37	26	8	6	0	0	191
NW	0	9	17	15	73	94	122	68	71	12	5	486
NNW	0	6	18	30	146	173	184	126	88	15	4	790
Total	3	60	174	232	636	713	598	343	364	70	13	3206

Number of Calms 9
Number of Invalid Hours 0
Number of Valid Hours 3215

Omaha Public Power District
Fort Calhoun Nuclear Station
JOINT FREQUENCY DISTRIBUTION BY EVENTS
MODERATELY UNSTABLE ($-1.9 < \Delta T / \Delta z \leq -1.7$)
PERIOD OF RECORD: JAN 2015 - DEC 2019
PASQUILL B
WIND SPEED (m/s) AT 10-m LEVEL

Wind Direct	< 0.5	0.5- 1.0	1.1- 1.5	1.6- 2.0	2.1- 3.0	3.1- 4.0	4.1- 5.0	5.1- 6.0	6.1- 8.0	8.1- 10.0	> 10.0	Total
N	0	15	18	23	52	28	12	4	2	0	0	154
NNE	0	4	10	10	16	4	4	0	0	0	0	48
NE	0	2	8	13	14	8	3	2	0	0	0	50
ENE	0	1	5	14	20	10	7	3	0	0	0	60
E	0	3	4	11	26	12	3	3	0	0	0	62
ESE	0	2	5	3	16	10	12	6	3	2	0	59
SE	0	1	1	7	9	29	31	29	15	2	0	124
SSE	0	5	3	7	4	17	30	15	22	2	0	105
S	0	0	2	6	16	23	23	12	19	8	1	110
SSW	0	3	2	4	8	10	10	13	18	3	0	71
SW	1	2	2	3	11	9	4	2	4	0	0	38
WSW	0	1	4	5	10	5	4	1	1	1	0	32
W	0	0	5	10	7	5	4	1	5	0	0	37
WNW	0	2	6	7	31	9	7	1	6	1	0	70
NW	0	3	9	7	23	27	30	21	18	3	1	142
NNW	0	2	14	21	85	80	57	42	29	4	0	334
Total	1	46	98	151	348	286	241	155	142	26	2	1496

Number of Calms 19
Number of Invalid Hours 0
Number of Valid Hours 1515

Omaha Public Power District
Fort Calhoun Nuclear Station
JOINT FREQUENCY DISTRIBUTION BY EVENTS
SLIGHTLY UNSTABLE ($-1.7 < \Delta T / \Delta z \leq -1.5$)
PERIOD OF RECORD: JAN 2015 - DEC 2019
PASQUILL C
WIND SPEED (m/s) AT 10-m LEVEL

Wind Direct	< 0.5	0.5- 1.0	1.1- 1.5	1.6- 2.0	2.1- 3.0	3.1- 4.0	4.1- 5.0	5.1- 6.0	6.1- 8.0	8.1- 10.0	> 10.0	Total
N	1	39	56	75	71	56	24	6	2	0	0	330
NNE	0	13	30	32	29	9	2	2	0	0	0	117
NE	0	7	13	16	22	12	2	1	1	0	0	74
ENE	0	7	14	18	28	16	7	2	0	0	0	92
E	0	11	17	28	26	8	7	2	1	0	0	100
ESE	0	11	15	19	28	21	15	7	7	1	0	124
SE	0	15	26	42	37	38	36	29	16	3	1	243
SSE	0	15	25	36	25	34	32	28	34	10	0	239
S	0	11	16	21	38	48	31	18	16	5	2	206
SSW	0	6	5	23	21	18	17	16	22	3	1	132
SW	0	6	12	11	13	19	14	6	5	3	1	90
WSW	0	3	5	14	11	10	5	5	2	0	0	55
W	0	9	17	20	21	13	4	2	6	1	0	93
WNW	0	6	13	19	24	19	12	5	6	0	0	104
NW	0	8	19	25	45	44	32	23	27	7	0	230
NNW	0	8	27	59	84	102	57	35	30	9	4	415
Total	1	175	310	458	523	467	297	187	175	42	9	2644

Number of Calms 146
Number of Invalid Hours 0
Number of Valid Hours 2790

Omaha Public Power District
Fort Calhoun Nuclear Station
JOINT FREQUENCY DISTRIBUTION BY EVENTS
NEUTRAL (-1.5 < delta T/ delta z <= -0.5)
PERIOD OF RECORD: JAN 2015 - DEC 2019
PASQUILL D
WIND SPEED (m/s) AT 10-m LEVEL

Wind Direct	< 0.5	0.5- 1.0	1.1- 1.5	1.6- 2.0	2.1- 3.0	3.1- 4.0	4.1- 5.0	5.1- 6.0	6.1- 8.0	8.1- 10.0	> 10.0	Total
N	2	88	181	341	605	475	168	94	47	0	0	2001
NNE	2	58	142	148	194	145	47	15	7	1	0	759
NE	2	40	106	111	135	69	38	15	7	3	0	526
ENE	0	37	131	108	153	92	37	13	13	0	0	584
E	1	38	112	159	265	148	58	23	10	2	0	816
ESE	1	45	86	170	301	222	85	39	34	8	1	992
SE	2	31	78	197	497	464	296	174	129	18	6	1892
SSE	2	25	53	164	522	655	497	340	342	34	8	2642
S	1	24	42	101	309	490	453	339	316	66	9	2150
SSW	1	18	32	61	168	200	164	153	151	34	12	994
SW	2	12	37	43	177	139	83	56	50	14	4	617
WSW	1	25	39	48	96	83	48	26	17	2	0	385
W	1	25	39	91	147	112	55	49	36	9	0	564
WNW	6	37	69	72	175	163	111	58	50	2	0	743
NW	3	39	89	113	281	337	302	189	216	48	7	1624
NNW	2	49	171	269	816	768	462	239	209	26	1	3012
Total	29	591	1407	2196	4841	4562	2904	1822	1634	267	48	20301

Number of Calms 212
Number of Invalid Hours 0
Number of Valid Hours 20513

Omaha Public Power District
Fort Calhoun Nuclear Station
JOINT FREQUENCY DISTRIBUTION BY EVENTS
SLIGHTLY STABLE ($-0.5 < \Delta T / \Delta z \leq 1.5$)
PERIOD OF RECORD: JAN 2015 - DEC 2019
PASQUILL E
WIND SPEED (m/s) AT 10-m LEVEL

Wind Direct	< 0.5	0.5- 1.0	1.1- 1.5	1.6- 2.0	2.1- 3.0	3.1- 4.0	4.1- 5.0	5.1- 6.0	6.1- 8.0	8.1- 10.0	> 10.0	Total
N	10	55	78	55	81	31	9	2	0	0	0	321
NNE	6	60	46	29	42	6	4	0	1	0	0	194
NE	10	46	64	33	29	3	1	0	0	0	0	186
ENE	5	47	64	35	44	9	5	1	0	0	0	210
E	9	50	79	64	85	22	8	3	2	0	0	322
ESE	8	47	142	131	163	44	14	8	5	0	0	562
SE	10	59	157	206	452	288	131	43	48	6	2	1402
SSE	10	52	76	136	462	370	262	113	67	5	0	1553
S	6	41	42	60	198	250	221	123	88	9	1	1039
SSW	11	45	45	21	74	80	123	95	140	29	4	667
SW	26	39	26	21	45	43	32	43	84	31	6	396
WSW	11	47	37	33	51	46	37	15	15	2	1	295
W	25	86	64	70	104	70	45	18	10	1	1	494
WNW	22	172	142	93	212	103	56	13	9	2	0	824
NW	11	113	158	132	191	108	34	4	6	0	1	758
NNW	13	70	142	168	271	113	26	13	10	1	0	827
Total	193	1029	1362	1287	2504	1586	1008	494	485	86	16	10050

Number of Calms 0
Number of Invalid Hours 0
Number of Valid Hours 10050

Omaha Public Power District
Fort Calhoun Nuclear Station
JOINT FREQUENCY DISTRIBUTION BY EVENTS
MODERATELY STABLE ($1.5 < \Delta T / \Delta z \leq 4.0$)
PERIOD OF RECORD: JAN 2015 - DEC 2019
PASQUILL F
WIND SPEED (m/s) AT 10-m LEVEL

Wind Direct	< 0.5	0.5- 1.0	1.1- 1.5	1.6- 2.0	2.1- 3.0	3.1- 4.0	4.1- 5.0	5.1- 6.0	6.1- 8.0	8.1- 10.0	> 10.0	Total
N	8	24	21	27	17	4	1	0	0	0	0	102
NNE	8	27	12	10	1	0	0	0	0	0	0	58
NE	11	22	5	2	0	1	0	0	0	0	0	41
ENE	5	41	26	6	4	0	0	0	0	0	1	83
E	9	59	57	24	22	2	0	0	0	0	0	173
ESE	10	50	101	70	41	21	2	0	0	0	0	295
SE	14	81	124	122	164	62	25	7	0	0	0	599
SSE	23	78	59	96	160	35	4	1	0	0	0	456
S	26	76	24	35	81	52	23	4	1	0	0	322
SSW	39	72	31	15	29	37	27	8	1	0	0	259
SW	36	81	14	11	19	13	15	9	9	2	0	209
WSW	37	77	17	6	9	16	9	0	3	0	0	174
W	38	125	39	25	17	6	1	0	0	0	0	251
WNW	32	129	90	34	44	12	1	0	0	0	0	342
NW	16	54	43	23	25	6	0	0	0	0	0	167
NNW	9	22	21	26	31	12	3	3	3	1	0	131
Total	321	1018	684	532	664	279	111	32	17	3	1	3662

Number of Calms 86
Number of Invalid Hours 0
Number of Valid Hours 3748

Omaha Public Power District
Fort Calhoun Nuclear Station
JOINT FREQUENCY DISTRIBUTION BY EVENTS
EXTREMELY STABLE ($\Delta T / \Delta z > 4.0$)
PERIOD OF RECORD: JAN 2015 - DEC 2019
PASQUILL G
WIND SPEED (m/s) AT 10-m LEVEL

Wind Direct	< 0.5	0.5- 1.0	1.1- 1.5	1.6- 2.0	2.1- 3.0	3.1- 4.0	4.1- 5.0	5.1- 6.0	6.1- 8.0	8.1- 10.0	> 10.0	Total
N	5	19	9	6	1	1	0	0	0	0	0	41
NNE	13	16	7	3	1	3	0	0	0	0	0	43
NE	13	31	2	1	1	3	0	0	0	0	0	51
ENE	18	49	13	4	1	0	0	1	2	0	0	88
E	20	50	26	9	2	0	0	1	0	0	0	108
ESE	26	87	165	34	8	5	0	0	0	0	0	325
SE	22	101	75	37	20	5	2	0	0	0	0	262
SSE	32	88	56	34	8	1	0	0	0	0	0	219
S	19	84	24	13	14	8	2	2	0	0	0	166
SSW	23	77	13	7	8	8	3	2	0	0	0	141
SW	23	81	7	2	6	6	4	1	0	0	0	130
WSW	24	36	10	3	1	1	0	0	0	0	0	75
W	18	38	13	7	3	0	0	0	0	0	0	79
WNW	6	24	15	7	0	0	0	0	0	0	0	52
NW	9	19	12	5	1	1	0	0	0	0	0	47
NNW	2	10	9	8	3	8	20	2	0	0	0	62
Total	273	810	456	180	78	50	31	9	2	0	0	1889

Number of Calms 79
Number of Invalid Hours 0
Number of Valid Hours 1968

Hours Accounted For: 43799

Omaha Public Power District
Fort Calhoun Nuclear Station
JOINT FREQUENCY DISTRIBUTION BY PERCENT
EXTREMELY UNSTABLE ($\Delta T / \Delta z \leq -1.9$)
PERIOD OF RECORD: JAN 2015 - DEC 2019
PASQUILL A
WIND SPEED (m/s) AT 10-m LEVEL

Wind Direct	< 0.5	0.5- 1.0	1.1- 1.5	1.6- 2.0	2.1- 3.0	3.1- 4.0	4.1- 5.0	5.1- 6.0	6.1- 8.0	8.1- 10.0	> 10.0	Total
N	0.00	0.01	0.04	0.07	0.17	0.22	0.13	0.03	0.03	0.00	0.00	0.71
NNE	0.00	0.01	0.05	0.05	0.05	0.05	0.01	0.01	0.00	0.00	0.00	0.24
NE	0.00	0.01	0.03	0.01	0.04	0.05	0.02	0.00	0.00	0.00	0.00	0.16
ENE	0.00	0.01	0.03	0.03	0.04	0.05	0.01	0.00	0.00	0.00	0.00	0.18
E	0.00	0.00	0.03	0.03	0.06	0.05	0.02	0.00	0.01	0.00	0.00	0.19
ESE	0.00	0.00	0.01	0.03	0.08	0.11	0.03	0.02	0.02	0.00	0.00	0.31
SE	0.00	0.00	0.02	0.03	0.05	0.05	0.08	0.04	0.05	0.01	0.00	0.33
SSE	0.00	0.01	0.01	0.02	0.07	0.08	0.09	0.08	0.12	0.02	0.00	0.48
S	0.00	0.00	0.01	0.01	0.04	0.10	0.06	0.06	0.10	0.02	0.00	0.41
SSW	0.00	0.00	0.01	0.01	0.05	0.07	0.05	0.04	0.07	0.02	0.00	0.33
SW	0.00	0.00	0.01	0.01	0.06	0.05	0.06	0.03	0.03	0.02	0.00	0.26
WSW	0.00	0.00	0.02	0.01	0.04	0.01	0.01	0.00	0.02	0.00	0.00	0.11
W	0.00	0.01	0.01	0.06	0.07	0.04	0.03	0.01	0.01	0.00	0.00	0.26
WNW	0.00	0.02	0.03	0.06	0.14	0.08	0.06	0.02	0.01	0.00	0.00	0.44
NW	0.00	0.02	0.04	0.03	0.17	0.21	0.28	0.16	0.16	0.03	0.01	1.11
NNW	0.00	0.01	0.04	0.07	0.33	0.39	0.42	0.29	0.20	0.03	0.01	1.80
Total	0.01	0.14	0.40	0.53	1.45	1.63	1.37	0.78	0.83	0.16	0.03	7.32

Percent of Calms 0.02
Percent of Invalid Hours 0.00
Percent of Valid Hours 7.34

Omaha Public Power District
Fort Calhoun Nuclear Station
JOINT FREQUENCY DISTRIBUTION BY PERCENT
MODERATELY UNSTABLE (-1.9 < delta T/ delta z <= -1.7)
PERIOD OF RECORD: JAN 2015 - DEC 2019
PASQUILL B
WIND SPEED (m/s) AT 10-m LEVEL

Wind Direct	< 0.5	0.5- 1.0	1.1- 1.5	1.6- 2.0	2.1- 3.0	3.1- 4.0	4.1- 5.0	5.1- 6.0	6.1- 8.0	8.1- 10.0	> 10.0	Total
N	0.00	0.03	0.04	0.05	0.12	0.06	0.03	0.01	0.00	0.00	0.00	0.35
NNE	0.00	0.01	0.02	0.02	0.04	0.01	0.01	0.00	0.00	0.00	0.00	0.11
NE	0.00	0.00	0.02	0.03	0.03	0.02	0.01	0.00	0.00	0.00	0.00	0.11
ENE	0.00	0.00	0.01	0.03	0.05	0.02	0.02	0.01	0.00	0.00	0.00	0.14
E	0.00	0.01	0.01	0.03	0.06	0.03	0.01	0.01	0.00	0.00	0.00	0.14
ESE	0.00	0.00	0.01	0.01	0.04	0.02	0.03	0.01	0.01	0.00	0.00	0.13
SE	0.00	0.00	0.00	0.02	0.02	0.07	0.07	0.07	0.03	0.00	0.00	0.28
SSE	0.00	0.01	0.01	0.02	0.01	0.04	0.07	0.03	0.05	0.00	0.00	0.24
S	0.00	0.00	0.00	0.01	0.04	0.05	0.05	0.03	0.04	0.02	0.00	0.25
SSW	0.00	0.01	0.00	0.01	0.02	0.02	0.02	0.03	0.04	0.01	0.00	0.16
SW	0.00	0.00	0.00	0.01	0.03	0.02	0.01	0.00	0.01	0.00	0.00	0.09
WSW	0.00	0.00	0.01	0.01	0.02	0.01	0.01	0.00	0.00	0.00	0.00	0.07
W	0.00	0.00	0.01	0.02	0.02	0.01	0.01	0.00	0.01	0.00	0.00	0.08
WNW	0.00	0.00	0.01	0.02	0.07	0.02	0.02	0.00	0.01	0.00	0.00	0.16
NW	0.00	0.01	0.02	0.02	0.05	0.06	0.07	0.05	0.04	0.01	0.00	0.32
NNW	0.00	0.00	0.03	0.05	0.19	0.18	0.13	0.10	0.07	0.01	0.00	0.76
Total	0.00	0.11	0.22	0.34	0.79	0.65	0.55	0.35	0.32	0.06	0.00	3.42

Percent of Calms 0.04
Percent of Invalid Hours 0.00
Percent of Valid Hours 3.46

Omaha Public Power District
Fort Calhoun Nuclear Station
JOINT FREQUENCY DISTRIBUTION BY PERCENT
SLIGHTLY UNSTABLE ($-1.7 < \Delta T / \Delta z \leq -1.5$)
PERIOD OF RECORD: JAN 2015 - DEC 2019
PASQUILL C
WIND SPEED (m/s) AT 10-m LEVEL

Wind Direct	< 0.5	0.5- 1.0	1.1- 1.5	1.6- 2.0	2.1- 3.0	3.1- 4.0	4.1- 5.0	5.1- 6.0	6.1- 8.0	8.1- 10.0	> 10.0	Total
N	0.00	0.09	0.13	0.17	0.16	0.13	0.05	0.01	0.00	0.00	0.00	0.75
NNE	0.00	0.03	0.07	0.07	0.07	0.02	0.00	0.00	0.00	0.00	0.00	0.27
NE	0.00	0.02	0.03	0.04	0.05	0.03	0.00	0.00	0.00	0.00	0.00	0.17
ENE	0.00	0.02	0.03	0.04	0.06	0.04	0.02	0.00	0.00	0.00	0.00	0.21
E	0.00	0.03	0.04	0.06	0.06	0.02	0.02	0.00	0.00	0.00	0.00	0.23
ESE	0.00	0.03	0.03	0.04	0.06	0.05	0.03	0.02	0.02	0.00	0.00	0.28
SE	0.00	0.03	0.06	0.10	0.08	0.09	0.08	0.07	0.04	0.01	0.00	0.55
SSE	0.00	0.03	0.06	0.08	0.06	0.08	0.07	0.06	0.08	0.02	0.00	0.55
S	0.00	0.03	0.04	0.05	0.09	0.11	0.07	0.04	0.04	0.01	0.00	0.47
SSW	0.00	0.01	0.01	0.05	0.05	0.04	0.04	0.04	0.05	0.01	0.00	0.30
SW	0.00	0.01	0.03	0.03	0.03	0.04	0.03	0.01	0.01	0.01	0.00	0.21
WSW	0.00	0.01	0.01	0.03	0.03	0.02	0.01	0.01	0.00	0.00	0.00	0.13
W	0.00	0.02	0.04	0.05	0.05	0.03	0.01	0.00	0.01	0.00	0.00	0.21
WNW	0.00	0.01	0.03	0.04	0.05	0.04	0.03	0.01	0.01	0.00	0.00	0.24
NW	0.00	0.02	0.04	0.06	0.10	0.10	0.07	0.05	0.06	0.02	0.00	0.53
NNW	0.00	0.02	0.06	0.13	0.19	0.23	0.13	0.08	0.07	0.02	0.01	0.95
Total	0.00	0.40	0.71	1.05	1.19	1.07	0.68	0.43	0.40	0.10	0.02	6.04

Percent of Calms 0.33
Percent of Invalid Hours 0.00
Percent of Valid Hours 6.37

Omaha Public Power District
Fort Calhoun Nuclear Station
JOINT FREQUENCY DISTRIBUTION BY PERCENT
NEUTRAL (-1.5 < delta T/ delta z <= -0.5)
PERIOD OF RECORD: JAN 2015 - DEC 2019
PASQUILL D
WIND SPEED (m/s) AT 10-m LEVEL

Wind Direct	< 0.5	0.5- 1.0	1.1- 1.5	1.6- 2.0	2.1- 3.0	3.1- 4.0	4.1- 5.0	5.1- 6.0	6.1- 8.0	8.1- 10.0	> 10.0	Total
N	0.00	0.20	0.41	0.78	1.38	1.08	0.38	0.21	0.11	0.00	0.00	4.57
NNE	0.00	0.13	0.32	0.34	0.44	0.33	0.11	0.03	0.02	0.00	0.00	1.73
NE	0.00	0.09	0.24	0.25	0.31	0.16	0.09	0.03	0.02	0.01	0.00	1.20
ENE	0.00	0.08	0.30	0.25	0.35	0.21	0.08	0.03	0.03	0.00	0.00	1.33
E	0.00	0.09	0.26	0.36	0.61	0.34	0.13	0.05	0.02	0.00	0.00	1.86
ESE	0.00	0.10	0.20	0.39	0.69	0.51	0.19	0.09	0.08	0.02	0.00	2.26
SE	0.00	0.07	0.18	0.45	1.13	1.06	0.68	0.40	0.29	0.04	0.01	4.32
SSE	0.00	0.06	0.12	0.37	1.19	1.50	1.13	0.78	0.78	0.08	0.02	6.03
S	0.00	0.05	0.10	0.23	0.71	1.12	1.03	0.77	0.72	0.15	0.02	4.91
SSW	0.00	0.04	0.07	0.14	0.38	0.46	0.37	0.35	0.34	0.08	0.03	2.27
SW	0.00	0.03	0.08	0.10	0.40	0.32	0.19	0.13	0.11	0.03	0.01	1.41
WSW	0.00	0.06	0.09	0.11	0.22	0.19	0.11	0.06	0.04	0.00	0.00	0.88
W	0.00	0.06	0.09	0.21	0.34	0.26	0.13	0.11	0.08	0.02	0.00	1.29
WNW	0.01	0.08	0.16	0.16	0.40	0.37	0.25	0.13	0.11	0.00	0.00	1.70
NW	0.01	0.09	0.20	0.26	0.64	0.77	0.69	0.43	0.49	0.11	0.02	3.71
NNW	0.00	0.11	0.39	0.61	1.86	1.75	1.05	0.55	0.48	0.06	0.00	6.88
Total	0.07	1.35	3.21	5.01	11.05	10.42	6.63	4.16	3.73	0.61	0.11	46.35

Percent of Calms 0.48
Percent of Invalid Hours 0.00
Percent of Valid Hours 46.83

Omaha Public Power District
Fort Calhoun Nuclear Station
JOINT FREQUENCY DISTRIBUTION BY PERCENT
SLIGHTLY STABLE (-0.5 < delta T/ delta z <= 1.5)
PERIOD OF RECORD: JAN 2015 - DEC 2019
PASQUILL E
WIND SPEED (m/s) AT 10-m LEVEL

Wind Direct	< 0.5	0.5- 1.0	1.1- 1.5	1.6- 2.0	2.1- 3.0	3.1- 4.0	4.1- 5.0	5.1- 6.0	6.1- 8.0	8.1- 10.0	> 10.0	Total
N	0.02	0.13	0.18	0.13	0.18	0.07	0.02	0.00	0.00	0.00	0.00	0.73
NNE	0.01	0.14	0.11	0.07	0.10	0.01	0.01	0.00	0.00	0.00	0.00	0.44
NE	0.02	0.11	0.15	0.08	0.07	0.01	0.00	0.00	0.00	0.00	0.00	0.42
ENE	0.01	0.11	0.15	0.08	0.10	0.02	0.01	0.00	0.00	0.00	0.00	0.48
E	0.02	0.11	0.18	0.15	0.19	0.05	0.02	0.01	0.00	0.00	0.00	0.74
ESE	0.02	0.11	0.32	0.30	0.37	0.10	0.03	0.02	0.01	0.00	0.00	1.28
SE	0.02	0.13	0.36	0.47	1.03	0.66	0.30	0.10	0.11	0.01	0.00	3.20
SSE	0.02	0.12	0.17	0.31	1.05	0.84	0.60	0.26	0.15	0.01	0.00	3.55
S	0.01	0.09	0.10	0.14	0.45	0.57	0.50	0.28	0.20	0.02	0.00	2.37
SSW	0.03	0.10	0.10	0.05	0.17	0.18	0.28	0.22	0.32	0.07	0.01	1.52
SW	0.06	0.09	0.06	0.05	0.10	0.10	0.07	0.10	0.19	0.07	0.01	0.90
WSW	0.03	0.11	0.08	0.08	0.12	0.11	0.08	0.03	0.03	0.00	0.00	0.67
W	0.06	0.20	0.15	0.16	0.24	0.16	0.10	0.04	0.02	0.00	0.00	1.13
WNW	0.05	0.39	0.32	0.21	0.48	0.24	0.13	0.03	0.02	0.00	0.00	1.88
NW	0.03	0.26	0.36	0.30	0.44	0.25	0.08	0.01	0.01	0.00	0.00	1.73
NNW	0.03	0.16	0.32	0.38	0.62	0.26	0.06	0.03	0.02	0.00	0.00	1.89
Total	0.44	2.35	3.11	2.94	5.72	3.62	2.30	1.13	1.11	0.20	0.04	22.95
Percent of Calms	0.00											
Percent of Invalid Hours	0.00											
Percent of Valid Hours	22.95											

Omaha Public Power District
Fort Calhoun Nuclear Station
JOINT FREQUENCY DISTRIBUTION BY PERCENT
MODERATELY STABLE (1.5 < delta T/ delta z <= 4.0)
PERIOD OF RECORD: JAN 2015 - DEC 2019
PASQUILL F
WIND SPEED (m/s) AT 10-m LEVEL

Wind Direct	< 0.5	0.5- 1.0	1.1- 1.5	1.6- 2.0	2.1- 3.0	3.1- 4.0	4.1- 5.0	5.1- 6.0	6.1- 8.0	8.1- 10.0	> 10.0	Total
N	0.02	0.05	0.05	0.06	0.04	0.01	0.00	0.00	0.00	0.00	0.00	0.23
NNE	0.02	0.06	0.03	0.02	0.00	0.00	0.00	0.00	0.00	0.00	0.00	0.13
NE	0.03	0.05	0.01	0.00	0.00	0.00	0.00	0.00	0.00	0.00	0.00	0.09
ENE	0.01	0.09	0.06	0.01	0.01	0.00	0.00	0.00	0.00	0.00	0.00	0.19
E	0.02	0.13	0.13	0.05	0.05	0.00	0.00	0.00	0.00	0.00	0.00	0.39
ESE	0.02	0.11	0.23	0.16	0.09	0.05	0.00	0.00	0.00	0.00	0.00	0.67
SE	0.03	0.18	0.28	0.28	0.37	0.14	0.06	0.02	0.00	0.00	0.00	1.37
SSE	0.05	0.18	0.13	0.22	0.37	0.08	0.01	0.00	0.00	0.00	0.00	1.04
S	0.06	0.17	0.05	0.08	0.18	0.12	0.05	0.01	0.00	0.00	0.00	0.74
SSW	0.09	0.16	0.07	0.03	0.07	0.08	0.06	0.02	0.00	0.00	0.00	0.59
SW	0.08	0.18	0.03	0.03	0.04	0.03	0.03	0.02	0.02	0.00	0.00	0.48
WSW	0.08	0.18	0.04	0.01	0.02	0.04	0.02	0.00	0.01	0.00	0.00	0.40
W	0.09	0.29	0.09	0.06	0.04	0.01	0.00	0.00	0.00	0.00	0.00	0.57
WNW	0.07	0.29	0.21	0.08	0.10	0.03	0.00	0.00	0.00	0.00	0.00	0.78
NW	0.04	0.12	0.10	0.05	0.06	0.01	0.00	0.00	0.00	0.00	0.00	0.38
NNW	0.02	0.05	0.05	0.06	0.07	0.03	0.01	0.01	0.01	0.00	0.00	0.30
Total	0.73	2.32	1.56	1.21	1.52	0.64	0.25	0.07	0.04	0.01	0.00	8.36

Percent of Calms 0.20
Percent of Invalid Hours 0.00
Percent of Valid Hours 8.56

Omaha Public Power District
Fort Calhoun Nuclear Station
JOINT FREQUENCY DISTRIBUTION BY PERCENT
EXTREMELY STABLE (delta T/ delta z > 4.0)
PERIOD OF RECORD: JAN 2015 - DEC 2019
PASQUILL G
WIND SPEED (m/s) AT 10-m LEVEL

Wind Direct	< 0.5	0.5- 1.0	1.1- 1.5	1.6- 2.0	2.1- 3.0	3.1- 4.0	4.1- 5.0	5.1- 6.0	6.1- 8.0	8.1- 10.0	> 10.0	Total
N	0.01	0.04	0.02	0.01	0.00	0.00	0.00	0.00	0.00	0.00	0.00	0.09
NNE	0.03	0.04	0.02	0.01	0.00	0.01	0.00	0.00	0.00	0.00	0.00	0.10
NE	0.03	0.07	0.00	0.00	0.00	0.01	0.00	0.00	0.00	0.00	0.00	0.12
ENE	0.04	0.11	0.03	0.01	0.00	0.00	0.00	0.00	0.00	0.00	0.00	0.20
E	0.05	0.11	0.06	0.02	0.00	0.00	0.00	0.00	0.00	0.00	0.00	0.25
ESE	0.06	0.20	0.38	0.08	0.02	0.01	0.00	0.00	0.00	0.00	0.00	0.74
SE	0.05	0.23	0.17	0.08	0.05	0.01	0.00	0.00	0.00	0.00	0.00	0.60
SSE	0.07	0.20	0.13	0.08	0.02	0.00	0.00	0.00	0.00	0.00	0.00	0.50
S	0.04	0.19	0.05	0.03	0.03	0.02	0.00	0.00	0.00	0.00	0.00	0.38
SSW	0.05	0.18	0.03	0.02	0.02	0.02	0.01	0.00	0.00	0.00	0.00	0.32
SW	0.05	0.18	0.02	0.00	0.01	0.01	0.01	0.00	0.00	0.00	0.00	0.30
WSW	0.05	0.08	0.02	0.01	0.00	0.00	0.00	0.00	0.00	0.00	0.00	0.17
W	0.04	0.09	0.03	0.02	0.01	0.00	0.00	0.00	0.00	0.00	0.00	0.18
WNW	0.01	0.05	0.03	0.02	0.00	0.00	0.00	0.00	0.00	0.00	0.00	0.12
NW	0.02	0.04	0.03	0.01	0.00	0.00	0.00	0.00	0.00	0.00	0.00	0.11
NNW	0.00	0.02	0.02	0.02	0.01	0.02	0.05	0.00	0.00	0.00	0.00	0.14
Total	0.62	1.85	1.04	0.41	0.18	0.11	0.07	0.02	0.00	0.00	0.00	4.31

Percent of Calms 0.18
Percent of Invalid Hours 0.00
Percent of Valid Hours 4.49

Percent of Hours Accounted For: 100.00

OMAHA PUBLIC POWER DISTRICT

FORT CALHOUN STATION

RADIOLOGICAL ENVIRONMENTAL OPERATING REPORT

January 01, 2020 – December 31, 2020

Annual Radiological Environmental Operating Report

This report is submitted for the period January 01, 2020 through December 31, 2020.

In addition, this report provides any observations and anomalies that occurred during the monitoring period.

Reviewed by:

DocuSigned by:
Ron Beck
58CD5329400C438...

RP/Chem Supervisor

Approved by:

DocuSigned by:
Dan Whisler
C91D0905920745F...

Manager-RP/Chemistry

DocuSigned by:
Ted Maine
7BF6365F747D40C...

Plant Manager Decommissioning

DocuSigned by:
Tim Uehling
00FAECAB8796489...

Senior Director of Nuclear Decommissioning

Annual Radiological Environmental Operating Report

The Fort Calhoun Station (FCS) Annual Radiological Environmental Operating Report for year 2020. The data provided is consistent with the objectives as specified in Section 6.2.2 of the Offsite Dose Calculation Manual (ODCM), "Annual Radiological Environmental Operating Report." The report is presented as follows:

- 1) An introductory discussion of the implementation of the Radiological Environmental Monitoring Program (REMP), including program observations and environmental impact relevant to the operation of FCS.
- 2) The sample class, sample collection frequency, number of sample locations, and the number of samples collected this reporting period for each parameter is delineated in Table 1.0.
- 3) A statistical evaluation of REMP data is summarized in Table 2.0, in accordance with Regulatory Guide 4.8, Table 1. For each type of sample media and analysis, Table 2.0 presents data separately for all **indicator** locations, all **control** (background) locations, and the location having the highest annual mean result. For each of these classes, Table 2.0 specifies the following:
 - a. The total number of analyses,
 - b. The fraction of analyses yielding detectable results (i.e., results above the highest Lower Limit of Detection (LLD) for this period),
 - c. The maximum, minimum, and average results,
 - d. Locations with the highest annual mean are specified by code, name, and by distance and direction from the center of plant reactor containment building.
- 4) Table 3.0 is a listing of missed samples and explanations
- 5) Table 4.0 is the 2020 Land Use Survey
- 6) Review of Environmental Inc. Quality Assurance Program
- 7) Appendix A describes the Interlaboratory Comparison Program
- 8) Appendix B describes the vendor Data Reporting Conventions utilized
- 9) Appendix C is the Sample Location Maps

INTRODUCTION

Radiological Environmental Monitoring Program (REMP) – 2020

This report gives the results of the Radiological Environmental Monitoring Program (REMP) for the year 2020. The REMP is a requirement of the Fort Calhoun Station (FCS) Quality Assurance Topical Report (QATR). It was initiated prior to plant operation in 1973.

The main purpose of the REMP is to ensure public safety by monitoring plant discharges and assessing the effect, if any, of plant operations on the environment. Samples are collected that would account for various exposure pathways such as ingestion, inhalation, adsorption and direct exposure. Samples collected on a regular basis include: air, surface water, ground water, milk, vegetation, fish, sediment, and food crops. Direct radiation is measured by thermoluminescent dosimeters (TLDs). These samples and TLDs are sent to an independent vendor laboratory for analysis. The vendor uses analytical methods that are sensitive enough to detect a level of activity far below that which would be considered harmful. Locations for sample collection are based on radiological and meteorological data from the Annual Effluent Release Report and information obtained from the Environmental Land Use Survey.

Most samples, particularly indicator samples, are collected in a circular area within a five-mile radius of plant containment. (However, control locations are usually outside of five miles.) This circle is divided into sixteen equal sectors, each assigned an identification letter "A" through "R" (note: letters "I" and "O" are not used, as they may be mistaken for the numbers "1" and "0"). Sector "A" is centered on North or zero degrees. Sectors are also given directional labels such as "West-Southwest" ("WSW"). Sample locations are listed by number along with their respective distances and direction from plant containment, in the Offsite Dose Calculation Manual (ODCM).

When assessing sample results, data from indicator locations (those most likely to be affected by plant operations) are compared to those from control locations (those least or not likely to be affected). Results from an indicator location which were significantly higher than those from a control location could indicate a plant-attributable effect and could require additional investigation.

The results of the sample analyses, as required by the FCS Offsite Dose Calculation Manual (ODCM), are presented in the attached statistical tables in accordance with Table 1 of Regulatory Guide 4.8, "Environmental Technical Specifications for Nuclear Power Plants." Sample collection was conducted by plant chemistry/environmental staff. A contract vendor (Environmental Inc., Northbrook, Illinois) performed sample analyses, preparation of monthly reports and the statistical evaluation of sample results. All vendor analysis techniques met the sensitivity requirements as stated in the ODCM.

Results for 2020 were within expected ranges and compared closely with historical results. The result details and exceptions are listed in the following sections.

1) Ambient Gamma Radiation

Ambient gamma radiation is measured by thermoluminescent dosimeters (TLDs) provided by the vendor laboratory. These dosimeters contain calcium sulfate phosphors and are processed quarterly.

One incident condition report was documented in the Corrective Action Program in 2020 related to TLD sampling. One TLD was lost and could not be located; TLD OTD-1F. The sample was added to Table 3.0 as a missed sample.

All sample results are within the range of historical data and displayed less than 10% difference when compared to historical averages. All results were less than 3 sigma standard deviations from historical means. No discrepancy between released effluents and resultant radiation dose measured was observed. No changes in plant operation/procedures are required based upon observed impacts to the environment to date.

Twelve TLD's were added to the station's ODCM. These TLD's were placed within the owner controlled area to assist with determination of 40 CFR 190 doses. These locations are not included in Table 1.0, but are being described to assist reviewers of vendor analysis records.

10-Year Trend Comparison of TLD Locations

Location	Avg. Dose (mr/week)	2020 Avg. Dose (mr/week)
A	1.30	1.35
B	1.40	1.43
C	1.33	1.33
D	1.17	1.08
F	1.33	1.23
G	1.30	1.25
H	1.32	1.28
I	1.46	1.53
J	1.52	1.45
K	1.42	1.38
N	1.48	1.48
O	1.45	1.45
P	1.49	1.35
S	1.54	1.65
L (Control)	1.26	1.28

2) Milk/Pasture

Milk samples or pasture grasses, if milk is temporarily unavailable, are collected every two weeks during the pasture season from the beginning of May through September, and monthly the rest of the calendar year. Indicator samples are collected from a herd of milk goats at a family farm located approximately 3.3 miles from the plant in Sector K (Southsouthwest). The control samples are collected from a commercial dairy cow herd located approximately 9.9 miles from the plant in Sector J (South). No indicator milk samples were available until spring (May) due to the dairy owners suspending operations. Pasture grass in lieu of milk was collected at the indicator location due to unavailability.

All sample results for Cesium-134, Cesium-137 and other gammas were at the LLD for both indicator and control locations. No plant-related effects were observed.

3) Fish

Fish are collected on an annual basis. Control samples are collected at a location approximately twenty miles upstream of the plant (river miles 665 – 667). Indicator samples are collected in the immediate vicinity of the power plant (river miles 644 – 646). Several species of fish, important to commercial and recreational interest, representing all levels of the aquatic food chain are collected at both locations.

All sample results are within the range of historical data. Results from both control and indicator locations were less than LLD for all gamma emitters, indicating no plant-related effects.

4) Food Crop

Based on the results of the biennial Land Use Survey, the nearest high deposition pathway for food crops is the Alvin Pechnik Farm in Sector H (0.94 miles, 163°). Accordingly, vegetable samples were collected at Alvin Pechnik Farm for the purposes of the 2020 REMP.

Samples were comparable with historical results and within the range of results reported from the control location garden at Mohr Dairy. The additional special interest sample was not obtained from on-site farm fields due to no crops being planted because of decommissioning, documented in CR 2021-00093. This sample is documented in Table 3.0.

All results were at the LLD for all non-naturally occurring radionuclides. No plant-related effects were observed.

5) Sediment

River sediment samples were deleted from the program due to shoreline sediment not being a significant pathway and reduced volume of effluent release and activity.

6) Air Monitoring

Air sample results for 2020 were well within historical limits for all locations. Additionally, all indicator locations showed results very similar to the control locations.

All sample results are within the range of historical data. All indicator locations displayed less than 21% difference when compared to historical average. All 2020 results when compared to historical averages are within the stated vendor error acceptance tolerance.

Results from both control and indicator locations were less than LLD for gamma emitters and iodine. No changes in plant operation/procedures are required based upon observed impacts to the environment to date.

10-Year Trend Comparison of Air Sampling Locations

Location	Avg. Beta (pCi/m ³)	2020 Avg. Beta (pCi/m ³)
Sector B	0.027	0.021
Sector D	0.027	0.026
Sector I	0.024	0.021
Sector J	0.024	0.021
Sector K	0.026	0.021
Sector F (Control)	0.027	0.025

7) Surface Water

Water samples are collected upstream of the plant (control location) as well as half-mile downstream and at a municipal water treatment plant on the north edge of Omaha.

Results for Cs-134, Cs-137, and other gammas were all less than LLD. All tritium results were less than LLD. No plant-related effects were detected.

8) Ground Water

Quarterly residential well water samples are collected at the following four locations: Station No. 15: Smith Farm, Station No. 20: Mohr Dairy, Station No. 74: D. Miller Farm and Station No. 75: Lomp Acreage. All sample results to date have been at the LLD except gross beta due to naturally occurring radionuclides. Gross beta results have ranged from a low of 2.0 pCi/liter to a high of 9.2 pCi/liter, with an average gross beta for the year of 4.5 pCi/liter for indicator locations. Strontium-90 analysis is being conducted on the wells as part of the station's groundwater protection program. No plant-related effects were detected.

Table 1.0

Sample Collection Program

Sample Class	Collection Frequency	Number of Sample Locations	Samples Collected this Period
Background Radiation (TLDs)	Quarterly	48 ⁴	187 ⁵
Air Particulates	Weekly	6	312
Airborne Iodine	Weekly ⁶	6	0
Milk	Biweekly May thru Sept	2	24 ¹
Surface Water	Monthly	3	36
Ground Water	Quarterly	4	16
Fish	Annually	2	5 ²
Sediment	Semi-annually	2	0 ⁷
Food Crops	Annually	2	9 ³
		TOTAL	589

Note 1: Milk sample collection total includes 4 vegetation samples performed for milk unavailability. Milk samples are collected every two weeks May-Sept. and monthly the rest of the year.

Note 2: Includes one background sample.

Note 3: Variety of samples collected during period

Note 4: Twelve sample locations were added for assessing 40 CFR 190 doses. The results are not included in REMP program totals.

Note 5: See table of missed samples for explanations.

Note 6: Collection was terminated on 1/9/19.

Note 7: Deleted from program.

Table 2 | Radiological Environmental Monitoring Program Summary

Reporting Period

January-December, 2020

Name of Facility Fort Calhoun Nuclear Power Station - Unit 1Docket No. 50-285Location of Facility Washington, Nebraska

(County, State)

Sample Type (Units)	Type and Number of Analyses ^a	LLD ^b	Indicator Locations Mean (F) ^c Range ^c	Location with Highest Annual Mean		Control Locations Mean (F) ^c Range ^c	Number Non-Routine Results ^a
				Location ^d	Mean (F) ^e Range ^c		
Background Radiation (TLD) (mR/week)	Gamma 239	0.5	1.4 (231/231) (0.9-2.0)	OTD-S-(I) 0.65 @ 163°	1.6 (4/4) 1.5-1.8 1.8 (1/1)	1.3 (4/4) (0.9-1.6)	0
Airborne Particulates (pCi/m ³)	GB 312	0.005	0.022 (260/260) (0.001-0.061)	OAP-D-(I) 3.0 mi. @ 303°	0.026 (52/52) (0.006-0.061)	0.025 (52/52) (0.011-0.050)	0
	GS 24			-	-	< LLD	0
	Cs-134	0.001	< LLD	-	-	< LLD	0
	Cs-137	0.001	< LLD	-	-	< LLD	0
Other Gammas	0.001	< LLD	-	-	< LLD	0	
Airborne Iodine (pCi/m ³)	I-131 0	0.07	< LLD	-	-	< LLD	0
Milk (pCi/L)	I-131 20	0.5	< LLD	-	-	< LLD	0
	GS 20						
	K-40	150	1720 (8/8) (1278-2012.1)	Miller Farm 0.8 mi. @ 206°	1720 (8/8) (1278-2012.1)	1340 (12/12) (1198-1502)	0
	Cs-134	15	< LLD	-	-	< LLD	0
	Cs-137	15	< LLD	-	-	< LLD	0
Other Gammas	15	< LLD	-	-	< LLD	0	
Ground Water (pCi/L)	GB 16		4.5 (12/12) (2.0-9.2)	Smith Farm 0.65 mi. @ 163°	5.3 (4/4) (3.8-9.2)	4.3 (4/4) (3.5-5.5)	0
	H-3 16	300	< LLD	-	-	< LLD	0
	Sr-90 16	0.7	< LLD	-	-	< LLD	0
	GS 16						
	Cs-134	15	< LLD	-	-	< LLD	0
	Cs-137	18	< LLD	-	-	< LLD	0
Other Gammas	15	< LLD	-	-	< LLD	0	
Surface Water (pCi/L)	GS 36						
	Cs-134	15	< LLD	-	-	< LLD	0
	Cs-137	18	< LLD	-	-	< LLD	0
	Other Gammas	15	< LLD	-	-	< LLD	0
H-3 12	300	< LLD	-	-	< LLD	0	

Table 2 | Radiological Environmental Monitoring Program Summary

Reporting Period

January-December, 2020Name of Facility
Location of FacilityFort Calhoun Nuclear Power Station - Unit 1
Washington, Nebraska
(County, State)

Docket No.

50-285

Sample Type (Units)	Type and Number of Analyses ^a	LLD ^b	Indicator Locations Mean (F) ^c Range ^c	Location with Highest Annual Mean		Control Locations Mean (F) ^c Range ^c	Number Non-Routine Results ^e
				Location ^d	Mean (F) ^c Range ^c		
Fish (pCi/g wet)	GS 5						
	Mn-54	0.022	< LLD	-	-	< LLD	0
	Co-58	0.041	< LLD	-	-	< LLD	0
	Co-60	0.015	< LLD	-	-	< LLD	0
	Fe-59	0.102	< LLD	-	-	< LLD	0
	Zn-65	0.043	< LLD	-	-	< LLD	0
	Ru-103	0.085	< LLD	-	-	< LLD	0
	Cs-134	0.021	< LLD	-	-	< LLD	0
Cs-137	0.020	< LLD	-	-	< LLD	0	
Sediment pCi/g dry	GS 0						
	Mn-54	0.000	< LLD	-	-	< LLD	0
	Co-58	0.000	< LLD	-	-	< LLD	0
	Co-60	0.000	< LLD	-	-	< LLD	0
	Fe-59	0.000	< LLD	-	-	< LLD	0
	Zn-65	0.000	< LLD	-	-	< LLD	0
	Cs-134	0.000	< LLD	-	-	< LLD	0
	Cs-137	0.000	< LLD	-	-	< LLD	0
Food Crops (pCi/g wet)	GS 9						
	Mn-54	0.012	< LLD	-	-	< LLD	0
	Co-58	0.014	< LLD	-	-	< LLD	0
	Co-60	0.011	< LLD	-	-	< LLD	0
	Fe-59	0.030	< LLD	-	-	< LLD	0
	Zn-65	0.030	< LLD	-	-	< LLD	0
	Zr-Nb-95	0.014	< LLD	-	-	< LLD	0
	Cs-134	0.018	< LLD	-	-	< LLD	0
	Cs-137	0.018	< LLD	-	-	< LLD	0
	Ba-La-140	0.015	< LLD	-	-	< LLD	0

^a GB = gross beta, GS = gamma scan.^b LLD = nominal lower limit of detection based on a 95% confidence level.^c Mean and range are based on detectable measurements only (i.e., >LLD) Fraction of detectable measurements at specified locations is indicated in parentheses (F).^d Locations are specified: (1) by code, (2) by name, and (3) by distance and direction relative to the Reactor Containment Building.^e Non-routine results are those which exceed ten times the control station value. If no control station value is available, the result is considered non-routine if it exceeds the typical pre-operational value for the medium or location.

Table 3.0 Listing of Missed Samples (samples scheduled but not collected)

Sample Type	Date	Location	Reason
TLD	1/7/2020	OTD-1F-(I)	Lost in field (CR 2020-00013)
VE	8/5/2020	O-OVG-E-(I)	No sample available. Corn not planted due to plant decommissioning. (CR 2021-00093)

Table 4.0 – 2020 Land Use Survey

FORT CALHOUN STATION
CHEMISTRY FORM

FC-801
REV 1
Page 1 of 3

2020 Environmental Land Use Survey Report

Sector	Dir	Land Use	Owner	Miles	Meters	Deg	Survey Technique	Age Group				XOQ	DOQ	Remarks
								Adult	Teen	Child	Infant			
A	N	RESIDENCE	WRIGHT	4.36	7016.74	351	INTERVIEW	X	X			1.30E-07	4.50E-10	
		MILK ANIMAL												
		MEAT ANIMAL												
		VEGETATION												
		GROUNDWATER	WRIGHT	4.36	7016.74	351	INTERVIEW	X	X					
B	NNE	RESIDENCE	RAND,J	1.93	3106.03	12	MAIL SURVEY	X				7.00E-07	1.90E-09	
		MILK ANIMAL												
		MEAT ANIMAL	DUGDALE,D	4.72	7596.10	29	INTERVIEW	X				1.10E-07	2.20E-10	
		VEGETATION	SHEPARD	2.23	3588.84	16	CITY REGISTER	X		X		4.60E-07	1.20E-09	
		GROUNDWATER	RAND,J	1.93	3106.03	12	MAIL SURVEY	X						
C	NE	RESIDENCE	HANSEN,M	1.52	2446.20	42	MAIL SURVEY	X		X		1.00E-06	2.20E-09	
		MILK ANIMAL												
		MEAT ANIMAL												
		VEGETATION	VENNER,R	3.20	5149.90	48	CITY REGISTER	X				1.70E-07	3.00E-10	
		GROUNDWATER	HANSEN,M	1.52	2446.20	42	MAIL SURVEY	X		X				
D	ENE	RESIDENCE	MEADE,G	4.79	7708.76	63	INTERVIEW	X				8.80E-08	9.70E-11	
		MILK ANIMAL												
		MEAT ANIMAL												
		VEGETATION	MEADE,G	4.79	7708.76	63	INTERVIEW	X				8.80E-08	9.70E-11	
		GROUNDWATER	MEADE,G	4.79	7708.76	63	INTERVIEW	X						
E	E	RESIDENCE	LOVE	4.67	7515.64	89	INTERVIEW	X	X			1.10E-07	1.60E-10	
		MILK ANIMAL												
		MEAT ANIMAL	BROTHERS,D	4.91	7901.88	90	INTERVIEW	X				1.00E-07	1.40E-10	
		VEGETATION												
		GROUNDWATER	LOVE	4.67	7515.64	89	INTERVIEW	X	X					
F	ESE	RESIDENCE	WILSON ISLAND	4.22	6791.43	121	INTERVIEW	X	X	X		2.00E-07	2.70E-10	
		MILK ANIMAL												
		MEAT ANIMAL												
		VEGETATION	WILSON ISLAND	4.22	6791.43	121	INTERVIEW	X	X	X		2.00E-07	2.70E-10	
		GROUNDWATER	WILSON ISLAND	4.22	6791.43	121	INTERVIEW	X	X	X				
G	SE	RESIDENCE	CARTER,T	1.67	2687.60	145	CITY REGISTER	X				1.50E-06	4.20E-09	
		MILK ANIMAL												
		MEAT ANIMAL												
		VEGETATION	CARTER, S.	1.99	3202.58	134	CITY REGISTER	X				9.30E-07	2.60E-09	
		GROUNDWATER	HOWELL,J	1.71	2751.98	145	CITY REGISTER	X						

Table 4.0 – 2020 Land Use Survey

FORT CALHOUN STATION
CHEMISTRY FORM

FC-801
REV 1
Page 2 of 3

2020 Environmental Land Use Survey Report

Sector	Dir	Land Use	Owner	Miles	Meters	Deg	Survey Technique	Age Group				XOQ	DOQ	Remarks
								Adult	Teen	Child	Infant			
H	SSE	RESIDENCE	LOMP	.65	1046.07	163	CITY REGISTER	X				6.70E-06	6.00E-08	
		MILK ANIMAL												
		MEAT ANIMAL												
		VEGETATION	PECHNIK,A	.94	1512.78	163	INTERVIEW	X				3.00E-06	2.70E-08	
		GROUNDWATER	LOMP	.65	1046.07	163	CITY REGISTER	X						
J	S	RESIDENCE	DOWLER	.73	1174.82	175	MAIL SURVEY	X				4.20E-06	2.70E-08	
		MILK ANIMAL												
		MEAT ANIMAL	MILLER,M	.66	1062.17	190	MAIL SURVEY	X				5.30E-06	3.40E-08	
		VEGETATION	DOWLER	.73	1174.82	175	MAIL SURVEY	X				4.20E-06	2.70E-08	
		GROUNDWATER	DOWLER	.73	1174.82	175	MAIL SURVEY	X						
K	SSW	RESIDENCE	D.MILLER	.65	1046.07	203	CITY REGISTER	X				4.30E-06	1.40E-08	
		MILK ANIMAL	C. MILLER	3.30	5310.84	210	INTERVIEW	X				9.10E-08	2.30E-10	
		MEAT ANIMAL												
		VEGETATION	ANDERSON,W	.99	1593.25	196	CITY REGISTER	X				1.70E-06	5.70E-09	
		GROUNDWATER	D.MILLER	.65	1046.07	203	CITY REGISTER	X						
L	SW	RESIDENCE	ROBERTSON,D	.73	1174.82	224	MAIL SURVEY	X				3.20E-06	8.50E-09	
		MILK ANIMAL	BARRERA	4.20	6759.24	219	CITY REGISTER	X	X	X		6.40E-08	1.20E-10	
		MEAT ANIMAL	RYDER	.76	1223.10	227	INTERVIEW	X				3.00E-06	7.80E-09	
		VEGETATION	BURGIN	1.43	2301.36	223	CITY REGISTER	X				6.20E-07	1.50E-09	
		GROUNDWATER	ROBERTSON,D	.73	1174.82	224	MAIL SURVEY	X						
M	WSW	RESIDENCE	BENSEN,M	1.06	1705.90	257	CITY REGISTER	X				1.60E-06	4.20E-09	
		MILK ANIMAL												
		MEAT ANIMAL						LIST19						
		VEGETATION	THOMAS	1.13	1818.56	259	CITY REGISTER	X		X		1.30E-06	3.50E-09	
		GROUNDWATER	BENSEN,M	1.06	1705.90	257	CITY REGISTER	X						
N	W	RESIDENCE	NIELSEN	1.20	1931.21	263	CITY REGISTER	X				1.50E-06	4.10E-09	
		MILK ANIMAL												
		MEAT ANIMAL	ANDERSON,J	3.25	5230.37	281	INTERVIEW	X				1.40E-07	3.00E-10	
		VEGETATION												
		GROUNDWATER	KEAS, J.	1.30	2092.15	270	MAIL SURVEY	X		X				
P	WNW	RESIDENCE	LYTLE	2.60	4184.29	283	CITY REGISTER	X				3.40E-07	7.80E-10	
		MILK ANIMAL												
		MEAT ANIMAL	BROWN	4.59	7386.89	288	CITY REGISTER	X				1.30E-07	2.40E-10	
		VEGETATION	TABOR	2.65	4264.76	285	CITY REGISTER	X	X	X		3.20E-07	7.40E-10	
		GROUNDWATER	LYTLE	2.60	4184.29	283	CITY REGISTER	X						

Table 4.0 – 2020 Land Use Survey

FORT CALHOUN STATION
CHEMISTRY FORM

FC-801
REV 1
Page 3 of 3

2020 Environmental Land Use Survey Report

Sector	Dir	Land Use	Owner	Miles	Meters	Deg	Survey Technique	Age Group				XOQ	DOQ	Remarks
								Adult	Teen	Child	Infant			
Q	NW	RESIDENCE	HANSEN,R	2.40	3862.43	318	CITY REGISTER	X				5.20E-07	1.90E-09	
		MILK ANIMAL												
		MEAT ANIMAL												
		VEGETATION	HANSEN,R	2.40	3862.43	318	CITY REGISTER	X				5.20E-07	1.90E-09	
		GROUNDWATER	HANSEN,R	2.40	3862.43	318	CITY REGISTER	X						
R	NNW	RESIDENCE	BATTIATO	2.08	3347.44	330	INTERVIEW	X				8.20E-07	3.40E-09	
		MILK ANIMAL												
		MEAT ANIMAL												
		VEGETATION												
		GROUNDWATER	SONDERUP	3.73	6002.85	328	MAIL SURVEY	X						

Performed by _____ Reviewed by _____

Review of Environmental Inc., Quality Assurance Program

Fort Calhoun Station contracts with Environmental Inc., Midwest Laboratory (vendor lab) to perform radioanalysis of environmental samples. Environmental Inc. participates in inter-laboratory comparison (cross-check) programs as part of its quality control program. These programs are operated by such agencies as the Department of Energy, which supply blind-spike samples such as milk or water containing concentrations of radionuclides unknown to the testing laboratory. This type of program provides an independent check of the analytical laboratory's procedures and processes, and provides indication of possible weaknesses. In addition, Environmental Inc. has its own in-house QA program of blind-spike and duplicate analyses.

Routine FCS REMP duplicate samples were performed by the vendor to verify reproducibility of results. All duplicates were within acceptance criteria.

Environmental resource cross check samples ERDW-53 for Ra-226 failed slightly below the acceptance criteria. The sample was re-run in duplicate and both results were acceptable. ERW-2297 for Ba-133 failed below the lower acceptance limit and no cause for the failure could be identified. NYW-3333 for Uranium failed above the acceptance limit and the uncertainty overlapped the upper acceptance limit. The lab passed the ERA and MAPEP studies for uranium in 2020.

Three DOE MAPEP cross check samples failed in 2020. DOE cross check sample MAAP-664 sample for Gross Alpha failed the acceptance criteria due to the specific calibration caused the bias to shift. The subsequent analysis (MAAP-3101) was acceptable. MAW-599 for Ra-226 and Pu-239/240. The cause of the Ra-226 was inconclusive and the subsequent analyses were acceptable (ERA RAD-121, ERA RAD-122 and NY ELAP shipment 437R). The Pu-239/240 analysis was repeated in duplicate with acceptable results. MAAP-3177 for Cs-134 and Mn-54. The Cs-134 uncertainty overlapped the lower acceptance limit and the Mn-54 was due to a transcription error, which was acceptable when corrected.

No test results failed both the ERA and DOE methodologies for a given sample type. Reanalysis produced acceptable results, so no further action is necessary. The ordering of additional tests and successful testing after corrections were applied, visibly demonstrates the vendor's commitment to reporting and resolving deficiencies.

These results indicate the vendor's ability to self-identify and correct any deviations from acceptable or expected results. The test results had no impact on Fort Calhoun samples and were documented as such by the vendor. No changes are deemed necessary to the FCS REMP program due to vendor performance.



APPENDIX A

INTERLABORATORY AND INTRALABORATORY COMPARISON PROGRAM RESULTS

NOTE: Appendix A is updated four times a year. The complete appendix is included in March, June, September and December monthly progress reports only.

January, 2020 through December, 2020

Appendix A

Interlaboratory/ Intralaboratory Comparison Program Results

Environmental, Inc., Midwest Laboratory has participated in interlaboratory comparison (crosscheck) programs since the formulation of its quality control program in December 1971. These programs are operated by agencies which supply environmental type samples containing concentrations of radionuclides known to the issuing agency but not to participant laboratories. The purpose of such a program is to provide an independent check on a laboratory's analytical procedures and to alert it of any possible problems.

Participant laboratories measure the concentration of specified radionuclides and report them to the issuing agency. Several months later, the agency reports the known values to the participant laboratories and specifies control limits. Results consistently higher or lower than the known values or outside the control limits indicate a need to check the instruments or procedures used.

Results in Table A-1 were obtained through participation in the RAD PT Study Proficiency Testing Program administered by Environmental Resource Associates, serving as a replacement for studies conducted previously by the U.S. EPA Environmental Monitoring Systems Laboratory, Las Vegas, Nevada.

Results in Table A-2 were obtained through participation in the New York Department of Health Environmental Laboratory Approval Program (ELAP) PT.

Table A-3 lists results for thermoluminescent dosimeters (TLDs), via irradiation and evaluation by the University of Wisconsin-Madison Radiation Calibration Laboratory at the University of Wisconsin Medical Radiation Research Center.

Table A-4 lists results of the analyses on intralaboratory "spiked" samples for the past twelve months. All samples are prepared using NIST traceable sources. Data for previous years available upon request.

Table A-5 lists results of the analyses on intralaboratory "blank" samples for the past twelve months. Data for previous years available upon request.

Table A-6 lists analytical results from the intralaboratory "duplicate" program for the past twelve months. Acceptance is based on each result being within 25% of the mean of the two results or the two sigma uncertainties of each result overlap.

The results in Table A-7 were obtained through participation in the Mixed Analyte Performance Evaluation Program.

Results in Table A-8 were obtained through participation in the MRAD PT Study Proficiency Testing Program administered by Environmental Resource Associates, serving as a replacement for studies conducted previously by the Environmental Measurement Laboratory Quality Assessment Program (EML).

Attachment A lists the laboratory acceptance criteria for various analyses.

Out-of-limit results are explained directly below the result.

Attachment A

ACCEPTANCE CRITERIA FOR INTRALABORATORY "SPIKED" SAMPLES

<u>Analysis</u>	<u>Ratio of lab result to known value.</u>
Gamma Emitters	0.8 to 1.2
Strontium-89, Strontium-90	0.8 to 1.2
Potassium-40	0.8 to 1.2
Gross alpha	0.5 to 1.5
Gross beta	0.8 to 1.2
Tritium	0.8 to 1.2
Radium-226, Radium-228	0.7 to 1.3
Plutonium	0.8 to 1.2
Iodine-129, Iodine-131	0.8 to 1.2
Nickel-63, Technetium-99, Uranium-238	0.7 to 1.3
Iron-55	0.8 to 1.2
Other Analyses	0.8 to 1.2

TABLE A-1. Interlaboratory Comparison Crosscheck program, Environmental Resource Associates (ERA)^a.
RAD study

Lab Code	Date	Analysis	Concentration (pCi/L)			Acceptance
			Laboratory Result	ERA Result	Control Limits	
RAD-120 Study						
ERW-49	1/6/2020	Ba-133	60.8 ± 4.4	64.5	53.7 - 71.0	Pass
ERW-49	1/6/2020	Cs-134	22.7 ± 2.8	22.9	17.5 - 25.6	Pass
ERW-49	1/6/2020	Cs-137	225 ± 8	220	198 - 244	Pass
ERW-49	1/6/2020	Co-60	94.6 ± 4.6	91.2	82.1 - 103	Pass
ERW-49	1/6/2020	Zn-65	331 ± 13	298	268 - 348	Pass
ERDW-51	1/6/2020	Gr. Alpha	52.3 ± 2.4	58.9	30.8 - 73.3	Pass
ERDW-51	1/6/2020	Gr. Beta	19.9 ± 1.0	21.0	12.6 - 29.1	Pass
ERDW-53	1/6/2020	Ra-226	12.8 ± 0.5	17.4	12.9 - 19.9	Fail ^b
ERDW-53	1/6/2020	Ra-228	7.13 ± 0.9	7.95	5.06 - 10.1	Pass
ERDW-53	1/6/2020	Uranium	63.8 ± 1.0	68.2	55.7 - 75.0	Pass
ERW-55	1/6/2020	H-3	18,200 ± 408	17,800	15,600 - 19,600	Pass
RAD-121 Study						
ERDW-1034	4/6/2020	Ra-226	17.8 ± 0.5	18.4	13.7 - 21.0	Pass
ERDW-1034	4/6/2020	Ra-228	6.30 ± 0.86	5.81	3.56 - 7.64	Pass
ERDW-1034	4/6/2020	Uranium	18.7 ± 1.3	18.6	14.9 - 20.9	Pass
RAD-122 Study						
ERW-2297	7/6/2020	Ba-133	43.8 ± 3.4	58.6	48.6 - 64.6	Fail ^c
ERW-2297	7/6/2020	Cs-134	19.8 ± 2.4	22.3	17.0 - 25.0	Pass
ERW-2297	7/6/2020	Cs-137	73.2 ± 5.4	73.0	65.7 - 83.0	Pass
ERW-2297	7/6/2020	Co-60	90.0 ± 4.0	86.1	77.5 - 97.0	Pass
ERW-2297	7/6/2020	Zn-65	84.9 ± 7.5	82.9	74.6 - 99.6	Pass
ERDW-2299	7/6/2020	Gr. Alpha	40.3 ± 2.2	52.40	27.30 - 65.6	Pass
ERDW-2299	7/6/2020	Gr. Beta	19.9 ± 1.0	24.3	15.0 - 32.3	Pass
ERDW-2303	7/6/2020	Ra-226	8.91 ± 0.43	10.8	8.08 - 12.5	Pass
ERDW-2303	7/6/2020	Ra-228	4.79 ± 0.80	5.42	3.28 - 7.19	Pass
ERDW-2303	7/6/2020	Uranium	27.7 ± 0.9	29.3	23.7 - 32.5	Pass
ERW-2305	7/6/2020	H-3	21,100 ± 400	20,300	17,800 - 22,300	Pass
ERW-2301	7/6/2020	I-131	27.8 ± 1.2	26.1	21.7 - 30.8	Pass

^a Results obtained by Environmental, Inc., Midwest Laboratory as a participant in the crosscheck program for proficiency testing in drinking water conducted by Environmental Resource Associates (ERA).

^b Ra-226 was slightly below the lower limit of the study. The reported value was the mean of two results (12.5 & 13.0). The sample was re-run in duplicate and both results, 15.6 and 13.8 pCi/L, were within the acceptance band.

^c Ba-133 was below the lower acceptable limit of the study. No cause for the failure could be identified. Going forward gamma results will be monitored to see if any trend develops.

TABLE A-2. Interlaboratory Comparison Crosscheck program, New York Department of Health (ELAP)^a.

Lab Code	Date	Concentration (pCi/L)				Acceptance Limits	Acceptance
		Analysis	Laboratory Result	Assigned Value			
Shipment 437R							
NYW-3307	9/15/2020	H-3	11,500 ± 465	11,208	9760 - 12,300	Pass	
NYW-3331	9/15/2020	Gross Alpha	43.7 ± 2.5	64.9	34.0 - 80.4	Pass	
NYW-3331	9/15/2020	Gross Beta	11.1 ± 1.1	8.85	3.62 - 17.4	Pass	
NYW-3335	9/15/2020	I-131	14.1 ± 1.4	12.6	10.3 - 16.0	Pass	
NYW-3333	9/15/2020	Ra-226	2.24 ± 0.27	2.63	2.06 - 3.44	Pass	
NYW-3333	9/15/2020	Ra-228	4.91 ± 1.12	5.41	3.27 - 7.18	Pass	
NYW-3333	9/15/2020	Uranium	42.8 ± 1.94	37.1	30.1 - 41.0	Fail ^b	
NYW-3337	9/15/2020	Co-60	46.4 ± 3.8	42.3	38.1 - 49.2	Pass	
NYW-3337	9/15/2020	Zn-65	133 ± 9	116	104 - 138	Pass	
NYW-3337	9/15/2020	Ba-133	49.5 ± 4.1	46.4	38.0 - 51.6	Pass	
NYW-3337	9/15/2020	Cs-134	32.5 ± 3.1	33.0	26.0 - 36.3	Pass	
NYW-3337	9/15/2020	Cs-137	147 ± 7	134	121 - 150	Pass	

^a Results obtained by Environmental, Inc., Midwest Laboratory as a participant in the crosscheck program for proficiency testing in drinking water conducted by the New York Department of Health Laboratory Approval Program (NY ELAP).

^b Lab passed all ERA and MAPEP studies for uranium in 2020. (See tables A-1, A-7 and A-8) Uncertainty overlapped upper acceptance limit. Lab will continue to monitor results going forward for trends.

TABLE A-3. Thermoluminescent Dosimetry, (TLD, CaSO₄: Dy Cards).^a

Lab Code	Irradiation Date	Description	mrem		Performance ^c Quotient (P)	
			Delivered Dose	Reported ^b Dose		
<u>Environmental, Inc.</u>		Group 1				
2020-1	10/28/2020	Spike 1	172.0	180.0	0.05	
2020-1	10/28/2020	Spike 2	172.0	174.5	0.01	
2020-1	10/28/2020	Spike 3	172.0	174.3	0.01	
2020-1	10/28/2020	Spike 4	172.0	174.0	0.01	
2020-1	10/28/2020	Spike 5	172.0	167.1	-0.03	
2020-1	10/28/2020	Spike 6	172.0	161.9	-0.06	
2020-1	10/28/2020	Spike 7	172.0	167.9	-0.02	
2020-1	10/28/2020	Spike 8	172.0	171.0	-0.01	
2020-1	10/28/2020	Spike 9	172.0	170.7	-0.01	
2020-1	10/28/2020	Spike 10	172.0	170.1	-0.01	
2020-1	10/28/2020	Spike 11	172.0	173.8	0.01	
2020-1	10/28/2020	Spike 12	172.0	178.3	0.04	
2020-1	10/28/2020	Spike 13	172.0	178.2	0.04	
2020-1	10/28/2020	Spike 14	172.0	171.9	0.00	
2020-1	10/28/2020	Spike 15	172.0	190.4	0.11	
2020-1	10/28/2020	Spike 16	172.0	170.9	-0.01	
2020-1	10/28/2020	Spike 17	172.0	183.3	0.07	
2020-1	10/28/2020	Spike 18	172.0	170.6	-0.01	
2020-1	10/28/2020	Spike 19	172.0	164.9	-0.04	
2020-1	10/28/2020	Spike 20	172.0	175.7	0.02	
Mean (Spike 1-20)				173.5	0.01	Pass ^d
Standard Deviation (Spike 1-20)				6.5	0.04	Pass ^d

a TLD's were irradiated by the University of Wisconsin-Madison Radiation Calibration Laboratory following ANSI N13.37 protocol from a known air kerma rate. TLD's were read and the results were submitted by Environmental Inc. to the University of Wisconsin-Madison Radiation Calibration Laboratory for comparison to the delivered dose.

b Reported dose was converted from exposure (R) to Air Kerma (cGy) using a conversion of 0.876. Conversion from air kerma to ambient dose equivalent for Cs-137 at the reference dose point $H^*(10)K_a = 1.20$. $mrem/cGy = 1000$.

c Performance Quotient (P) is calculated as $((\text{reported dose} - \text{conventionally true value}) \div \text{conventionally true value})$ where the conventionally true value is the delivered dose.

d Acceptance is achieved when neither the absolute value of the mean of the P values, nor the standard deviation of the P values exceed 0.15.

TABLE A-3. Thermoluminescent Dosimetry, (TLD, CaSO₄: Dy Cards).^a

Lab Code	Irradiation Date	Description	mrem		Performance ^c Quotient (P)	
			Delivered Dose	Reported ^b Dose		
<u>Environmental, Inc.</u>		Group 2				
2020-2	10/28/2020	Spike 21	114.0	117.3	0.03	
2020-2	10/28/2020	Spike 22	114.0	103.3	-0.09	
2020-2	10/28/2020	Spike 23	114.0	106.2	-0.07	
2020-2	10/28/2020	Spike 24	114.0	110.1	-0.03	
2020-2	10/28/2020	Spike 25	114.0	114.9	0.01	
2020-2	10/28/2020	Spike 26	114.0	115.5	0.01	
2020-2	10/28/2020	Spike 27	114.0	110.4	-0.03	
2020-2	10/28/2020	Spike 28	114.0	111.7	-0.02	
2020-2	10/28/2020	Spike 29	114.0	111.3	-0.02	
2020-2	10/28/2020	Spike 30	114.0	113.1	-0.01	
2020-2	10/28/2020	Spike 31	114.0	116.4	0.02	
2020-2	10/28/2020	Spike 32	114.0	111.8	-0.02	
2020-2	10/28/2020	Spike 33	114.0	112.6	-0.01	
2020-2	10/28/2020	Spike 34	114.0	105.7	-0.07	
2020-2	10/28/2020	Spike 35	114.0	104.5	-0.08	
2020-2	10/28/2020	Spike 36	114.0	103.6	-0.09	
2020-2	10/28/2020	Spike 37	114.0	104.4	-0.08	
2020-2	10/28/2020	Spike 38	114.0	104.5	-0.08	
2020-2	10/28/2020	Spike 39	114.0	106.4	-0.07	
2020-2	10/28/2020	Spike 40	114.0	107.7	-0.06	
Mean (Spike 21-40)				109.6	-0.04	Pass ^d
Standard Deviation (Spike 21-40)				4.6	0.04	Pass ^d

a TLD's were irradiated by the University of Wisconsin-Madison Radiation Calibration Laboratory following ANSI N13.37 protocol from a known air kerma rate. TLD's were read and the results were submitted by Environmental Inc. to the University of Wisconsin-Madison Radiation Calibration Laboratory for comparison to the delivered dose.

b Reported dose was converted from exposure (R) to Air Kerma (cGy) using a conversion of 0.876. Conversion from air kerma to ambient dose equivalent for Cs-137 at the reference dose point $H^*(10)K_a = 1.20$. mrem/cGy = 1000.

c Performance Quotient (P) is calculated as ((reported dose - conventionally true value) ÷ conventionally true value) where the conventionally true value is the delivered dose.

d Acceptance is achieved when neither the absolute value of the mean of the P values, nor the standard deviation of the P values exceed 0.15.

TABLE A-4. Intralaboratory "Spiked" Samples

Lab Code ^b	Date	Analysis	Concentration ^a			Acceptance	Ratio Lab/Known
			Laboratory results 2s, n=1 ^c	Known Activity	Control Limits ^d		
SPW-481	1/1/2020	Ra-226	10.4 ± 0.3	12.3	8.6 - 16.0	Pass	0.85
SPW-110	1/16/2020	H-3	2,101 ± 154	2,110	1,688 - 2,532	Pass	1.00
W-041620	4/29/2016	Cs-134	35.7 ± 8.8	36.2	29.0 - 43.4	Pass	0.99
W-041620	4/29/2016	Cs-137	75.0 ± 6.6	71.9	57.5 - 86.3	Pass	1.04
W-042020	4/29/2016	Cs-134	40.6 ± 10.2	36.2	29.0 - 43.4	Pass	1.12
W-042020	4/29/2016	Cs-137	71.2 ± 7.0	71.9	57.5 - 86.3	Pass	0.99
SPW-190	1/23/2020	H-3	2,058 ± 153	2,110	1,688 - 2,532	Pass	0.98
SPW-205	1/28/2020	Sr-90	17.6 ± 1.2	17.9	14.3 - 21.5	Pass	0.99
SPW-217	1/31/2020	H-3	2,005 ± 152	2,110	1,688 - 2,532	Pass	0.95
SPW-270	2/7/2020	H-3	2,153 ± 157	2,110	1,688 - 2,532	Pass	1.02
SPW-288	2/11/2020	Ra-228	13.1 ± 1.7	14.9	10.4 - 19.3	Pass	0.88
W-021220	4/29/2016	Cs-134	39.3 ± 18.9	36.2	29.0 - 43.4	Pass	1.09
W-021220	4/29/2016	Cs-137	73.9 ± 15.8	71.9	57.5 - 86.3	Pass	1.03
SPW-396	2/14/2020	H-3	2,298 ± 160	2,110	1,688 - 2,532	Pass	1.09
W-022420	4/29/2016	Cs-134	33.4 ± 10.5	36.2	29.0 - 43.4	Pass	0.92
W-022420	4/29/2016	Cs-137	75.6 ± 7.8	71.9	57.5 - 86.3	Pass	1.05
SPW-716	2/26/2020	Ra-226	11.3 ± 0.4	12.3	8.6 - 16.0	Pass	0.92
W-022820	4/29/2016	Cs-134	34.9 ± 11.6	36.2	29.0 - 43.4	Pass	0.96
W-022820	4/29/2016	Cs-137	82.9 ± 8.5	71.9	57.5 - 86.3	Pass	1.15
SPW-532	2/28/2020	H-3	2,054 ± 153	2,110	1,688 - 2,532	Pass	0.97
W-030420	4/29/2016	Cs-134	29.7 ± 9.6	36.2	29.0 - 43.4	Pass	0.82
W-030420	4/29/2016	Cs-137	74.2 ± 7.3	71.9	57.5 - 86.3	Pass	1.03
W-031020	4/29/2016	Cs-134	41.6 ± 17.8	36.2	29.0 - 43.4	Pass	1.15
W-031020	4/29/2016	Cs-137	78.6 ± 14.3	71.9	57.5 - 86.3	Pass	1.09
SPW-711	3/12/2020	H-3	2,083 ± 154	2,110	1,688 - 2,532	Pass	0.99
SPW-825	3/12/2020	Ra-226	12.4 ± 0.4	12.3	8.6 - 16.0	Pass	1.01
SPW-774	3/18/2020	H-3	2,021 ± 151	2,110	1,688 - 2,532	Pass	0.96
W-031820	4/29/2016	Cs-134	29.7 ± 10.6	36.2	29.0 - 43.4	Pass	0.82
W-031820	4/29/2016	Cs-137	75.5 ± 9.2	71.9	57.5 - 86.3	Pass	1.05
W-032520	4/29/2016	Cs-134	36.4 ± 9.2	36.2	29.0 - 43.4	Pass	1.01
W-032520	4/29/2016	Cs-137	74.9 ± 7.0	71.9	57.5 - 86.3	Pass	1.04
SPW-877	3/31/2020	Ra-228	13.0 ± 2.0	14.9	10.4 - 19.3	Pass	0.88
SPW-925	3/23/2020	Ra-226	10.7 ± 0.4	12.3	8.6 - 16.0	Pass	0.87
SPW-859	3/27/2020	H-3	2,065 ± 153	2,110	1,688 - 2,532	Pass	0.98
W-040320	4/29/2016	Cs-134	38.1 ± 10.3	36.2	29.0 - 43.4	Pass	1.05
W-040320	4/29/2016	Cs-137	78.6 ± 7.5	71.9	57.5 - 86.3	Pass	1.09
SPDW-1009	4/8/2020	Gr. Alpha	11.5 ± 0.9	18.7	9.4 - 28.1	Pass	0.61
SPDW-1009	4/8/2020	Gr. Beta	22.0 ± 1.0	26.1	20.9 - 31.3	Pass	0.84
SPW-1033	4/9/2020	H-3	2,041 ± 153	2,110	1,688 - 2,532	Pass	0.97
W-040920	4/29/2016	Cs-134	34.3 ± 9.4	36.2	29.0 - 43.4	Pass	0.95
W-040920	4/29/2016	Cs-137	77.9 ± 8.0	71.9	57.5 - 86.3	Pass	1.08
SPW-1145	4/15/2020	Ra-228	14.3 ± 2.0	14.9	10.4 - 19.3	Pass	0.96
SPW-1186	4/17/2020	H-3	1,972 ± 151	2,110	1,688 - 2,532	Pass	0.93

^a Liquid sample results are reported in pCi/Liter, air filters (pCi/m3), charcoal (pCi/charcoal canister), and solid samples (pCi/kg).

^b Laboratory codes : W & SPW (Water), MI (milk), AP (air filter), SO (soil), VE (vegetation), CH (charcoal canister), F (fish), U (urine).

^c Results are based on single determinations.

^d Acceptance criteria are listed in Attachment A of this report.

TABLE A-4. Intralaboratory "Spiked" Samples

Lab Code ^b	Date	Analysis	Concentration ^a			Acceptance	Ratio Lab/Known
			Laboratory results 2s, n=1 ^c	Known Activity	Control Limits ^d		
SPW-1284	4/24/2020	H-3	2,015 ± 153	2,110	1,688 - 2,532	Pass	0.95
SPW-1745	4/24/2020	Ra-226	11.9 ± 0.3	12.3	8.6 - 16.0	Pass	0.97
W-042220	4/29/2016	Cs-134	33.7 ± 9.2	36.2	29.0 - 43.4	Pass	0.93
W-042220	4/29/2016	Cs-137	74.9 ± 6.6	71.9	57.5 - 86.3	Pass	1.04
W-042420	4/29/2016	Cs-134	33.3 ± 10.8	36.2	29.0 - 43.4	Pass	0.92
W-042420	4/29/2016	Cs-137	73.7 ± 8.5	71.9	57.5 - 86.3	Pass	1.03
W-043020	4/29/2016	Cs-134	33.7 ± 15.7	36.2	29.0 - 43.4	Pass	0.93
W-043020	4/29/2016	Cs-137	72.5 ± 7.1	71.9	57.5 - 86.3	Pass	1.01
SPW-1327	5/1/2020	H-3	2,071 ± 153	2,110	1,688 - 2,532	Pass	0.98
W-050520	4/29/2016	Cs-134	31.1 ± 11.9	36.2	29.0 - 43.4	Pass	0.86
W-050520	4/29/2016	Cs-137	73.2 ± 8.3	71.9	57.5 - 86.3	Pass	1.02
SPW-1394	5/5/2020	Sr-90	18.1 ± 1.1	17.9	14.3 - 21.5	Pass	1.01
W-050720	4/29/2016	Cs-134	39.9 ± 2.0	36.2	29.0 - 43.4	Pass	1.10
W-050720	4/29/2016	Cs-137	75.2 ± 14.3	71.9	57.5 - 86.3	Pass	1.05
SPW-1500	5/18/2020	Ra-228	13.8 ± 1.9	14.9	10.4 - 19.3	Pass	0.93
W-052020	4/29/2016	Cs-134	33.1 ± 1.2	36.2	29.0 - 43.4	Pass	0.91
W-052020	4/29/2016	Cs-137	80.8 ± 8.3	71.9	57.5 - 86.3	Pass	1.12
SPW-1613	5/22/2020	H-3	1,953 ± 149	2,110	1,688 - 2,532	Pass	0.93
W-052620	4/29/2016	Cs-134	31.0 ± 9.2	36.2	29.0 - 43.4	Pass	0.86
W-052620	4/29/2016	Cs-137	74.6 ± 7.5	71.9	57.5 - 86.3	Pass	1.04
SPW-2061	5/21/2020	Ra-226	10.4 ± 0.3	12.3	8.6 - 16.0	Pass	0.85
W-052620	4/29/2016	Cs-134	33.6 ± 12.8	36.2	29.0 - 43.4	Pass	0.93
W-052620	4/29/2016	Cs-137	69.2 ± 7.7	71.9	57.5 - 86.3	Pass	0.96
SPW-1741	5/27/2020	H-3	1,925 ± 150	2,110	1,688 - 2,532	Pass	0.91
SPW-1824	6/3/2020	H-3	1,971 ± 151	2,110	1,688 - 2,532	Pass	0.93
SPW-1853	6/4/2020	H-3	2,027 ± 153	2,110	1,688 - 2,532	Pass	0.96
W-061120	4/29/2016	Cs-134	39.8 ± 21.0	36.2	29.0 - 43.4	Pass	1.10
W-061120	4/29/2016	Cs-137	79.3 ± 13.5	71.9	57.5 - 86.3	Pass	1.10
SPW-1982	6/12/2020	H-3	2,065 ± 154	2,110	1,688 - 2,532	Pass	0.98
SPW-2038	6/18/2020	H-3	2,012 ± 154	2,110	1,688 - 2,532	Pass	0.95
SPW-2116	6/25/2020	H-3	2,051 ± 159	2,110	1,688 - 2,532	Pass	0.97
SPW-2173	7/1/2020	H-3	2,010 ± 154	2,110	1,688 - 2,532	Pass	0.95
SPW-2328	7/10/2020	H-3	1,924 ± 151	2,110	1,688 - 2,532	Pass	0.91
SPW-2458	7/16/2020	H-3	1,932 ± 151	2,110	1,688 - 2,532	Pass	0.92
SPW-2556	7/27/2020	Sr-90	16.8 ± 1.1	17.9	14.3 - 21.5	Pass	0.94
SPW-2558	7/6/2020	Gr. Alpha	29.9 ± 2.1	58.9	29.5 - 88.4	Pass	0.51
SPW-2558	7/6/2020	Gr. Beta	20.0 ± 1.0	21.0	16.8 - 25.2	Pass	0.95
SPW-2640	7/31/2020	H-3	1,984 ± 154	2,110	1,688 - 2,532	Pass	0.94
SPW-2778	8/7/2020	H-3	1,936 ± 151	2,110	1,688 - 2,532	Pass	0.92
SPW-2797	6/22/2020	Ra-226	10.4 ± 0.3	12.3	8.6 - 16.0	Pass	0.85
SPW-2852	8/11/2020	Ra-228	10.2 ± 1.6	12.5	8.7 - 16.2	Pass	0.82

^a Liquid sample results are reported in pCi/Liter, air filters (pCi/m3), charcoal (pCi/charcoal canister), and solid samples (pCi/kg).

^b Laboratory codes : W & SPW (Water), MI (milk), AP (air filter), SO (soil), VE (vegetation), CH (charcoal canister), F (fish), U (urine).

^c Results are based on single determinations.

^d Acceptance criteria are listed in Attachment A of this report.

TABLE A-4. Intralaboratory "Spiked" Samples

Lab Code ^b	Date	Analysis	Concentration ^a				Acceptance	Ratio Lab/Known
			Laboratory results 2s, n=1 ^c	Known Activity	Control Limits ^d			
SPW-2854	8/14/2020	H-3	1,927 ± 153	2,110	1,688 - 2,532	Pass	0.91	
SPW-2890	8/4/2020	Ra-226	11.6 ± 0.4	12.3	8.6 - 16.0	Pass	0.95	
SPW-3013	8/24/2020	H-3	2,005 ± 153	2,110	1,688 - 2,532	Pass	0.95	
SPW-3053	8/28/2020	H-3	1,904 ± 149	2,110	1,688 - 2,532	Pass	0.90	
SPW-3123	8/19/2020	Ra-226	10.4 ± 0.3	12.3	8.6 - 16.0	Pass	0.85	
SPW-3447	9/3/2020	Ra-226	9.8 ± 0.3	12.3	8.6 - 16.0	Pass	0.80	
SPW-3241	9/11/2020	H-3	1,952 ± 154	2,110	1,688 - 2,532	Pass	0.93	
SPW-3425	9/23/2020	Ra-228	10.7 ± 1.6	12.3	8.6 - 16.0	Pass	0.87	
SPW-3412	9/25/2020	H-3	2,099 ± 155	2,110	1,688 - 2,532	Pass	0.99	
SPW-4131	9/30/2020	Ra-226	13.2 ± 0.4	12.3	8.6 - 16.0	Pass	1.07	
SPW-3482	10/2/2020	H-3	1,984 ± 154	2,110	1,688 - 2,532	Pass	0.94	
SPW-3624	10/9/2020	H-3	1,924 ± 152	2,110	1,688 - 2,532	Pass	0.91	
SPW-3794	10/16/2020	H-3	2,109 ± 156	2,110	1,688 - 2,532	Pass	1.00	
SPW-3836	10/20/2020	Sr-90	16.8 ± 1.1	17.9	14.3 - 21.5	Pass	0.94	
SPW-4043	10/23/2020	H-3	1893.4 ± 148.8	2,110	1,688 - 2,532	Pass	0.90	
SPW-4179	10/28/2020	Ra-228	15.4 ± 2.4	12.1	8.5 - 15.7	Pass	1.27	
SPW-4422	10/30/2020	Ra-226	12.3 ± 0.3	12.3	8.6 - 16.0	Pass	1.00	
SPW-4234	11/11/2020	H-3	2,008 ± 154	2,110	1,688 - 2,532	Pass	0.95	
SPW-4634	11/23/2020	Ra-226	11.4 ± 0.3	12.3	8.6 - 16.0	Pass	0.93	
SPW-4509	12/4/2020	H-3	1,873 ± 149	2,110	1,688 - 2,532	Pass	0.89	
SPW-4625	12/18/2020	H-3	1,940 ± 152	2,110	1,688 - 2,532	Pass	0.92	
SPW-4741	12/18/2020	Ra-226	12.5 ± 0.4	12.3	8.6 - 16.0	Pass	1.02	

^a Liquid sample results are reported in pCi/Liter, air filters (pCi/m3), charcoal (pCi/charcoal canister), and solid samples (pCi/kg).

^b Laboratory codes : W & SPW (Water), MI (milk), AP (air filter), SO (soil), VE (vegetation), CH (charcoal canister), F (fish), U (urine).

^c Results are based on single determinations.

^d Acceptance criteria are listed in Attachment A of this report.

TABLE A-5. Intralaboratory "Blank" Samples

Lab Code ^b	Sample Type	Date	Analysis ^c	Concentration ^a		Acceptance Criteria (4.66 σ)
				Laboratory results (4.66 σ)		
				LLD	Activity ^d	
SPW-480	Water	1/1/2020	Ra-226	0.03	0.12 ± 0.02	2
SPW-93	Water	1/7/2020	Gr. Alpha	0.35	0.47 ± 0.29	2
SPW-93	Water	1/7/2020	Gr. Beta	0.74	0.18 ± 0.53	4
SPW-109	Water	1/16/2020	H-3	157	-6 ± 73	200
SPW-154	Water	1/16/2020	I-131	0.47	-0.22 ± 0.21	1
SPW-189	Water	1/23/2020	H-3	158	0 ± 73	200
SPW-204	Water	1/28/2020	Sr-89	0.64	-0.16 ± 0.50	5
SPW-204	Water	1/28/2020	Sr-90	0.54	0.11 ± 0.27	1
SPW-216	Water	1/31/2020	H-3	156	86 ± 78	200
SPW-269	Water	2/7/2020	H-3	153	79 ± 80	200
SPW-287	Water	2/11/2020	Ra-228	0.81	1.49 ± 0.53	2
SPW-395	Water	2/14/2020	H-3	154	46 ± 75	200
SPW-463	Water	2/25/2020	I-131	0.16	0.02 ± 0.09	1
SPW-715	Water	2/26/2020	Ra-226	0.01	0.17 ± 0.01	2
SPW-531	Water	2/28/2020	H-3	156	44 ± 75	200
SPW-710	Water	3/12/2020	H-3	157	-16 ± 72	200
SPW-824	Water	3/12/2020	Ra-226	0.03	0.15 ± 0.03	2
SPW-773	Water	3/18/2020	H-3	151	76 ± 76	200
SPW-876	Water	3/31/2020	Ra-228	0.88	0.57 ± 0.47	2
SPW-924	Water	3/23/2020	Ra-226	0.04	0.18 ± 0.03	2
SPW-1032	Water	4/9/2020	H-3	157	68 ± 77	200
SPW-1144	Water	4/15/2020	Ra-228	0.89	0.03 ± 0.42	2
SPW-1185	Water	4/17/2020	H-3	158	8 ± 74	200
SPW-1283	Water	4/24/2020	H-3	156	10 ± 75	200
SPW-1744	Water	4/24/2020	Ra-226	0.03	-0.01 ± 0.03	2
SPW-1326	Water	5/1/2020	H-3	153	67 ± 75	200
SPW-1393	Water	5/5/2020	Sr-89	0.66	0.11 ± 0.44	5
SPW-1393	Water	5/5/2020	Sr-90	0.63	-0.27 ± 0.26	1
SPW-1499	Water	5/18/2020	Ra-228	0.88	0.03 ± 0.41	2
SPW-1541	Water	5/19/2020	I-131	0.20	0.00 ± 0.11	1
SPW-2060	Water	5/21/2020	Ra-226	0.03	-0.01 ± 0.02	2
SPW-1612	Water	5/22/2020	H-3	153	91 ± 76	200
SPW-1740	Water	5/27/2020	H-3	158	-26 ± 71	200
SPW-1823	Water	6/3/2020	H-3	157	18 ± 74	200
SPW-1852	Water	6/4/2020	H-3	159	33 ± 76	200
SPW-1981	Water	6/12/2020	H-3	149	52 ± 77	200
SPW-2037	Water	6/18/2020	H-3	156	101 ± 81	200
SPW-2115	Water	6/25/2020	H-3	158	56 ± 86	200

^a Liquid sample results are reported in pCi/Liter, air filters (pCi/m³), charcoal (pCi/charcoal canister), and solid samples (pCi/g).

^b Laboratory codes : W & SPW (Water), MI (milk), AP (air filter), SO (soil), VE (vegetation), CH (charcoal canister), F (fish), U (urine).

^c I-131(G); iodine-131 as analyzed by gamma spectroscopy.

^d Activity reported is a net activity result.

TABLE A-5. Intralaboratory "Blank" Samples

Lab Code ^b	Sample Type	Date	Analysis ^c	Concentration ^a		
				Laboratory results (4.66 σ)		Acceptance Criteria (4.66 σ)
				LLD	Activity ^d	
SPW-2172	Water	7/1/2020	H-3	159	-15 \pm 75	200
SPW-2327	Water	7/10/2020	H-3	158	50 \pm 77	200
SPW-2457	Water	7/16/2020	H-3	159	-46 \pm 71	200
SPW-2555	Water	7/27/2020	Sr-89	0.48	0.18 \pm 0.40	5
SPW-2555	Water	7/27/2020	Sr-90	0.54	0.03 \pm 0.25	1
SPW-2557	Water	7/6/2020	Gr. Alpha	0.37	0.25 \pm 0.28	2
SPW-2557	Water	7/6/2020	Gr. Beta	0.75	-0.23 \pm 0.52	4
SPW-2639	Water	7/31/2020	H-3	158	80 \pm 81	200
SPW-2777	Water	8/7/2020	H-3	157	0 \pm 74	200
SPW-2796	Water	6/22/2020	Ra-226	0.03	-0.02 \pm 0.03	2
SPW-2851	Water	8/11/2020	Ra-228	0.85	0.44 \pm 0.45	2
SPW-2853	Water	8/14/2020	H-3	158	18 \pm 77	200
SPW-2880	Water	8/18/2020	I-131	0.42	-0.04 \pm 0.22	1
SPW-2889	Water	8/4/2020	Ra-228	0.05	0.13 \pm 0.11	2
SPW-3012	Water	8/24/2020	H-3	159	59 \pm 77	200
SPW-3052	Water	8/28/2020	H-3	155	46 \pm 75	200
SPW-3122	Water	9/3/2020	Ra-226	0.03	0.20 \pm 0.03	2
SPW-3240	Water	9/11/2020	H-3	161	3 \pm 78	200
SPW-3446	Water	9/3/2020	Ra-226	0.01	0.12 \pm 0.02	2
SPW-3424	Water	9/23/2020	Ra-228	0.85	0.81 \pm 0.48	2
SPW-3411	Water	9/25/2020	H-3	158	82 \pm 78	200
SPW-4130	Water	9/30/2020	Ra-226	0.04	0.01 \pm 0.04	2
SPW-3481	Water	10/2/2020	H-3	154	63 \pm 80	200
SPW-3623	Water	10/9/2020	H-3	156	57 \pm 81	200
SPW-3793	Water	10/16/2020	H-3	157	3 \pm 73	200
SPW-3835	Water	10/20/2020	Sr-89	0.55	-0.10 \pm 0.43	5
SPW-3835	Water	10/20/2020	Sr-90	0.59	0.09 \pm 0.28	1
SPW-4042	Water	10/23/2020	H-3	155	-6 \pm 72	200
SPW-4178	Water	10/28/2020	Ra-228	1.04	0.33 \pm 0.52	2
SPW-4421	Water	10/30/2020	Ra-226	0.03	0.07 \pm 0.03	2
SPW-4233	Water	11/11/2020	H-3	155	78 \pm 79	200
SPW-4356	Water	11/20/2020	H-3	157	52 \pm 76	200
SPW-4633	Water	11/23/2020	Ra-226	0.05	0.04 \pm 0.11	2
SPW-4508	Water	12/4/2020	H-3	159	-68 \pm 69	200
SPW-4624	Water	12/18/2020	H-3	160	8 \pm 77	200
SPW-4740	Water	12/18/2020	Ra-226	0.04	0.02 \pm 0.03	2

^a Liquid sample results are reported in pCi/Liter, air filters (pCi/m³), charcoal (pCi/charcoal canister), and solid samples (pCi/g).

^b Laboratory codes : W & SPW (Water), MI (milk), AP (air filter), SO (soil), VE (vegetation), CH (charcoal canister), F (fish), U (urine).

^c I-131(G); iodine-131 as analyzed by gamma spectroscopy.

^d Activity reported is a net activity result.

TABLE A-6. Intralaboratory "Duplicate" Samples

Lab Code ^b	Date	Analysis	Concentration ^a		Averaged Result	Acceptance
			First Result	Second Result		
SG-20,21	1/2/2020	Pb-214	2.23 ± 0.12	1.61 ± 0.09	1.92 ± 0.08	Pass
SG-20,21	1/2/2020	Ac-228	1.49 ± 0.20	1.42 ± 0.18	1.46 ± 0.13	Pass
AP-5060,5061	1/3/2020	Be-7	0.052 ± 0.014	0.063 ± 0.012	0.057 ± 0.009	Pass
AP-010720A,B	1/7/2020	Gr. Beta	0.023 ± 0.004	0.022 ± 0.004	0.022 ± 0.003	Pass
WW-72,73	1/7/2020	H-3	547 ± 101	478 ± 98	513 ± 70	Pass
WW-184,185	1/21/2020	H-3	265 ± 88	311 ± 90	288 ± 63	Pass
SWU-253,254	1/28/2020	Gr. Beta	1.73 ± 0.58	2.10 ± 0.62	1.92 ± 0.42	Pass
DW-20014,20015	1/29/2020	Ra-228	3.34 ± 0.74	2.25 ± 0.70	2.80 ± 0.51	Pass
DW-20014,20015	1/29/2020	Ra-226	1.05 ± 0.15	0.64 ± 0.24	0.85 ± 0.14	Pass
S-209,210	1/31/2020	K-40	8.28 ± 0.20	7.95 ± 0.42	8.12 ± 0.23	Pass
LW-383,384	1/31/2020	Gr. Beta	1.67 ± 0.58	0.77 ± 0.52	1.22 ± 0.39	Pass
AP-020320A,B	2/3/2020	Gr. Beta	0.021 ± 0.004	0.024 ± 0.004	0.023 ± 0.003	Pass
S-362,363	2/7/2020	Pb-214	2.39 ± 0.11	2.25 ± 0.10	2.32 ± 0.07	Pass
S-362,363	2/7/2020	Ac-228	1.84 ± 0.18	1.95 ± 0.17	1.90 ± 0.12	Pass
DW-20018,20019	2/7/2020	Gr. Alpha	0.23 ± 0.86	0.37 ± 0.88	0.30 ± 0.62	Pass
DW-20018,20019	2/7/2020	Gr. Beta	0.50 ± 0.56	1.19 ± 0.63	0.85 ± 0.42	Pass
DW-20026,20027	2/7/2020	Ra-226	2.40 ± 0.21	2.11 ± 0.15	2.26 ± 0.13	Pass
DW-20026,20027	2/7/2020	Ra-228	2.60 ± 0.68	1.81 ± 0.57	2.21 ± 0.44	Pass
WW-452,453	2/17/2020	H-3	583 ± 102	678 ± 106	630 ± 74	Pass
DW-20031,20032	2/25/2020	Gr. Alpha	1.02 ± 0.77	0.80 ± 0.81	0.91 ± 0.56	Pass
DW-20031,20032	2/25/2020	Gr. Beta	1.11 ± 0.59	1.19 ± 0.58	1.15 ± 0.41	Pass
DW-20038,20039	3/3/2020	Ra-226	8.39 ± 0.43	8.78 ± 0.49	8.59 ± 0.33	Pass
DW-20038,20039	3/3/2020	Ra-228	2.81 ± 1.00	2.31 ± 0.86	2.56 ± 0.66	Pass
WW-752,753	3/13/2020	H-3	435 ± 94	393 ± 92	414 ± 66	Pass
S-868,869	3/13/2020	Pb-214	0.97 ± 0.10	0.99 ± 0.09	0.98 ± 0.07	Pass
S-868,869	3/13/2020	Ac-228	0.93 ± 0.18	1.01 ± 0.23	0.97 ± 0.15	Pass
LW-977,978	3/25/2020	Gr. Beta	0.98 ± 0.53	0.92 ± 0.51	0.95 ± 0.37	Pass
AP-1220,1221	3/31/2020	Be-7	0.063 ± 0.011	0.062 ± 0.013	0.063 ± 0.009	Pass
SWT-912,913	3/31/2020	Gr. Beta	0.79 ± 0.53	0.49 ± 0.50	0.64 ± 0.37	Pass
AP-956,957	4/2/2020	Be-7	0.189 ± 0.097	0.256 ± 0.130	0.222 ± 0.081	Pass
AP-1110,1111	4/3/2020	Be-7	0.069 ± 0.012	0.072 ± 0.013	0.071 ± 0.009	Pass
WW-1047,1048	4/7/2020	H-3	438 ± 96	478 ± 98	458 ± 69	Pass
VE-1022,1023	4/8/2020	Be-7	9.28 ± 0.57	8.00 ± 0.62	8.64 ± 0.42	Pass
VE-1022,1023	4/8/2020	K-40	3.89 ± 0.67	3.94 ± 0.73	3.92 ± 0.49	Pass
S-1199,1200	4/12/2020	Pb-214	0.77 ± 0.07	0.98 ± 0.08	0.88 ± 0.05	Pass
S-1199,1200	4/12/2020	Ac-228	1.09 ± 0.15	1.18 ± 0.17	1.14 ± 0.11	Pass
SS-1419,1420	4/14/2020	K-40	10.8 ± 0.6	9.4 ± 0.4	10.1 ± 0.4	Pass
AP-1241,1242	4/16/2020	Be-7	0.203 ± 0.113	0.245 ± 0.145	0.224 ± 0.092	Pass
DW-20051,20052	4/23/2020	Ra-228	3.50 ± 0.85	4.60 ± 0.89	4.05 ± 0.62	Pass
DW-20051,20052	4/23/2020	Ra-226	0.80 ± 0.10	0.60 ± 0.10	0.70 ± 0.07	Pass
SS-1310,1311	4/23/2020	K-40	7,827 ± 492	8,157 ± 505	7,992 ± 352	Pass
LW-1375,1376	4/29/2020	Gr. Beta	1.62 ± 0.59	1.61 ± 0.58	1.62 ± 0.41	Pass

TABLE A-6. Intralaboratory "Duplicate" Samples

Lab Code ^b	Date	Analysis	Concentration ^a		Averaged Result	Acceptance
			First Result	Second Result		
F-1828,1829	4/29/2020	K-40	1.35 ± 0.41	0.98 ± 0.33	1.16 ± 0.27	Pass
SG-1398,1399	5/5/2020	Pb-214	7.51 ± 0.19	8.62 ± 0.17	8.07 ± 0.13	Pass
SG-1398,1399	5/5/2020	Ac-228	6.80 ± 0.31	6.77 ± 0.27	6.79 ± 0.21	Pass
SW-1461,1462	5/7/2020	H-3	315 ± 88	320 ± 89	317 ± 63	Pass
AP-1610,1611	5/14/2020	Be-7	0.179 ± 0.101	0.172 ± 0.086	0.176 ± 0.066	Pass
DW-20062,20063	5/19/2020	Gr. Alpha	6.20 ± 1.30	5.00 ± 1.30	5.60 ± 0.92	Pass
DW-20062,20063	5/19/2020	Gr. Beta	6.09 ± 0.77	5.51 ± 0.72	5.80 ± 0.53	Pass
W-1805,1806	5/25/2020	Ra-226	0.42 ± 0.16	0.24 ± 0.17	0.33 ± 0.12	Pass
F-1763,1764	5/26/2020	K-40	2.82 ± 0.47	3.01 ± 0.45	2.92 ± 0.33	Pass
AP-052620A,B	5/26/2020	Gr. Beta	0.014 ± 0.003	0.016 ± 0.003	0.015 ± 0.002	Pass
DW-20066,20067	6/1/2020	Ra-226	0.21 ± 0.09	0.33 ± 0.12	0.27 ± 0.08	Pass
DW-20066,20067	6/1/2020	Ra-228	0.05 ± 0.43	0.03 ± 0.39	0.04 ± 0.29	Pass
P-1849,1850	6/1/2020	H-3	547 ± 102	700 ± 108	624 ± 74	Pass
AP-1893,1894	6/4/2020	Be-7	0.164 ± 0.080	0.251 ± 0.140	0.208 ± 0.081	Pass
SW-1872,1873	6/4/2020	H-3	385 ± 94	400 ± 95	393 ± 67	Pass
AP-052620A,B	6/8/2020	Gr. Beta	0.024 ± 0.004	0.025 ± 0.005	0.024 ± 0.003	Pass
WW-2025,2026	6/16/2020	H-3	318 ± 92	320 ± 92	319 ± 65	Pass
AP-061620A,B	6/16/2020	Gr. Beta	0.017 ± 0.003	0.019 ± 0.003	0.018 ± 0.002	Pass
DW-20078,20079	6/17/2020	Ra-226	0.53 ± 0.11	0.50 ± 0.10	0.52 ± 0.07	Pass
DW-20078,20079	6/17/2020	Ra-228	1.10 ± 0.50	1.11 ± 0.50	1.11 ± 0.35	Pass
AP-2048,2049	6/18/2020	Be-7	0.222 ± 0.087	0.221 ± 0.092	0.221 ± 0.063	Pass
SW-2157,2158	6/23/2020	H-3	175 ± 86	235 ± 89	205 ± 62	Pass
AP-062320A,B	6/23/2020	Gr. Beta	0.021 ± 0.003	0.023 ± 0.004	0.022 ± 0.003	Pass
AP-2136,2137	6/25/2020	Be-7	0.242 ± 0.099	0.343 ± 0.115	0.292 ± 0.076	Pass
AP-2366,2367	6/30/2020	Be-7	0.144 ± 0.018	0.177 ± 0.019	0.161 ± 0.013	Pass
SWU-2180,2181	6/30/2020	H-3	105 ± 82	199 ± 87	152 ± 60	Pass
AP-2473,2474	7/1/2020	Be-7	0.079 ± 0.011	0.089 ± 0.012	0.084 ± 0.008	Pass
AP-2473,2474	7/1/2020	K-40	0.010 ± 0.006	0.015 ± 0.009	0.013 ± 0.005	Pass
AP-2408,2409	7/2/2020	Be-7	0.084 ± 0.016	0.085 ± 0.014	0.085 ± 0.011	Pass
P-2264,2265	7/6/2020	H-3	149 ± 83	144 ± 83	147 ± 59	Pass
DW-20091,20092	7/10/2020	Ra-226	0.77 ± 0.17	0.69 ± 0.24	0.73 ± 0.15	Pass
DW-20091,20092	7/10/2020	Ra-228	0.61 ± 0.56	0.59 ± 0.55	0.60 ± 0.39	Pass
SW-2450,2451	7/14/2020	H-3	410 ± 96	487 ± 99	448 ± 69	Pass
VE-2494,2495	7/16/2020	K-40	1.68 ± 0.25	2.08 ± 0.26	1.88 ± 0.18	Pass
DW-20102,20103	7/17/2020	Gr. Alpha	1.98 ± 0.82	2.65 ± 0.82	2.32 ± 0.58	Pass
DW-20102,20103	7/17/2020	Ra-226	0.84 ± 0.20	0.89 ± 0.20	0.87 ± 0.14	Pass
DW-20102,20103	7/17/2020	Ra-228	1.24 ± 0.67	1.57 ± 0.70	1.41 ± 0.48	Pass
WW-2604,2605	7/20/2020	H-3	35,989 ± 576	36,039 ± 577	36,014 ± 408	Pass
SWU-2669,2670	7/28/2020	H-3	103 ± 80	101 ± 80	102 ± 57	Pass
SWU-2669,2670	7/28/2020	Gr. Beta	1.49 ± 0.56	1.05 ± 0.51	1.27 ± 0.38	Pass
S-2711,2712	7/29/2020	K-40	17.4 ± 0.9	19.6 ± 1.0	18.5 ± 0.7	Pass

TABLE A-6. Intralaboratory "Duplicate" Samples

Lab Code ^b	Date	Analysis	Concentration ^a		Averaged Result	Acceptance
			First Result	Second Result		
WW-2799,2800	8/4/2020	H-3	471 ± 100	437 ± 99	454 ± 70	Pass
WW-2933,2934	8/4/2020	H-3	316 ± 91	300 ± 90	308 ± 64	Pass
S-2774,2775	8/4/2020	K-40	5.9 ± 0.9	6.1 ± 0.8	6.0 ± 0.6	Pass
WW-2912,2913	8/5/2020	H-3	176 ± 84	226 ± 87	201 ± 60	Pass
F-3040,3041	8/7/2020	Gr. Beta	4.55 ± 0.12	4.63 ± 0.12	4.59 ± 0.09	Pass
F-3040,3041	8/7/2020	K-40	3.58 ± 0.42	3.32 ± 0.41	3.45 ± 0.29	Pass
WW-2867,2868	8/12/2020	H-3	169 ± 85	219 ± 86	194 ± 61	Pass
VE-2842,2843	8/12/2020	K-40	3.18 ± 0.30	3.14 ± 0.37	3.16 ± 0.24	Pass
F-2891,2892	8/14/2020	K-40	2.98 ± 0.39	2.82 ± 0.35	2.90 ± 0.26	Pass
VE-2954,2955	8/20/2020	Be-7	0.222 ± 0.106	0.283 ± 0.166	0.252 ± 0.099	Pass
VE-2954,2955	8/20/2020	K-40	4.09 ± 0.37	3.75 ± 0.38	3.92 ± 0.27	Pass
DW-20126,20127	8/25/2020	Ra-226	0.90 ± 0.14	0.73 ± 0.12	0.82 ± 0.09	Pass
DW-20126,20127	8/25/2020	Ra-228	1.55 ± 0.52	2.30 ± 0.58	1.93 ± 0.39	Pass
LW-3154,3155	8/26/2020	Gr. Beta	1.43 ± 0.60	1.33 ± 0.55	1.38 ± 0.41	Pass
VE-3084,3085	8/28/2020	Be-7	0.52 ± 0.12	0.48 ± 0.07	0.50 ± 0.07	Pass
VE-3084,3085	8/28/2020	K-40	3.87 ± 0.16	3.36 ± 0.31	3.62 ± 0.17	Pass
SWU-3133,3134	9/1/2020	H-3	107 ± 84	116 ± 84	111 ± 59	Pass
VE-3208,3209	9/8/2020	K-40	5.99 ± 0.43	5.85 ± 0.35	5.92 ± 0.28	Pass
VE-3187,3188	9/8/2020	Be-7	0.50 ± 0.17	0.61 ± 0.23	0.55 ± 0.14	Pass
VE-3187,3188	9/8/2020	K-40	4.64 ± 0.54	4.97 ± 0.45	4.81 ± 0.35	Pass
WW-3427,3428	9/10/2020	H-3	2,321 ± 163	2,323 ± 164	2,322 ± 116	Pass
DW-21033,21034	9/14/2020	Gr. Alpha	1.27 ± 0.79	0.94 ± 0.75	1.11 ± 0.54	Pass
DW-21033,21034	9/14/2020	Gr. Beta	1.02 ± 0.60	1.01 ± 0.59	1.02 ± 0.42	Pass
SG-3265,3266	9/14/2020	Pb-214	11.8 ± 0.49	10.4 ± 0.57	11.1 ± 0.38	Pass
SG-3265,3266	9/14/2020	Ac-228	18.8 ± 1.27	17.3 ± 1.36	18.0 ± 0.93	Pass
SG-3265,3266	9/14/2020	Gr. Alpha	28.0 ± 4.6	33.5 ± 4.9	30.8 ± 3.4	Pass
SG-3265,3266	9/14/2020	Gr. Beta	42.1 ± 2.8	44.5 ± 3.0	43.3 ± 2.1	Pass
VE-3315,3316	9/15/2020	Be-7	0.25 ± 0.10	0.28 ± 0.16	0.27 ± 0.09	Pass
VE-3315,3316	9/15/2020	K-40	5.48 ± 0.34	5.16 ± 0.36	5.32 ± 0.25	Pass
WW-3339,3340	9/16/2020	H-3	196 ± 85	199 ± 85	198 ± 60	Pass
CF-3381,3382	9/21/2020	Be-7	0.20 ± 0.10	0.19 ± 0.11	0.20 ± 0.07	Pass
CF-3381,3382	9/21/2020	K-40	5.94 ± 0.30	5.72 ± 0.29	5.83 ± 0.21	Pass
AP-092120A,B	9/21/2020	Gr. Beta	0.043 ± 0.005	0.041 ± 0.005	0.042 ± 0.004	Pass
F-3706,3707	9/26/2020	K-40	1.86 ± 0.35	1.83 ± 0.39	1.84 ± 0.26	Pass
AP-092820A,B	9/28/2020	Gr. Beta	0.021 ± 0.004	0.023 ± 0.004	0.022 ± 0.003	Pass
XW-3620,3621	9/30/2020	Sr-89	11,760 ± 140	12,487 ± 133	12,124 ± 97	Pass
XW-3620,3621	9/30/2020	Sr-90	2,287 ± 45	2,831 ± 50	2,559 ± 34	Pass
XW-3620,3621	9/30/2020	Fe-55	1,623 ± 462	1,833 ± 474	1,728 ± 331	Pass

TABLE A-6. Intralaboratory "Duplicate" Samples

Lab Code ^b	Date	Analysis	Concentration ^a		Averaged Result	Acceptance
			First Result	Second Result		
SW-3515,3516	10/1/2020	H-3	154 ± 86	111 ± 84	133 ± 60	Pass
DW-20141,20142	10/1/2020	Ra-226	1.34 ± 0.16	1.39 ± 0.16	1.37 ± 0.11	Pass
DW-20141,20142	10/1/2020	Ra-228	1.74 ± 0.62	2.09 ± 0.64	1.92 ± 0.45	Pass
SW-3536,3537	10/5/2020	H-3	376 ± 97	378 ± 97	377 ± 68	Pass
WW-3727,3728	10/8/2020	H-3	152 ± 82	190 ± 84	171 ± 59	Pass
VE-3748,3749	10/12/2020	K-40	3.07 ± 0.25	2.88 ± 0.26	2.98 ± 0.18	Pass
VE-3769,3770	10/12/2020	Be-7	0.80 ± 0.31	0.51 ± 0.15	0.66 ± 0.17	Pass
VE-3769,3770	10/12/2020	K-40	5.69 ± 0.61	5.79 ± 0.39	5.74 ± 0.36	Pass
WW-4092,4093	10/13/2020	H-3	6,484 ± 252	6,275 ± 248	6,380 ± 177	Pass
WW-3838,3839	10/14/2020	H-3	313 ± 90	263 ± 88	288 ± 63	Pass
WW-4394,4395	11/3/2020	H-3	161 ± 83	199 ± 85	180 ± 60	Pass
WW-4587,4588	11/4/2020	H-3	6,468 ± 252	6,638 ± 255	6,553 ± 179	Pass
WW-4524,4525	11/5/2020	H-3	160 ± 86	131 ± 84	145 ± 60	Pass
VE-4415,4416	11/24/2020	Be-7	0.28 ± 0.08	0.22 ± 0.07	0.25 ± 0.05	Pass
VE-4415,4416	11/24/2020	K-40	2.25 ± 0.21	2.20 ± 0.19	2.23 ± 0.14	Pass
AP-4845,4846	12/31/2020	Be-7	0.07 ± 0.01	0.06 ± 0.02	0.06 ± 0.01	Pass

Note: Duplicate analyses are performed on every twentieth sample received. Results are not listed for those analyses with activities that measure below the LLD.

^a Results are reported in units of pCi/L, except for air filters (pCi/Filter or pCi/m³), food products, vegetation, soil and sediment (pCi/g).

^b AP (Air Particulate), AV (Aquatic Vegetation), BS (Bottom Sediment), CF (Cattle Feed), CH (Charcoal Canister), DW (Drinking Water), E (Egg), F (Fish), G (Grass), LW (Lake Water), MI (Milk), P (Precipitation), PM (Powdered Milk), S (Solid), SG (Sludge), SO (Soil), SS (Shoreline Sediment), SW (Surface Water), SWT (Surface Water Treated), SWU (Surface Water Untreated), VE (Vegetation), W (Water), WW (Well Water).

TABLE A-7. Department of Energy's Mixed Analyte Performance Evaluation Program (MAPEP).

Lab Code ^b	Reference Date	Analysis	Laboratory result	Concentration ^a		Acceptance
				Known Activity	Control Limits ^c	
MAAP-664	2/1/2020	Gross Alpha	2.26 ± 0.14	1.24	0.37 - 2.11	Fail ^d
MAAP-664	2/1/2020	Gross Beta	2.40 ± 0.07	2.00	1.00 - 3.00	Pass
MAW-536	2/1/2020	Gross Alpha	0.86 ± 0.06	1.03	0.31 - 1.75	Pass
MAW-536	2/1/2020	Gross Beta	3.79 ± 0.07	4.24	2.12 - 6.36	Pass
MASO-662	2/1/2020	Cs-134	955 ± 9	1114	780 - 1448	Pass
MASO-662	2/1/2020	Cs-137	1089 ± 12	1020	714 - 1326	Pass
MASO-662	2/1/2020	Co-57	1106 ± 8	1071	750 - 1392	Pass
MASO-662	2/1/2020	Co-60	0.33 ± 1.26	0	NA ^c	Pass
MASO-662	2/1/2020	Mn-54	1022 ± 27	945	662 - 1229	Pass
MASO-662	2/1/2020	Zn-65	842 ± 17	751	526 - 976	Pass
MASO-662	2/1/2020	K-40	710 ± 42	625	438 - 813	Pass
MAW-534	2/1/2020	I-129	0.81 ± 0.09	1.001	0.701 - 1.301	Pass
MAW-599	2/1/2020	H-3	202 ± 9	196	137 - 255	Pass
MAW-599	2/1/2020	Am-241	0.41 ± 0.09	0.547	0.383 - 0.711	Pass
MAW-599	2/1/2020	Cs-134	16.1 ± 0.3	18.5	13.0 - 24.1	Pass
MAW-599	2/1/2020	Cs-137	11.5 ± 0.4	11.3	7.9 - 14.7	Pass
MAW-599	2/1/2020	Co-57	20.0 ± 0.30	19.7	13.8 - 25.6	Pass
MAW-599	2/1/2020	Co-60	10.6 ± 0.2	10.6	7.4 - 13.8	Pass
MAW-599	2/1/2020	Mn-54	20.5 ± 0.4	19.6	13.7 - 25.5	Pass
MAW-599	2/1/2020	Zn-65	24.1 ± 0.70	22.2	15.5 - 28.9	Pass
MAW-599	2/1/2020	K-40	0.57 ± 1.54	0	NA ^c	Pass
MAW-599	2/1/2020	Fe-55	13.3 ± 12.2	17.8	12.5 - 23.1	Pass
MAW-599	2/1/2020	Ni-63	9.72 ± 0.43	11.1	7.8 - 14.4	Pass
MAW-599	2/1/2020	Sr-90	0.07 ± 0.18	0	NA ^c	Pass
MAW-599	2/1/2020	Tc-99	3.41 ± 0.31	3.63	2.54 - 4.72	Pass
MAW-599	2/1/2020	Ra-226	0.56 ± 0.06	0.365	0.256 - 0.475	Fail ^e
MAW-599	2/1/2020	Pu-238	0.69 ± 0.08	0.94	0.66 - 1.22	Pass
MAW-599	2/1/2020	Pu-239/240	0.48 ± 0.07	0.737	0.516 - 0.958	Fail ^f
MAW-599	2/1/2020	U-234	1.04 ± 0.08	0.97	0.68 - 1.26	Pass
MAW-599	2/1/2020	U-238	1.02 ± 0.08	0.95	0.67 - 1.24	Pass

TABLE A-7. Department of Energy's Mixed Analyte Performance Evaluation Program (MAPEP).

Lab Code ^b	Reference Date	Analysis	Concentration ^a			Acceptance
			Laboratory result	Known Activity	Control Limits ^c	
MAVE-668	2/1/2020	Cs-134	3.51 ± 0.22	3.82	2.67 - 4.97	Pass
MAVE-668	2/1/2020	Cs-137	3.04 ± 0.18	2.77	1.94 - 3.60	Pass
MAVE-668	2/1/2020	Co-57	0.02 ± 0.03	0	NA ^c	Pass
MAVE-668	2/1/2020	Co-60	2.92 ± 0.08	2.79	1.95 - 3.63	Pass
MAVE-668	2/1/2020	Mn-54	5.16 ± 0.14	4.58	3.21 - 5.95	Pass
MAVE-668	2/1/2020	Zn-65	4.36 ± 0.16	3.79	2.65 - 4.93	Pass
MAW-689	2/1/2020	Ra-226	172 ± 1	189	132 - 246	Pass
MAW-689	2/1/2020	Ra-228	65 ± 1	75	53 - 98	Pass
MAAP-3181	8/1/2020	Gross Alpha	0.45 ± 0.06	0.528	0.158 - 0.898	Pass
MAAP-3181	8/1/2020	Gross Beta	0.97 ± 0.04	0.915	0.458 - 1.373	Pass
MADW-3101	8/1/2020	Gross Alpha	0.57 ± 0.04	0.62	0.19 - 1.05	Pass
MADW-3101	8/1/2020	Gross Beta	0.75 ± 0.04	0.83	0.42 - 1.25	Pass
MASO-3179	8/1/2020	Cs-134	599 ± 7	710	497 - 923	Pass
MASO-3179	8/1/2020	Cs-137	3.33 ± 4.81	0	NA ^c	Pass
MASO-3179	8/1/2020	Co-57	1145 ± 8	1100	770 - 1430	Pass
MASO-3179	8/1/2020	Co-60	965 ± 9	1000	700 - 1300	Pass
MASO-3179	8/1/2020	Mn-54	651 ± 11	610	427 - 793	Pass
MASO-3179	8/1/2020	Zn-65	524 ± 14	470	329 - 611	Pass
MASO-3179	8/1/2020	K-40	684 ± 58	622	435 - 809	Pass
MAW-3175	8/1/2020	Cs-134	13.9 ± 0.3	15.2	10.6 - 19.8	Pass
MAW-3175	8/1/2020	Cs-137	15.4 ± 0.4	14.3	10.0 - 18.6	Pass
MAW-3175	8/1/2020	Co-57	0.10 ± 0.16	0	NA ^c	Pass
MAW-3175	8/1/2020	Co-60	12.5 ± 0.3	12.2	8.5 - 15.9	Pass
MAW-3175	8/1/2020	Mn-54	0.07 ± 0.17	0	NA ^c	Pass
MAW-3175	8/1/2020	Zn-65	18.3 ± 0.6	16.9	11.8 - 22.0	Pass
MAW-3175	8/1/2020	K-40	1.06 ± 1.65	0	NA ^c	Pass

TABLE A-7. Department of Energy's Mixed Analyte Performance Evaluation Program (MAPEP).

Lab Code ^b	Reference Date	Analysis	Laboratory result	Concentration ^a		Acceptance
				Known Activity	Control Limits ^c	
MAAP-3177	8/1/2020	Cs-134	1.28 ± 0.05	1.83	1.28 - 2.38	Fail ^g
MAAP-3177	8/1/2020	Cs-137	0.981 ± 0.068	0.996	0.697 - 1.295	Pass
MAAP-3177	8/1/2020	Co-57	0.020 ± 0.027	0	NA ^c	Pass
MAAP-3177	8/1/2020	Co-60	1.57 ± 0.06	1.73	1.21 - 2.25	Pass
MAAP-3177	8/1/2020	Mn-54	0.751 ± 0.077	1.400	0.98 - 1.82	Fail ^h
MAAP-3177	8/1/2020	Zn-65	2.07 ± 0.15	2.00	1.40 - 2.60	Pass
MAVE-3185	8/1/2020	Cs-134	4.73 ± 0.10	4.94	3.46 - 6.42	Pass
MAVE-3185	8/1/2020	Cs-137	0.03 ± 0.06	0	NA ^c	Pass
MAVE-3185	8/1/2020	Co-57	7.83 ± 0.12	6.67	4.67 - 8.67	Pass
MAVE-3185	8/1/2020	Co-60	4.41 ± 0.10	4.13	2.89 - 5.37	Pass
MAVE-3185	8/1/2020	Mn-54	6.52 ± 0.18	5.84	4.09 - 7.59	Pass
MAVE-3185	8/1/2020	Zn-65	7.26 ± 0.19	6.38	4.47 - 8.29	Pass

^a Results are reported in units of Bq/kg (soil), Bq/L (water) or Bq/total sample (filters, vegetation).

^b Laboratory codes as follows: MAW (water), MADW (water), MAAP (air filter), MASO (soil) and MAVE (vegetation).

^c MAPEP results are presented as the known values and expected laboratory precision (1 sigma, 1 determination) and control limits as defined by the MAPEP. A known value of "zero" indicates an analysis was included in the testing series as a "false positive". MAPEP does not provide control limits.

^d The lab utilized a MAPEP specific gross alpha/beta filter calibration as discussed in the MAPEP test instructions for MAAP-664. Using the MAPEP specific calibration for MAAP-664 caused the bias to shift from low to high. The subsequent MAPEP study result was acceptable. See Lab code MAAP-3101 (reference date 8/1/2020).

^e An investigation of the Radium-226 failure was inconclusive. Subsequent Ra-226 PT analyses were satisfactory. See ERA RAD-121 and RAD-122 studies Table A-1 and NY ELAP shipment 437R Table A-2.

^f Analysis was repeated in duplicate with acceptable results: Pu-238 (0.97 & 1.10 Bq/Kg); Pu-239 (0.83 & 0.83 Bq/Kg). The cause of the failure could not be determined.

^g Lab result barely missed lower control limit.

^h A data transcription error resulted in an erroneous reported value. The actual result (1.36 ± 0.08 Bq/L) passes.

TABLE A-8. Interlaboratory Comparison Crosscheck Program, Environmental Resource Associates (ERA)^a.

MRAD-30 Study						
Lab Code ^b	Date	Analysis	Concentration ^a		Control Limits ^d	Acceptance
			Laboratory Result	ERA Value ^c		
ERAP-769	3/16/2020	Am-241	71.0	74.7	53.3 - 99.6	Pass
ERAP-769	3/16/2020	Cs-134	1210	1390	902 - 1700	Pass
ERAP-769	3/16/2020	Cs-137	393	351	288 - 460	Pass
ERAP-769	3/16/2020	Co-60	450.0	422.0	359.0 - 536	Pass
ERAP-769	3/16/2020	Fe-55	1200	1260	460 - 2010	Pass
ERAP-769	3/16/2020	Mn-54	< 2.4	< 50.0	0.00 - 50.0	Pass
ERAP-769	3/16/2020	Zn-65	856	694	569 - 1060	Pass
ERAP-769	3/16/2020	Pu-238	31.4	28.0	21.1 - 34.4	Pass
ERAP-769	3/16/2020	Pu-239	43.9	40.1	30.0 - 48.4	Pass
ERAP-769	3/16/2020	Sr-90	190	175	111 - 238	Pass
ERAP-769	3/16/2020	U-234	56.7	56.2	41.7 - 65.9	Pass
ERAP-769	3/16/2020	U-238	57.0	55.7	42.1 - 66.5	Pass
ERAP-771	3/16/2020	Gross Alpha	33.4	29.3	15.3 - 48.3	Pass
ERAP-771	3/16/2020	Gross Beta	68.3	66.4	40.3 - 100	Pass

^a Results obtained by Environmental, Inc., Midwest Laboratory (EIML) as a participant in the crosscheck program for proficiency testing administered by Environmental Resource Associates, serving as a replacement for studies conducted previously by the Environmental Measurements Laboratory Quality Assessment Program (EML).

^b Laboratory code ERAP (air filter). Results are reported in units of (pCi/Filter).

^c The ERA Assigned values for the air filter standards are equal to 100% of the parameter present in the standard as determined by the gravimetric and/or volumetric measurements made during standard preparation as applicable.

^d The acceptance limits are established per the guidelines contained in the Department of Energy (DOE) report EML-564, Analysis of Environmental Measurements Laboratory (EML) Quality Assessment Program (QAP) Data Determination of Operational Criteria and Control Limits for Performance Evaluation Purposes or ERA's SOP for the generation of Performance Acceptance Limits.

APPENDIX B

DATA REPORTING CONVENTIONS

Data Reporting Conventions

1.0. All activities, except gross alpha and gross beta, are decay corrected to collection time or the end of the collection period.

2.0. Single Measurements

Each single measurement is reported as follows: $x \pm s$

where: x = value of the measurement;

s = $2s$ counting uncertainty (corresponding to the 95% confidence level).

In cases where the activity is less than the lower limit of detection L , it is reported as: $<L$,

where L = the lower limit of detection based on 4.66s uncertainty for a background sample.

3.0. Duplicate analyses

3.1 Individual results: For two analysis results; $x_1 \pm s_1$ and $x_2 \pm s_2$

Reported result: $x \pm s$; where $x = (1/2)(x_1 + x_2)$ and $s = (1/2) \sqrt{s_1^2 + s_2^2}$

3.2. Individual results: $<L_1$, $<L_2$ Reported result: $<L$, where L = lower of L_1 and L_2

3.3. Individual results: $x \pm s$, $<L$ Reported result: $x \pm s$ if $x \geq L$; $<L$ otherwise.

4.0. Computation of Averages and Standard Deviations

- 4.1 Averages and standard deviations listed in the tables are computed from all of the individual measurements over the period averaged; for example, an annual standard deviation would not be the average of quarterly standard deviations. The average \bar{x} and standard deviation s of a set of n numbers $x_1, x_2 \dots x_n$ are defined as follows:

$$\bar{x} = \frac{1}{n} \sum x \qquad s = \sqrt{\frac{\sum (x - \bar{x})^2}{n-1}}$$

- 4.2 Values below the highest lower limit of detection are not included in the average.

- 4.3 If all values in the averaging group are less than the highest LLD, the highest LLD is reported.

- 4.4 If all but one of the values are less than the highest LLD, the single value x and associated two sigma error is reported.

- 4.5 In rounding off, the following rules are followed:

4.5.1. If the figure following those to be retained is less than 5, the figure is dropped, and the retained figures are kept unchanged. As an example, 11.443 is rounded off to 11.44.

4.5.2. If the figure following those to be retained is equal to or greater than 5, the figure is dropped and the last retained figure is raised by 1. As an example, 11.445 is rounded off to 11.45.

- 4.6 Composite samples which overlap the next month or year are reported for the month or year in which most of the sample is collected.

APPENDIX C

SAMPLE LOCATION MAPS

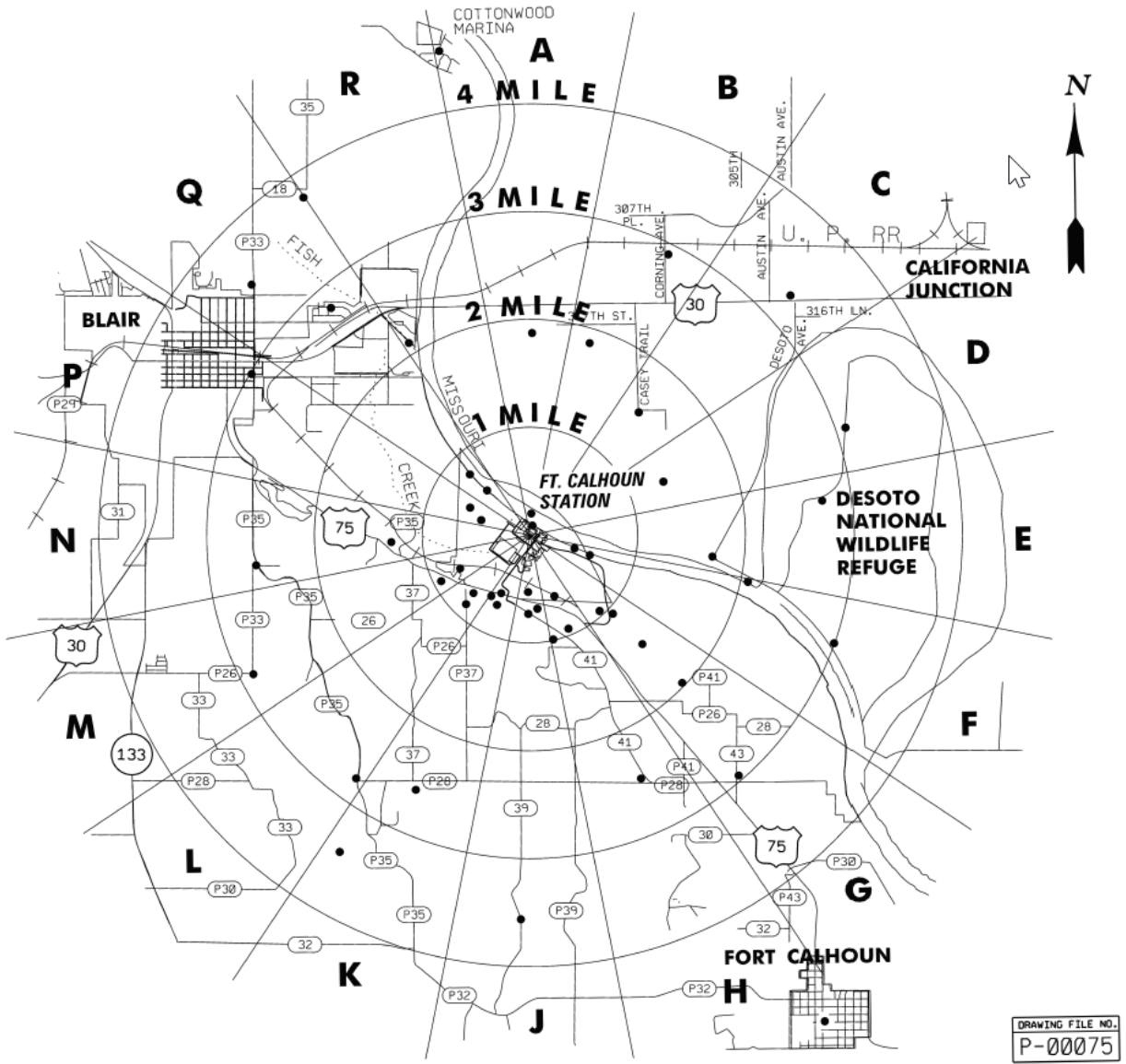

Radiological Environmental Sampling Locations and Media

Table 5.2 - Radiological Environmental Sampling Locations And Media

Sample Station No.	Approximate Collection Sites	Approximate Distance from Center of Containment (miles)	Approximate Direction (degrees from true north)	Sector	Air Monitoring		TLD	Water	Milk	Sedi-ment	Fish	Vegetables and Food Products	Ground-water
					Airborne Particulate								
1	Onsite Station, 110-meter weather tower	0.53	293°/WNW	P			X						
2 ^{C,E}	Onsite Station, adjacent to old plant access road	0.59	207°/SSW	K		X	X						
3	Offsite Station, Intersection of Hwy. 75 and farm access road	0.94	145°/SE	G			X						
4	Blair OPPD office	2.86	305°/NW	Q		X	X						
5 ^A													
6	Fort Calhoun, NE City Hall	5.18	150°/SSE	H			X						

Radiological Environmental Sampling Locations and Media

Table 5.2 - Radiological Environmental Sampling Locations And Media

Sample Station No.	Approximate Collection Sites	Approximate Distance from Center of Containment (miles)	Approximate Direction (degrees from true north)	Sector	Air Monitoring		TLD	Water	Milk	Sedi-ment	Fish	Vegetables and Food Products	Ground-water
						Airborne Particulate							
7	Fence around intake gate, Desoto Wildlife Refuge	2.07	102°/ESE	F			X						
8	Onsite Station, entrance to Plant Site from Hwy. 75	0.55	191°/S	J			X						
9	Onsite Station, NW of Plant	0.68	305°/NW	Q			X						
10	Onsite Station, WSW of Plant	0.61	242°/WSW	M			X						
11	Offsite Station, SE of Plant	1.07	39°/SE	G			X						

Radiological Environmental Sampling Locations and Media

Table 5.2 - Radiological Environmental Sampling Locations And Media

Sample Station No.	Approximate Collection Sites	Approximate Distance from Center of Containment (miles)	Approximate Direction (degrees from true north)	Sector	Air Monitoring		TLD	Water	Milk	Sedi-ment	Fish	Vegetables and Food Products	Ground-water
						Airborne Particulate							
12	Metropolitan Utilities Dist., Florence Treatment Plant North Omaha, NE	14.3	154°/SSE	H				X					
13	West bank Missouri River, downstream from Plant discharge	0.45	108°/ESE	F				X		X			
14 ^D	Upstream from Intake Bldg, west bank of river	0.09	4°/N	A				X		X			
15	Smith Farm	1.99	134°/SE	G									X
16 ^A													
17 ^A													

Radiological Environmental Sampling Locations and Media

Table 5.2 - Radiological Environmental Sampling Locations And Media

Sample Station No.	Approximate Collection Sites	Approximate Distance from Center of Containment (miles)	Approximate Direction (degrees from true north)	Sector	Air Monitoring		TLD	Water	Milk	Sedi-ment	Fish	Vegetables and Food Products	Ground-water
					Airborne Particulate								
18 ^A													
19 ^A													
20 ^{B,D,F}	Mohr Dairy	9.86	186°/S	J				X				X	X
21 ^A													
22	Fish Sampling Area, Missouri River	0.08 (R.M. 645.0)	6°/N	A							X		
23 ^D	Fish Sampling Area, Missouri River	17.9 (R.M. 666.0)	358°/N	A							X		
24 ^A													
25 ^A													
26 ^A													
27 ^A													

Radiological Environmental Sampling Locations and Media

Table 5.2 - Radiological Environmental Sampling Locations And Media

Sample Station No.	Approximate Collection Sites	Approximate Distance from Center of Containment (miles)	Approximate Direction (degrees from true north)	Sector	Air Monitoring		TLD	Water	Milk	Sedi-ment	Fish	Vegetables and Food Products	Ground-water
					Airborne Particulate								
28	Alvin Pechnik Farm	0.94	163	H								X	
29 ^A													
30 ^A													
31 ^A													
32 ^D	Valley Substation #902	19.6	221°/SW	L	X		X						
33 ^A													
34 ^A													
35	Onsite Farm Field	0.52	118°/ESE	F								X	
36	Offsite Station Intersection Hwy 75/Co. Rd. P37	0.75	227°/SW	L			X						

Radiological Environmental Sampling Locations and Media

Table 5.2 - Radiological Environmental Sampling Locations And Media

Sample Station No.	Approximate Collection Sites	Approximate Distance from Center of Containment (miles)	Approximate Direction (degrees from true north)	Sector	Air Monitoring		TLD	Water	Milk	Sedi-ment	Fish	Vegetables and Food Products	Ground-water
					Airborne Particulate								
37	Offsite Station Desoto Township	1.57	144°/SE	G	X		X						
38 ^A													
39 ^A													
40 ^A													
41 ^{B,C}	Dowler Acreage	0.73	175°/S	J	X		X						
42	Sector A-1	1.94	0°/NORTH	A			X						
43	Sector B-1	1.97	16°/NNE	B			X						
44	Sector C-1	1.56	41°/NE	C			X						
45	Sector D-1	1.34	71°/ENE	D			X						
46	Sector E-1	1.54	90°/EAST	E			X						
47	Sector F-1	0.45	108°/ESE	F			X						

Radiological Environmental Sampling Locations and Media

Table 5.2 - Radiological Environmental Sampling Locations And Media

Sample Station No.	Approximate Collection Sites	Approximate Distance from Center of Containment (miles)	Approximate Direction (degrees from true north)	Sector	Air Monitoring		TLD	Water	Milk	Sedi-ment	Fish	Vegetables and Food Products	Ground-water
						Airborne Particulate							
48	Sector G-1	1.99	134°/SE	G			X						
49	Sector H-1	1.04	159°/SSE	H			X						
50	Sector J-1	0.71	179°/SOUTH	J			X						
51	Sector K-1	0.61	205°/SSW	K			X						
52	Sector L-1	0.74	229°/SW	L			X						
53	Sector M-1	0.93	248°/WSW	M			X						
54	Sector N-1	1.31	266°/WEST	N			X						
55	Sector P-1	0.60	291°/WNNW	P			X						
56	Sector Q-1	0.67	307°/NW	Q			X						
57	Sector R-1	2.32	328°/NNW	R			X						
58 ^D	Sector A-2	4.54	350°/NORTH	A			X						
59 ^D	Sector B-2	2.95	26°/NNE	B			X						

Radiological Environmental Sampling Locations and Media

Table 5.2 - Radiological Environmental Sampling Locations And Media

Sample Station No.	Approximate Collection Sites	Approximate Distance from Center of Containment (miles)	Approximate Direction (degrees from true north)	Sector	Air Monitoring		TLD	Water	Milk	Sedi-ment	Fish	Vegetables and Food Products	Ground-water
						Airborne Particulate							
60 ^D	Sector C-2	3.32	50°/NE	C			X						
61 ^D	Sector D-2	3.11	75°/ENE	D			X						
62 ^D	Sector E-2	2.51	90°/EAST	E			X						
63 ^D	Sector F-2	2.91	110°/ESE	F			X						
64 ^D	Sector G-2	3.00	140°/SE	G			X						
65 ^D	Sector H-2	2.58	154°/SSE	H			X						
66 ^D	Sector J-2	3.53	181°/SOUTH	J			X						
67 ^D	Sector K-2	2.52	205°/SSW	K			X						
68 ^D	Sector L-2	2.77	214°/SW	L			X						
69 ^D	Sector M-2	2.86	243°/WSW	M			X						

Radiological Environmental Sampling Locations and Media

Table 5.2 - Radiological Environmental Sampling Locations And Media

Sample Station No.	Approximate Collection Sites	Approximate Distance from Center of Containment (miles)	Approximate Direction (degrees from true north)	Sector	Air Monitoring		TLD	Water	Milk	Sedi-ment	Fish	Vegetables and Food Products	Ground-water
						Airborne Particulate							
70 ^D	Sector N-2	2.54	263°/WEST	N			X						
71 ^D	Sector P-2	2.99	299°/WNW	P			X						
72 ^D	Sector Q-2	3.37	311°/NW	Q			X						
73 ^D	Sector R-2	3.81	328°/NNW	R			X						
74	D. Miller Farm	0.65	203°/SSW	K									X
75 ^{B,C}	Lomp Acreage	0.65	163°/SSE	H		X	X						X
76 ^A													
77 ^G	River N-1	0.17	328°/NNW	R			X						
78 ^G	River S-1	0.14	85°/EAST	E			X						
79 ^G	Lagoon S-1	0.24	131°/SE	G			X						
80 ^G	Parking S-1	0.27	158°/SSE	H			X						
81 ^G	Training W-1	0.28	194°/SSW	K			X						

Radiological Environmental Sampling Locations and Media

Table 5.2 - Radiological Environmental Sampling Locations And Media

Sample Station No.	Approximate Collection Sites	Approximate Distance from Center of Containment (miles)	Approximate Direction (degrees from true north)	Sector	Air Monitoring		TLD	Water	Milk	Sedi-ment	Fish	Vegetables and Food Products	Ground-water
						Airborne Particulate							
82 ^G	Switchyard S-1	0.21	219°/SW	L			X						
83 ^G	Switchyard SE-1	0.14	231°/SW	L			X						
84 ^G	Switchyard NE-1	0.18	256°/WSW	M			X						
85 ^G	Switchyard W-1	0.29	233°/WEST	L			X						
86 ^G	Switchyard N-1	0.24	262°/WEST	N			X						
87 ^G	Range S-1	0.20	286°/WNW	P			X						
88 ^G	Mausoleum E-1	0.37	216°/SW	L			X						
89	C, Miller	3.30	210°/SSW	K					X				

Radiological Environmental Sampling Locations and Media

NOTES:

- A. Location is either not in use or currently discontinued and is documented in the table for reference only.
- B. If milk samples are temporarily not available at a sampling site due to mitigating circumstances, then vegetation (broadleaf, pasture grass, etc.) shall be collected as an alternate sample at the site. If there are no milk producers within the entire 5-mile radius of the facility, then vegetation shall be collected monthly, when available, at two offsite locations having the highest calculated annual average ground level D/Q and a background locale. (Reference Off-Site Dose Calculation Manual, Part II, Table 4 "Highest Potential Exposure Pathways for Estimating Dose")
- C. Locations represent highest potential exposure pathways as determined by the biennial Land Use Survey, performed in accordance with Part I, Section 7.3.2, of the Off-Site Dose Calculation Manual and are monitored as such.
- D. Background location (control). All other locations are indicators.
- E. Location for monitoring Sector K High Exposure Pathway Resident Receptor for inhalation.
- F. When broad leaf (pasture grasses) are being collected in lieu of milk, background broad leaf samples will be collected at a background locale.
- G. Location for special interest monitoring general dose to the public per 40CFR190 (Figure 2)