



**UNITED STATES
NUCLEAR REGULATORY COMMISSION**

REGION III
2443 WARRENVILLE RD. SUITE 210
LISLE, IL 60532-4352

August 31, 2017

EA-17-114

Mr. Bryan C. Hanson
Senior VP, Exelon Generation Company, LLC
President and CNO, Exelon Nuclear
4300 Winfield Road
Warrenville, IL 60555

SUBJECT: LASALLE COUNTY STATION, UNITS 1 AND 2—SPECIAL INSPECTION
TEAM REPORT AND EXERCISE OF DISCRETION; INSPECTION
REPORT 05000373/2017009; 05000374/2017009

Dear Mr. Hanson:

On June 9, 2017, the U.S. Nuclear Regulatory Commission (NRC) completed a reactive inspection pursuant to Inspection Procedure 93812, "Special Inspection," at your LaSalle County Station. The enclosed inspection report documents the inspection results, which were discussed on June 9, 2017, and on July 21, 2017, with Mr. Trafton and other members of your staff.

The special inspection was commenced on April 24, 2017, in accordance with NRC Management Directive 8.3, "NRC Incident Investigation Program," and Inspection Manual Chapter 0309, "Reactive Inspection Decisions Basis for Reactors," based on the initial risk and deterministic criteria evaluation performed by NRC. The special inspection reviewed the circumstances surrounding the February 11, 2017, Unit 2 high pressure core spray injection valve (2E22-F004) stem-to-disc separation identified during a system fill and vent activity. The inspectors examined activities conducted under your license as they related to safety and compliance with the Agency's rules and regulations and with the conditions of your license.

No findings were identified during this inspection. A violation related to inadequate design control for the Unit 1 and Unit 2 high pressure core spray injection valves was identified. However, the NRC is exercising enforcement discretion by not issuing enforcement action for the underlying Title 10 of the *Code of Federal Regulations*, Part 50, Appendix B, Criterion III, "Design Control," violation based upon no associated performance deficiency and other factors as discussed within the report.

This letter, its enclosure, and your response (if any) will be made available for public inspection and copying at <http://www.nrc.gov/reading-rm/adams.html> and at the NRC Public Document Room in accordance with 10 CFR 2.390, "Public Inspections, Exemptions, Requests for Withholding."

Sincerely,

/RA Mohammed Shuaibi Acting for/

Kenneth G. O'Brien, Director
Division of Reactor Safety

Docket Nos. 50-373; 50-374
License Nos. NPF-11; NPF-18

Enclosure:
IR 05000373/2017009; 05000374/2017009

cc: Distribution via LISTSERV®

Letter to Bryan C. Hanson from Kenneth G. O'Brien dated August 31, 2017

SUBJECT: LASALLE COUNTY STATION, UNITS 1 AND 2—SPECIAL INSPECTION
TEAM REPORT AND EXERCISE OF DISCRETION; INSPECTION
REPORT 05000373/2017009; 05000374/2017009

DISTRIBUTION:

Jeremy Bowen
RidsNrrDorLpl3
RidsNrrPMLaSalle
RidsNrrDirslrib Resource
Cynthia Pederson
James Trapp
Richard Skokowski
Allan Barker
Carole Ariano
Linda Linn
DRPIII
DRSIII
ROPreports.Resource@nrc.gov

ADAMS Accession Number ML17243A098

OFFICE	RIII	RIII	RIII	RIII
NAME	JBenjamin:cl	KLambert for RSkokowski	MJeffers	MShuaibi for KO'Brien
DATE	08/17/17	08/17/17	08/21/17	08/31/17

OFFICIAL RECORD COPY

U.S. NUCLEAR REGULATORY COMMISSION

REGION III

Docket Nos: 05000373; 05000374
License Nos: NPF-11; NPF-18

Report No: 05000373/2017009; 05000374/2017009

Licensee: Exelon Generation Company, LLC

Facility: LaSalle County Station

Location: Marseilles, IL

Dates: April 24, 2017, through July 21, 2017

Inspectors: J. Benjamin, Senior Reactor Engineer, Team Lead, DRP
A. Dunlop, Senior Reactor Engineer, DRP
C. Phillips, Project Engineer, DRP
L. Rodriguez, Reactor Engineer, DRS

Approved by: K. O'Brien, Director
Division of Reactor Safety

Enclosure

SUMMARY

Inspection Report 05000373/2017009, 05000374/2017009; 4/24/2017–07/21/2017; LaSalle County Station, Units 1 and 2; Special Inspection Team Report and Exercise of Discretion

This report covers an 88-day period of onsite inspection and offsite review from April 24, 2017, through July 21, 2017. A four-member team comprised of two Senior Reactor Inspectors, one Project Engineer, and a Reactor Inspector conducted the inspection using Inspection Procedure 93812, "Special Inspection." The U.S. Nuclear Regulatory Commission's program for overseeing the safe operation of commercial nuclear power reactors is described in NUREG-1649, "Reactor Oversight Process," Revision 6.

NRC-Identified Findings and Violations

No findings were identified as a result of the inspection. However, a violation of Title 10 of the *Code of Federal Regulations*, Part 50, Appendix B, Criterion III, "Design Control," was identified by the Special Inspection Team. Specifically, the actuator settings for the Unit 1 and Unit 2 high pressure core spray (HPCS) injection valves (i.e., the 1E22-F004 valve and 2E22-F004 valve, respectively) were selected to ensure that the valves would have enough torque and thrust to operate under design basis conditions while staying below the maximum weak link limits. However, the licensee incorrectly identified the weak link of the valves as the valve stem, instead of the stem-to-wedge threaded and pinned connection, which had a more limiting structural capacity. As a result, the applied actuator loads exceeded the connections structural capacity and allowed: (1) the pressed-fit collar to move during valve operation; (2) the wedge pin to be in the load path; and (3) an increase in the loads applied to the threads of the connection.

As a result of the inadequate weak link analysis, the valve actuator settings were inadvertently selected so that the applied actuator loads exceeded the threaded and pinned connection's structural capability. Once the connection's structural capability was exceeded, degradation of the connection continued to occur during normal valve operation until the eventual failure of the connection (i.e., stem-to-disc separation). This failure mechanism caused the 2E22-F004 valve to fail in the closed position on February 11, 2017, while the plant was shutdown for a refueling outage, and resulted in the HPCS system being unable to perform its licensing basis safety function.

The team did not identify an associated performance deficiency for the inadequate weak link analysis. Specifically, the team determined that this issue was not within the licensee's ability to foresee and correct. This determination was partially based on the fact that it was a latent design issue that had not been previously identified within the industry. Therefore, this violation was determined not to meet the requirements of a finding.

The U.S. Nuclear Regulatory Commission determined the issue described above was a Severity Level III Violation based on Section 6.1(c)(2) of the Enforcement Policy. Specifically, the failure of the valves would have prevented the HPCS system from performing its safety function if called upon. However, because there was no associated performance deficiency, the U.S. Nuclear Regulatory Commission exercised enforcement discretion in accordance with Sections 3.10 of the Enforcement Policy and Section 3 of Part 1 of the Enforcement Manual.

REPORT DETAILS

4. OTHER ACTIVITIES

4OA3 Event Follow-up – Special Inspection (IP 93812)

Event Description

On February 11, 2017, the station identified that the Unit 2 high pressure core spray (HPCS) system injection valve, 2E22-F004, stem had separated from the wedge disc while attempting to fill and vent the system during a refueling outage. Prior to the fill and vent activity, the system had been taken out of service to perform leak rate testing and then drained to support maintenance. The 2E22-F004 valve leak rate test results were completed satisfactorily. System parameters observed during the leak rate test demonstrated that the injection valve had physically cycled open and closed which indicated that the valve had failed within a small number of strokes following the leak rate test, but prior to the system fill and vent evolution.

At the time of discovery, the HPCS system was still inoperable for the previous work window, so no immediate operability concerns existed. Subsequent licensee inspections of the valve internals identified that a stem-to-disc separation had occurred. Specifically, the valve failed in a manner consistent with that described in two separate 2013 Title 10 of the Code of Federal Regulations (CFR), Part 21 notifications: 2013-09-00, "Wedge Pin Failure in Anchor Darling Motor Operated Double Disc Gate Valve (See related 10 CFR Part 21 Report No. 2013-02-00," initiated by Flowserve (Reference: ML13064A012) and 2013-02-00, "Anti-Rotation Pin Failure in 10-inch Anchor Darling (Flowserve) Double Disc Gate Valve," initiated by Browns Ferry Unit 1 (Reference: ML13008A321). The valve internals were subsequently replaced and the system was restored to operable status. On April 12, 2017, the licensee submitted Licensee Event Report 50-374/2017-003-00, "High Pressure Core Spray System Inoperable due to Injection Valve Stem-Disc Separation" (Reference: ML17102B424) as a result of the failed valve.

After receiving the Licensee Event Report, the U.S. Nuclear Regulatory Commission (NRC) Region III staff evaluated the incident using the deterministic and conditional risk criteria specified in NRC Management Directive 8.3, "NRC Incident Investigation Program." The staff concluded that the incident met Management Directive 8.3, Criterion b, "Involved a major deficiency in design, construction, or operation having potential generic safety implications," Criterion d, "Led to the loss of a safety function or multiple safety failures in systems used to mitigate an actual event," Criterion e, "Involved possible adverse generic implications," and Criterion g, "Involved repetitive failures or events involving safety-related equipment or deficiencies in operations." Additionally, a Region III Senior Reactor Analyst used the LaSalle SPAR model for the evaluation. The delta core damage probability for the condition was estimated to be 2.5E-5. The dominant sequence involved a loss of main feed water, failure of HPCS and reactor core isolation cooling, and the failure to depressurize the reactor.

As a result of the Management Directive 8.3 evaluation, a special inspection was initiated in accordance with NRC Inspection Procedure 93812, "Special Inspection," and the Special Inspection Team (SIT) Charter dated April 21, 2017, (Reference: Attachment 2).

a. Inspection Scope

The SIT performed data gathering and fact-finding to address the following items from the inspection charter (Reference: Attachment 2). The team interviewed station personnel and performed physical walk downs of plant equipment. The team reviewed procedures, maintenance and test records, corrective action reports, operability evaluations, vendor records, the 2E22-F004 valve failure analysis report, and other related documents.

(1) Develop a sequence of events time line beginning from the time the Unit 2 high pressure core spray valve (2E22-F004) had been procured and installed in the plant until the recent stem-to-disc separation failure (Charter Item 1)

The inspectors interviewed station personnel and reviewed control room logs, corrective action documents, maintenance work orders and work requests, test records, and the failure analysis report as part of the inspection activity. The following timeline is an overview of the maintenance, testing, modification history, and other pertinent milestones associated with the 2E22-F004 valve. The intent of the timeline is to capture significant valve related activities.

- The 2E22-F004 valve, which failed around February 11, 2017, was installed during plant construction and was used during pre-operational testing in the early 1980s. The stem and wedge assembly and associated threaded connection had not been inspected, maintained, or modified, from original installation to failure.
- March 1987: Motor-Operated Valve and Test System testing was performed on the 2E22-F004 valve. A measured closing thrust value of 38,400 pounds force (lbf) was recorded. The target value was 50,294 lbf. Therefore, the torque switch setting was increased from 2.25 to 4.00 and the closed thrust value was determined to be 100,800 lbf. Work history documents indicated that this value was for a stem that needed to be lubricated (i.e., expected to be higher for a well lubricated stem).
- 1990: The valve vendor provided, and the station accepted, an analysis of the weak link for the 1/2E22-F004 valves. The analysis identified that the valve stem was the weak link during the valve closing stroke.
- January 1992: Valve Operational Test and Evaluation System (VOTES) testing could not declutch the valve in order to stroke it open. The closed torque switch setting was adjusted down from 4.00 to 3.50. The closed thrust of 196,627 lbf was measured with the 3.50 torque switch setting. The closed limit set for torque switch bypass was set to less than 2 percent of valve seating.
- April 1992: The torque switch bypass limit was adjusted to open at 5 to 10 percent valve seating.
- February 1995: The overall actuator gear ratio was changed from 48.45:1 to 92.12:1 by installing a 25 tooth motor pinion gear, a 47 tooth worm shaft gear, and a new worm actuator gear.

- March 1995: A modification was performed by drilling a hole through the reactor side valve disc to address a generic issue of pressure locking and thermal binding of the valve. The work order indicated that the discs were replaced due to cracking.
- October 1996: The licensee modified the control circuitry of the valve to defeat the auto close signal interlock.
- November/December 1998: The VOTES testing was performed and the measured closed thrust value was 231,636 lbf.
- February 2005: The VOTES testing was performed and all measured torque and thrust values met the criteria within the design setup window. The maximum closed thrust value of 218,333 lbf met the acceptance criteria of less than 268,000 lbf. The 4,265 ft-lbs maximum closed torque value met the acceptance criteria of less than 8,250 ft-lbs.
- 2011: A diagnostic torque and thrust trace was performed on the 2E22-F004 valve with no issues identified.
- January 4, 2013: Tennessee Valley Authority's Brown's Ferry Unit 1 initiated a 10 CFR Part 21 notification (Reference: ML13008A321) as a result of a defect discovered in the HPCI inboard containment isolation valve, which is a 10 inch Anchor Darling Double Disc Gate Valve (ADDDGV).
- February 25, 2013: Flowserve submits a 10 CFR Part 21 notification (Reference: ML13064A012) to identify that ADDDGV stems were potentially never completely torqued into the upper wedge prior to installation. This condition in conjunction with high operating torque and thrust on the stem-to-disc connection could lead to wedge pin failure and eventual stem-to-disc separation.
- April 13, 2013: The Boiling Water Reactor Owner's Group (BWROG) issued a Topical Report (Revision 0) to generically address the Flowserve and Tennessee Valley Authority 10 CFR Part 21 notifications and provided recommendations on prioritizing the susceptible valves. Specifically, the guidance recommended licensees evaluate each valve using valve stroke surveillance testing, observation of stem rotation, diagnostic testing, and valve seat leakage as bases for operability.
- 2015: A diagnostic torque and thrust trace was performed on the 2E22-F004 valve with no issues identified.
- April 28, 2016: The BWROG revised the Topical Report (Revision 1) to include operating experience provided by a separate utility. The separate utility disassembled 26 valves susceptible to the original 10 CFR Part 21 notifications and identified that 24 of the 26 were found with loose stem-to-wedge connections (i.e., no pre-torque), thus confirming the initial 10 CFR Part 21 issue.

- On February 8, 2017, the valve stem was cleaned and lubricated. A stem rotation check was then performed during a scheduled refueling outage. The stem rotation check was verified to be less than approximately 5–10 degrees between the open and closed strokes. This met the procedural acceptance criteria.
- On February 8, 2017, a local leak rate test was performed using water with a differential pressure of 1000 psi gauge plus or minus 50 psi across the valve. The leak rate test passed with minimal leakage. System parameters indicated that the valve stem and wedge/disc were cycling without issue.
- On February 11, 2017, the valve stem was identified to have separated from the wedge during a system fill and vent activity. Pictures of the degraded stem and embedded wedge thread fragments are shown below.



Figure 1 - As-Found Stem of Failed 2E22-F004 Valve

- In February 2017, a 100 ton lift was used at near rated capacity to remove the wedge and disc from the seat. The 2E22-F004 valve was repaired using a new stem with an integral collar as compared to the pressed-fit collar on the original stem that shifted up as shown above. The new stem was pre-torqued into the wedge to approximately 7000 ft-lbs of torque.
- On April 12, 2017, the licensee made a 10 CFR 50.73 notification to the NRC based upon an event or condition that could have prevented the fulfillment of a safety function and inoperability longer than the Technical Specification allowed outage time for the Unit 2 HPCS system.
- On April 21, 2017, the NRC chartered an SIT to review the circumstances surrounding the 2E22-F004 valve failure.
- On April 24, 2017, the NRC SIT conducted an entrance meeting for the inspection.
- From April 24, 2017–July 21, 2017, the SIT worked both onsite and offsite to complete the Charter. A significant portion of team's effort was spent on understanding the potential generic implications and determining if the Unit 1 HPCS injection valve which was of the same design and similar operating history as the Unit 2 HPCS valve should be relied upon to mitigate plant design basis accidents and transients.

- (2) Understand and assess the adequacy of the licensee's current explanation for the cause of the Unit 2 high pressure core spray valve stem-to-disc separation. As available, evaluate the scope, schedule, staffing and available results of the licensee's root cause investigation. (Charter Item 2)

On May 3, 2017, the team identified that the pressed-fit collar applied preload could be overcome with operational torque and thrust loads that could break the wedge pin and challenge the stem-to-wedge joint integrity. This issue was discovered during a review of the new valve design in which the vendor supplied information related to the previous pressed-fit collar.

The licensee entered this issue into its Corrective Action Program as Issue Report 040003319. The licensee concluded, at the time, that the design information provided with the new quality design package was not considered to be part of the current licensing basis for the previous 2E22-F004 valve and in-service 1E22-F004 valve threaded connections. Furthermore, the licensee concluded that the torque and resultant thrust forces under all conditions had been analyzed and found to be acceptable.

On May 30, 2017, the licensee completed the 2E22-F004 valve failure analysis. The analysis documented that the most likely failure mechanism was the pressed-fit collar was a limiting weak link for thrust in the closed direction. In accordance with this failure mechanism, the 2E22-F004 valve failure would have occurred even if the valve stem was pre-torqued into the valve wedge at the maximum allowable value. In summary, the licensee's 2E22-F004 valve failure analysis concluded that:

- **Initial Conditions.** The stem was manually threaded into the wedge with an initial preload that loaded the collar and put the stem threads into tension. The stem-to-wedge threaded connection was then pinned by drilling a hole through the wedge-stem-wedge. The initial installation torque and preload applied was very low and estimated to be less than 38,000 lbf based upon the pressed-fit collar capacity.

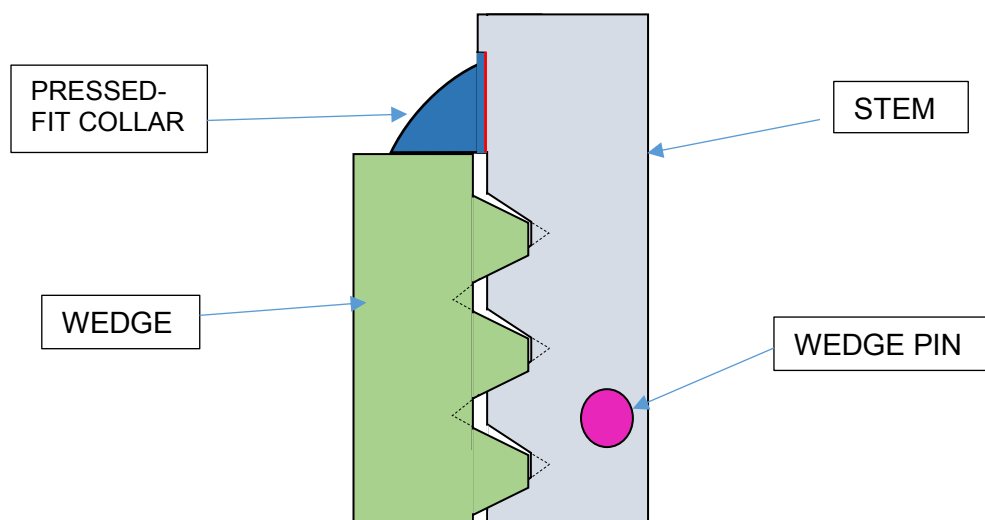

Figure 2 - Threaded Connection Diagram Initial Condition

- **Collar Slip/Loss of Preload.** The normally applied closed thrust loads of over 200,000 lbf exceeded the pressed-fit collar load capacity, causing it to slip. Once the collar slipped, preload was lost.

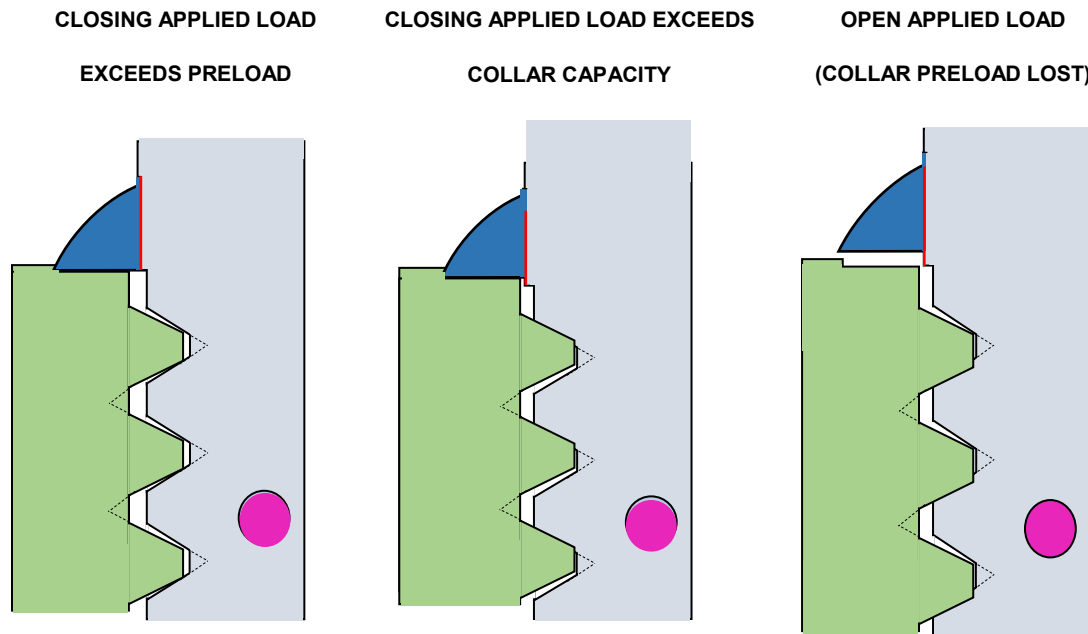

Figure 3 - Threaded Connection Degradation Diagram

- **Pin Shear.** After loss of preload, a portion of the axial loads were applied to the wedge pin, along with torsional loads, which exceeded the capability of the thread and collar friction. The subsequent applied torsional loads in the closing direction failed the wedge pin.
- **Joint Loosening/Rotation Movement.** Following failure of the wedge pin, the joint loosened allowing relative movement between the stem and wedge. The stem-to-stem nut threads are left handed threads, and the stem-to-wedge threads are right handed threads such that the stem, under torque, acted similarly to a turnbuckle. While only incremental, the motion led to unthreading and rethreading of the stem-to-wedge connection during subsequent valve opening and closing strokes. Even with minor unthreading in the open direction, small gaps formed between the stem collar and wedge. During a subsequent closing stroke with the gap, the closing axial loads were reacted upon primarily by the threads. However, the torsional component in the closing direction attempted to re-thread the stem into the wedge until the collar and thread resistances equaled the applied torque.
- **Thread Degradation and Wear.** Besides the failed pin allowing relative motion, the failed pin itself imparted damage to adjacent threads. The wedge threads began to wear and locally deform due to excessive and uneven thread loading in the loose connection. The wear was a combination of adhesive wear (i.e., galling) and aggressive abrasive wear (i.e., pseudo-machining under high load with damaged thread debris between the adjacent thread surfaces.) In this process, any residual broken pin fragments were pushed into the adjacent

threads with increased resistance. The stem threads material, 17-4 PH ferritic stainless steel, was significantly harder than the cast carbon steel wedge threads. This suggested that the stem threads acted similar to a machine tool when the wedge threads provided resistance. Evidence of this rotational loading and resistance was shown in the lab report, corresponding to the wiped stem threads at the pin location. Based upon the extent of the wiped threads, angular rotation up to about 270 degrees had occurred prior to the final joint thread failure.

- **Failure.** The lab investigation concluded that the wedge threads began to locally deform due to excessive and uneven thread loading in the loose connection. The threaded connection completely failed when the axial closing forces exceeded the strength of the remaining available thread cross-sections.
- **Post-Failure Troubleshooting.** After the stem-to-wedge threaded connection failed, the valve was cycled an additional number of times for troubleshooting. During these strokes, only the stem was moved open with some rotation and was re-inserted into the wedge thread hole until the collar and any residual interference in the threads resisted movement. In each case, the collar was pressed up upon the stem until it cocked to prevent further movement which caused the motor to trip.

(3) Review and assess the adequacy of the licensee's plan to address the extent of condition (Charter Item 3)

The team met with station management and discussed the planned corrective actions for all 10 CFR Part 21 valves following the 2E22-F0004 valve failure. The licensee became aware of the 10 CFR Part 21 issue in 2013, and prior to the 2E22-F004 failure had not implemented corrective actions to restore qualification for any of the 17 applicable safety-related and important to safety valves in service. However, correcting the 10 CFR Part 21 issue (i.e., lack of adequate preload in the stem-to-wedge assembly) would not have necessarily addressed the broader design issue involving the pressed-fit collar capacity described in Section 4OA3.2 of this report

On June 2, 2017, the licensee notified the NRC in a letter of their plans to correct all applicable valves during their next upcoming refueling outages (Reference: ML17156A799). On June 22, 2017, the licensee shutdown to test, inspect, and replace the 1E22-F004 valve with a new wedge and integral collar stem.

(4) Independently review applicable operating experience of similar issues within the industry to determine potential causes for the failure. Include in this review, the licensee receipt and disposition of the Tennessee Valley Authority and Flowserve Part 21 reports related to Anchor Darling Double Disc Gate Valves including the licensee incorporating vendor's recommendations (Charter Item 4)

The team reviewed operating experience from the Tennessee Valley Authority, the BWROG committee, and a recent ADDDGV issue at Columbia Generating Station to determine if the failures and operating experience were related. Additionally, the team reviewed a sampling of NRC generic communications to determine if the 2E22-F004 valve failure could have been attributed to any other known failure mechanism.

The operating experience reviewed supported the conclusion that the 2E22-F004 valve failed as a result of the design issue described in Section 4OA3.a.2 of this report. It was not known if the stem was adequately pre-torqued into the wedge during original assembly. However, the most likely failure mechanism was the inadequate capacity of the pressed-fit collar to withstand applied actuator thrusts and the resultant damage to the threaded connection during subsequent valve strokes. As a result, after an estimated 200 valve cycles, the threaded connection degraded to the point that it failed causing the stem-to-wedge separation.

(5) Understand and assess licensee's basis for current Technical Specification operability or general functionality for a sampling of valves that could be impacted by the cause or preliminary cause (Charter Item 5)

The team reviewed the licensee's basis for determining that all in-service 10 CFR Part 21 related valves were operable and functional. This review consisted of interviewing station and contracted support personnel. Additionally, the team reviewed condition reports, historic stem rotation checks, diagnostic testing data, and design information (e.g., weak link analyses). The team identified 16 safety-related and important to safety valves that were applicable to the 2013 10 CFR Part 21 notifications.

During this review, the team determined that the licensee had provided a reasonable basis for operability of all the 10 CFR Part 21 susceptible safety-related and important to safety valves in service with the exception of the 1E22-F004 valve. The majority of the 10 CFR Part 21 related valves were normally open valves with a design function to close once. The other 10 CFR Part 21 susceptible valves, that had a design function to cycle more than once, had significantly more margin available in structural calculations performed by the licensee and verified by the team. However, the team could not identify a significant discernable difference between the failed 2E22-F004 valve and the 1E22-F004 valve in service regarding the valves' design, susceptibility to the newly discovered design issue (as described in Section 4OA3.a.2), and operational history (i.e., number of cycles at high torque and thrust conditions).

Using the licensee's failure analysis for the 2E22-F004 valve, the team concluded that it was reasonable that the 1E22-F004 valve wedge pin most likely failed early in the valve's life, and that both the axial (thrust) and torsional (torque) loads caused increasing degradation of the stem-to-wedge threaded connection for approximately 30 years. Unlike the 2E22-F004 valve that had been in-service since original pre-operational testing, the 1E22-F004 valve stem and wedge assembly was replaced in 1987 after the stem was damaged due to a valve set up error. The inspectors reviewed the number of known and estimated valve cycles and the operational torque and thrust loads applied to the 1E22-F004 valve and determined that the number of valves strokes during pre-operational testing would constitute the only difference. Since the number of valve strokes and operational torque and thrust loads applied to 2E22-F004 valve was unknown during pre-operational testing, the team concluded that the 1E22-F004 valve could be expected to last longer than 2E22-F004 valve provided this difference alone. However, due to the unknown pre-operational testing differences, unknown slight design variations, material strength uncertainties, stem-to-wedge thread and stem to collar frictional uncertainty, and unpredictability within the failure mechanism itself, the team concluded that it was a matter of "when" and not "if" the 1E22-F004 valve would fail in the future if it had not already failed. Attempting to predict valve failure down to the cycle

or relatively small number of cycles left was not a reasonable basis to ensure that the 1E22-F004 valve would function as expected because of this uncertainty and associated lack of confidence.

Throughout the inspection, the team, NRC management, and the utility continued to engage in discussions regarding the operability of the 1E22-F004 valve. On June 24, 2017, while the plant was shutdown, the licensee repaired the 1E22-F004 valve by replacing the valve stem and wedge-disc assembly.

Prior to replacing the valve parts, the licensee performed as-found tests to evaluate the effectiveness of the stem rotation checks and diagnostic testing. The as-found stem rotation test identified an acceptable 2 degrees of stem rotation. Additionally, the licensee reviewed the as-found motor operated valve diagnostic traces and did not identify any abnormalities. The valve to stem wedge assembly was sent off-site for a failure analysis. At the failure analysis lab, the wedge pin was discovered to be broken and the stem torqued into the wedge such that it could not be unscrewed easily. The vendor cut the stem away from the wedge and identified a number of wedge and stem threads sheared; thereby, confirming the concerns that the valve was degrading.

- (6) Review an appropriate amount of condition reports related to stem disc separation issues at the site within the last 10 years. Review any associated trend and common cause evaluations (Charter Item 6)

The team reviewed a sampling of condition reports related to stem-to-disc separation events that occurred over the last 10 years to determine if there was an apparent trend and or common cause that could be attributed to the 2E22-F004 valve failure.

The 2E22-F004 valve failure most likely occurred due to a design issue as concluded by the licensee and evaluated by the team. Specifically, the pressed-fit collar had not been considered in the licensee's safety-related weak link analysis, which could lead to a loss of preload in the stem-to-wedge threaded connection. The team did not identify prior occurrences of valves failing at the station due to these issues.

- (7) Assess the licensee's use of the motor operated valve Condition Monitoring Program for the Unit 1 and Unit 2 high pressure core spray valves and a sampling of valves within the scope of the extent of condition. Include the Unit 1 and 2 reactor core isolation cooling discharge valves (Charter Item 7)

The team reviewed historic diagnostic testing and the licensee's evaluation of the data to determine if the licensee had a reasonable opportunity to identify the 2E22-F004 valve stem-to-wedge joint degradation prior to failure. Additionally, the team performed a detailed review of all of the 10 CFR Part 21 valve testing data to independently identify if any abnormalities had not been appropriately dispositioned by the licensee.

During the inspection, the licensee provided the team with evaluations that supported that the station had not missed any prior opportunities to identify degradation on the 2E22-F004 valve (i.e., the valve diagnostic testing previously performed on the failed valve did not identify a potential failure or degradation as identified in the 10 CFR Part 21 reports). The team conducted interviews with the licensee and their contractors to understand how the traces were reviewed and associated abnormalities were dispositioned.

The team reviewed the licensee's evaluation of the 2015 2E22-F004 valve diagnostics to determine if the stem-to-wedge degradation was able to be identified. Specifically, the team evaluated abnormalities in the diagnostic traces. The licensee's basis for the 2015 as-found and as-left thrust trace abnormalities was that the stem was a slightly less self-locking during the period of relaxation following a stem lubrication maintenance activity. In addition the licensee stated that since the closed seating thrust traces showed normal and consistent behavior, there was no corresponding evidence for the seating thrust traces that suggested that stem-to-disc connection was "re-threading" nor were there any other observed diagnostic trace abnormalities that would indicated a loose stem-to-disc connection. The team agreed that this was a reasonable conclusion. Specifically, the team agreed that the diagnostic traces performed by the licensee were not able to identify that degradation was occurring or the valve would eventually fail.

Additionally, the team determined that the stem rotation checks performed at the site were not a reliable indicator that stem-to-wedge degradation was occurring or would occur in the future. This determination was based upon the minimum rotation that the 2E22-F004 valve demonstrated just prior to failure. Additionally, the licensee's failure analysis supported that the failure could have occurred with less than 5 degrees of stem rotation.

The team concluded that the stem rotation checks and valve diagnostic testing were not reliable indicators to determine if stem-to-wedge joint degradation had occurred, nor did these tests demonstrate that the valve would perform its safety function in the future.

(8) Identify any potential generic safety issues. Include in this review a specific review of the Part 21 and any common industry position to address (Charter Item 8)

The team reviewed and discussed the BWROG Topical Report TP-17-1-112, Revision 0, 1, and 2, with station personnel including an Exelon BRWOG utility member to determine if the guidance in the document was adequate to address safety and ensure compliance with existing regulations.

The team identified a potential generic issue with the pressed-fit collar being a weak link that may not be well known within the industry. This issue was validated following the completion of the licensee's failure analysis and was identified to be a design issue generic to the industry. Subsequently, the Agency issued Information Notice 2017-03, "Anchor/Darling Double Disc Gate Valve Wedge Pin and Stem-Disc Separation Failures," to inform all licensees of operating experience regarding this failure mechanism (Reference: ML17153A053). Additionally, the valve manufacturing vendor, Flowserve, has updated the original 10 CFR Part 21 notification and issued 10 CFR Part 21 notification 2013-09-01, "Wedge Pin Failure in Anchor Darling Motor Operated Double Disc Gate Valve (Update)," (Reference: ML17194A825). The update includes a discussion of the potential to push up on the pressed-fit collar which would reduce or eliminate any existing preload in the wedge. Also, the updated 10 CFR Part 21 notification discusses the failure mechanism experienced at LaSalle as a result of the pressed-fit collar pushing up causing the wedge pin to become the weak link in the valve design.

b. Findings

No findings were identified as a result of the inspection. However, a violation of 10 CFR Part 50, Appendix B, Criterion III, "Design Control," was identified by the SIT. The violation was determined not to be a finding because no performance deficiency was identified. Specifically, the SIT determined that the failure to incorporate the pressed-fit collar as the weak link instead of the stem itself into the design calculation was not within the ability of the licensee to foresee and correct based upon the weak link analysis originating from the vendor in 1990 and station review and acceptance of that document as a quality design. Additionally, the team determined that the issue would have been unlikely to be identified during routine surveillances or routine quality assurance activities, since the design issue was an unrecognized latent and generic issue.

Anchor Darling Double Disc Gate Valve 1E22-F004 and 2E22-F004 Pressed-Fit Collar Related 10 CFR Part 50, Appendix B, Criterion III Violation

Description: In 1990, the licensee had reviewed and accepted the vendor's weak link analyses that provided the upper torque and thrust limits for all safety-related ADDDGV in service at the station. This analysis documented that the 1E22-F004 and 2E22-F004 valve stems were the weak link valve components in the closing direction (i.e., provided enough closing thrust, the valve stems would be the first component to become nonfunctional). Therefore, the closed thrust limit for the 1E22-F004 and 2E22-F004 valves was approximately 260,000 lbf. The licensee had set up the valves in a manner that would ensure that the valves would have enough torque and thrust to operate under design basis conditions while staying below the maximum weak link limits. Maintenance and test records showed that the licensee consistently verified that these two valves were setup and maintained within this design window. Typical as-found and as-left closed thrust limits ranged from approximately between 200,000—240,000 lbf.

As described in the licensee's failure analysis report and as discussed above, the licensee identified that the pressed-fit collar could relax its pre-load when operating the valve well within the established maximum closed thrust limitations. The licensee's failure analysis report estimated that approximately 130,000 lbf was necessary to shift the collar up and relax the pre-load. Therefore, the team concluded that the licensee's weak link analysis was inadequate based upon the 2E22-F004 valve failure and associated failure analysis which determined that the pressed-fit collar was a weaker component as compared to the valve stem.

The team did not identify an associated performance deficiency for the inadequate weak link analysis. This determination was based upon the weak link analysis originating from the vendor in 1990, licensee's review of that analysis, and latent design issue that had not been previously identified within the industry until recently identified by the licensee.

Additionally, the team did not identify a violation of 10 CFR Part 50, Appendix B, Criterion XVI, "Corrective Action". This determination was based, in part, that correcting the unknown stem collar pre-torque issue after receiving the 10 CFR Part 21 Flowserve notification would not necessarily have identified and corrected the non-conforming inadequate weak link design control issue.

Enforcement: Title10 CFR Part 50, Appendix B, Criterion III, “Design Control,” requires, in part that measures shall be established to assure that applicable regulatory requirements and the design basis, as defined in 50.2, and as specified in the license application, for those structures, systems, and components to which this appendix apply are correctly translated into specifications, drawings, procedures, and instructions.

Contrary to the above, since original plant construction, the licensee failed to ensure that applicable design basis maximum closed thrust and torque values for the safety-related Unit 1 and Unit 2 HPCS injection valves (1E22-F004, 2E22-F004) were correctly translated into specifications. Specifically, it was identified that the stem-to-wedge pre-torque credited within the design could relax by applying closed direction torque and thrust well within the specified design limit because that limit was based upon the wrong weak link component. The loss of the stem-to-wedge pre-torque could subsequently break the wedge pin and result in stem-to-wedge thread degradation ultimately leading to valve failure.

The NRC determined that issue was a Severity Level III Violation based upon Section 6.1(c)(2) of the Enforcement Policy. Specifically, a system that is part of the primary success path and which functions or actuates to mitigate a design base accident or transient that either assumes the failure of or presents a challenge to the integrity of the fission product barrier not being able to perform its licensing basis safety function because it is not fully qualified.

The NRC exercised enforcement discretion in accordance with Sections 3.10 of the Enforcement Policy and Section 3 of Part 1 of the Enforcement Manual. Enforcement Policy Section 3.10 states that the NRC may exercise discretion for violations of NRC requirements by reactor licensees for which there are no associated performance deficiencies.

This violation was entered into the Corrective Action Program as Issue Report 3972901 and has been corrected by replacing the 1E22-F004 and 2E22-F004 valve stems with integral collars.

4OA6 Management Meetings

.1 Exit Meeting Summary

On July 21, 2017, the inspectors presented the inspection results to Mr. W. Trafton and other members of the licensee staff. The licensee acknowledged the issues presented.

.2 Interim Exit Meetings

An interim exit was conducted on June 9, 2017, the inspectors presented the inspection results to Mr. W. Trafton and other members of the licensee staff.

ATTACHMENT 1: SUPPLEMENTAL INFORMATION

ATTACHMENT 2: SIT Charter

SUPPLEMENTAL INFORMATION

KEY POINTS OF CONTACT

Licensee

W. Trafton, Site Vice President
H. Vinyard, Plant Manager
N. Plumey, Sr. Manager Plant Engineering
G. Ford, Regulatory Assurance Manager
D. Murray, Pr. Regulatory Engineer
D. Gullott, Corporate Licensing Manager
G. Kaegi, Corporate Licensing Director
V. Shah, Engineering Deputy Director
S. Tanton, Engineering Design Manager
M. Chouinard, Engineering Manager
J. Stovall, Operations Director
M. Venaas, Organizational Effectiveness Manager
T. Basso, Corporate Engineering Director
J. Bashor, Corporate Engineering Director
M. DiRado, Corporate Engineering Senior Manager

U.S. Nuclear Regulatory Commission

K. O'Brien, Director, Division of Reactor Safety, Region III
M. Jeffers, Chief, Engineering Branch 2, Division of Reactor Safety, Region III

LIST OF ACRONYMS USED

ADDDGV	Anchor Darling Double Disc Gate Valve
BWROG	Boiling Water Reactor Owner's Group
CFR	<i>Code of Federal Regulations</i>
HPCS	High Pressure Core Spray
lbf	Pounds Force
NRC	U.S. Nuclear Regulatory Commission
PSI	Pounds Per Square Inch
SIT	Special Inspection Team
VOTES	Valve Operating Test and Evaluation System

LIST OF DOCUMENTS REVIEWED

The following is a partial list of documents reviewed during the inspection. Inclusion on this list does not imply that the NRC inspector reviewed the documents in their entirety, but rather that selected sections or portions of the documents were evaluated as part of the overall inspection effort. Inclusion of a document on this list does not imply NRC acceptance of the document or any part of it, unless this is stated in the body of the inspection report.

Calculations:

- LAS-1E22-F004; MidaCalc Results for 1E22-F004; March 19, 2015
- LAS-1E22-F012; MidaCalc Results for 1E22-F004; June 15, 2016
- LAS-1E22-F015; MidaCalc Results for 1E22-F015; June 10, 2016
- LAS-1E51-F008; MidaCalc Results for 1E51-F008; December 9, 2015
- LAS-1E51-F013; MidaCalc Results for 1E51-F013; June 10, 2016
- LAS-1E51-F063; MidaCalc Results for 1E51-F063; October 29, 2013
- LAS-2E22-F004; MidaCalc Results for 2E22-F004; March 2, 2017
- LAS-2E22-F012; MidaCalc Results for 2E22-F012; August 25, 2015
- LAS-2E22-F015; MidaCalc Results for 2E22-F015; August 25, 2015
- LAS-2E51-F008; MidaCalc Results for 2E51-F008; February 10, 2017
- LAS-2E51-F063; MidaCalc Results for 2E51-F063; October 31, 2014
- CE-LS-003; Calculation for Stem Allowable Load Limits for Motor Operated Valves; March 1, 2017
- CE-LS-006; MOV Weak Link Analysis for Gate Valves, Revision 0
- R92.051; Design, Seismic and Maximum Thrust Analysis 10-Inch Class 900 Carbon Steel Double Disc Gate Valve with SB-2 Limitorque Operator; March 3, 1999
- L-000333; Seismic Thrust Limit of LaSalle Motor Operated Valves Listed Below (A/D, 12", DD Gate with Operator); March 3, 2017
- A/DV or Flowserve Calculation ET145-7, E713A-2; Design, Seismic and Maximum Thrust Analysis for 10 Inch Class 900 Carbon Steel DDGV with SB-2 Limitorque Actuator Common Wealth Edison Co. LaSalle Station; March 3, 1999

Drawings:

- VPF 3173-269, "12"-900# Motor Control Valve Outline," Revision 5
- 94-13499; Double Disc Gate Valve Carbon Steel Outside Screw and Yoke with SMB-4 Limitorque Valve Control, ANSI Series 900 Size:12 Class: C900; Revision 5
- PI&D M-57; Unit 1 Feedwater and Zinc; Rev B
- PI&D M-95; Unit 1 High Pressure Core Spray; Revision AQ
- PI&D M-101; Unit 1 Reactor Core Isolation Coolant; Revision BH
- PI&D M-97; Unit 1 Reactor Water Clean Up; Revision AO
- PI&D M-118; Unit 2 Feedwater and Zinc; Revision O
- PI&D M-141; Unit 2 High Pressure Core Spray; Revision AS
- PI&D M-147; Unit 2 Reactor Core Isolation Coolant; Revision BL
- PI&R M-143; Unit 2 Reactor Water Clean Up; Revision AR
- Horsenotes Drawing FW-1; Feedwater System; Revision 2
- Horsenotes Drawing HP-1; High Pressure Core Spray System; Revision 2
- Horsenotes Figure 061-01; High Pressure Core Spray System; September 10, 2004
- Horsenotes Drawing RI-1; RCIC System; Revision 5
- Horsenotes Drawing RT-1; Reactor Water Cleanup System; Revision 3

Engineering Changes:

- EC 618171; 2E22-F004 Valve Modifications; Revision 0, 1

Evaluations:

- Operability Evaluation 17-002 Revision 0, "Anchor Darling Double Disc Gate Valve Part 21 Issue"
- Operability Evaluation 17-002 Revision 1, "Anchor Darling Double Disc Gate Valve Part 21 Issue"
- Operability Evaluation 17-002 Revision 2, "Anchor Darling Double Disc Gate Valve Part 21 Issue"
- Operability Evaluation 17-002 Revision 3, "Anchor Darling Double Disc Gate Valve Part 21 Issue"

Issue Reports:

- IR 01484815, Flowserve 10CFR21, Valve Wedge Pin Failure – Anchor Darling
- IR 3995629; NRC ID SRI Question on 2E22-F004
- IR 3972901; 2E22-F004 Valve Stem Appears to be Stem/Disc Separated
- IR 3972910; Valve Stem Appears to Have Separated from the Disc
- IR 3973628; Need to Revise Package to Weld on Plates
- IR 3975531; 2E22-F015 Need Work Order to Diagnostic Test in L2R16
- IR 3995629; NRC ID - SRI Question Regarding 2E22-F004
- IR 3997971; NRC SRI Question, Operability Determination 10 CFR Part 21
- IR 4000548; Closure Notes For 2E22-F004 Has Slightly Different Wording
- IR 4002381; Non-Conforming Condition Associated With Anchor-Darling DDGV
- IR 4002465; NRC Identified a Potential Enhancement Opportunity 2E22-F004
- IR 4003111; NRC ID: Correction to Revision 2 of TP17-1-112
- IR 4003319; NRC Question on Weak Link Analysis Calculation for 1E22-F004
- IR 4009694; NRC Question on 1E22-F004 2012 Diagnostic Assessment Input
- IR 4011102; Past Torque Switch Settings for Anchor Darling Gate Valve
- IR 4016956; NRC ID: Questions on Revision 2 of OE 17-002

Letters:

- From Kalsi Engineering to Mr. Vikram R Shah, "Assessment of MOV 2E22-F004 Diagnostic" Test Data LaSalle County Nuclear Station, Unit 2"; April 29, 2017
- From Kalsi Engineering to Mr. Shah, "Assessment of 2012 Diagnostic Test Data Anomaly for 1E22-F004"; May 5, 2017
- From Kalsi Engineering to Mr. Shah, "Diagnostic Test Data Review Criteria"; May 15, 2017
- From Exelon Generation to U.S. Nuclear Regulatory Commission, "Commitments for Resolution of Anchor Darling Double Disc Gate Valve Part 21 Issues"; June 2, 2017
- From Kalsi Engineering to Mr. Shah, "Operability Evaluation for MOVs 1E22-F012, 2E22-F012, 1E22-F004, and 1E51-F013 at LaSalle County Nuclear Station"; May 20, 2017
- From Kalsi Engineering to Mr. Shah, "Diagnostic Test Data Review Criteria"; May 15, 2017
- From Flowserve to Exelon LaSalle Operation Station, "Size 12 Class 900 DD Gate Valve Maximum Thrust Analysis"; April 27, 2017

Miscellaneous

- Maintenance Update 92-01, Section 7, "Use of Stall Torque Calculations"
- Maintenance Update 92-02, Section 7, "Significance of Motor Brakes on Actuator Motors"
- Technical Update 93-03, "Reliance 3-Phase Limatorque Corporation Actuator Motors (Starting Torque at Elevated Temperature) Reference Potential 10CFR21 Condition Dated May 13, 1993"
- Technical Update 98-01 and Supplement 1, "Actuator Output Torque Calculation Reference SMB/SB/SBD Actuators / 3 Phase Motors"
- Module/LP ID: 077; Initial and Continuing Operator Training Feedwater System Training; Revision 15
- Module/LP ID: 061; Initial and Continuing Operator Training – High Pressure Core Spray System; Rev 9
- Module/LP ID: 032; Initial and Continuing Operator Training – Reactor Core Isolation Cooling System; Revision 9
- Module/LP ID: 027; Initial and Continuing Operator Training – Reactor Water Cleanup; Revision 9
- Flowserve Anchor Darling Double-Disc Gate Valve Installation Operation and Maintenance Manual
- Darling Valve and Manufacturing Company; Instruction Manual for Motor Operated Gate Valves; March 22, 1980
- Flowserve Corporation Maintenance Manual for Anchor/Darling Double-Disc Gate Valves 2-1/2" and Over 1E22-F004 Stem Subassembly Parts Classification Record PD # 87-214 from Nonsafety-Related to Safety-Related Upgrade; 8/8/1987 21A1740; Valve Data Specification 900A; Revision 6

MOV Traces:

- 1E22-F004 TSS and Thrust Information; Trend Data as of May 19, 2017
- 1E51-F013 TSS and Thrust Information; Trend Data as of May 19, 2017
- 2E22-F004 TSS and Thrust Information; Trend Data as of May 19, 2017
- 2E22-F012 TSS and Thrust Information; Trend Data as of May 19, 2017
- 1E22-F012 TSS and Thrust Information; Trend Data as of May 19, 2017
- 1E22-F012 TSS and Thrust Information; Trend Data as of May 19, 2017

Operating Experience:

- Flowserve Part 21 Report; "Wedge Pin Failure of an Anchor/Darling Double-Disc Gate Valve at Browns Ferry"; February 23, 2017
- TVA Part 21 Report; "Anti-Rotation Pin Failure in Anchor Darling (Flowserve) Double Disc Gate Valve; January 4, 2013
- TP17-1-112; "Recommendations to Resolve Flowserve 10 CFR Part 21 Notification Affecting Anchor Darling Double Disc Gate Valve Wedge Pin Failures"; Revision 0
- TP17-1-112; "Recommendations to Resolve Flowserve 10 CFR Part 21 Notification Affecting Anchor Darling Double Disc Gate Valve Wedge Pin Failures"; Revision 1
- TP17-1-112; "Recommendations to Resolve Flowserve 10 CFR Part 21 Notification Affecting Anchor Darling Double Disc Gate Valve Wedge Pin Failures"; Revision 2

Procedures:

- CC-AA-309-1012, "10 CFR Part 21 Technical Evaluations," Revision 3
- PI-AA-120, "Issues Identification and Screening Process"; Revision 7

- ER-AA-302, "Motor-Operated Valve Program Engineering Procedure"; Revision 6
- LS-AA-115, "Operating Experience Program"; Revision 17
- LOP-RI-02; Operation of the Reactor Core Isolation Coolant System for Level Control; Revision 32
- LOP-RI-09; Operation of the Reactor Core Isolation Coolant System for Pressure Control; Revision 11
- MA-AA-723-300; Diagnostic Testing of Motor Operated Valves; Revision 011
- MA-AA-723-300-1005; Review and Evaluation of Motor Operated Valve Test Data; Revision 002
- Standing Order S17-05; Anchor Darling Valve Cycling Compensatory Measures; Revision 0

Reports:

- BWROF-TP-13-006, Recommendations to Resolve Flowserve 10 CFR Part 21 Notification Affecting Anchor Darling Double Disc Gate Valve Wedge Pin Failures; Revision 0
- BWROF-TP-13-006, Recommendations to Resolve Flowserve 10 CFR Part 21 Notification Affecting Anchor Darling Double Disc Gate Valve Wedge Pin Failures; Revision 1
- BWROF-TP-13-006, Recommendations to Resolve Flowserve 10 CFR Part 21 Notification Affecting Anchor Darling Double Disc Gate Valve Wedge Pin Failures; Revision 2
- MPR 2-E22-F004 Failure Analysis Report; May 30, 2017

White Papers:

- Licensee's paper estimating the number of historic 1E22-F004 and 2E22-F004 valve cycles

Work Orders:

- WO 00703532; 2005 1E22-F004 MOV Diagnostic Test
- WO 01318009; 2011 1E22-F004 MOV Diagnostic Test
- WO 00465707; 2003 1E51-F013 MOV Diagnostic Test
- WO 01142189; 2009 1E51-F013 MOV Diagnostic Test
- WO 01664607; 2E22-F004 2015 Visual Verification of Minimum Stem Rotation for 2E22-F004
- WO 01615737, Borescope MTR, EQ Inspect & Votes 2E22-F004 in L2R15
- WO 01814252; Change Valve Stem Lubricant and Visual Inspection
- WO 00405631; 2005 2E22-F004 MOV Diagnostic Test
- WO 01235187; 2011 2E22-F004 MOV Diagnostic Test
- WO 01615737; 2015 2E22-F004 MOV Diagnostic Test
- WO 00703532; 2006 1E22-F004 MOV Diagnostic Test
- WO 01712040; 2016 1E22-F004 MOV Diagnostic Test
- WO 01318009; 2012 1E22-F004 MOV Diagnostic Test
- WO 00465707; 2004 1E51-F013 MOV Diagnostic Test
- WO 01142189; 2010 1E51-F013 MOV Diagnostic Test
- WO 01615737; 2015 2E22-F004 MOV Diagnostic Test
- WO 01618338; 2017 2E51-F008 MOV Diagnostic Test
- WO 01628679; 2015 2E22-F015 MOV Diagnostic Test
- WO 01716165; 2015 2E51-F063 MOV Diagnostic Test
- WO 01716166; 2015 2E22-F012 MOV Diagnostic Test
- WO 01727565; 2016 1G33-F001 MOV Diagnostic Test
- WO 01727598; 2016 1E22-F015 MOV Diagnostic Test
- WO 01727601; 2016 1E22-F012 MOV Diagnostic Test
- WO 01727616; 2016 1E51-F063 MOV Diagnostic Test
- WO 01727620; 2016 1E51-F013 MOV Diagnostic Test

- WO 01727624; 2016 1E51-F008 MOV Diagnostic Test
- WO 01768449; 2016 1G33-F004 MOV Diagnostic Test
- WO 01813294; 2017 2G33-F001 MOV Diagnostic Test
- WO 01813291; 2017 2G33-F004 MOV Diagnostic Test
- WO 01235187; 2011 2E22-F004 MOV Diagnostic Test
- WO 04600131; 2E22-F004 Valve Internal Repair
- WO 01807977; 2E22-F004 Water Leak Test
- WO 01727602; Perform Stem Lube and Minimal Stem Rotation Check 1E22-F004
- WO 01664600; Visual Verification of Minimal Stem Rotation for 1E22-F004
- WR L63334; Test Valve Using MOVATS Perform Necessary Adjustments and/or Repairs
- WR L67197; Perform MOVATS Testing on Valve 1E22-F004
- WR 930044315; To Resolve GL89-10 Thrust Concerns Change Actuator Gear Ratio;
- WR 93045691; Drill Hole in Reactor Side Disc to Prevent Valve from Becoming Hydrolocked
- ER-AA-302-1004 LAS-2E22-F004; MOV Post-Test Engineering Review Trend Evaluation Summary Report; August 25, 2015



UNITED STATES
NUCLEAR REGULATORY COMMISSION
LISLE, IL 60532-4352

April 21, 2017

MEMORANDUM TO: Jamie Benjamin, Senior Reactor Inspector
Engineering Branch 2, Region III

FROM: Kenneth O'Brien, Director /RA/
Division of Reactor Safety

SUBJECT: SPECIAL INSPECTION CHARTER FOR LASALLE COUNTY
STATION HIGH PRESSURE CORE SPRAY INJECTION VALVE
FAILURE

On February 11, 2017, while in Mode 5 during Refueling Outage L2R16, the licensee was attempting to fill and vent the high-pressure core spray (HPCS) system. After testing, it became apparent that the HPCS injection valve (2E22 F004) failed to open. At the time of discovery, the HPCS system was inoperable due to a previous work window, so no immediate operability concerns existed. Subsequent licensee inspections of the valve internals identified that a stem to disc separation had occurred. Specifically, the valve failed in a manner consistent with that described in a 2013 Part 21 Notification (EN 48797). The valve internals were subsequently replaced and the system was restored to an operable status.

Prior to its failure, the HPCS injection valve was stroked open and closed on February 8, 2017, after the completion of its local leak-rate test, with verification of air flow through the downstream vent valves while draining—confirming the HPCS injection valve was open at that time. Based on that indication, the licensee believed that the valve remained operable up until the point it failed sometime between the local leak-rate test on February 8, and the time of discovery during the fill and vent on February 11. However, operation of the HPCS system is expected to have the injection valve cycle multiple times during the duration of its design basis mission time. The as-found condition of the valve internals, as well as the fact that the valve failed after one stroke while not under accident conditions, brought into question the past-operability of the valve.

The sequence of events and the cause of the problem are being investigated by the licensee. Based on the deterministic criteria provided in Management Directive (MD) 8.3, "NRC Incident Investigation Program," the incident met MD 8.3 Criterion b, "Involved a major deficiency in design, construction, or operation having potential generic safety implications," Criterion d, "Led to the loss of a safety function or multiple safety failures in systems used to mitigate an actual event," Criterion e, "Involved possible adverse generic implications," and Criterion g, "Involved repetitive failures or events involving safety-related equipment or deficiencies in operations."

CONTACT: Mark Jeffers, EB2 Branch Chief
630-829-9798

Additionally, a Region III Senior Reactor Analyst using the LaSalle SPAR model, performed a risk assessment of the extent of condition. The following assumptions were used in the risk assessment: (1) the injection valve would not open; (2) the basic event for the HPCS injection valve failure to open was set to "True;" (3) the exposure period was 1 year; and (4) the system was not recoverable. No other adjustments to the SPAR model were made. The delta core damage probability for the condition was estimated to be $2.5E-5$. The dominant sequence was a loss of main feed water, failure of HPCS and Reactor Core Isolation Cooling systems, and the failure to depressurize the reactor. Loss of offsite power sequences also contribute to the risk. Incremental Conditional Core Damage Probability value was approximately $1E-6$ to $1E-5$ assuming the strainers for Residual Heat Removal (RHR) and Low Pressure Core Spray systems were plugged in response to only loss of coolant accident (LOCA) events. The Incremental Conditional Core Damage Probability is approximately $6.4E-4$ if the strainers for RHR and Low Pressure Core Spray systems are plugged with debris in response to both LOCA events and non-LOCA events, which is worst case bounding condition.

Accordingly, based on the deterministic and risk criteria in MD 8.3, and as provided in Regional Procedure 8.31, "Special Inspections at Licensed Facility," a special inspection team will commence an inspection on April 24, 2017. The special inspection team will be led by you and will include Andy Dunlop, Lionel Rodriguez, and Chuck Phillips from the Region III office. The special inspection will determine the sequence of events and will evaluate the facts, circumstances, and the licensee's actions surrounding valve failure. The specific charter for the team is enclosed.

Enclosure:
LaSalle Special Inspection Charter

J. Benjamin

-3-

Memo to Jamie Benjamin from Kenneth G. O'Brien dated April 21, 2017

SUBJECT: SPECIAL INSPECTION CHARTER FOR LASALLE COUNTY STATION HIGH
PRESSURE CORE SPRAY INJECTION VALVE FAILURE

DISTRIBUTION:

Cynthia Pederson
Darrell Roberts
Allan Barker
Harral Logaras
Patrick Louden
Julio Lara
Kenneth O'Brien
Mohammed Shuaibi
Andrew Dunlop
Charles Phillips
Lionel Rodriguez
Michael Johnson
Michael Scott
David Pelton
Raymond Lorson
Jimi Yerokun
Joel Munday
Mark Franke
Tony Gody
Mark Miller
Troy Pruett
Ryan Lantz
Anton Vogel
Jeff Clark
Robert Ruiz

NRR_Reactive_InspectionResource@nrc.gov

ADAMS Accession Number ML17111A801

OFFICE	RIII	RIII	RIII	RIII
NAME	MJeffers:cl	KStoedter	PLouden	KO'Brien
DATE	04/20/17	04/20/17	04/20/17	04/21/17

OFFICIAL RECORD COPY

LASALLE SPECIAL INSPECTION CHARTER

This special inspection team is chartered to assess the circumstances surrounding the high-pressure core spray injection valve failure identified during the refueling outage on February 11, 2017. The decision to charter this special inspection team is due to the potential generic industry implications which need to be understood by the U.S. Nuclear Regulatory Commission and may lead to changes regarding how best to address valves subject to a 2013 Part 21 Notification by Flowserve. The Special Inspection will be conducted in accordance with Inspection Procedure 93812, "Special Inspection," and will include, but not be limited to, the items listed below. This Charter may be revised based on the inspection findings and the results will be documented in U.S. Nuclear Regulatory Commission Inspection Report 05000373/2017009; 05000374/2017009.

1. Develop a sequence of events time line beginning from the time the Unit 2 high pressure core spray valve was procured and installed in the plant until the recent stem to disc separation failure.
2. Understand and assess the adequacy of the licensee's current explanation for the cause of the Unit 2 high pressure core spray valve stem to disc separation. As available, evaluate the scope, schedule, staffing, and results of the licensee's root cause investigation.
3. Review and assess the adequacy of the licensee's plan to address the extent of condition.
4. Independently review a sample of applicable operating experience of similar issues within the industry to determine potential causes for the failure. Include in this review, the licensee's receipt and disposition of the Tennessee Valley Authority and Flowserve Part 21 reports related to Anchor/Darling double disc gate valves including the licensee's incorporating vendor's recommendations.
5. Understand and assess licensee's basis for current Technical Specification operability or the general functionality for a sampling of valves that could be impacted by the cause or preliminary cause.
6. Review the population and review an appropriate amount of condition reports related to stem disc separation issues at the site within the last 10 years. Review any associated trend and common cause evaluations.
7. Assess the licensee's use of the motor operated valve condition monitoring program for the Unit 1 and Unit 2 high pressure core spray valves and a sampling of valves within the scope of the extent of condition. Include Unit 1 and 2 reactor core isolation cooling discharge valves.
8. Identify any potential generic safety issues. Include in this effort a specific review of the associated Part 21 reports and any common industry position to address. Additionally, identify if this issue is site specific, a result of a corporate initiative, or an industry wide issue.
9. Identify lessons learned from the Special Inspection and, as appropriate, prepare a feedback form on recommendations for improving reactor oversight process baseline inspection procedures.

Enclosure

Charter Approval

 /RA/ 04/20/17 M. Jeffers, Chief, Engineering Branch 2, DRS

/RA Raymond Ng Acting for/ 04/20/17 K. Stoedter, Chief, Branch 1, DRP

/RA Julio Lara Acting for/ 04/20/17 P. Loudon, Director, DRP

 /RA/ 04/21/17 K. O'Brien, Director, DRS