

3.3 Plant Water Use

Plant water use considers both plant water consumption and plant water treatment. Figures 3.3-1 and 3.3-2 provide diagrams of the STP 3 & 4 normal operation flows and plant makeup water flows, respectively. The consumption of plant water will closely resemble practices currently followed by STP 1 & 2, which are described in section 10.5S.2. These practices reflect standard practices followed by all nuclear plants, and comply with all state and federal regulatory and permit requirements.

The STP site has two sources of water:

- Colorado River supplies makeup to the Main Cooling Reservoir (MCR) that serves as the primary heat sink for plant condenser and turbine building service water cooling. It will also serve as a backup source of makeup for the Ultimate Heat Sink (UHS).
- Onsite wells supply water needs for the power block operational uses, fire protections system, potable and sanitary waters system (PSW), and the UHS. As detailed further in Section 2.3.1.2.4.3, STPNOC intends to install at least one additional site groundwater well with a design capacity of 500 gpm. Any additional wells would be properly permitted under applicable Coastal Plains Groundwater Conservation District (CPCGD) and TCEQ requirements, and would not involve a request for an increase in the existing groundwater operating permit limit.

3.3.1 Water Consumption

Well water is pretreated and demineralized for use in the power block as makeup to the condenser hotwell to replenish losses as well as to provide makeup water to the other plant demineralized water users. A portion of the well water is supplied as potable water for the plant's potable water users.

The MCR loses water from evaporation and seepage and gains water through makeup from the Colorado River and rainfall. Surface water consumptive use due to STP 3 & 4 heat loads during normal operating conditions is estimated to be approximately 23,190 gpm for full heat load and 21,600 gpm on a long-term average basis for 93% heat load. Water uses projected for the operation of STP Units 3 & 4 are derived from system design data as well as from operational water use data for specific systems for which such data is available (Reference 3.3-4). Conservative water use projections for simultaneous operation of both STP Units 3 and 4 are summarized in Table 3.3-1, and include a total estimated normalized groundwater demand of approximately 975 gpm (approximately 1574 acre-feet/year), and approximately 3434 gpm for maximum short-term steady-state conditions. During normal operation, approximately 391 gpm of plant effluent water (UHS basin blowdown, filter backwash, etc.) is discharged to the MCR as surface water. Table 3.3-1 identifies the normal and maximum water and effluent streams for STP 3 & 4, and Figure 3.3-1 provides a diagram to illustrate the normal operation flows.

The UHS for STP 3 & 4 will consist of mechanical draft cooling towers that receive makeup water from the well water system. The groundwater supply wells for STP 3 & 4 are not safety-related sources of water, because the UHS has a 30-day supply of

water, which is sufficient for plant shutdown without a supplementary water source. During normal operation, the UHS will be evaporating an expected 566 gpm (2 units) of water, causing an increase in UHS basin water total dissolved solids. Water from the UHS is blown down to the MCR to keep the total dissolved solids at acceptable levels, with the discharged water to be made up from the onsite well water system.

Table 3.3-1 provides the normal and maximum flow rates for STP 3 & 4 systems that use surface water or groundwater. Table 3.3-1 envelops the water consumption during periods of minimum water availability and average plant operation by month for STP 3 & 4 only.

STP 1 & 2 water usage can be seen in Reference 3.3-2. The cumulative impacts can be seen in section 10.5S.2. Figures 3.3-1 and 3.3-2 show the plant makeup flows including potable water, demineralized water, and the UHS. The figures also show plant waste streams including treated radwaste effluents, treated sanitary wastes and low-volume wastes, which consist of reverse osmosis reject, filter backwash waste, oil/water separator effluent, and miscellaneous drains. The normal values listed in Table 3.3-1 are the expected flow values during normal plant operation at full load and the maximum values are those expected during outages and abnormal conditions such as emergency, hot standby, hot standby with loss of AC or shutdown. The rate of surface water consumption shown in Table 3.3-1 is not directly related to the rates of withdrawal and discharge to the Colorado River. Withdrawal from the Colorado River depends on the river flow rate, river water quality and MCR level. Fluctuations in the makeup water availability are accommodated by the maintaining the MCR water level within an acceptable range.

The flows from the miscellaneous demineralized water drains and low-volume wastewater are released to a wastewater retention basin(s) where it will be sampled prior to discharge. The water will be sent to a discharge line and discharged to the MCR. The treated liquid radwaste effluent and sanitary wastewater will be sent to the discharge line and released to the MCR.

3.3.2 Water Treatment

The water treatment systems for STP 3 & 4 will be similar to those in use at the existing STP 1 & 2. Treatment systems will be required for systems supplied by groundwater, including:

- Condensate water makeup
- UHS basin water makeup
- Potable water
- Radwaste
- Fire protection systems

The circulating water system at STP 3 & 4 draws water from the MCR, which receives its makeup water from the Colorado River. Biocides and anti-scalant will be injected at

the circulating water intake structure to control biofouling and scaling in the circulating water system and associated piping.

Well water is first sent to a filtration system, then chemical conditioned (including disinfection), and transported to a filtered water tank. The filters will be periodically backwashed to remove accumulated solids. The filtered water is distributed to the Fire Protection System and the Makeup Water Preparation (MWP) System.

The PSW System distributes drinking water throughout the power plant. The potable water will be distributed at low flow rates during normal plant operation. At peak times, such as refueling, the PSW will provide maximum flows of approximately 50 gpm per unit. The PSW is sized to provide instantaneous flows of up to 200 gpm per unit for short time periods. Potable water peak demands are expected during plant outages due to high plant population.

Demineralized water for plant uses is produced by the MWP System (See Figure 3.3-2). Water is treated by filtration, reverse osmosis, and mixed bed demineralization processes. The MWP System is designed to reduce suspended and dissolved solids, organics, and colloidal particles present in the well water. Before the reverse osmosis system, a water softener system or a combination of sulfuric acid and sodium hexametaphosphate will be added to control fouling. Sodium hydroxide is added to the first pass permeate of the reverse osmosis system to adjust the pH to improve dissolved solids rejection in the second pass. Chemical addition quantities are proportional to water quality and will be added as needed to provide proper water chemistry. The demineralizers will provide final polishing after the reverse osmosis treatment. The demineralizer resins will be regenerated offsite; therefore, no demineralizer regeneration waste will be generated on site. The waste from the filters is sent to a low-volume waste sump and eventually discharged to the MCR. The MWP System will have peak demands mainly during startup and refueling outages. The MWP System provides makeup water to the Makeup Water Condensate (MUWC) System and Makeup Water Purifier (MUWP) System (See Figure 3.3-2). After filling the systems initially, small quantities of water will be required continuously to replace leakage and drainage from various systems within the power block (See Figure 3.3-2).

The MWP System will meet the demineralized water demand for STP 3 & 4 under normal and maximum operating conditions. Table 3.3-1 indicates the estimated demineralized water demand for both units under normal operating and maximum short-term steady-state conditions. These demineralized water demand projections are based on actual operational water use data for similarly designed systems (Reference 3.3-4), and are well bounded by MWP System capacity. Specifically, operating with a single reverse osmosis train running in a two-pass series configuration, the MWP System has the capacity to provide up to approximately 200 gpm of demineralized water. The MWP System is sized to provide a continuous maximum flow of approximately 500 gpm of demineralized water.

The MWP System sizing is based on meeting maximum flow conditions with four reverse osmosis units. In the normal mode, the reverse osmosis units will be configured as two parallel reverse osmosis trains with each reverse osmosis train

consisting of two reverse osmosis units in series (as a two-pass reverse osmosis configuration) to produce up to 400 gpm total demineralized water. The four reverse osmosis units will have the capability to be configured as four parallel single-pass reverse osmosis trains to produce instantaneous flows up to approximately 800 gpm total demineralized water for short time periods.

The MUWC System and the MUWP System both receive water from the MWP System. The MUWC System provides condensate quality water for both normal and emergency operations.

The MUWP System provides makeup water to the following (Reference 3.3-1):

- Condensate Storage Tank
- Reactor Building Cooling Water System
- Turbine Building Cooling Water System
- Diesel Generator Cooling Water System
- Liquid Radwaste System
- Standby Liquid Control Tank
- Decontamination Station
- Plant Chilled Water Systems
- Plant Laboratories
- Other Miscellaneous Uses
- The MUWC System supports the following (Reference 3.3-1):
 - Main Condenser Hotwell
 - Liquid Radwaste System
 - Residual Heat Removal System Flushing
 - High-Pressure Core Flooder System charging and flushing
 - Reactor Core Isolation Cooling System charging and flushing
 - Fuel Pool Skimmer Surge Tanks
 - Cleanup System Phase Separators and Cleanup System Filter Demineralizer
 - Condensate Filter and Demineralizer
 - Other Miscellaneous Uses

Discharges from the systems using demineralized water for makeup are routed to plant sumps, non-radioactive drains, or the liquid radwaste system before discharge.

The MUWC System and the MUWP System interface with the systems stated above but are not limited to only these systems. Most of these systems are closed looped; therefore, makeup will only need to be provided when water levels become low.

3.3.3 References

- 3.3-1 ABWR Design Control Document, GE Nuclear Energy, Revision 4, March 1997.
- 3.3-2 South Texas Project Units 1 and 2 Environmental Report Amendment 10, July 16, 1987.
- 3.3-3 Texas Commission on Environmental Quality, Permit to Discharge Wastes under Provisions of Section 402 of the Clean Water Act and Chapter 26 of the Texas Water Code-Texas Pollutant Discharge Elimination System (TPDES) Permit No. WQ0001908000, Austin, Texas, July 21, 2005.
- 3.3-4 Plant Water Balance," Fluor Nuclear Power Calculation No. U7-SITE-G-CALC-DESN-2001.

Table 3.3-1 STP 3 & 4 Water Flow Table

Stream	Stream Description	Normal [1] (gpm)	Maximum [1, 2, 7] (gpm)	Comments
	Groundwater (Well) Streams			
2	Plant Well Water Demand	975	3434	[11]
8	Well Water Demand for UHS System Makeup	885	3,203	[11]
4	UHS Tower Evaporation	566	2,122	
5	UHS Tower Blowdown	290	1,058	[4]
6	UHS Tower Circulating Water Flow	85,590	128,400	
7	UHS Tower Drift	5	10	[3]
13	UHS Seepage	24	13	
1	Well Water for Power Plant Makeup/Use	50	91	[6]
15	Potable Water	40	40	
16	Sanitary Waste	40	40	
19	Filter Effluent	50	91	
20	Filter Backwash Water	3	5	
21	Filter Backwash Waste	3	5	
27	Demineralized Water to Various Users	22	48	[8]
22	Reverse Osmosis Influent	33	72	
23	Reverse Osmosis Effluent	22	48	
24	Reverse Osmosis Reject	11	24	
26	Mixed Bed Effluent	22	48	
34	Liquid Radwaste Treatment Influent	28	60	
30	Fire Water System Makeup	10	10	
32	Oil/Water Separator Influent	15	15	
28	Equipment/Floor Washdown	5	5	
39	Consumptive Losses	17	38	
40	Demineralized Users Miscellaneous Drains Influent	5	10	
42	Startup/Flush Pond	0	0	[5]
	MCR Streams			
9	MCR Forced Evaporation from STP 3 & 4	23,190	49,000	[12]
11	MCR Circulating Water Flow	2.4 x 10 ⁶	2.4 x 10 ⁶	
12	MCR Seepage	0	0	[9]
14	MCR Rainfall	0	0	[9]
43	MCR Blowdown to Colorado River	0	138,240	[10]
44	MCR Makeup to UHS (Backup to Wells)	0	0	[11]

Table 3.3-1 STP 3 & 4 Water Flow Table (Continued)

Stream	Stream Description	Normal [1] (gpm)	Maximum [1, 2, 7] (gpm)	Comments
Surface Water (Colorado River) Streams				
3	Total Required River Water to MCR	22,799	47,489	
43	Total Discharge from MCR to River	0	138,240	[10]
Plant Effluent Streams				
10	Final Effluent Discharge Line to MCR	391	1,511	
35	Treated Liquid Radwaste	28	260	
37	Wastewater Retention Basin Discharge	33	53	
41	Demineralized Users Miscellaneous Drains Discharge	5	10	
17	Treated Sanitary Waste	40	140	
36	Total Low Volume Waste	28	43	
29	Equipment/Floor Washdown Waste	5	5	
31	Fire Water System Losses	10	10	
33	Oil/Water Separator Effluent	15	15	

Notes:

- The flow rate values are for STP 3 & 4.
- These flows are not necessarily concurrent.
- The cooling tower drifts are 0.005% of the tower circulating water flow for normal operation and 0.01% of the average tower circulating water flow for the 30 days following a design basis accident for maximum operation.
- The UHS cooling towers are assumed operating at three cycles of concentration.
- Startup flushes and startup pond discharge would occur only during the initial plant startup phase and potentially after unit outages when system flushes are required.
- Makeup water for demineralized water, potable water, and fire protection water, and makeup to the UHS basin would be from site wells. The MCR makeup will be from the Colorado River.
- Maximum evaporation from the UHS towers would occur during emergency, hot standby, hot standby with loss of AC, or shutdown conditions. All other maximum flows are during the power block peak demands for makeup water.
- For the normal condition, the reverse osmosis system is operating in a two-pass configuration, in maximum conditions the reverse osmosis is operating in a single-pass parallel configuration.
- The rainfall and seepage have been taken to be 0 gpm because STP 1 & 2 has already taken rainfall and seepage in consideration for its plant water balance (Reference 3.3-2). The addition of STP 3 & 4 has no impact on rainfall and insignificant impact on the seepage rates.
- The MCR has the ability to discharge water to the Colorado River at rates up to a maximum of 138,240 gpm (200 million gallons per day) in accordance with the existing Texas Pollutant Discharge Elimination System (TPDES) permit (Reference 3.3-3). The MCR has been blowdown infrequently during the past 20 years. Makeup water to the MCR during periods of blowdown evolution is not considered since the makeup requirements depend on the MCR water level and river flows.
- These maximum demands are estimated based on one unit in a planned refueling outage, and the second unit in a forced outage using worst case relative humidity. If the demand is higher than the permitted well water levels, UHS makeup for one or both units will be provided from the MCR.
- The forced evaporation shown includes STP 3 & 4 only. The natural evaporation of the MCR is constant and is not impacted by the number of units at the STP site. The natural evaporation of the MCR is not included in the discussion of surface water consumption in section 3.3.1. The normal forced evaporation rate based on a 93% load factor on a long-term basis is 21,600 gpm. The maximum forced evaporation rate is the daily maximum value based on a 100% load factor.
- Minimum water availability has no impact on the water balance for STP 3 & 4. The MCR accommodates fluctuations in makeup water availability. Change in the MCR level does not significantly impact the evaporation.
- Details on groundwater sources and construction requirements for plant water use are discussed in Sections 2.3, 4.2, and 3.9S. Information regarding STP 1 & 2 plant water use can be found in Reference 3.3-2.
- The normal value is based on subtracting the normal effluent plant discharge to the MCR from the normal forced

evaporation based on a 100% load factor. The maximum value is based on the average from the annual limit of consumptive use, which is 80,125 acre-ft/year, in accordance with the Certificate of Adjudication 14-5437 of the Texas Water Commission.

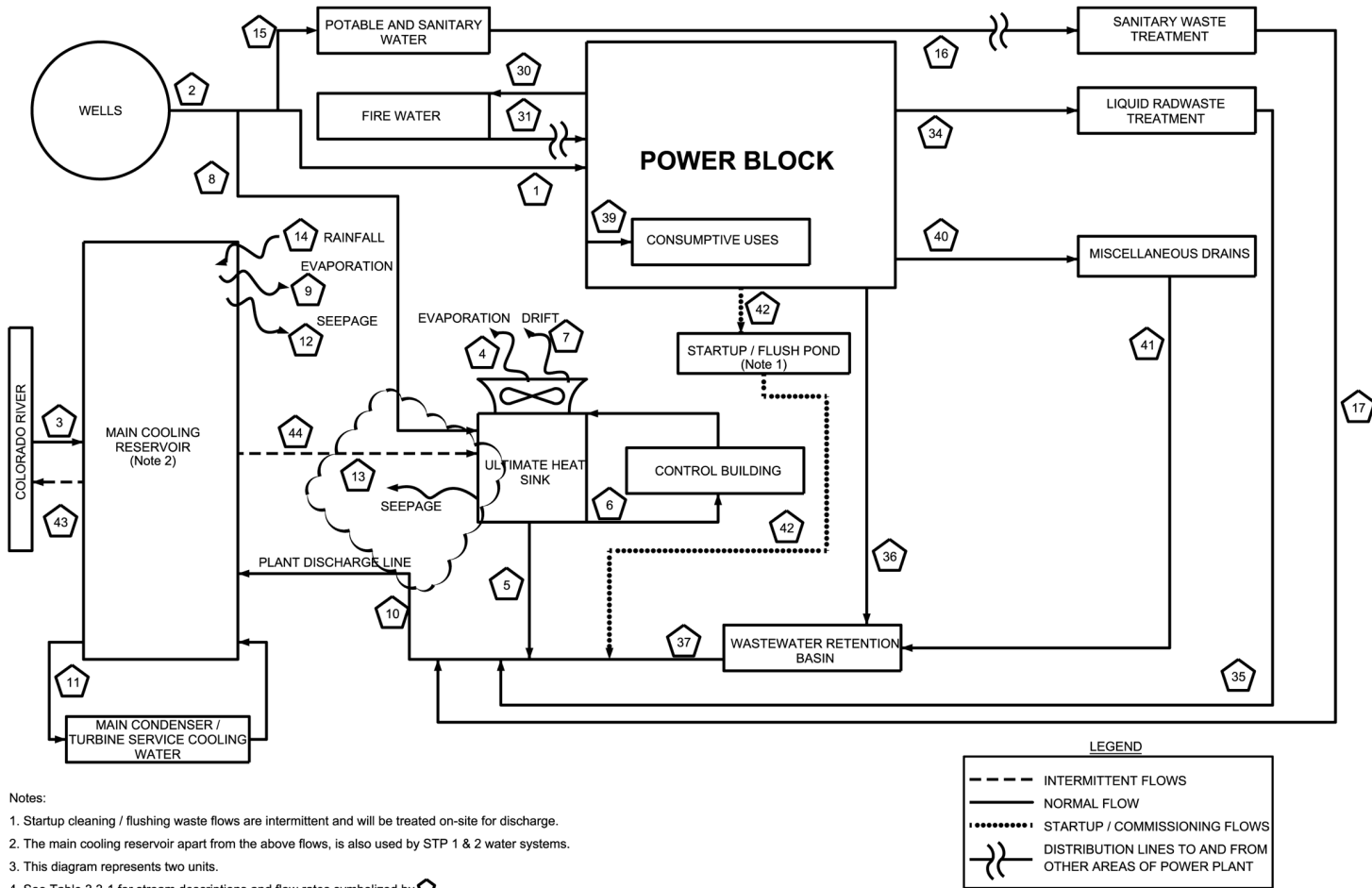

Notes:

1. Startup cleaning / flushing waste flows are intermittent and will be treated on-site for discharge.
2. The main cooling reservoir apart from the above flows, is also used by STP 1 & 2 water systems.
3. This diagram represents two units.
4. See Table 3.3-1 for stream descriptions and flow rates symbolized by 5.
5. This diagram is used to illustrate flows and is not representative of the final piping configurations.

Figure 3.3-1 Water Use Diagram Summary

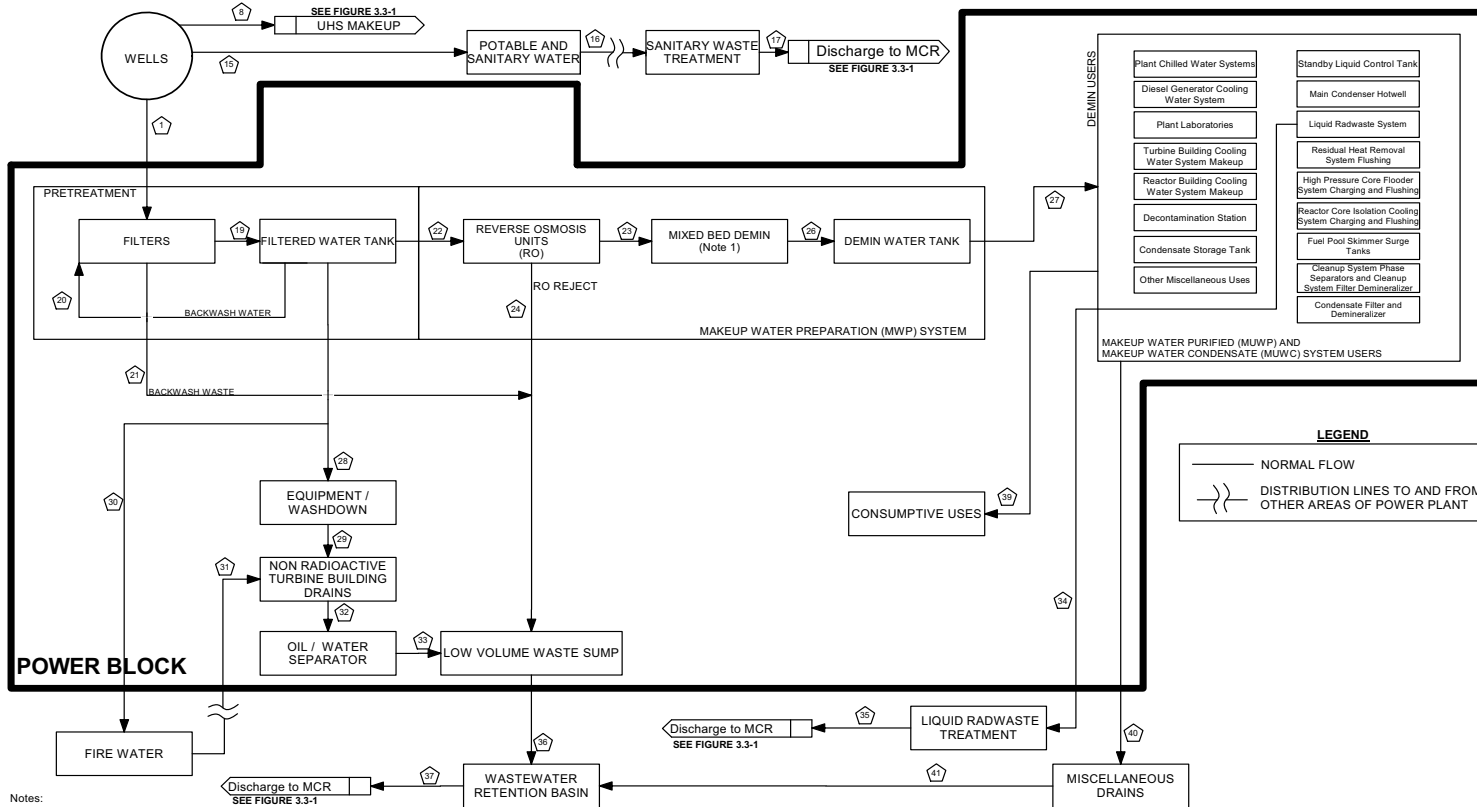

Notes:

1. Mixed Bed Units are non-regenerable type; Therefore, there will be no waste generated.
2. This diagram represents two units.
3. See Table 3.3-1 for stream descriptions and flow rates symbolized by .
4. This diagram is used to illustrate flows and is not representative of the final piping configurations.

Figure 3.3-2 Water Use Diagram Power Block Details