

## 6.2 Containment Systems

The information in this section of the reference ABWR DCD, including all subsections, tables, and figures, as modified by the STP Nuclear Operating Company Application to Amend the Design Certification rule for the U.S. Advanced Boiling Water Reactor (ABWR), "ABWR STP Aircraft Impact Assessment (AIA) Amendment Revision 3," dated September 23, 2010 is incorporated by reference with the following departures and supplements.

STD DEP T1 2.3-1 (Table 6.2-7)

STD DEP T1 2.4-2

STD DEP T1 2.4-3 (Tables 6.2-7, 6.2-8 and 6.2-10)

STD DEP T1 2.4-4

STD DEP T1 2.14-1 (Figure 6.2-38, Figure 6.2-40, Figure 6.2-41, Tables 6.2-7, 6.2-8 and 6.2-10)

STD DEP T1 3.4-1

STD DEP 6.2-2 (Tables 6.2-1 and 6.2-2, Figures 6.2-2, 6.2-3, 6.2-4, 6.2-5, 6.2-6a and b, 6.2-7a and b, 6.2-8a, 6.2-8b, 6.2-8c, 6.2-9, 6.2-10, 6.2-11, 6.2-12a and 6.2-12b, 6.2-13a and 6.2-13b, 6.2-14, 6.2-15, 6.2-22, 6.2-23a, 6.2-23b, 6.2-24, 6.2-25a, and 6.2-25b.)

STD DEP 6.2-3 (Tables 6.2-5, 6.2-6, 6.2-7, 6.2-8 and 6.2-10)

STD DEP 6C-1 (Table 6.2-2b, 6.2-2c)

STD DEP 9.2-7 (Table 6.2-9)

STD DEP 9.2-9 (Table 6.2-9)

STD DEP 9.3-2 (Tables 6.2-7, 6.2-8, 6.2-9 and 6.2-10)

STD DEP Admin (Tables 6.2-5, 6.2-7, 6.2-8 and 6.2-10)

### 6.2.1.1.1 Design Bases

STD DEP T1 2.14-1

- (9) *The Atmospheric Control System (ACS) establishes and maintains the containment atmosphere to less than 3.5% by volume oxygen during normal operating conditions to assure that maintain an inert atmosphere operation of two permanently installed recombiners can be initiated on high levels as determined by the Containment Atmospheric Monitoring System (CAMS).*

### 6.2.1.1.2.1 Drywell

STD DEP 6.2-2

*The maximum drywell temperature occurs in the case of a steamline break (469.7°C/173.2°C). Although this exceeds the ABWR drywell design temperature (171.1°C), it only exceeds it by 2.1°C and only for about 2 seconds. Due to thermal inertia, components in the drywell would not have sufficient time to reach the design limit temperature, and is below the design value (171.1°C).*

*The maximum drywell pressure occurs in the case of a feedwater line break (268.7/281.8 kPaG). The design pressure for the drywell (309.9 kPaG) includes 46%approximately 10% margin.*

### 6.2.1.1.2.2 Wetwell

STD DEP 6.2-2

*The wetwell chamber design pressure is 309.9 kPaG and design temperature is 403.9°C/104°C.*

*Under normal plant operating conditions, the maximum suppression pool water and wetwell airspace temperature is 35°C or less. Under blowdown conditions following an isolation event or LOCA, the initial pool water temperature may rise to a maximum of 76.7°C.The continued release of decay heat after the initial blowdown following an isolation event or LOCA may result in suppression pool temperatures as high as 97.2 99.6°C. The Residual Heat Removal (RHR) System is available in the Suppression Pool Cooling mode to control the pool temperature. Heat is removed via the RHR heat exchanger(s) to the Reactor Building Cooling Water (RCW) System and finally to the Reactor Service Water (RSW) System. The RHR System is described in Subsection 5.4.7.*

### 6.2.1.1.3.3 Accident Response Analysis

STD DEP 6.2-2

*The containment design pressure and temperature were established based on enveloping the results of this range of analyses plus providing NRC prescribed margins.*

*For the ABWR pressure suppression containment system, the peak containment pressure following a LOCA is very relatively insensitive to variations in the size of the assumed primary system rupture. This is because the peak occurs late in the blowdown and is determined in very large part by the transfer of the noncondensable gases from the drywell to the wetwell airspace. This process is not significantly influenced by the size of the break. In addition, there is a 15%an approximately 10% margin between the peak calculated value and the containment design pressure that will easily accommodate small variations in the calculated maximum value.*

~~Tolerances associated with fabrication and installation may result in the as-built size of the postulated break areas being 5% greater than the values presented in this chapter. Based on the above, these as-built variations would not invalidate the plant safety analysis presented in this chapter and Chapter 15 of the RPV nozzles have been taken into account in this analysis.~~

### 6.2.1.1.3.3.1 Feedwater Line Break

STD DEP T1 2.4-2

STD DEP 6.2-2

~~Immediately following a double-ended rupture in one of the two main feedwater lines just outside the vessel (Figure 6.2-1), the flow from both sides of the break will be limited to the maximum allowed by critical flow considerations. The effective flow area on the RPV side is given in Figure 6.2-20, 0.08399 m<sup>2</sup>. Reverse RPV flow in the second FW line is prevented by check valves shown in Figure 6.2-1. During the inventory depletion period, subcooled blowdown occurs and the effective flow area at saturated condition is much less than the actual break area. The detailed calculational method is provided in Reference 6.2-1.~~

~~The maximum possible feedwater flow rate was calculated to be 164% of nuclear boiler rated (NBR), based on the response of the feedwater pumps to an instantaneous loss of discharge pressure. Since the Feedwater Control System will respond to decreasing RPV water level by demanding increased feedwater flow, and there is no FWLB sensor in the design, this maximum feedwater flow was conservatively assumed to continue for 120 seconds (Figure 6.2-3). This is very conservative because:~~

- ~~(1) All feedwater system flow is assumed to go directly to the drywell.~~
- ~~(2) Flashing in the broken feedwater line was ignored.~~
- ~~(3) Initial feedwater flow was assumed to be 105% NBR.~~
- ~~(4) The feedwater pump discharge flow will coastdown as the feedwater system pumps trip due to low suction pressure. During the inventory depletion period, the flow rate is less than 164% because of the highly subcooled blowdown. A feedwater line length of 100m was assumed on the feedwater system side.~~

In order to provide further assurance of conservatism, FWLB mitigation is added to the ABWR design. The system is described in Section 7.3.1.1.2. The specific enthalpy time history, assuming the break flow of Figure 6.2-3, is shown in Figure 6.2-4. Initial reactor power is assumed to be 102% NBR.

### 6.2.1.1.3.3.1.1 Assumptions for Short-Term Response Analysis

STD DEP 6.2-2

The response of the Reactor Coolant System and the Containment System during the short-term blowdown period of the accident has been analyzed using the following assumptions:

- (1) ~~The initial conditions for the FWLB accident are such that system energy is maximized and the system mass is minimized~~maximize the containment pressure response. That is:
  - (a) The reactor is operating at 102% of the rated thermal power, which maximizes the post-accident decay heat.
  - (b) The initial suppression pool mass is at the ~~low~~high water level.
  - (c) The initial wetwell air space volume is at the high water level.
  - (d) The suppression pool temperature is the operating maximum ~~temperature~~value.
- (4) ~~The main steam isolation valves (MSIVs) start closing at 0.5 s after the accident. They are fully closed in the shortest possible time (at 3.5 s) following closure initiation.~~The turbine stop valves are closed in 0.2 seconds after reactor trip/turbine trip (RT/TT). By assuming rapid closure of these valves, the RPV is maintained at a high pressure, which maximizes the calculated discharge of high energy water into the drywell.
- (5) ~~The vessel depressurization flow rates are calculated using Moody's homogeneous equilibrium model (HEM) for the critical break flow (Reference 6.2-2). The vessel depressurization flow rates are calculated using Moody's homogeneous equilibrium model (HEM) for the critical break flow~~critical flow model (Reference 6.2-2). The break area on the RPV side for this study is shown in Figure 6.2-2. During the inventory depletion period, subcooled blowdown occurs and the effective break area at saturated conditions is much less than the actual area. The detailed calculational method is provided in Reference 6.2-1.

~~Reactor vessel internal heat transfer is modeled by dividing the vessel and internals into six metal nodes. A seventh node depends on the fluid (saturated or subcooled liquid, saturated steam) covering the node at the time. The assumptions include:~~

- ~~(a) The center of gravity of each node is specified as the elevation of that node.~~
  - ~~(b) Mass of water in system piping (except for HPCF and feedwater) is included in initial vessel inventory.~~
  - ~~(c) Initial thermal power is 102% of rated power at steady state conditions with corresponding heat balance parameters which correspond to turbine control valve constant pressure of 6.75 MPaA.~~
  - ~~(d) Pump heat, fuel relaxation, and metal water reaction heat are added to the ANSI/ANS 5.1 decay heat curve plus 20% margin.~~
  - ~~(e) Initial vessel pressure is 7.31 MPaA.~~
- (6) ~~There are two HPCF Systems, one RCIC System, and three RHR Systems in the ABWR. One HPCF System, one RCIC System and two RHR Systems are assumed to be available. HPCF flow cannot begin until 36 seconds after a break, and then the flow rate is a function of the vessel to wetwell differential pressure. Rated HPCF flow is 182 m<sup>3</sup>/h per system at 8.12 MPaD and 727 m<sup>3</sup>/h, per system at 0.69 MPaD. Rated RHR flow is 954 m<sup>3</sup>/h at 0.28 MPaD with shutoff head of 1.55 MPaD. Rated RCIC flow is 182 m<sup>3</sup>/h with reactor pressure between 8.12 MPaG and 1.04 MPaG, and system shuts down at 0.34 MPaG.~~ Influence of the ECCS systems is minimal since the time interval analyzed for short-term is approximately the same time as the response time of associated systems injections into the RPV.
- (8) The wetwell airspace temperature is allowed to exceed the suppression pool temperature as determined by a mass and energy balance on the airspace.
  - (9) Wetwell and drywell wall and structure heat transfer are ignored.
  - (10) Actuation of SRVs is modeled.
  - (11) ~~Wetwell-to-drywell vacuum breakers are not modeled~~ are modeled but do not open.
  - (12) Drywell and wetwell sprays and RHR cooling mode are not modeled.
  - (13) ~~The dynamic backpressure model is used.~~ Not Used
  - (14) Initial drywell conditions are 0.107 MPa, 57°C and 20% relative humidity.
  - (15) Initial wetwell airspace conditions are 0.107 MPa, 35°C and 100% relative humidity.

- (16) The drywell is modeled as a single node. All break flow into the drywell is homogeneously mixed with the drywell inventory.
- (17) ~~Because of the unique containment geometry of the ABWR, the inert atmosphere in the lower drywell would not transfer to the wetwell until the peak pressure in the drywell is achieved. Figure 6.2-5 shows the actual case and the model assumption. Because the lower drywell is connected to the drywell connecting vent, no gas can escape from the lower drywell until the peak pressure occurs. This situation can be compared to a bottle whose opening is exposed to an atmosphere with an increasing pressure. The contents of the lower drywell will start transferring to the wetwell as soon as the upper drywell pressure starts decreasing. A conservative credit for transfer of 50% of the lower drywell contents into the wetwell was taken. Not Used~~

#### 6.2.1.1.3.3.1.2 Assumptions for Long-Term Cooling Analysis

STD DEP 6.2-2

Following the blowdown period, the ECCS discussed in Section 6.3 provides water for core flooding, containment spray, and long-term decay heat removal. The containment pressure and temperature response during this period was analyzed using the following assumptions:

- (1) ~~The ECCS pumps are available as specified in Subsection 6.3.1.1.2 (except one low pressure flooder feeding a broken feedwater line, in case of a FWLB). There are two HPCF Systems, one RCIC System, and three RHR Systems in the ABWR. All motor operated pump systems (HPCF and RHR) are assumed to be available to maximize pump heat into the suppression pool. A single failure of one RHR heat exchanger was assumed for conservatism.~~
- (2) The ANSI/ANS-5.1-1979 decay heat plus 2-sigma uncertainty is used. Fission energy, fuel relaxation heat, and pump heat are included.
- (3) ~~The suppression pool is the only heat sink available in the containment system.~~ volume corresponds to the low water level.
- (4) ~~After 10 minutes, the RHR heat exchangers are activated to remove energy via recirculation cooling of the suppression pool with the RCW System and ultimately to the RSW System. This is a conservative assumption, since the RHR design permits initiation of containment cooling well before a 10 minute period (see response to Question 430.26). After 30 minutes, one RHR heat exchanger is activated to remove energy via recirculation cooling of the suppression pool and one RHR heat exchanger is activated to remove energy via drywell sprays with the RCW System and ultimately to the RSW System.~~

- (6) ~~The lower drywell flooding of 815m<sup>3</sup> was assumed to occur 70 seconds after scram. During the blowdown phase, a portion of break flow flows into the lower drywell. This is conservative, since lower drywell flooding will probably occur at approximately 110 to 120 second time period.~~ Water which is from the lower drywell is assumed to be mixed with the suppression pool to calculate the bulk average temperature.
- (7) ~~At 70 seconds, the feedwater specific enthalpy becomes 118.7 J/g (100 C saturation fluid enthalpy).~~ Structural heat sinks are modeled in the containment system.

### 6.2.1.1.3.3.1.3 Short-Term Accident Responses

#### STD DEP 6.2-2

~~The calculated containment pressure and temperature responses for a feedwater line break are shown in Figures 6.2-6 and 6.2-7, respectively. The peak pressure (268.7 kPaG) and temperature (140°C) occur in the drywell. The containment design pressure of 309.9 kPaG is 115% of the peak pressure.~~

~~The drywell pressurization is driven by the wetwell pressurization for stable peaks. The wetwell pressurization is a function of three major parameters:~~

- ~~(1) The increased wetwell air mass caused by the addition of drywell air~~
- ~~(2) Compression of the airspace volume due to increased suppression pool volume~~
- ~~(3) Increased vapor partial pressure from increasing suppression pool temperature~~

~~The suppression pool volume increase is caused by the liquid addition to the containment system from the broken feedwater line. Contribution of these parameters to wetwell pressurization is about 80% by the increased air mass, 15% by the compression effects, and 5% by the increased vapor partial pressure. Once air carryover from the drywell is completed, the wetwell and, subsequently, the drywell pressure peak occurs as the volumetric compression is completed and the pool volume begins to decrease due to the drawdown effects of the ECES flow. Since the suppression pool volume continues to decrease as the ECES flow continues, the short term pressure peak is the peak pressure for the transient. The containment pressure response (Figure 6.2-6) covers the pool swell phase of the short-term containment response. The drywell pressure peaks soon after bubble breakthrough as the break flow continues to push the drywell air to the wetwell. The wetwell pressure also continues to climb after this phase as the air carryover from the drywell continues.~~

### 6.2.1.1.3.3.1.4 Long-Term Accident Responses

#### STD DEP 6.2-2

*In order to assess the adequacy of the containment system following the initial blowdown transient, an analysis was made of the long-term temperature and pressure response following the accident. The analysis assumptions are those discussed in Subsection 6.2.1.1.3.3.1.2.*

*The short term pressure peak (268.7 kPaG) of Figure 6.2-6 is the peak pressure for the whole transient. Figure 6.2-8 shows temperature time histories for the suppression pool, wetwell, and drywell temperatures. The peak pool temperature (99.6°C) is reached at 6600 seconds (1.833 hours). This is less than the suppression pool temperature value of 100°C which is used in the net positive suction head available (NPSHA) calculations for RHR and HPCF.*

### 6.2.1.1.3.3.2 Main Steamline Break

STD DEP 6.2-2

*A schematic of the ABWR main steamlines, with a postulated break in one of the main steamlines, is shown in Figure 6.2-9. The main steamline (MSL) break is a double-ended break with one end fed by the RPV directly through the broken line, and the other fed by the RPV through the unbroken main steamlines until the MSIVs are closed. Once the MSIVs are closed, the break flow is only from the RPV through the broken line.*

Each MSL contains a flow limiter built into the MSL nozzle on the RPV with a throat area of 0.09848 m<sup>2</sup>, as shown in Figure 6.2-9. This flow limiter provides the effective break area for the vessel side.

Flow from the condenser side of the break continues for 0.5 seconds, at which time the MSIVs begin to close on high flow signal. A valve stroke time of 4.5 seconds is used for the MSIV closure. Flow from the condenser side of the break is ramped down to zero between 0.5 and 5.0 seconds. The effective break area used for the MSL is shown in Figure 6.2-10. More detailed descriptions of the MSL break model are provided in the following:

- (1) Each MSL contains a flow limiter built into the MSL nozzle on the RPV with a throat area of 0.0983m<sup>2</sup>, as shown in Figure 6.2-9.*
- (2) The break is located in one MSL at the inboard MSIV.*
- (3) During the inventory depletion period, the flow multiplier of 0.75 is applied (Reference 6.2-1).*
- (4) The flow resistance of open MSIVs is considered. A conservative value of 2.062 for pressure loss coefficient for two open MSIVs was taken. The nominal value is approximately 3.0. When the open MSIV resistance is considered, the flow chokes at the MSIV on the piping side as soon as the inventory depletion period ends. The effective flow area on the piping side reduces to 70% of a frictionless piping area. The value of 70% applies to flow of steam and twophase mixture with greater than 15% quality.*



~~This assumption is quite conservative because all other resistances in piping are ignored and the flow in the steamline within a one to two second period is either all steam or a two phase mixture of much greater than 15% quality.~~

- (5) ~~MSIVs are completely closed at a conservative closing time of 5.5 seconds (0.5 seconds greater than the maximum closing time plus instrument delay), in order to maximize the break flow.~~

#### 6.2.1.1.3.3.2.1 Assumptions for Short-Term Response Analysis

STD DEP 6.2-2

The response of the reactor coolant system and the containment system during the short-term blowdown period of the MSLB accident is analyzed using the assumptions listed in the above subsection and Subsection 6.2.1.1.3.3.1.1 for the feedwater line break, with the following exceptions: except feedwater mass flow rate for a MSL break was assumed to be 130% NBR for the case where no operator action is assumed to control water level. Additional cases were run with feedwater mass flow rate regulated to control RPV water level or with no feedwater flow based on an assumed loss of offsite power.

- (1) ~~The vessel depressurization flow rates are calculated using the Moody's HEM for the critical break flow.~~
- (2) ~~The turbine stop valve closes at 0.2 second. This determines how much steam flows out of the RPV, but does not affect the inventory depletion time on the piping side.~~
- (3) ~~The break flow is saturated steam if the RPV collapsed water level is below the MSL elevation; otherwise, the flow quality is the vessel average quality. This case provides the limiting drywell temperature.~~

~~Another case was evaluated with the assumption that the two phase level swell would reach the main steam nozzle in one second, thereby changing the flow quality to the RPV average quality after one second. This case provides a higher drywell pressure but a lower drywell temperature than the first assumption.~~

- (4) ~~The feedwater mass flow rate for a MSL break was assumed to be 130% NBR for 120 seconds. This is a standard MSL break containment analysis assumption based on a conservative estimate of the total available feedwater inventory and the maximum flow available from the feedwater pumps with discharge pressure equal to the RPV pressure. The feedwater enthalpy was calculated as described for the FWL break (Subsection 6.2.1.1.3.3.1.1) for 130% NBR flow, and is shown in Figure 6.2-11.~~
- (5) ~~The SRVs are not actuated.~~

### 6.2.1.1.3.3.2.3 Short-Term Accident Response

STD DEP 6.2-2

*Figures 6.2-12 through 6.2-15 and 6.2-13 show the pressure and temperature responses of the drywell and wetwell during the blowdown phase of the steamline break accident.*

The maximum drywell temperature (173.2°C) is predicted to occur for the steamline break. The MSLB with two-phase blowdown starting when the RPV collapsed water level is at or below the main steamline nozzle provides the highest peak drywell temperature. The peak drywell air temperature is 169.7/173.2°C, below the which is above the design value of 171.1°C, and is the limiting one as compared to the FWLB peak temperature. As noted in Section 6.2.1.1.2.1, this peak calculated drywell temperature exceeds the design limit for only 2 seconds. The peak drywell pressure for the MSLB remains below that for the FWLB, which becomes the most limiting. The peak drywell pressure is below the design pressure. The MSLB is the limiting event for peak drywell temperature. The FWLB is the most limiting for drywell pressure.

### 6.2.1.1.3.3.2.4 Long-Term Accident Response

STD DEP 6.2-2

*The long term containment pressure and temperature responses following the MSLB accident remain below those for the feedwater line break, which is the most limiting event. The long-term containment pressure response following the MSLB accident remains below that for the feedwater line break. The long-term temperature response remains below that for the peak achieved in the short term for the steam line break shown in Figure 6.2-13.*

### 6.2.1.1.3.4.1 Short-Term Pressurization Model

STD DEP 6.2-2

*The analytical models, assumptions and methods used to evaluate the containment response during the reactor blowdown phase of a LOCA are described in References 6.2-1, and 6.2-2 similar to those for the feedwater line break.*

#### 6.2.1.1.4 Negative Pressure Design Evaluation

STD DEP 6.2-2

*Drywell depressurization following a ~~FWL~~BL~~OCA~~ results in the severest pressure transient in the drywell; this transient is therefore used in sizing the Wetwell-to-Drywell Vacuum Breaker System (WDVBS). The most severe depressurization in the wetwell is caused by wetwell spray actuation subsequent to a stuck open relief valve. The analysis of this transient shows that the Primary Containment Vacuum Breaker System (PCVBS) is not required.*

#### 6.2.1.1.7 Asymmetric Loading Conditions

STD DEP Admin

*Localized pipe forces, pool swell and SRV actuation are asymmetric pressure loads which act on the containment and internal structure (see Subsection ~~6.2.1.1.5~~ 6.2.1.1.6 for magnitudes of pool swell and SRV loads).*

#### 6.2.1.7 Instrumentation Requirements

*In addition to the ABWR design features, the control of the suppression pool cleanliness is a significant element of minimizing the potential for strainer plugging. ~~The COL applicant will review the issue of maintaining the suppression pool cleanliness, and propose to the NRC Staff an acceptable method for assuring that the suppression pool cleanliness is maintained. Methods shall be considered for removing, at periodic intervals, sediment and floating or sunk debris from the suppression pool that the SPCU does not remove. See Subsection 6.2.7.3 for COL license information.~~*

*Refer to Appendix 6C for additional information on BWR design guidelines.*

#### 6.2.1.7.1 Suppression Pool Cleanliness Program

##### 6.2.1.7.1.1 Purpose

This operational program is to ensure that the primary containment is free from debris that could become dislodged in an accident and be transported to the ECCS suction strainers and interfere with their proper functioning during a design basis event.

##### 6.2.1.7.1.2 Scope

This program applies to the primary containment, including the drywell and suppression pool, for STP Units 3 and 4. This program has design, maintenance and operational elements. This program is comprised of: (1) design change control to ensure that material whose susceptibility to damage resulting in uncontrolled debris is limited and cannot be replaced with material with greater susceptibility; (2) restricted access to primary containment during reactor operations and refueling periods; (3) suppression pool cleanup system operation to maintain S/P cleanliness; (4) foreign material exclusion and housekeeping requirements to ensure that foreign material that could be detrimental to ECCS strainer operation if left in primary containment is removed prior to containment close out; and (5) drywell, S/P, and strainer inspections

following outages to ensure that no debris is present prior to the containment being closed out in preparation for operation.

The program is based on ABWR Operating Experience, Electric Power Research Institute (EPRI) guidelines contained in EPRI TR 1016315, "Nuclear Maintenance Applications Center: Foreign Material Exclusion Guidelines" and Institute of Nuclear Power Operations (INPO) guidance in INPO 07-008, "Guidelines for Achieving Excellence in Foreign Material Exclusion (FME)."

#### **6.2.1.7.1.3 Responsibilities**

The operations and maintenance organizations have overall responsibility for the procedures that implement this program. There is a suppression pool cleanliness program owner, whose responsibility is to have overview of all aspects of this program, including reviewing procedures, training station personnel, being aware of industry operating experience, and on an ongoing basis assessing the overall effectiveness of the program.

#### **6.2.1.7.1.4 Standards**

There will be no fibrous or calcium silicate insulation inside the primary containment. All insulation will be RMI-type which will not pass through the ECCS suction strainers. Design change control will ensure that the RMI is not replaced with fibrous or calcium silicate insulation.

The primary containment will be designated as a Foreign Material Exclusion (FME) Zone 1 in accordance with the INPO Definition. This is an area where loss of FME could result in personnel injury, nuclear fuel failure, reduced safety system or station availability, or an outage extension or significant cost for recovery and is the highest level of FME defined by INPO. All activities associated with suppression pool cleanliness will be done in accordance with the STP 3 & 4 Quality Assurance Program.

The S/P cleanup system will be operated as necessary to maintain the water chemistry in the S/P comparable to that required for refueling water.

The primary containment atmosphere is inerted during reactor operations. Therefore, access to the primary containment is effectively prohibited.

#### **6.2.1.7.1.5 Key Elements of the Suppression Pool Cleanliness Program**

During refueling outages, the containment is a FME Zone 1 area. In addition, strict house keeping controls are in place to ensure that only needed material is brought into containment and that work areas are restored to their original conditions following completion of the work. Prior to entry into the containment during scheduled or unscheduled outages, all material will be accounted for and documented.

Following each refueling outage, a detailed visual inspection is performed of the primary containment to identify and remove any loose debris. This detailed inspection is controlled by plant procedures in accordance with the Procedure Development

Program. All debris identified will be documented and entered into the corrective action program for trending and potential action.

In addition a remote visual inspection will be performed of the Residual Heat Removal (RHR), Reactor Core Isolation Cooling (RCIC), and High Pressure Core Flooder (HPCF) suction strainers and the S/P floor to ensure there is no debris present. This inspection will be focused on the presence of debris in the suction strainers but will also look for any structural gaps that would allow debris to bypass the strainer flow holes. Results of these inspections will be documented in the procedure and in the corrective action program. Debris that is identified will be removed and any strainer structure gaps will be assessed and repaired if necessary.

The S/P cleanup system will normally be operated in alignment with a train of the fuel pool cleanup filter/demineralizers to ensure S/P water quality. Floating debris and sediment in the suppression pool not removed by the Suppression Pool Cleanup System will be removed during refueling outages.

In the unlikely event of a primary containment entry during the operating cycle, a close-out inspection will be performed prior to the return to operation.

#### **6.2.1.7.1.6 Acceptance Criteria**

Procedures related to suppression pool cleanliness will have defined acceptance criteria that must be met prior to closing containment and returning to power. Acceptance criteria will be absence of debris in the primary containment non suppression pool areas. For the strainers themselves, the acceptance criteria will be that the strainer inlets are not restricted, the strainer screens are not plugged, and the strainer structure does not have any structural gaps. For the suppression pool, the acceptance criteria will be the absence of debris and sediment.

There is a documented close-out of containment following completion of all cleanliness inspections and prior to resumption of power operation.

#### **6.2.1.7.1.7 Procedural Controls**

Station procedures that implement the suppression pool cleanliness program will be developed in accordance with the Procedure Development Plan described in Section 13.5. These procedures will address control of materials, access to the containment, inspection and cleanup of containment, inspection and cleanup of the strainers, and inspection and cleanup of the suppression pool.

#### **6.2.1.7.1.8 Implementation**

The suppression pool cleanliness program will be implemented prior to the initiation of the startup test program.

### 6.2.1.7.1.9 Corrective Action Program

Adverse conditions from the containment and strainer inspections will be documented in the STP 3 & 4 corrective action program to ensure they are properly addressed and to allow trending and analysis of results.

### 6.2.1.7.1.10 Audits

Periodic audits will be performed by the STP 3 & 4 Quality Assurance department on this program.

### 6.2.1.7.1.11 Operating Experience

Operating experience at other plants will be periodically assessed for lessons learned that could be applied to the STP 3 & 4 program.

### 6.2.2.3.1 System Operation and Sequence of Events

STD DEP T1 2.4-4

STD DEP 6.2-2

- (4) ~~Containment cooling is initiated after 10 minutes (see Response to Question 430-26).~~ Containment cooling is initiated after 30 minutes.

*Analysis of the net positive suction head (NPSH) available to the RHR and HPCF pumps in accordance with the recommendations of Regulatory ~~Guide~~ Guides 1.1 and 1.82 is provided in Tables 6.2-2b and 6.2-2c, respectively.*

### 6.2.4.3.2.1.1.6 Recirculation Pump Seal Purge Water Supply Line

STD DEP 6.2-3

*The evaluations for previous similar designs show that the consequences of breaking the line are less severe than those of failing an instrument line. The recirculation pump seal water line is 20A Quality Group B from the manual shutoff valve located close to the recirculation pump motor housing through the ~~second~~ excess flow check valve (located outside the containment). From the ~~second~~ excess flow check valve to the CRD connection, the line is Quality Group D. An orifice is located inside the containment and if the line is postulated to fail and either one of the excess flow check valve check valves is assumed not to close (single active failure), the flow rate through the broken line is calculated to be substantially less than permitted for a broken instrument line. Therefore, the two check valves in series this configuration provides ~~provide~~ sufficient isolation capability for postulated failure of the line.*

### 6.2.4.3.2.1.2 Effluent Lines

STD DEP Admin

*Table ~~6-2-3~~ 6.2-76.2-6 contains those effluent lines that comprise the reactor coolant pressure boundary and which penetrate the containment.*

#### 6.2.4.3.4 Evaluation of Containment Purge and Vent Valves Isolation Barrier Design

STD DEP T1 3.4-1

STD DEP 6.2-3

*Protection of the containment purge system CIVs from the effects of flood and dynamic effects of pipe breaks will be provided in accordance with Sections 3.4 and 3.6. The CIVs are air-operated with pilot ~~DC~~ AC solenoid valve. The power to the ~~DC~~ AC solenoid valve is supplied from the ~~DC~~ Vital AC distribution system to the ~~demultiplexer I/O device~~ I/O device for the valve. Both the supply and return lines for the ~~DC~~ AC are fused at the ~~multiplexer I/O device~~ I/O device so that faults are isolated and do not propagate back up into the portions of the ~~DC~~ Vital AC system common with other systems. This is also discussed in the Fire Hazard Analysis in Section 9A.5.*

#### 6.2.5 Combustible Gas Control in Containment

STD DEP T1 2.14-1

*The Atmospheric Control System (ACS) is provided to establish and maintain an inert atmosphere within the primary containment during all plant operating modes except during shutdown for refueling or equipment maintenance and during limited periods of time to permit access for inspection at low reactor power. ~~The Flammability Control System (FCS) is provided to control the potential buildup of hydrogen and oxygen from design basis metal water reaction and radiolysis of water. The objective of these systems is to preclude combustion of hydrogen causing damage to essential equipment and structures. The COL applicant is required to provide a comparison of costs and benefits for any optional alternate system of hydrogen control.~~*

##### 6.2.5.1 Design Bases

STD DEP T1 2.14-1

*Since there is no design requirement for the ACS ~~or FCS~~ in the absence of a LOCA and since there is no design basis accident in the ABWR that results in core uncover or fuel failures, the following requirements mechanistically assume that a LOCA producing the design basis quantities of hydrogen and oxygen has occurred. Following are criteria that serve as the bases for design:*

- (1) *The hydrogen generation from metal-water reaction is defined in Regulatory Guide 1.7.*
- (2) *The hydrogen and oxygen generation from radiolysis is defined in Regulatory Guide 1.7.*
- (7) *~~The FCS is capable of controlling combustible gas concentrations in the containment atmosphere for the design-bases LOCA without relying on purging and without releasing radioactive material to the environment.~~ Not Used*

- (8) ~~The ACS and FCS together are~~ designed to maintain an inert primary containment after the design-bases LOCA, assuming a single-active failure. ~~The backup purge function need not meet this criterion.~~
- (12) The ACS is non-safety class except as necessary to assure primary containment integrity (penetrations, isolation valves). ~~The ACS and FCS are~~ designed and built to the requirements specified in Section 3.2.

#### 6.2.5.2.1 General

STD DEP T1 2.14-1

~~The FCS and ACS are systems~~ system is designed to control the environment within the primary containment. ~~The FCS provides control over hydrogen and oxygen generated following a LOCA. In an inerted containment, mixing of any hydrogen generated is not required.~~ Any oxygen evolution from radiolysis is very slow such that natural convection and molecular diffusion is sufficient to provide mixing. Spray operation will provide further assurance that the drywell or wetwell is uniformly mixed. ~~The FCS consists of the following features:~~

- (1) ~~(1) The FCS has two recombiners installed in the secondary containment. The recombiners process the combustible gases drawn from the primary containment drywell.~~
- (2) ~~(2) The FCS is activated when a LOCA occurs. The oxygen and hydrogen remaining in the recombiners after having been processed are transmitted to the suppression pool.~~

The ACS provides and maintains an inert atmosphere in the primary containment during plant operation. The system is not designed as a continuous containment purging system. The ACS exhaust line isolation valves are closed when an inert condition in the primary containment has been established. The nitrogen supply makeup lines, compensating for leakage, provide a makeup flow of nitrogen to the containment. If a LOCA signal is received, the ACS valves close. Nitrogen purge from the containment occurs during shutdown for personnel access. Purging is accomplished with the containment inlet and exhaust isolation valves opened to the selected exhaust path and the nitrogen supply valves closed. Nitrogen is replaced by air in the containment (see Item (3) Shutdown-Deinerting below this subsection). The system has the following features:

- (3) The redundant oxygen analyzer system (CAMS) measures oxygen in the drywell and suppression chamber. Oxygen concentrations are displayed in the main control room. ~~Description of safety related display instrumentation for containment monitoring is provided in Chapter 7. Electrical requirements for equipment associated with the combustible gas control system are in accordance with the appropriate IEEE standards as referenced in Chapter 7.~~

The following interfaces with other systems are provided:



- (1) *Residual Heat Removal System (RHR): The RHR System provides postaccident suppression pool cooling, as necessary, following heat dumps to the pool, including the exothermic heat of reaction released by the design basis metal-water reaction. This heat of reaction is very small and has no real effect on pool temperature or RHR heat exchanger sizing. The wetwell spray portion of the RHR may be activated during a LOCA help mixing by reducing pocketing. Wetwell spray would also serve to accelerate deaeration of the suppression pool water, though the impact of the dissolved oxygen on wetwell airspace oxygen concentration is very small. ~~The RHR System also provides cooling water to the exhaust flow from the FGS.~~*
- (6) *Containment Atmospheric Monitoring System: Monitors oxygen levels in the wetwell and drywell ~~during accident conditions~~ to confirm the primary containment oxygen level is kept within limits.*

#### 6.2.5.2.6.1 General

STD DEP 6.2-3

- (6) *The rupture disk is part of the primary containment boundary and is able to withstand the containment design pressure (309.9 kPa) with no leakage to the environment. It is also capable of withstanding full vacuum in the wetwell vapor space without leakage. The disk ruptures at 617.8 kPa due to overpressurization during a severe accident as required to assure containment structural integrity. As potential backup to a leaking, fractured or improperly sealed rupture disk, the two valves upstream of the disk can be closed. These valves are safety-related and are subjected to all testing required for normal isolation valves. The solenoids in these valves are ~~DC~~ powered by vital AC (VAC). These valves are capable of closing against pressures up to 617.8 kPaG.*

#### 6.2.5.2.7 ~~Flammability Control System~~ Not Used

STD DEP T1 2.14-1

- (1) *~~All pressure containing equipment, including piping between components is considered an extension of the containment, and designed to ASME Section III Safety Class 2 requirements. Independent drywell and suppression chamber penetrations are provided for the two recombiners. Each penetration has two normally closed isolation valves; one pneumatically operated and one motor operated. The system is designed to meet Seismic Category I requirements. The recombiners are in separate rooms in the secondary containment and are protected from damage by flood, fire, tornadoes and pipe whip.~~*
- (2) *~~After a LOCA, the system is manually actuated from the control room when high oxygen levels are indicated by the containment atmospheric monitoring system (CAMS). (If hydrogen is not present, oxygen concentrations are controlled by nitrogen makeup.) Operation of either recombiner will provide~~*

~~effective control over the buildup of oxygen generated by radiolysis after a design basis LOCA. Once placed in operation the system continues to operate until it is manually shut down when an adequate margin below the oxygen concentration design limit is reached.~~

#### 6.2.5.4 Tests and Inspections

STD DEP T1 2.14-1

*Preoperational tests of the ACS and FCS are conducted during the final stages of plant construction prior to initial startup.*

#### 6.2.5.5 Instrumentation Requirements

STD DEP T1 2.14-1

*As discussed in Subsection 6.2.5.2, ~~safety-grade~~ oxygen monitoring is provided in the wetwell and drywell by the CAMS. This monitoring function, when used during normal operation, determines when the primary containment is inert and nitrogen purging may be terminated. It also determines when primary containment is de-inerted and personnel re-enter procedures may be initiated.*

#### 6.2.5.6 Personnel Safety

The following standard supplement addresses the COL License Information Item in this subsection of the reference ABWR DCD.

A special maintenance procedure provides the requirements for controlling purged drywell entry. This procedure contains the following elements:

- (1) Inerting and de-inerting of the drywell is in conformance with applicable Technical Specifications.
- (2) Personnel access to the drywell is normally prohibited at all times when the drywell has an oxygen-deficient atmosphere, unless an emergency condition arises, in which case the procedure outlined in Subsection 6.2.5.6(8) should be followed.
- (3) The status of the drywell atmosphere is posted at the drywell entrance at all times, and the entrance locked, except when cleared for entry.
- (4) Suitable authorization, control and recording procedures are established and remain in effect throughout the entry process.

- (5) Prior to initial entry, the drywell is purged with air in accordance with operating procedure until drywell samples indicate that the following conditions are met:
  - (a) Oxygen: Greater than 16.5% content by volume.
  - (b) Hydrogen: Less than 14% of the lower limit of flammability, or a limit of 0.57% hydrogen by volume. (The lower flammability limit is 4.1% hydrogen content by volume.)
  - (c) Carbon Monoxide: Less than 100 ppm.
  - (d) Carbon Dioxide: Less than 5000 ppm.
  - (e) Airborne Activity: Less than applicable limits in 10 CFR 20, or equivalent.
- (6) During the purge, drywell atmosphere samples are drawn from a number of locations when the drywell oxygen analyzer indicates an oxygen concentration of 16.5% or greater. Samples are analyzed for oxygen, hydrogen, carbon monoxide, carbon dioxide and airborne activity. When the results of two successive samples taken at least one-half hour apart are found to be within the conditions in Subsection 6.2.5.6(5), initial entry may be authorized.
- (7) Criteria for entry are:
  - (a) The initial entry will require a minimum of two (2) persons.
  - (b) Initial entry will require, in addition to normal protective clothing and protective equipment consisting of self-contained breathing apparatus (such as Scott Air Pack), portable air sampling and monitoring equipment, and portable radiation survey meters.
  - (c) A means of communication shall be established.
- (8) Under certain conditions, the Plant General Manager (or his designee) may deem that an emergency condition exists which would justify drywell entry with an oxygen deficient atmosphere.
- (9) When it has been determined from the results of the initial entry survey and samples that the entire drywell atmosphere meets the required conditions, the drywell may be cleared for general access and the drywell status posted at the drywell entrance.

## **6.2.7 COL License Information**

### **6.2.7.1 Alternate Hydrogen Control**

The following standard supplement addresses COL License Information Item 6.2.

The NRC has revised 10 CFR 50.44 to amend its standards for combustible gas control in light-water-cooled power reactors. The amended rule eliminates the requirements for hydrogen recombiners and relaxes the requirements for hydrogen and oxygen monitoring. With the elimination of the requirement to provide hydrogen control equipment, the need to provide cost analysis for alternate control systems is also eliminated.

### **6.2.7.2 Administrative Control Maintaining Containment Isolation**

The following standard supplement addresses COL License Information Item 6.3.

The necessary controls for maintaining the primary containment boundary in accordance with Subsection 6.2.6.3.1 are in various plant operating procedures which control operation, testing and maintenance requirements for containment barriers. These include administrative procedures for controlling access, surveillance and maintenance procedures for controlling testing and restoration of containment components and operating procedures for controlling the routine operation of containment valves and components.

### **6.2.7.3 Suppression Pool Cleanliness**

The following standard supplement addresses COL License Information Item 6.4.

Subsection 6.2.1.7.1 provides a description of the operational program for Suppression Pool Cleanliness. This program will be implemented prior to Plant Startup as described in Table 13.4S-1 of Section 13.4S. The procedures that will implement this program will be complete and available for NRC review 60-days prior to startup testing (COM 6.2-1) .

### **6.2.7.4 Wetwell to Drywell Vacuum Breaker Protection**

The following standard supplement addresses COL License Information Item 6.5.

The vacuum breakers are installed horizontally and located in the wetwell gas space. There is one valve per penetration (through the pedestal wall) with the valves opening into the lower drywell. The location protects vacuum breaker valves from being subjected to the cyclic pressure loading during LOCA steam condensation period. The location of these valves, both axially and azimuthally, is shown in Figures 1.2-3c and 1.2-13k. A Vacuum Breaker Shield (consisting of a solid "V" shaped plate) is provided below each vacuum breaker to protect the valves from LOCA pool swell loads. The pool swell loads in the wetwell space, where the vacuum breaker assemblies are exposed, are discussed in FSAR Appendix 3B.

### **6.2.7.5 Containment Penetration Leakage Rate Test (Type B)**

The following standard supplement addresses COL License Information Item 6.5a.

Type B leakage rate tests are performed in conformance with 10 CFR 50 Appendix J for containment penetrations whose designs incorporate resilient seals, bellows, gaskets, or sealant compounds, airlocks and lock door seals, equipment and access hatch seals, and electrical canisters, and other such penetrations. The Containment Leakage Rate Program is described in Subsection 6.2.6.2.1.

### **6.2.8 References**

STD DEP 6.2-2

- 6.2-5 "Implementation of ABWR DCD Methodology using GOTHIC for STP 3 and 4 Containment Design Analyses." WCAP-17058, Westinghouse Electric Company, LLC, June 2009.
- 6.2-6 "Nuclear Maintenance Applications Center: Foreign Material Exclusion Guidelines", EPRI TR 1016315, Electric Power Research Institute, July 2008.
- 6.2-7 "Guidelines for Achieving Excellence in Foreign Materials Exclusion (FME)", INPO 07-008, Institute of Nuclear Power Operations, December 2007.

**Table 6.2-1 Containment Parameters**

<b>Design Parameter</b>	<b>Design Value</b>	<b>Calculated Value<sup>1</sup></b>
1. Drywell pressure	309.9 kPaG	<del>268.7 kPaG</del> <u>281.8 kPaG</u>
2. Drywell temperature	171.1°C	<del>470°C</del> <u>173.2°C<sup>2</sup></u>
3. Wetwell pressure	309.9 kPaG	<del>479.5</del> <u>217.2</u>
4. Wetwell temperature		
• Gas Space	<del>403.9°C</del> <u>104°C</u>	<del>98.9</del> <u>98.6°C</u>
• Suppression pool	<del>97.2</del> <u>100°C</u>	<del>96.9</del> <u>99.6°C</u>
5. Drywell-to-wetwell differential pressure	+172.6 kPaD -13.7 kPaD	<del>+109.8 kPaG</del> <u>+148.3 kPaD</u> <del>- 10.7 kPaG</del>

<sup>1</sup> Calculated values from Ref 6.2-5

<sup>2</sup> Calculated drywell maximum temperature exceeds design temperature for only 2 seconds. See discussion in Section 6.2.1.1.2.1.

**Table 6.2-2 Containment Parameters**

	<b>Drywell</b>	<b>Wetwell</b>
<b>A. Drywell and Wetwell</b>		
1. Internal Design Pressure (kPaG)	309.9	<del>309.96</del> <u>309.9</u>
3. Design Temperature (°C)	171.1	<del>403.9</del> <u>104</u>
<b>B. Vent System</b>		
5. Vent Loss Coefficient (Varies with number of vents open)		<del>2.5</del> <u>3.5 ‡</u>

‡ Provided in Section 6.1 of Reference 6.2-5.

**Table 6.2-2b Net Positive Suction Head (NPSH) Available to RHR Pumps**

<p>A. Suppression pool is at its minimum depth, El. -3740 mm.</p> <p>B. <del>Centerline of pump suction</del> <b>NPSH Reference level</b> is at El. -7200 mm*.</p> <p>C. Suppression pool water is at its maximum temperature for the given operating mode, 100°C.</p> <p>D. Pressure is atmospheric above the suppression pool.</p> <p>E. Minimum suction strainer area as committed to by Appendix 6C methods.</p> <p><math>NPSH_{available} = H_{ATM} + H_S - H_{VAP} - H_F(H_F + H_{ST})</math></p> <p>where:</p> <p><math>H_{ATM}</math> = Atmospheric head</p> <p><math>H_S</math> = Static head</p> <p><math>H_{VAP}</math> = Vapor pressure head</p> <p><math>H_F</math> = Maximum Frictional head <del>including strainer allowed</del> <b>excluding strainer frictional head</b></p> <p><math>H_{ST}</math> = Strainer frictional head</p> <p>Minimum Expected NPSH</p> <p>RHR Pump Runout is 1130 m<sup>3</sup>/h.</p> <p>Maximum suppression pool temperature is 100°C.</p> <p><math>H_{ATM} = 10.78m</math> <b>10.77m</b></p> <p><math>H_S = 3.46m</math></p> <p><math>H_{VAP} = 10.78m</math> <b>10.77m</b></p> <p><math>H_F = 0.71m</math></p> <p><math>NPSH_{available} = 10.78 + 3.46 - 10.78 - 0.71 = 2.75m</math> <b>10.77 + 3.46 - 10.77 - (H<sub>F</sub> + H<sub>ST</sub>) = 3.46 - (H<sub>F</sub> + H<sub>ST</sub>)</b></p> <p><math>NPSH_{required} = 2.4m</math> <b>2.0m</b></p> <p>Margin = <del>0.35m</del> <b>1.46 - (H<sub>F</sub> + H<sub>ST</sub>)</b> = NPSH available – NPSH required</p> <p>* <b>NPSH Reference level is 1m above the pump floor level</b></p> <p>** <b>The final system design will meet the required NPSH with adequate margin.</b></p>
--

**Table 6.2-2c Net Suction Head (NPSH) Available to HPCF Pumps**

<p>A. Suppression pool is at its minimum depth, El. -3740 mm.</p> <p>B. Centerline of pump suction <b><u>NPSH Reference level</u></b> is at El. -7200 mm*.</p> <p>C. Suppression pool water is at its maximum temperature for the given operating mode, 100°C.</p> <p>D. Pressure is atmospheric above the suppression pool.</p> <p>E. Minimum suction strainer area as committed to by Appendix 6C methods.</p> <p><math>NPSH_{available} = H_{ATM} + H_S - H_{VAP} - H_F(H_F + H_{ST})</math></p> <p>Where:</p> <p><math>H_{ATM}</math> = Atmospheric head</p> <p><math>H_S</math> = Static head</p> <p><math>H_{VAP}</math> = vapor pressure head</p> <p><math>H_F</math> = Maximum Frictional head <del>including strainer allowed</del> <b><u>excluding strainer frictional head</u></b></p> <p><math>H_{ST}</math> = Strainer frictional head</p> <p>Minimum Expected NPSH</p> <p>HPCF Pump Runout is 890 m<sup>3</sup>/h.</p> <p>Maximum suppression pool temperature is 100°C</p> <p><math>H_{ATM} = 10.78\text{m}</math> <b><u>10.77m</u></b></p> <p><math>H_S = 3.46\text{m}</math></p> <p><math>H_{VAP} = 10.78\text{m}</math> <b><u>10.77m</u></b></p> <p><math>H_F = 0.91\text{m}</math></p> <p><math>NPSH_{available} = 10.78 + 3.46 - 10.78 - 0.91 = 2.55\text{m}</math> <b><u>10.77 + 3.46 - 10.77 - (H<sub>F</sub> + H<sub>ST</sub>) = 3.46 - H<sub>F</sub> - H<sub>ST</sub></u></b></p> <p><math>NPSH_{required} = 2.2\text{m}</math> <b><u>1.7 m</u></b></p> <p>Margin = <del>0.35</del> <b><u>1.76 - (H<sub>F</sub> + H<sub>ST</sub>) = NPSH available - NPSH required</u></b></p> <p><b><u>*NPSH Reference level is 1m above the pump floor level</u></b></p> <p><b><u>** The find system design will meet the required NPSH with adequate margin.</u></b></p>
---



**Table 6.2-5 Reactor Coolant Pressure Boundary (RCPB) Influent Lines Penetrating Drywell**

Drywell	Inside Drywell	Outside Drywell
<b>Influent Line</b>		
5. Reactor water cleanup, reactor vessel head spray	<del>MOV</del> CV	MOV
6. Recirculating internal pump seal purge water supply	<del>CV</del> N/A	<del>CV</del> EFCV

Note:

EFCV - Excess flow check valve

**Table 6.2-6 Reactor Coolant Pressure Boundary (RCPB) Effluent Lines Penetrating Drywell**

<u>Inside Drywell</u>	<u>Outside Drywell</u>	<u>Drywell</u>
<u>Effluent Line</u>		
1. Main steam	GOVAOV	GOV

Note:

AOV-Air operated valve. Air to open, and Air and/or spring to close.

**Table 6.2-7 Containment Isolation Valve Information Reactor Recirculation System RIP Purge**

<u>Valve No.</u>	<u>B31-F008A-H/J/K</u>
<u>Line Size</u>	<u>15A20A</u>

**Table 6.2-7 Containment Isolation Valve Information\***

<u>MPL</u>	<u>System</u>	<u>Page</u>
<i>T49</i>	<i>Flammability Control</i>	<i>Page 6.2-155 and 6.2-156</i>

**Table 6.2-7 Containment Isolation Valve Information Standby Liquid Control System**

<u>Valve No.</u>	<u>C41-F008</u>	<u>C41-F006A</u>	<u>C41-F006B</u>
Type C Leak Test	No (w) Yes	No (w) Yes	No (w) Yes

**Table 6.2-7 Containment Isolation Valve Information (Continued)**  
**Containment Atmospheric Monitoring**

<b>Valve No.</b>	<b>D23-F001A/B</b>	<b>D23-F004A/B</b>	<b>D23-F005A/B</b>	<b>D23-F006A/B</b>	<b>D23-F007A/B</b>	<b>D23-F008A/B</b>
Normal Position	Open	Close/Open	Close/Open	Close/Open	Close/Open	Close/Open
Containment Isolation Signal(c)	N/A RM	N/A RM	N/A RM	N/A RM	N/A RM	N/A RM

**Table 6.2-7 Containment Isolation Valve Information (Continued)**  
**Residual Heat Removal System Wetwell Spray**

Valve No.	E11-F019B	E11-F019C
Post-accident Position	Close/Open	Close/Open
Closure Time (s)	<del>20</del> <u>3420</u>	<del>20</del> <u>3420</u>

**Residual Heat Removal System Drywell Spray**

Valve No.	E11-F017B	E11-F018B	E11-F017C	E11-F018C
Post-accident Position	Close/Open	Close/Open	Close/Open	Close/Open

**Residual Heat Removal System Minimum Flow Line**

Valve No.	E11-F021A	E11-F021B	E11-F021C
Shutdown Position	<del>Open</del> Close	<del>Open</del> Close	<del>Open</del> Close

**Residual Heat Removal System S/P Cooling**

Valve No.	E11-F008A		E11-F008B		E11-F008C
Line Size	<del>200A</del> 250A		<del>200A</del> 250A		<del>200A</del> 250A

**Residual Heat Removal System S/P Suction (LPFL)**

Valve No.	E11-F001A	E11-F001B	E11-F001C
Post-accident Position	<del>Close</del> Open	<del>Close</del> Open	<del>Close</del> Open

**Residual Heat Removal System Inboard Shutdown Cooling**

Valve No.	E11-F010A	E11-F010B	E11-F010C
Shutdown Position	<del>Close</del> Open/Close	<del>Close</del> Open/Close	<del>Close</del> Open/Close

**Containment Isolation Valve Information**

**Residual Heat Removal System Outboard Shutdown Cooling**

Valve No.	E11-F011A	E11-F011B	E11-F011C
Shutdown Position	<del>Close</del> Open/Close	<del>Close</del> Open/Close	<del>Close</del> Open/Close

**Table 6.2-7 Containment Isolation Valve Information (Continued)**  
**Residual Heat Removal System Injection and Testable Check**

Valve No.	E11-F005B	E11-F006B	E11-F005C	E11-F006C
Post-accident Position	Close/Open	Close/Open	Close/Open	Close/Open

**High Pressure Core Flooder System S\I P Suction**

Valve No.	E22-F006B	E22-F006C
Post-Accident Position	Close/Open	Close/Open
Containment Isolation Signal (c)	N/A RM	N/A RM

**High Pressure Core Flooder System Test and Minimum Flow**

Valve No.	E22-F009B	E22-F010B	E22-F009C	E22-F010C
Containment Isolation Signal (c)	N/A RM	N/A RM	N/A RM	N/A RM

**High Pressure Core Flooder System Injection**

Valve No.	E22-F003B	E22-F004B	E22-F003C	E22-F004C
Post-Accident Position	Close/Open	Close/Open	Close/Open	Close/Open

**Nuclear Boiler System Main Steam Lines A, B, C and D**

Valve No.	B21-F008A/B C/D	B21-F009A/B C/D
ESF	Yes No	Yes No
Type C Leak Test	Yes(e)(t)	Yes(e)(t)
Primary Actuation	N <sub>2</sub> to open N <sub>2</sub> and/or Spring to close	N <sub>2</sub> Air to open N <sub>2</sub> Air and/or Spring to close
Containment Isolation Signal (c)	C, D, E, F, H, N, BB, RM	C, D, E, F, H, N, BB, RM

**Table 6.2-7 Containment Isolation Valve Information (Continued)**  
**Nuclear Boiler System Main Steam Line Drains**

Valve No.	B21-F011	B21-F012
ESF	<del>Yes</del> No	<del>Yes</del> No
Type C Leak Test	Yes(e)( <del>t</del> )	Yes(e)( <del>t</del> )
Normal Position	<del>Open</del> / <del>Close</del> Open	<del>Open</del> / <del>Close</del> Open
Containment Isolation Signal (c)	C, <del>D</del> , E, F, H, N, BB, RM	C, <del>D</del> , E, F, H, N, BB, RM
Power Source (Div)	<del>#</del> - <del>I</del> <u>II</u>	<del>I</del> - <del>#</del> <u>I</u>

**Nuclear Boiler System Feedwater Line A and B**

Valve No.	B21-F004A/B	B21-F003A/B
Type C Leak Test	Yes( <del>t</del> )	Yes ( <del>t</del> )
Shutdown Position	<del>Close</del> Open/Close	<del>Close</del> Open/Close
Post-Accident Position	<del>Close</del> Open/Close	<del>Close</del> Open/Close

**Reactor Core Isolation Cooling System Steam Supply**

Valve No.	E51-F035	E51-F048	E51-F036
Type C Leak Test	Yes(e) ( <del>t</del> )	Yes(e) ( <del>t</del> )	Yes ( <del>t</del> )
Post-Accident Position	<del>Close</del> Open/Close	<del>Close</del> Open/Close	<del>Close</del> Open/Close

**Reactor Core Isolation Cooling System S/P Suction**

Valve No.	E51-F006
Post-Accident Position	<del>Close</del> Close/Open

**Reactor Core Isolation Cooling System Turbine Exhaust**

Valve No.	E51-F039	E51-F038
Type C Leak Test	Yes(e) ( <del>t</del> )	Yes( <del>t</del> )
Shutdown Position	Open	<del>Open</del> Close

**Table 6.2-7 Containment Isolation Valve Information (Continued)**  
 Reactor Core Isolation Cooling System Vacuum Pump Discharge

<del>Valve No.</del>	<del>E51-F047</del>	<del>E51-F046</del>
Tier 2 Figure	5.4-8 (Sheet 1)	5.4-8 (Sheet 1)
Applicable Basis	GDC-56	GDC-56
Fluid	Steam	Steam
Line Size	50A	50A
ESF	Yes	Yes
Leakage Class	(a)	(a)
Location	Ø	Ø
Type-C Leak Test	No(I)	No(I)
Valve Type	Gate	Check
Operator	Motor	Self
Primary Actuation	Electrical	N/A
Secondary Actuation	Manual	N/A
Normal Position	Open	Close
Shutdown Position	Open	Open
Post-Accident Position	Close	Close
Power-Fail Position	As is	N/A
Containment Isolation Signal (c)	RM	N/A
Closure Time (s)	<10	Instantaneous
Power Source (Div)	†	N/A
See page 6.2-167 for notes		

**Table 6.2-7 Containment Isolation Valve Information (Continued)**  
**Atmospheric Control System**

Valve No.	T31-F001	T31-F002	T31-F003	T31-F004	T31-F005	T31-F006	T31-F007
Line Size	<del>550A</del> <del>500A550A</del>	550A <del>500A550A</del>	550A <del>500A550A</del>	550A <del>500A550A</del>	50A	550A <del>500A550A</del>	250A
Containment Isolation Signal (c)	A, K, XX, YY, RM	A, K, XX, YY, RM	A, K, XX, YY, RM	A, K, XX, YY, RM	A, K, XX, YY, RM	A, K, XX, YY, RM	RM

**Atmospheric Control System**

Valve No.	T31-F008	T31-F009	T31-F025	T31-F039	T31-F040	T31-F041
Line Size	550A <del>500A550</del>	550A <del>500A550A</del>	400A	50A	50A	50A
Leakage Class	(b) (a)	(b) (a)	(b) (a)	(b) (a)	(b) (a)	(b) (a)
Type C Leak Test	Yes (b)	Yes (b)	Yes (b)	Yes (b)	Yes(e)	Yes(e)
Containment Isolation Signal (c)	A, K, XX, YY, RM	A, K, XX, YY, RM	A, K, XX, YY, RM	A, K, XX, YY, RM	A, K, XX, YY, RM	A, K, XX, YY, RM
Closure Time (s)	<20	<20 15	<20	<15	<15	<15

**Atmospheric Control System**

Valve No.	T31-F731	T31-F033A/B F733A/B	T31-F035A-D F735A-D	T31-F010	T31-F011
Line Size	20A	20A	20A	250A	550A <del>500A550A</del>
Containment Isolation Signal (c)	RM	RM	RM	RM	A, K, XX, YY, RM

**Atmospheric Control System**

Valve No.	T31-F805A/B	T31-D001	T31-D002
Type C Leak Test	No(m)	No(P) (p)	No(P) (p)



**Table 6.2-7 Containment Isolation Valve Information (Continued)**  
**Flammability Control System**

<b>Valve No.</b>	<b>T49-F001C</b>	<b>T49-F001B</b>	<b>T49-F002A</b>	<b>T49-F002E</b>
Tier 2 Figure	6.2-40 (Sheet 2)	6.2-40 (Sheet 1)	6.2-40 (Sheet 1)	6.2-40 (Sheet 2)
Applicable Basis	GDC-56	GDC-56	GDC-56	GDC-56
Fluid	DW Atmosphere	DW Atmosphere	DW Atmosphere	DW Atmosphere
Line Size	100A	100A	100A	100A
ESF	Yes	Yes	Yes	Yes
Leakage Class	(a)	(a)	(a)	(a)
Location	Ø	Ø	Ø	Ø
Type C Leak Test	No(u)	No(u)	No(u)	No(u)
Valve Type	Gate	Gate	Gate	Gate
Operator	Motor	Motor	Pneumatic	Pneumatic
Primary Actuation	Electrical	Electrical	Electrical	Electrical
Secondary Actuation	Manual	Manual	Manual	Manual
Normal Position	Close	Close	Close	Close
Shutdown Position	Close	Close	Close	Close
Post-Accident Position	Open	Open	Open	Open
Power-Fail Position	As-is	As-is	As-is	As-is
Containment Isolation-Signal(e)	A,K	A,K	A,K	A,K
Closure Time (s)	<30	<30	<30	<30
Power Source (Div)	III	II	I, III	I, II
See page 6.2-167 for notes				

**Table 6.2-7 Containment Isolation Valve Information (Continued)**  
**Flammability Control System**

<del>Valve No.</del>	<del>T49-F006A</del>	<del>T49-F006E</del>	<del>T49-F007C</del>	<del>T49-F007B</del>
<del>Tier 2 Figure</del>	<del>6.2-40 (Sheet 1)</del>	<del>6.2-40 (Sheet 2)</del>	<del>6.2-40 (Sheet 2)</del>	<del>6.2-40 Sheet 1)</del>
<del>Applicable Basis</del>	<del>GDC-56</del>	<del>GDC-56</del>	<del>GDC-56</del>	<del>GDC-56</del>
<del>Fluid</del>	<del>WW</del>	<del>WW</del>	<del>WW</del>	<del>WW</del>
	<del>Atmosphere</del>	<del>Atmosphere</del>	<del>Atmosphere</del>	<del>Atmosphere</del>
<del>Line Size</del>	<del>150A</del>	<del>150A</del>	<del>150A</del>	<del>150A</del>
<del>ESF</del>	<del>Yes</del>	<del>Yes</del>	<del>Yes</del>	<del>Yes</del>
<del>Leakage Class</del>	<del>(a)</del>	<del>(a)</del>	<del>(a)</del>	<del>(a)</del>
<del>Location</del>	<del>Q</del>	<del>Q</del>	<del>Q</del>	<del>Q</del>
<del>Type C Leak Test</del>	<del>No(u)</del>	<del>No(u)</del>	<del>No(u)</del>	<del>No(u)</del>
<del>Valve Type</del>	<del>Gate</del>	<del>Gate</del>	<del>Gate</del>	<del>Gate</del>
<del>Operator</del>	<del>Pneumatic</del>	<del>Pneumatic</del>	<del>Motor</del>	<del>Motor</del>
<del>Primary Actuation</del>	<del>Electrical</del>	<del>Electrical</del>	<del>Electrical</del>	<del>Electrical</del>
<del>Secondary Actuation</del>	<del>Manual</del>	<del>Manual</del>	<del>Manual</del>	<del>Manual</del>
<del>Normal Position</del>	<del>Close</del>	<del>Close</del>	<del>Close</del>	<del>Close</del>
<del>Shutdown Position</del>	<del>Close</del>	<del>Close</del>	<del>Close</del>	<del>Close</del>
<del>Post-Accident Position</del>	<del>Open</del>	<del>Open</del>	<del>Open</del>	<del>Open</del>
<del>Power Fail Position</del>	<del>As is</del>	<del>As is</del>	<del>As is</del>	<del>As is</del>
<del>Containment Isolation Signal(e)</del>	<del>A,K</del>	<del>A,K</del>	<del>A,K</del>	<del>A,K</del>
<del>Closure Time (s)</del>	<del>&lt;30</del>	<del>&lt;30</del>	<del>&lt;30</del>	<del>&lt;30</del>
<del>Power Source (Div)</del>	<del>I, III</del>	<del>I, II</del>	<del>III</del>	<del>II</del>
<del>See page 6.2-167 for notes</del>				

**Table 6.2-7 Containment Isolation Valve Information (Continued)**  
**Reactor Water Cleanup System**

<b>Valve No.</b>	<b>G31-F071</b>	<b>G31-F072</b>
<i>Tier 2 Figure</i>	5.4-12 (Sheet 1)	5.4-12 (Sheet 1)
<i>Applicable Basis</i>	GDC55	GDC55
<i>Fluid</i>	RPV H <sub>2</sub> O	RPV H <sub>2</sub> O
<i>Line Size</i>	20A	20A
<i>ESF</i>	No	No
<i>Leakage Class</i>	(a)	(a)
<i>Location</i>	I	O
<i>Type C leak Test</i>	Yes	Yes
<i>Valve Type</i>	Globe	Globe
<i>Operator</i>	Pneumatic	Pneumatic
<i>Primary Actuation</i>	Electrical	Electrical
<i>Secondary Actuation</i>	Manual	Manual
<i>Normal Position</i>	Close	Close
<i>Shutdown Position</i>	Close	Close
<i>Post-accident Position</i>	Close	Close
<i>Power Fail Position</i>	Close	Close
<i>Containment Isolation Signal(c)</i>	C,E,F,H,N,BB,RM	C,E,F,H,N,BB,RM
<i>Closure Time(s)</i>	<15	<15
<i>Power Source (Div)</i>	II	I
<i>See page 6.2-167 for notes</i>		

**Table 6.2-7 Containment Isolation Valve Information  
Suppression Pool Cleanup System**

Valve No.	G51-F001	G51-F002	G51-F006	G51-F007
Applicable Basis	GDC- <del>56-57</del> <u>56</u>	GDC- <del>56-57</del> <u>56</u>	GDC- <del>56-57</del> <u>56</u>	GDC- <del>56-57</del> <u>56</u>
ESF	Yes-No	Yes-No	Yes-No	Yes-No
Type C Leak Test	No( <del>p</del> )( <del>r</del> )( <b>q</b> )	No( <del>p</del> )( <del>r</del> )( <b>q</b> )	No( <del>q</del> )( <b>r</b> )	No( <del>q</del> )( <b>r</b> )
Shutdown Position	Open /Close	Open /Close	Open /Close	Open /Close
Post-Accident Position	Close	Close	N/A-Close	Close
Containment Isolation Signal(c)	A,K, <b>X</b> ,RM	A,K, <b>X</b> ,RM	A,K, <b>X</b> ,RM	A,K, <b>X</b> ,RM
Closure Time (s)	< <del>30-45</del> <u>&lt;30</u>	< <del>30-45</del> <u>&lt;30</u>	Inst.	< <del>30-60</del> <u>&lt;30</u>

**Reactor Building Cooling Water System**

Valve No.	P21-F075A /F076A	P21-F081A /F080A	P21-F075B /F076B	P21-F081B /F080B
Applicable Basis	GDC <del>57 56</del>	GDC <del>57 56</del>	GDC <del>57 56</del>	GDC <del>57 56</del>
Leakage Class	( <del>b</del> )( a )	( <del>b</del> )( a )	( <del>b</del> )( a )	( <del>b</del> )( a )
Type C Leak Test	No( <del>s</del> )( t )	No( <del>s</del> )( t )	No( <del>s</del> )( t )	No( <del>s</del> )( t )
Post-Accident Position	Close/Open	Close/Open	Close/Open	Close/Open

**HVAC Normal Cooling Water System**

Valve No.	P24-F053	P24-F054	P24-F0142	<u>P24-F0141</u>
Applicable Basis	GDC <del>57 56</del>	GDC <del>57 56</del>	GDC <del>57 56</del>	GDC <del>57 56</del>
Leakage Class	( <del>b</del> )( a )	( <del>b</del> )( a )	( <del>b</del> )( a )	( <del>b</del> )( a )
Containment Isolation Signal(c)	CX,K, <b>RM</b>	N/A	CX,K, <b>RM</b>	CX,K, <b>RM</b>
Power Source (Div)	I	N/A	<del>I-#I</del>	<del>##-I II</del>

**Table 6.2-7 Containment Isolation Valve Information (Continued)  
Service Air System**

<b>Valve No.</b>	<b>P51-F131</b>	<b>P52-F132</b>
Applicable Basis	<u>GDC 57 56</u>	<u>GDC 5756</u>
See page 6.2-167 for notes		

**Instrument Air System**

<b>Valve No.</b>	<b>P52-F276</b>	<b>P52-F277</b>
Applicable Basis	<u>GDC 57 56</u>	<u>GDC 57 56</u>

**High Pressure Nitrogen Gas Supply System**

<b>Valve No.</b>	<b>P54-F007A/F008A</b>	<b>P54-F007B/F008B</b>	<b>P54-F200/F209</b>
Applicable Basis	<u>GDC 57 56</u>	<u>GDC 57 56</u>	<u>GDC 57 56</u>
Leakage Class	<del>(b)</del> ( a )	<del>(b)</del> ( a )	<del>(b)</del> ( a )
Type C Leak Test	No( <del>†</del> ) (s)	No( <del>†</del> ) (s)	No( <del>†</del> ) (s)
Containment Isolation Signal(c)	<del>GG(Y)N/A</del>	<del>GG(Y)N/A</del>	<del>GG(Y)N/A</del>

**Leak Detection & Isolation System**

<b>Valve No.</b>	<b>E31-F002</b>	<b>E31-F003</b>	<b>E31-F004</b>	<b>E31-F005</b>	<b>E31-F009/ F010</b>
Type C Leak Test	Yes(e)	Yes(e)	Yes(e)	Yes(e)	Yes(e) ( <del>†</del> )
Containment Isolation Signal(c)	B,K,RM	B,K,RM	B,K,RM	B,K,RM	N/A

**Table 6.2-7 Containment Isolation Valve Information (*Continued*)  
Radwaste System**

<b>Valve No.</b>	<b>K17-F003</b>	<b>K17-F004</b>	<b>K17-F103</b>	<b>K17-F104</b>
Applicable Basis	GDC <del>57</del> <b>56</b>	GDC <del>57</del> <b>56</b>	GDC <del>57</del> <b>56</b>	GDC <del>57</del> <b>56</b>
Type C Leak Test	No( <del>v</del> ) (w)	No( <del>v</del> ) (w)	No( <del>v</del> ) (w)	No( <del>v</del> ) (w)
Containment Isolation Signal(c)	A/FF , <b>K,RM</b>	FF, <b>A,K,RM</b>	A/FF , <b>K,RM</b>	FF, <b>A,K,RM</b>

Table 6.2-7 Breathing Air System

Valve No.	<del>P56-F001</del> P81-F251	<del>P56-F002</del> P81-F252
Tier 2 Figure	9.3-10	9.3-10
Applicable Basis	GDC 56	GDC 56
Fluid	Air	Air
Line Size	40A	40A
ESF	No	No
Leakage Class	<del>(a)</del> (b)	<del>(a)</del> (b)
Location	O	I
Type C Leak Test	Yes	Yes
Valve Type	Globe	<del>Check</del> Globe
Operator	<del>Manual</del> HW	<del>None</del> HW
Primary Actuation	<del>Electrical</del> Manual	<del>Electrical</del> Manual
Secondary Actuation	<del>Manual</del> NA	<del>Manual</del> NA
Normal Position	Close	Close
Shutdown Position	Close/Open	Close/Open
Post-Accident Position	Close	Close
Power Fail Position	<del>As-is</del> NA	<del>As-is</del> NA
Containment Isolation Signal(c)	NA	NA
Closure Time (s)	NA	NA
Power Source (Div)	NA	NA
<u>See page 6.2-167 for notes</u>		

**Table 6.2-7 Containment Isolation Valve Information (Continued)  
Neutron Monitoring System**

Valve No.	C51-J004A	C51-J004B	C51-J004C	C51-J011
Tier 2 Figure	7.6-2 (Sheet 3)	7.6-2 (Sheet 3)	7.6-2 (Sheet 3)	7.6-2 (Sheet 3)
Applicable Basis	GDC57	GDC57	GDC57	GDC57
Fluid	N <sub>2</sub>	N <sub>2</sub>	N <sub>2</sub>	N <sub>2</sub>
Line Size	OD15	OD15	OD15	20A
ESF	No	No	No	No
Leakage Class	(a)	(a)	(a)	(a)
Location	O	O	O	O
Type C leak Test	Yes	Yes	Yes	Yes
Valve Type	Ball	Ball	Ball	Globe
Operator	Motor	Motor	Motor	Solenoid
Primary Actuation	Electrical	Electrical	Electrical	Electrical
Secondary Actuation	N/A	N/A	N/A	N/A
Normal Position	Close	Close	Close	Close
Shutdown Position	Close	Close	Close	Close
Post-accident Position	Close	Close	Close	Close
Power Fail Position	Close	Close	Close	Close
Containment Isolation Signal(c)	A,K	A,K	A,K	A,K
Closure Time(s)	<3	<3	<3	Instantaneous
Power Source (Div)	N/A	N/A	N/A	N/A
See page 6.2-167 for notes				

## Notes:

## (c) Isolation Signal Codes

<u>Signal</u>	<u>Description</u>
<u>D</u>	<u>High radiation – main steamline.</u>
<u>M</u>	<u>Line leak in RHR shutdown.</u>
<u>I</u>	<u>High pressure RCIC turbine exhaust diaphragm</u>

- (v) ~~Flammability control is a closed loop, safety grade system required to be functional post accident. Whatever is leaking (if any) is returned to the primary containment. In addition, during ILRT, these valves are opened and the lines are subjected to Type A test.~~ Not Used



Table 6.2-8 Primary Containment Penetration List\*

Penetration Number	Name	Elevation (mm)	Azimuth (deg)	Offset (mm)	Diameter (mm)	Barrier Type	Testing††
X-5	L/D Personnel Hatch	-650	0	0	<del>2400/5000</del> 4300	Door	B
X-6	L/D Equipment Hatch	-900	180	0	<del>2400/5000</del> 4300	Door	B
X-10A	Mainsteam Line	16300	0	1400	1200	Valve	A-C
X-10B	Mainsteam Line	16300	0	4200	1200	Valve	A-C
X-10C	Mainsteam Line	16300	0	-4200	1200	Valve	A-C
X-10D	Mainsteam Line	16300	0	-1400	1200	Valve	A-C
X-11	Mainsteam Drain	13650	0	5200	500	Valve	A-C
X-12A	Feedwater Line	13810	0	2800	950	Valve	A-C
X-12B	Feedwater Line	13810	0	-2800	950	Valve	A-C
X-22	Borated Water Injection	15250	275	0	450	Valve	A
X-30B	Drywell Spray	14680	260	-3400	200	Valve	A
X-30C	Drywell Spray	14680	100	3400	200	Valve	A
X-31A	HPCF (B)	14630	260	0	600	Valve	A
X-31B	HPCF (C)	14630	100	0	600	Valve	A
X-32A	LPFL (B) RHR (B)	14610	260	-2000	650	Valve	A
X-32B	LPFL (C) RHR (C)	14610	100	-1800	650	Valve	A
X-33A	RHR Suction (A)	14550	80	-800	750	Valve	A
X-33B	RHR Suction (B)	14550	260	1800	750	Valve	A
X-33C	RHR Suction (C)	14550	100	2000	750	Valve	A
X-37	RCIC Turbine Steam	<del>44450</del> 14414	80	1200	550	Valve	A-C
X-38	RPV Head Spray	14450	310	1500	550	Valve	A-C
X-50	CUW Pump Feed	14480	310	0	600	Valve	A-C
X-60	MUWP Suction	13500	290	0	200	Valve	A-C
X-61	RCW Suction (A)	<del>43500</del> 13700	45	-3000	200	Valve	A
X-62	RCW Return (A)	<del>43500</del> 13700	45	-2000	200	Valve	A
X-63	RCW Suction (B)	13500	225	3400	200	Valve	A
X-64	RCW Return (B)	13500	225	2400	200	Valve	A
X-65	HNCW Suction	13500	225	250	350	Valve	A-C
X-66	HNCW Return	13500	225	1400	350	Valve	A-C
X-69	SA	19000	42	0	90	Valve	A-C

Table 6.2-8 Primary Containment Penetration List\*

Penetration Number	Name	Elevation (mm)	Azimuth (deg)	Offset (mm)	Diameter (mm)	Barrier Type	Testing†‡
X-70	IA	<del>9000</del> 19000	46	0	200	Valve	<del>A-C</del>
X-71A	ADS Accumulator (A)	19000	50	0	200	Valve	A
X-71B	ADS Accumulator (B)	19000	296.5	1000	200	Valve	A
X-72	Relief Valve Accumulator	19000	296.5	2000	200	Valve	A
X-80	Drywell Purge Suction	13700	68	0	<del>550</del> <del>600</del> 550	Valve	<del>A-C</del>
X-81	Drywell Purge Exhaust	19000	216	0	<del>550</del> <del>600</del> 550	Valve	<del>A-C</del>
X-82	<b>FCS Suction-Spare</b>	14850	225	-600	150	Welded Cap	A <del>C</del> A
X-90	Spare	20100	<del>46</del> 50	0	400	Welded Cap	<del>C</del> A
X-91	Spare	20100	296.5	1000	<del>400</del> 300	Welded Cap	<del>C</del> A
X-92	Spare	<del>16400</del> 14700	<del>45</del> <del>55</del> 45	<del>12700</del> -1000	<del>400</del> 300	Welded Cap	<del>C</del> A
X-93	Spare	14700	135	-500	400	Welded Cap	<del>C</del> A
X-94	Spare	16400	300	-500	400	Welded Cap	<del>C</del> A
X-95	Spare	9400	45	-400	400	Welded Cap	<del>C</del> A
X-100A	RIP Power	<del>13500</del> <del>16400</del> 13500	<del>55</del> <del>54</del> 55	-1100	450	O-ring	B
X-100B	RIP Power	<del>13500</del> <del>16400</del> 13500	180	<del>2650</del> 2725	450	O-ring	B
X-100C	RIP Power	<del>13500</del> <del>16400</del> 13500	180	-6550	<del>450</del> 300	O-ring	B
X-100D	RIP Power	<del>13500</del> <del>16400</del> 13500	280	0	450	O-ring	B
X-100E	RIP Power	<del>13500</del> <del>16400</del> 13500	<del>180</del> <del>284</del> 180	<del>2650</del> -2725	450	O-ring	B
X-100F	RIP Power	<del>16400</del> 13500	<del>54</del> 280	<del>2800</del> 1350	450	O-ring	B
X-101A	LP Power	16400	<del>45</del> <del>54</del> 45	0	<del>300</del> 450	O-ring	B
X-101B	LP Power	16400	180	<del>50</del> 125	<del>300</del> 450	O-ring	B
X101C	LP Power	<del>16400</del>	<del>180</del>	<del>1360</del> -1425	300	O-ring	B
X-101D	FMCRD Power	<del>19000</del> <del>20400</del> 19000	<del>279.5</del> 279 81	<del>1350</del> -1350	300	O-ring	B

Table 6.2-8 Primary Containment Penetration List\* (Continued)

Penetration Number	Name	Elevation (mm)	Azimuth (deg)	Offset (mm)	Diameter (mm)	Barrier Type	Testing†‡
X-101E	FMCRD Power	<del>49000</del> <del>20100</del> <b>19000</b>	<del>84</del> <b>260.5</b>	-1350	300	O-ring	B
X-101F	FMCRD Power	<del>49000</del>	<u>279.5</u> <del>260.5</del>	<u>1350</u> <del>-1350</del>	300	O-ring	B
X-101G	FMCRD Power	<del>49000</del> <b>19000</b>	99	<del>-1350</del> <u>1350</u>	300	O-ring	B
X-101J	LP Power	<del>46700</del>	<u>180</u>	5250	300	O-ring	B
X-101K	LP Power	<del>46400</del>	<u>45</u>	3900	300	O-ring	B
X-102A	I & C	16400	<del>45</del> <b>5445</b>	-1350	300	O-ring	B
X-102B	I & C	16400	180	<del>4350</del> <u>1425</u>	<del>300</del> <b>450</b>	O-ring	B
X-102C	I & C	<del>16400</del> <del>7630</del> <b>16400</b>	<del>180</del> <b>220180</b>	<del>-2650</del> <del>-2725</del>	300	O-ring	B
X-102D	I & C	<del>16400</del> <del>13500</del> <b>16100</b>	<del>280</del> <b>54280</b>	<u>0</u> <b>1350</b>	300	O-ring	B
X-102E	I & C	<del>49000</del> <del>13500</del> <b>19000</b>	99 <del>48099</del>	-1350	300	O-ring	B
X-102F	I & C	<del>49000</del> <del>13500</del> <b>19000</b>	273.5 <del>480</del> <b>279.5</b>	-1350	300	O-ring	B
X-102G	I & C	13500	<del>180</del> <b>284180</b>	<del>-1350</del> <del>-1175</del>	300	O-ring	B
X102-H	I & C	13500	<u>180</u>	<del>-5250</del>	300	O-ring	B
X102-J	I & C	13500	<u>55</u>	1100	300	O-ring	B
X-103A	I & C	<del>16400</del> <del>6500</del> See Note 1	<del>45</del> <b>32340.5</b>	<del>-13500</del>	<del>300</del> <b>150</b>	O-ring	B
X-103B	I & C	<del>16400</del> <del>6500</del> See Note 1	<del>180</del> <b>306211</b>	<u>500</u>	<del>300</del> <b>150</b>	O-ring	B
X-103C	I & C	<del>16400</del> <del>7630</del> See Note 1	<del>180</del> <b>243134</b>	<del>-5250</del>	<del>300</del> <b>150</b>	O-ring	B
X-103D	I & C	<del>16400</del> <del>7630</del> See Note 1	<del>180</del> <del>138</del> <b>295</b>	<del>2650</del> <b>5600</b>	<del>300</del> <b>150</b>	O-ring	B
X-103E	I & C	<del>16400</del> <del>7630</del> See Note 1	<del>45</del> <del>150</del> <b>211</b>	<del>2700</del> <b>1350</b>	300	O-ring	B
X-104A	FMCRD Position Indicator	<del>49000</del> <del>20100</del> <b>19000</b>	81	0	300	O-ring	B
X-104B	FMCRD Position Indicator	<del>49000</del> <del>20100</del> <b>19000</b>	260.5	0	300	O-ring	B
X-104C	FMCRD Position Indicator	20100	99	<u>0</u> <b>1350</b>	<del>300</del> <b>450</b>	O-ring	B

Table 6.2-8 Primary Containment Penetration List\* (Continued)

Penetration Number	Name	Elevation (mm)	Azimuth (deg)	Offset (mm)	Diameter (mm)	Barrier Type	Testing††
X-104D	FMCRD Position Indicator	20100	279.5	<del>0</del> 1350	<del>300</del> 450	O-ring	B
X-104E	FMCRD Position Indicator	<del>19000</del> <del>20100</del> 19000	<del>99</del> 81	<del>0</del> 1350	300	O-ring	B
X-104F	FMCRD Position Indicator	<del>19000</del> <del>20100</del> 19000	260.5	1350	<del>300</del> 450	O-ring	B
X-104G	FMCRD Position Indicator	<del>19000</del> <del>20100</del> 19000	<del>84</del> 99	<del>1350</del>	300	O-ring	B
X-104H	FMCRD Position Indicator	<del>19000</del> <del>20100</del> 19000	279.5	0	<del>300</del> 450	O-ring	B
X-105A	Neutron Detection	<del>20100</del> <del>19000</del> 20100	81	<del>1350</del> <del>0</del> 1350	<del>300</del> 450	O-ring	B
X-105B	Neutron Detection	<del>20100</del> <del>19000</del> 20100	260.5	<del>1350</del> <del>1300</del> 1350	<del>300</del> 450	O-ring	B
X-105C	Neutron Detection	<del>20100</del> <del>19000</del> 20100	99	<del>5250</del> <del>0</del> <del>1350</del>	<del>300</del> 450	O-ring	B
X-105D	Neutron Detection	<del>20100</del> <del>19000</del> 20100	279.5	<del>1350</del> <del>1300</del> <del>1350</del>	<del>300</del> 450	O-ring	B
<del>X-105E</del>	<del>Neutron Detection</del>	<del>19000</del>	<del>81</del>	<del>1300</del>	<del>450</del>	<del>O-ring</del>	<del>B</del>
<del>X-105F</del>	<del>Neutron Detection</del>	<del>19000</del>	<del>260.5</del>	<del>0</del>	<del>450</del>	<del>O-ring</del>	<del>B</del>
<del>X-105G</del>	<del>Neutron Detection</del>	<del>19000</del>	<del>99</del>	<del>1300</del>	<del>450</del>	<del>O-ring</del>	<del>B</del>
<del>X-105H</del>	<del>Neutron Detection</del>	<del>19000</del>	<del>279.5</del>	<del>0</del>	<del>450</del>	<del>O-ring</del>	<del>B</del>
X-106A	Div I Instrumentation	<del>13500</del> 16400	<del>54</del> 45	<del>1370</del> 1350	300	O-ring	B
X-106B	Div II Instrumentation	13500	180	<del>1457</del> 125	300	O-ring	B
X-106C	Div III Instrumentation	<del>13500</del> 16400	180	<del>1457</del> <del>6200</del>	300	O-ring	B
X-106D	Div IV Instrumentation	<del>13500</del> 16100	<del>28</del> 280	<del>13700</del>	300	O-ring	B
X-106F	Div NON Instrumentation	16400	180	2725	300	O-ring	B
X-106G	Div NON Instrumentation	16400	45	2700	300	O-ring	B
X-106H	Div NON Instrumentation	14700	55	1000	300	O-ring	B
X-106J	Div NON Instrumentation	20100	260.5	-1350	300	O-ring	B

Table 6.2-8 Primary Containment Penetration List\* (Continued)

Penetration Number	Name	Elevation (mm)	Azimuth (deg)	Offset (mm)	Diameter (mm)	Barrier Type	Testing††
X-107A	Group B Instr	<del>43500</del> 16400	<del>284</del> 180	<del>-4370</del> <del>-4950</del>	300	O-ring	B
X-107B	Power and Control	13500	180	<del>-4850</del> 1425	450	O-ring	B
X-110	<del>FCS Suction</del> Spare	<del>43500</del> 20100	<del>5599</del>	<del>40000</del>	300	<del>O-ring</del> Welded Cap	<del>B</del> CA
X-111	Spare	<del>43500</del> <del>45000</del> 20100	<del>280</del> 260.5	<del>43500</del>	300	O-ring	B
X-112	Spare	<del>43500</del> <del>40000</del> 20100	<del>480</del> <del>342</del> 79.5	<del>-52500</del>	300	O-ring	B
<del>X-113</del>	<del>Spare</del>	<del>43500</del> <del>40000</del>	<del>180</del> <del>264</del>	<del>4350</del>	<del>300</del>	<del>O-ring</del>	<del>B</del>
X-130A	I & C	13500	45	0	300	<del>Valve</del> <del>O-ring</del>	<del>BA</del>
X-130B	I & C	13500	212	0	300	<del>Valve</del> <del>O-ring</del>	<del>BA</del>
X-130C	I & C	13500	124	0	300	<del>Valve</del> <del>O-ring</del>	<del>BA</del>
X-130D	I & C	13500	295	0	300	<del>Valve</del> <del>O-ring</del>	<del>BA</del>
X-140A	I & C	<del>12935</del> 43500	45	<del>-2500</del> <del>-27000</del>	<del>250</del> 300	<del>Valve</del> <del>O-ring</del>	<del>BA</del>
X-140B	I & C	13500	300	0	300	<del>Valve</del> <del>O-ring</del>	<del>BA</del>
X-141A	I & C	13500	63.5	0	300	<del>Valve</del> <del>O-ring</del>	<del>BA</del>

Table 6.2-8 Primary Containment Penetration List\* (Continued)

Penetration Number	Name	Elevation (mm)	Azimuth (deg)	Offset (mm)	Diameter (mm)	Barrier Type	Testing††
X-141B	I & C	<del>43500</del> 13500	<del>275</del> 275	<del>-0</del> 0	<del>300</del> 300	O-ring	BA
X-141B	I & C					Valve	
X-142A	I & C	20100	38	0	90	Valve O-ring	BA
X-142B	I & C	20100	244	0	90	Valve O-ring	BA
X-142C	I & C	20100	116	0	90	Valve O-ring	BA
X-142D	I & C	20100	<u>296.5</u>	2000	90	Valve O-ring	BA
X-143A	I & C	14700	<u>45</u>	0	90	Valve O-ring	BA
X-143B	I & C	14700	<u>212</u>	0	90	Valve O-ring	BA
X-143C	I & C	14700	<u>124</u>	0	90	Valve O-ring	BA
X-143D	I & C	14700	<u>300</u>	0	90	Valve O-ring	BA
X-144A	I & C	<del>12700</del> <del>42650</del>	<u>45</u>	0	90	Valve O-ring	BA
X-144B	I & C	<del>12700</del> <del>42650</del>	<u>212</u>	0	90	Valve O-ring	BA
X-144C	I & C	<del>12700</del> <del>42650</del>	<u>124</u>	0	90	Valve O-ring	BA
X-144D	I & C	<del>12700</del> <del>42650</del>	<u>300</u>	0	90	Valve O-ring	BA
X-146A	I & C	19000	<u>38</u>	0	300	Valve O-ring	BA
X-146B	I & C	19000	<u>248</u>	0	300	Valve O-ring	BA
X-146C	I & C	19000	<u>112</u>	0	300	Valve O-ring	BA
X-146D	I & C	19000	<u>296.5</u>	0	300	Valve O-ring	BA
X-147	I & C	20100	<u>248</u>	0	<del>90</del> 400	Valve O-ring	BA
X-160	LDS Monitor	20100	<u>4642</u>	0	250	Valve O-ring	BA
X-161A	CAMS I & C	<del>44700</del> 20100	<del>45</del> <u>42.75</u>	<del>-4000</del> <sup>0</sup>	250	O-ring- Welded Cap	B C A
X-161B	CAMS I & C	<del>14700</del> 20100	<del>290</del> <u>292.5</u>	0	250	O-ring- Welded Cap	B C A

Table 6.2-8 Primary Containment Penetration List\* (Continued)

Penetration Number	Name	Elevation (mm)	Azimuth (deg)	Offset (mm)	Diameter (mm)	Barrier Type	Testing††
X-162A	CAMS I & C Sample/Return Drywell Gas	19000	116	0	250	O-ring-Valve	BA
X-162B	CAMS I & C Sample/Return Drywell Gas	19000	244	0	250	O-ring-Valve	BA
X-170	I & C	13400	<u>310</u>	<u>0</u>	<u>200</u>	Valve O-ring	BA
<del>X-174</del> X-171	<del>I &amp; C</del> I & C	<del>44700</del> <b>16400</b>	<del>55</del> <b>45</b>	<del>-1000</del> <b>-2700</b>	<del>300</del> <b>250</b>	O-ring Valve	BA
X-177	I & C	15900	135	-500	250	Valve O-ring	BA
X-200B	Wetwell Spray	8900	258	0	100	Valve	A
X-200C	Wetwell Spray	8900	102	0	100	Valve	A
X-201	RHR Pump Suction (A)	<del>-7200</del> <b>-7085</b>	36	0	450	Valve	A
X-202	RHR Pump Suction (B)	<del>-7200</del> <b>-7085</b>	216	0	450	Valve	A
X-203	RHR Pump Suction (C)	<del>-7200</del> <b>-7085</b>	144	0	450	Valve	A
X-204	RHR Pump Test (A)	<del>4200</del> <b>800</b>	<del>86</del> <b>266</b> <b>85</b>	0	250	Valve	A
X-205	RHR Pump Test (B)	<del>4200</del> <b>800</b>	<del>266</del> <b>265</b>	0	250	Valve	A
X-206	RHR Pump Test (C)	<del>4200</del> <b>800</b>	<del>94</del> <b>95</b>	0	250	Valve	A
X-210	HPCF Pump Suction (B)	<u>-7085</u>	<u>252</u>	0	400	Valve	A
X-211	HPCF Pump Suction (C)	<u>-7085</u>	<u>108</u>	0	400	Valve	A
X-213	RCIC Turbine Exhaust	<del>5800</del> <b>5848</b>	60	0	550	Valve	AC
X-214	RCIC Pump Suction	<u>-7050</u>	<u>72</u>	0	200	Valve	A
<del>X-215</del>	<del>RCIC Vacuum Pump</del>	<del>2000</del>	<del>70</del>	<del>0</del>	<del>250</del>		A
X-216	SPCU Pump Suction	<u>-7450</u>	283	0	200	Valve	A
X-217	SPCU Return	<u>1700</u>	340	0	250	Valve	A
X-220	MSIV Leak-off	9200	45	-2000	250		B
X-240	Wetwell Purge Suction	9200	45	1200	<del>550</del> <b>500</b> <b>550</b>	Valve	AC

Table 6.2-8 Primary Containment Penetration List\* (Continued)

Penetration Number	Name	Elevation (mm)	Azimuth (deg)	Offset (mm)	Diameter (mm)	Barrier Type	Testing††
X-241	Wetwell Purge Exhaust	9200	<del>230</del> <u>221</u>	0	<del>550</del> <del>500</del> <u>550</u>	Valve	<u>AC</u>
X-242	FCS Return Spare	1500	225	-1000	150	Welded Cap	<del>AC</del>
X-250	Spare Breathing Air	<del>8500</del> <del>20400</del> <u>19000</u>	<del>45</del> <del>60</del> <u>296.5</u>	<del>0</del> <u>3000</u>	<del>400</del> <del>40</del> <u>200</u>	Valve	<u>AC</u>
X-251	Spare	-9000	213	-0	400		A
X-252	FCS Return Spare	1500	50	0	300	Welded Cap	<del>B</del> <u>CA</u>
X-253	Spare	2650	135	1000	300		B
X-254	Spare	2650	225	-1000	300	Welded Cap	<del>BA</del>
X-255	Spare	1200	282	-0	300		B
X-300A	I & C	-7300	134	-0	300	O-ring	B
X-300B	I & C	-7300	211	-0	300	O-ring	B
X-320 <u>X-320</u>	<del>I &amp; C</del> <u>I &amp; C</u>	<del>-8000</del> <u>8900</u>	<del>74</del> <u>74</u>	<del>-0</del>	<del>90</del> <u>90</u>	<del>O-ring</del> <u>Valve</u>	<del>BA</del>
X-321A	I & C	<del>-2050</del>	<del>97</del> <u>5112</u>	0	300	<del>O-ring</del> <u>Valve</u>	<del>B</del> A
X-321B	I & C	<del>6000</del> <u>2200</u>	<del>262</del> <u>5248</u>	0	300	<del>O-ring</del> <u>Valve</u>	<del>B</del> A
X-322A	I & C	400	78	0	90	<del>O-ring</del> <u>Valve</u>	<del>B</del> A
X-322B	I & C	400	258	0	90	<del>O-ring</del> <u>Valve</u>	<del>B</del> A
X-322C	I & C	400	102	0	90	<del>O-ring</del> <u>Valve</u>	<del>B</del> A
X-322D	I & C	400	282	0	90	<del>O-ring</del> <u>Valve</u>	<del>B</del> A
X-322E	I & C	<del>2000</del> See Note 1	<del>94</del> <u>106</u>	0	90	<del>O-ring</del> <u>Valve</u>	<del>B</del> A
X-322F	I & C	<del>2000</del> See Note 1	<del>266</del> <u>282</u>	0	90	<del>O-ring</del> <u>Valve</u>	<del>B</del> A
X-323A	I & C	-5200	30	0	90	Valve <del>O-ring</del>	<del>BA</del>
<u>X-323B</u>	<u>I &amp; C</u>	<u>-5200</u>	<u>210</u>	<u>0</u>	<u>90</u>	Valve <del>O-ring</del>	<del>BA</del>
<u>X-323C</u>	<u>I &amp; C</u>	<u>-5200</u> <u>-5500</u>	<u>456</u> <u>138</u>	<u>0</u>	<u>90</u>	Valve <del>O-ring</del>	<del>BA</del>



Table 6.2-8 Primary Containment Penetration List\* (Continued)

Penetration Number	Name	Elevation (mm)	Azimuth (deg)	Offset (mm)	Diameter (mm)	Barrier Type	Testing†‡
X-323D	I & C	-5200	304	0	90	<del>Valve</del> <del>O-ring</del>	<del>BA</del>
X-323E	I & C	-7500	100	0	90	<del>Valve</del> <del>O-ring</del>	<del>BA</del>
X-323F	I & C	-7500	230	0	90	<del>Valve</del> <del>O-ring</del>	<del>BA</del>
X-331A	CAMS Gamma Det.	<del>7300</del> <u>9700</u>	<del>307</del> <u>6.5</u>	0	250	<del>O-ring</del> Welded Cap	<del>B CA</del>
X-331B	CAMS Gamma Det.	<del>7300</del> <u>9700</u>	<del>207</del> <u>231</u>	0	250	<del>O-ring</del> Welded Cap	<del>B CA</del>
X-332A	CAMS Sampling Ret.	<del>8000</del> <u>9700</u>	<del>94</del> <u>97</u>	0	300	<del>O-ring</del> Valve	<del>B A</del>
X-332B	CAMS Sampling Ret.	<del>8000</del> <u>9700</u>	<del>266</del> <u>261</u>	0	300	<del>O-ring</del> Valve	<del>B A</del>
<u>X-342</u>	<u>I &amp; C</u>	<u>9500</u>	<u>266</u>	<u>0</u>	<u>90</u>	<del>Valve</del> <del>O-ring</del>	<del>BA</del>
X-600A	TIP Drive	<del>4580</del> <u>1693</u>	0	<del>450</del> <u>700</u>	<u>50 40</u>	Valve	A
X-600B	TIP Drive	<del>4580</del> <u>1693</u>	0	<u>0</u>	<u>50 40</u>	Valve	A
X-600C	TIP Drive	<del>4580</del> <u>1693</u>	0	<del>450</del> <u>700</u>	<u>50 40</u>	Valve	A
<del>X-600D</del> <u>X-600D</u>	<del>TIP Drive Purge</del> <u>TIP Drive Purge</u>	<del>4580</del> <u>1693</u>	<u>0</u>	<del>730</del> <u>420</u>	<u>50 40</u>	Valve	<del>AA</del>
X-700A	RIP Purge Water Supply	<del>500</del> <u>265</u>	180	<del>4780</del> <del>-1750</del>	<u>35 25 15</u>	Valve	A
X-700B	RIP Purge Water Supply	<del>500</del> <u>265</u>	180	<del>4640</del> <del>-1610</del>	<u>35 25 15</u>	Valve	A
X-700C	RIP Purge Water Supply	<del>500</del> <u>515</u>	180	<del>4500</del> <del>-1750</del>	<u>35 25 15</u>	Valve	A
X-700D	RIP Purge Water Supply	<del>760</del> <u>515</u>	180	<del>4780</del> <del>-1610</del>	<u>35 25 15</u>	Valve	A
X-700E	RIP Purge Water Supply	<del>760</del> <u>765</u>	180	<del>4640</del> <del>-1610</del>	<u>35 25 15</u>	Valve	A
X-700F	RIP Purge Water Supply	<del>760</del> <u>265</u>	180	<del>4500</del> <del>-1470</del>	<u>35 25 15</u>	Valve	A
X-700G	RIP Purge Water Supply	<del>930</del> <u>15</u>	180	<del>4780</del> <del>-1330</del>	<u>35 25 15</u>	Valve	A
X-700H	RIP Purge Water Supply	<del>930</del> <u>15</u>	180	<del>4640</del> <del>-1470</del>	<u>35 25 15</u>	Valve	A
X-700J	RIP Purge Water Supply	<del>4400</del> <u>15</u>	180	<del>4780</del> <del>-1610</del>	<u>35 25 15</u>	Valve	A

Table 6.2-8 Primary Containment Penetration List\* (Continued)

Penetration Number	Name	Elevation (mm)	Azimuth (deg)	Offset (mm)	Diameter (mm)	Barrier Type	Testing†‡
X-700K	RIP Purge Water Supply	<del>4100</del> 15	180	<del>4640</del> <del>1750</del>	<del>35 25</del> 15	Valve	A
X-710	CRD Insertion (Total <del>403</del> 102)	<del>4240</del> 1285	180	<del>4780</del> <del>1680</del>	<del>6032</del>	Valve	A
X-740	Spare	<del>250</del> 85	180	<del>4840</del> <del>1750</del>	100	Welded Cap	A <del>GA</del>
X-750A	I&C (Core Diff Press.)	<del>250</del> <del>900</del> 1135	180	<del>4780</del> <del>910</del>	<del>4020</del>	<del>O-ring</del> Valve	<del>BA</del>
X-750B	I&C (Core Diff Press.)	<del>250</del> 985	180	<del>4640</del> <del>1330</del>	<del>4020</del>	<del>O-ring</del> Valve	<del>BA</del>
X-750C	I&C (Core Diff Press.)	<del>250</del> 1285	180	<del>4640</del> <del>910</del>	<del>4020</del>	<del>O-ring</del> Valve	<del>BA</del>
X-750D	I&C (Core Diff Press.)	<del>250</del> 985	180	<del>4780</del> <del>1470</del>	<del>4020</del>	<del>O-ring</del> Valve	<del>BA</del>
X-751A	I&C (RIP Diff Press.)	<del>420</del> 985	180	<del>4780</del> <del>1470</del>	<del>4020</del>	<del>O-ring</del> Valve	<del>BA</del>
X-751B	I&C (RIP Diff Press.)	<del>420</del> 1285	180	<del>4640</del> <del>910</del>	<del>4020</del>	<del>O-ring</del> Valve	<del>BA</del>
X-751C	I&C (RIP Diff Press.)	<del>420</del> 985	180	<del>4640</del> <del>1330</del>	<del>4020</del>	<del>O-ring</del> Valve	<del>BA</del>
X-751D	I&C (RIP Diff Press.)	<del>420</del> 1135	180	<del>4780</del> <del>910</del>	<del>4020</del>	<del>O-ring</del> Valve	<del>BA</del>
X-780A	Spare	<del>250</del> 235	180	<del>4500</del> <del>1190</del>	<del>4020</del>	Welded Cap	B <del>GA</del>
X-780B	Spare	<del>500</del> 235	180	<del>4640</del> <del>1190</del>	<del>4020</del>	Welded Cap	B <del>GA</del>
X-610	CRD Insertion (Total <del>402</del> 103)	<del>4240</del> 1285	0	<del>4780</del> <del>1680</del>	<del>6032</del>	Valve	A
X-620	Low Conductivity Drain	<del>590</del> <del>650</del> 700	0	<del>4020</del> <del>1750</del>	<del>75 65</del> 65		A
X-621	High Conductivity Drain	<del>590</del> <del>650</del> 450	0	<del>4020</del> <del>1750</del>	<del>450 65</del> 150		A
X-650A	I&C (Core Diff Press.)	<del>250</del> 985	0	<del>4640</del> <del>1330</del>	<del>4020</del>	<del>O-ring</del> Valve	<del>BA</del>
X-650B	I&C (Core Diff Press.)	<del>250</del> 1285	0	<del>4740</del> <del>910</del>	<del>4020</del>	<del>O-ring</del> Valve	<del>BA</del>
X-650C	I&C (Core Diff Press.)	<del>250</del> 985	0	<del>4780</del> <del>1470</del>	<del>4020</del>	<del>O-ring</del> Valve	<del>BA</del>
X-650D	I&C (Core Diff Press.)	<del>250</del> 1135	0	<del>4570</del> <del>910</del>	<del>4020</del>	<del>O-ring</del> Valve	<del>BA</del>
X-651A	I&C (RIP Diff Press.)	<del>420</del> 1285	0	<del>4640</del> <del>910</del>	<del>4020</del>	<del>O-ring</del> Valve	<del>BA</del>

Table 6.2-8 Primary Containment Penetration List\* (Continued)

Penetration Number	Name	Elevation (mm)	Azimuth (deg)	Offset (mm)	Diameter (mm)	Barrier Type	Testing†‡
X-651B	I&C (RIP Diff Press.)	<del>-420985</del>	0	<del>-1710</del> <del>-1330</del>	<u>4020</u>	<del>O-ring</del> <u>Valve</u>	<del>BA</del>
X-651C	I&C (RIP Diff Press.)	<del>-4201135</del>	0	<del>1780</del> <u>910</u>	<u>4020</u>	<del>O-ring</del> <u>Valve</u>	<del>BA</del>
X-651D	I&C (RIP Diff Press.)	<del>-420985</del>	0	<del>1670</del> <del>-1470</del>	<u>4020</u>	<del>O-ring</del> <u>Valve</u>	<del>BA</del>
X-680A	Spare	<del>-25085</del>	<u>0</u>	<del>1600</del> <del>-1750</del>	<u>4020</u>	<u>Welded</u> <u>Cap</u>	<del>BA</del>
X-680B	Spare	-250 <del>-50085</del>	0	<del>1430</del> <u>1750</u>	<u>4020</u>		B

Note 1: Penetration will be located such that bottom of penetration sleeve is above revised pool swell impact zone (7700 mm).

Table 6.2-9 Secondary Containment Penetration List\* (Continued)

Penetration Number	Name	Elevation (mm)	Diameter (mm)
50	HNCW	12300	<del>200</del> <u>250</u>
51	HNCW	12300	<del>200</del> <u>250</u>
60	BAS	-1700	80
61	BAS	-1700	80

Table 6.2-10 Potential Bypass Leakage Paths

Penetration Number	Name	Diameter (mm)	Termination Region	Leakage Barriers	Potential Bypass Path
X-5	L/D Personnel Hatch	<del>2400</del> <b>5000</b> <b>4300</b>	S	C/M-J	No
X-6	L/D Equipment Hatch	<del>2400</del> <b>5000</b> <b>4300</b>	S	C/M-J	No
X-32BA	LPFL (B) RHR (B)	650	S	E/C/L	No
X-32CB	LPFL (C) RHR (C)	650	S	E/C/L	No
X-69	SA	90	E	<b>E/D/H</b>	No
<del>X-80</del>	<del>Drywell Purge Suction</del>	<del>550</del> <b>500</b>	<del>E</del>	<del>E/C/J</del>	<del>Yes</del>
<del>X-81</del>	<del>Drywell Purge Exhaust</del>	<del>550</del> <b>500</b>	<del>E</del>	<del>E/C/J</del>	<del>Yes</del>
<b>X-82</b>	<b>FCS Suction Spare</b>	<b>150</b>	<b>S</b>	<b>E/C/J</b>	<b>No</b>
X-91	Spare	<del>400</del> <b>300</b>	P	B/A	No
X-92	Spare	<del>400</del> <b>300</b>	P	B/A	No
X-94	Spare	400	S	B/A	No
X-95	Spare	400	S	B/A	No
X-100C	IP Power	<del>450</del> <b>300</b>	S	C/J	No
X-100F	RIP Power	450	S	C/J	No
X-101A	LP Power	<del>300</del> <b>450</b>	S	C/J	No
X-101B	LP Power	<del>300</del> <b>450</b>	S	C/J	No
X-101J	LP Power	300	S	C/J	No
X-101K	LP Power	300	S	C/J	No
X-102B	I & C	<del>300</del> <b>450</b>	S	C/J	No
X-102H	I & C	300	S	C/J	No
X-102J	I & C	300	S	C/J	No
X-103A	I & C	<del>300</del> <b>150</b>	S	C/J	No
X-103B	I & C	<del>300</del> <b>150</b>	S	C/J	No
X-103C	I & C	<del>300</del> <b>150</b>	S	C/J	No
<b>X-103D</b>	<b>I &amp; C</b>	<b>150</b>	<b>S</b>	<b>C/J</b>	<b>No</b>
X-103E	I & C	300	S	C/J	No
X-104C	FMCRD Pos. Indicator	<del>300</del> <b>450</b>	S	C/J	No
X-104D	FMCRD Pos. Indicator	<del>300</del> <b>450</b>	S	C/J	No
X-104F	FMCRD Pos. Indicator	<del>300</del> <b>450</b>	S	C/J	No
X-104H	FMCRD Pos. Indicator	<del>300</del> <b>450</b>	S	C/J	No
X-105A	Neutron Detection	<del>300</del> <b>450</b>	S	C/J	No
X-105B	Neutron Detection	<del>300</del> <b>450</b>	S	C/J	No
X-105C	Neutron Indicator	<del>300</del> <b>450</b>	S	C/J	No
X-105D	Neutron Indicator	<del>300</del> <b>450</b>	S	C/J	No

Table 6.2-10 Potential Bypass Leakage Paths

Penetration Number	Name	Diameter (mm)	Termination Region	Leakage Barriers	Potential Bypass Path
<del>X-105E</del>	<del>Neutron Indicator</del>	<del>450</del>	<del>S</del>	<del>G/J</del>	<del>Ne</del>
<del>X-105F</del>	<del>Neutron Indicator</del>	<del>450</del>	<del>S</del>	<del>G/J</del>	<del>Ne</del>
<del>X-105G</del>	<del>Neutron Indicator</del>	<del>450</del>	<del>S</del>	<del>G/J</del>	<del>Ne</del>
<del>X-105H</del>	<del>Neutron Indicator</del>	<del>450</del>	<del>S</del>	<del>G/J</del>	<del>Ne</del>
X-106A	Div I Instrumentation	300	S	C/J	No
X-106B	Div II Instrumentation	300	S	C/J	No
X-106C	Div III Instrumentation	300	S	C/J	No
X-106D	Div IV Instrumentation	300	S	C/J	No
X-106F	Div IV Instrumentation	300	S	C/J	No
X-106G	Div IV Instrumentation	300	S	C/J	No
X-106H	Div IV Instrumentation	300	S	C/J	No
X-106J	Div IV Instrumentation	300	S	C/J	No
X-107A	Group B Instr	300	S	C/J	No
X-107B	Power and Control	300	S	C/J	No
<b>X-110</b>	<b>FCS Suction Spare</b>	<b>450300</b>	<b>S</b>	<b>E/C/J</b>	<b>No</b>
<del>X-113</del>	<del>Spare</del>	<del>300</del>	<del>P</del>	<del>B/A</del>	<del>Ne</del>
X-140A	I & C	<del>300</del> 250	S	C/J	No
X-162A	<del>CAMS I&amp;C Sample/Return</del> Drywell Gas	250	S	C/J	No
	<del>CAMS I&amp;C Sample/Return</del> Drywell Gas	250	S	C/J	No
<del>X-141BX-141B</del>	<del>I&amp;C I &amp; C</del>	<del>300</del> 300	<del>SS</del>	<del>G/JC/J</del>	<del>NeNo</del>
<del>X-172177</del>	<del>I &amp; C</del>	250	S	C/J	No
<del>X-171X-171</del>	<del>I&amp;C I &amp; C</del>	<del>300</del> 250	<del>SS</del>	<del>G/JC/J</del>	<del>NeNo</del>
X-200AB	Wetwell Spray	100	S	C/H	No
X-200BC	Wetwell Spray	100	S	C/H	No
X-220	MSIV Leakage	250	S	G/G	Ne
<del>X-215</del>	<del>RCIC Vacuum Pump Ex.</del>	<del>250</del>	<del>S</del>	<del>G/G</del>	<del>Ne</del>
X-240	Wetwell Purge Suction	<del>550</del> <b>500550</b>	E	E/C/J	Yes
X-241	Wetwell Purge Exhaust	<del>550</del> <b>500550</b>	E	E/C/J	Yes
<b>X-242</b>	<b>FCS Suction Spare</b>	<b>150</b>	<b>S</b>	<b>E/C/J</b>	<b>No</b>
X-250	<del>Spare</del> Breathing Air	200	<del>P</del> E	<del>B/A</del> E/D	No
<del>X-251</del>	<del>Spare</del>		<del>P</del>	<del>B/A</del>	<del>Ne</del>

Table 6.2-10 Potential Bypass Leakage Paths (Continued)

Penetration Number	Name	Diameter (mm)	Termination Region	Leakage Barriers	Potential Bypass Path
<del>X-252</del>	<del>FCS Suction Spare</del>	<del>450300</del>	<del>S</del>	<del>E/C/J</del>	<del>No</del>
<del>X-253</del>	<del>Spare</del>	<del>300</del>	<del>S</del>	<del>B/A</del>	<del>Ne</del>
<del>X-254</del> <del>X-254</del>	<del>SpareSpare</del>	<del>300300</del>	<del>SS</del>	<del>B/A/B/A</del>	<del>NeNo</del>
<del>X-255</del>	<del>Spare</del>	<del>300</del>	<del>S</del>	<del>B/A</del>	<del>Ne</del>
<del>X-300A</del>	<del>I&amp;G</del>	<del>300</del>	<del>S</del>	<del>G/J</del>	<del>Ne</del>
<del>X-300B</del>	<del>I&amp;G</del>	<del>300</del>	<del>S</del>	<del>G/J</del>	<del>Ne</del>
<del>X-320</del> <del>X-320</del>	<del>I&amp;G</del> <del>I&amp;C</del>	<del>90</del> <del>90</del>	<del>SS</del>	<del>G/J</del> <del>C/J</del>	<del>Ne</del> <del>No</del>
<del>X-334</del>	<del>I&amp;G</del>	<del>90</del>	<del>S</del>	<del>G/J</del>	<del>Ne</del>
<del>X-341</del>	<del>I&amp;G</del>	<del>90</del>	<del>S</del>	<del>G/J</del>	<del>Ne</del>
X-610	CRD Insertion (Total <del>402</del> 103)	<del>60</del> 32	S	C/J	No
X-620	LCW Drain	<del>75</del> 65	S	C/J	No
X-621	HCW Drain	<del>450</del> 150	S	C/J	No
X-650A	I&C Core Diff Press.	<del>40</del> 20	S	C/J	No
X-650B	I&C Core Diff Press.	<del>40</del> 20	S	C/J	No
X-650C	I&C Core Diff Press.	<del>40</del> 20	S	C/J	No
X-650D	I&C Core Diff Press.	<del>40</del> 20	S	C/J	No
X-651A	I&C RIP Diff Press.	<del>40</del> 20	S	C/J	No
X-651B	I&C RIP Diff Press.	<del>40</del> 20	S	C/J	No
X-651C	I&C RIP Diff Press.	<del>40</del> 20	S	C/J	No
X-651D	I&C RIP Diff Press.	<del>40</del> 20	S	C/J	No
X- <del>660A</del> 600A	TIP Drive	<del>50</del> 40	S	C/J	No
X- <del>660B</del> 600B	TIP Drive	<del>50</del> 40	S	C/J	No
X- <del>660C</del> 600C	TIP Drive	<del>50</del> 40	S	C/J	No
X- <del>660D</del> 600D	TIP Drive Purge	<del>50</del> 40	S	C/J	No
<del>X-660D</del>	<del>TIP Drive Purge</del>	<del>50</del>	<del>S</del>	<del>G/K</del>	<del>Ne</del>
X-680A	Spare	<del>40</del> 20	S	C/K	No
X-680B	Spare	<del>40</del> 20	S	C/K	No
X-700A	RIP Purge Water Supply	<del>35</del> <del>25</del> 15	S	C/H	No
X-700B	RIP Purge Water Supply	<del>35</del> <del>25</del> 15	S	C/H	No
X-700C	RIP Purge Water Supply	<del>35</del> <del>25</del> 15	S	C/H	No

Table 6.2-10 Potential Bypass Leakage Paths (Continued)

Penetration Number	Name	Diameter (mm)	Termination Region	Leakage Barriers	Potential Bypass Path
X-700D	RIP Purge Water Supply	<del>35</del> <b>2515</b>	S	C/H	No
X-700E	RIP Purge Water Supply	<del>35</del> <b>2515</b>	S	C/H	No
X-700F	RIP Purge Water Supply	<del>35</del> <b>2515</b>	S	C/H	No
X-700G	RIP Purge Water Supply	<del>35</del> <b>2515</b>	S	C/H	No
X-700H	RIP Purge Water Supply	<del>35</del> <b>2515</b>	S	C/H	No
X-700J	RIP Purge Water Supply	<del>35</del> <b>2515</b>	S	C/H	No
X-700K	RIP Purge Water Supply	<del>35</del> <b>2515</b>	S	C/H	No
X-710	CRD Insertion (Total 102)	32	S	C/L	No
X-740	Spare	100	S	B/A	No
X-750A	I&C (Core Diff Press.)	<del>48020</del>	S	C/J	No
X-750B	I&C (Core Diff Press.)	<del>48020</del>	S	C/J	No
X-750C	I&C (Core Diff Press.)	<del>48020</del>	S	C/J	No
X-750D	I&C (Core Diff Press.)	<del>48020</del>	S	C/J	No
X-751A	I&C (RIP Diff Press.)	<del>48020</del>	S	C/J	No
X-751B	I&C (RIP Diff Press.)	<del>48020</del>	S	C/J	No
X-751C	I&C (RIP Diff Press.)	<del>48020</del>	S	C/J	No
X-751D	I&C (RIP Diff Press.)	<del>48020</del>	S	C/J	No
X-780A	Spare	<del>48020</del>	S	B/A	No
X-780B	Spare	<del>48020</del>	S	B/A	No



**Figure 6.2-2 ~~Feedwater Line Break — RPV Side Break Area~~ Not Used**

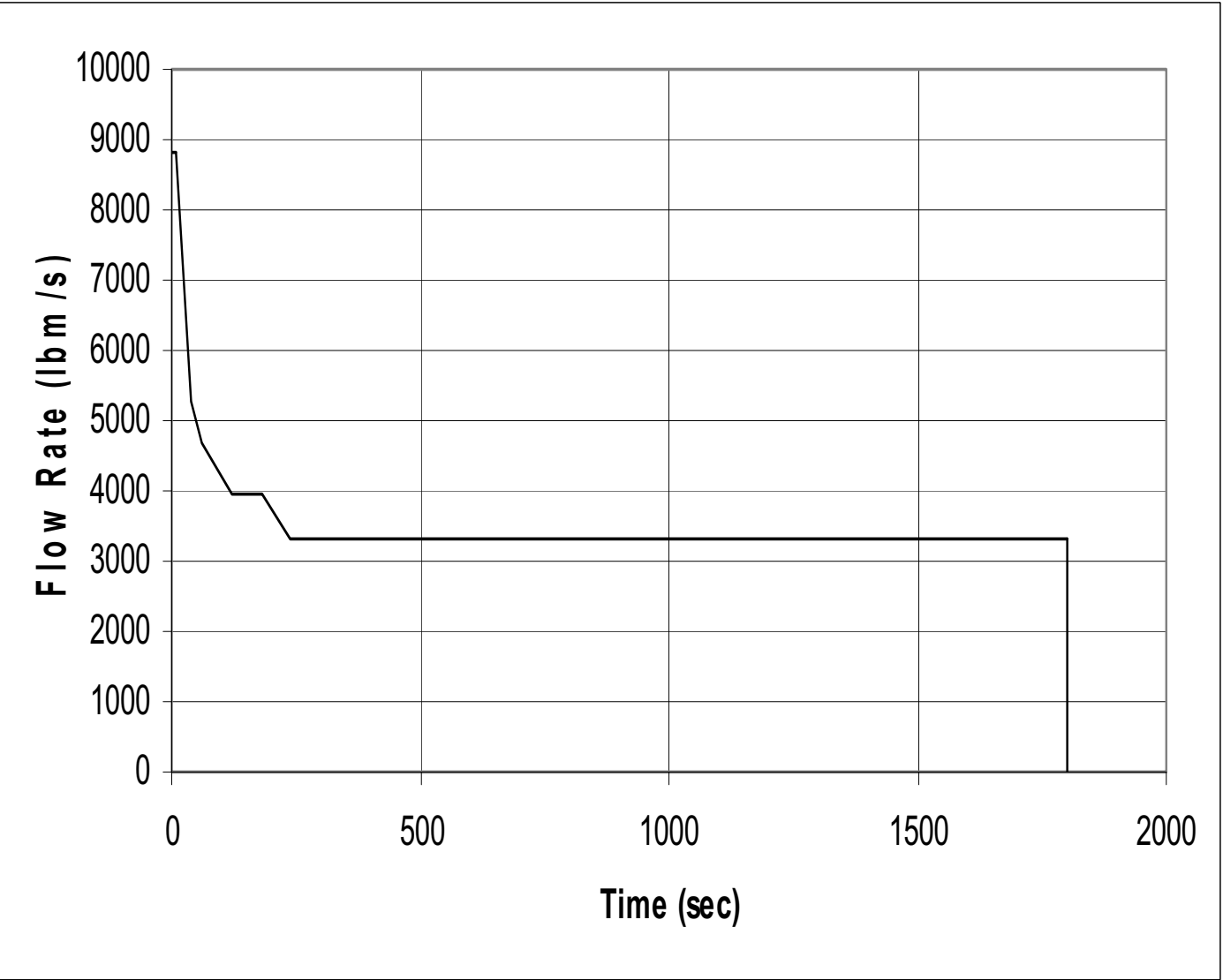

Figure 6.2-3 Feedwater Line Break Flow—Feedwater System Side of Break

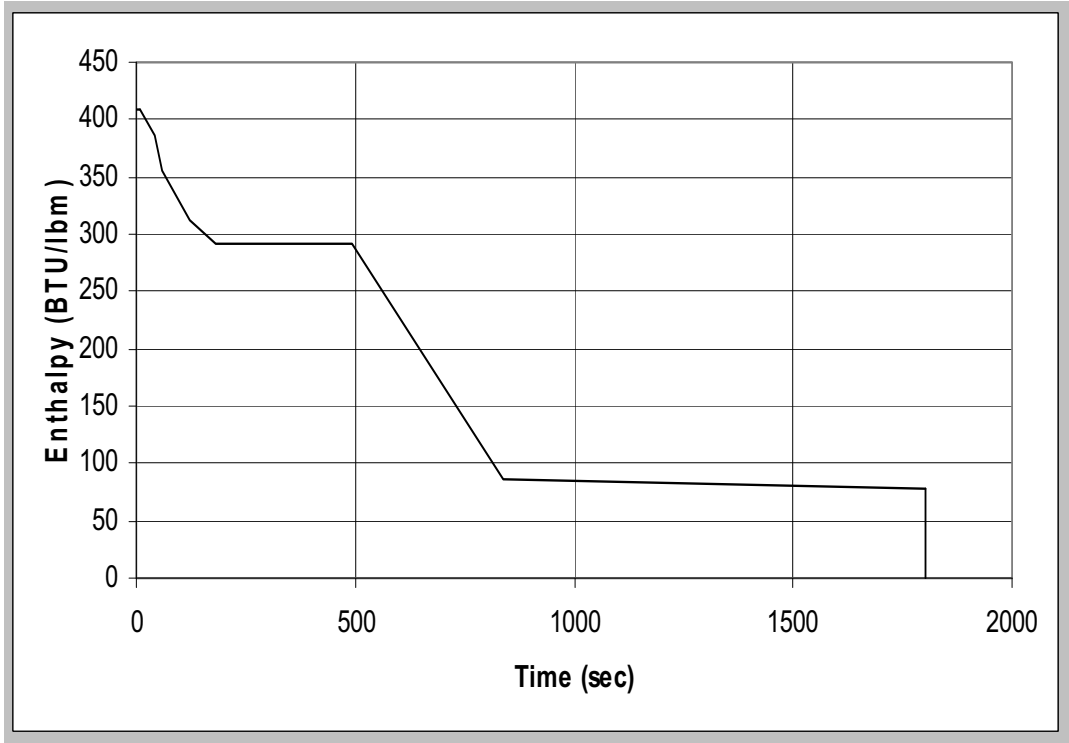

Figure 6.2-4 Feedwater Line Break Flow Enthalpy—Feedwater System Side of Break

**Figure 6.2-5 ~~Lower Drywell Air Transfer Percentage for Model Assumption Versus Actual Case~~Not Used**

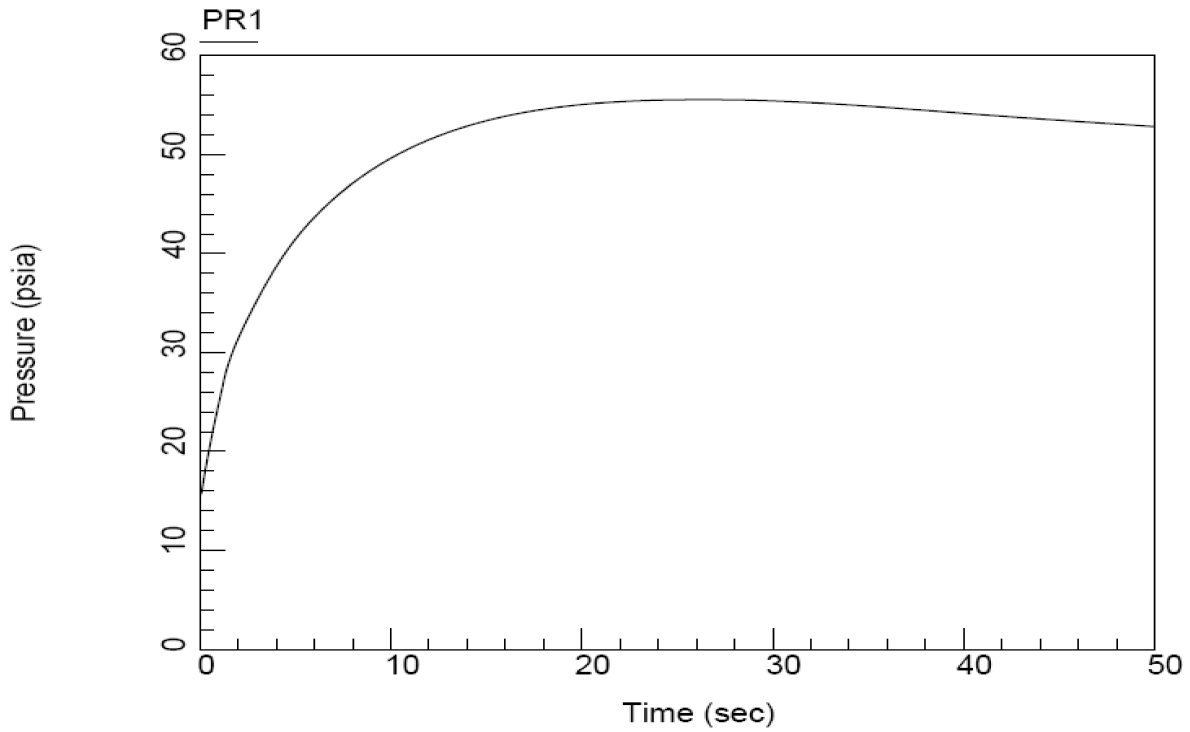

Figure 6.2-6a Drywell Pressure Response for Feedwater Line Break

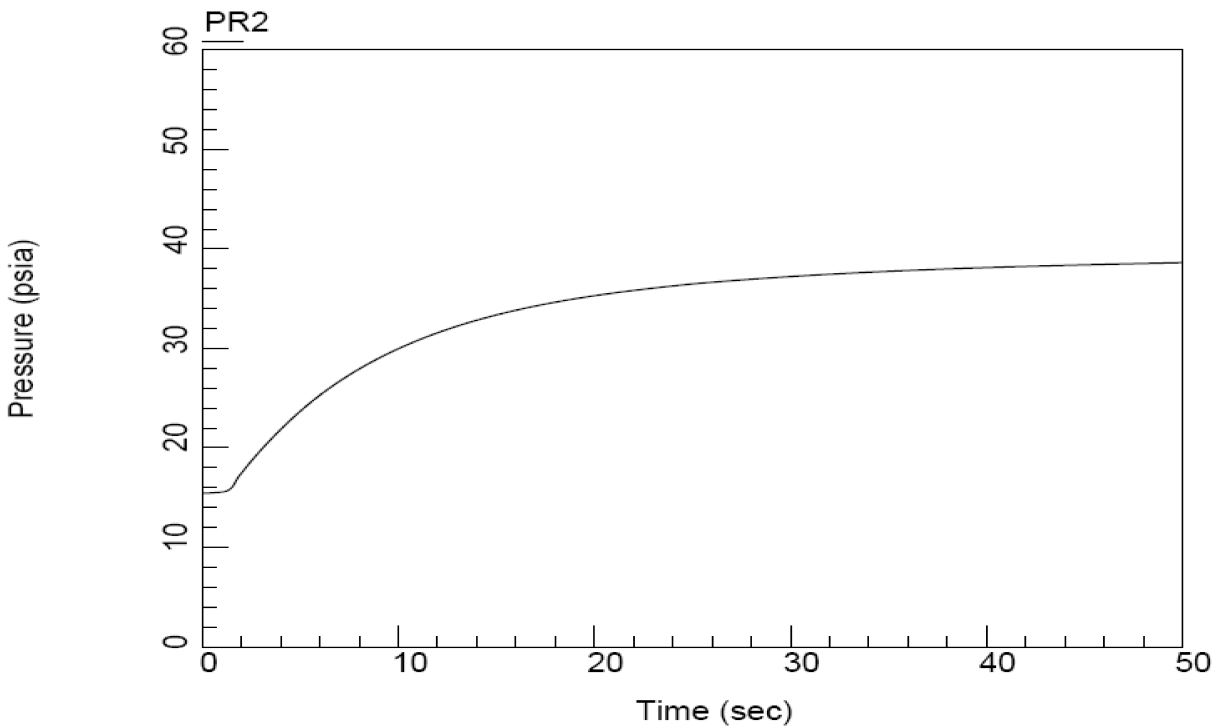

Figure 6.2-6b Wetwell Pressure Response for Feedwater Line Break

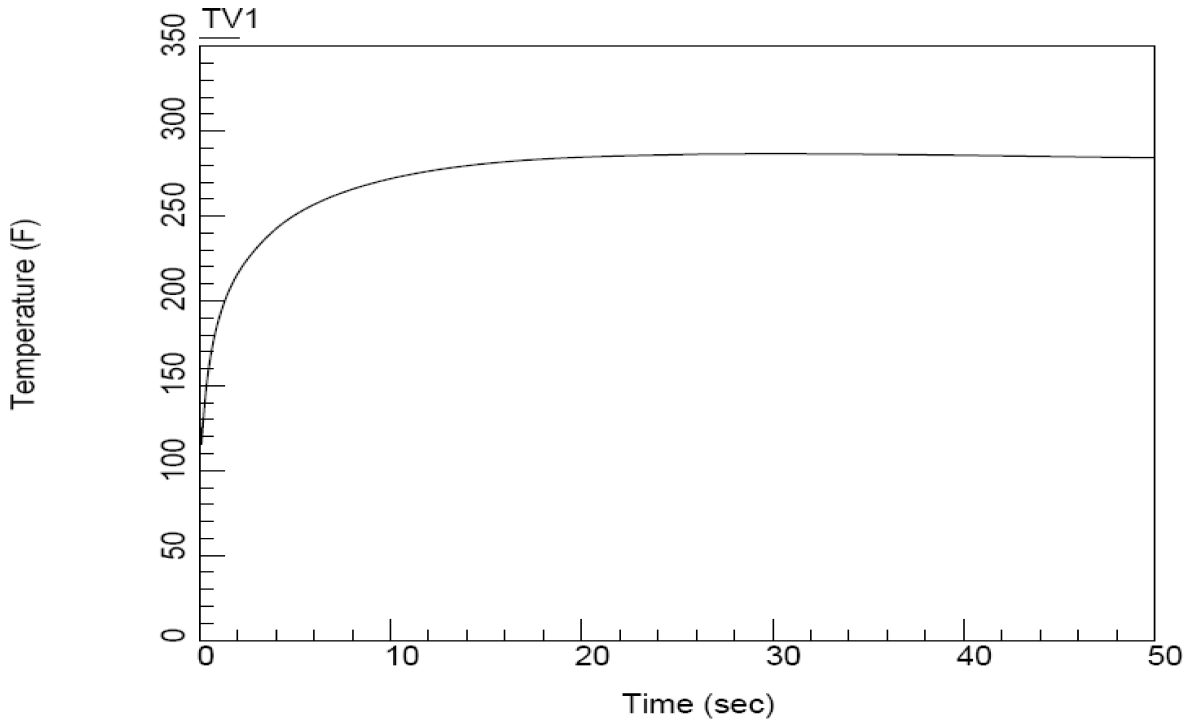

Figure 6.2-7a Temperature Response of Drywell for Feedwater Line Break

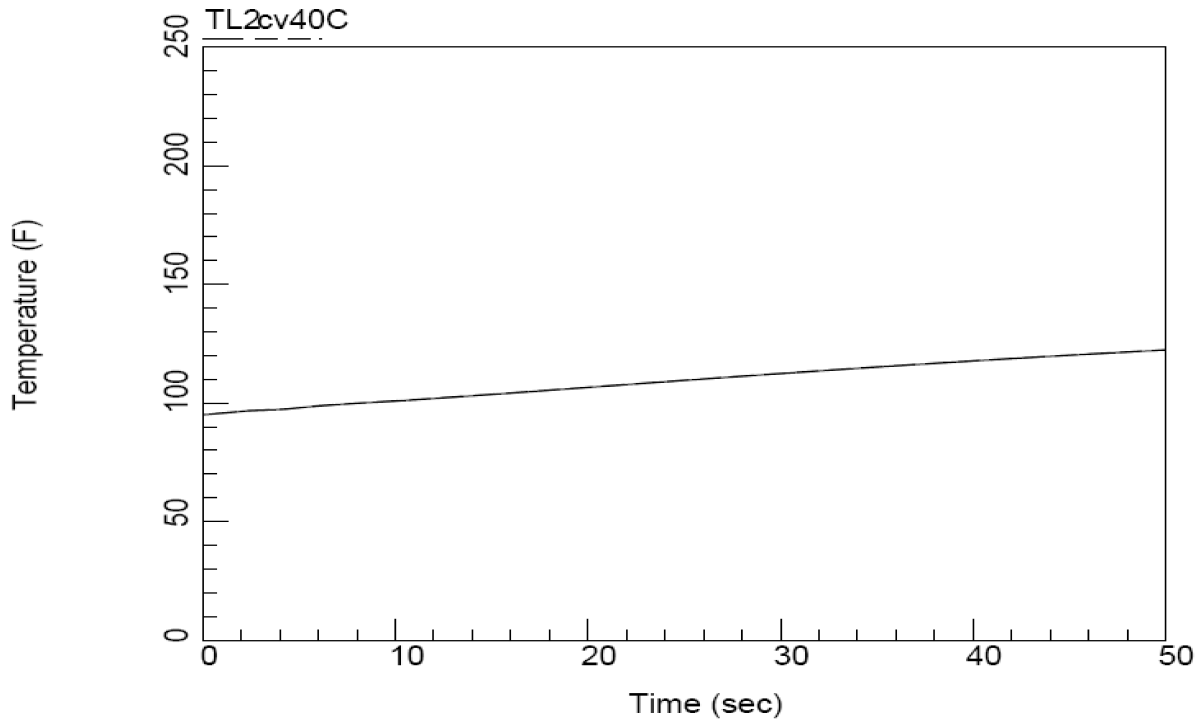

Figure 6.2-7b Temperature Response of Wetwell for Feedwater Line Break

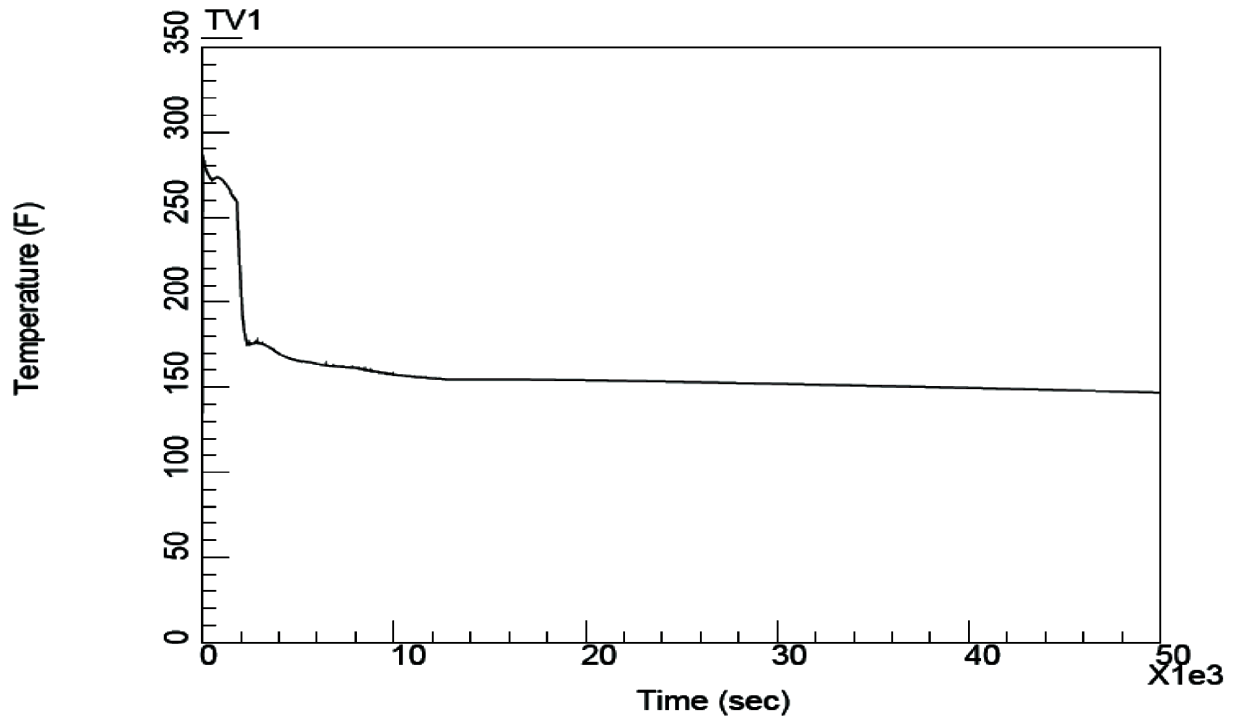

Figure 6.2-8a Drywell Temperature Time History After a Feedwater Line Break

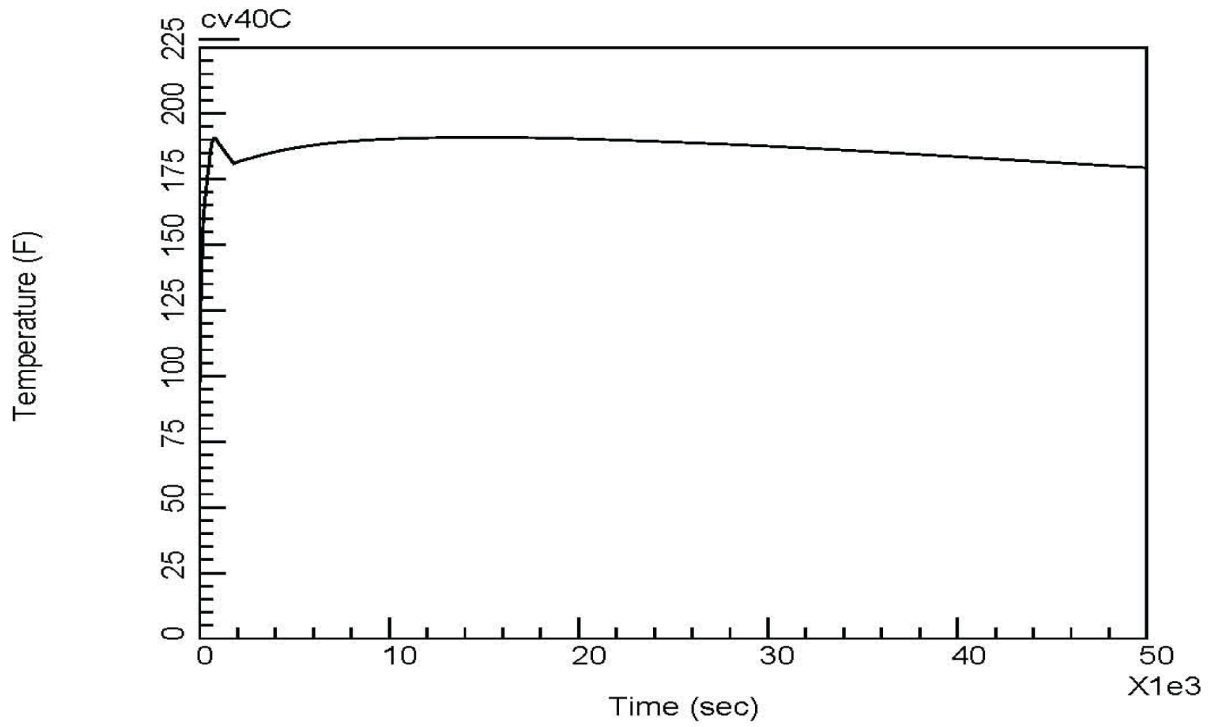

Figure 6.2-8b Suppression Pool Temperature Time History After a Feedwater Line Break



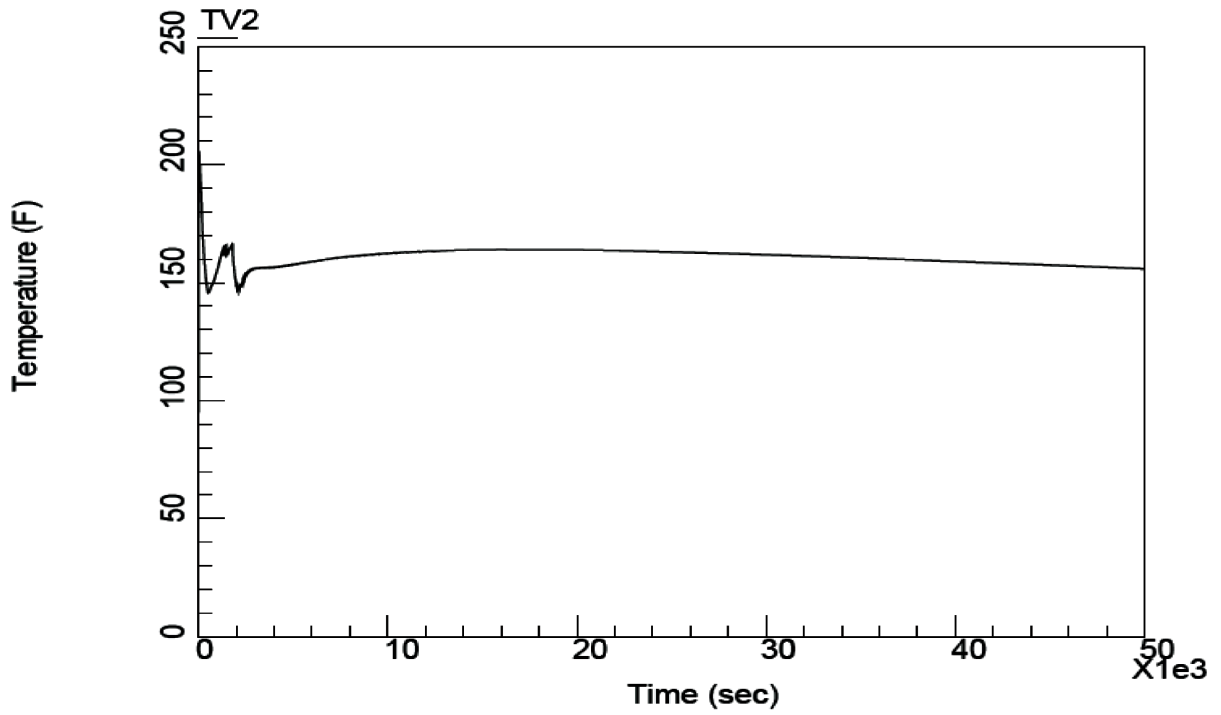

Figure 6.2-8c Wetwell Temperature Time History After a Feedwater Line Break

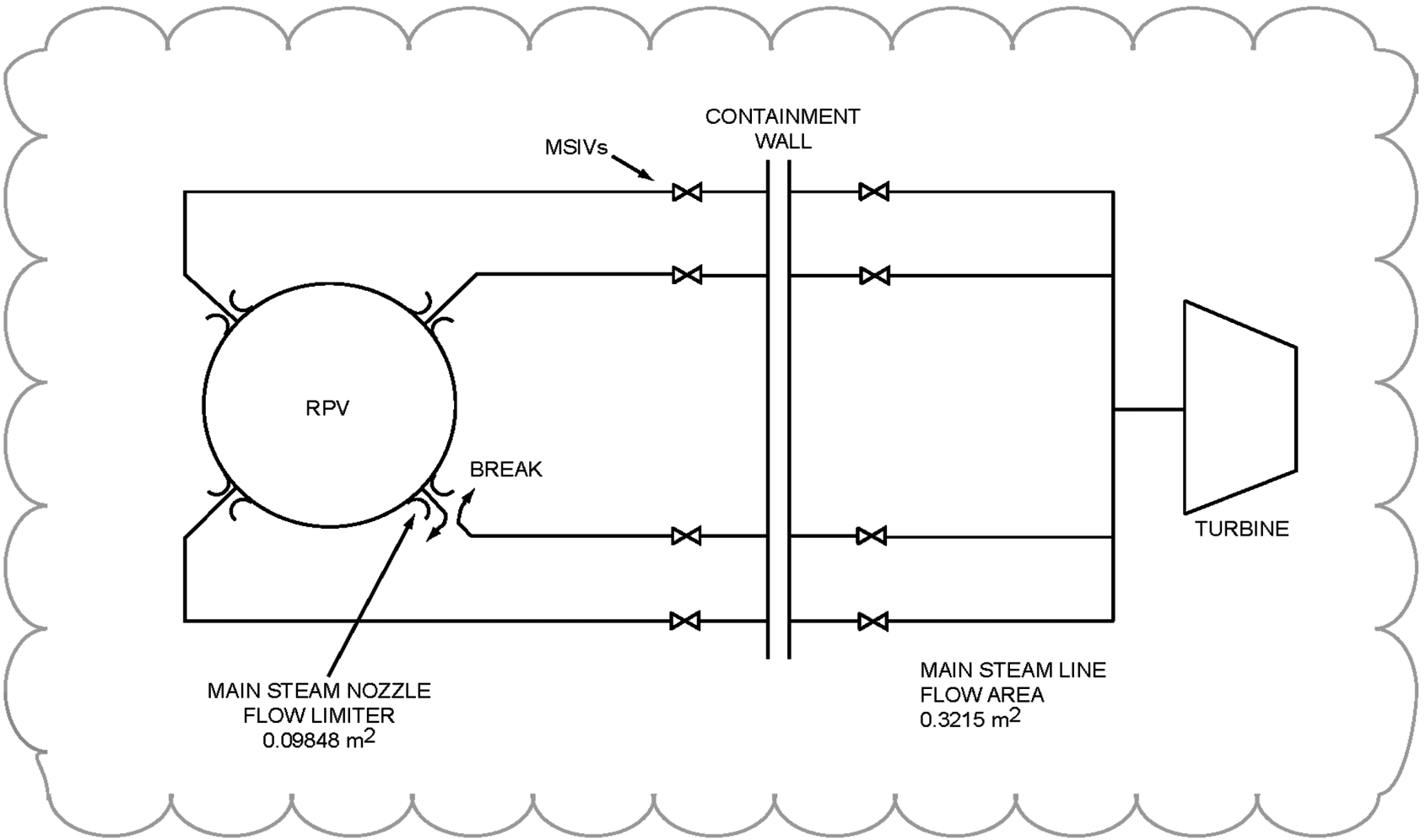

Figure 6.2-9 ABWR Main Steamlines with a Break

Figure 6.2-10 ~~MSLB Area as a Function of Time~~ Not Used

Figure 6.2-11 ~~Feedwater Specific Enthalpy as a Function of Integrated Feedwater Flow Mass~~Not Used

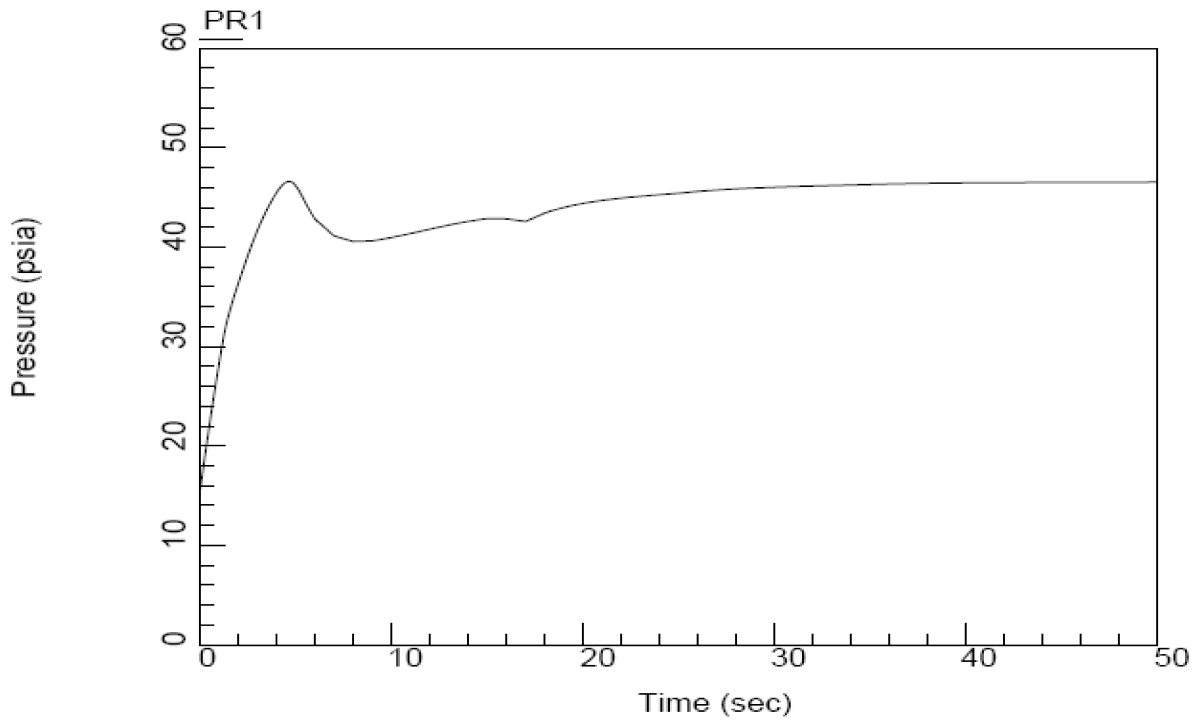

Figure 6.2-12a Drywell Pressure Time History for MSLB

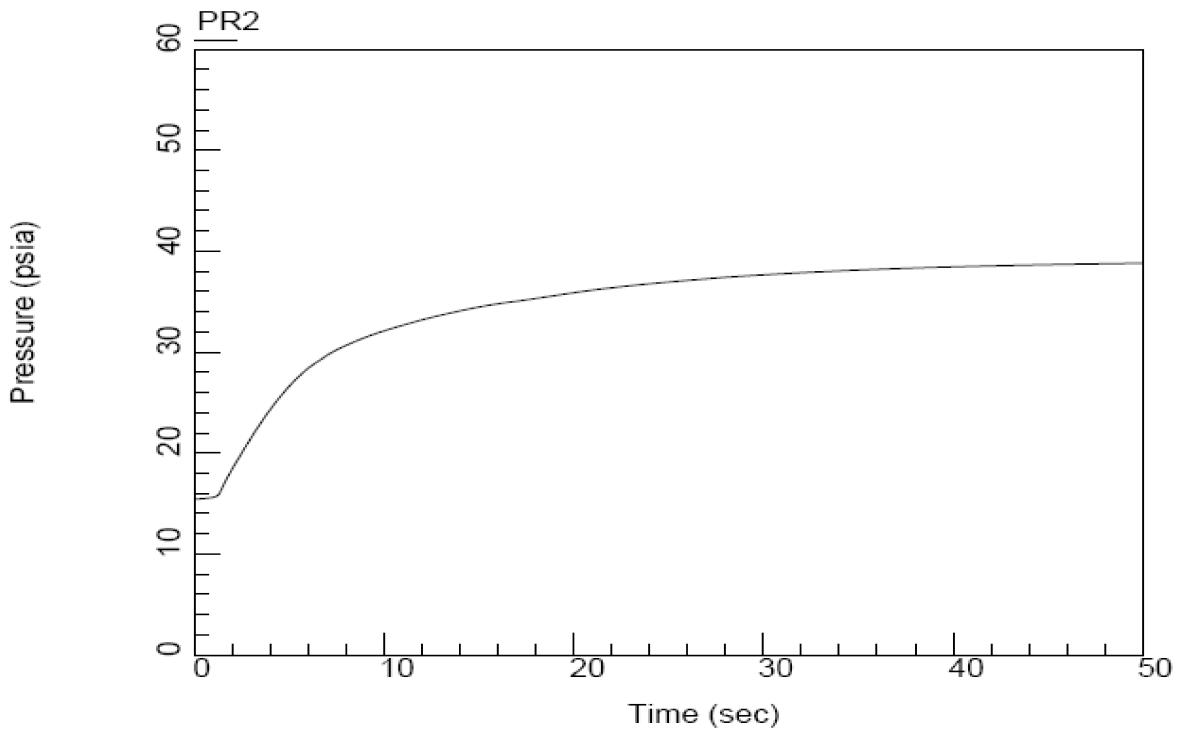

Figure 6.2-12b Wetwell Pressure Time History for MSLB

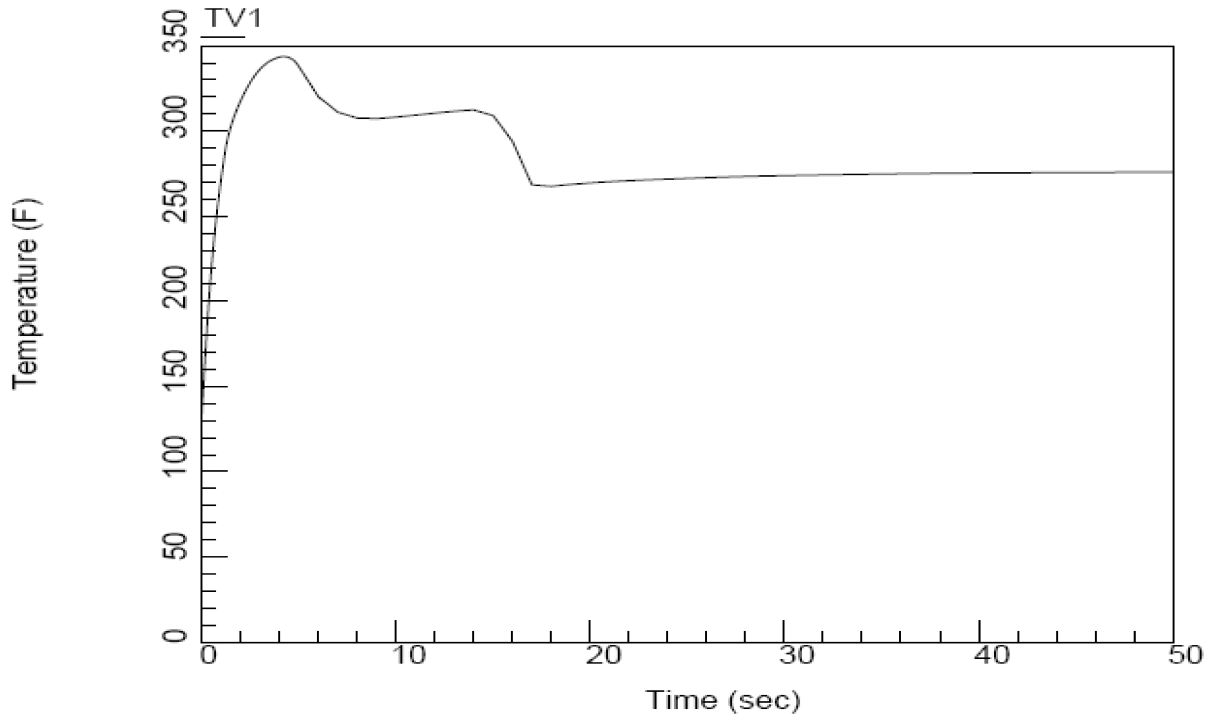

Figure 6.2-13a Drywell Temperature Time History for MSLB

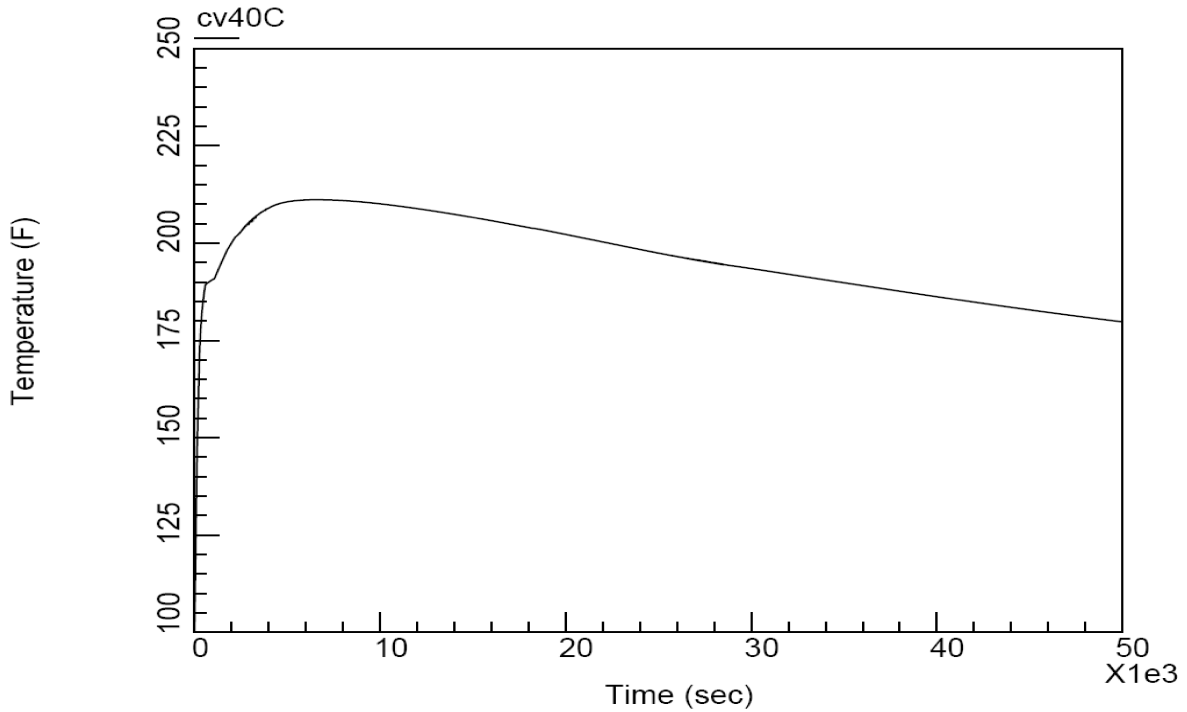

Figure 6.2-13b Suppression Pool Temperature Time History for MSLB

Figure 6.2-14 ~~Pressure Time History for MSLB with Two Phase Blowdown Starting at One Second~~Not Used

**Figure 6.2-15 ~~Temperature Time History for MSLB with Two Phase Blowdown~~  
~~Starting at One Second~~Not Used**



**Figure 6.2-22 ~~Break Flow Rate and Specific Enthalpy for the Feedwater Line Break Flow Coming from the Feedwater System Side~~ Not Used**

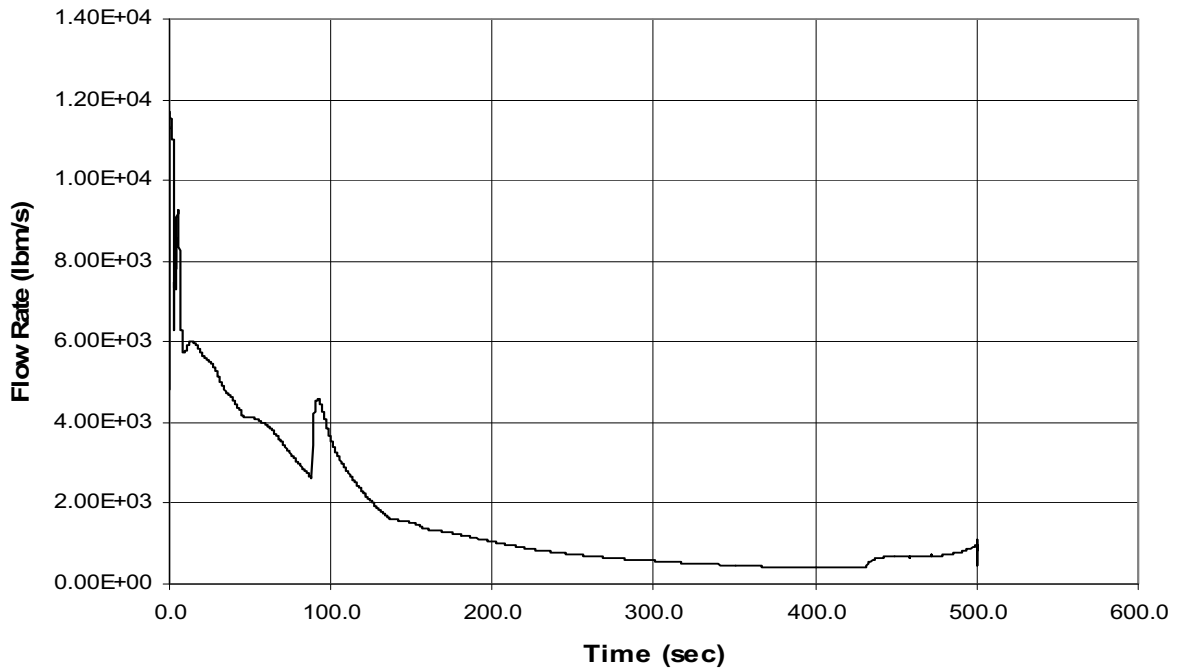

Figure 6.2-23a Break Flow Rate for the Feedwater Line Break Flow coming from the RPV Side

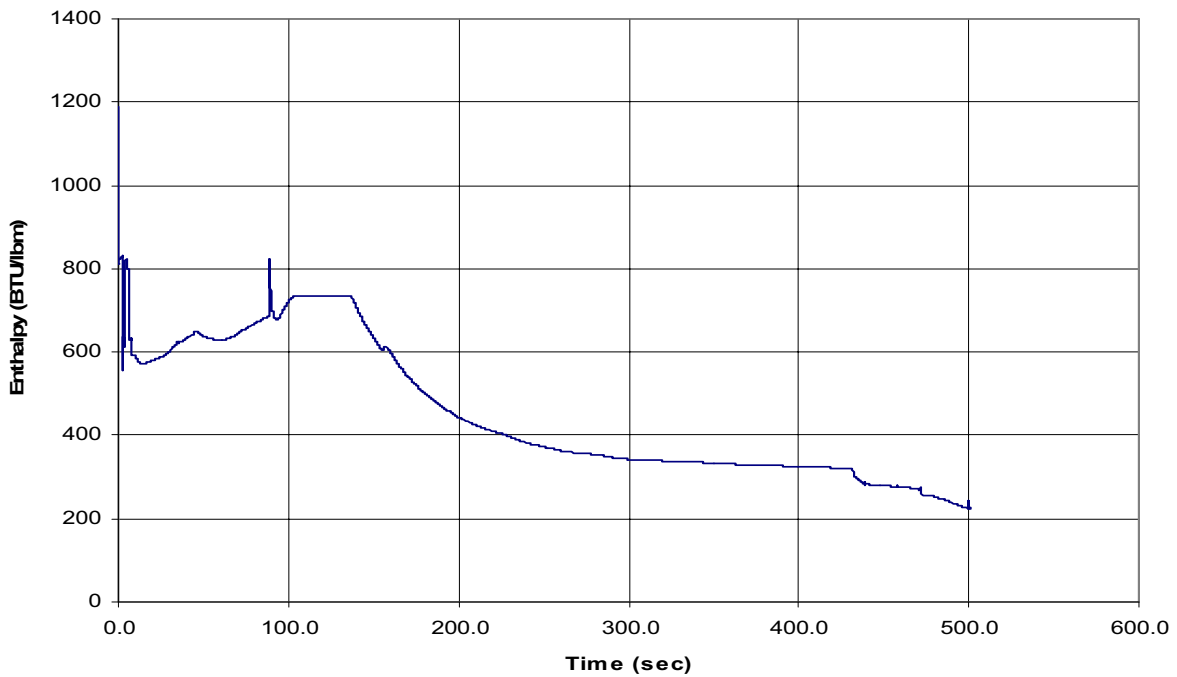

Figure 6.2-23b Break Flow Specific Enthalpy for the Feedwater Line Break Flow coming from the RPV Side

**Figure 6.2-24 ~~Break Flow Rate and Specific Enthalpy for the Main Steamline Break with Two Phase Blowdown Starting When the Collapsed Water Level Reaches the Steam Nozzle~~Not Used**

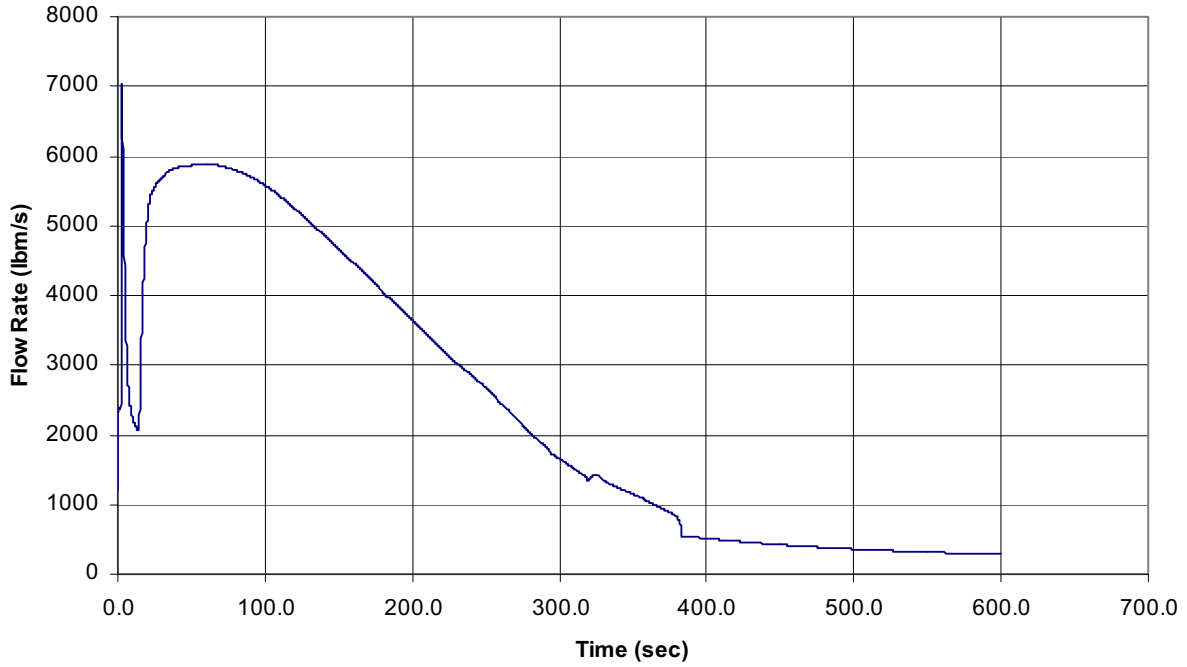

Figure 6.2-25a MSLB Short Term Break Flow (RPV Side)

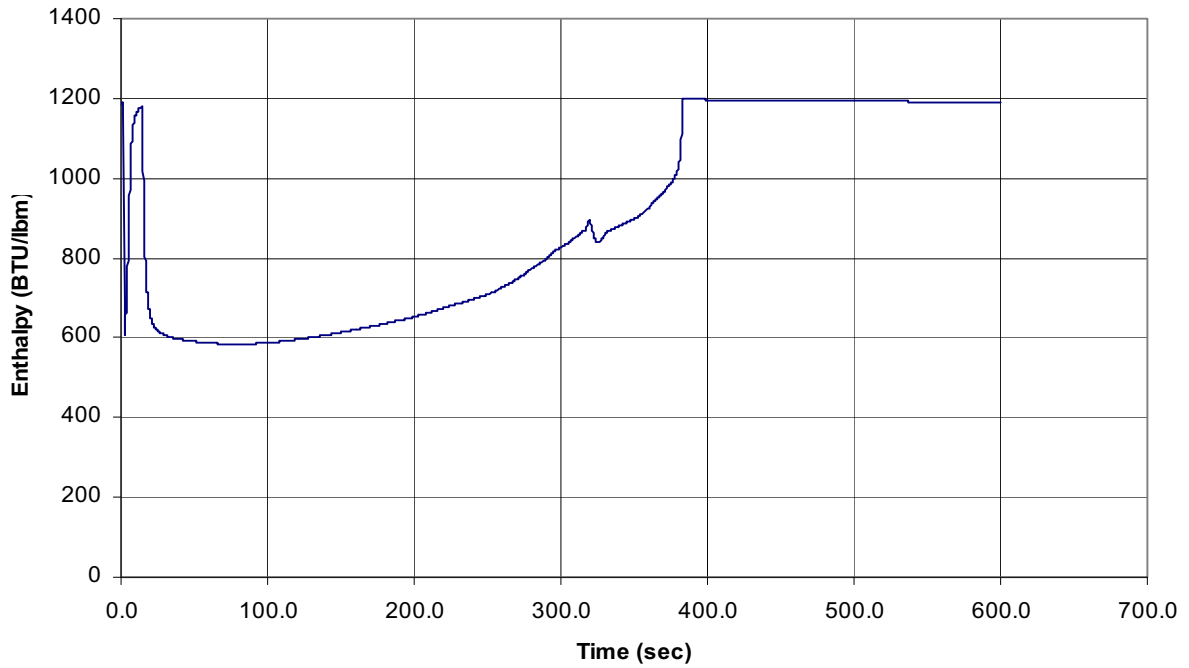

Figure 6.2-25b MSLB Short Term Break Flow (RPV Side)

Figures 6.2-38, 6.2-39, and 6.2-40 are revised and are located in Chapter 21:

Figure 6.2-38 Plant Requirements, Group Classification and Containment Isolation Diagram (Sheets 1 – 2)

STD DEP T1 2.4-3

The alternate RCIC design eliminates the barometric condenser and discharge piping to the containment.

STD DEP T1 2.14-1

The FCS is eliminated in accordance with NRC rules and regulations.

STD DEP 9.3-2

This departure uses an existing spare containment penetration for the Breathing Air System. The breathing air line has a manually operated valve inside the containment and a manually operated valve outside containment which will be closed during normal operation.

Figure 6.2-40 ~~Flammability Control System P&ID ( Sheets 1-2)~~ **Not Used**

STD DEP T1 2.14-1

The FCS is eliminated in accordance with NRC rules and regulations.

**Figure 6.2-41 ~~Hydrogen and Oxygen Concentrations in Containment After Design Basis LOCA~~Not Used**