

From: [Sheron, Brian](#)
To: [Shane, Raeann](#)
Subject: FW: Answers to questions from Congressional Call
Date: Friday, March 25, 2011 2:13:00 PM
Attachments: [Answers to 4 questions from Brian Sheron from Congressional Call.docx](#)
[TI Objectives.docx](#)

Here is a cleaner version.

From: LIA02 Hoc
Sent: Friday, March 25, 2011 1:56 PM
To: Sheron, Brian
Cc: McGinty, Tim; Nelson, Robert; LIA06 Hoc; LIA03 Hoc; LIA08 Hoc; Smith, Brooke; Foggie, Kirk
Subject: Answers to questions from Congressional Call

Brian,

The responses to the questions are attached. The first file contains the answers and the second file contains a TI referenced in the answer to question 4.

Steve

CH/376

- 1.) Two workers were reported to have been hospitalized due to radiation exposure. Have there been any more workers hospitalized, and do we know how they were exposed?
- 2.) Three workers were reported to have received radiation burns to their feet by spending too much time walking in contaminated water. Do we have any more information on this?

The following information taken from the IAEA website and answers these two questions:

As per the IAEA, three workers at the Fukushima Daiichi nuclear power plant were exposed on 24 March to elevated levels of radiation. The IAEA has received additional information on the incident from the Japanese authorities.

The three were contracted workers laying cables in the turbine building of the Unit 3 reactor. Two of them were found to have radioactivity on their feet and legs.

These were washed in the attempt to remove radioactivity, but since there was a possibility of Beta-ray burning of the skin, the two were taken to the Fukushima University Hospital for examination and then transferred to Japan's National Institute of Radiological Sciences for further examination. They are expected to be monitored for around four days.

It is thought that the workers ignored their dosimeters' alarm believing it to be false and continued working with their feet in contaminated water.

The Nuclear and Industrial Safety Agency (NISA) of Japan instructed TEPCO to review the radiation control system immediately in order to avoid similar incidents in the future.

As of 24 March, 19:30 Japan time, the number of workers at the Fukushima Daiichi nuclear power plant found to have received more than 100 millisieverts of radiation dose totalled 17 including the three contract workers. The remaining fourteen are TEPCO's employees.

- 3.) It was reported that the iodine levels in the Tokyo drinking water went down below allowable limits. Do we know what this is attributable to? Was it due to a shift in wind direction? Did the releases from the plant go down"?

No quantitative cause analysis exists, but decay of iodine itself or reduction in rainfall with iodine, or their combination can be a plausible reason.

- 4.) What action is the NRC taking regarding licensee plans to walk down their plants to confirm systems, procedures, etc., are in place to deal with natural phenomena? Are the resident inspectors going to accompany the licenses during the walkdowns?

The TI (issued March 23, 2011) has inspectors verify that the licensees have performed walkdowns. This can be done in various ways. For example the inspector could walkdown the system with the licensee or perform an independent walkdown and compare those results with the licensee's results (or a combination of both). In some cases the inspector may choose to just review the licensee's documentation of findings from the walkdown.

For more information on the TI a one page set of talking points is attached.

Overview of TI 2515/183, "FOLLOWUP TO THE FUKUSHIMA DAIICHI NUCLEAR STATION
FUEL DAMAGE EVENT"

March 23, 2011

TI Objectives

- The objective of this TI is a high-level, independent assessment, of the adequacy of actions taken by licensees in response to the Fukushima Daiichi nuclear station fuel damage event.
- The inspection results from this TI will be used to evaluate the industry's readiness for a similar event and to aid in determining whether additional regulatory actions warranted.

TI Focus Areas

1. Assess the licensee's capability to mitigate conditions that result from beyond design basis events (e.g., B.5.b and 10 CFR 50.54(hh)).
2. Assess the licensee's capability to mitigate station blackout (SBO) conditions, as required by 10 CFR 50.63.
3. Assess the licensee's capability to mitigate internal and external flooding events required by station design.
4. Assess the thoroughness of the licensee's walkdowns and inspections of important equipment needed to mitigate fire and flood events to identify the potential that the equipment's function could be lost during seismic events possible for the site.

TI Inspection Methods

- Use existing inspection procedures and TIs for guidance
- Where applicable, inspectors should credit the baseline inspection program for samples reviewed during this TI assessment.
- Resources: 40 hours per site.

Other Issues

- The TI was issued on March 23, 2011. Each site will complete the inspection by April 29, 2011 and issue a stand-alone report by May 13, 2011
- An inspection report template is being prepared (and should be available mid-next week) to assist in documentation.
- The short inspection and documentation timeline could have a significant impact on regional resources.

From: Per F. Peterson
To: Cherry, Ronald C; Aoki, Steven
Cc: Brinkman, Bill; Hurlbut, Brandon; Sheron, Brian; Poneman, Daniel; "harold.mcfarlane@inl.gov"; Adams, Ian; (b)(6); Kelly, John E (NE); "john.grossenbacher@inl.gov"; Owens, Missy; "peter.soumeuc@pers.evry.edu"; Lyons, Peter; "phillip.finck@inl.gov"; (b)(6); "P.Budoitz@inl.gov"; "ronaldo.szilard@inl.gov"; SCHU; Aoki, Steven; Koonin, Steven; (b)(6); DAgostino, Thomas
Subject: Re: Question about GOJ Thyroid Screening
Date: Friday, March 25, 2011 2:13:04 PM

Ron and Steve,

Thank you. It is very helpful to know that the Japanese health authorities are making these these measurements for radioiodine uptake to children and the committed doses associated with these uptakes.

It is impressive that the maximum dose measured is 0.24 micro-sievert (0.024 mR) in a 12-year old boy, presuming that this reporting is correct. This is far below the level needed to cause any detectable health effects.

The aim of U.S. protective action guidelines is to administer potassium iodine (KI) if thyroid doses to adults are expected to exceed 15,000 mR and to infants if doses are expected to exceed 5000 mR, so actual maximum exposures being measured in Japan in children living near the plant are 5 orders of magnitude below levels that would trigger a decision the use of KI (although KI may still have been used for children living this close the the plant, and if so could contribute to the fact that measured doses are very low). It is clearly very reassuring to learn what the actual thyroid doses are that are being measured in Japan.

I would certainly recommend to the Japanese health authorities to expand their survey efforts to include areas further away from Fukushima, including Tokyo, and to continue these measurements over the next 2 months so that there is sufficient data available to come back later and assess in detail how effective current protective action guidelines are, and also to confirm that there are no gaps in the current PAGs.

Again, it is important to emphasize that there exists only a limited time window during which useful exposure data can be collected, due to the short half life of I-131.

It would be very helpful for us to know what methods the Japanese health authorities are using for their measurements. As you know, we have detected small concentrations of I-131 and other radioactive materials in rainwater in Berkeley over this last week. I am now working with faculty in our school of public health to see how we can make similar measurements to verify what exposures have occurred.

I do believe that these measurements will be very important in the longer term in assessing the consequences of the Fukushima accident. Your help in transferring the recommendation that expanded measurements be made, and to obtain information on the methods being used for these measurements, is greatly appreciated.

-Per

CH/377

Steve,

Steve, In your earlier email you asked whether Japan had begun thyroid testing. Looks like the answer is yes. DART Health and Safety officer pointed out a news article reported by the Embassy Task Force, which I've pasted immediately below.

Hope this helps.

Ron

08:43 March 25, 2011 Friday (Jiji: Fukushima children's thyroid gland radiation exposure within safe levels): Jiji Press Online reported at 04:51 that the government's nuclear disaster response headquarters announced before dawn on Mar 25 that an examination of 66 children, aged 1-15, from Namie town, Minami-Soma city, Iitate village, and Kawamata town for thyroid gland exposure to radiation showed that radiation levels in all children was below the safety level set by the Nuclear Safety Commission of 2 micro-sieverts per hour, with the highest level of 0.24 micro-sievert recorded in a 12-year old boy. The children are all currently living in Kawamata town, 35-50kms from the Fukushima Daiichi plant.

SBU

This email is UNCLASSIFIED.

From: Hughart, Joseph (FOH) [mailto:Joseph.Hughart@foh.hhs.gov]
Sent: Friday, March 25, 2011 11:06 AM
To: Cherry, Ronald C
Subject: FW: 10:00 March 25 Running Update on Japan Emergency (with running file attached)

Ron, in the thread below is a report that Japanese government officials

are conducting thyroid screening for iodine burdens. For your friends who are inquiring about the issue.

Best,

- Joe Hughart

CAPT USPHS

HHS PSC FOHS

404-667-5905

joseph.hughart@foh.hhs.gov

--

Per F. Peterson
Professor and Chair
Department of Nuclear Engineering
University of California
4153 Etcheverry Hall
Berkeley, California 94720-1730
peterson@nuc.berkeley.edu
Office: (510) 643-7749 Fax: (510) 643-9685
http://www.nuc.berkeley.edu/People/Per_Peterson

From: [Shane, Raeann](#)
To: [Sheron, Brian](#)
Subject: RE: Answers to questions from Congressional Call
Date: Friday, March 25, 2011 2:13:39 PM

Thanks!

From: Sheron, Brian
Sent: Friday, March 25, 2011 2:13 PM
To: Shane, Raeann
Subject: FW: Answers to questions from Congressional Call

Here is a cleaner version.

From: LIA02 Hoc
Sent: Friday, March 25, 2011 1:56 PM
To: Sheron, Brian
Cc: McGinty, Tim; Nelson, Robert; LIA06 Hoc; LIA03 Hoc; LIA08 Hoc; Smith, Brooke; Foggie, Kirk
Subject: Answers to questions from Congressional Call

Brian,

The responses to the questions are attached. The first file contains the answers and the second file contains a TI referenced in the answer to question 4.

Steve

CH/378

From: Riley (OCA), Timothy
To: Sheron, Brian
Subject: OCA call 3/25
Date: Friday, March 25, 2011 2:41:02 PM

Dr. Sheron,

I'll be the call leader today for the Hill call at 3pm. Thank you for sending us the answers from yesterday's info requests, I sent them to yesterday's participants.

I'll be calling from the EOC and will talk with you soon.

Thank you for supporting OCA by giving your time to this call,

Tim Riley

CH/379

From: Weber, Michael
To: Wiggins, Jim; Sheron, Brian; Evans, Michele
Cc: Virgilio, Martin; McDermott, Brian; Borchart, Bill; Zimmerman, Roy; Uhle, Jennifer; ET01 Hoc; LIA06 Hoc; LIA08 Hoc; OST02 HOC
Subject: Response - Japanese Earthquake 24 March 2011 1800 EDT Situation Report
Date: Friday, March 25, 2011 2:44:51 PM

(b)(5)

----- Original Message -----

From: Wiggins, Jim
To: Sheron, Brian; Evans, Michele
Cc: Weber, Michael; Virgilio, Martin; McDermott, Brian
Sent: Fri Mar 25 08:22:45 2011
Subject: RE: Response - Japanese Earthquake 24 March 2011 1800 EDT Situation Report

(b)(5)

Thoughts?

-----Original Message-----

From: Sheron, Brian
Sent: Friday, March 25, 2011 8:16 AM
To: Wiggins, Jim; Evans, Michele
Subject: FW: Response - Japanese Earthquake 24 March 2011 1800 EDT Situation Report

See below. If you agree, do you want to initiate a contact with the DOE IRC for the purpose of coordinating Sitreps so the info coming out of the NRC and DOE is consistent and not conflicting?

-----Original Message-----

From: Sheron, Brian
Sent: Friday, March 25, 2011 8:09 AM
To: Weber, Michael
Cc: Dyer, Jim; LIA06 Hoc; LIA08 Hoc
Subject: RE: Response - Japanese Earthquake 24 March 2011 1800 EDT Situation Report

Mike, the DOE Science Council that I participate on is not the group that puts out the DOE Situation Report. On the last page of the DOE Sitrep, it says it is put out by their Nuclear Incident team in the DOE's Emergency Operations Center. The e-mail is NITOPS@NNSA.DOE.GOV and the phone is 202-586, 8100. I would suggest that the NRC's IRC contact the DOE IRC and come up with a way to put out a combined Sitrep.

Do you want to direct the appropriate folks in the IRC to initiate a contact with the DOE IRC for the purpose of coordinating the Sitreps, or I can call Jim W. or Michele E. and ask.

-----Original Message-----

From: Weber, Michael
Sent: Friday, March 25, 2011 8:00 AM
To: Sheron, Brian

CH/380

Cc: Dyer, Jim; LIA06 Hoc; LIA08 Hoc
Subject: Response - Japanese Earthquake 24 March 2011 1800 EDT Situation Report

Thanks, Brian. On the next call, can you suggest that we and DOE collaborate on issuing a combined situation report with consistent information? I see that their distribution is broader and includes local government contacts (e.g., Montgomery County, Maryland).

----- Original Message -----

From: Sheron, Brian
To: HOO Hoc
Cc: Weber, Michael; Virgilio, Martin
Sent: Fri Mar 25 07:12:29 2011
Subject: FW: UPDATED: Japanese Earthquake 24 March 2011 1800 EDT Situation Report

Please forward to ET, RST, & PMT Directors. Thx.

-----Original Message-----

From: Adams, Ian [<mailto:Ian.Adams@Hq.Doe.Gov>]
Sent: Thursday, March 24, 2011 7:23 PM
To: Adams, Ian; Aoki, Steven; Binkley, Steve; Brinkman, Bill; Budnitz, Bob; Finck, Phillip; Garwin, Dick (EOP); Garwin, Dick (IBM); Grossenbacher, John (INL); Hurlbut, Brandon; John Holdren; Kelly, John E (NE); Koonin, Steven; Lyons, Peter; McFarlane, Harold; Miller, Neile; Mustin, Tracy; Owens, Missy; Peterson, Per; Sheron, Brian; Steve Fetter; Szilard, Ronalo
Subject: FW: UPDATED: Japanese Earthquake 24 March 2011 1800 EDT Situation Report

Good evening,

Attached is the latest Japan Sit Rep.

This information should not be shared or further distributed.

-----Original Message-----

From: NITOPS
Sent: Thursday, March 24, 2011 7:17 PM

To: (b)(6)
(b)(7)



(b)(6)

Subject: UPDATED: Japanese Earthquake 24 March 2011 1800 EDT Situation Report

Attached is an updated 24 March 1800 SITREP file. The original 1800 SITREP incorrectly reported that the radiation level at the main gate at Fukushima Dai-ichi (approximately 3281 feet from the Unit 2 building) was 204.5 mSv/hr vice the correct level of 204.5 micro Sv/hr.

Nuclear Incident Team (NIT)
Office of Emergency Response (NA-42)
National Nuclear Security Administration U.S. Department of Energy nitops@nnsa.doe.gov
nit@doe.gov 202-586-8100

From: Per F. Peterson
To: Cherry, Ronald C; Aoki, Steven
Cc: Brinkman, Bill; Hurlbut, Brandon; Sheron, Brian; Poneman, Daniel; "harold.mcfarlane@inl.gov"; Adams, Ian; (b)(6) Kelly, John E (NE); "john.grossenbacher@inl.gov"; Owens, Missy; "peterson@nuc.berkeley.edu"; Lyons, Peter; "phillip.finck@inl.gov"; (b)(6) "RJBudnitz@inl.gov"; "ronaldo.szilard@inl.gov"; SCHU; Aoki, Steven; Koonin, Steven; (b)(6) Agostino, Thomas
Subject: Fwd: Re: Question about GOJ Thyroid Screening
Date: Friday, March 25, 2011 2:45:44 PM

A correction.

The units in the article below are micro-sieverts per hour (I was confused because the second time the dose was listed, it was not listed as a dose rate, but from context it clearly is).

In this case, the the total committed dose is higher.

If I have done my math correctly, for a 8-day half life, the integrated dose out to infinite time for the thyroid is

$$\text{TEDE} = (0.24 \text{ micro-sievert/hr})(277 \text{ hr}) = 66 \text{ microsievert} = 6.6 \text{ mR.}$$

This is two orders of magnitude lower than the TEDE at which the administration of KI is indicated. It is possible that these children were administered KI, in which case doses would have been higher due to greater uptake of I-131 in the thyroids.

This dose is still be well below the level at which any detectable health effects could be expected. The value of having this data clearly argues for an expanded effort to collect data from locations further away from Fukushima, over the next 2 months.

-Per

Date: Fri, 25 Mar 2011 11:12:54 -0700

To: "Cherry, Ronald C" <CherryRC@state.gov>,

"Aoki, Steven" <Steven.Aoki@nnsa.doe.gov>

From: "Per F. Peterson" <peterson@nuc.berkeley.edu>

Subject: Re: Question about GOJ Thyroid Screening

Ron and Steve,

Thank you. It is very helpful to know that the Japanese health authorities are making these these measurements for radioiodine uptake to children and the committed doses associated with these uptakes.

CH/381

It is impressive that the maximum dose measured is 0.24 micro-sievert (0.024 mR) in a 12-year old boy, presuming that this reporting is correct. This is far below the level needed to cause any detectable health effects.

The aim of U.S. protective action guidelines is to administer potassium iodine (KI) if thyroid doses to adults are expected to exceed 15,000 mR and to infants if doses are expected to exceed 5000 mR, so actual maximum exposures being measured in Japan in children living near the plant are 5 orders of magnitude below levels that would trigger a decision the use of KI (although KI may still have been used for children living this close to the plant, and if so could contribute to the fact that measured doses are very low). It is clearly very reassuring to learn what the actual thyroid doses are that are being measured in Japan.

I would certainly recommend to the Japanese health authorities to expand their survey efforts to include areas further away from Fukushima, including Tokyo, and to continue these measurements over the next 2 months so that there is sufficient data available to come back later and assess in detail how effective current protective action guidelines are, and also to confirm that there are no gaps in the current PAGs.

Again, it is important to emphasize that there exists only a limited time window during which useful exposure data can be collected, due to the short half life of I-131.

It would be very helpful for us to know what methods the Japanese health authorities are using for their measurements. As you know, we have detected small concentrations of I-131 and other radioactive materials in rainwater in Berkeley over this last week. I am now working with faculty in our school of public health to see how we can make similar measurements to verify what exposures have occurred.

I do believe that these measurements will be very important in the longer term in assessing the consequences of the Fukushima accident. Your help in transferring the recommendation that expanded measurements be made, and to obtain information on the methods being used for these measurements, is greatly appreciated.

-Per

Steve,

Steve, In your earlier email you asked whether Japan had begun thyroid testing. Looks like the answer is yes. DART Health and Safety officer pointed out a news article reported by the Embassy Task Force, which I've pasted immediately below.

Hope this helps.

Ron

08:43 March 25, 2011 Friday (Jiji: Fukushima children's thyroid gland radiation exposure within safe levels): Jiji Press Online reported at 04:51 that the government's nuclear disaster response headquarters announced before dawn on Mar 25 that an examination of 66 children, aged 1-15, from Namie town, Minami-Soma city, Iitate village, and Kawamata town for thyroid gland exposure to radiation showed that radiation levels in all children was below the safety level set by the Nuclear Safety Commission of 2 micro-sieverts per hour, with the highest level of 0.24 micro-sievert recorded in a 12-year old boy. The children are all currently living in Kawamata town, 35-50kms from the Fukushima Daiichi plant.

SBU

This email is UNCLASSIFIED.

From: Hughart, Joseph (FOH)
[mailto:Joseph.Hughart@foh.hhs.gov]

Sent: Friday, March 25, 2011 11:06 AM
To: Cherry, Ronald C
Subject: FW: 10:00 March 25 Running Update on Japan
Emergency (with running file attached)

Ron, in the thread below is a report that Japanese government officials are conducting thyroid screening for iodine burdens. For your friends who are inquiring about the issue.

Best,

- Joe Hughart

CAPT USPHS

HHS PSC FOHS

404-667-5905

joseph.hughart@foh.hhs.gov

--

Per F. Peterson
Professor and Chair
Department of Nuclear Engineering
University of California
4153 Etcheverry Hall
Berkeley, California 94720-1730
peterson@nuc.berkeley.edu
Office: (510) 643-7749 Fax: (510) 643-9685
http://www.nuc.berkeley.edu/People/Per_Peterson

--

Per F. Peterson
Professor and Chair

Department of Nuclear Engineering
University of California
4153 Etcheverry Hall
Berkeley, California 94720-1730
peterson@nuc.berkeley.edu
Office: (510) 643-7749 Fax: (510) 643-9685
http://www.nuc.berkeley.edu/People/Per_Peterson

From: Sheron, Brian
To: HOO Hoc
Subject: FW: Reactor Safety Team Assessment 2000 EDT 3-24-2011
Date: Friday, March 25, 2011 2:56:00 PM
Attachments: 03-24-11 2000 RST Assessment Document.docx

Please ask the RST whether they agree with the DOE report regarding freshwater being injected for core cooling in unit one. Thanks.

From: Kelly, John E (NE) [mailto:JohnE.Kelly@Nuclear.Energy.Gov]
Sent: Friday, March 25, 2011 1:50 PM
To: DL-NITsolutions
Subject: FW: Reactor Safety Team Assessment 2000 EDT 3-24-2011

Integrated DOE-NRC-INPO report to Japan

From: Versluis, Rob
Sent: Thursday, March 24, 2011 10:28 PM
To: DL-NERT-All
Subject: Fw: Reactor Safety Team Assessment 2000 EDT 3-24-2011

Fyi
Rob Versluis +1-301-903-1890(o) (b)(6) (m)

From: RST01 Hoc <RST01.Hoc@nrc.gov>
To: RST01 Hoc <RST01.Hoc@nrc.gov>; RST02 Hoc <RST02.Hoc@nrc.gov>; mossdj@inpo.org <mossdj@inpo.org>; Casto, Chuck <Chuck.Casto@nrc.gov>; Nakanishi, Tony <Tony.Nakanishi@nrc.gov>; Monninger, John <John.Monninger@nrc.gov>; Devercelly, Richard <Richard.Devercelly@nrc.gov>; Foster, Jack <Jack.Foster@nrc.gov>; Trapp, James <James.Trapp@nrc.gov>
Cc: RST03 Hoc <RST03.Hoc@nrc.gov>; INPOERCAssistance <INPOERCAssistance@inpo.org>; Ruland, William <William.Ruland@nrc.gov>; Versluis, Rob
Sent: Thu Mar 24 22:25:22 2011
Subject: Reactor Safety Team Assessment 2000 EDT 3-24-2011

All,

The reactor safety team has compiled its assessment report of conditions and recommendations at the damaged Fukushima Daiichi reactor plants.

Shortly after our completion of the attached report, the RST received a new update from JAIF with a time-date stamp of 2200 JDT 3/24/2011 (0900 EDT 3/24/2011), that indicates changes in their view of containment integrity in units One and Three, indicating the containment vessel integrity status as "Not Damaged". This information has not been factored into the assessment report, and the RST will be moving forward to review and evaluate this latest status report.

CA/382

We request that our INPO addressee please forward this assessment to the EPRI staff who are involved in this event response activity.

If you have any comments or questions on this report, please contact the Reactor Safety Team at RST01.Hoc@nrc.gov.

John Thorp
RST Chronologist Evening Shift, 3/24/2011

From: Sheron, Brian
To: Kardaras, Tom; Valentin, Andrea
Subject: RE: Men's Room handicap Stall
Date: Friday, March 25, 2011 3:01:00 PM

Thanks.

From: Kardaras, Tom
Sent: Friday, March 25, 2011 2:56 PM
To: Sheron, Brian; Valentin, Andrea
Subject: RE: Men's Room handicap Stall

Brian,

This was not previously reported and I just called our ADM POC and requested to have the repair expedited. I also issued a FIXIT request. The toilet is not flushing properly.

Regards,
Tom Kardaras, Deputy Director (Acting)
Program Management, Policy Development and Analysis Staff
Office of Nuclear Regulatory Research
(o) 301-251-7667

From: Sheron, Brian
Sent: Friday, March 25, 2011 1:34 PM
To: Valentin, Andrea; Kardaras, Tom
Subject: Men's Room handicap Stall

Has had an "Out of order" sign on it for over a week. Do we know if it has been reported, and do we know why it is taking so long to fix?

CH/383

From: Schaperow, Jason
To: Sheron, Brian
Cc: Gibson, Kathy
Subject: Question from House staffers
Date: Friday, March 25, 2011 3:03:26 PM

Hi Brian,

Regarding a question that the House staffers (Jeff Baran, Allison Cassidy) asked us today at 2:00...

I found on the NRC external web site the report they asked about. The report is NUREG/CR-6920, "Risk-Informed Assessment of Degraded Containment Vessels." The project manager was Herman Graves (RES/DE) and the Sandia analysts were Spencer, Petti, and Kunsman. Jose Pires (RES/DE) may have been involved in this work as well. The following is a link to the document:

<http://www.nrc.gov/reading-rm/doc-collections/nuregs/contract/cr6920/>

Would you like me to ask Herman or Jose to come see you about this?

Thanks,
Jason

CH/384

From: Sheron, Brian
To: HOO Hoc
Cc: Weber, Michael; Virgilio, Martin
Subject: Congressional Questions
Date: Friday, March 25, 2011 3:36:00 PM

Can you please pass these questions to the ET.

- 1.) During the Congressional call a few minutes ago, I was asked what the NRC's priorities were. From the March 25th, 0430 EDT status update, I said that Unit 1 was priority #1, unit 2 was priority #2, unit 3 was priority #3, and unit 4 was priority #4. I was asked why our priorities had changed from 3/24, when the status update listed unit 1 as priority #4, unit 2 as priority #3, unit 3 as priority #1, and unit 4 as priority #2. The status update reports provide no explanation for the changes. Hence, I had to promise to get back to them with an answer.
 - a.) Can the RST and/or PMT provide me with an explanation of why we changed our priorities from yesterday for all of the 4 units?
 - b.) For future reference, it would be helpful for the status update report to provide explanations when changes like these are made.
- 1.) One of the congressional staffers said that there was water in the basement of the reactor building (she said this was the contaminated water that 3 workers were walking in and reportedly got radiation burns to their feet). She asked if we knew where it came from. I believe she wanted to know if it was primary coolant water, and if so, how was it getting out of the primary system, since we are reporting that the primary containment remains functional. I said I had heard reports that it may have been SFP water that sloshed out during the earthquake, but did not know for sure. Does anyone in the RST know where this water may have come from? Do we have any idea if the primary system has been breached, and if so, what potential pathways, if any exist for primary water to get into the basement of the reactor building?

CH/385

From: [Hudson, Daniel](#)
To: [Bowman, Gregory](#)
Cc: [Coyne, Kevin](#); [Coe, Doug](#); [Correia, Richard](#); [Gibson, Kathy](#); [Uhle, Jennifer](#); [Sheron, Brian](#)
Subject: RESPONSE: Draft Level 3 PRA Commission Meeting Scheduling Note
Date: Friday, March 25, 2011 3:39:23 PM
Attachments: [Draft Level 3 PRA Commission Meeting Scheduling Note 03252011.docx](#)

Greg,

As requested, we have revised the draft Level 3 PRA Commission Meeting scheduling note to address the Chairman's feedback regarding the removal of SOARCA and the addition of an external panel and a severe accidents topic. The revised draft is attached for your review.

Please note that NEI has not yet identified a specific individual that SECY could invite to participate in the external panel, should the Commission determine that NEI will be invited to participate. I will provide you with an update as more information becomes available.

Please let me know if you have any questions, comments, or concerns.

Best regards,
Dan

Daniel W. Hudson
Technical Assistant
U.S. Nuclear Regulatory Commission
Office of Nuclear Regulatory Research
Division of Risk Analysis
Daniel.Hudson@nrc.gov
301-251-7919

CH/386

SCHEDULING NOTE

Title: **BRIEFING ON SEVERE ACCIDENTS AND OPTIONS FOR PROCEEDING WITH LEVEL 3 PROBABILISTIC RISK ASSESSMENT ACTIVITIES (Public)**

Purpose: To provide the Commission a discussion of severe accidents and options for proceeding with Level 3 probabilistic risk assessment (PRA) activities and to facilitate Commission voting on the notation vote policy issue SECY paper that will include the staff's recommendation regarding whether and how to proceed with Level 3 PRA activities.

Scheduled: **Month, Date, Year [SECY will fill in]
Time [SECY will fill in]**

Duration: Two hours

Location: Commissioners' Conference Room, 1st floor OWFN [SECY will change if needed]

Participants:	Presentation
<u>External Panel</u>	20 mins.*
TBD , Nuclear Energy Institute (Tentative) <u>Topic:</u> Perspectives on Future Level 3 PRAs	10 mins.*
Stuart Lewis , Program Manager for Risk and Safety Management, Electric Power Research Institute, Inc. <u>Topic:</u> Perspectives on Future Level 3 PRAs	10 mins.*
Commission Q & A	20 mins.
Break	5 mins.
<u>NRC Staff Panel</u>	35 mins.*
Bill Borchardt , Executive Director for Operations Brian Sheron , Director, RES <u>Topic:</u> Introduction and Overview of Severe Accidents	10 mins.*
Daniel Hudson , Level 3 PRA Project Manager, RES <u>Topic:</u> Proposed Level 3 PRA Activities	25 mins.*

Additional staff available to answer questions if needed:

- **Charles Tinkler**, Senior Advisor for Severe Accident Phenomenology Code Development and Analysis, RES
- **Martin Stutzke**, Senior Technical Advisor for PRA Technology, RES

Commission Q & A **35 mins.**

Discussion – Wrap-up **5 mins.**

*For presentation only and does not include time for Commission Q & A's.

Documents:

Staff background material due to SECY: Ten business days prior to the meeting.
[SECY to fill in date]

Slides due to SECY: Five business days prior to the meeting. [SECY to fill in date]

From: [Sheron, Brian](#)
To: [Bonaccorso, Amy](#); [Calvo, Antony](#); [Case, Michael](#); [Coe, Doug](#); [Correia, Richard](#); [Dion, Jeanne](#); [Gibson, Kathy](#); [Lui, Christiana](#); [Richards, Stuart](#); [Rini, Brett](#); [Sanquimino, Donna-Marie](#); [Uhle, Jennifer](#); [Valentin, Andrea](#)
Subject: FW: OIP Weekly
Date: Friday, March 25, 2011 3:40:00 PM
Attachments: [OIP Weekly News 3-28-2011.docx](#)

From: Kreuter, Jane
Sent: Friday, March 25, 2011 2:59 PM
To: Abogunde, Maryann; Abrams, Charlotte; Adler, James; Afshar-Tous, Mugeh; Apostolakis, George; Armstrong, Janine; Ash, Darren; Astwood, Heather; Baker, Stephen; Barkley, Richard; Barrett, Andy; Batkin, Joshua; Baval, Rochelle; Bergman, Thomas; Bloom, Steven; Boger, Bruce; Borchardt, Bill; Bozin, Sunny; Bradford, Anna; Brenner, Eliot; Bubar, Patrice; Burns, Stephen; Burris, Steve; Carter, Mary; Case, Michael; Casto, Chuck; Chimood, Jane; Coates, Carlotta; Coggins, Angela; Cool, Donald; Cullingford, Michael; DANDI_Calendar; Dapas, Marc; Davis, Roger; Dean, Bill; Decker, David; Dehn, Jeff; Dembek, Stephen; Diaz-Toro, Diana; Diec, David; Doane, Margaret; Dorman, Dan; Droggitis, Spiros; Dyer, Jim; Eisenberg, Wendy; Emche, Danielle; English, Lance; Essig, Thomas; Fehst, Geraldine; Fenstermacher, Amy; Ferkile, Andrea; Floyd, Daphene; Foggie, Kirk; Fragoyannis, Nancy; Franovich, Mike; Gibbs, Catina; Grobe, Jack; Hackett, Edwin; Haney, Catherine; Harris, Tim; Hayden, Elizabeth; Henderson, Karen; Herr, Linda; Hiltz, Thomas; Hirsch, Patricia; Holahan, Gary; Holahan, Patricia; Hopkins, Jon; Howell, Art; Hudson, Sharon; Jackson, Kia; Jaczko, Gregory; Jasinski, Robert; Johnson, Michael; Jones, Andrea; Jones, Cynthia; Kasputys, Clare; Killian, Michelle; Kim, Grace; Kock, Andrea; Kolb, Elaine; Kreuter, Jane; Layton, Michael; Leeds, Eric; Lisann, Elizabeth; Loyd, Susan; Lyons-Burke, Kathy; Magwood, William; Mamish, Nader; Matthews, David; Mayfield, Michael; Mayros, Lauren; McCree, Victor; McDevitt, Joan; Miller, Charles; Mitchell, Linda; Monninger, John; Moore, Scott; Morell, Gregory; Newell, Trenton; Nieh, Ho; Oliveto, Betsy; Ostendorff, William; Owens, Janice; Pace, Patti; Pangburn, George; Quinones, Lauren; Ramsey, Jack; Reyes, Luis; Rodriguez, Veronica; Rosales-Cooper, Cindy; Rothschild, Trip; Satorius, Mark; Schmidt, Rebecca; Schroer, Suzanne; Schwartzman, Jennifer; Shaffer, Mark; Sharkey, Jeffrey; Shepherd, Jill; Sheron, Brian; Skeen, David; Smirolodo, Elizabeth; Smith, Shawn; Smith, Wilkins; Sosa, Belkys; Speiser, Herald; Svinicki, Kristine; Vietti-Cook, Annette; Virgilio, Martin; Warren, Roberta; Weaver, Doug; Weber, Michael; Wiggins, Jim; Williams, Shawn; Wittick, Brian; Young, Francis; Zimmerman, Roy; Zorn, Jason
Subject: OIP Weekly

Have a Wonderful weekend! Stay warm!

Jane A. Kreuter
U.S. Nuclear Regulatory Commission
Office of International Programs
Phone: 301-415-1780
Fax: 301-415-2395
E-Mail: Jane.Kreuter@nrc.gov

CH/387

**INTERNATIONAL ITEMS OF INTEREST
OFFICE OF INTERNATIONAL PROGRAMS
Week of March 28, 2011**

OIP Vision: To expand nuclear safety and security worldwide through lasting partnerships.
Our Mission: OIP enhances nuclear safety and security through global partnerships by exchanging information and by licensing the import and export of material and equipment according to US laws and policy.

1. Commission Activities

Nothing to report

2. Export/Import Activities

Import and export license amendments (IW017/01 and XW010/01) were issued to Duratek Services, Inc. to extend their expiration dates to June 30, 2017 and December 31, 2017, respectively.

3. Conventions, Treaties, Legal Obligations and Interagency Activities

Nothing to report

4. Bilateral Activities

From March 27 to April 2, Michael Salay of RES will travel to Bergen, The Netherlands, to participate in the Phebus and Severe Accident Research NETWORK (SARNET) meetings where the latest test analyses and data will be obtained. He will provide NRC input and feedback on the Phebus-ISTP experiments, and will provide information on NRC's contribution to SARNET.

On March 29th Janice Owens from the Office of International Programs, along with Robin DeLaBarre of the State Department will meet with representatives from the United Arab Emirates' Ministry of Foreign Affairs to discuss export licensing requirements for minor reactor components. The meeting will be held at the State Department.

5. Multinational Activities

From March 26 to April 2, Kevin Coyne, Nathan Siu, and Gabriel Taylor of RES will travel to Paris, France. Kevin Coyne will serve as NRC's representative at the Working Group on Risk Assessment (WGRisk) Bureau and Annual Meetings where he will provide NRC's perspective regarding ongoing WGRisk initiatives and lead the discussions on NRC lead items, including the development of the Committee on the Safety of Nuclear Installations (CSNI) Activity Planning Sheet on the Nuclear Energy Agency's data project use. Nathan Siu will chair the WGRisk Bureau and Annual Meetings and ensure that CSNI direction is met. Gabriel Taylor will attend the WGRisk TG meeting on digital I&C failure mode taxonomy, and will visit Laurent Gay of EDF to discuss his current research related to electrical equipment failures under elevated thermal conditions.

6. OIP Communications

1. Memorandum to the Commission from Margaret M. Doane dated March 18, 2011 re Bimonthly List of Key International Meetings (ML110800275)
2. Letter to Richard Goorevich, DOE, from Margaret M. Doane dated March 24, 2011, re authorization for Westinghouse Electric Company to transfer technology associated with nuclear fuel fabrication equipment to China (ML110811229)

CONTACT: Janice Owens, 415-3684 regarding export/ import, IAEA, and NEA activities
Charlotte Abrams, 415-2933 regarding international cooperation activities
Steve Dembek, 415-2342 regarding other activities

From: [Sanfilippo, Nathan](#)
To: [Leeds, Eric](#); [Johnson, Michael](#); [Wiggins, Jim](#); [Moore, Scott](#); [Haney, Catherine](#); [Sheron, Brian](#); [Burns, Stephen](#); [Dean, Bill](#); [McCree, Victor](#); [Satorius, Mark](#); [Collins, Elmo](#); [Zimmerman, Roy](#)
Cc: [Grobe, Jack](#); [Holahan, Gary](#); [Miller, Charles](#); [Virgilio, Martin](#)
Subject: Monday's telecon to discuss the draft task force charter
Date: Friday, March 25, 2011 4:16:11 PM
Importance: High

All,

I just wanted to give you a little background for the scheduler you received for a Monday 4 PM teleconference.

The senior level agency task force to evaluate the need for agency actions following the events in Japan has been formed. It will be led by Charlie Miller, and includes Gary Holahan, Jack Grobe, and myself. The task force is writing its charter and will have a draft ready around lunchtime on Monday. We intend to send you that draft so it can be discussed at the 4 PM teleconference, at which time feedback is welcome. We realize this is a short turnaround, but we wanted to involve you as we finalize the charter, get it approved, and get to work – as the clock is ticking.

Thanks for your support on Monday – and feel free to have someone else sit in on the call if you are not available.

Thanks,
Nathan

Nathan Sanfilippo

Executive Technical Assistant
Office of the Executive Director for Operations
U.S. Nuclear Regulatory Commission
301.415.3951
nathan.sanfilippo@nrc.gov

CH/388

From: Sheron, Brian
To: Salley, MarkHenry; (b)(6)
Subject: RE: RES PLAN OF THE DAY: FRIDAY, MARCH 25, 2011
Date: Friday, March 25, 2011 4:35:00 PM

That figures. Nothing is ever easy. Kenny, thanks.

From: Salley, MarkHenry
Sent: Friday, March 25, 2011 4:03 PM
To: (b)(6); Sheron, Brian
Subject: Re: RES PLAN OF THE DAY: FRIDAY, MARCH 25, 2011

Thanx Z.

Brian. It looks like the first time its programmed it has to be done by the dealer. After that you can do it. Think of the first time like installing a piece of software.

Sent from an NRC Blackberry
Mark Henry Salley

(b)(6)

From: Ken Zwigart; (b)(6)
To: Salley, MarkHenry; Sheron, Brian
Sent: Fri Mar 25 14:15:45 2011
Subject: RE: RES PLAN OF THE DAY: FRIDAY, MARCH 25, 2011

Gordon said we got a fob for a pontiac and the dealer had to program it with a tech II scanner....

From: MarkHenry.Salley@nrc.gov
To: Brian.Sheron@nrc.gov; (b)(6)
Date: Thu, 24 Mar 2011 18:21:08 -0400
Subject: RE: RES PLAN OF THE DAY: FRIDAY, MARCH 25, 2011

Hmmmmmmmm. It says "Relearn Remote Key" I wonder if it needs some initial learning mode & that's what GM does?

Kenny Z may know:

Kenny, Brian bought a 2007 Tahoe. It only had one Key Fob, so he went to GM and bought another. Do you know how to program this first time, or is this something GM dealers must do? Can you please check with your GM parts supplier & email the response or instructions back to Brian.

Thanx

MHS

From: Sheron, Brian
Sent: Thursday, March 24, 2011 5:38 PM
To: Salley, MarkHenry
Subject: RE: RES PLAN OF THE DAY: FRIDAY, MARCH 25, 2011

Yuk, yuk, yuk.

CH/389

I'm perplexed. My service manual provides instructions on how to program a remote door lock opener. I also found the same instructions on several web sites.

I have a DIC set of switches on the right side of the dash. I'm to first push the DIC button that cycles through the odometer, trip odometer, fuel economy stuff, etc., until "Relearn Remote Key" pops up on the DIC. I then push on the DIC button that has a check mark on it, and a message "Remote Key Learning Active" pops up. You are then supposed to push down on both the lock and unlock buttons on the remote for about 15 seconds, until you hear a chime sound that says the transmitter is matched. Then you are supposed to cycle the key to "Lock" to get out of the programming mode.

I have gotten into the "Remote Key Learning Active" mode, and held the lock and unlock buttons down on the remote simultaneously for 15 seconds. However, there is no chime sound, and the remote doesn't control anything.

Last night I popped the back of the remote to see if maybe it didn't come with a battery, or if the battery was dead. It had a 3v battery in it, and when I checked it on my voltmeter, it read 3 volts, so the battery is good.

I can only surmise that either the programming instructions are in error, or somehow the remote that I bought is bad.

Any thoughts?

From: Salley, MarkHenry
Sent: Thursday, March 24, 2011 5:25 PM
To: Sheron, Brian
Cc: Uhle, Jennifer
Subject: FW: RES PLAN OF THE DAY: FRIDAY, MARCH 25, 2011

I like that joke in the Plan of the Day.....

Q: *Where does bad light end up?*
A: *In a prism.*

Funny, but that's the same place bad Fire Tests end up!

From: Flory, Shirley
Sent: Thursday, March 24, 2011 4:40 PM
To: RES Distribution; Cruz, Holly; Cullison, David; Frampton, Julie; Hudson, Nathanael; Peters, Sean; Richards, Stuart; Rini, Brett; Santiago, Patricia
Subject: RES PLAN OF THE DAY: FRIDAY, MARCH 25, 2011

From: Sheron, Brian
To: HOO Hoc
Cc: Weber, Michael; Virgilio, Martin
Subject: FW: Reactor Safety Team Assessment 2000 EDT 3-24-2011
Date: Friday, March 25, 2011 4:41:00 PM

Please pass this on to ET and RST. According to DOE, they are pumping fresh water into unit 1.

From: Kelly, John E (NE) [mailto:JohnE.Kelly@Nuclear.Energy.Gov]
Sent: Friday, March 25, 2011 4:20 PM
To: Sheron, Brian
Subject: RE: Reactor Safety Team Assessment 2000 EDT 3-24-2011

there was an aqueduct from a dam (reservoir) some distance away that they tapped into. They're storing fresh water in condensate cooling pool and then pumping in. Also heard US Navy had sent barges with fresh water and that JP Navy would refill using desalination equipment.

From: Sheron, Brian
Sent: Friday, March 25, 2011 2:55 PM
To: Kelly, John E (NE)
Subject: RE: Reactor Safety Team Assessment 2000 EDT 3-24-2011

John, the report says for unit one, under core cooling, that they have freshwater injection through the feedwater system. True? Where did they get freshwater from?

From: Kelly, John E (NE) [mailto:JohnE.Kelly@Nuclear.Energy.Gov]
Sent: Friday, March 25, 2011 1:50 PM
To: DL-NITSolutions
Subject: FW: Reactor Safety Team Assessment 2000 EDT 3-24-2011

Integrated DOE-NRC-INPO report to Japan

From: Versluis, Rob
Sent: Thursday, March 24, 2011 10:28 PM
To: DL-NERT-All
Subject: Fw: Reactor Safety Team Assessment 2000 EDT 3-24-2011

Fyi
Rob Versluis +1-301-903-1890(o) (b)(6) (m)

From: RST01 Hoc <RST01.Hoc@nrc.gov>
To: RST01 Hoc <RST01.Hoc@nrc.gov>; RST02 Hoc <RST02.Hoc@nrc.gov>; mossdj@inpo.org <mossdj@inpo.org>; Casto, Chuck <Chuck.Casto@nrc.gov>; Nakanishi, Tony <Tony.Nakanishi@nrc.gov>; Monninger, John <John.Monninger@nrc.gov>; Devercelly, Richard <Richard.Devercelly@nrc.gov>; Foster, Jack <Jack.Foster@nrc.gov>; Trapp, James <James.Trapp@nrc.gov>
Cc: RST03 Hoc <RST03.Hoc@nrc.gov>; INPOERCAssistance <INPOERCAssistance@inpo.org>; Ruland, William <William.Ruland@nrc.gov>; Versluis, Rob
Sent: Thu Mar 24 22:25:22 2011
Subject: Reactor Safety Team Assessment 2000 EDT 3-24-2011

All,

CH/390

The reactor safety team has compiled its assessment report of conditions and recommendations at the damaged Fukushima Daiichi reactor plants.

Shortly after our completion of the attached report, the RST received a new update from JAIF with a time-date stamp of 2200 JDT 3/24/2011 (0900 EDT 3/24/2011), that indicates changes in their view of containment integrity in units One and Three, indicating the containment vessel integrity status as "Not Damaged". This information has not been factored into the assessment report, and the RST will be moving forward to review and evaluate this latest status report.

We request that our INPO addressee please forward this assessment to the EPRI staff who are involved in this event response activity.

If you have any comments or questions on this report, please contact the Reactor Safety Team at RST01.Hoc@nrc.gov.

John Thorp
RST Chronologist Evening Shift, 3/24/2011

From: [Sheron, Brian](#)
To: [ET05 Hoc](#)
Subject: RE: Priority for Fukushima-Daiichi Units
Date: Friday, March 25, 2011 4:42:00 PM

Great, thanks.

From: ET05 Hoc
Sent: Friday, March 25, 2011 4:23 PM
To: Sheron, Brian
Subject: FW: Priority for Fukushima-Daiichi Units

Good afternoon,

In answer to your question about the change in priorities, I'm attaching information from our Reactor Safety Team. This information will be added to the SITRep. Please let me know if there's anything else I can help you with. There is a task entered into the tracker for response to all of the congressional questions that you passed along through the HOOs.

Regards,
Melissa Ralph
Melissa.Ralph@nrc.gov
ET Actions Officer (et05.hoc@nrc.gov)
NRC Headquarters Operation Center

From: RST01 Hoc
Sent: Friday, March 25, 2011 4:19 PM
To: ET05 Hoc
Subject: Priority for Fukushima-Daiichi Units

Per Joe Giiter's request:

Per John Thorp, RST Communicator, at 2319 on 3/24/11:

Updated the Fukushima Daiichi Status Summary, based on the RST Assessment Report identified in the prior entry. The main source of information for the table has not been updated, but the Assessment report and the analysis by the RST during its development led to a decision to assign a revised priority to Units 1 through 4. Unit 1 is priority 1 based on the fact that primary containment integrity can still be preserved, if the responders take the correct actions to inject to the RPV and Primary containment. Unit 2 is priority 2 because of the apparent damage to primary containment and the other barriers to release, requiring continued attention to cool the core and provide water to the primary containment to minimize potential for release. Unit 3 is priority 3, because primary containment may be OK but continued attention is required to pursue core cooling and injection. Unit 4 is priority 4 because of progress in addressing the spent fuel pool heat

CH/391

removal requirements, and indicated SFP area temperatures of less than 100degrees C.

Brett Rini
RST Coordinator

From: [Sheron, Brian](#)
To: [Riley \(OCA\), Timothy](#)
Subject: FW: Priority for Fukushima-Daiichi Units
Date: Friday, March 25, 2011 4:43:00 PM

Tim, below is the response to the question about why our priorities changed. Please pass this on to the appropriate staffer who asked the question. Thanks.

From: ET05 Hoc
Sent: Friday, March 25, 2011 4:23 PM
To: Sheron, Brian
Subject: FW: Priority for Fukushima-Daiichi Units

Good afternoon,

In answer to your question about the change in priorities, I'm attaching information from our Reactor Safety Team. This information will be added to the SITRep. Please let me know if there's anything else I can help you with. There is a task entered into the tracker for response to all of the congressional questions that you passed along through the HOOs.

Regards,
Melissa Ralph
Melissa.Ralph@nrc.gov
ET Actions Officer (et05.hoc@nrc.gov)
NRC Headquarters Operation Center

From: RST01 Hoc
Sent: Friday, March 25, 2011 4:19 PM
To: ET05 Hoc
Subject: Priority for Fukushima-Daiichi Units

Per Joe Giiter's request:

Per John Thorp, RST Communicator, at 2319 on 3/24/11:

Updated the Fukushima Daiichi Status Summary, based on the RST Assessment Report identified in the prior entry. The main source of information for the table has not been updated, but the Assessment report and the analysis by the RST during its development led to a decision to assign a revised priority to Units 1 through 4. Unit 1 is priority 1 based on the fact that primary containment integrity can still be preserved, if the responders take the correct actions to inject to the RPV and Primary containment. Unit 2 is priority 2 because of the apparent damage to primary containment and the other barriers to release, requiring continued attention to cool the core and provide water to the primary containment to minimize potential for release. Unit 3 is priority 3, because primary containment may be OK but continued attention is required to pursue core cooling and

CH/392

injection. Unit 4 is priority 4 because of progress in addressing the spent fuel pool heat removal requirements, and indicated SFP area temperatures of less than 100degrees C.

Brett Rini
RST Coordinator

From: [Riley \(OCA\), Timothy](#)
To: [Sheron, Brian](#)
Subject: RE: Priority for Fukushima-Daiichi Units
Date: Friday, March 25, 2011 4:44:06 PM

Doing so now. Thanks again.

From: Sheron, Brian
Sent: Friday, March 25, 2011 4:44 PM
To: Riley (OCA), Timothy
Subject: FW: Priority for Fukushima-Daiichi Units

Tim, below is the response to the question about why our priorities changed. Please pass this on to the appropriate staffer who asked the question. Thanks.

From: ET05 Hoc
Sent: Friday, March 25, 2011 4:23 PM
To: Sheron, Brian
Subject: FW: Priority for Fukushima-Daiichi Units

Good afternoon,

In answer to your question about the change in priorities, I'm attaching information from our Reactor Safety Team. This information will be added to the SITRep. Please let me know if there's anything else I can help you with. There is a task entered into the tracker for response to all of the congressional questions that you passed along through the HOOs.

Regards,
Melissa Ralph
Melissa.Ralph@nrc.gov
ET Actions Officer (et05.hoc@nrc.gov)
NRC Headquarters Operation Center

From: RST01 Hoc
Sent: Friday, March 25, 2011 4:19 PM
To: ET05 Hoc
Subject: Priority for Fukushima-Daiichi Units

Per Joe Giiter's request:

Per John Thorp, RST Communicator, at 2319 on 3/24/11:

Updated the Fukushima Daiichi Status Summary, based on the RST Assessment Report identified in the prior entry. The main source of information for the table has not been updated, but the Assessment report and the analysis by the RST during its development led to a decision to assign a revised priority to Units 1 through 4. Unit 1 is priority 1 based on the fact that primary containment integrity can still be preserved, if the responders take

CH/393

the correct actions to inject to the RPV and Primary containment. Unit 2 is priority 2 because of the apparent damage to primary containment and the other barriers to release, requiring continued attention to cool the core and provide water to the primary containment to minimize potential for release. Unit 3 is priority 3, because primary containment may be OK but continued attention is required to pursue core cooling and injection. Unit 4 is priority 4 because of progress in addressing the spent fuel pool heat removal requirements, and indicated SFP area temperatures of less than 100degrees C.

Brett Rini
RST Coordinator

From: [Dehn, Jeff](#)
To: [Sheron, Brian](#)
Cc: [Uhle, Jennifer](#); [Gibson, Kathy](#); [Scott, Michael](#); [Rubin, Stuart](#); [Sangimino, Donna-Marie](#); [Basu, Sudhamay](#); [Zaki, Tarek](#)
Subject: China HTGR Alignment
Date: Friday, March 25, 2011 4:46:58 PM
Attachments: [Re China activities and HTGR agreement.msg](#)
[NNSA-NRC htgr_fyd0415.doc](#)
[NNSA-NRC htgr_agreement-DRAFT_March2010-clean-v9.doc](#)

Brian, All,

Some background concerning the proposed HTGR agreement with China. Attached is another background email, and two versions of an agreement: 1st – China's proposal; 2nd – RES/NRO's possible counterproposal.

Situation:

(b)(5)

(b)(5)

CH/394

(b)(5)

Thank you,
Jeff

Jeff Dehn

International Relations Specialist
Office of Nuclear Regulatory Research (RES)
US Nuclear Regulatory Commission
jeff.dehn@nrc.gov
301-251-7672
C-6D22

Attachment Re China activities and HTGR agreement.msg (2560 Bytes) cannot be converted to PDF format.

(b)(5)

(b)(5)

(b)(5)

(b)(5)

(b)(5)

(b)(5)

(b)(5)

(b)(5)

(b)(5)

(b)(5)

(b)(5)

(b)(5)

(b)(5)

(b)(5)

(b)(5)

(b)(5)

(b)(5)

(b)(5)

(b)(5)

(b)(5)

(b)(5)

(b)(5)

(b)(5)

(b)(5)

(b)(5)

(b)(5)

(b)(5)

(b)(5)

(b)(5)

(b)(5)

(b)(5)

(b)(5)

From: [Sheron, Brian](#)
To: [Gibson, Kathy](#); [Schaperow, Jason](#)
Subject: FW: House E&C request
Date: Friday, March 25, 2011 4:50:00 PM

Jason, see below. Can you respond to Gene with the link?

From: Dacus, Eugene
Sent: Friday, March 25, 2011 4:27 PM
To: Sheron, Brian
Subject: FW: House E&C request

Brian,

Can you direct me to the link Jeff is requesting?

From: Baran, Jeff [<mailto:Jeff.Baran@mail.house.gov>]
Sent: Friday, March 25, 2011 3:03 PM
To: Dacus, Eugene
Cc: Cassidy, Alison
Subject: RE: House E&C request

Thanks again for setting up the call. If you can send us a link to the SOARCA slides, that'd be much appreciated.

Jeff

From: Dacus, Eugene [<mailto:Eugene.Dacus@nrc.gov>]
Sent: Thursday, March 24, 2011 5:39 PM
To: Baran, Jeff
Subject: RE: House E&C request

Great...we'll call you. Your office right?

From: Baran, Jeff [<mailto:Jeff.Baran@mail.house.gov>]
Sent: Thursday, March 24, 2011 5:37 PM
To: Dacus, Eugene
Subject: Re: House E&C request

2pm would be fine.

Jeff

From: Dacus, Eugene [<mailto:Eugene.Dacus@nrc.gov>]
Sent: Thursday, March 24, 2011 05:32 PM
To: Baran, Jeff
Subject: RE: House E&C request

Jeff,

Does 2:00 pm work for you?

CH/395

From: Baran, Jeff [mailto:Jeff.Baran@mail.house.gov]
Sent: Thursday, March 24, 2011 4:05 PM
To: Dacus, Eugene
Subject: Re: House E&C request

Thanks, Gene. I think a brief call with Brian about SOARCA would be helpful. It would be good to get a sense of whether this is something we'd want to get a detailed briefing on down the road. Right now, I'm available anytime tomorrow if that would work for Brian.

Jeff

From: Dacus, Eugene [mailto:Eugene.Dacus@nrc.gov]
Sent: Thursday, March 24, 2011 02:50 PM
To: Baran, Jeff; Dotson, Greg; Cassady, Alison
Cc: Powell, Amy <Amy.Powell@nrc.gov>
Subject: FW: House E&C request

Jeff,

I thought I would be able to get you the document (SOARCA) that Brian referred to in his briefing, but unfortunately, the SOARCA is still in very rough draft and the staff feels that releasing it in its current form would be too problematic. Currently, the staff doesn't have an estimate of when the SOARCA analysis will be released. Background the SOARCA process and the three plant studied is located in NUREG 1925, Rev 1, Chapter 3: Severe Accident Research and Consequence Analysis. If you have specific questions about the SOARCA and you think a call from Brian would help, let me know and I'll set it up.

http://www.internal.nrc.gov/RES/RES%20NUREG-1925_Rev_1.pdf

Gene

From: Dacus, Eugene
Sent: Tuesday, March 22, 2011 3:33 PM
To: Baran, Jeff; Powell, Amy
Cc: Dotson, Greg; Cassady, Alison
Subject: RE: House E&C request

Jeff

I checked with Brian....answer below

During the briefing I gave to House staffers last week, I referred to the SOARCA analysis of Peach Bottom. I did not mention relicensing or license renewal.

The SOARCA results are not yet publicly available, but I'll get you copies.

Gene

From: Baran, Jeff [mailto:Jeff.Baran@mail.house.gov]
Sent: Tuesday, March 22, 2011 9:35 AM
To: Dacus, Eugene; Powell, Amy
Cc: Dotson, Greg; Cassidy, Alison
Subject: Re: House E&C request

Thanks, Gene. We'll take a look at this. When Brian is available, please check with him to confirm this is what he was referring to.

Jeff

From: Dacus, Eugene <Eugene.Dacus@nrc.gov>
To: Powell, Amy <Amy.Powell@nrc.gov>; Baran, Jeff
Cc: Dotson, Greg; Cassidy, Alison
Sent: Mon Mar 21 16:59:52 2011
Subject: RE: House E&C request

Jeff,

Brian Sheron is one of the Ops Center shift directors and is off duty at present. However, I've spoken with the staff and it's believed that Brian was referring to the SAMA (Severe Accident Mitigation Alternatives) analysis in the plant-specific supplement to the Environmental Impact Statement that was issued as part of the license renewal process. It is publicly available, and contained in Section 5 of the following link on our web page to the Supplemental EIS:

<http://www.nrc.gov/reading-rm/doc-collections/nuregs/staff/sr1437/supplement10/>

If, we missed the mark, I will get with Brian when he comes in for his next shift.

Regards

Gene

From: Powell, Amy
Sent: Friday, March 18, 2011 8:14 PM
To: Baran, Jeff
Cc: Dotson, Greg; Cassidy, Alison; Dacus, Eugene
Subject: House E&C request

Hi Jeff –

I will be on travel until Thursday of next week. I have cc'ed Gene Dacus in our office; he will follow up on your request. I am glad that today's briefing was informative for you all.

Thanks,
Amy

Amy Powell
Associate Director
U. S. Nuclear Regulatory Commission

Office of Congressional Affairs
Phone: 301-415-1673

From: Baran, Jeff [mailto:Jeff.Baran@mail.house.gov]
Sent: Friday, March 18, 2011 4:56 PM
To: Powell, Amy
Cc: Dotson, Greg; Cassady, Alison
Subject: Follow-up

Hi Amy,

We had a very informative discussion with Brian Sheron earlier. Thanks for helping to set that up. He mentioned that, for the Peach Bottom license renewals, NRC ran several scenarios as part of a risk assessment to calculate the consequences of certain severe events. We're interested in reviewing the documentation regarding these scenarios. If the document(s) is/are on ADAMS and you can point me in the right direction, that'd be great. If it's not publicly available, we'd still be very interested in getting copies of the documents next week.

Feel free to call if you have any questions.

Thanks,

Jeff

From: [Sheron, Brian](#)
To: [Evans, Michele](#)
Subject: RE: Updated ET Directors schedule
Date: Friday, March 25, 2011 4:52:00 PM

I can do the 4/10 3pm-11pm shift.

From: Evans, Michele
Sent: Friday, March 25, 2011 4:33 PM
To: Boger, Bruce; Sheron, Brian; Zimmerman, Roy; Johnson, Michael; Uhle, Jennifer; Dyer, Jim; Carpenter, Cynthia
Cc: Wiggins, Jim; Weber, Michael; Taylor, Renee; Salus, Amy; Schwarz, Sherry; Flory, Shirley; Sprogeris, Patricia; Virgilio, Martin
Subject: Updated ET Directors schedule

Again, thank you for everyone's input to the schedule.

All shifts are taken through Tuesday March 29. However, we need dayshift for March 30 and 31 as well as a few other shifts beyond that date.

Please reply to me via email if you can take any of the remaining shifts.

Have a nice weekend.

Michele

CH/396

From: Sheron, Brian
To: Kelly, John E (NE)
Subject: RE: Reactor Safety Team Assessment 2000 EDT 3-24-2011
Date: Friday, March 25, 2011 4:53:00 PM

Thanks.

From: Kelly, John E (NE) [mailto:JohnE.Kelly@Nuclear.Energy.Gov]
Sent: Friday, March 25, 2011 4:52 PM
To: Sheron, Brian
Subject: RE: Reactor Safety Team Assessment 2000 EDT 3-24-2011

as best we can tell the salt stays in the vessel mostly. There is a thought that recirc pumps are leaking so that is a pathway. Otherwise only steam goes from RPV to containment

From: Sheron, Brian
Sent: Friday, March 25, 2011 4:39 PM
To: Kelly, John E (NE)
Subject: RE: Reactor Safety Team Assessment 2000 EDT 3-24-2011

Are flushing salt out, and if so, do we know where it is going?

From: Kelly, John E (NE) [mailto:JohnE.Kelly@Nuclear.Energy.Gov]
Sent: Friday, March 25, 2011 4:20 PM
To: Sheron, Brian
Subject: RE: Reactor Safety Team Assessment 2000 EDT 3-24-2011

there was an aqueduct from a dam (reservoir) some distance away that they tapped into. They're storing fresh water in condensate coiling pool and then pumping in. Also heard US Navy had sent barges with fresh water and that JP Navy would refill using desalination equipment.

From: Sheron, Brian
Sent: Friday, March 25, 2011 2:55 PM
To: Kelly, John E (NE)
Subject: RE: Reactor Safety Team Assessment 2000 EDT 3-24-2011

John, the report says for unit one, under core cooling, that they have freshwater injection through the feedwater system. True? Where did they get freshwater from?

From: Kelly, John E (NE) [mailto:JohnE.Kelly@Nuclear.Energy.Gov]
Sent: Friday, March 25, 2011 1:50 PM
To: DL-NITSolutions
Subject: FW: Reactor Safety Team Assessment 2000 EDT 3-24-2011

Integrated DOE-NRC-INPO report to Japan

From: Versluis, Rob
Sent: Thursday, March 24, 2011 10:28 PM
To: DL-NERT-All
Subject: Fw: Reactor Safety Team Assessment 2000 EDT 3-24-2011

Fyi
Rob Versluis +1-301-903-1890(o) (b)(6) (m)

CH/397

From: RST01 Hoc <RST01.Hoc@nrc.gov>
To: RST01 Hoc <RST01.Hoc@nrc.gov>; RST02 Hoc <RST02.Hoc@nrc.gov>; mossdj@inpo.org <mossdj@inpo.org>; Casto, Chuck <Chuck.Casto@nrc.gov>; Nakanishi, Tony <Tony.Nakanishi@nrc.gov>; Monninger, John <John.Monninger@nrc.gov>; Devercelly, Richard <Richard.Devercelly@nrc.gov>; Foster, Jack <Jack.Foster@nrc.gov>; Trapp, James <James.Trapp@nrc.gov>
Cc: RST03 Hoc <RST03.Hoc@nrc.gov>; INPOERCAssistance <INPOERCAssistance@inpo.org>; Ruland, William <William.Ruland@nrc.gov>; Versluis, Rob
Sent: Thu Mar 24 22:25:22 2011
Subject: Reactor Safety Team Assessment 2000 EDT 3-24-2011

All,

The reactor safety team has compiled its assessment report of conditions and recommendations at the damaged Fukushima Daiichi reactor plants.

Shortly after our completion of the attached report, the RST received a new update from JAIF with a time-date stamp of 2200 JDT 3/24/2011 (0900 EDT 3/24/2011), that indicates changes in their view of containment integrity in units One and Three, indicating the containment vessel integrity status as "Not Damaged". This information has not been factored into the assessment report, and the RST will be moving forward to review and evaluate this latest status report.

We request that our INPO addressee please forward this assessment to the EPRI staff who are involved in this event response activity.

If you have any comments or questions on this report, please contact the Reactor Safety Team at RST01.Hoc@nrc.gov.

John Thorp
RST Chronologist Evening Shift, 3/24/2011

From: Coe, Doug
To: Bowman, Gregory; Hudson, Daniel; Gibson, Kathy; Elkins, Scott
Cc: Coyne, Kevin; Correia, Richard; Uhle, Jennifer; Sheron, Brian
Subject: Re: RESPONSE: Draft Level 3 PRA Commission Meeting Scheduling Note
Date: Friday, March 25, 2011 4:53:46 PM

Kathy
Scott
See the severe accident discussion below
It is taking on more importance than we initially thought
We will coordinate with you next week
Doug

Sent from an NRC BlackBerry
Doug Coe

(b)(6)

From: Bowman, Gregory
To: Hudson, Daniel
Cc: Coyne, Kevin; Coe, Doug; Correia, Richard
Sent: Fri Mar 25 16:24:08 2011
Subject: RE: RESPONSE: Draft Level 3 PRA Commission Meeting Scheduling Note

This looks good.

(b)(5)

Mike said he was going to give Brian a call to go over all this with him, too.

Thanks again for the help in getting this turned around quickly. I appreciate it.

Greg

From: Hudson, Daniel
Sent: Friday, March 25, 2011 3:39 PM
To: Bowman, Gregory
Cc: Coyne, Kevin; Coe, Doug; Correia, Richard; Gibson, Kathy; Uhle, Jennifer; Sheron, Brian
Subject: RESPONSE: Draft Level 3 PRA Commission Meeting Scheduling Note

Greg,

CH/398

As requested, we have revised the draft Level 3 PRA Commission Meeting scheduling note to address the Chairman's feedback regarding the removal of SOARCA and the addition of an external panel and a severe accidents topic. The revised draft is attached for your review.

Please note that NEI has not yet identified a specific individual that SECY could invite to participate in the external panel, should the Commission determine that NEI will be invited to participate. I will provide you with an update as more information becomes available.

Please let me know if you have any questions, comments, or concerns.

Best regards,
Dan

Daniel W. Hudson
Technical Assistant
U.S. Nuclear Regulatory Commission
Office of Nuclear Regulatory Research
Division of Risk Analysis
Daniel.Hudson@nrc.gov
301-251-7919

From: Binkley, Steve
To: "david.hobbs@srnl.doe.gov"; Adams, Ian; Aoki, Steven; Binkley, Steve; Bob Budnitz; Sheron, Brian; Brinkman, Bill; D'Agostino, Thomas; Dick Garwin; Dick Garwin; Harold Denton; Harold McFarlane; Hurlbut, Brandon; John Grossenbacher; John Holdren; Kelly, John E (NE); Koonin, Steven; Lyons, Peter; Owens, Missy; Per Peterson; Phil Finck; Poneman, Daniel; Lee, Richard; Rolando Szilard; SCHU; Steve Fetter
Subject: FW: Science council presentation, 3/25
Date: Friday, March 25, 2011 4:54:47 PM
Attachments: 0325 Sec Briefing1-1.pptx

From: Kelly, John E (NE)
Sent: Friday, March 25, 2011 4:51 PM
To: Binkley, Steve
Subject: FW: Science council

From: Kelly, John E (NE)
Sent: Friday, March 25, 2011 4:42 PM
To: NITSolutions
Subject: Science council

slides for today

Dr. John E. Kelly
Deputy Assistant Secretary for Nuclear Reactor Technologies
NE-7
U.S. Department of Energy
1000 Independence Ave. SW
Washington, DC 20585
phone: 202-586-5458
fax: 202-586-0541
mobile: (b)(6)

CH/399



U.S. DEPARTMENT OF

ENERGY

Nuclear Energy

**Science Council
Briefing on Fukushima Nuclear
Plant Response**

*John E. Kelly
Steve Binkley
Steve Aoki*

March 25, 2011



U.S. DEPARTMENT OF
ENERGY

TOC

Nuclear Energy

- 1. Sensors**
- 2. Corrosion mitigation**
- 3. Hydrogen control in containment**
- 4. Reactor diagrams, including vent**



U.S. DEPARTMENT OF
ENERGY

Nuclear Energy

2 – Corrosion Mitigation



U.S. DEPARTMENT OF
ENERGY

Nuclear Energy

Near-term corrosion of key structural components is occurring

- Fukushima reactor corrosion
 - Pitting and/or SCC of stainless steel internals
 - General corrosion of the RPV
 - Potential corrosive attack on concrete
- Accelerated in salt (and/or borated) solutions
- Corrosion process must be considered for the long-term



U.S. DEPARTMENT OF
ENERGY

Long-Term Containment

Nuclear Energy

- The reactor pressure vessel will be the key barrier
- The stainless steel core internals do not serve as a functional barrier from the RPV steel



U.S. DEPARTMENT OF
ENERGY

Nuclear Energy

Incident at Davis Besse gives some insight into potential corrosion rates

- Corrosion of the RPV head at Davis Besse (due to boric acid corrosion on the top of the vessel)
- Tests were performed in a prototypic environment to estimate corrosion rate.
 - Using concentrated boric acid, corrosion rate was on the order of 2-2.5 inches/year.
 - Similar steels and temperatures for Fukushima
- Corrosion rates could be higher in the Fukushima reactors in the current conditions given higher temperatures and *potential* for concentrated saline or boric acid.
- *Even at higher rates than Davis-Besse, vessel may last for a year or longer.*



- Flush with fresh water.
 - Reduce salt concentrations
 - Dilution may take a long time due to concentrations that might exist
 - Possibility of local salt pockets
- Keep the reactor vessel cool.
 - Corrosion is a strong function of temperature.
- When possible, keep the outside of vessel dry and away from moisture
 - Desiccants
 - Runs contrary to thermal management



U.S. DEPARTMENT OF
ENERGY

Long-term Mitigation Concepts

Nuclear Energy

- Use of sacrificial electrodes
 - Cable-connections to reactive metals like Mg can reduce corrosion rates.
- Use same electrode concept to "plate" protective layer on inside of RPV.
- Convert the halide complex salt to a different anion that is less aggressive.
- Use NaOH as pH control to neutralize acidic, sea water environment.
- Saturate inside of reactor with Fe (such as FeCl) to reduce potential towards reactor vessel.



U.S. DEPARTMENT OF
ENERGY

Long-Term Mitigation Concepts

Nuclear Energy

- Flood the system with an inhibitor.
 - Chromate
 - Vanadates, molybdates, proprietary commercial concoctions
 - A company called Dinalyne makes salt solutions with corrosion inhibitors. Could ask for those inhibitors.
- Add sulfates (or borates) or some other anion to get cations to precipitate



U.S. DEPARTMENT OF

ENERGY

3 – Hydrogen Control in Containment

Nuclear Energy

- Issue with hydrogen control is oxygen concentration
- Japanese are contemplating containment sprays, which would deinert (steam condenses)
- Need to know how much oxygen is in containment (pO_2)



U.S. DEPARTMENT OF
ENERGY

Nuclear Energy

Potential O₂ Ingress into Containment from Seawater

- Solubility of dissolved O₂ in seawater decreases by ~ 2.6 mg/kg upon heating inside containment.
- For Unit 1, based on estimated seawater injection 7950 MT, O₂ brought into system by solubility reduction is ~ 14.3 kg (445 moles)
 - Remaining free volume in Unit 1 estimated as 3500 - 5000 m³.
 - Corresponding partial pressure of O₂ in gas space is thus 2 to 3 mBar.
 - Vacuum breakers on Torus; not clear if additional oxygen from air brought in through the breakers or other leaks.
- For Unit 3, based on estimated seawater injection 10,559 MT, O₂ brought into system by solubility reduction is ~ 18.6 kg (580 moles)
 - Remaining free volume in Unit 3 estimated as 1300 - 4300 m³.
 - Corresponding partial pressure of O₂ in gas space is thus 3 to 10 mBar.
- These concentrations would not be flammable



U.S. DEPARTMENT OF

ENERGY

4 – Reactor Diagrams

Nuclear Energy

- Numerous drawings are available and will be sent if desired
- Includes reactor, vent, RHR system, etc.
- Working to obtain a cutaway that shows reactor penetrations
- Representative drawings are included in backup section



U.S. DEPARTMENT OF
ENERGY

Hardened Vent re: Pilgrim

Nuclear Energy

- **Response to NRC Generic Letter 89-16 to reduce vulnerability to severe accident challenges to Mark I containments**
- **Direct vent path from torus to plant stack**
- **20" pipe replaced 20" duct with 8" bypass line around standby gas treatment system**
- **Goal: Reduce energy release from a Hydrogen/Oxygen reaction from a degraded core**
- **Improved containment venting capability for decay heat removal**
 - Reduces potential onsite and offsite impacts



U.S. DEPARTMENT OF
ENERGY

Nuclear Energy

Direct Torus Vent System (Pilgrim)

DIRECT TORUS VENT SYSTEM

FIGURE 3.2-1

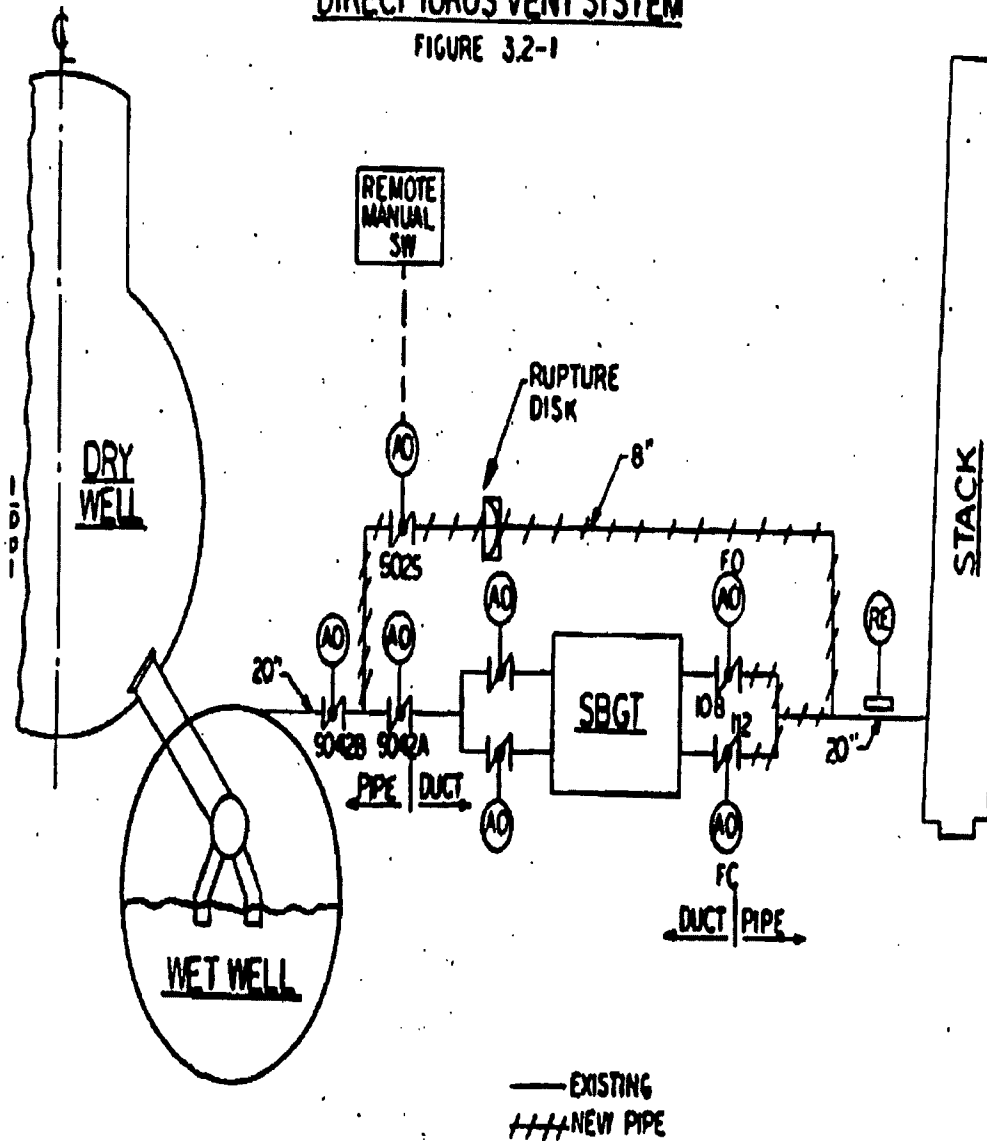



U.S. DEPARTMENT OF
ENERGY

Nuclear Energy

Reactor Vessel Injection System Options

Table 3.1 Reactor vessel injection system capacities
at the Browns Ferry Nuclear Plant

System	Total capacity (gal/min)	Power requirement	Number of pumps	Vessel depressurization required?
Residual heat removal (RHR)	40,000	ac	4	Yes
Core spray	12,500	ac	4	Yes
Control rod drive hydraulic system ^a	120-518	ac	2	No
Standby liquid control system (SLCS) ^b	56	ac	1	No
High-pressure coolant injection (HPCI)	5,000	Steam turbine, dc	1	No
Reactor core isolation cooling (RCIC)	600	Steam turbine, dc	1	No

^a The injection rate is determined by operator actions taken to enhance the flow (see Table 3.1 of Ref. 12).

^b Two SLCS pumps are installed, but system interlocks permit only one to be operated at a time.

BACKUP SLIDES



U.S. DEPARTMENT OF
ENERGY

Nuclear Energy

Quick Comparison of Mark I, II, III Designs

- Mark I suppression pool is located in the steel torus shaped ring below the reactor vessel (refer to drawing A)
- Mark II suppression pool is located in steel lined concrete structures also below the reactor vessel (refer to drawing B)
- Mark III suppression pool is located in a free standing steel containment surrounding the reactor vessel (refer to drawing C).
- The function of the suppression pools in all three designs is to condense the steam from the reactor vessel for pressure suppression during emergency conditions
- All three pressure suppression pools are surrounded by concrete secondary containment buildings
- The containment design changes were part of product evolution.



U.S. DEPARTMENT OF
ENERGY

Nuclear Energy

Containment Type – Mark I

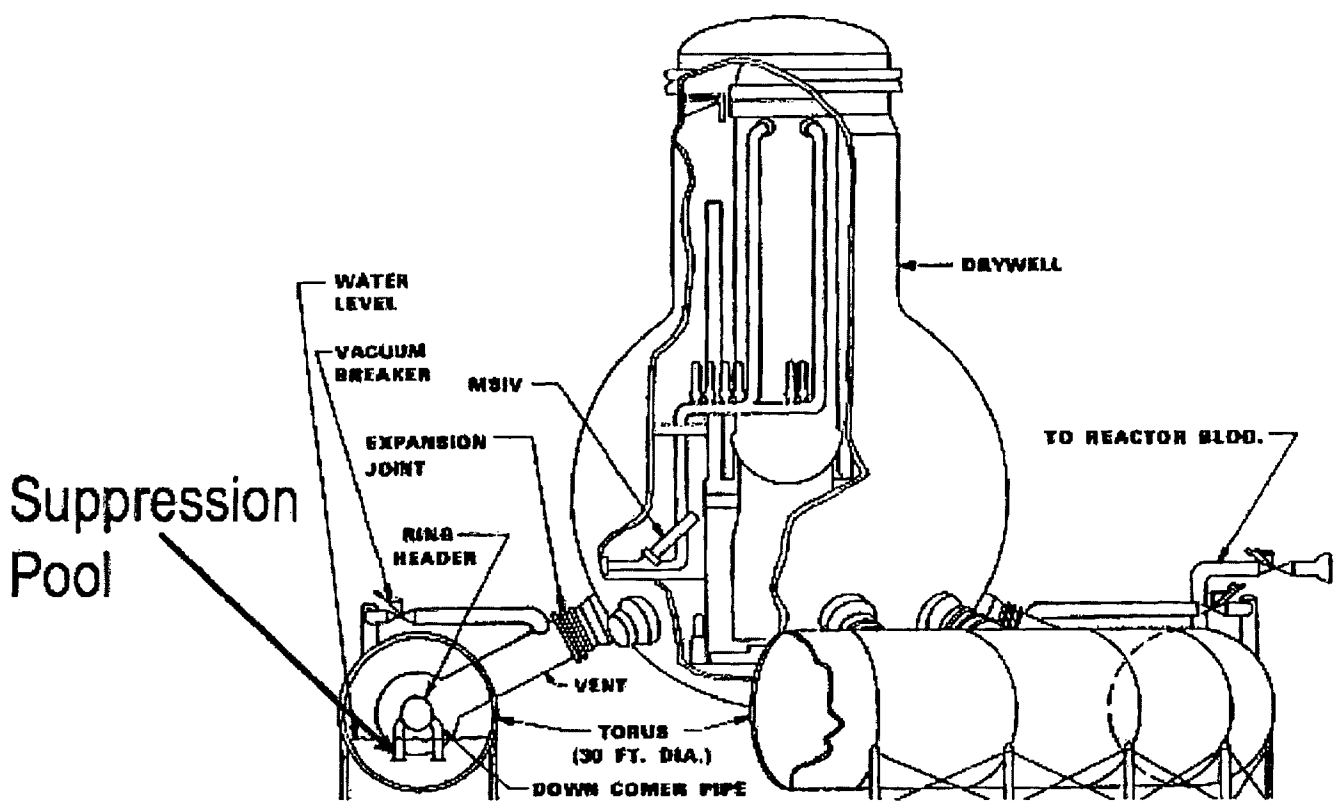



U.S. DEPARTMENT OF
ENERGY

Containment Type - Mark 1

Nuclear Energy

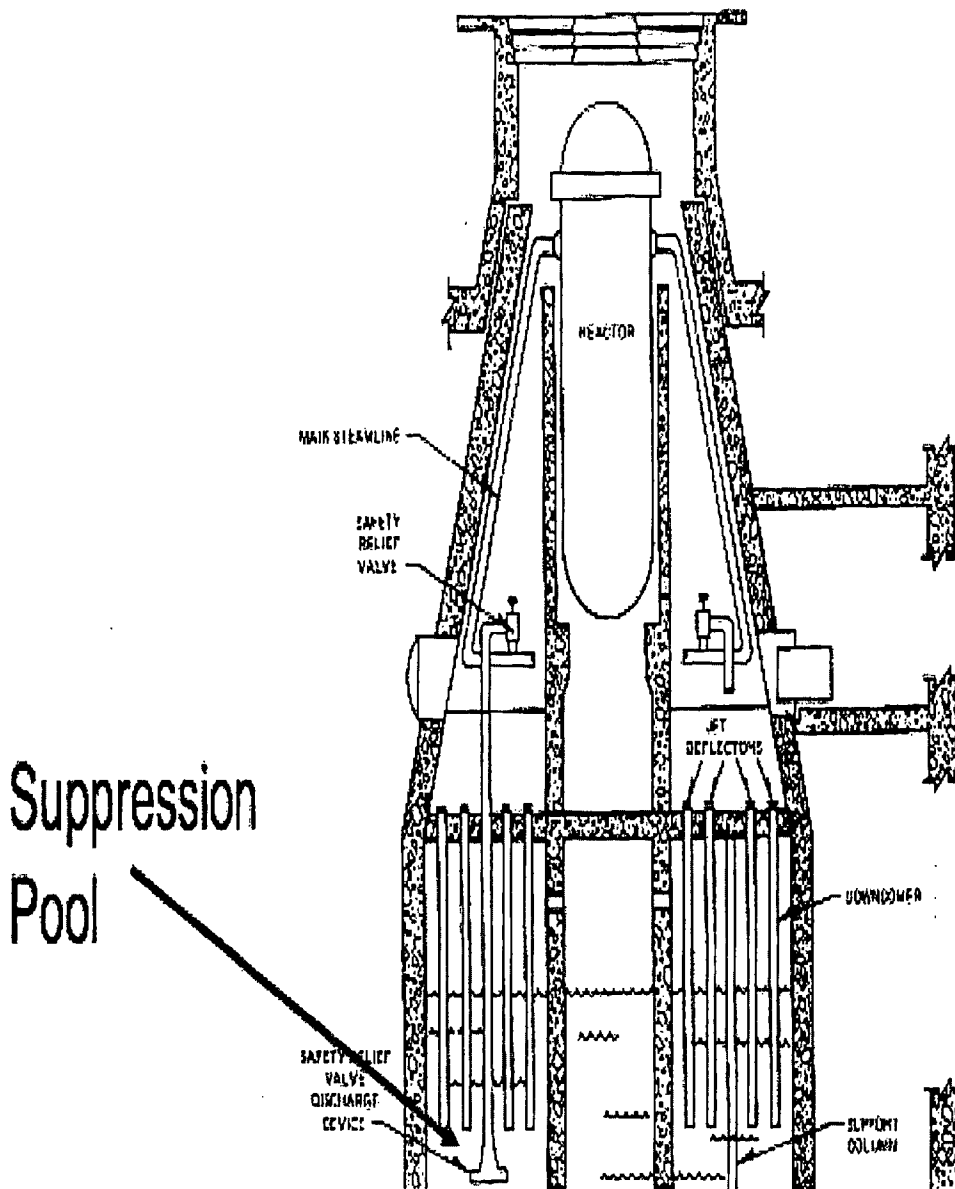



U.S. DEPARTMENT OF
ENERGY

Containment Type - Mark III

Nuclear Energy

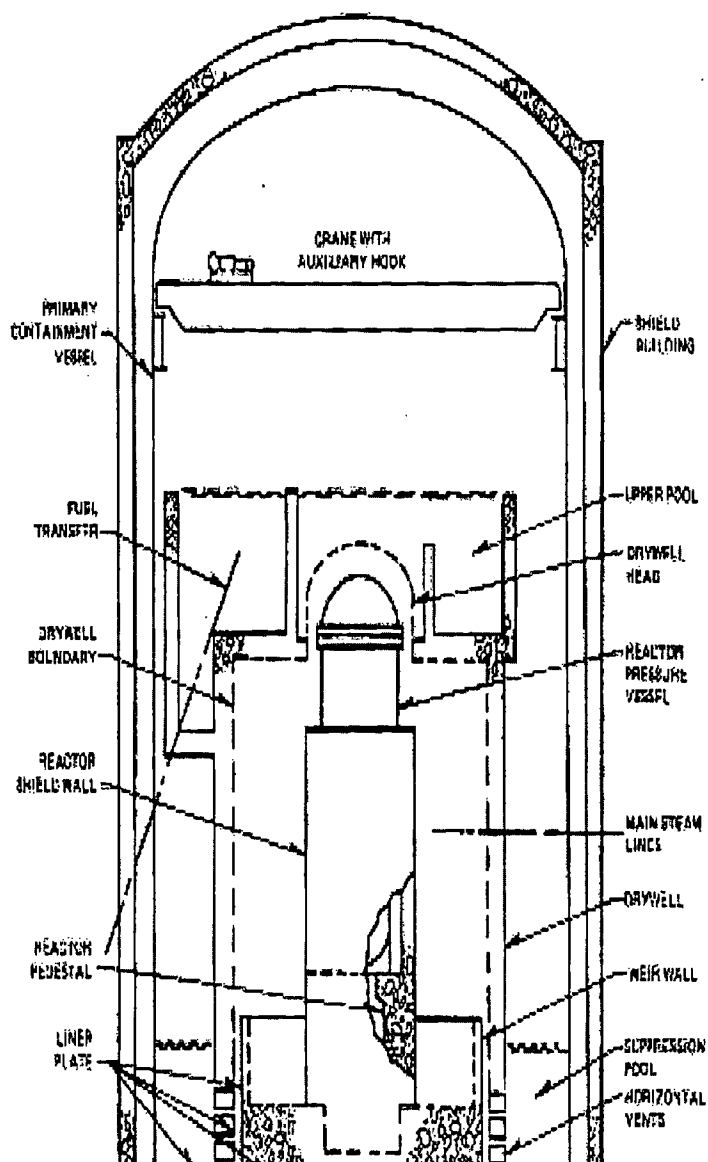

Drawings for Fukushima Units 1-4

■ Drawings are Available on Fukushima Units 1-4

- Lab Technical Team has received a set of 20 drawing for Fukushima Daiichi Units 1-4
 - *Mainly in Japanese*
- The reactors for Units 1, 2, and 6 were supplied by General Electric, those for Units 3 and 5 by Toshiba, and Unit 4 by Hitachi
- All six reactors were designed by General Electric. Architectural design for General Electric's units was done by Ebasco. All construction was done by Kajima. (source Wikipedia)

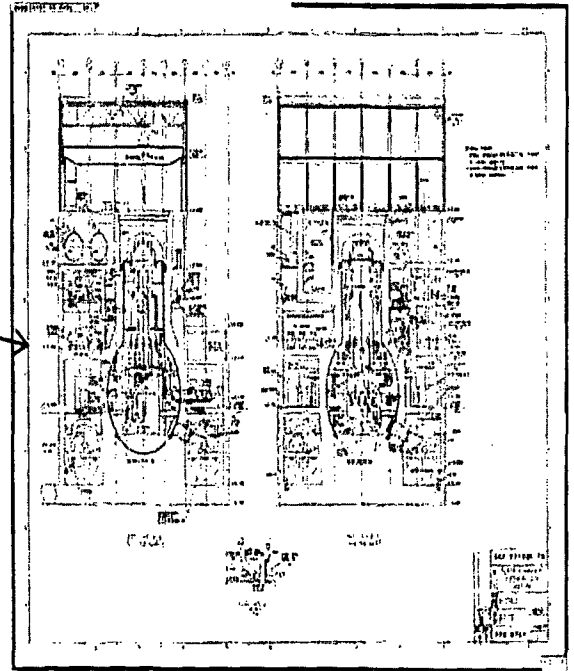

■ Important to have actual facility drawings for the 4 Units (examples)

- Understanding venting paths from containment
- Location of equipment for establishing short-term and long-term cooling
- Mapping radiation levels to understand worker dose issues during emergency and long-term response

■ Using other BWR Mark-I drawings may not be useful for detailed evaluation of emergency and long term response efforts because system design and locations change depending upon A/E firm.

Table 2.8 Plant differences affecting primary system and primary containment response to accident conditions

Item	Peach Bottom	Browns Ferry
DC power for diesel start, field flashing, and shutdown board control	From unit 125-V dc systems (two per unit)	Independent 125-V battery for each diesel; independent 250-V battery for each shutdown board
Safety/relief valves (SRVs)	11 three-stage Target Rock	13 two-stage Target Rock
Control air requirement for SRV opening as function of reactor vessel drywell pressure differential	26 psi at 150 psid 5 psi at 50 psid	0 psi at 1120 psid 25 psi at 0 psid
Control air requirement to hold an open valve open	5 psi	0 psi at 1120 psid 25 psi at 0 psid
Number of SRVs assigned to the automatic depressurization system (ADS)	Five	Six
Spring-loaded safety valves (discharge into drywell)	Two	None
Drywell control air system reliability	Long-term assured supply	Compressors lost at 2.45-psig drywell pressure; accumulators bleed down at 10 psig
RCIC system pump suction	Automatically shifted to pressure suppression pool on low CST level	No automatic shift
Size of feedpump startup bypass piping	3-in. (RFP A only)	8-in.
Condensate system pumps	Condensate pumps only	Condensate pumps and condensate booster pumps

❖ BWR MARK I

Fukushima I - 1
Below 500 MWe

Fukushima I - 2,3,4
800MWe

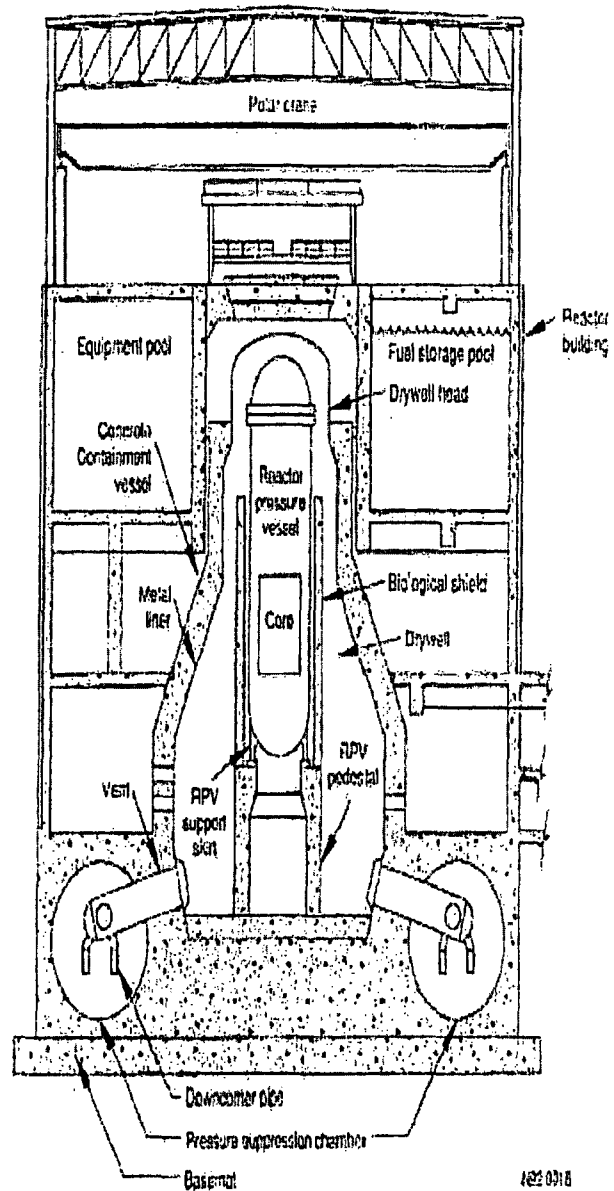
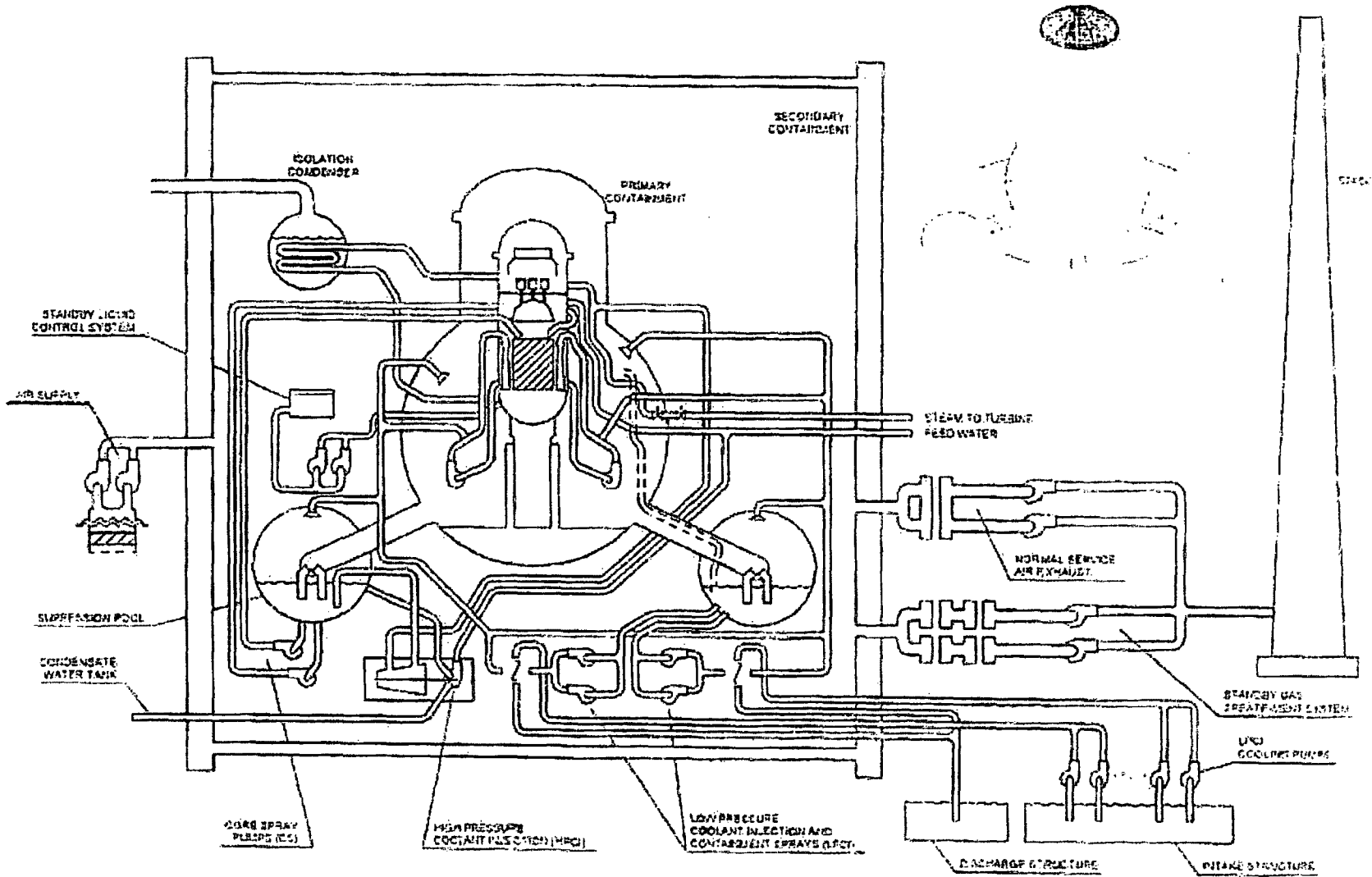

Figure 2.3-2: ECCS



RHR System



U.S. DEPARTMENT OF
ENERGY

Nuclear Energy

Peach Bottom (BWR4) Purge and Vent Valve Arrangement

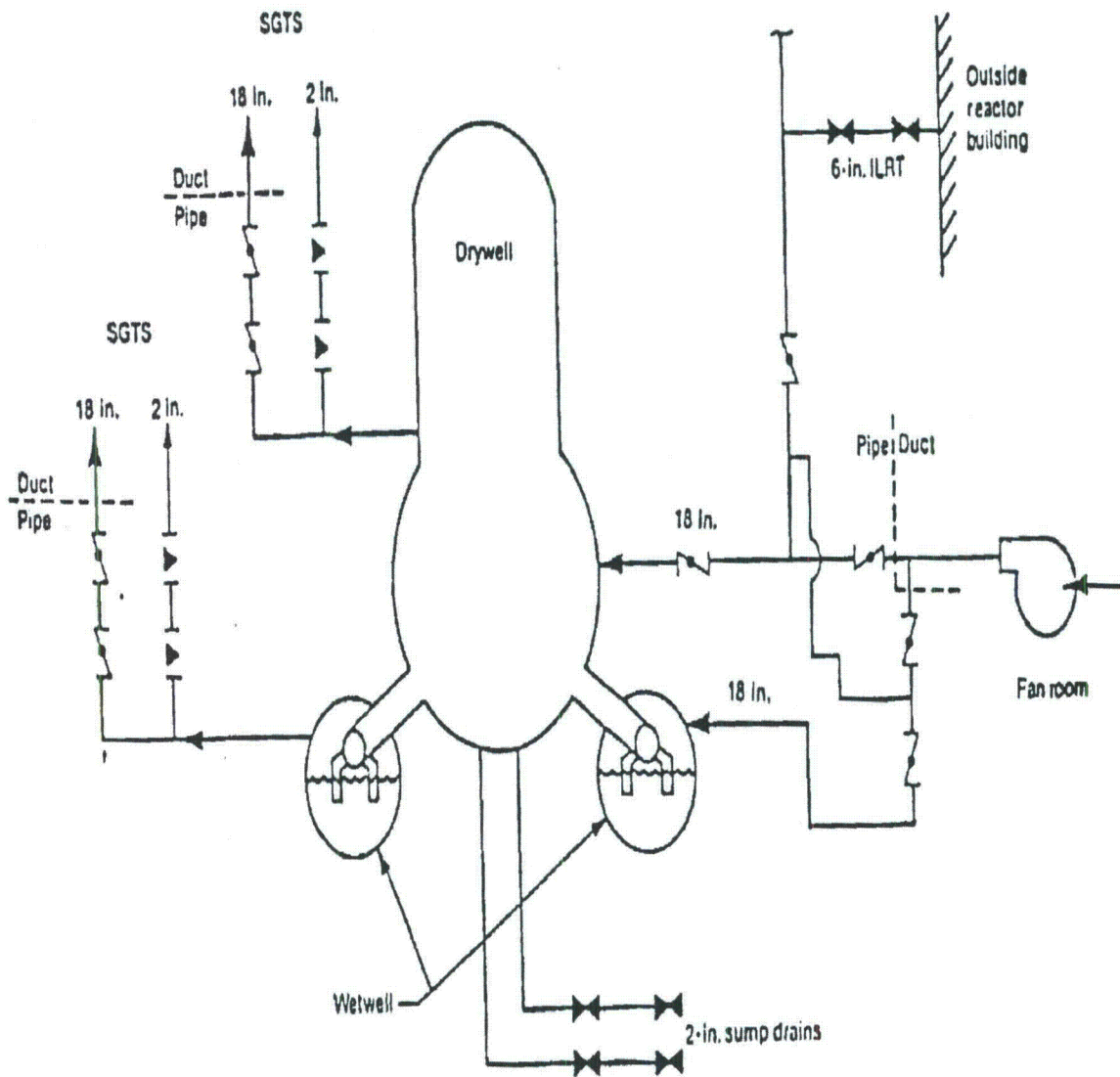

0 3228



U.S. DEPARTMENT OF
ENERGY

Nuclear Energy

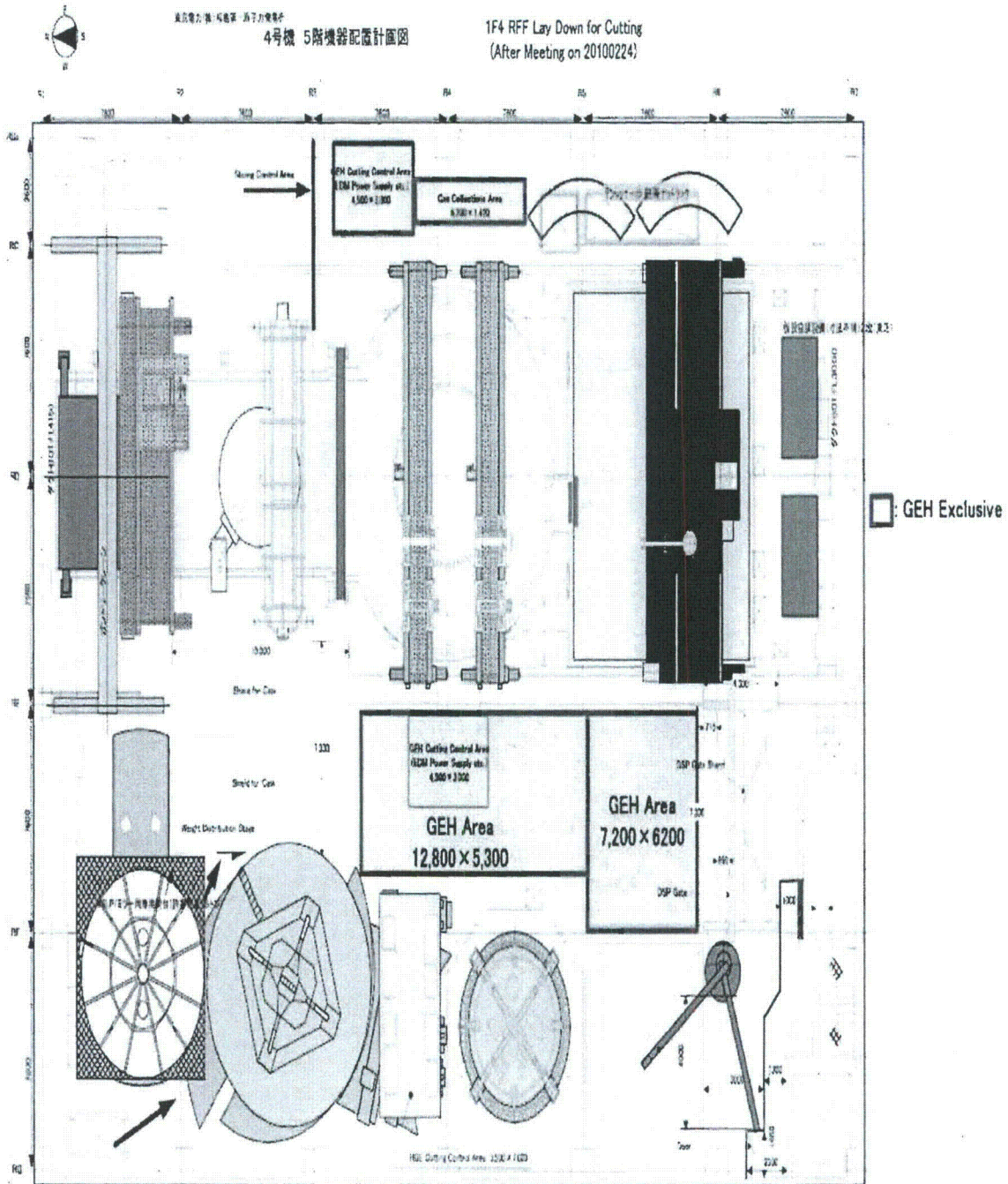



Containment Vent Paths (Peach Bottom)

Table 3.5 Containment Vent Paths (Peach Bottom)

2" Torus Vent Line Through SGTS

2" Drywell Vent Line Through SGTS

6" ILRT Line From the Torus

18" Torus Vent to SGTS

18" Torus Purge Supply Line

6" ILRT Line From the Drywell

18" Drywell Vent to SGTS

18" Drywell Purge Supply Line

2-3" Drywell Sump Drain Line



Impact of environmental variables for Fukushima

Table 11 Factors that affect corrosion of carbon steel immersed in seawater

Factor	Effect on iron and steel
Chloride ion	Highly corrosive to ferrous metals. Carbon steel and common ferrous metals cannot be passivated. Sea salt is about 55% chloride.
Electrical conductivity	High conductivity makes it possible for anodes and cathodes to operate over long distances; therefore, corrosion possibilities increase, and the total attack may be much greater than that for the same structure in freshwater.
Oxygen	Steel corrosion is cathodically controlled for the most part. Oxygen, by depolarizing the cathode, facilitates the attack; therefore, a high oxygen content increases corrosivity.
Velocity	Corrosion rate is increased, especially in turbulent flow. Moving seawater may destroy the rust barrier and provide more oxygen. Impingement attack tends to promote rapid penetration. Cavitation damage exposes fresh steel surfaces to further corrosion.
Temperature	Increased ambient temperature tends to accelerate attack. Heated seawater may deposit protective scale or lose its oxygen; either or both actions tend to reduce attack.
Biofouling	Hard-shell animal fouling tends to reduce attack by restricting access of oxygen. Bacteria can take part in the corrosion reaction in some cases.
Stress	Cyclic stress sometimes accelerates failure of a corroding steel member. Tensile stresses near yield also promote failure in special situations.
Pollution	Sulfides, which are normally present in polluted seawater, greatly accelerate attack on steel. However, the low oxygen content of polluted water could favor reduced corrosion.
Silt and suspended sediment	Erosion of the steel surface by suspended matter in the flowing seawater greatly increases the tendency toward corrosion.
Film formation	A coating of rust or rust and mineral scale (calcium and magnesium salts) will interfere with the diffusion of oxygen to the cathode surface, thus slowing the attack.

Source: Ref 107



U.S. DEPARTMENT OF
ENERGY

Nuclear Energy

The extent and mode of corrosion depends upon many variables

- In any environment, corrosion is complicated and depends on many variables
 - Material (alloy, state, load, load state)
 - Environment
 - Temperature
 - pH
 - Species present → Oxygen content!
 - Electrochemical potential
 - Geometry
 - Exposure time
- All are being influenced by current state in Fukushima cores
- Sea water will influence pH, species present (organics), and electrochemical potential.
- Structural and core materials will behave differently in this environment



U.S. DEPARTMENT OF
ENERGY

Nuclear Energy

Seawater is a complex environment by itself

Element	Reactor coolant (BWR, HWC)	Seawater (typical)
Calcium, ppm	0	400
Magnesium, ppm	0	1272
Sodium, ppm	0	10,561
Potassium, ppm	0	380
Lead, ppm	0	0.2
Chloride, ppm	<0.001	18,980
Bicarbonate, ppm	0	132
Flouride, ppm	0	3.5
Bromide, ppm	0	65
Sulfate, ppm	<0.003	2649
Silica, ppm	0	0.01 to 7.0
Carbon dioxide	0	6
Oxygen, ppm	<0.01	5
pH (at RT)	6.0	5.0

Summary of mechanisms and findings of Davis Besse Analysis

Material Loss Mechanisms

Matrix

PRELIMINARY		Extent of Wastage			
		Initial Tight Annulus	Enlarged Annulus	Small Cavity	Large Cavity
Possible Material Loss Mechanisms	Deaerated Boric Acid Corrosion Conc. Boric Acid Corrosion but DO ₂ = 0-10 ppb	Low rates			
	Dry BA or Boric Oxide Crystal Corrosion Corrosion in Contact with Dry Crystals and Humidity	Low rates			
	Single-Phase Erosion Potential Erosion if High Steam Velocities	Possible for high leak rates	Less likely than for tight annulus		Large flow area precludes high velocities
	Flow Accelerated Corrosion (FAC) Low-Oxygen Dissolution through Surface Oxides	Possible if liquid velocities high enough and temperature low enough			Unlikely as oxygen stabilizes
	Impingement / Flashing-Induced Erosion Droplet and Particle Impact Opposite Crack Outlet	Possible if droplets right size and momentum			
	Crevice Corrosion Liquid Ionic Path from Top Head Surface	Believed not to be likely because low alloy steel does not passivate in an aerated, concentrated boric acid			Not possible because no crevice geometry
	"Occluded Region" Galvanic Corrosion Driven by Potential Difference Btw Dissimilar Metals	Possible at locations where liquid solution exists			
	"Molten" Boric Acid Corrosion Corrosion in Pure or Nearly Pure Melted BA Crystals	Possible but rate expected to be lower than for aerated BAC			
	Aerated Boric Acid Corrosion (BAC) Concentrated Boric Acid Solution with Oxygen	Not possible due to low oxygen deep in crevice	Unlikely	Possibly	Up to 1-5 inches per year

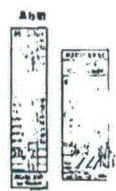
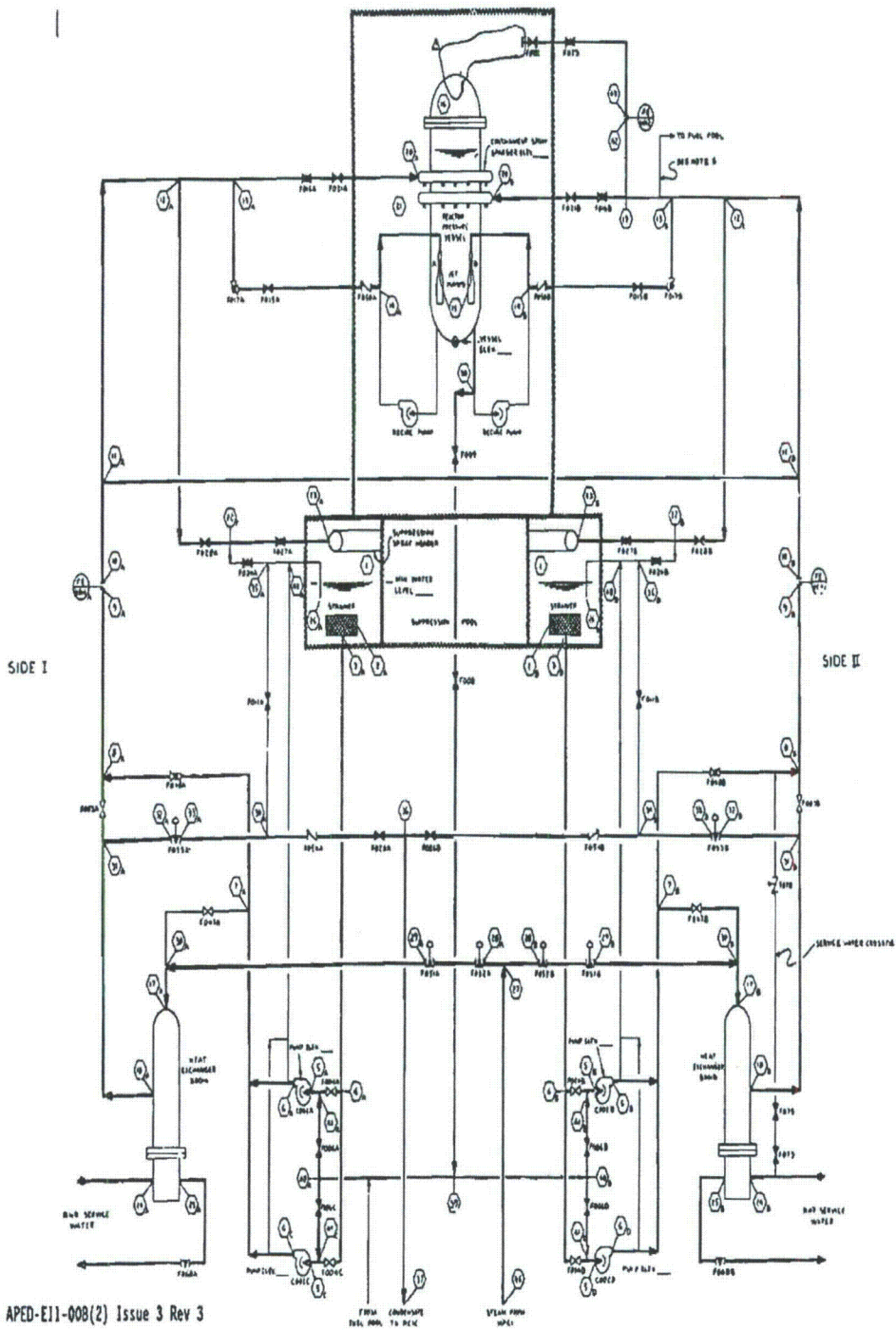

FROM E11-1020
 THE SUPPLEMENTAL TO THE P&ID HAS BEEN CHANGED FROM I.I. TO I.I. AS SHOWN IN THE ATTACHED WITH THE NEW WATER

DUANE ARNOLD ENERGY CENTER
 IOWA ELECTRIC LIGHT & POWER COMPANY
 UPDATED FINAL SAFETY ANALYSIS REPORT

P&ID, Residual Heat Removal System

Figure 6.3-3, Sheet 2

APED-E11-008(2) Issue 3 Rev 3

Revision 7 - 6/89



U.S. DEPARTMENT OF
ENERGY

Nuclear Energy

Decay Heat Power (MW_{th})

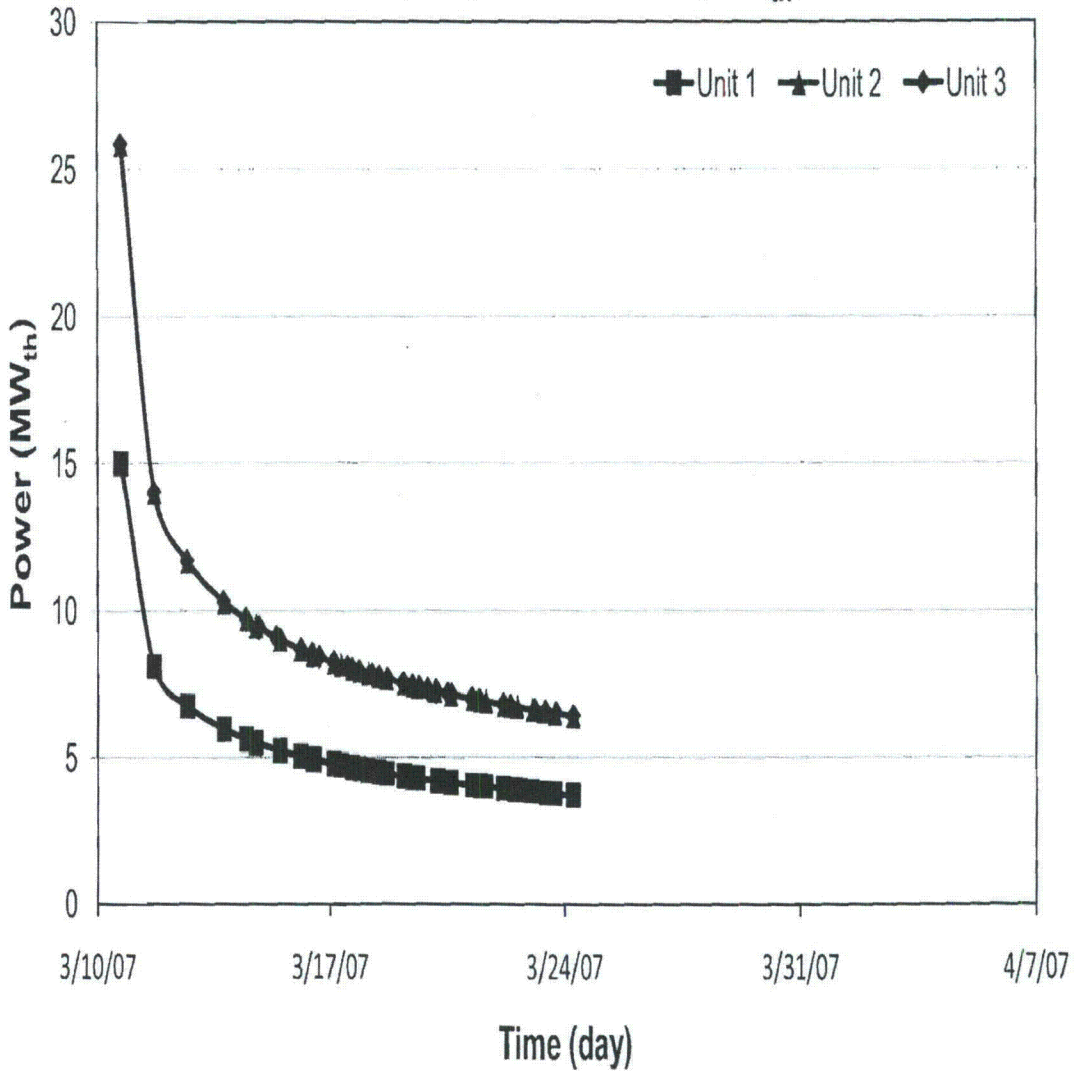



U.S. DEPARTMENT OF
ENERGY

Nuclear Energy

Cumulative Decay Heat Energy (GJ)

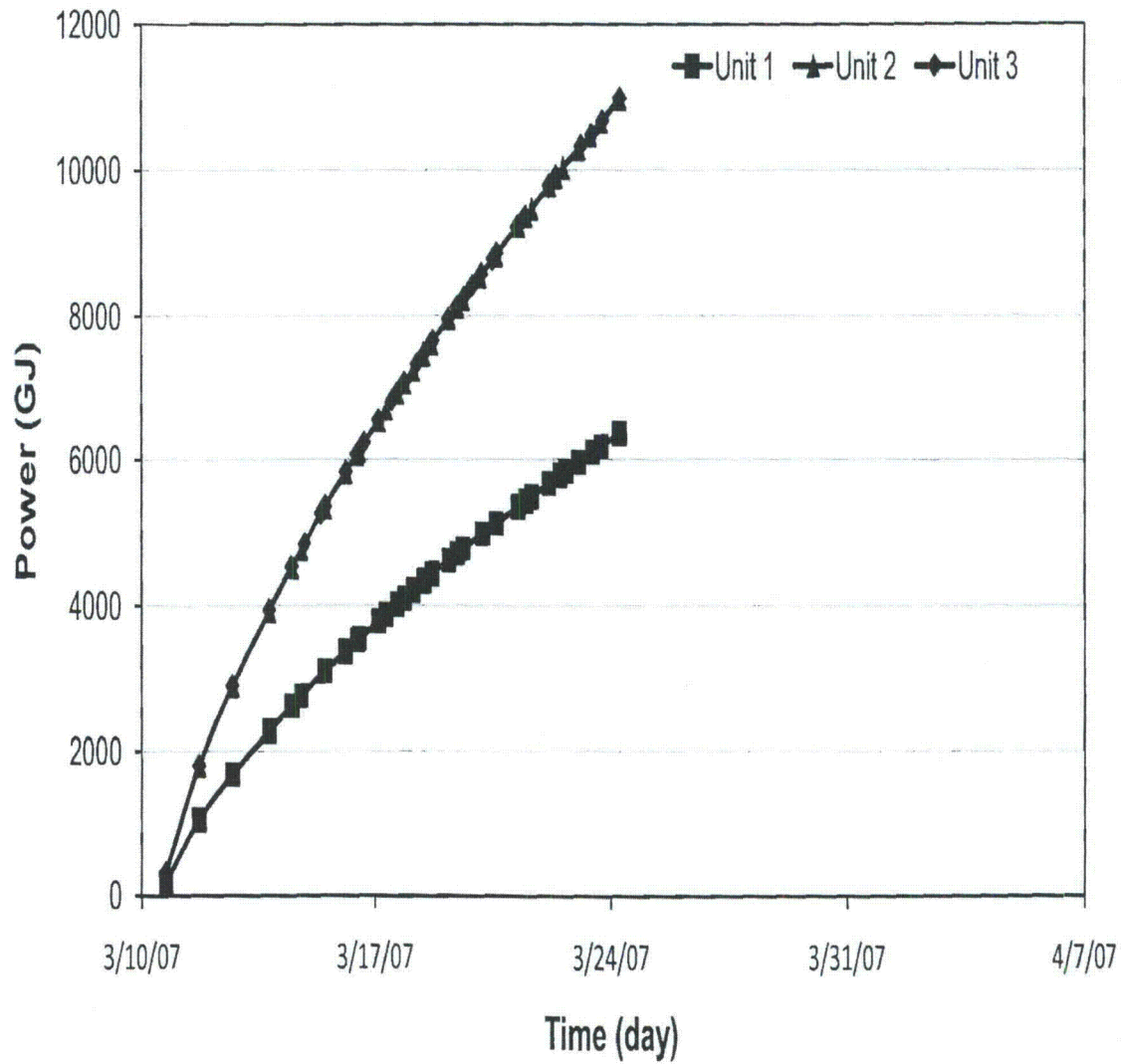



U.S. DEPARTMENT OF
ENERGY

Nuclear Energy

RPV Pressure

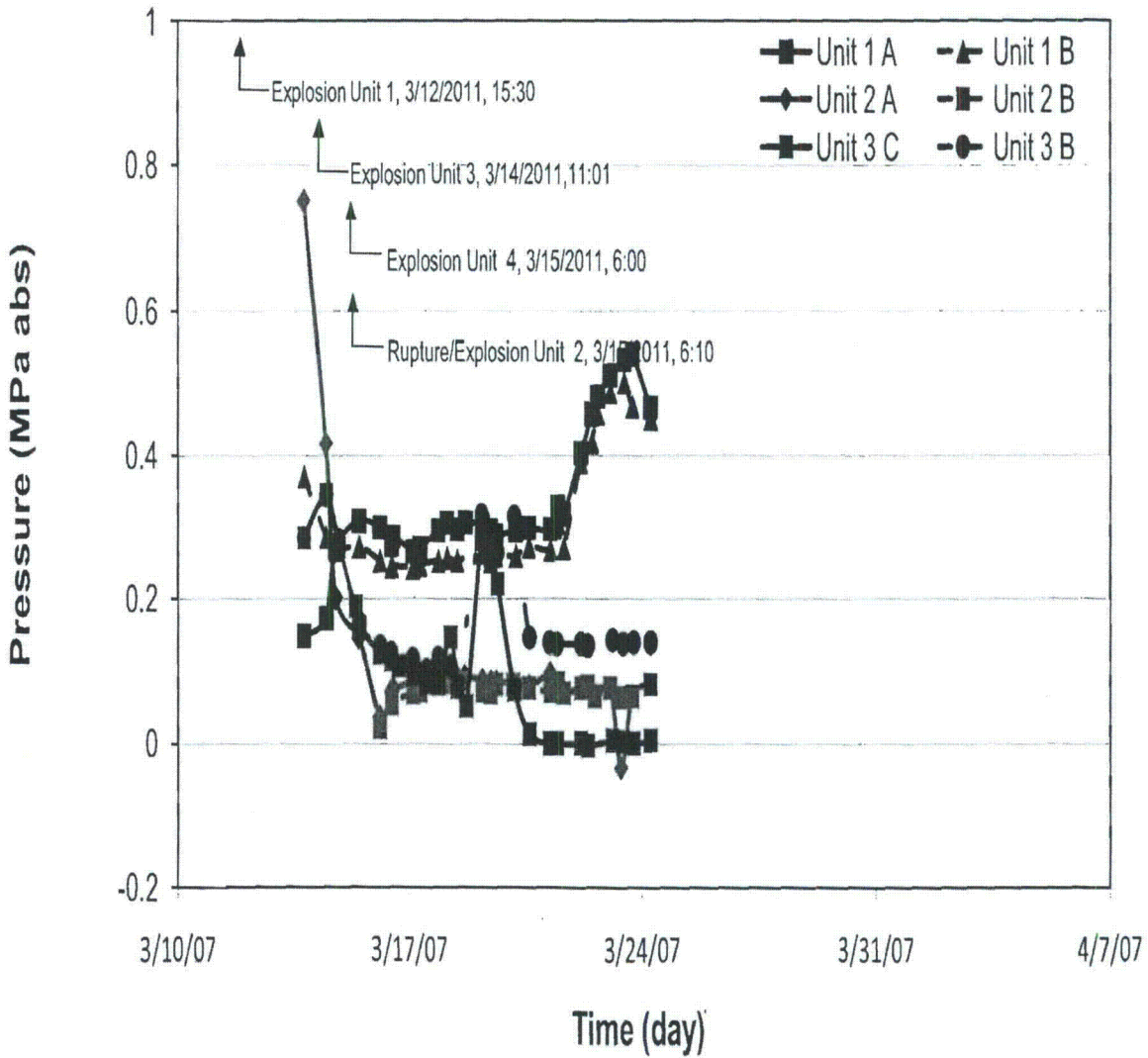



CV Pressure

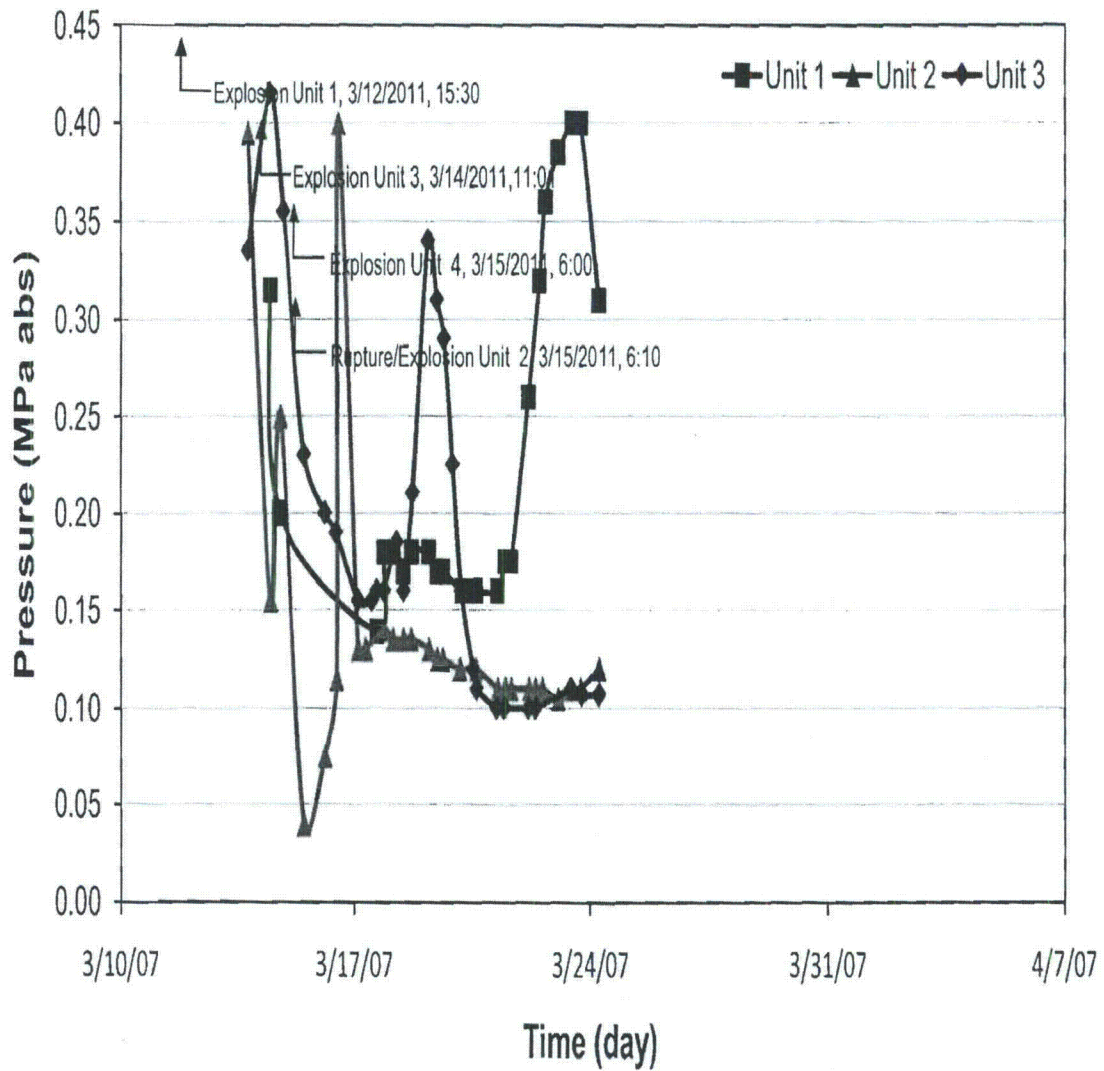



RPV Water Level (from top of core)

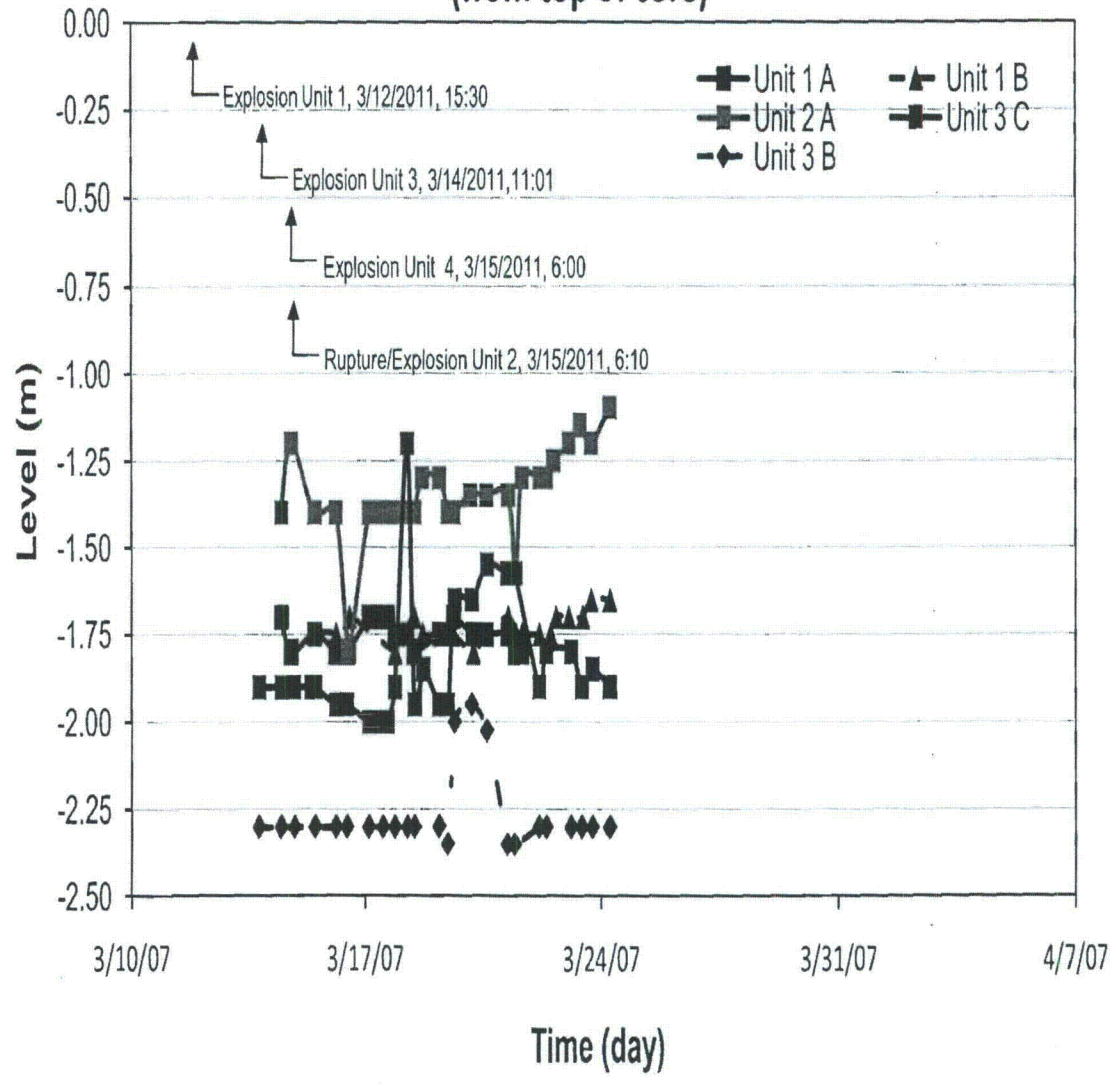



Spent Fuel Pool Temperature

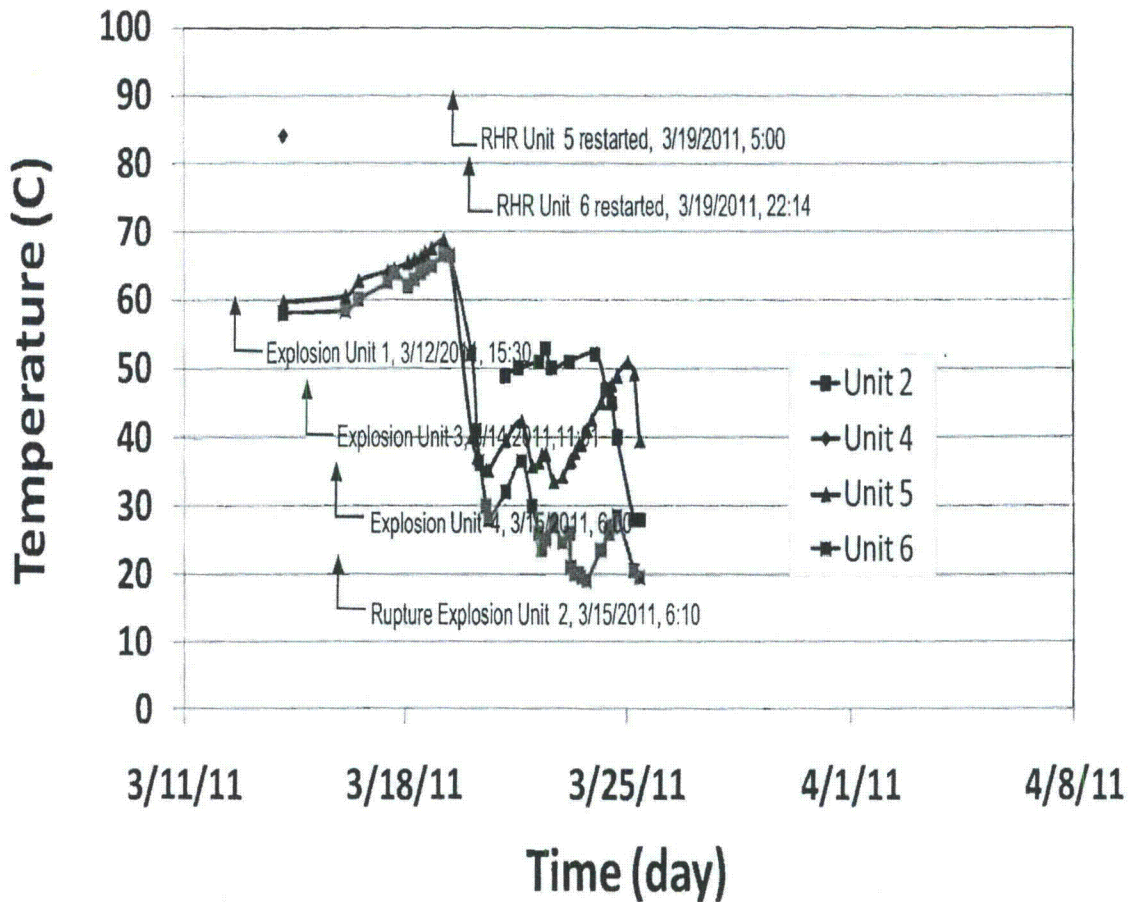



Feedwater Nozzle Temperature

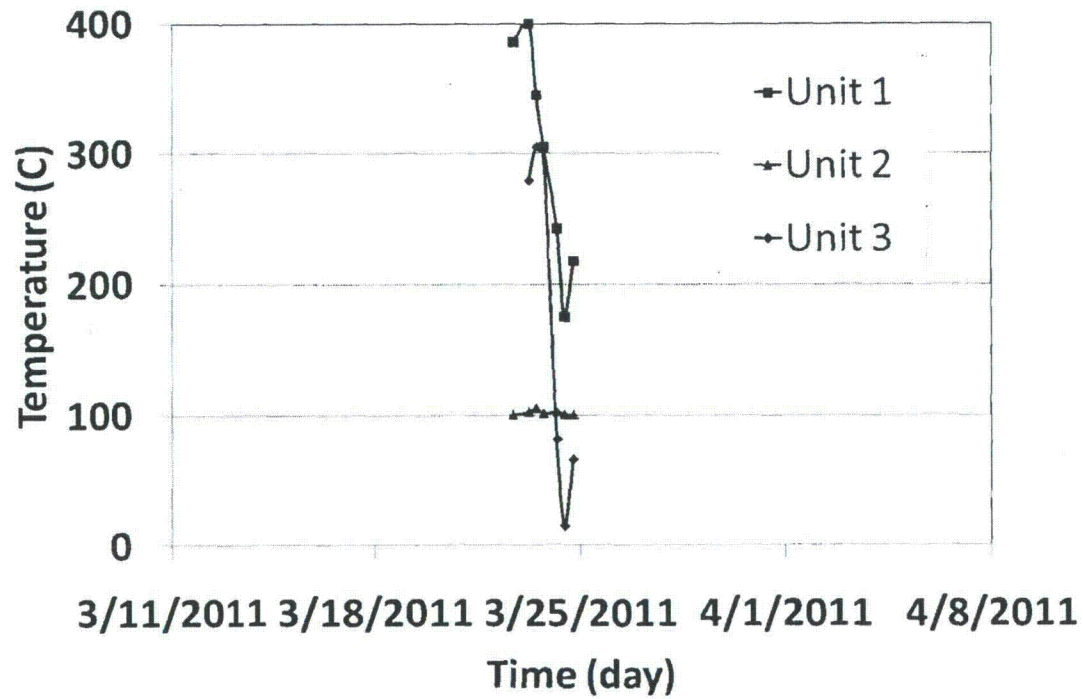



RPV Bottom Head Temperature

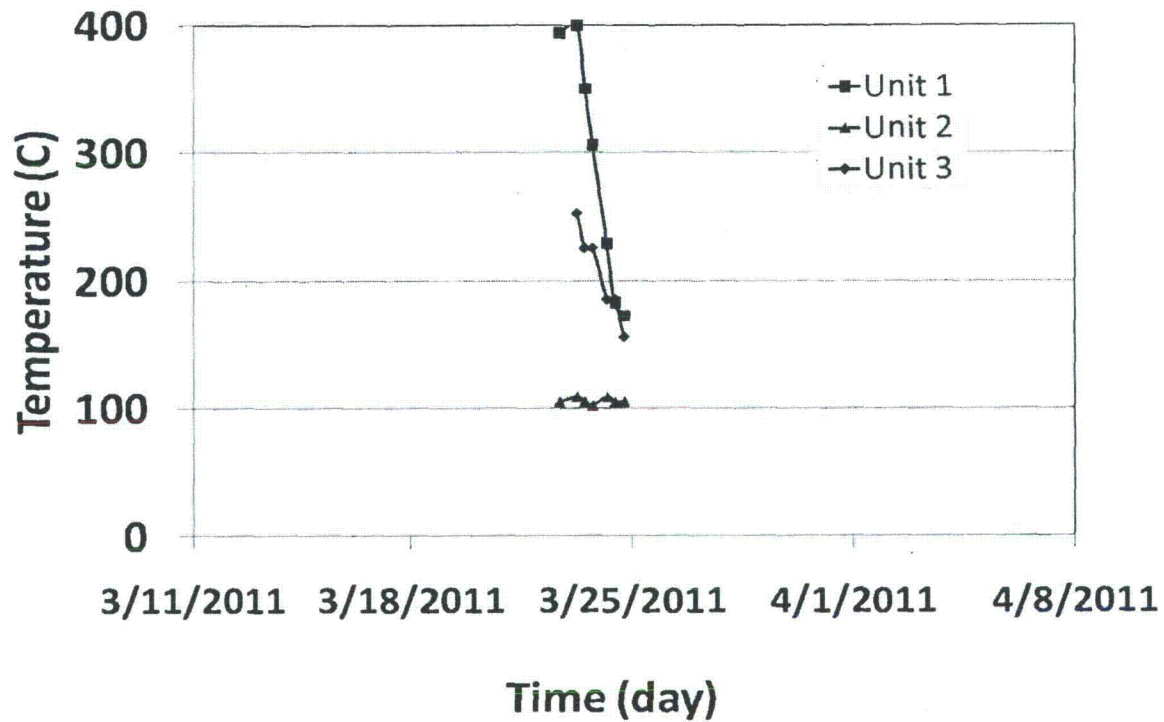



Spent Fuel Pool Injection

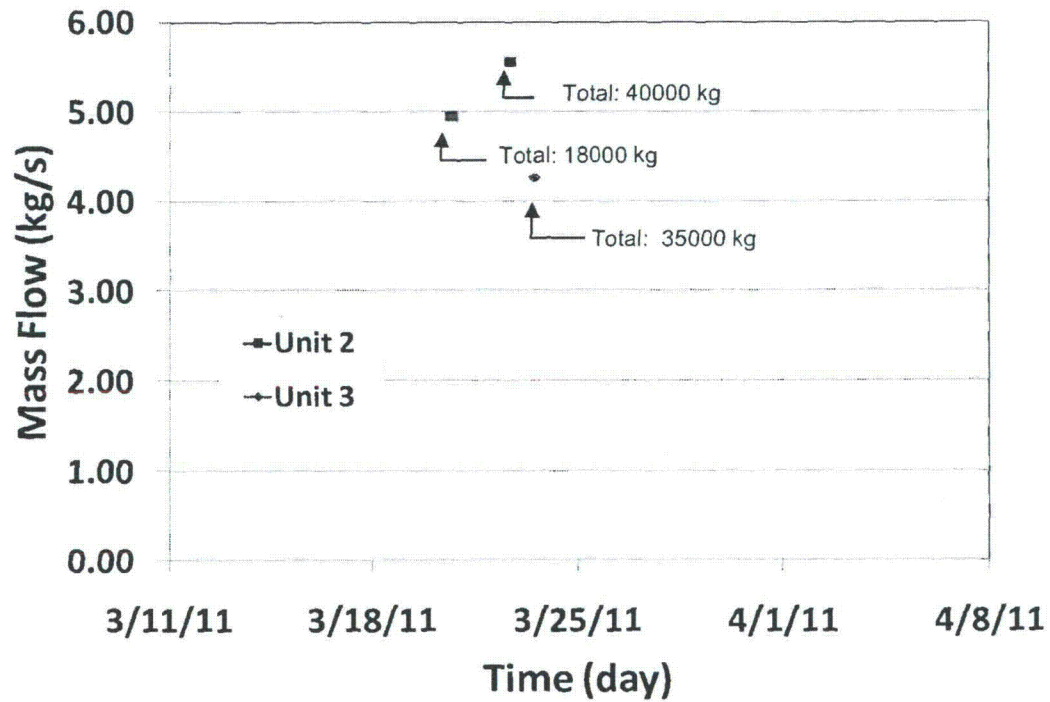



Spent Fuel Pool Spray

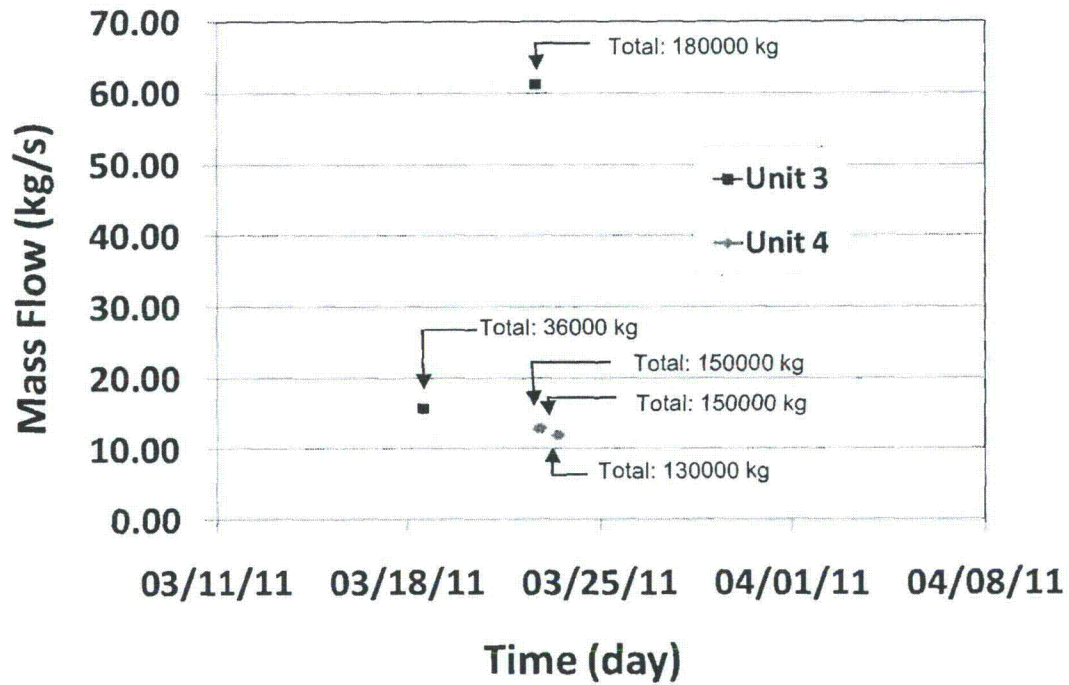



RPV Injection

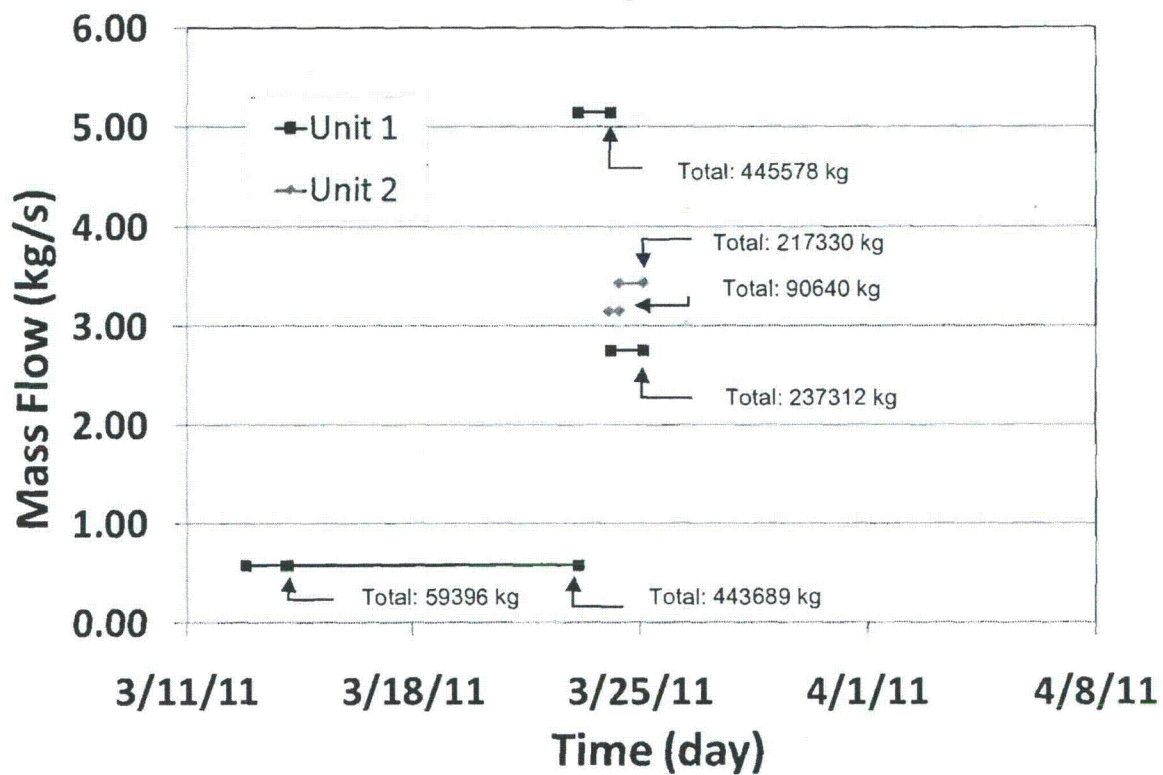



Radiological Survey Data 3/25/2011 (METI)

Reading of environmental radioactivity
level by prefecture 25th 8:00-9:00
(μ Sv/h)

Radiation in Daily-life

	Radiation dose (μ Sv)
Level to which a person exposed on average per year	3000
Chest X-ray examination	50
An air travel between Tokyo and New York (Round Trip)	200

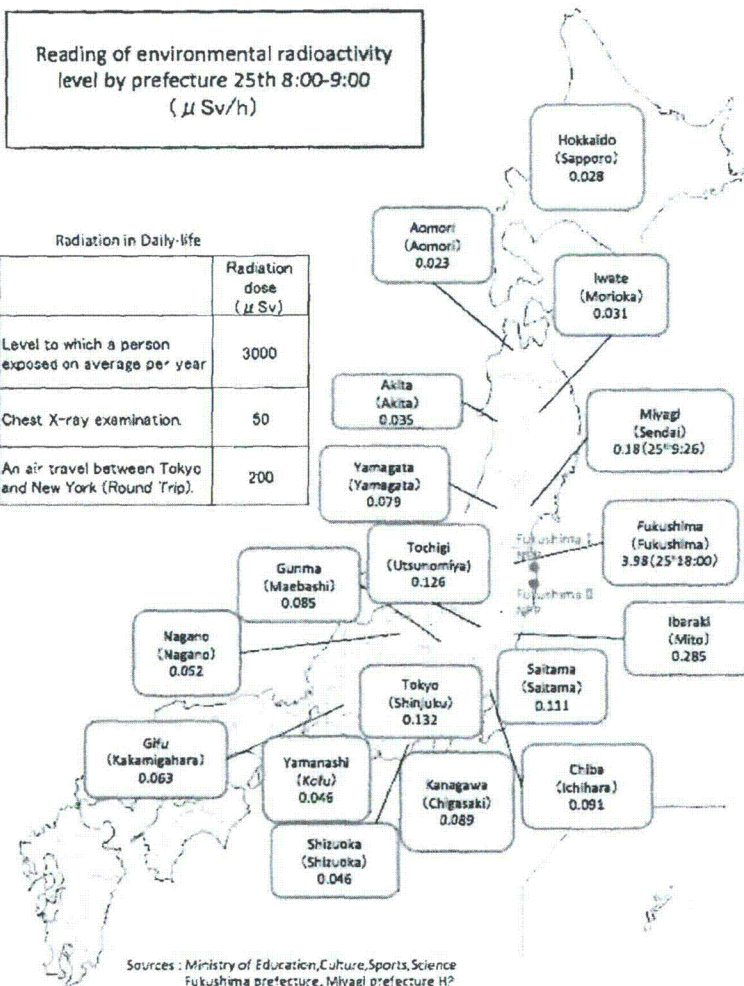

From: [Sheron, Brian](#)
To: [Lee, Richard](#)
Subject: FW: Science council presentation, 3/25
Date: Friday, March 25, 2011 4:56:00 PM
Attachments: [0325 Sec Briefing1-1.pptx](#)

From: Binkley, Steve [mailto:Steve.Binkley@science.doe.gov]
Sent: Friday, March 25, 2011 4:53 PM
To: 'david.hobbs@srl.doe.gov'; Adams, Ian; Aoki, Steven; Binkley, Steve; Bob Budnitz; Sheron, Brian; Brinkman, Bill; DAgostino, Thomas; Dick Garwin; Dick Garwin; Harold Denton; Harold McFarlane; Hurlbut, Brandon; John Grossenbacher; John Holdren; Kelly, John E (NE); Koonin, Steven; Lyons, Peter; Owens, Missy; Per Peterson; Phil Finck; Poneman, Daniel; Lee, Richard; Rolando Szilard; SCHU; Steve Fetter
Subject: FW: Science council presentation, 3/25

From: Kelly, John E (NE)
Sent: Friday, March 25, 2011 4:51 PM
To: Binkley, Steve
Subject: FW: Science council

From: Kelly, John E (NE)
Sent: Friday, March 25, 2011 4:42 PM
To: NITSolutions
Subject: Science council

slides for today

Dr. John E. Kelly
Deputy Assistant Secretary for Nuclear Reactor Technologies
NE-7
U.S. Department of Energy
1000 Independence Ave. SW
Washington, DC 20585
phone: 202-586-5458
fax: 202-586-0541
mobile: (b)(6)

CH/400



U.S. DEPARTMENT OF
ENERGY

Nuclear Energy

Peach Bottom (BWR4) Purge and Vent Valve Arrangement

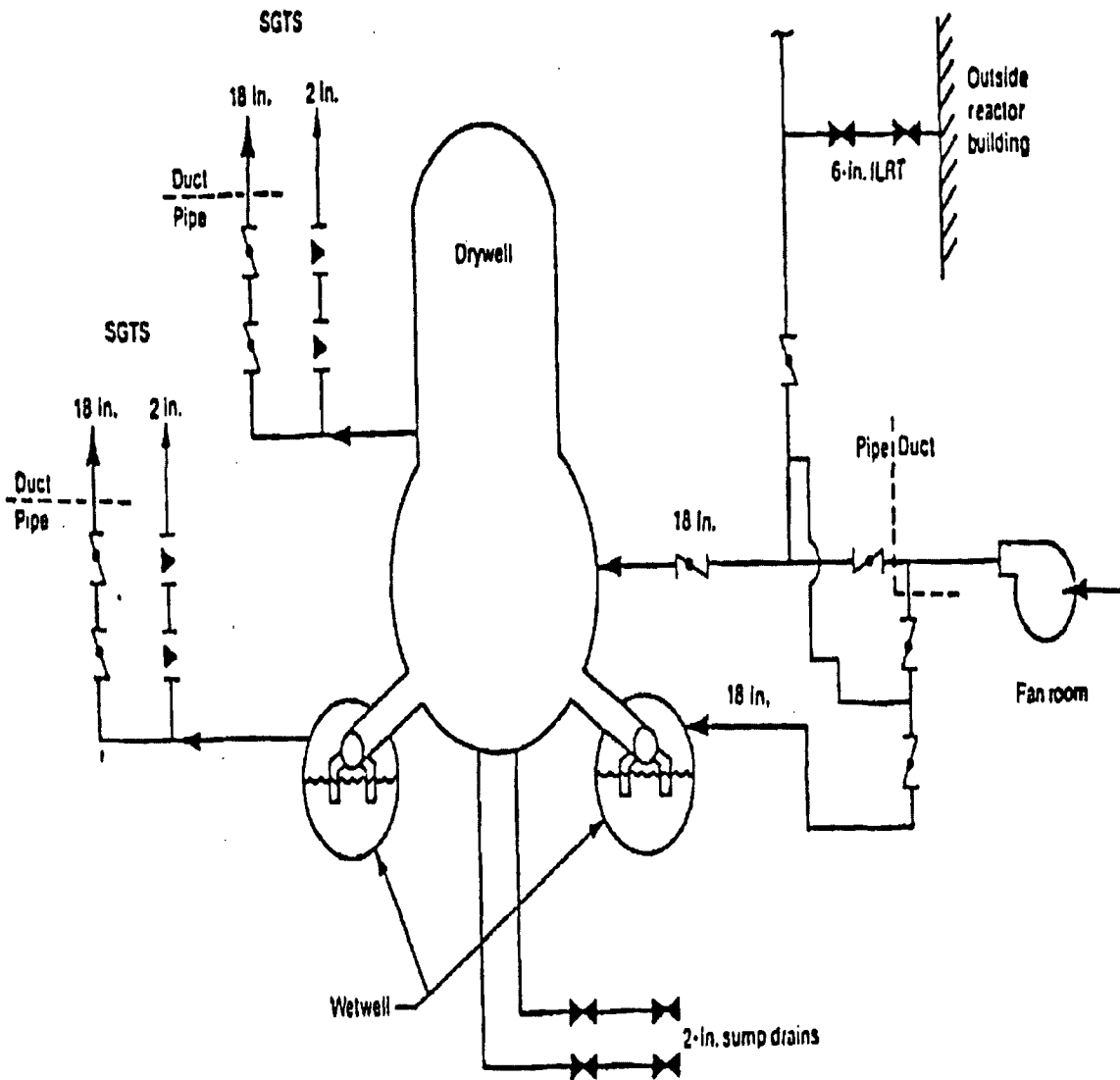

0 3228



U.S. DEPARTMENT OF
ENERGY

Nuclear Energy

Containment Vent Paths (Peach Bottom)

Table 3.5 Containment Vent Paths (Peach Bottom)

2" Torus Vent Line Through SGTS

2" Drywell Vent Line Through SGTS

6" ILRT Line From the Torus

18" Torus Vent to SGTS

18" Torus Purge Supply Line

6" ILRT Line From the Drywell

18" Drywell Vent to SGTS

18" Drywell Purge Supply Line

2-3" Drywell Sump Drain Line



Impact of environmental variables for Fukushima

Table 11 Factors that affect corrosion of carbon steel immersed in seawater

Factor	Effect on iron and steel
Chloride ion	Highly corrosive to ferrous metals. Carbon steel and common ferrous alloys cannot be passivated. Sea salt is about 55% chloride.
Electrical conductivity	High conductivity makes it possible for anodes and cathodes to operate over long distances; therefore, corrosion possibilities increase, and the total attack may be much greater than that for the same structure in freshwater.
Oxygen	Steel corrosion is cathodically controlled for the most part. Oxygen, by depolarizing the cathode, facilitates the attack; therefore, a high oxygen content increases corrosivity.
Velocity	Corrosion rate is increased, especially in turbulent flow. Moving seawater may destroy the rust barrier and provide more oxygen. Impingement attack tends to promote rapid penetration. Cavitation damage exposes fresh steel surfaces to further corrosion.
Temperature	Increased ambient temperature tends to accelerate attack. Heated seawater may deposit protective scale or lose its oxygen; either or both actions tend to reduce attack.
Biofouling	Hard-shell animal fouling tends to reduce attack by restricting access of oxygen. Bacteria can take part in the corrosion reaction in some cases.
Stress	Cyclic stress sometimes accelerates failure of a corroding steel member. Tensile stresses may yield also promote failure in special situations.
Pollution	Sulfides, which are normally present in polluted seawater, greatly accelerate attack on steel. However, the low oxygen content of polluted water could favor reduced corrosion.
Silt and suspended sediment	Erosion of the steel surface by suspended matter in the flowing seawater greatly increases the tendency toward corrosion.
Film formation	A coating of rust or rust and mineral scale (calcium and magnesium salts) will interfere with the diffusion of oxygen to the cathode surface, thus slowing the attack.

Source: Ref 107



U.S. DEPARTMENT OF
ENERGY

Nuclear Energy

The extent and mode of corrosion depends upon many variables

- In any environment, corrosion is complicated and depends on many variables
 - Material (alloy, state, load, load state)
 - Environment
 - Temperature
 - pH
 - Species present → Oxygen content!
 - Electrochemical potential
 - Geometry
 - Exposure time
- All are being influenced by current state in Fukushima cores
- Sea water will influence pH, species present (organics), and electrochemical potential.
- Structural and core materials will behave differently in this environment



U.S. DEPARTMENT OF
ENERGY

Nuclear Energy

Seawater is a complex environment by itself

Element	Reactor coolant (BWR, HWC)	Seawater (typical)
Calcium, ppm	0	400
Magnesium, ppm	0	1272
Sodium, ppm	0	10,561
Potassium, ppm	0	380
Lead, ppm	0	0.2
Chloride, ppm	<0.001	18,980
Bicarbonate, ppm	0	132
Flouride, ppm	0	3.5
Bromide, ppm	0	65
Sulfate, ppm	<0.003	2649
Silica, ppm	0	0.01 to 7.0
Carbon dioxide	0	6
Oxygen, ppm	<0.01	5
pH (at RT)	6.0	5.0

Summary of mechanisms and findings of Davis Besse Analysis

Material Loss Mechanisms

Matrix

PRELIMINARY		Extent of Wastage			
		Initial Tight Annulus	Enlarged Annulus	Small Cavity	Large Cavity
Possible Material Loss Mechanisms	Deaerated Boric Acid Corrosion Conc. Boric Acid Corrosion but DO ₂ = 0-10 ppb	Low rates			
	Dry BA or Boric Oxide Crystal Corrosion Corrosion in Contact with Dry Crystals and Humidity	Low rates			
	Single-Phase Erosion Potential Erosion if High Steam Velocities	Possible for high leak rates	Less likely than for tight annulus		Large flow area precludes high velocities
	Flow Accelerated Corrosion (FAC) Low-Oxygen Dissolution through Surface Oxides	Possible if liquid velocities high enough and temperature low enough			Unlikely as oxygen stabilizes
	Impingement / Flashing-Induced Erosion Droplet and Particle Impact Opposite Crack Outlet	Possible if droplets right size and momentum			
	Crevice Corrosion Liquid Ionic Path from Top Head Surface	Believed not to be likely because low alloy steel does not passivate in an aerated, concentrated boric acid			Not possible because no crevice geometry
	"Occluded Region" Galvanic Corrosion Driven by Potential Difference Btw Dissimilar Metals	Possible at locations where liquid solution exists			
	"Molten" Boric Acid Corrosion Corrosion in Pure or Nearly Pure Melted BA Crystals	Possible but rate expected to be lower than for aerated BAC			
	Aerated Boric Acid Corrosion (BAC) Concentrated Boric Acid Solution with Oxygen	Not possible due to low oxygen deep in crevice	Unlikely	Possibly	Up to 1-5 inches per year

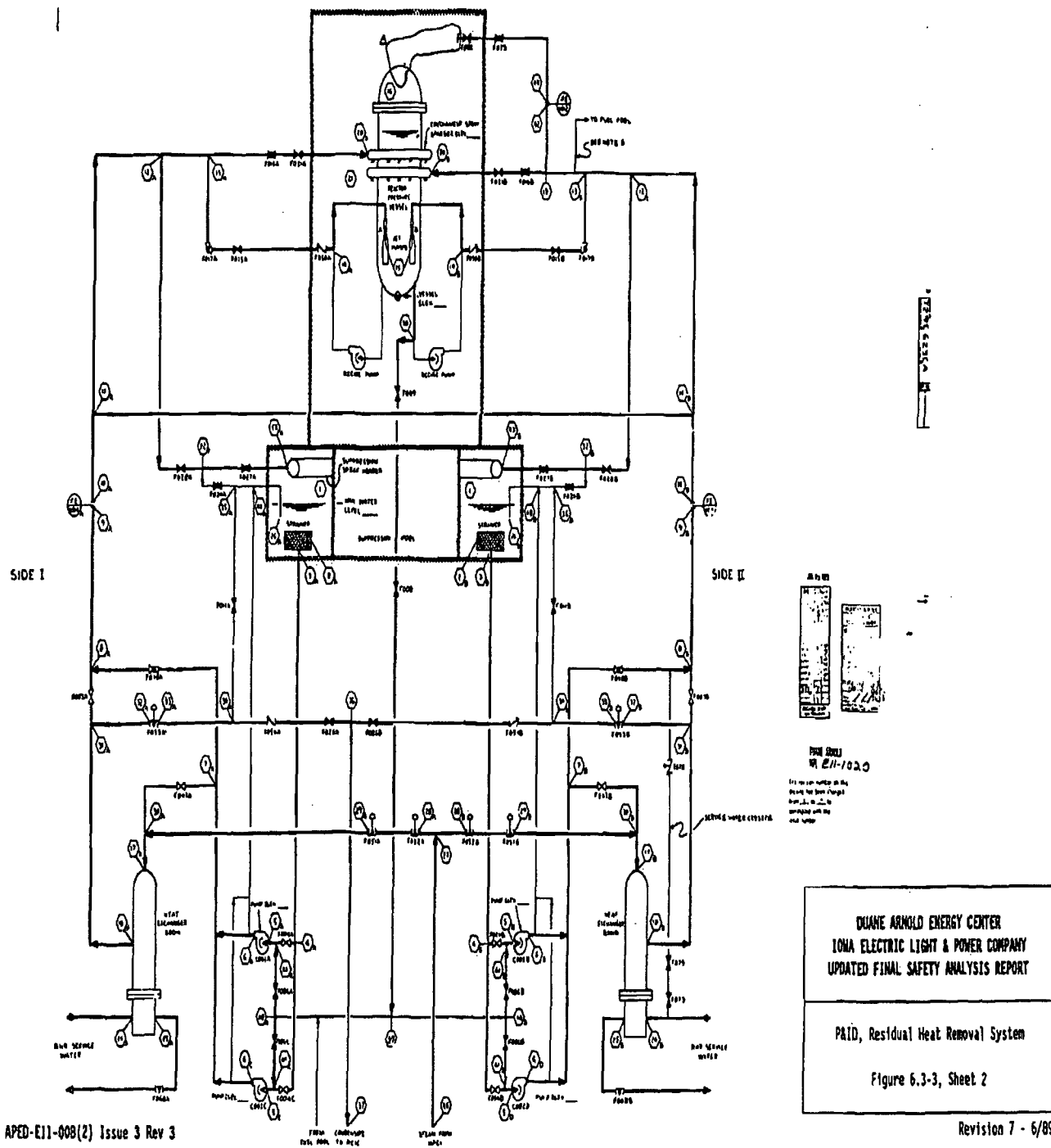

APED-E11-008(2) Issue 3 Rev 3

Revision 7 - 6/89

From: [Sheron, Brian](#)
To: [ET05 Hoc](#)
Cc: [Giitter, Joseph](#)
Subject: RE: Priority for Fukushima-Daiichi Units
Date: Friday, March 25, 2011 4:57:00 PM

Thanks. I already received these from MJ and forwarded them to OCA to give to the house staffers.

From: ET05 Hoc
Sent: Friday, March 25, 2011 4:56 PM
To: Sheron, Brian
Cc: Giitter, Joseph
Subject: RE: Priority for Fukushima-Daiichi Units

I'm forwarding on the closeout notes for the previous set of Congressional questions. I'm not sure that they made it your way. This is what we have in the system:

The following information taken from the IAEA website and answers the first two questions:

As per the IAEA, three workers at the Fukushima Daiichi nuclear power plant were exposed on 24 March to elevated levels of radiation. The IAEA has received additional information on the incident from the Japanese authorities.

The three were contracted workers laying cables in the turbine building of the Unit 3 reactor. Two of them were found to have radioactivity on their feet and legs.

These were washed in the attempt to remove radioactivity, but since there was a possibility of Beta-ray burning of the skin, the two were taken to the Fukushima University Hospital for examination and then transferred to Japan's National Institute of Radiological Sciences for further examination. They are expected to be monitored for around four days.

It is thought that the workers ignored their dosimeters' alarm believing it to be false and continued working with their feet in contaminated water.

The Nuclear and Industrial Safety Agency (NISA) of Japan instructed TEPCO to review the radiation control system immediately in order to avoid similar incidents in the future.

As of 24 March, 19:30 Japan time, the number of workers at the Fukushima Daiichi nuclear power plant found to have received more than 100 millisieverts of radiation dose totalled 17 including the three contract workers. The remaining fourteen are TEPCO's employees.

PMT's response for Q3 is as follows:

3) Per the Japanese regulator, through the site team...No quantitative cause analysis exists, but decay of iodine itself or reduction in rainfall with iodine, or their combination can be a plausible reason for the decrease in Iodine levels in the Tokyo drinking water.

Regards,
Melissa Ralph
Melissa.Ralph@nrc.gov
ET Actions Officer (et05.hoc@nrc.gov)
NRC Headquarters Operation Center

CH/401

From: Sheron, Brian
Sent: Friday, March 25, 2011 4:42 PM
To: ET05 Hoc
Subject: RE: Priority for Fukushima-Daiichi Units

Great, thanks.

From: ET05 Hoc
Sent: Friday, March 25, 2011 4:23 PM
To: Sheron, Brian
Subject: FW: Priority for Fukushima-Daiichi Units

Good afternoon,

In answer to your question about the change in priorities, I'm attaching information from our Reactor Safety Team. This information will be added to the SITRep. Please let me know if there's anything else I can help you with. There is a task entered into the tracker for response to all of the congressional questions that you passed along through the HOOs.

Regards,
Melissa Ralph
Melissa.Ralph@nrc.gov
ET Actions Officer (et05.hoc@nrc.gov)
NRC Headquarters Operation Center

From: RST01 Hoc
Sent: Friday, March 25, 2011 4:19 PM
To: ET05 Hoc
Subject: Priority for Fukushima-Daiichi Units

Per Joe Giiter's request:

Per John Thorp, RST Communicator, at 2319 on 3/24/11:

Updated the Fukushima Daiichi Status Summary, based on the RST Assessment Report identified in the prior entry. The main source of information for the table has not been updated, but the Assessment report and the analysis by the RST during its development led to a decision to assign a revised priority to Units 1 through 4. Unit 1 is priority 1 based on the fact that primary containment integrity can still be preserved, if the responders take the correct actions to inject to the RPV and Primary containment. Unit 2 is priority 2 because of the apparent damage to primary containment and the other barriers to release, requiring continued attention to cool the core and provide water to the primary containment to minimize potential for release. Unit 3 is priority 3, because primary containment may be OK but continued attention is required to pursue core cooling and

injection. Unit 4 is priority 4 because of progress in addressing the spent fuel pool heat removal requirements, and indicated SFP area temperatures of less than 100degrees C.

Brett Rini
RST Coordinator

From: [Adams, Ian](#)
To: [Adams, Ian](#); [Aoki, Steven](#); [Binkley, Steve](#); [Budnitz, Bob](#); [Sheron, Brian](#); [Brinkman, Bill](#); [Garwin, Dick \(EQP\)](#); [Garwin, Dick \(IBM\)](#); [Finck, Phillip](#); [Grossenbacher, John \(INL\)](#); [Hurlbut, Brandon](#); [John Holdren](#); [Kelly, John E \(NE\)](#); [Koonin, Steven](#); [Lyons, Peter](#); [McFarlane, Harold](#); [Owens, Missy](#); [Peterson, Per](#); [SCHU](#); [Steve Fetter](#); [Szilard, Ronaldo](#)
Subject: FW: Science council
Date: Friday, March 25, 2011 5:01:55 PM
Attachments: [0325 Sec Briefing1-1.pptx](#)

Apologies for the redundancy – just wanted to make sure everyone gets today’s slides.

Ian

CH/402

From: [Lee, Richard](#)
To: [Sheron, Brian](#)
Subject: RE: Science council presentation, 3/25
Date: Friday, March 25, 2011 5:03:10 PM

Thx, Got it.

From: Sheron, Brian
Sent: Friday, March 25, 2011 4:56 PM
To: Lee, Richard
Subject: FW: Science council presentation, 3/25

From: Binkley, Steve [<mailto:Steve.Binkley@science.doe.gov>]
Sent: Friday, March 25, 2011 4:53 PM
To: 'david.hobbs@srl.doe.gov'; Adams, Ian; Aoki, Steven; Binkley, Steve; Bob Budnitz; Sheron, Brian; Brinkman, Bill; DAGostino, Thomas; Dick Garwin; Dick Garwin; Harold Denton; Harold McFarlane; Hurlbut, Brandon; John Grossenbacher; John Holdren; Kelly, John E (NE); Koonin, Steven; Lyons, Peter; Owens, Missy; Per Peterson; Phil Finck; Poneman, Daniel; Lee, Richard; Rolando Szilard; SCHU; Steve Fetter
Subject: FW: Science council presentation, 3/25

From: Kelly, John E (NE)
Sent: Friday, March 25, 2011 4:51 PM
To: Binkley, Steve
Subject: FW: Science council

From: Kelly, John E (NE)
Sent: Friday, March 25, 2011 4:42 PM
To: NITSolutions
Subject: Science council

slides for today

Dr. John E. Kelly
Deputy Assistant Secretary for Nuclear Reactor Technologies
NE-7
U.S. Department of Energy
1000 Independence Ave. SW
Washington, DC 20585
phone: 202-586-5458
fax: 202-586-0541
mobile: (b)(6)

CH/403

From: Chan, Deborah
To: RES Distribution
Subject: PMDA Weekly Notes: 11-12
Date: Friday, March 25, 2011 5:12:49 PM
Attachments: [image001.png](#)
[image002.emz](#)
[image003.png](#)
[image004.png](#)
[image005.png](#)
[image006.png](#)

PMDA Weekly Notes: 11-12 (3/25/11)

Contact: Debbie Chan at 301-251-7466

For all FO/PMDA Staff: Response to FOIA Request from the Associated Press due Wednesday, March 30 (See e-mail of 3/25/11 from Brett Rini). Contact: Brett Rini or Jazel Parks *NEW*

For all PMDA Staff: PMDA All-Hands Meeting – Wednesday, March 30, 1:30 – 3:00 p.m., Room 6B01 *NEW*

;

RES Arriving Employees

Rich Correia, from NRR to DRA, 3/28/11
Kenn Miller, from NRR to DE/MEEB, 3/28/11

RES Departing Employees

None

Current RES Vacancies

Technical Assistant, DE, GG-14 Posted 3/17 – 4/5/11
Administrative Assistant, DE, GG-7/8 Posted 3/15 – 4/5/11

April

A Probabilistic Risk Assessment View of Consequential Steam Generator Tube Rupture
Date: April 19

CH/404

Time: 10:00 a.m. – 11:30 a.m.
Place: TWFN Auditorium
Presenters: Selim Sancaktar (DE)

Chernobyl – 25th Anniversary Seminar

Date: April 26

Time: 9:30 a.m. – 11:30 a.m.

Place: TWFN Auditorium

Presenters: Introduction by Mike Weber, Deputy EDO for Materials, Waste, Research and State, Tribal and Compliance Programs and presentations by Frank Congel, Former Director, Division of Incident Response Operations, NSIR and Former Director, OE; and Brian Sheron, Director, RES

Work Schedule and Premium Pay Guidance for Response to Events in Japan *NEW*

NRC has implemented various work schedule and premium pay flexibilities as it strives to accommodate the challenging and often unpredictable work schedule and premium pay needs of employees responding to events in Japan.

HR has posted the [Work Schedule and Premium Pay Guidance](#) on its intranet page and expects to add frequently asked questions. Based on questions received so far, HR notes that:

- For employees on a NEWFlex schedule, HRMS will not accept more than 11.25 hours of regular work per day. Any amount worked beyond that on a single work day must be entered as overtime or compensatory time worked rather than regular time. (Employees on Expanded Compressed schedules may work more than 11.25 regular hours per day.)
- The maximum number of credit hours that an employee may carry over from one pay period to the next remains 24 credit hours. This is restricted by a government wide rule.
- Although the guidance applies to Senior Executive Service members (executives), executives remain ineligible for premium pay or credit hours as a matter of government wide law.

Please see your timekeepers for questions. For further information about selecting work schedules and authorizing premium pay for responders, please contact [Lawrence.Davidson](#), 301-492-2286.

Interim Guidance for Placing and Monitoring of Work with Department of Energy (DOE) Laboratories *NEW*

On March 14, 2011, the Executive Director for Operations issued a memorandum (ML110110581) providing interim guidance for enhanced oversight of the process for placing work with DOE laboratories consistent with recommendations from the Office of the Inspector General. The interim guidance is effective immediately and requires offices to submit Source Selection Justifications (SSJ) in the following cases to the Division of Contracts (DC) for independent review to ensure commercial sources are fully considered:

- **New projects** with a value > \$500K
- **Modifications** involving a change > 20% in the initial ceiling of the basic agreement previously reviewed by DC

DC has 5 business days to review the SSJ and respond. If no response is received from DC within this timeframe, RES may proceed with the project or modification as submitted. Please contact Eddie Colón at 301-251-3302 if you have any questions.

Microsoft Windows 7 and Office 2010 Migration Effort

Software Testing Requirements

The Office of Information Services (OIS) will be migrating NRC workstations in FY 2012 to a new Microsoft Windows 7 platform w/ Office 2010. To ensure a smooth transition, OIS is requiring that all agency desktop applications, custom developed software, and any other commercial applications or add-ins that are currently in use on an NRC workstation be tested and approved through the Consolidated Test Facility (CTF) by no later than Friday, July 29, 2011. Any software that is not tested during this period will not be approved for use on the new Windows 7 platform.

OIS is offering two ways for staff to test their software. The CTF, located at White Flint in room T-5E32, has five workstations with Microsoft Windows 7 installed for staff to use and validate their software. OIS is also providing staff with a remote testing feature so they can perform their tests from their office computers.

Prior to conducting these tests, staff will be required to install their software on the Windows 7 platform provided.

All software testing conducted must be scheduled using scheduling software on the following OIS Web site: <http://portal.nrc.gov/edo/ois/icod/ddb/MSW7/default.aspx>

RES has also arranged to have someone from OIS meet with staff to answer any questions they may have about this effort. This meeting is currently scheduled for:

Tuesday, March 29, 2011

11am – 12:00pm (CSB 2-C19)

If you have further questions regarding this matter, please contact the RES IT coordinator on 301.251.8498 or RESHelpDesk@nrc.gov.

Call Forward Instructions for Church Street

Call Forwarding is now available at the Church Street Building. The Call Forward feature is programmed and acts in the same way as the Off-Net Call Forward feature that is available in the other Headquarters locations. This feature allows a user to choose to reroute incoming calls to a telephone number that is internal or external to the agency telephone system. The RES staff is reminded that Management Directive 2.3, "Telecommunications," provides agency policy on the use of telephones.

Call Forwarding can only be activated or deactivated at the desktop telephone unit.

Call Forward Universal (CFU) Instructions

To activate Call Forward:

- Remove handset or press speaker to get dial-tone.
- Enter line feature code (*731) to deactivate any previous programming.

To forward your phone, please do the following:

- Enter *721, listen for dial tone, and then enter 9-XXX-XXX-XXXX. You must dial the "9" to complete the call to the external telephone number. To forward to an internal telephone number, enter 251-XXXX.
- Listen for stutter tone, and the number you dialed will ring. You may now hang up. Your call forwarding is active.

Be Aware: There is no visible or audible reminder that the phone forward feature is enabled. So, please remember to disable if you no longer wish to use it.

To deactivate Call Forward:

- Remove handset or press speaker to get dial-tone.
- Enter line feature code (*731) to deactivate any previous programming.
- Listen for a stutter tone. This will indicate your deactivation was successful.

NOTE: Every time you activate the Call Forward feature, you must enter *731 to ensure that you have removed all previous programming on your telephone number before proceeding to input the new CFU programming.

Please contact the RES help desk, ResHelpDesk.Resource@nrc.gov, for any assistance or contact Shane Rupinta, 301-251-7992.

Voice Mail Forwarding Instructions

This is the procedure to forward your voicemail messages to an alternate phone number(s).

1. Lift the handset off your phone or hit the SPKR (Speaker) button.
2. Press the voicemail button to connect to the voicemail system (301.881.1549) and when the system answers, type in your pin #
3. Select option 4 (Mailbox options)
4. Select option 4 (Notification Options)
5. Select option 3 (Activate message delivery options)
6. Select option 1 (Enable/disable option) enter in the phone number followed by the # sign

To deactivate this option repeat steps 1-6 but when executing step 6 select option 1 to disable the option.

Please contact the RES help desk, ResHelpDesk.Resource@nrc.gov, for any assistance or contact John Wucher, 301-251-7960.

FY11 Personally Identifiable Information (PII) Responsibilities Awareness and Acknowledgement of Understanding Course

The Office of Information Services (OIS) is pleased to announce the availability of the FY11 "Personally Identifiable Information (PII) Responsibilities Awareness and Acknowledgement of Understanding" course in iLearn <https://ilearnnrc.plateau.com/plateau/user/login.jsp> as of January 31, 2011. This course has been automatically assigned to your iLearn Learning Plan.

All employees and contractors must be aware of their responsibilities for protecting PII, understand the consequences for violation of these responsibilities, and acknowledge these understandings at least annually. The completion date for this required training is **June 30, 2011**.

When completing the training outside of headquarters, users should not use CITRIX to access iLearn as this may cause completion issues. Offsite users should navigate to the [iLearn Web site](#).

If you have any questions regarding completion of the training, please contact me via e-mail deonna.purdie@nrc.gov or via phone 301-251-7470.

FY11 Annual Computer Security Awareness Course

All NRC computer users, including federal employees, detailees, interns, and contractors, are required to complete this computer security awareness course annually. The completion date for this course is **August 15, 2011; however, each office must have a percentage of their users complete the course each quarter starting with 2nd quarter**. For more information about the course, [click here](#). The course has been automatically added to your learning plan. Go to [iLearn](#) to complete the course.

Market Research Course (Web-Based)

The new online Market Research course is now available in iLearn at <https://ilearnnrc.plateau.com/plateau/user/login.jsp>. This course replaces the Acquisition Institute's Market Research (CLC004) course and is required for Federal Acquisition Certification for Contracting Officer Technical Representatives (FAC-COTR) (i.e., RES Project Managers). To access the course, perform a "Search Catalog" in iLearn by entering "Market Research." The course will take about 1 hour to complete. The final exam is comprised of 10 questions, of which at least 8 must be answered correctly. You have unlimited attempts to obtain 80 percent, which is required to pass the course. NRC Project Managers assigned to active contracts must complete the additional training courses required for FAC-COTR and must be certified no later than **June 30, 2011**. Please contact Carolyn Cooper in Division of Contracts at 301-492-3605 if you have any questions or experience problems with the course.

None

From: Gibson, Kathy
To: Rubin, Stuart
Cc: Dehn, Jeff; Sheron, Brian
Subject: RE: China HTGR Alignment
Date: Friday, March 25, 2011 5:20:21 PM
Attachments: Kathy Halvey Gibson2.vcf

Thanks Stu!

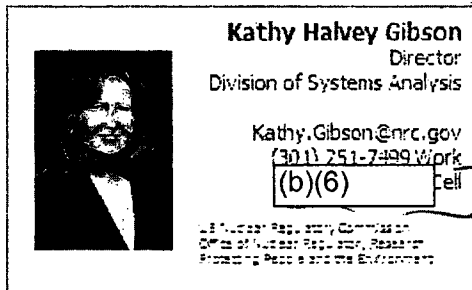

From: Rubin, Stuart
Sent: Friday, March 25, 2011 5:04 PM
To: Gibson, Kathy
Subject: RE: China HTGR Alignment

I can attend the meeting.

From: Gibson, Kathy
Sent: Friday, March 25, 2011 4:52 PM
To: Rubin, Stuart; Zaki, Tarek
Cc: Hoxie, Chris
Subject: FW: China HTGR Alignment
Importance: High

Can you attend this meeting Monday at 10 am? I will not be here.

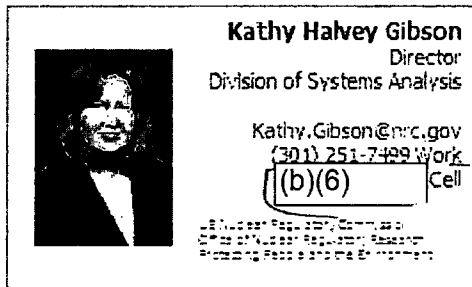

From: Dehn, Jeff
Sent: Friday, March 25, 2011 4:47 PM
To: Sheron, Brian
Cc: Uhle, Jennifer; Gibson, Kathy; Scott, Michael; Rubin, Stuart; Sangimino, Donna-Marie; Basu, Sudhamay; Zaki, Tarek
Subject: China HTGR Alignment

Brian, All,

CH/405

F (b)(5)

Thank you,
Jeff

Jeff Dehn

International Relations Specialist
Office of Nuclear Regulatory Research (RES)
US Nuclear Regulatory Commission
jeff.dehn@nrc.gov
301-251-7672
C-6D22

From: Araguas, Christian
To: Araguas, Christian; Dorman, Dan; Haney, Catherine; NMSS TA; Holahan, Gary; Johnson, Michael; NRO Deputy Division Directors; NRO Division Directors; NRO TA; Boger, Bruce; Grobe, Jack; Leeds, Eric; Wertz, Trent; Correia, Richard; Diec, David; Dudek, Michael; Layton, Michael; McDermott, Brian; Miller, Chris; Shropshire, Alan; Wiggins, Jim; Burns, Stephen; Jones, Bradley; Zabler, Marian; Armstrong, Kenneth; Coe, Doug; Gibson, Kathy; Hudson, Daniel; Lui, Christiana; Santiago, Patricia; Sheron, Brian; Uhle, Jennifer; Sanfilippo, Nathan; Zaki, Tarek; Basu, Sudhamay; Scott, Michael; Montgomery, Shandeth; Raione, Richard; Tiruneh, Nebiyu; Vrahoretis, Susan; Kirkwood, Sara; Roach, Edward; NRO DSRA Branch Chiefs; Schmidt, Jeffrey; Caruso, Mark; Landry, Ralph; Dube, Donald; Rasmussen, Richard; Peralta, Juan; Kowal, Mark; Beardsley, James; Junge, Michael; Coffin, Stephanie; Giacinto, Joseph; Cozens, Ian; Ray, Neil; Weber, Carl; Norato, Michael; Wright, Lisa (Gibney); Lockhart, Denise
Cc: Maquider, Stewart; Reckley, William; Mayfield, Michael; NRO ARP ARB2 Distribution; NRO ARP ARB1 Distribution
Subject: Advanced Reactor Program (ARP) Weekly Update- Week of March 28, 2011.
Date: Friday, March 25, 2011 5:27:06 PM
Attachments: ARP Internal Stakeholder Weekly Update.docx

All,

Attached is the list of upcoming internal / external meetings related to advanced reactors. In an effort to keep our internal stakeholders informed of upcoming advanced reactor activities, this document will be sent weekly. Please let me know if you would like to be removed from the list or if I should be including anyone else. Thanks.

For those that are interested, this document will be located on the Advanced Reactor Sharepoint site at the link provided below,
<http://epm.nrc.gov/Licensing/Advanced%20Reactor%20Program/default.aspx>. You should see the file under the links section on the right hand column.

Christian Araguas
Technical Assistant
Advanced Reactor Program
Office of New Reactors

CH/406

ARP WEEKLY UPDATE
Week of March 28, 2011

Significant Meetings in CY 2011

Internal Meetings:

- ARP All Hands Meeting March 28, 2011
- Commission Meeting on SMRs March 29, 2011
- ACRS Full Committee Meeting on Emergency Planning for SMRs April 7, 2011

Periodic Meetings:

- NRC/NEI SMR Periodic Workshop April 20, 2011
- NRC/NEI SMR Periodic Workshop May 25, 2011
- NRC/NEI SMR Periodic Workshop July 13, 2011

iPWR Meetings:

- mPower Meetings
 - IST Facility and Test Plan / Design Basis LOCA PIRT Insights/Results April 19, 2011
 - ECCS Design / Fuel Assembly Mechanical Design June 21, 2011
- NuScale Meetings

NGNP Meetings:

LMR Meetings:

Conferences:

- Building the Value Chain for Commercializing SMRs (Infocast/Washington DC) March 30-31, 2011
- International Framework for Nuclear Cooperation April 19-21, 2011
- 1st Annual SMR Conference – Organized by Nuclear Energy Insider April 19-20, 2011
- ICAPP Meeting (ANS/Nice, France) May 2-5, 2011
- Platts SMR Conference May 23-24, 2011

Significant Activities

From: Sheron, Brian
To: (b)(6)
Subject: RE: Re: Other Stuff
Date: Friday, March 25, 2011 5:32:00 PM

Said the man who works at NIH!

From: martinwb [mailto:(b)(6)]
Sent: Friday, March 25, 2011 5:14 PM
To: Sheron, Brian
Subject: Re: Re: Other Stuff

(b)(6)

Marriage is a wonderful invention. But, then again, so is the bicycle repair kit.

?

Mar 25, 2011 09:30:17 AM, Brian.Sheron@nrc.gov wrote:

(b)(5)

From: (b)(6)
To: Sheron, Brian
Sent: Fri Mar 25 09:13:01 2011
Subject: Re: Other Stuff

(b)(6)

?

Mar 25, 2011 06:18:33 AM, Brian.Sheron@nrc.gov wrote:

(b)(6)

CH/407

Paul

From: Sheron, Brian [mailto:Brian.Sheron@nrc.gov]

Sent: Sunday, March 20, 2011 8:58 PM

To: Paul Richardson; 'Frank Koch'

Cc: (b)(6)

Subject: RE: (b)(6)

(b)(6)

From: Paul Richardson (b)(6)

Sent: Friday, February 25, 2011 3:01 PM

To: 'Frank Koch'; Sheron, Brian

Cc: (b)(6)

Subject: (b)(6)

Brian,

(b)(6)

Best regards,

Paul

From: Frank Koch (b)(6)

Sent: Friday, February 25, 2011 1:52 PM

To: brian.sheron; paul.richardson

Cc: (b)(6)

Subject: RE: (b)(6)

Brian

(b)(6)

Frank

From: Brian.Sheron@nrc.gov

To: (b)(6)

Date: Tue, 22 Feb 2011 11:36:44 -0500

Subject: (b)(6)

(b)(6)

Brian

From: Sheron, Brian
To: Bonaccorso, Amy; Calvo, Antony; Case, Michael; Coe, Doug; Correia, Richard; Dion, Jeanne; Gibson, Kathy; Lui, Christiana; Richards, Stuart; Rini, Brett; Sangimino, Donna-Marie; Uhle, Jennifer; Valentin, Andrea
Subject: FW: Tomorrow's News Tonight - READ & DELETE
Date: Friday, March 25, 2011 5:33:00 PM

From: Hayden, Elizabeth
Sent: Friday, March 25, 2011 5:29 PM
To: Brenner, Eliot
Subject: Tomorrow's News Tonight - READ & DELETE

~~Internal use only - no distribution outside NRC - no redistribution internally~~
~~May contain material proprietary to news agencies~~

1: DIABLO CANYON – We spoke with reporters from KSBY and KEYT in San Luis Obispo, Ca., and the Spokane (Wa.) Spokesman-Review about Congresswoman Lois Capps' request to postpone our review of Diablo Canyon's license renewal application. We told reporters that the Chairman will respond to her letter but right now, we are continuing with our review of all license applications.

2: ROBINSON – Greenwire contacted OPA with some questions on Thursday's end of cycle meeting at Robinson. The NRC announced at the meeting that the single-unit Progress Energy plant is in Column 3 of the Action Matrix and told the licensee that the agency expects improved safety performance this year.

3: VOGTLE FEIS – The NRC announced Friday it has issued the final Environmental Impact Statement for two proposed new reactors at the Vogtle site near Augusta, Ga. Region II OPA fielded questions from the Augusta Chronicle on the steps remaining for Southern Nuclear in its quest for a COL. Southern is on the record as saying it expects the new units to be licensed by the end of the year.

4: OCONEE -- The Greenville News called Region II OPA for some comments on plant safety in the wake of the events in Japan. The newspaper is publishing a Sunday story based on the Oconee tour Duke Energy conducted on Tuesday for Sen. Lindsey Graham, R-S.C., and more than 20 media representatives.

5: SEISMIC/JAPAN ISSUES – The Daily Local News (of West Chester, Pa.) hit us with an assortment of questions on our seismic risk study and Japan reactor event-related reviews. The reporter's interest was focused at least in part on the Limerick plant because of its proximity to the paper's coverage area. Separately, a reporter for CNN wanted to know why the Riverkeeper organization was asserting Indian Point was the plant with the greatest seismic vulnerability nationwide.

6: INDIAN POINT – The New York Daily News continues to ask us about exemptions granted to the plant over the years. This interest was sparked by New York State Assemblyman Richard Brodsky's repeated assertions that we granted exemptions to the plant in a reckless manner and without sufficient review. Bloomberg News Service continues to pose questions about the emergency plans for the plant. The Journal News (of Westchester, N.Y.) wanted to know if spent fuel pools will be part of our quick-look

CH/408

review. We said that they would be.

7: OYSTER CREEK – A reporter for the Chicago Tribune had a laundry list of new questions about our approval of the Oyster Creek license renewal application in 2009. They included how underground piping was assessed during the review and the ability of the public to participate in the process. The reporter said the concerns were being raised by the NIRS/Beyond Nuclear organization.

8: VERMONT YANKEE – The Commons newspaper is writing a follow-up to the renewed license and events in Japan.

9: SEABROOK – The Boston Globe will be running an editorial over the weekend criticizing the agency for allowing Seabrook to apply for a renewed license only half-way through its current license.

10: SPENT FUEL STORAGE -- The Connecticut Post is putting the finishing touches on a package of stories about spent fuel storage in the Northeast. Based on the questions being asked, it appears it will focus on the “dangers” of storing fuel in pools and the “benefit” of storing in a dry cask storage system.

11: LIMERICK -- The (Doylestown, Pa.) Intelligencer is working on a story on the earthquake and license renewal for Limerick. He asked questions about the EPA, seismic studies and license renewal process.

12: CALVERT CLIFFS -- There was a media day today, which normally attracts only the local reporters from the weekly and bi-weekly newspapers. Today, two TV stations (4 and 9) out of Washington showed up, as did WTOP-FM. Several print reporters were also in attendance.

13: PILGRIM -- A reporter from WHDH-TV in Boston figured out there was a nuclear plant nearby and needed help learning to navigate our web-page and understanding how reactors work.

14: SPENT FUEL POOLS AND PLANT SECURITY – A reporter for the Huffington Post called with several questions relating to power plant security and spent fuel pools. He was specifically interested in industry’s insistence that it needed extensions to implement our new security regulations as well as mitigative measures ordered by NRC for pools.

15: RADIATION MONITORING – An Associated Press reporter from San Francisco was playing catchup with the LA Times article about EPA’s RadNet monitors being out of service. She seemed to think NRC relied on those monitors and that the US population was unprotected as a result. We tried to explain rad monitoring at the plants and how licensees and local authorities would deploy field teams to monitor any radiation releases during a power plant event.

PRESS RELEASE ISSUED

NRC Issues Final Supplemental Environmental Impact Statement for Vogtle New Reactors Application

~~Internal use only – no distribution outside NRC – no redistribution internally~~

May contain material proprietary to news agencies

From: Sheron, Brian
To: Flory, Shirley
Subject: Electronic Certifications are done
Date: Friday, March 25, 2011 5:37:00 PM

CH/409

From: [Gibson, Kathy](#)
To: [Sheron, Brian](#)
Subject: DSA deputy notifications
Date: Friday, March 25, 2011 5:37:19 PM
Attachments: [Kathy Halvey Gibson.vcf](#)

Tom and I completed all notifications except for Mike Scott. I anticipate I will be in contact with him shortly when he wakes up and checks his messages.

I won't be in on Monday (Chris Hoxie is acting), so I anticipate you will make the announcement at the 8:45. I plan to send an email to the division at 10 am (provided I make contact with Mike).

Is this ok?

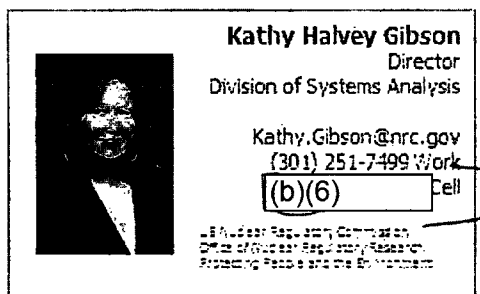

CH/410

Attachment Kathy Halvey Gibson_1.vcf (5196 Bytes) cannot be converted to PDF format.

From: Flory, Shirley
To: Sheron, Brian
Subject: THANKS!! RE: Electronic Certifications are done
Date: Friday, March 25, 2011 5:38:26 PM

From: Sheron, Brian
Sent: Friday, March 25, 2011 5:38 PM
To: Flory, Shirley
Subject: Electronic Certifications are done

CH/411

From: [Sheron, Brian](#)
To: [Kammerer, Annie](#)
Cc: [Case, Michael](#); [Richards, Stuart](#); [Hogan, Rosemary](#); [Uhle, Jennifer](#)
Subject: RE: Question
Date: Friday, March 25, 2011 5:56:00 PM

I think what you told me is that we can calculate the open ocean wave height very well. It is when it runs up on the shore, you need to know the near shore topography in detail in order to accurately calculate the runup wave height? If we know the near shore topography, are the models valid?

From: Kammerer, Annie
Sent: Friday, March 25, 2011 5:33 PM
To: Sheron, Brian
Cc: Case, Michael; Richards, Stuart; Hogan, Rosemary; Uhle, Jennifer
Subject: RE: Question

Hi Brian,

Sorry for the delay in getting back to you.

First let me clarify. NOAA's real time prediction of a tsunami wave have nothing to do with TEPCO's design basis tsunami. In terms of the real time wave, NOAA hasn't under predicted anything (8m offshore and 14m runup onshore are consistent quantities).

The best estimate of the wave at daiichi from NOAA was a 8 meters offshore (at the 5 meter bathymetric line—where the water at mean tide is 15 meters deep). This is a calculation performed using what is widely believed to be the best available global model for tsunami. So, that wasn't either a educated guess or professional judgment, it was a calculation using a well validated modeling tool. However, the numbers do have uncertainly based on the fact that the model does not have the preferred very high resolution bathymetric information in the very near shore area (that's why NOAA's calculations can push only to the 5meter bathy line). The NOAA model results were also informed by (and checked against) the recordings on the closest DART buoys, these are actual measurements of wave height and the pressure front in the open ocean.

A tsunami has two phases of response. In the open ocean it is very well behaved and calculations are highly accurate. As it gets close to shore and the shoaling effect begins, the behavior starts to go non-linear and very high resolution bathymetric (an topographic) information is required for a very precise prediction of runup (onto land) at any particular point on the coastline. However, it is well understood that as a tsunami wave comes onshore it grows in size significantly. Therefore, NOAA's calculation of 8 meters offshore and TEPCO's (most recently) announcement of 14 meters onshore are consistent.

My previous comment (before this event) was actually that NOAA's tsunami warning system models (NOAA, not the USGS) have been extremely well validated over time (with hundreds of real tsunami), and that continues to be the case. But, again, that is up to water depth where they have the necessary resolution of bathymetric data (and where the non-linear response begins in earnest). As a result of this fact, there is an effort currently to collect very high resolution data for the entire US pacific coast and to implement it into the NOAA database (currently the resolution of US data is not uniform). This will make US Pacific coast onshore runup predictions highly accurate. As part of the recent UW/NOAA contract, NOAA will give us a tool (ComMIT) that will provide NRC staff with very accurate run-up predictions in the areas around SONGS and Diablo during future tsunami warnings (it will allow us to do independent PTHA at SONGS and Diablo). We had recently pushed that technology transfer back to slow the burn rate on the UW/NOAA contract (due to budget cuts) but we may find that we need to find the money sooner rather than later so that we can run some analyses.

As noted, TEPCO has recently said the tsunami had a 14meters runup (onshore). However this is the 3rd time they have provided numbers. I didn't believe (and didn't post) their initial 2 postings because

CH/412

they were lower than NOAA's offshore measurements and calculations (which is inconsistent with basic physics). Also, we knew that it had to at least exceed the elevation of the equipment that was impacted. TEPCO is most likely (in my opinion) getting the measurements from watermarks on the buildings, or something similar. It's hard for me to believe that their tide gauges survived the tsunami, but one of NOAA's top experts in tide gauges and offshore measurements is my brother Carl (who, ironically was named after the Carl Kammerer who used to work at the NRC, who was my father's cousin). I can ask him about the chance of survival of equipment at the site. There are a lot of uncertainties with this, obviously, but 14 meters onshore is believable.

With regard to TEPCO's design basis tsunami, I have long gone on record as saying that the Japanese should be using PTHA, which would have predicted this water level, instead of the deterministic method that they use. Many of the tsunami specialists in Japan agree, and JNES had come around to that way of thinking due to their new concept of "residual risk". I think everyone was eagerly awaiting the new JSCE codes that detailed the PTHA technique to be used in Japan. Also, FYI, developing guidance on PTHA was identified as the #1 priority for the tsunami working group of the IAEA ISSC and NRC, JNES, and NOAA were going to jointly lead the work. We were supposed to have a kick of conference call to start the work the week after the earthquake hit. As we all know, fate intervened.

I hope this answers your questions.

Cheers,
Annie

From: Sheron, Brian
Sent: Thursday, March 24, 2011 8:27 AM
To: Kammerer, Annie
Cc: Case, Michael; Richards, Stuart; Hogan, Rosemary; Uhle, Jennifer
Subject: Question

I am seeing a spectrum of tsunami wave heights that reportedly hit the Fukushima plant. I saw in one of your briefing packages that was a USGS calculation that showed the peak wave height at about 30 feet. I saw some slides from TEPCO yesterday that said the tsunami wave height at the plant was "more than 10 meters". In today's "Nucleonics Week" on page 11 it says "Tepco discovered by checking the walls of Fukushima 1and the nearby Fukushima 2March 21 that the tsunamis had reached higher than 14 meters (about 46 feet) above sea level...." It then said the design basis for Fukushima 1 &2 was 5.7 and 5.2 meters respectively.

Without any accurate measurements, are we limited to educated guesses and expert judgment?

I think one question we will be asked is how well can we predict a tsunami wave height? I seem to recall you said the USGS calculations (wave height versus time at various locations) were probably pretty good because they had a well validated model. However, it would now appear they significantly under-predicted the wave height.

Am I missing something?

From: Sheron, Brian
To: Richards, Stuart
Cc: Gibson, Kathy; Case, Michael; Schaperow, Jason
Subject: RE: NUREG/CR-6920
Date: Friday, March 25, 2011 5:59:00 PM

Do we still agree with the probability numbers in your third bullet based on what we learned from SOARCA?

From: Richards, Stuart
Sent: Friday, March 25, 2011 5:54 PM
To: Sheron, Brian
Cc: Gibson, Kathy; Case, Michael
Subject: NUREG/CR-6920

Brian

A quick look at NUREG/CR-6920 indicates the following preliminary information:

- The purpose of 6920 was to look at the impact of assumed degradation of the containment on the probability of containment failure. For instance, 6920 assumed cases of 25% or 50% corrosion of various locations within the containment as part of the study. The study looked at both PWRs and BWRs.
- 6920 used information from NUREG-1150 as a starting point.
- NUREG-1150 estimates about a 56% probability of early containment failure at Peach Bottom (Mark I containment) from all scenarios, and about a 36% probability from a direct melt-through of the containment once the core has breached the RPV. These numbers are relatively consistent with the 6920 numbers. 6920 concluded that the corrosion scenarios don't impact the numbers much because the probability is so dominated by the core melt through scenario.
- NUREG-1150 lists station blackout as the dominant risk.

Note that the probability of a melt-through of containment assumes a breach of the RPV. I think it also assumes a fairly quick accident progression, so the fact that the Japanese event started two weeks ago may impact the probability of containment failure.

We can provide more info on Monday.

Stu

CH/413

From: Richards, Stuart
To: Sheron, Brian
Cc: Gibson, Kathy; Case, Michael; Hogan, Rosemary; Graves, Herman
Subject: RE: NUREG/CR-6920
Date: Friday, March 25, 2011 6:02:34 PM

Brian

We'll work with DSA on Monday.

Stu

From: Gibson, Kathy
Sent: Friday, March 25, 2011 6:01 PM
To: Sheron, Brian; Richards, Stuart
Cc: Case, Michael; Schaperow, Jason; Tinkler, Charles
Subject: RE: NUREG/CR-6920

I asked Jason and Charlie to get with DE next week and let us know.

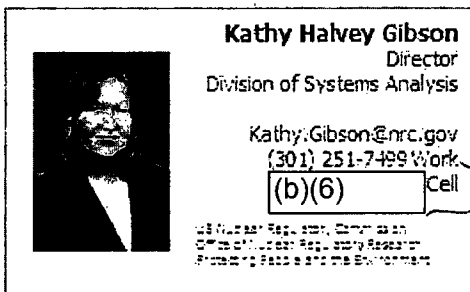

From: Sheron, Brian
Sent: Friday, March 25, 2011 6:00 PM
To: Richards, Stuart
Cc: Gibson, Kathy; Case, Michael; Schaperow, Jason
Subject: RE: NUREG/CR-6920

Do we still agree with the probability numbers in your third bullet based on what we learned from SOARCA?

From: Richards, Stuart
Sent: Friday, March 25, 2011 5:54 PM
To: Sheron, Brian
Cc: Gibson, Kathy; Case, Michael
Subject: NUREG/CR-6920

Brian

A quick look at NUREG/CR-6920 indicates the following preliminary information:

- The purpose of 6920 was to look at the impact of assumed degradation of the containment on the probability of containment failure. For instance, 6920 assumed cases of 25% or 50% corrosion of various locations within the containment as part of the study.

CH/414

The study looked at both PWRs and BWRs.

- 6920 used information from NUREG-1150 as a starting point.

- NUREG-1150 estimates about a 56% probability of early containment failure at Peach Bottom (Mark I containment) from all scenarios, and about a 36% probability from a direct melt-through of the containment once the core has breached the RPV. These numbers are relatively consistent with the 6920 numbers. 6920 concluded that the corrosion scenarios don't impact the numbers much because the probability is so dominated by the core melt through scenario.

- NUREG-1150 lists station blackout as the dominant risk.

Note that the probability of a melt-through of containment assumes a breach of the RPV. I think it also assumes a fairly quick accident progression, so the fact that the Japanese event started two weeks ago may impact the probability of containment failure.

We can provide more info on Monday.

Stu

From: [LIA07 Hoc](#)
Subject: 1800 EDT (March 25, 2011) USNRC Earthquake/Tsunami Status Update
Date: Friday, March 25, 2011 6:50:42 PM
Attachments: [USNRC Earthquake-Tsunami Update 032511 1800EDT.pdf](#)

Attached, please find an 1800 EDT (March 25, 2011) status update from the US Nuclear Regulatory Commission's Emergency Operations Center regarding the impacts of the earthquake/tsunami.

Please note that this information is "Official Use Only" and is only being shared within the federal family.

Please call the Headquarters Operations Officer at 301-816-5100 with questions.

-Sara

Sara K. Mroz
Communications and Outreach
Office of Nuclear Security and Incident Response
US Nuclear Regulatory Commission
Sara.Mroz@nrc.gov
LIA07.HOC@nrc.gov (Operations Center)

CH/415

From: LIA07 Hoc
To: Borchardt, Bill; Bradford, Anna; Cohen, Shari; Cooper, LaToya; Dyer, Jim; Flory, Shirley; Gibbs, Catina; Haney, Catherine; Hudson, Sharon; Jaczko, Gregory; Johnson, Michael; Leeds, Eric; Loyd, Susan; Pace, Patti; Schwarz, Sherry; Sheron, Brian; Speiser, Herald; Sprogeris, Patricia; Taylor, Renee; Virgilio, Martin; Walls, Lorena; Weber, Michael
Subject: Revised Status Update
Date: Friday, March 25, 2011 7:13:23 PM
Attachments: USNRC Earthquake-Tsunami Update 032511 1800EDT(rev).pdf

Resending the 1800EDT Status Update (to remove the "Draft" watermark)

Sorry for any confusion.

-Sara

From: LIA07 Hoc
Sent: Friday, March 25, 2011 6:56 PM
To: Borchardt, Bill; Bradford, Anna; Cohen, Shari; Cooper, LaToya; Dyer, Jim; Flory, Shirley; Gibbs, Catina; Haney, Catherine; Hudson, Sharon; Jaczko, Gregory; Johnson, Michael; Leeds, Eric; Loyd, Susan; Pace, Patti; Schwarz, Sherry; Sheron, Brian; Speiser, Herald; Sprogeris, Patricia; Taylor, Renee; Virgilio, Martin; Walls, Lorena; Weber, Michael
Subject: Update for Go Books - 1800 EDT, March 25, 2011

Please find attached updated information for the "Go Books".

The updates include:

- The 1800 EDT, 03/25/11 Status Update
- The latest ET Chronology
- The latest TEPCO Press Releases (Numbers 152-162)
- NRC Talking Points (GI-199)
- "One Pager" (1500 EDT, 03/25/11)

Please let me know if you have any questions or concerns.

-Sara

Sara Mroz
Communications and Outreach
Office of Nuclear Security and Incident Response
US Nuclear Regulatory Commission
Sara.Mroz@nrc.gov
LIA07.HOC@nrc.gov (Operations Center)

CH/416

From: [LIA07 Hoc](#)
Subject: Resent: 1800 EDT (March 25, 2011) USNRC Earthquake/Tsunami Status Update
Date: Friday, March 25, 2011 7:08:39 PM
Attachments: [USNRC Earthquake-Tsunami Update 032511 1800EDT\(rev\).pdf](#)

Resent to remove the "Draft" watermark.

Attached, please find an 1800 EDT (March 25, 2011) status update from the US Nuclear Regulatory Commission's Emergency Operations Center regarding the impacts of the earthquake/tsunami.

Please note that this information is "Official Use Only" and is only being shared within the federal family.

Please call the Headquarters Operations Officer at 301-816-5100 with questions.

-Sara

Sara K. Mroz
Communications and Outreach
Office of Nuclear Security and Incident Response
US Nuclear Regulatory Commission
Sara.Mroz@nrc.gov
LIA07.HOC@nrc.gov (Operations Center)

CH/417

From: Johnson, Kevin
To: Sheron, Brian; Uhle, Jennifer; Sangimino, Donna-Marie; Donaldson, Leslie; Dempsey, Heather; Rini, Brett; Ramirez, Annie; Ibarra, Jose; Rivera-Lugo, Richard; Case, Michael; Richards, Stuart; Coe, Doug; Lam, Kim; Goldfeiz, Banu; Grancorvitz, Teresa; Kardaras, Tom; Valentin, Andrea; Parks, Jazel
Subject: Items of Importance for the Week of 4/1/11
Date: Friday, March 25, 2011 7:29:10 PM

DE - G20110146 – Draft Final Regulatory Guides 1.34, 1.43, 1.44, and 1.50
Due to EDO – 3/31/11 – Current Status – With Division

DE – WITS 200800100 – Status of the Regulatory Guide Update Program
Due to EDO – 4/1/11 – Current Status – With FO for review

DE – G20100585 – Groundwater Task Force Report – Dialogue on Groundwater Protection Through CSNI
Due to EDO – 4/1/11 – Current Status – With Division

PMDA – G20110151 – Update to the Enclosure of the 2010 Annual Report on IAEA/NEA
..
Due to OIP & OEDO – 3/28/11 – Current Status – With Division

RES – 20110156 – Update of the Information Digest
Due to Glenn Ellmers/OEDO – 3/28/11 – Current Status – With Division

All Divisions: FY 2011 2nd Quarter Performance Report (Op Plan)
Due to Kim and Sibel – 3/31/11

All Divisions – Please keep in mind the FOIA Requests that are due this and week and after.

Thanks

Kevin

One Team/One Goal

Kevin D. Johnson
Research Information Specialist
Office of Nuclear Regulatory Research
RES/PMDA/HCCB
Email: Kevin.Johnson@nrc.gov
O6AO6a
Office: 301-251-7665

CH/418

From: Johnson, Kevin
To: Gibson, Kathy; Beasley, Benjamin; Case, Michael; Coe, Doug; Coyne, Kevin; Csontos, Aladar; Demoss, Gary; Donaldson, Leslie; Gavrilas, Mirela; Gibson, Kathy; Hogan, Rosemary; Hoxie, Chris; Kardaras, Tom; Koshy, Thomas; Lee, Richard; Oklesson, Edward; Ott, William; Peters, Sean; Richards, Stuart; Rini, Brett; Salley, MarkHenry; Santiago, Patricia; Sheron, Brian; Srinivasan, Makuteswara; Sydnor, Russell; Sangimino, Donna-Marie; Uhle, Jennifer; Cupidon, Les; Zabel, Joseph; Dempsey, Heather; DO, HA; Dion, Jeanne; Ibarra, Jose; Rivera-Lugo, Richard; Ramirez, Annie; Kardaras, Tom; Valentin, Andrea
Subject: ATMIS REPORT - 3/25/2011
Date: Friday, March 25, 2011 7:48:38 PM
Attachments: rptCombinedReportByDivision.pdf

ATTACHED

ATMIS REPORT – 3/25/2011

KEVIN

One Team/One Goal

Kevin D. Johnson
Research Information Specialist
Office of Nuclear Regulatory Research
RES/PMDA/HCCB
Email: Kevin.Johnson@nrc.gov
O6A06a
Office: 301-251-7665

CH/419

Action Items for Division DE

Task Source	Roadmap	Reference	DIR/Branch	Task Description	Special Instructions	Current Status	Responsible
-------------	---------	-----------	------------	------------------	----------------------	----------------	-------------

RES #2010478	<input type="checkbox"/>	EDO #20110146	RES NONE	Draft Final Regulatory Guides 1.34, 1.43, 1.44, and 1.50 (EDATS.OEDO-2011-0170) (Due to FO)	Please prepare response to ACRS for the signature of the EDO. Add the Commission and SECY as cc's. Also, include: RidsAcrsAcnw_MaiCTR to your distribution on the concurrence page. USE SUBJECT LINE IN RESPONSE.		Michael Case
--------------	--------------------------	---------------	----------	---	---	--	--------------

Milestone Description	Original Dat	Revised Date
Due to FO	3/28/2011	
Briefing/FO	3/29/2011	
Due to EDO	3/31/2011	

RES #2010480	<input type="checkbox"/>		RES NONE	Senior Performance Official (SPO) Reports (Ticket 1) (Task 1)	Task 1: Divisions provide input to central SPO and RES self-assessment		Michael Case
--------------	--------------------------	--	----------	---	--	--	--------------

Milestone Description	Original Dat	Revised Date
Task 1	3/23/2011	3/28/2011

RES #2010501	<input type="checkbox"/>		RES NONE	ACRS Biennial Review and ROMA Update (Task 1)	T1, Enter the relevant technical area T2, Review the scope, T3, Review the current Need entry, Also, please review the attached email for detail instructions and milestones as it pertains to the action item.		Michael Case
--------------	--------------------------	--	----------	---	--	--	--------------

Milestone Description	Original Dat	Revised Date
Task 1	3/28/2011	
Task 3	3/28/2011	
Task 2	3/28/2011	

Action Items for Division DE

Task Source	Roadmap	Reference	DIR/Branch	Task Description	Special Instructions	Current Status	Responsible
RES #2010509	<input type="checkbox"/>		RES NONE	MD and Handbook 3.7, "NUREG-SERIES PUBLICATIONS" AND MD and Handbook 3.11, "CONFERENCES AND CONFERENCE PROCEEDINGS" (Due to Joe Zabel)	Please review the Management Directives and provide comments if any to Joe Zabel by March 25, 2011.		Michael Case
				Milestone Description	Original Dat	Revised Date	
				Due to Joe Zabel	3/25/2011	3/28/2011	
RES #2008053	<input type="checkbox"/>	WITS #200800100	DE NONE	Provide the Commission with an annual summary of progress in the Reg. Guide Update Program [EDATS: SECY-2008-0059/ EDATS: RES-2009-0054] (EDATS:SECY-2010-0180) (Due to FO)			M. Case
				Milestone Description	Original Dat	Revised Date	
				Due to FO	3/29/2011		
				Briefing/FO	3/30/2011		
				Due to EDO/SECY	4/1/2011		
RES #2010240	<input type="checkbox"/>	EDO #20100585	RES NONE	Groundwater Task Force Report - Dialogue on Groundwater Protection Through CSNI (EDATS:OEDO-2010-0765) (Due to FO)	Please review the green ticket for more detailed instructions pertaining to the action item.		Mike Case
				Milestone Description	Original Dat	Revised Date	
				Due to FO	3/29/2011		
				Briefing/FO	3/30/2011		
				Due to EDO	4/1/2011		
RES #2010497	<input type="checkbox"/>		RES NONE	OEDO Procedure 510 and OEDO Procedure 520 (Due to Brett Rini)	Please review and provide comments if any to Brett Rini by March 29, 2011.		Michael Case
				Milestone Description	Original Dat	Revised Date	
				Due to Brett Rini	3/29/2011		
RES #2010470	<input type="checkbox"/>		RES NONE	FY 2011 2nd Quarter Performance Report (Op Plan) (EDATS:RES-2011-0018) (Due to K. Lam & S. Goldfeiz)	Please review the attached email for detail instructions pertaining to the action item.		Michael Case
				Milestone Description	Original Dat	Revised Date	
				Due to K. Lam & S. Goldfeiz	4/4/2011	3/31/2011	

Action Items for Division DE

Task Source Roadmap Reference	DIR/Branch	Task Description	Special Instructions	Current Status	Responsible
RES #2010406 <input type="checkbox"/>	RES NONE	Revising OI-PRM-001: Process for New Work Requests (EDATS:RES-2011-0011) (Division concurrence)	Provide division concurrence on final version of OI-PRM-001		Michael Case
		Milestone Description	Original Dat	Revised Date	
		Division concurrence	3/16/2011	4/4/2011	
RES #2010149 <input type="checkbox"/>	RES NONE	National Lab Visits (May - August)	Please identify all lab visits every 4 months and provide an update to Pat Santiago on the following dates: September 3, 2010, December 10, 2010 and April 8, 2011.		Michael Case
		Milestone Description	Original Dat	Revised Date	
		May - August	4/8/2011		
RES #2010489 <input type="checkbox"/>	RES NONE	User Need Request for Diablo Canyon Power Plant Shoreline Fault Review (NRR-2011-003) (Update the FO)			Michael Case/Annie Kammerer
		Milestone Description	Original Dat	Revised Date	
		Update the FO	4/8/2011		
RES #2010095 <input type="checkbox"/>	RES NONE	Propose article for Researcher (Due to PMDA/FO)	Please prepare a draft technical article from your division for Amy Bonaccorso and cc RES TA.		Michael Case
		Milestone Description	Original Dat	Revised Date	
		Due to PMDA/FO	4/15/2011		
RES #2010211 <input type="checkbox"/>	RES NONE	Provide input on MIT Summer Safety Course (Due to Brett Rini)	See incoming		Mike Case
		Milestone Description	Original Dat	Revised Date	
		Due to Brett Rini	4/15/2011		
RES #2010405 <input type="checkbox"/>	EDO #20110012	RES NONE	IAEA Draft Safety Guide "External Expert Support on Safety Issues" (DS-429) (Due to IAEA: 4/30/11) (EDATS:OEDO-2011-0013) (Due to EDO)	Coordinate with other NRC offices, as appropriate, the review and comments on IAEA Draft Safety Guide (ML110100055).	Michael Case
		Milestone Description	Original Dat	Revised Date	
		Due to EDO	4/15/2011		
		Due to IAEA	4/30/2011		

Action Items for Division DE

Task Source	Roadmap	Reference	DIR/Branch	Task Description	Special Instructions	Current Status	Responsible
RES #2010524	<input type="checkbox"/>		RES NONE	Proposed construction of a nuclear plant in Payette County Idaho (Update the RES Mailroom)			Michael Case
				Milestone Description	Original Dat	Revised Date	
				Update the RES Mailroom	4/22/2011		
RES #2010537	<input type="checkbox"/>		RES NONE	Draft User Need Request - Extended Storage and Transportation Regulatory Program Review (NMSS-2011-002) (Update the FO)			Michael Case
				Milestone Description	Original Dat	Revised Date	
				Update the FO	4/25/2011		
RES #2010447	<input type="checkbox"/>	EDO #20110094	RES NONE	IAEA Draft Safety Guide "Criticality Safety for Facilities and Activities Handling Fissionable Material" (DS407) (EDATS:OEDO-2011-0106) (Update the FO)	Please review the green ticket attachment for more detail instructions pertaining to the action.		Michael Case
				Milestone Description	Original Dat	Revised Date	
				Update the FO	4/27/2011		
				Due to EDO	4/29/2011		
RES #2010515	<input type="checkbox"/>		RES NONE	Revision of Designation Guide for Safeguards Information (DG-SGI-1) (Due to ISB)	Please review and provide comments if any to the ISB no later than April 29, 2011.		Michael Case/Rosemary Hogan
				Milestone Description	Original Dat	Revised Date	
				Due to ISB	4/29/2011		
RES #2010512	<input type="checkbox"/>		RES NONE	GG Mid-year Reviews (Due to Debbie Chan)	Division Directors certify via email that GG mid-year performance reviews, discussions, and ratings are completed by 5/6/11.		Michael Case
				Milestone Description	Original Dat	Revised Date	
				Due to Debbie Chan	5/6/2011		

Action Items for Division DRA

Task Source Roadmap Reference	DIR/Branch	Task Description	Special Instructions	Current Status	Responsible
-------------------------------	------------	------------------	----------------------	----------------	-------------

RES #2010503		RES NONE	ACRS Biennial Review and ROMA Update (Task 3)	T1, Enter the relevant technical area T2, Review the scope, T3, Review the current Need entry. Also, please review the attached email for detail instructions and milestones as it pertains to the action item.	Doug Coe
--------------	--	----------	---	--	----------

Milestone Description	Original Dat	Revised Date
Task 3	3/28/2011	
Task 1	3/28/2011	
Task 2	3/28/2011	
Task 4	3/30/2011	
Task 5	4/1/2011	
Task 6	4/15/2011	

RES #2010499		RES NONE	OEDO Procedure 510 and OEDO Procedure 520 (Due to Brett Rini)	Please review and provide comments if any to Brett Rini by March 29, 2011.	Doug Coe
--------------	--	----------	---	--	----------

Milestone Description	Original Dat	Revised Date
Due to Brett Rini	3/29/2011	

RES #2010471		RES NONE	FY 2011 2nd Quarter Performance Report (Op Plan) (EDATS:RES-2011-0018) (Due to K. Lam & S. Goldfeiz)	Please review the attached email for detail instructions pertaining to the action item.	Doug Coe
--------------	--	----------	--	---	----------

Milestone Description	Original Dat	Revised Date
Due to K. Lam & S. Goldfeiz	4/4/2011	3/31/2011

RES #2003097	WITS #200300066	NONE OEGIB	Semiannual Report to Congress (EDATS:2010-0324) (Update the FO/Brett Rini)	Waiting for DRA to send EDO closeout info. before closoing in ATMS	Doug Coe/B. Beasley
--------------	-----------------	------------	--	--	---------------------

Milestone Description	Original Dat	Revised Date
Update the FO/Brett Rini	4/4/2011	
Due to OEDO/Roger Rihm	4/6/2011	

Action Items for Division DRA

Task Source	Roadmap Reference	DIR/Branch	Task Description	Special Instructions	Current Status	Responsible
RES #2010408	<input type="checkbox"/>	RES NONE	Revising OI-PRM-001: Process for New Work Requests (EDATS:RES-2011-0011) (Division concurrence)	Provide division concurrence on final version of OI-PRM-001		Doug Coc
			Milestone Description	Original Dat	Revised Date	
			Division concurrence	3/16/2011	4/4/2011	
RES #2010151	<input type="checkbox"/>	RES NONE	National Lab Visits (May - August)	Please identify all lab visits every 4 months and provide an update to Pat Santiago on the following dates: September 3, 2010, December 10, 2010 and April 8, 2011.		Doug Coc
			Milestone Description	Original Dat	Revised Date	
			May - August	4/8/2011		
RES #2010212	<input type="checkbox"/>	RES NONE	Provide input on MIT Summer Safety Course (Due to Brett Rini)	Sec incoming		Doug Coc
			Milestone Description	Original Dat	Revised Date	
			Due to Brett Rini	4/15/2011		
RES #2010514	<input type="checkbox"/>	RES NONE	GG Mid-year Reviews (Due to Debbie Chan)	Division Directors certify via email that GG mid-year performance reviews, discussions, and ratings are completed by 5/6/11.		Doug Coc
			Milestone Description	Original Dat	Revised Date	
			Due to Debbie Chan	5/6/2011		

Action Items for Division DSA

Task Source	Roadmap Reference	DIR/Branch	Task Description	Special Instructions	Current Status	Responsible
RES #2010366	<input type="checkbox"/>	RES NONE	Office Instruction Bi-Annual Update (PRM-010), (TEC-003) (Due to Jazel Parks)	Please confirm if the OI is current, if it is not please confirm a date when the OI draft will be sent to Jazel Parks for review.		Kathy Gibson/Kenneth Armstrong
			Milestone Description	Original Dat	Revised Date	
			Due to Jazel Parks	3/28/2011		
RES #2010369	<input type="checkbox"/>	RES NONE	Office Instruction Bi-Annual Update (COM-010), (ADM-007) (Due to Jazel Parks)	Please confirm if the OI is current, if it is not please confirm a date when the OI draft will be sent to Jazel Parks for review.		Pat Santiago
			Milestone Description	Original Dat	Revised Date	
			Due to Jazel Parks	3/28/2011		
RES #2010466	<input type="checkbox"/>	RES NONE	Long-Term Research Program - LTRP Budget (EDATS:RES-2011-0016) (Update Sergio Gonzalez)	Please edit the attached spreadsheet on the G/DIROFF/Technical Assistan/LTRP Budget by March 18 and notify Sergio Gonzalez, RidsResPmdaMailResource and cc Ruth Spence and Kathleen Stout in PMDA.		Kathy Gibson
			Milestone Description	Original Dat	Revised Date	
			Update Sergio Gonzalez	3/18/2011	3/28/2011	
RES #2010502	<input type="checkbox"/>	RES NONE	ACRS Biennial Review and ROMA Update (Task 1)	T1, Enter the relevant technical area T2, Review the scope, T3, Review the current Need entry, Also, please review the attached email for detail instructions and milestones as it pertains to the action item.		Kathy Gibson
			Milestone Description	Original Dat	Revised Date	
			Task 1	3/28/2011		
			Task 3	3/28/2011		
			Task 2	3/28/2011		

Action Items for Division DSA

Task Source	Roadmap Reference	DIR/Branch	Task Description	Special Instructions	Current Status	Responsible
RES #2010498	<input type="checkbox"/>	RES NONE	OEDO Procedure 510 and OEDO Procedure 520 (Due to Brett Rini)	Please review and provide comments if any to Brett Rini by March 29, 2011.		Kathy Gibson
			Milestone Description	Original Dat	Revised Date	
			Due to Brett Rini	3/29/2011		
RES #2010472	<input type="checkbox"/>	RES NONE	FY 2011 2nd Quarter Performance Report (Op Plan) (EDATS:RES-2011-0018) (Due to K. Lam & S. Goldfeiz)	Please review the attached email for detail instructions pertaining to the action item.		Kathy Gibson
			Milestone Description	Original Dat	Revised Date	
			Due to K. Lam & S. Goldfeiz	4/4/2011	3/31/2011	
RES #2010407	<input type="checkbox"/>	RES NONE	Revising OI-PRM-001: Process for New Work Requests (EDATS:RES-2011-0011) (Division concurrence)	Provide division concurrence on final version of OI-PRM-001		Kathy Gibson
			Milestone Description	Original Dat	Revised Date	
			Division concurrence	3/16/2011	4/4/2011	
RES #2010525	<input type="checkbox"/>	RES NONE	Prepare response to (User Need : NMSS-2011-001): "Request for Research to Continue Assisting NMSS to Review CFD Methods Applied to Storage Casks Design" (Due to FO)			Kathy Gibson
			Milestone Description	Original Dat	Revised Date	
			Due to FO	4/13/2011		
			Due to NMSS	4/15/2011		
RES #2010213	<input type="checkbox"/>	RES NONE	Provide input on MIT Summer Safety Course (Due to Brett Rini)	See incoming		Kathy Gibson
			Milestone Description	Original Dat	Revised Date	
			Due to Brett Rini	4/15/2011		
RES #2010485	<input type="checkbox"/>	RES NONE	OECD/NEA - STEM Project for Statement of Interest by Countries (Due to Jean Gauvain)	Please review and provide comments to Jean Gauvain by May 5, 2011.		Kathy Gibson
			Milestone Description	Original Dat	Revised Date	
			Due to Jean Gauvain	5/5/2011		

Action Items for Division DSA

Task Source	Roadmap	Reference	DIR/Branch	Task Description	Special Instructions	Current Status	Responsible
RES #2010455	<input type="checkbox"/>	FOIA #2011-0083	RES SPB	SOARCA (Due to OIS)	Please provide all information requested within this FOIA to Jazel Parks by 2/21/2011		Kathy Gibson/Kenneth Armstrong

Milestone Description	Original Date	Revised Date
-----------------------	---------------	--------------

Due to OIS	2/22/2011	5/6/2011
Due to J. Parks	2/21/2011	5/6/2011

RES #2010513	<input type="checkbox"/>		RES NONE	GG Mid-year Reviews (Due to Debbie Chan)	Division Directors certify via email that GG mid-year performance reviews, discussions, and ratings are completed by 5/6/11.		Kathy Gibson
--------------	--------------------------	--	----------	--	--	--	--------------

Milestone Description	Original Date	Revised Date
-----------------------	---------------	--------------

Due to Debbie Chan	5/6/2011	
--------------------	----------	--

Action Items for Division PMDA

Task Source	Roadmap Reference	DIR/Branch	Task Description	Special Instructions	Current Status	Responsible
RES #2010479	<input type="checkbox"/> EDO #20110151	RES NONE	Update to the Enclosure of the 2010 Annual Report on IAEA/NEA Activity Descriptions and Associated Draft Communication Paper (EDATS:OEDO-2011-0175) (Due to OIP & OEDO)	Please provide input to Jennifer Schwartzman, OIP with cc: to Shawn Williams, OEDO and RidsEdoMailCenter, RidsResPmdaMailResource by March 28, 2011.		Antony Calvo/Jeff Dehn
			Milestone Description	Original Dat	Revised Date	
			Due to OIP & OEDO	3/28/2011		
RES #2010486	<input type="checkbox"/>	RES NONE	MD and Handbook 3.7, "NUREG-SERIES PUBLICATIONS" AND MD and Handbook 3.11, "CONFERENCES AND CONFERENCE PROCEEDINGS" (Input from Divisions)			Leslie Donaldson/Joc Zabel
			Milestone Description	Original Dat	Revised Date	
			Input from Divisions	3/25/2011	3/28/2011	
			Due to B. Martin & K.A. Kribs	3/30/2011		
RES #2010505	<input type="checkbox"/>	RES NONE	ACRS Biennial Review and ROMA Update (Task 1)	Please review the attached email for detail instructions and milestones as it pertains to the action item.		Teresa Grancorvitz
			Milestone Description	Original Dat	Revised Date	
			Task 1	3/28/2011		
			Task 2	3/28/2011		
			Task 3	3/28/2011		
			Task 4	3/30/2011		
			Task 5	4/1/2011		
			Task 6	4/15/2011		
RES #2010473	<input type="checkbox"/>	RES NONE	FY 2011 2nd Quarter Performance Report (Op Plan) (EDATS:RES-2011-0018) (Due to K. Lam & S. Goldfeiz)	Please review the attached email for detail instructions pertaining to the action item.		PMDA BCs and TLs
			Milestone Description	Original Dat	Revised Date	
			Due to K. Lam & S. Goldfeiz	4/4/2011	3/31/2011	

Action Items for Division PMDA

Task Source Roadmap Reference	DIR/Branch	Task Description	Special Instructions	Current Status	Responsible
RES #2010474 <input type="checkbox"/>	RES NONE	FY 2011 2nd Quarter Performance Report (Op Plan) (EDATS:RES-2011-0018) (Due to Kim Lam & S. Goldfeiz)	Please review the attached email for detail instructions pertaining to the action item.		Antony Calvo/Wendy Eisenberg

Milestone Description	Original Dat	Revised Date
Due to Kim Lam & S. Goldfeiz	4/4/2011	3/31/2011

RES #2010493 <input type="checkbox"/>	RES NONE	Continuation of Agency Virtual Meeting Services (Due to Tammy Trocki, OIS)	Please return the enclosed Memorandum of Understanding (MOU) and a completed Request for Procurement Action by April 1, 2011.		Leslie Donaldson
---------------------------------------	----------	--	---	--	------------------

Milestone Description	Original Dat	Revised Date
Due to Tammy Trocki, OIS	4/1/2011	

RES #2010520 <input type="checkbox"/>	RES NONE	Fiscal Year 2011 Funds Utilization Plan and Third Quarter Advance Procurement Plan (Due to OCFO/DPB/ADM)	Third Quarter FUP submission due to OCFO/DPB on 4/5/11. Update - The APP date is extended to April 1st and the FUP date has been extended to April 8th.		Teresa Grancorvitz
---------------------------------------	----------	--	---	--	--------------------

Milestone Description	Original Dat	Revised Date
Due to OCFO/DPB/ADM	4/1/2011	
Due to OCFO/DPB/ADM	4/8/2011	

RES #2010410 <input type="checkbox"/>	RES NONE	Revising OI-PRM-001: Process for New Work Requests (EDATS:RES-2011-0011) (Task 2)	Task 1: Obtain division comments on OI-PRM-001 from J. Dion Task 2: Prepare final OI for FO review, Task 3: Process approved OI		Tom Kardaras/Jazel Parks
---------------------------------------	----------	---	--	--	--------------------------

Milestone Description	Original Dat	Revised Date
Task 2	2/11/2011	4/4/2011
Task 3	4/14/2011	

Action Items for Division PMDA

Task Source	Roadmap Reference	DIR/Branch	Task Description	Special Instructions	Current Status	Responsible
RES #2010494	<input type="checkbox"/>	RES NONE	SES Mid-year Appraisals (Task 1)	T1, Wording for D/DD, T2, B. Rini completes draft wording, T3, Input to support mid-year review, T4, Mid-year discussions completed, T5, Completed SES Performance Plans, T6, copy of each SES Performance Plan/J. Gallagher		Leslie Donaldson/Debbie Chan

Milestone Description	Original Dat	Revised Date
Task 1	4/4/2011	
Task 2	4/11/2011	
Task 3	4/15/2011	

RES #2010507	<input type="checkbox"/>	RES NONE	Nuclear Energy Agency Steering Committee for Nuclear Energy Meeting 28th - 29th of April 2011 (Background Information Requested) (Input from DSA)	Please review and provide your input to Charles Miller with a copy to Dr. Donald A. Cool by April 7, 2011.		Donna-Maric-Sangimino
--------------	--------------------------	----------	---	--	--	-----------------------

Milestone Description	Original Dat	Revised Date
Input from DSA	4/5/2011	
Due to FSME	4/7/2011	

RES #2010521	<input type="checkbox"/>	RES NONE	Computer Matching Programs (Due to Sandra Northern, OIS)	Send your response by e-mail to Sandra Northern, no later than April 8, 2011.		Tom Kardaras
--------------	--------------------------	----------	--	---	--	--------------

Milestone Description	Original Dat	Revised Date
Due to Sandra Northern, OIS	4/8/2011	

RES #2010536	<input type="checkbox"/>	RES NONE	External Awards/Recognition (Due to Anthony Barnes/SBCR)	Please provide a list of those employees from your office that have received external awards/recognition during FY 2010-2011 for NRC mission related professional achievements.		Leslie Donaldson/Ed Oklesson
--------------	--------------------------	----------	--	---	--	------------------------------

Milestone Description	Original Dat	Revised Date
Due to Anthony Barnes/SBCR	4/13/2011	

RES #2010425	<input type="checkbox"/>	RES NONE	Second Quarter Performance Report (Due to Mike Weber, OEDO)			Teresa Grancorvitz
--------------	--------------------------	----------	---	--	--	--------------------

Milestone Description	Original Dat	Revised Date
-----------------------	--------------	--------------

Action Items for Division PMDA

Task Source	Roadmap Reference	DIR/Branch	Task Description	Special Instructions	Current Status	Responsible
RES #2010492	<input type="checkbox"/>	RES NONE	Due to Mike Weber, OEDO SORRTG Questionnaire and CSNI Position Paper (Due to Greg Lamarre)	4/15/2011 Please review and provide comments if any to Greg Lamarre by April 15, 2011.		Antony Calvo
			Milestone Description	Original Dat	Revised Date	
			Due to Greg Lamarre	4/15/2011		
RES #2010539	<input type="checkbox"/>	EDO #20110206 RES NONE	Solicitation of Information for DEDR Topics of Discussion for the 29th Meeting of the Commission on Safety Standards (CSS) in Vienna, Austria, May 25-27, 2011 (EDATS:OEDO-2011-0217) (Update the FO)	Please review the green ticket for detail instructions as it pertains to the action item.		Donna Marie-Sangimino
			Milestone Description	Original Dat	Revised Date	
			Update the FO	5/2/2011		
			Due to EDO	5/4/2011		
RES #2010496	<input type="checkbox"/>	RES NONE	GG Mid-year Reviews (Task 1)	T1, Division Directors certify via email that mid-year performance reviews, discussions, and ratings are completed. T2, Certification of completion of mid-year review is sent to HR via email.		Leslie Donaldson/Debbie Chan
			Milestone Description	Original Dat	Revised Date	
			Task 1	5/6/2011		

Action Items for Division RES

Task Source	Roadmap Reference	DIR/Branch	Task Description	Special Instructions	Current Status	Responsible
-------------	-------------------	------------	------------------	----------------------	----------------	-------------

RES #2010482		RES NONE	Senior Performance Official (SPO) Reports (Ticket 1) (Task 2)	T2, Mtg to discuss draft Mid-Year's SPOs, T3, RES assessment offices/regions, T4, Discussions brw offices, as needed, T5, RES self-assessment, T6, self-assessment/all office assessments, T7, OEDO/DEDOs/discussions, Op Plan w/OD's/RA's		Brett Rini
--------------	--	----------	---	--	--	------------

Milestone Description	Original Dat	Revised Date
-----------------------	--------------	--------------

Task 2	3/28/2011	
Task 3	4/1/2011	
Task 5	4/11/2011	
Task 4 - (04/04-04/14/11)	4/4/2011	4/11/2011
Task 6	4/15/2011	
Task 7	4/22/2011	
Op Plan with OD's/RA's	4/29/2011	

RES #2010487	EDO #20110156	RES NONE	Update of the Information Digest (EDATS:OEDO-2011-0181) (Due to Glenn Ellmers, OEDO)	Sec guidance attached. Please provide all material via email to Glenn Ellmers, OEDO and the RidsEdoMailCenter, RidsResPmdaMailResource by March 28, 2011.		Brett Rini
--------------	---------------	----------	--	---	--	------------

Milestone Description	Original Dat	Revised Date
-----------------------	--------------	--------------

Due to Glenn Ellmers, OEDO	3/28/2011	
----------------------------	-----------	--

RES #2010500		RES NONE	OEDO Procedure 510 and OEDO Procedure 520 (Input from Divisions)			Brett Rini
--------------	--	----------	--	--	--	------------

Milestone Description	Original Dat	Revised Date
-----------------------	--------------	--------------

Input from Divisions	3/29/2011	
Due to Kathy Clayton, OEDO	3/31/2011	

Action Items for Division RES

Task Source	Roadmap Reference	DIR/Branch	Task Description	Special Instructions	Current Status	Responsible
RES #2010504	<input type="checkbox"/>	RES NONE	ACRS Biennial Review and ROMA Update (Task 4)	T4, Sort the final inputs T5, Send data on which projects/tech review, T6, Work with PMDA/User Need, Also, please review the attached email for detail instructions and milestones as it pertains to the action item.		Brett Rini

Milestone Description	Original Dat	Revised Date
Task 4	3/30/2011	
Task 5	4/1/2011	
Task 6	4/15/2011	

RES #2010516	<input type="checkbox"/>	FOIA #2010-0119	RES NONE	March 11 Earthquake (J. Parks)	Please provide all information as stated in the request to J. Parks COB March 30, 2011	Kenneth Armstrong
--------------	--------------------------	-----------------	----------	--------------------------------	--	-------------------

Milestone Description	Original Dat	Revised Date
J. Parks	3/30/2011	
OIS	3/31/2011	

RES #2010517	<input type="checkbox"/>	FOIA #2011-0119	DRA NONE	March 11th Earthquake (J. Parks)	Please provide all information as stated in the request to J. Parks COB March 30, 2011	Jose Ibarra
--------------	--------------------------	-----------------	----------	----------------------------------	--	-------------

Milestone Description	Original Dat	Revised Date
J. Parks	3/30/2011	
OIS	3/31/2011	

RES #2010518	<input type="checkbox"/>	FOIA #2011-0119	DE SGSEB	March 11th Earthquake (Due to J. Parks)	Please provide all information as stated in the request to J. Parks by COB March 30, 2011	Richard Rivera-Lugo
--------------	--------------------------	-----------------	----------	---	---	---------------------

Milestone Description	Original Dat	Revised Date
Due to J. Parks	3/30/2011	
Due to OIS	3/31/2011	

Action Items for Division RES

Task Source	Roadmap	Reference	DIR/Branch	Task Description	Special Instructions	Current Status	Responsible
RES #2010519	<input type="checkbox"/>	FOIA #2011-0119	RES NONE	March 11th Earthquake (Due to J. Parks)	Please provide all information as stated in the request to J. Parks by COB March 30, 2011		Brett Rini
				Milestone Description	Original Dat	Revised Date	
				Due to J. Parks	3/30/2011		
				Due to OIS	3/30/2011		
RES #2010305	<input type="checkbox"/>		RES NONE	ROMA Query Report (Review ROMA Report)			Brett Rini
				Milestone Description	Original Dat	Revised Date	
				Review ROMA Report	11/23/2010	4/1/2011	
RES #2010409	<input type="checkbox"/>		RES NONE	Revising OI-PRM-001: Process for New Work Requests (EDATS:RES-2011-0011) (Task 3)	Task 1: Incorporate comments and provide TAs Task 2: Send revised OI to Jazel, Task 3: Send Jazel announcement of OI publication		Brett Rini
				Milestone Description	Original Dat	Revised Date	
				Task 3	3/24/2011	4/4/2011	
RES #2010530	<input type="checkbox"/>	FOIA #2011-0140	RES NONE	MSNBC FOIA REGARDING MARCH 11th EARTHQUAKE (Due to H. Dempsey)	Please provide all email or electronic messages sent or recieved including any attachments whether sent internally or externally from 12:00 am. ET on 3/11 through 11:59 ET on Friday 3/18 on Jennifer Uhle. Please provide all records to H.Dempsey on 4/6/11		Brett Rini
				Milestone Description	Original Dat	Revised Date	
				Due to H. Dempsey	4/6/2011		
				Due to OIS	4/8/2011		

Action Items for Division RES

Task Source	Roadmap	Reference	DIR/Branch	Task Description	Special Instructions	Current Status	Responsible
-------------	---------	-----------	------------	------------------	----------------------	----------------	-------------

RES #2010531	<input type="checkbox"/>	FOIA #2011-0140	DRA PRAB	MSNBC FOIA REGARDING MARCH 11TH EARTHQUAKE (Due to H. Dempsey)	Please provide all email or electronic messages sent or reviewed including any attachments whether sent internally or externally from 12:00 am. ET on 3/11 through 11:59 ET on Friday 3/18 on Jennifer Uhle. Please provide all records to H.Dempsey on 4/6/11		Jose Ibarra
--------------	--------------------------	-----------------	----------	--	--	--	-------------

Milestone Description	Original Dat	Revised Date
-----------------------	--------------	--------------

Due to H. Dempsey	4/6/2011	
-------------------	----------	--

Due to OIS	4/8/2011	
------------	----------	--

RES #2010532	<input type="checkbox"/>	FOIA #2011-0141	DE NONE	MSNBC FOIA REGARDING MARCH 11TH EARTHQUAKE (Due to H. Dempsey)	Please provide all electronic communication received including attachments sent internally or externally from 12:00 am ET on 3/11 to 11:59 ET on 3/25 from the people highlighted on the request to H. Dempsey by 04/06/2011		Richard Rivcra-Lugo
--------------	--------------------------	-----------------	---------	--	--	--	---------------------

Milestone Description	Original Dat	Revised Date
-----------------------	--------------	--------------

Due to H. Dempsey	4/6/2011	
-------------------	----------	--

Due to OIS	4/8/2011	
------------	----------	--

RES #2010533	<input type="checkbox"/>	FOIA #2011-0141	DRA NONE	(Due to H. Dempsey)	Please provide all electronic communication sent or recieved including any attachments whether sent internally or externally from 12:00 am. ET on 3/11 through 11:59 ET on 3/25 on the highlighted people. Please provide all records to H.Dempsey on 4/6/11		Jose Ibarra
--------------	--------------------------	-----------------	----------	---------------------	--	--	-------------

Milestone Description	Original Dat	Revised Date
-----------------------	--------------	--------------

Due to H. Dempsey	4/6/2011	
-------------------	----------	--

Due to OIS	4/8/2011	
------------	----------	--

Action Items for Division RES

Task Source Roadmap Reference	DIR/Branch	Task Description	Special Instructions	Current Status	Responsible
RES #2010534 <input type="checkbox"/>	FOIA #2011-0141	RES NONE	MSNBC FOIA Regarding March 11th EARTHQUAKE (Due to H. Dempsey)		Brett Rini

Please provide all email or electronic messages sent or reviewed including any attachments whether sent internally or externally from 12:00 am. ET on 3/11 through 11:59 ET on 3/25 on Brian Sheron. Please provide all records to H.Dempsey on 4/6/11

Milestone Description	Original Dat	Revised Date
Due to H. Dempsey	4/6/2011	
Due to OIS	4/8/2011	

RES #2010535 <input type="checkbox"/>	FOIA #2011-0141	RES NONE	MSNBC FOIA REGARDING MARCH 11TH EARTHQUAKE (Due to H. Dempsey)		Joseph Zabel
---------------------------------------	-----------------	----------	--	--	--------------

Please provide all email or electronic messages sent or reviewed including any attachments whether sent internally or externally from 12:00 am. ET on 3/11 through 11:59 ET on 3/25 on Joseph Zabel. Please provide all records to H.Dempsey on 4/6/11

Milestone Description	Original Dat	Revised Date
Due to H. Dempsey	4/6/2011	
Due to OIS	4/8/2011	

RES #2010214 <input type="checkbox"/>		RES NONE	Provide final MTT Summer Safety Course Presentation (Input from Divisions)		Brett Rini
---------------------------------------	--	----------	--	--	------------

Division to provide input on presentation by 4/15/2011

Milestone Description	Original Dat	Revised Date
Input from Divisions	4/15/2011	
Due to FO	5/2/2011	

From: [LIA07 Hoc](#)
Subject: Revised USNRC Earthquake-Tsunami Update -- 1800 EDT, March 25, 2011
Date: Friday, March 25, 2011 7:55:39 PM
Attachments: [USNRC Earthquake-Tsunami Update 032511 1800EDT\(rev2\).pdf](#)

Resent to add new dose and evacuation information.
Sorry for any confusion!

Attached, please find an 1800 EDT (March 25, 2011) status update from the US Nuclear Regulatory Commission's Emergency Operations Center regarding the impacts of the earthquake/tsunami.

Please note that this information is "Official Use Only" and is only being shared within the federal family.

Please call the Headquarters Operations Officer at 301-816-5100 with questions.

-Sara

Sara K. Mroz
Communications and Outreach
Office of Nuclear Security and Incident Response
US Nuclear Regulatory Commission
Sara.Mroz@nrc.gov
LIA07.HOC@nrc.gov (Operations Center)

CH/420

From: LIA07 Hoc
To: Borchardt, Bill; Bradford, Anna; Cohen, Shari; Cooper, LaToya; Dyer, Jim; Flory, Shirley; Gibbs, Catina; Haney, Catherine; Hudson, Sharon; Jaczko, Gregory; Johnson, Michael; Leeds, Eric; Loyd, Susan; Pace, Patti; Schwarz, Sherry; Sheron, Brian; Speiser, Herald; Sprogeris, Patricia; Taylor, Renee; Virgilio, Martin; Walls, Lorena; Weber, Michael
Subject: Revised Status Update (Round 2)
Date: Friday, March 25, 2011 7:58:45 PM
Attachments: USNRC Earthquake-Tsunami Update 032511 1800EDT(rev2).pdf

I was asked to revise the Status Update to include new dose and evacuation information.
The new version is attached. Sorry for any confusion!

From: LIA07 Hoc
Sent: Friday, March 25, 2011 7:10 PM
To: Borchardt, Bill; Bradford, Anna; Cohen, Shari; Cooper, LaToya; Dyer, Jim; Flory, Shirley; Gibbs, Catina; Haney, Catherine; Hudson, Sharon; Jaczko, Gregory; Johnson, Michael; Leeds, Eric; Loyd, Susan; Pace, Patti; Schwarz, Sherry; Sheron, Brian; Speiser, Herald; Sprogeris, Patricia; Taylor, Renee; Virgilio, Martin; Walls, Lorena; Weber, Michael
Subject: Revised Status Update

Resending the 1800EDT Status Update (to remove the "Draft" watermark)
Sorry for any confusion.
-Sara

From: LIA07 Hoc
Sent: Friday, March 25, 2011 6:56 PM
To: Borchardt, Bill; Bradford, Anna; Cohen, Shari; Cooper, LaToya; Dyer, Jim; Flory, Shirley; Gibbs, Catina; Haney, Catherine; Hudson, Sharon; Jaczko, Gregory; Johnson, Michael; Leeds, Eric; Loyd, Susan; Pace, Patti; Schwarz, Sherry; Sheron, Brian; Speiser, Herald; Sprogeris, Patricia; Taylor, Renee; Virgilio, Martin; Walls, Lorena; Weber, Michael
Subject: Update for Go Books - 1800 EDT, March 25, 2011

Please find attached updated information for the "Go Books".

The updates include:

- The 1800 EDT, 03/25/11 Status Update
- The latest ET Chronology
- The latest TEPCO Press Releases (Numbers 152-162)
- NRC Talking Points (GI-199)
- "One Pager" (1500 EDT, 03/25/11)

Please let me know if you have any questions or concerns.

-Sara

Sara Mroz
Communications and Outreach
Office of Nuclear Security and Incident Response
US Nuclear Regulatory Commission
Sara.Mroz@nrc.gov

CH/421

LIA07.HOC@nrc.gov (Operations Center)

From: RES DSA Calendar Resource
To: Schaperow, Jason; Shaffer, Vered; Bush-Goddard, Stephanie; Lewis, Robert; McDermott, Brian; Elkins, Scott; Milligan, Patricia; Jones, Cynthia; Holahan, Vincent; Cool, Donald; Pessin, Andrew; Sherbini, Sami
Cc: Williams, Kevin; Miller, Charles; Sheron, Brian; Uhle, Jennifer; Gibson, Kathy; Brandon, Lou; Brown, Frederick; Tinkler, Charles; Holahan, Patricia
Subject: FW: EDO Alignment: Japanese Earthquake Status – Focus on Health Effects of Radiation

When: Monday, March 28, 2011 3:00 PM-4:00 PM (GMT-05:00) Eastern Time (US & Canada).
Where: O17-B04

Note: The GMT offset above does not reflect daylight saving time adjustments.

~~*~*~*~*~*~*~*~*

RES, FSME and NSIR,

You are cordially invited to an EDO Alignment meeting

When and Where: Monday, March 28th, in O17-B04 from 3 to 4pm.

Why: Get aligned on a Commission meeting (April 14th) to provide an update of the Japanese nuclear event, discuss NRCs radiation protection strategies in emergency situations and hear a representative sample of external stakeholder viewpoints.

Thanks
-Stephanie Bush-Goddard
Chief, Health Effects Branch
Office of Nuclear Regulatory Research
301-251-7528

CH/422

From: RES DSA Calendar Resource
To: Schaperow, Jason; Shaffer, Vered; Bush-Goddard, Stephanie; Lewis, Robert; McDermott, Brian; Elkins, Scott; Milligan, Patricia; Jones, Cynthia; Holahan, Vincent; Cool, Donald; Pessin, Andrew; Sherbini, Sami
Cc: Williams, Kevin; Miller, Charles; Sheron, Brian; Uhle, Jennifer; Gibson, Kathy; Brandon, Lou; Brown, Frederick; Tinkler, Charles; Holahan, Patricia
Subject: FW: EDO Alignment: Japanese Earthquake Status – Focus on Health Effects of Radiation

When: Monday, March 28, 2011 3:00 PM-4:00 PM (GMT-05:00) Eastern Time (US & Canada).
Where: O17-B04

Note: The GMT offset above does not reflect daylight saving time adjustments.

~~*~*~*~*~*~*~*~*

RES, FSME and NSIR,

You are cordially invited to an EDO Alignment meeting

When and Where: Monday, March 28th, in O17-B04 from 3 to 4pm.

Why: Get aligned on a Commission meeting (April 14th) to provide an update of the Japanese nuclear event, discuss NRCs radiation protection strategies in emergency situations and hear a representative sample of external stakeholder viewpoints.

Thanks
-Stephanie Bush-Goddard
Chief, Health Effects Branch
Office of Nuclear Regulatory Research
301-251-7528

CA/423

From: Sheron, Brian on behalf of ConferenceRoomO17B4 Resource
To: Flory, Shirley; Uhle, Jennifer; Muessle, Mary; Valentin, Andrea; Virgilio, Martin; Weber, Michael; Ash, Darren; Borchardt, Bill; Kasputys, Clare; Johnson, Michael; Holahan, Gary; Leeds, Eric; Boger, Bruce; Grobe, Jack; Andersen, James; Dean, Bill; McCree, Victor; Satorius, Mark; Collins, Elmo; Sheron, Brian; Wiggins, Jim; Doane, Margaret; Mamish, Nader; McCrary, Cheryl; Zimmerman, Roy; Burns, Stephen
Cc: Dyer, Jim; Hudson, Sharon; Gusack, Barbara; Schum, Constance; Murphy, Jerome; Lin, Chien-Ting; Givvines, Mary; Ferrell, Kimberly; Nguyen, Caroline; Newell, Karenina; Whetstine, Jack; Gallo, Jenny; Ma, May; Harvey, Sue; Campbell, Andy; Krupnick, David; Shnayder, Yana; Baker, Pamela; Brand, MaryLynn; Coleman, Judy; Hunter, James; McGill, Clinton; Holt, BJ; Sotiropoulos, Dina; Butler, Rodney; Bayliff, Shirley; Hays, Myra; Gardin, Kathy; Nute-Blackshear, Lora; Grancorvitz, Teresa; Spencer, Ruth; Sprogeris, Patricia; Schwarz, Sherry; Salus, Amy; Riddick, Nicole; Boyd, Lena; Veltri, Debra; Jacobs-Baynard, Elizabeth; Smolik, George; Allwein, Russell; Dhir, Neha
Subject: FW: FY 2013 Budget Reviews (OCFO/DEDR)
Attachments: Meeting Schedule EDO-DEDO Mtgs - Marty.doc
RE VTC Request.msg

-----Original Appointment-----

From: ConferenceRoomO17B4 Resource
Sent: Monday, March 21, 2011 12:16 PM
To: ConferenceRoomO17B4 Resource; Muessle, Mary; Virgilio, Martin; Weber, Michael; Ash, Darren; Borchardt, Bill; Kasputys, Clare; Johnson, Michael; Holahan, Gary; Leeds, Eric; Boger, Bruce; Grobe, Jack; Andersen, James; Dean, Bill; McCree, Victor; Satorius, Mark; Collins, Elmo; Sheron, Brian; Uhle, Jennifer; Wiggins, Jim; Doane, Margaret; Mamish, Nader; McCrary, Cheryl; Zimmerman, Roy; Burns, Stephen
Cc: Dyer, Jim; Hudson, Sharon; Gusack, Barbara; Schum, Constance; Murphy, Jerome; Lin, Chien-Ting; Givvines, Mary; Ferrell, Kimberly; Nguyen, Caroline; Newell, Karenina; Whetstine, Jack; Gallo, Jenny; Ma, May; Harvey, Sue; Campbell, Andy; Krupnick, David; Shnayder, Yana; Baker, Pamela; Brand, MaryLynn; Coleman, Judy; Hunter, James; McGill, Clinton; Holt, BJ; Sotiropoulos, Dina; Butler, Rodney; Bayliff, Shirley; Hays, Myra; Gardin, Kathy; Nute-Blackshear, Lora; Grancorvitz, Teresa; Spencer, Ruth; Sprogeris, Patricia; Schwarz, Sherry; Salus, Amy; Riddick, Nicole; Boyd, Lena; Flory, Shirley; Veltri, Debra; Jacobs-Baynard, Elizabeth; Smolik, George; Allwein, Russell; Dhir, Neha
Subject: FY 2013 Budget Reviews (OCFO/DEDR)
When: Tuesday, April 05, 2011 9:00 AM-10:30 AM (GMT-05:00) Eastern Time (US & Canada).
Where: VTC (RGNS)/Bridgeline 1-888-790-6563 (b)(6) O-17B4

When: Tuesday, April 05, 2011 9:00 AM-10:30 AM (GMT-05:00) Eastern Time (US & Canada).
Where: VTC (RGNS)/Bridgeline 1-888-790-6563 (b)(6) O-17B4

Note: The GMT offset above does not reflect daylight saving time adjustments.

~~*~*~*~*~*~*~*~*

3/21/11 - Updated to include additional attendees (S. Cianci x1714)

Contacts:
Liz Jacobs-Baynard (415-8709)
Clare Kasputys (415-1767)

The VTC has been scheduled with the Regional Administrators' offices. A bridge line has been established as a back up: 1-888-790-6563, passcode (b)(6)

When: Tuesday, April 5, 2011 9:00 AM-10:30 AM Eastern Time.
Where: O17B4

~~*~*~*~*~*~*~*~*

A meeting has been scheduled for 4/5/11, 9:00am—10:30am, Room O17B4, with Marty Virgilio to discuss the Nuclear Reactor Safety Program FY 2013 Budget Request.

Purpose: To review and discuss key aspects of the FY 2013 budget request for the Nuclear Reactor Safety Program.

Outcome: (1) Understanding of major aspects of the FY 2013 base budget request for Business Lines; (2) Understanding of significant items in Scenario A (potential reductions) and Scenario B (potential additions), and the associated programmatic impacts and benefits.

Process: Lead offices should provide a brief budget overview of the Business Line and discuss the Business Line Summaries, including the base budget, Scenario A, and Scenario B. The discussion should not exceed 25 minutes for each Business Line, after which 40 minutes will be reserved for questions and answers. The schedule for Business Line discussions is as follows:

New Reactors (NRO) 9:00am - 9:25am

CH/424

Operating Reactors (NRR)

9:25am - 9:50am

Questions and Answers 9:50am - 10:30am

Rct 3/1

POC - Clare Kasputys

AGENDA

When: Tuesday, April 5, 2011 9:00 AM-10:30 AM Eastern Time.

Where: O17B4

~~*~*~*~*~*~*~*~*

A meeting has been scheduled for 4/5/11, 9:00am—10:30am, Room O17B4, with Marty Virgilio to discuss the Nuclear Reactor Safety Program FY 2013 Budget Request.

Purpose: To review and discuss key aspects of the FY 2013 budget request for the Nuclear Reactor Safety Program.

Outcome: (1) Understanding of major aspects of the FY 2013 base budget request for Business Lines; (2) Understanding of significant items in Scenario A (potential reductions) and Scenario B (potential additions), and the associated programmatic impacts and benefits.

Process: Lead offices should provide a brief budget overview of the Business Line and discuss the Business Line Summaries, including the base budget, Scenario A, and Scenario B. The discussion should not exceed 25 minutes for each Business Line, after which 40 minutes will be reserved for questions and answers. The schedule for Business Line discussions is as follows:

New Reactors (NRO)	9:00am - 9:25am
Operating Reactors (NRR)	9:25am - 9:50am
Questions and Answers	9:50am – 10:30am

The VTC has been scheduled with the Regional Administrators' offices. A bridge line has been established as a back up: 1-888-790-6563, passcode (b)(6)

Contacts:

Liz Jacobs-Baynard (415-8709)

Clare Kasputys (415-1767)

Attachment RE VTC Request.msg (2560 Bytes) cannot be converted to PDF format.

From: Sheron, Brian on behalf of ConferenceRoom017B4 Resource
To: Flory, Shirley; Uhle, Jennifer; Virgilio, Martin; Valentin, Andrea; Ash, Darren; Weber, Michael; Muesle, Mary; Borhardt, Bill; Kasputys, Clare; Haney, Catherine; Dorman, Dan; Miller, Charles; Moore, Scott; Wiggins, Jim; Burns, Stephen; Sheron, Brian; Zimmerman, Roy; Dean, Bill; McCree, Victor; Satorius, Mark; Collins, Elmo; McCrary, Cheryl; Doane, Margaret; Andersen, James
Cc: Dyer, Jim; Hudson, Sharon; Pulliam, Timothy; Fitch, Karen; Rand, Jennifer; Neff, Deborah; Green, Jamie; Ma, May; Harvey, Sue; Shnyder, Yana; Grancorvitz, Teresa; Spencer, Ruth; Campbell, Andy; McDevitt, Joan; Baker, Pamela; Brand, MaryLynn; Coleman, Judy; Hunter, James; McGill, Clinton; Holt, BJ; Sotiropoulos, Dina; Butler, Rodney; Bayliff, Shirley; Hays, Myra; Gardin, Kathy; Nute-Blackshear, Lora; Whetstone, Jack; Gallo, Jenny; Casby, Marcia; Walker, Dwight; Salus, Amy; Riddick, Nicole; Boyd, Lena; Veltri, Debra; Jacobs-Baynard, Elizabeth; Smolik, George; Allwein, Russell; Dhir, Neha
Subject: FW: FY 2013 Budget Reviews (OCFO/DEDMRT)
Attachments: Meeting Schedule EDO-DEDO Mtgs - Mike.doc

-----Original Appointment-----

From: ConferenceRoom017B4 Resource
Sent: Monday, March 21, 2011 12:33 PM
To: ConferenceRoom017B4 Resource; Virgilio, Martin; Ash, Darren; Weber, Michael; Muesle, Mary; Borhardt, Bill; Kasputys, Clare; Haney, Catherine; Dorman, Dan; Miller, Charles; Moore, Scott; Wiggins, Jim; Burns, Stephen; Sheron, Brian; Uhle, Jennifer; Zimmerman, Roy; Dean, Bill; McCree, Victor; Satorius, Mark; Collins, Elmo; McCrary, Cheryl; Doane, Margaret; Andersen, James
Cc: Dyer, Jim; Hudson, Sharon; Pulliam, Timothy; Fitch, Karen; Rand, Jennifer; Neff, Deborah; Green, Jamie; Ma, May; Harvey, Sue; Shnyder, Yana; Grancorvitz, Teresa; Spencer, Ruth; Campbell, Andy; McDevitt, Joan; Baker, Pamela; Brand, MaryLynn; Coleman, Judy; Hunter, James; McGill, Clinton; Holt, BJ; Sotiropoulos, Dina; Butler, Rodney; Bayliff, Shirley; Hays, Myra; Gardin, Kathy; Nute-Blackshear, Lora; Whetstone, Jack; Gallo, Jenny; Casby, Marcia; Walker, Dwight; Salus, Amy; Riddick, Nicole; Boyd, Lena; Flory, Shirley; Veltri, Debra; Jacobs-Baynard, Elizabeth; Smolik, George; Allwein, Russell; Dhir, Neha
Subject: FY 2013 Budget Reviews (OCFO/DEDMRT)
When: Wednesday, April 06, 2011 1:30 PM-3:30 PM (GMT-05:00) Eastern Time (US & Canada).
Where: Bridgeline 1-888-790-6563, passcode (b)(6) P-17B4

When: Wednesday, April 06, 2011 1:30 PM-3:30 PM (GMT-05:00) Eastern Time (US & Canada).
Where: Bridgeline 1-888-790-6563, passcode (b)(6) P-17B4

Note: The GMT offset above does not reflect daylight saving time adjustments.

~~*~*~*~*~*~*~*~*

3/21/11 - Updated to include additional attendees (S. Cianci x1714)

Contacts:
Liz Jacobs-Baynard (415-8709)
Clare Kasputys (415-1767)

A bridge line has been established for this meeting: 1-888-790-6563, passcode (b)(6)

When: Wednesday, April 6, 2011 1:30 PM-3:30 PM Eastern Time.
Where: O17B4

~~*~*~*~*~*~*~*~*

A meeting has been scheduled for 4/6/11, 1:30pm-3:30pm, Room O17B4, with Mike Weber to discuss the Nuclear Materials and Waste Safety Program FY 2013 Budget Request.

Purpose: To review and discuss key aspects of the FY 2013 budget request for the Nuclear Materials and Waste Safety Program.

Outcome: (1) Understanding of major aspects of the FY 2013 base budget request for the Nuclear Materials and Waste Safety program; (2) Understanding of significant items in Scenario A (potential reductions) and Scenario B (potential additions), and the associated programmatic impacts and benefits.

Process: Lead offices should provide a brief budget overview of the Business Line and discuss the Business Lines Summaries, including the base budget, Scenario A, and Scenario B. The discussion should not exceed approximately 25 minutes for each Business Line, after which 20 minutes will be reserved for questions and answers. The schedule for Business Line discussions is as follows:

Fuel Facilities (NMSS) 1:30pm - 1:55pm

Spent Fuel Storage and Transportation (NMSS) 1:55pm - 2:20pm

Nuclear Materials Users (FSME) 2:20pm - 2:45pm

CH/425

Decommissioning and Low-Level Waste (FSME) 2:45pm – 3:10pm

Questions and Answers 3:10pm – 3:30pm

Rct 3/1

POC – Clare Kasputys

AGENDA

When: Wednesday, April 6, 2011 1:30 PM-3:30 PM Eastern Time.

Where: O17B4

~~*~*~*~*~*~*~*~*

A meeting has been scheduled for 4/6/11, 1:30pm—3:30pm, Room O17B4, with Mike Weber to discuss the Nuclear Materials and Waste Safety Program FY 2013 Budget Request.

Purpose: To review and discuss key aspects of the FY 2013 budget request for the Nuclear Materials and Waste Safety Program.

Outcome: (1) Understanding of major aspects of the FY 2013 base budget request for the Nuclear Materials and Waste Safety program; (2) Understanding of significant items in Scenario A (potential reductions) and Scenario B (potential additions), and the associated programmatic impacts and benefits.

Process: Lead offices should provide a brief budget overview of the Business Line and discuss the Business Lines Summaries, including the base budget, Scenario A, and Scenario B. The discussion should not exceed approximately 25 minutes for each Business Line, after which 20 minutes will be reserved for questions and answers. The schedule for Business Line discussions is as follows:

Fuel Facilities (NMSS)	1:30pm – 1:55pm
Spent Fuel Storage and Transportation (NMSS)	1:55pm – 2:20pm
Nuclear Materials Users (FSME)	2:20pm – 2:45pm
Decommissioning and Low-Level Waste (FSME)	2:45pm – 3:10pm
Questions and Answers	3:10pm – 3:30pm

A bridge line has been established for this meeting: 1-888-790-6563, passcode (b)(6)

Contacts:
Liz Jacobs-Baynard (415-8709)
Clare Kasputys (415-1767)

From: Sheron, Brian on behalf of Dyer, Jim
To: Uhle, Jennifer; Valentin, Andrea; Taylor, Renee; Smolik, George; Golder, Jennifer; Powell, Marlon; Brown, Milton; Borchardt, Bill; Ash, Darren; Weber, Michael; Muessle, Mary; Virgilio, Martin; Hudson, Sharon; Matakas, Gina; Miles, Patricia; Buckley, Patricia; Owen, Lucy; Collins, Elmo; Satorius, Mark; Reyes, Luis; Casto, Chuck; Dapas, Marc; Kelley, Corenthis; Sheron, Brian; Boyce, Thomas (OIS); McCrary, Cheryl; Zimmerman, Roy; Wiggins, Jim; Leeds, Eric; Johnson, Michael; Haney, Catherine; Cohen, Miriam; Miller, Charles; Howard, Patrick; Greene, Kathryn; Doane, Margaret; Poole, Brooke; Schmidt, Rebecca; Brenner, Eliot; Vietti-Cook, Annette; Burns, Stephen; Hackett, Edwin; Jacobs-Baynard, Elizabeth; Kasputys, Clare; McCree, Victor; Dubose, Sheila
Cc: Flory, Shirley; Lee, Pamela; Webber, Robert; Delligatti, Mark; Green, Jamie; Neff, Deborah; Quesenberry, Jeannette; Wright, Darlene; Joosten, Sandy; Evans, Michele; Gallo, Jenny; Bellinger, Alesha; Perry, Jamila; Lewis, Antoinette; Cooper, Kiona; Sentz, Brian; Tannenbaum, Anita; Bettis, Ashley; Moore, Scott; Stewart, Sharon; Allwein, Russell; Baum, Richard; Metzgar, Laura; Miller, Fred; Murray, Heather; Ojeda, Jennifer; Tabakov, Emil; Trybus, Chester; Wagner, Paige; Williams, Donald; Janis, James; New, Edward; Dove, Marna; Dhir, Neha; Newell, Karenina; Le, Hong; Murphy, Jerome; Fitch, Karen; Akstulewicz, Brenda; Gusack, Barbara; Ronewicz, Lynn; Sheldon, Jeffrey; Ricketts, Paul; McDevitt, Joan; Powell, Amy; Campbell, Andy; Stehlin, Barbara; Sall, Basia; Dabbs, Bill; Holt, BJ; Nelson-Wilson, Carlyleamaryllis; Nguyen, Caroline; Lin, Chien-Ting; McGill, Clinton; Butler, Darrin; Decker, David; Krupnick, David; Rule, David; Huber, Deborah; Sotiropoulos, Dina; Hall, Donald; Gillen, Edward; Hayden, Elizabeth; Tharpe, Gary; Gulla, Gerald; Somerville, Glenda; Solorio, Ilka; Whetstone, Jack; Andersen, James; Horn, James; Hunter, James; Dambly, Jan; Shay, Jason; Rand, Jennifer; Johnson, Joanne; John Vassos; Coleman, Judy; Hannum, Karyn; Stout, Kathleen; ZilkaMayer, Kathleen; Gardin, Kathy; Ferrell, Kimberly; Boyd, Lena; Nute-Blackshear, Lora; Warner, MaryAnn; Brand, MaryLynn; Ma, May; Lockhart, Michelle; Tenaglia, Mickey; Lee, Min; Hays, Myra; Baker, Pamela; Humphreys, Patti; Nibert, Patty; Augustus, Reginald; Hopkins, Rhonda; Rough, Richard; Spiegel, Richard; Stanfield, Richard; Barnes, Robin; Butler, Rodney; Spencer, Ruth; Marks, Sharon; Bayliff, Shirley; Dembek, Stephen; Jefferson, Steven; Harvey, Sue; Blond, Tamoria; Grancorvitz, Teresa; McLaughlin, Terri; Walker, Tracy; Voytko, Victoria; Shnayder, Yana; Valentin, Andrea; Abraham, Susan; Rheaume, Cynthia; OE_Calendar Resource; Lee, David; Curran, Bridget; Pederson, Cynthia; R3 Activity Calendar Resource; Larche, Linda; Arrighi, Russell; Harris, Natasha; Hawkens, Roy; Holahan, Gary; Pulliam, Timothy; Schum, Constance; Jacobssen, Patricia; Solorio, Dave; Uhle, Jennifer
Subject: FW: FY 2013 Budget Chairman's Guidance with VTC and teleconference - see agenda and additional attachments (listed below)
Attachments: GS SRM-CmGB11-0001-final-31711.docx
GS Guidance Memo FINAL 3-22-11.docx
GS FY 2013 Budget Instructions FINAL 3-22-11.docx
Agenda CFO-EDO Budget Mtg 3-24-11.doc

Can you cover this tomorrow? I have to give the daily congressional staff briefing today and tomorrow from 3-4 pm.

-----Original Appointment-----

From: Dyer, Jim

Sent: Thursday, December 23, 2010 2:31 PM

To: Dyer, Jim; Taylor, Renee; Smolik, George; Golder, Jennifer; Powell, Marlon; Brown, Milton; Borchardt, Bill; Ash, Darren; Weber, Michael; Muessle, Mary; Virgilio, Martin; Hudson, Sharon; Matakas, Gina; Miles, Patricia; Buckley, Patricia; Owen, Lucy; Collins, Elmo; Satorius, Mark; Reyes, Luis; Casto, Chuck; Dapas, Marc; Kelley, Corenthis; Sheron, Brian; Boyce, Thomas (OIS); McCrary, Cheryl; Zimmerman, Roy; Wiggins, Jim; Leeds, Eric; Johnson, Michael; Haney, Catherine; Cohen, Miriam; Miller, Charles; Howard, Patrick; Greene, Kathryn; Doane, Margaret; Poole, Brooke; Schmidt, Rebecca; Brenner, Eliot; Vietti-Cook, Annette; Burns, Stephen; Hackett, Edwin; Jacobs-Baynard, Elizabeth; Kasputys, Clare; McCree, Victor; Dubose, Sheila

Cc: Flory, Shirley; Lee, Pamela; Webber, Robert; Delligatti, Mark; Green, Jamie; Neff, Deborah; Quesenberry, Jeannette; Wright, Darlene; Joosten, Sandy; Evans, Michele; Gallo, Jenny; Bellinger, Alesha; Perry, Jamila; Lewis, Antoinette; Cooper, Kiona; Sentz, Brian; Tannenbaum, Anita; Bettis, Ashley; Moore, Scott; Stewart, Sharon; Allwein, Russell; Baum, Richard; Metzgar, Laura; Miller, Fred; Murray, Heather; Ojeda, Jennifer; Tabakov, Emil; Trybus, Chester; Wagner, Paige; Williams, Donald; Janis, James; New, Edward; Dove, Marna; Dhir, Neha; Newell, Karenina; Le, Hong; Murphy, Jerome; Fitch, Karen; Akstulewicz, Brenda; Gusack, Barbara; Ronewicz, Lynn; Sheldon, Jeffrey; Ricketts, Paul; McDevitt, Joan; Powell, Amy; Campbell, Andy; Stehlin, Barbara; Sall, Basia; Dabbs, Bill; Holt, BJ; Nelson-Wilson, Carlyleamaryllis; Nguyen, Caroline; Lin, Chien-Ting; McGill, Clinton; Butler, Darrin; Decker, David; Krupnick, David; Rule, David; Huber, Deborah; Sotiropoulos, Dina; Hall, Donald; Gillen, Edward; Hayden, Elizabeth; Tharpe, Gary; Gulla, Gerald; Somerville, Glenda; Solorio, Ilka; Whetstone, Jack; Andersen, James; Horn, James; Hunter, James; Dambly, Jan; Shay, Jason; Rand, Jennifer; Johnson, Joanne; John Vassos ([HYPERLINK "mailto:John.Vassos@nrc.ogv"](mailto:John.Vassos@nrc.ogv) John.Vassos@nrc.ogv); Coleman, Judy; Hannum, Karyn; Stout, Kathleen; Zilka, Kathleen; Gardin, Kathy; Ferrell, Kimberly; Boyd, Lena; Nute-Blackshear, Lora; Warner, MaryAnn; Brand, MaryLynn; Ma, May; Lockhart, Michelle; Tenaglia, Mickey; Lee, Min; Hays, Myra; Baker, Pamela; Humphreys, Patti; Nibert, Patty; Augustus, Reginald; Hopkins, Rhonda; Rough, Richard; Spiegel, Richard; Stanfield, Richard; Barnes, Robin; Butler, Rodney; Spencer, Ruth; Marks, Sharon; Bayliff, Shirley; Dembek, Stephen; Jefferson, Steven; Harvey, Sue; Blond, Tamoria; Grancorvitz, Teresa; McLaughlin, Terri; Walker, Tracy; Voytko, Victoria; Shnayder, Yana; Valentin, Andrea; Abraham, Susan; Rheaume, Cynthia; OE_Calendar Resource; Lee, David; Curran, Bridget; Pederson, Cynthia; R3_Activity_Calendar Resource; Larche, Linda; Arrighi, Russell; Harris, Natasha; Hawkens, Roy; Holahan, Gary; Pulliam, Timothy; Schum, Constance; Jacobssen, Patricia; Solorio, Dave; Uhle, Jennifer

Subject: FY 2013 Budget Chairman's Guidance with VTC and teleconference - see agenda and additional attachments (listed below)

When: Thursday, March 24, 2011 4:00 PM-5:30 PM (GMT-05:00) Eastern Time (US & Canada).

Where: Commissioners' hearing room

CH/426

Dial In: 800-779-9286

Pass code: (b)(6)

VTC to Regions:

NRC HQ – Sharon Hudson 301-415-7322

Region I – Gina Matakis 610-337-5105

Region II – Pat Miles 404-562-4413

Region III – Pat Buckley 603-829-9657

Region IV - Lucy Owen 817-860-8227

NOTE: The VTC will also be used for the last 30 minutes for OCFO/OEDO to meet with budget contacts.

Sharon M. Hudson
Administrative Assistant for the CFO and Deputy CFO
Office of the Chief Financial Officer
301-415-7322

(b)(5)

**OFFICIAL USE ONLY - SENSITIVE INTERNAL INFORMATION -
LIMITED TO NRC UNLESS THE COMMISSION DETERMINES OTHERWISE**

(b)(5)

(b)(5)

(b)(5)

(b)(5)

(b)(5)

(b)(5)

(b)(5)

(b)(5)

(b)(5)

(b)(5)

(b)(5)

(b)(5)

(b)(5)

(b)(5)

(b)(5)

(b)(5)

(b)(5)

(b)(5)

(b)(5)

(b)(5)

(b)(5)

(b)(5)

(b)(5)

(b)(5)

(b)(5)

(b)(5)

From: Sheron, Brian on behalf of Dyer, Jim
To: Flory, Shirley; Uhle, Jennifer; Taylor, Renee; Valentin, Andrea; Smolik, George; Grancorvitz, Teresa; Golder, Jennifer; Powell, Marlon; Brown, Milton; Borchardt, Bill; Ash, Darren; Weber, Michael; Muessle, Mary; Virgilio, Martin; Hudson, Sharon; Matakas, Gina; Miles, Patricia; Buckley, Patricia; Owen, Lucy; Collins, Elmo; Satorius, Mark; Reyes, Luis; Casto, Chuck; Dapas, Marc; Kelley, Corenthis; Sheron, Brian; Boyce, Thomas (OIS); McCrary, Cheryl; Zimmerman, Roy; Wiggins, Jim; Leeds, Eric; Johnson, Michael; Haney, Catherine; Cohen, Miriam; Miller, Charles; Howard, Patrick; Greene, Kathryn; Doane, Margaret; Poole, Brooke; Schmidt, Rebecca; Brenner, Eliot; Vietti-Cook, Annette; Burns, Stephen; Hackett, Edwin; Jacobs-Baynard, Elizabeth; Kasoutys, Clare; McCree, Victor; Dubose, Sheila
Cc: Lee, Pamela; Webber, Robert; Delligatti, Mark; Green, Jamie; Neff, Deborah; Quesenberry, Jeannette; Wright, Darlene; Joosten, Sandy; Evans, Michele; Gallo, Jenny; Bellinger, Alesha; Perry, Jamila; Lewis, Antoinette; Cooper, Kiona; Sentz, Brian; Tannenbaum, Anita; Bettis, Ashley; Moore, Scott; Stewart, Sharon; Allwein, Russell; Baum, Richard; Metzgar, Laura; Miller, Fred; Murray, Heather; Ojeda, Jennifer; Tabakov, Emil; Trybus, Chester; Wagner, Paige; Williams, Donald; Janis, James; New, Edward; Dove, Marna; Dhir, Neha; Newell, Karenina; Le, Hong; Murphy, Jerome; Fitch, Karen; Akstulewicz, Brenda; Gusack, Barbara; Ronewicz, Lynn; Sheldon, Jeffrey; Ricketts, Paul; McDevitt, Joan; Powell, Amy; Campbell, Andy; Stehlin, Barbara; Sall, Basia; Dabbs, Bill; Holt, BJ; Nelson-Wilson, Carlyeamaryllis; Nguyen, Caroline; Lin, Chien-Ting; McGill, Clinton; Butler, Darrin; Decker, David; Krupnick, David; Rule, David; Huber, Deborah; Sotiropoulos, Dina; Hall, Donald; Gillen, Edward; Hayden, Elizabeth; Tharpe, Gary; Gulla, Gerald; Somerville, Glenda; Solorio, Ilka; Whetstine, Jack; Andersen, James; Horn, James; Hunter, James; Dambly, Jan; Shay, Jason; Rand, Jennifer; Johnson, Joanne; John Vassos (John.Vassos@nrc.gov); Coleman, Judy; Hannum, Karyn; Stout, Kathleen; Zilka, Kathleen; Gardin, Kathy; Ferrell, Kimberly; Boyd, Lena; Nute-Blackshear, Lora; Warner, MaryAnn; Brand, MaryLynn; Ma, May; Lockhart, Michelle; Tenaglia, Mickey; Lee, Min; Hays, Myra; Baker, Pamela; Humphreys, Patti; Nibert, Patty; Augustus, Reginald; Hopkins, Rhonda; Rough, Richard; Speigel, Richard; Stanfield, Richard; Barnes, Robin; Butler, Rodney; Spencer, Ruth; Marks, Sharon; Bayliff, Shirley; Dembek, Stephen; Jefferson, Steven; Harvey, Sue; Blond, Tamoria; McLaughlin, Terri; Walker, Tracy; Voytko, Victoria; Shnayder, Yana; Abraham, Susan; Rheaume, Cynthia; OE_Calendar_Resource; Lee, David; Curran, Bridget; Pederson, Cynthia; R3_Activity_Calendar_Resource; Larche, Linda; Arrighi, Russell; Harris, Natasha; Hawkens, Roy; Holahan, Gary; Pulliam, Timothy; Schum, Constance; Jacobssen, Patricia; Solorio, Dave
Subject: FW: FY 2013 Budget Chairman's Guidance with VTC and teleconference - see agenda attached
Attachments: Agenda-CFO-EDO Budget Mtg 3-24-11.doc

-----Original Appointment-----

From: Dyer, Jim

Sent: Thursday, December 23, 2010 2:31 PM

To: Dyer, Jim; Taylor, Renee; Smolik, George; Golder, Jennifer; Powell, Marlon; Brown, Milton; Borchardt, Bill; Ash, Darren; Weber, Michael; Muessle, Mary; Virgilio, Martin; Hudson, Sharon; Matakas, Gina; Miles, Patricia; Buckley, Patricia; Owen, Lucy; Collins, Elmo; Satorius, Mark; Reyes, Luis; Casto, Chuck; Dapas, Marc; Kelley, Corenthis; Sheron, Brian; Boyce, Thomas (OIS); McCrary, Cheryl; Zimmerman, Roy; Wiggins, Jim; Leeds, Eric; Johnson, Michael; Haney, Catherine; Cohen, Miriam; Miller, Charles; Howard, Patrick; Greene, Kathryn; Doane, Margaret; Poole, Brooke; Schmidt, Rebecca; Brenner, Eliot; Vietti-Cook, Annette; Burns, Stephen; Hackett, Edwin; Jacobs-Baynard, Elizabeth; Kasoutys, Clare; McCree, Victor; Dubose, Sheila

Cc: Flory, Shirley; Lee, Pamela; Webber, Robert; Delligatti, Mark; Green, Jamie; Neff, Deborah; Quesenberry, Jeannette; Wright, Darlene; Joosten, Sandy; Evans, Michele; Gallo, Jenny; Bellinger, Alesha; Perry, Jamila; Lewis, Antoinette; Cooper, Kiona; Sentz, Brian; Tannenbaum, Anita; Bettis, Ashley; Moore, Scott; Stewart, Sharon; Allwein, Russell; Baum, Richard; Metzgar, Laura; Miller, Fred; Murray, Heather; Ojeda, Jennifer; Tabakov, Emil; Trybus, Chester; Wagner, Paige; Williams, Donald; Janis, James; New, Edward; Dove, Marna; Dhir, Neha; Newell, Karenina; Le, Hong; Murphy, Jerome; Fitch, Karen; Akstulewicz, Brenda; Gusack, Barbara; Ronewicz, Lynn; Sheldon, Jeffrey; Ricketts, Paul; McDevitt, Joan; Powell, Amy; Campbell, Andy; Stehlin, Barbara; Sall, Basia; Dabbs, Bill; Holt, BJ; Nelson-Wilson, Carlyeamaryllis; Nguyen, Caroline; Lin, Chien-Ting; McGill, Clinton; Butler, Darrin; Decker, David; Krupnick, David; Rule, David; Huber, Deborah; Sotiropoulos, Dina; Hall, Donald; Gillen, Edward; Hayden, Elizabeth; Tharpe, Gary; Gulla, Gerald; Somerville, Glenda; Solorio, Ilka; Whetstine, Jack; Andersen, James; Horn, James; Hunter, James; Dambly, Jan; Shay, Jason; Rand, Jennifer; Johnson, Joanne; John Vassos ([HYPERLINK "mailto:John.Vassos@nrc.gov"](mailto:John.Vassos@nrc.gov) John.Vassos@nrc.gov); Coleman, Judy; Hannum, Karyn; Stout, Kathleen; Zilka, Kathleen; Gardin, Kathy; Ferrell, Kimberly; Boyd, Lena; Nute-Blackshear, Lora; Warner, MaryAnn; Brand, MaryLynn; Ma, May; Lockhart, Michelle; Tenaglia, Mickey; Lee, Min; Hays, Myra; Baker, Pamela; Humphreys, Patti; Nibert, Patty; Augustus, Reginald; Hopkins, Rhonda; Rough, Richard; Speigel, Richard; Stanfield, Richard; Barnes, Robin; Butler, Rodney; Spencer, Ruth; Marks, Sharon; Bayliff, Shirley; Dembek, Stephen; Jefferson, Steven; Harvey, Sue; Blond, Tamoria; Grancorvitz, Teresa; McLaughlin, Terri; Walker, Tracy; Voytko, Victoria; Shnayder, Yana; Valentin, Andrea; Abraham, Susan; Rheaume, Cynthia; OE_Calendar_Resource; Lee, David; Curran, Bridget; Pederson, Cynthia; R3_Activity_Calendar_Resource; Larche, Linda; Arrighi, Russell; Harris, Natasha; Hawkens, Roy; Holahan, Gary; Pulliam, Timothy; Schum, Constance; Jacobssen, Patricia; Solorio, Dave

Subject: FY 2013 Budget Chairman's Guidance with VTC and teleconference - see agenda attached

When: Thursday, March 24, 2011 4:00 PM-5:30 PM (GMT-05:00) Eastern Time (US & Canada).

Where: Commissioners' hearing room

When: Thursday, March 24, 2011 4:00 PM-5:30 PM (GMT-05:00) Eastern Time (US & Canada).

Where: Commissioners' hearing room

Note: The GMT offset above does not reflect daylight saving time adjustments.

~~*~*~*~*~*~*~*~*

CH/427

Your conference details are enclosed.

Meeting Information:

Leader: SHARON HUDSON
Phone number: 1-301-415-7322
Contact: MR TYRONE BROWN
Phone number: 1-301-415-7027
Call date: MAR-24-2011 (Thursday)
Call time: 04:00 PM EASTERN TIME
Duration: 1 hr 30 min
Service level: Unattended
Number of lines: Total=20 Dialout=0 Meet Me=20 Meet Me Toll=0
Confirmation number: 2434640
Company: FTS-NUCLEAR REGULATORY COMMISI
CRC:

Passcodes/Pin codes:

~~Participant passcode:~~ (b)(6)

For security reasons, the passcode will be required to join the call.

Dial in numbers:

Country Toll Numbers Freephone/
Toll Free Number

USA

~~800-779-9286~~

Restrictions may exist when accessing freephone/toll free numbers using a mobile telephone.

In-Conference Features:

All participants must use a touch-tone phone to participate in an Audio Conference. The following features are available for you to use on your phone during an active conference:

- ◆ Press *0 operator assistance (small fee may apply)
- ◆ Press *6 mute/unmute individual line

Selected Conference Features:

Audio
Tones

Leaders can schedule, modify or cancel a reservation by using e-Scheduling, our online reservation tool. To reschedule or cancel this reservation, click HYPERLINK "<https://www.mymeetings.com/custom/redirect.jsp?referer=/custom/res/content/escheduling/index.php>" here.

For additional assistance, contact customer service at ~~877-855-4797~~
Special notes:

Call notes: FEB-01-11 03:39 PM/CT KORVERM USA...changed the date from mar-3-2011 at 3:00 pm/et to mar-17-2011 at 1:00 pm/et, also increased the duration from 1.5 hours to 2 hours per mr. michael hackett at 301-415-7026.

The Conferencing Center would like to send you e-mail notes to keep you informed of new or enhanced products and services, conferencing tips, or special offers, etc. If you would prefer not to receive these messages, you may HYPERLINK "<https://www.mymeetings.com/emeet/remove.jsp>" unsubscribe now. Thank you.

VTC to Regions:

NRC HQ – Sharon Hudson 301-415-7322
Region I – Gina Matakis 610-337-5105
Region II – Pat Miles 404-562-4413
Region III – Pat Buckley 603-829-9657
Region IV - Lucy Owen 817-860-8227

NOTE: The VTC will also be used for the last 30 minutes for OCF0/OEDO to meet with budget contacts.

If you have any questions, please contact George Smolik.

Thank you,

Sharon M. Hudson
Administrative Assistant for the CFO and Deputy CFO
Office of the Chief Financial Officer
301-415-7322

AGENDA

When: Thursday, March 24, 2011 4:00 PM-5:30 PM Eastern Time.
Where: Commissioner's Hearing Room

~~*~*~*~*~*~*~*~*

A meeting has been scheduled for 3/24/11, 4:00pm-5:30pm, Commissioner's Hearing Room, with the CFO, EDO, DEDOs, Office Directors, and Regional Administrators to discuss the Commission's FY 2013 Performance Budget High-Level Planning Guidance and the CFO/EDO FY 2013 Budget Instructions.

Purpose: To review and discuss key aspects of the Commission's FY 2013 performance budget high-level planning guidance, as well as CFO/EDO expectations regarding the FY 2013 budget.

Outcome: (1) Understanding of the Commission's expectations to develop an essentially flat FY 2013 budget; and, (2) Understanding of CFO/EDO expectations that offices should look at resources holistically across program areas to ensure the highest priority items are adequately funded.

Process: The CFO and EDO will provide a brief overview of the: (1) overarching objectives contained in the Commission's FY 2013 performance budget high-level planning guidance; (2) key aspects of the Commission's guidance regarding the Nuclear Reactor Safety program, the Nuclear Materials and Waste Safety program, and the Corporate Support program; and, (3) the CFO/EDO expectations regarding the budget process as described in the CFO/EDO FY 2013 budget instructions.

4:00 PM – 5:00 PM

CFO, EDO, DEDOs, Office Directors, and Regional Administrators

- CFO/EDO overarching FY 2013 budget guidance.
- CFO/EDO overview of Commission's FY 2013 performance budget high-level planning guidance.
- CFO/EDO discuss expectations regarding the F 2013 budget process.
- Questions and Answers.

5:00 PM – 5:30 PM

OCFO, OEDO, and office budget staff.

- OCFO and OEDO staff discusses the CFO/EDO FY 2013 budget instructions.
- Questions and Answers.

A bridge line has been established for this meeting: ~~1-800-779-9286~~, passcode (b)(6)

Contact:
George Smolik, OCFO (301-415-7339)

From: Sheron, Brian on behalf of Ash, Darren
To: Valentin, Andrea; Arildsen, Jesse; ConferenceRoomO1784 Resource; Andersen, James; Landau, Mindy; Muessle, Mary; Garland, Stephanie; Bower, Phyllis; Greene, Kathryn; Jernell, Eleni; "Lesiak, Karen"; Malhotra, Shashi; Ronewicz, Lynn; Stewart, Sharon; Webber, Robert; Burns, Stephen; Mayberry, Theresa; Pulley, Deborah; Huth, Virginia; Sanchez, Alba
Cc: Borchardt, Bill; Taylor, Renee; Cienci, Sandra; Weber, Michael; Virgilio, Martin; Flory, Shirley; "Lyons, James"; Sheron, Brian; Veltri, Debra; Dean, Bill; Dieg, David; Salus, Amy; Sims, Carolyn; Wiggins, Jim; Brown, Milton; Oyer, Jim; Ellis, Mary; Hudson, Sharon; Belmore, Nancy; Decker, David; Powell, Amy; Schmidt, Rebecca; Akstulewicz, Brenda; Brenner, Elliot; Harrington, Holly; Hayden, Elizabeth; Davis, Kristin; Dingbaum, Stephen; Zane, Steven; Stetson, Kathleen; Cooper, Terri; Holley, David; Collins, Daniel; Baker, Pamela; Coleman, Judy; Holt, B.J.; Sotiropoulos, Dina; Hays, Myra; Clay, Earnestine; Daly, Jill
Subject: FW: OIG Entrance re: Evaluation of NRC's Contract Award Process
Attachments: 2011 Annual Audit Plan - Evaluation of NRC Contract Award Process.docx

The OIG Entrance Conference regarding the Evaluation of NRC's Contract Award Process is scheduled for Tuesday, March 29, 2011, 11:00 AM-11:30 AM for ½ hour in O-1784.

The evaluation's objective is to obtain an understanding of the NRC's contract award process and perform sufficient work to report on the agency's (1) compliance with applicable requirements (e.g., FAR and NRCAR requirements), and (2) identify any opportunities to improve the efficiency and effectiveness of the contract award process to include timeliness and internal controls. Please see the attached excerpt from the OIG's FY 2011 Annual Plan.

Recommended Attendance: DAO/TBPM/AO/DEDCM/ADM/OGC

Optional Attendance: EDO/DEDMRT/DEDR/RES/NSIR/CFO/OPA/OCA

cc: Jesse Arildsen, Kristin Davis, Stephen Dingbaum, Steven Zane, Kathleen Stetson, Terri Cooper, David Holley, Daniel Collins, Pamela Baker, Judy Coleman, B.J. Holt, Dina Sotiropoulos, Myra Hays, Earnestine Clay, Virginia Huth, Alba Sanchez, Jill Daly

Lead Office: ADM

Bridge Line Dial-in Number: 888-982-7409

Pass code: (b)(6)

VTC will not be provided.

POC: Jesse Arildsen x1785/Stephanie Garland x7443

Reminder: Please make sure that staff time spent supporting the OIG review is charged to T&L activity code ZG0025. For further guidance on charging time spent in support of OIG reviews, please see the memos from W. Travers to ODs and RAs (ML041240524) and to the non-EDO organizations (ML043210013), both dated May 14, 2004.

Stephanie Garland
Administrative Assistant to Darren Ash, DEDCM
Office of the Executive Director for Operations
O-17 H15
301-415-8704
stephanie.garland@nrc.gov

CH/428

Evaluation of NRC's Contract Award Process

DESCRIPTION AND JUSTIFICATION:

It is NRC's policy that the acquisition of supplies and services support the agency's mission; are planned, awarded, and administered efficiently and effectively; and are accomplished in accordance with applicable Federal statutes and procurement regulations. NRC acquisitions must adhere to the Federal Acquisition Regulation (FAR) and the NRC Acquisition Regulation (NRCAR). The Federal acquisition process is intended, among other objectives, to satisfy the customer in terms of cost, quality, and timeliness of the delivered product or service. The vision for the Federal acquisition process is to deliver on a timely basis the best value product or service to the customer, while maintaining the public's trust and fulfilling public policy objectives.

The Division of Contracts obligated approximately \$17.2 million and \$6.6 million during FY 2009 and FY 2010 (as of June 25, 2010), respectively, for new contract awards.

OBJECTIVES:

The evaluation objectives will be to obtain an understanding of the NRC's contract award process and perform sufficient work to report on the agency's (1) compliance with applicable requirements (e.g., FAR and NRCAR requirements), and (2) identify any opportunities to improve the efficiency and effectiveness of the contract award process to include timeliness and internal controls.

SCHEDULE:

Initiate in the 2nd quarter of FY 2011.

STRATEGIC GOAL 3:

Increase the economy, efficiency, and effectiveness with which NRC manages and exercises stewardship over its resources.

Strategy 3-1: Identify areas of corporate management risk within NRC and make recommendations, as warranted, for addressing them.

MANAGEMENT CHALLENGE 6:

Administration of all aspects of financial management and procurement.

From: Hanson, Mary E

To: (b)(6)

Cc:

Subject: NSTC Committee on Homeland and National Security

When: Friday, April 15, 2011 10:00 AM-12:00 PM (GMT-05:00) Eastern Time (US & Canada).

Where: White House Conf Center (Truman Room) - 728 Jackson Place NW

Note: The GMT offset above does not reflect daylight saving time adjustments.

~~*~*~*~*~*~*~*~*

This notice is going to CHNS members, their alternates and EAs. This meeting was announced in previous emails (most recent email below) and some agencies have already sent an rsvp. You are receiving this additional notice via Outlook in order to facilitate calendar management.

Sincerely, Mary Hanson - CHNS Executive Secretary

WHAT: Meeting of National Science and Technology Council (NSTC) Committee on Homeland and National Security (CHNS)

WHEN: Friday, April 15, 10 a.m. - Noon .

WHERE: White House Conference Center (Truman Room) - 728 Jackson Place, N.W., Washington, D.C.

DIRECTIONS: Located in the rear of the NEOB and in front of the LaFayette Square Park—directly north of the White House. (Drop-off location: intersection of H St. and Connecticut/Jackson Place. After exiting the car, walk toward White House ½ block; see 728 Jackson Place on right.)

BACKGROUND: This is the 3rd meeting of this committee this fiscal year. Minutes are available for the earlier meetings on October 22, 2010 and January 25, 2011 (see the MAX pages for NSTC CHNS, under HYPERLINK

"https://max.omb.gov/community/display/OSTP/CHNS+++Documentation+Archive" "Document Archives" or request them from Mary Hanson, HYPERLINK "mailto:mary.hanson@dhs.gov" mary.hanson@dhs.gov)

From: Hanson, Mary E HYPERLINK "mailto:[mailto:Mary.Hanson@dhs.gov]" [mailto:Mary.Hanson@dhs.gov]

Sent: Wednesday, March 02, 2011 1:06 PM

To: Hanson, Mary E

Subject: NSTC CHNS: 1 action (review requested by 4APR), 2 reminders (nominee requested, meeting scheduled)

Importance: High

Dear NSTC CHNS Members, one action and two reminders:

1. (ACTION) Review of draft R&D plan for foreign animal disease threats: Please review the attached draft R&D plan for 2012-2016 from the Subcommittee on Foreign Animal Disease Threats (FADT), and respond via the attached concurrence sheet. This is the second five-year plan produced by this subcommittee. As you may know, domestic agriculture and food play a critical role in the U.S. economy; the food and agriculture sector alone accounted for 4.6 percent of GDP in 2009. A domestic outbreak of a foreign animal disease (or rumor of one) could have significant economic consequences as a result of lost export markets and/or reduced consumer demand. This plan represents interagency consensus on how to better protect the U.S. agriculture infrastructure against the threats posed by the natural or intentional introduction of high consequence foreign animal or zoonotic diseases. Action: Return the completed concurrence sheet to me (HYPERLINK "mailto:mary.hanson@dhs.gov" mary.hanson@dhs.gov) no later than Monday, April 4. Non-response will be considered concurrence. (This document is provided in Word format to facilitate your review. We will distribute a graphically-designed final version for your records) If you have questions about the clearance process or the content, please contact me or the FADT Subcommittee Executive Secretary, Anne Marie Zaudtke (HYPERLINK "mailto:anne.zaudtke@associates.dhs.gov" anne.zaudtke@associates.dhs.gov).

2. (REMINDER) Your nominee requested for Infrastructure Subcommittee: As mentioned in my email of Dec. 14, and the meeting of Jan. 25, this subcommittee is reconstituting itself to focus on all-hazards protection and resiliency in an integrated approach to infrastructure goals. Action: Please identify your representative to this subcommittee to Paul Domich (HYPERLINK "mailto:domich@cip-consulting.com" domich@cip-consulting.com) now. (The deadline has already passed.)

3. (REMINDER) Next CHNS Meeting: As mentioned in my email of Feb. 22, the next meeting of the Committee on Homeland and National Security (CHNS) will take place on Friday, April 15 - 10 a.m. to noon in the White House Conference Center (Truman Room). More details to follow.

CH/429

Sincerely, Mary Hanson

(b)(6)

FY12 budget presentation: <http://www.whitehouse.gov/sites/default/files/microsites/ostp/FY12-slides.pdf>

Mary E. Hanson
Executive Secretary
Committee on Homeland and National Security (CHNS)
National Science & Technology Council (NSTC)
HYPERLINK "mailto:mary.hanson@dhs.gov" mary.hanson@dhs.gov, 202-254-5866

From: [Sheron, Brian](#)
To: [Weber, Michael](#); [Virgilio, Martin](#); [Evans, Michele](#)
Subject: FW: Fukushima No. 1
Date: Thursday, March 17, 2011 10:21:00 AM
Attachments: [3-16-11-Fukushima.ppt](#)

Might be helpful.

From: Gibson, Kathy
Sent: Thursday, March 17, 2011 8:48 AM
To: Sheron, Brian; Uhle, Jennifer
Subject: Fw: Fukushima No. 1

From: Lee, Richard
To: Gibson, Kathy; Scott, Michael
Sent: Thu Mar 17 08:39:25 2011
Subject: Fukushima No. 1

Kathy & Mike:

Attached is VGs received from Prof. Mike Corradini yesterday.

Richard

CH/430

Fukushima Daiichi Nuclear Station

- Six BWR units at the Fukushima Nuclear Station:
 - Unit 1: 439 MWe BWR, 1971 (unit was in operation prior to event)
 - Unit 2: 760 MWe BWR, 1974 (unit was in operation prior to event)
 - Unit 3: 760 MWe BWR, 1976 (unit was in operation prior to event)
 - Unit 4: 760 MWe BWR, 1978 (unit was in outage prior to event)
 - Unit 5: 760 MWe BWR, 1978 (unit was in outage prior to event)
 - Unit 6: 1067 MWe BWR, 1979 (unit was in outage prior to event)

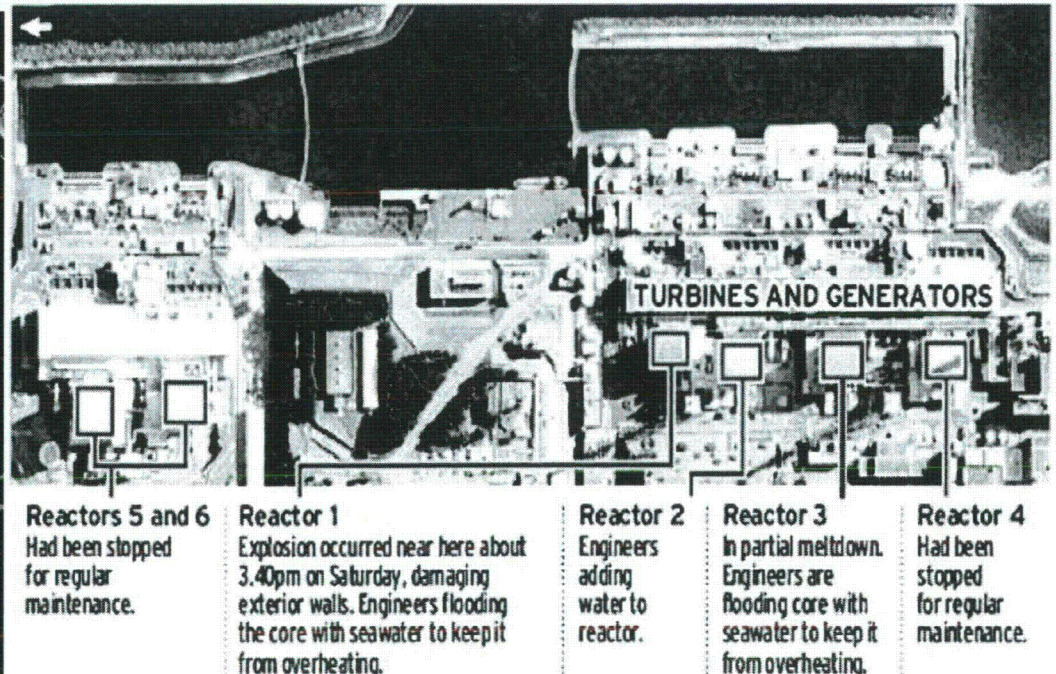
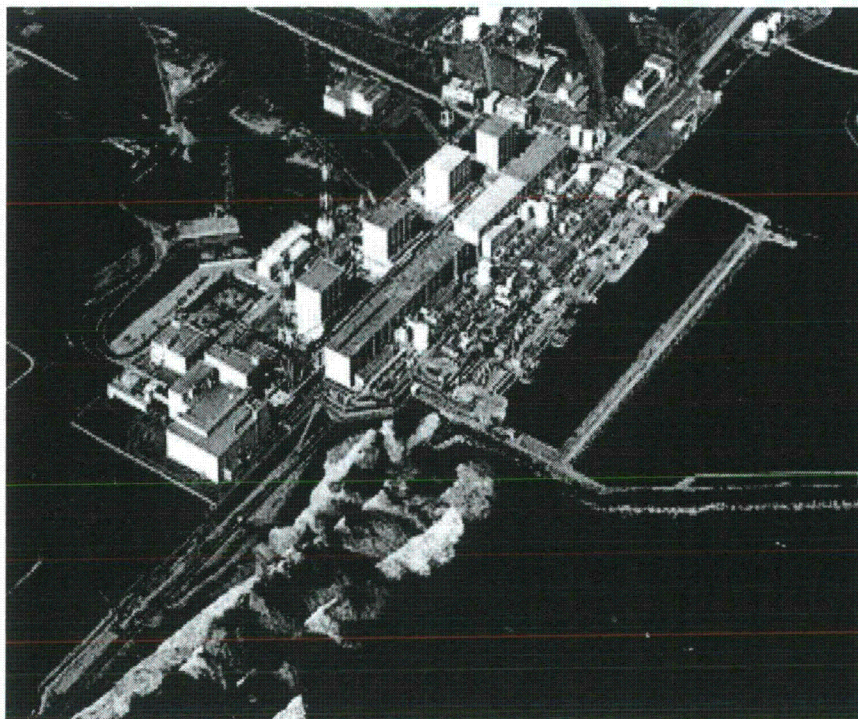

SOURCE: NYT; TOKYO ELECTRIC POWER; SATELLITE IMAGE BY DIGITAL GLOBE VIA GOOGLE EARTH.

Fukushima Daiichi Unit 1

- Typical BWR 3 and 4 Reactor Design
- Some similarities to Duane Arnold Power Plant in Iowa

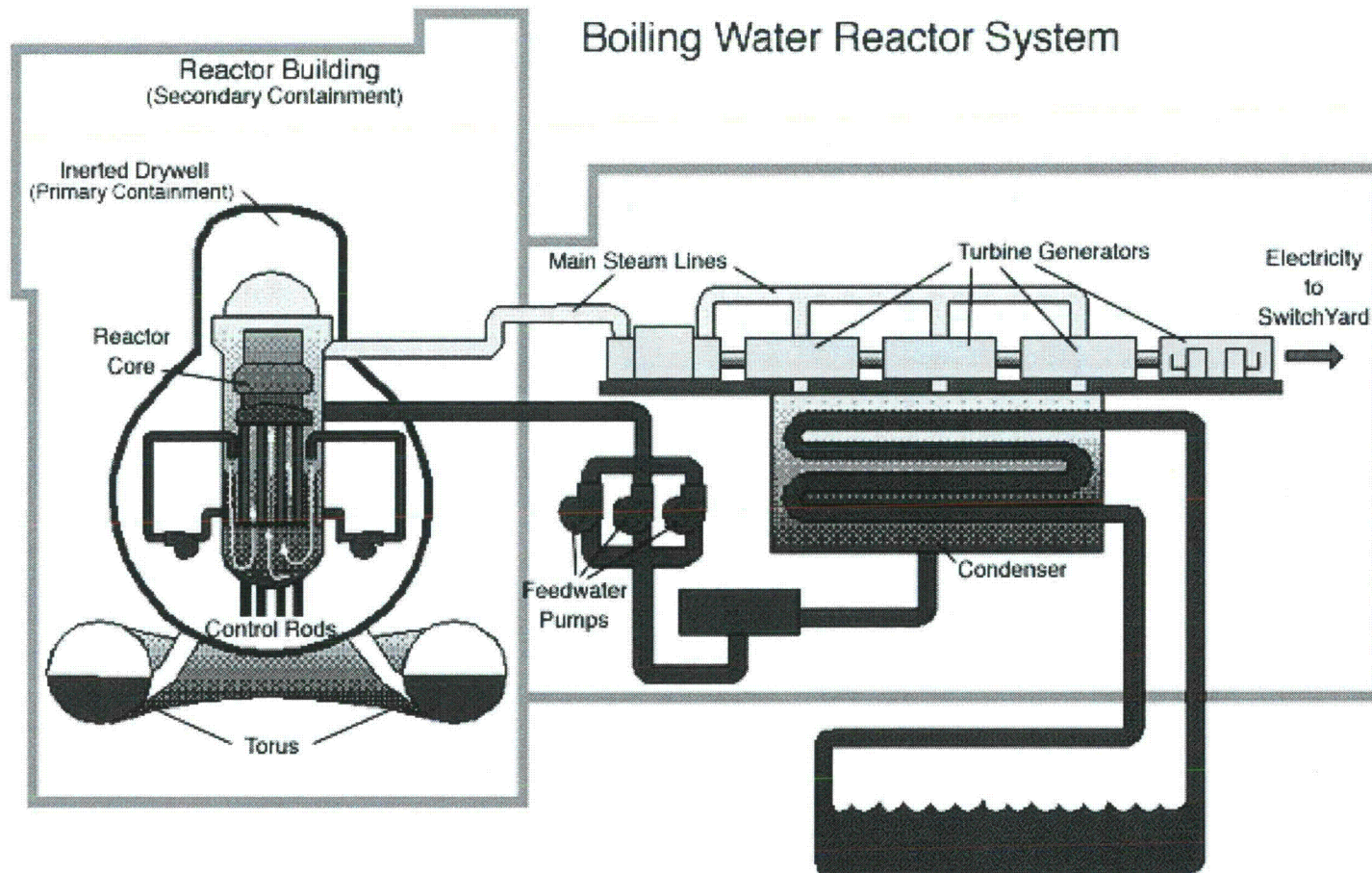

Fukushima Daiichi Unit 1

■ Mechanism of Boiling Water Reactor Power Station

Primary Containment Vessel (Dry Well)

It would confine radioactive substances discharged from the reactor facilities if some pipes were broken by accident.

Reactor Pressure Vessel

It is made of 12cm thick steel and contains fuel, control rods, jet pumps, steam-water separator and steam dryer.

Primary Recirculation pump

It circulates water in the reactor pressure vessel and changes reactor power by changing water quantity.

Cleanup Water System

It maintains the purity of the water circulating through the reactor.

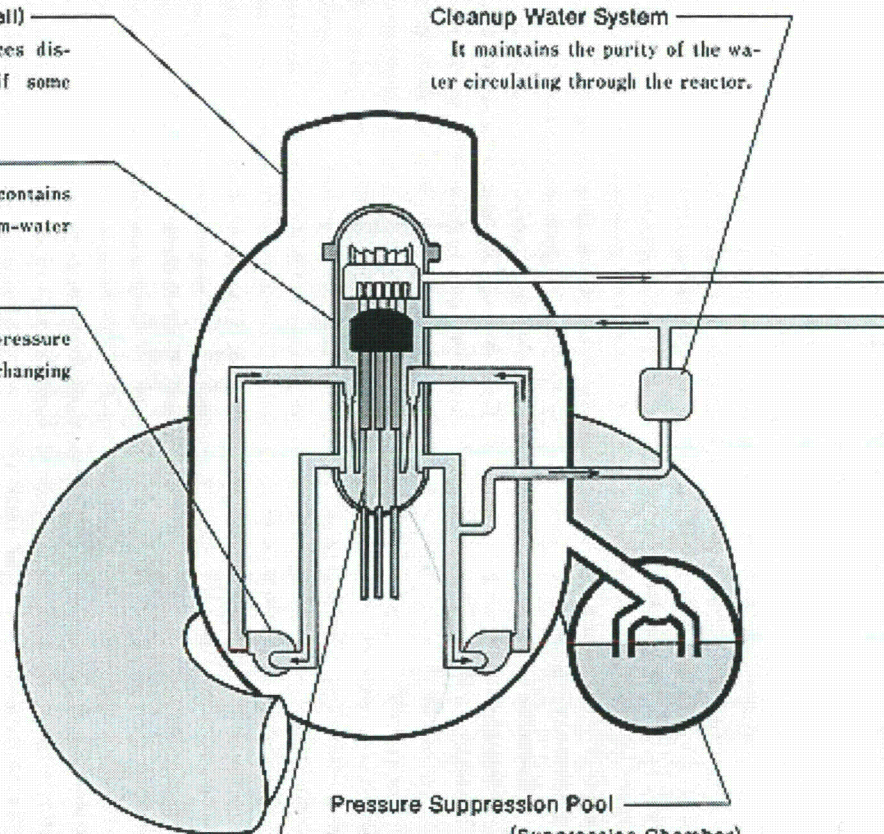

Pressure Suppression Pool

(Suppression Chamber)

It always contains water. Should pipes in the primary containment vessel ever break, leaked steam would be conducted into the pool, where it would be cooled down and condensed with a large amount of water to suppress any rise in pressure in the primary containment vessel.

Control Rods

They are used to start and stop the reactor and to change reactor power (amount of nuclear fission) by individually inserting and extracting from the bottom of the reactor.

Fukushima Daiichi Unit 1

Secondary containment:
Area of explosion at
Fukushima Daiichi 1

Primary containment:
Remains intact and safe

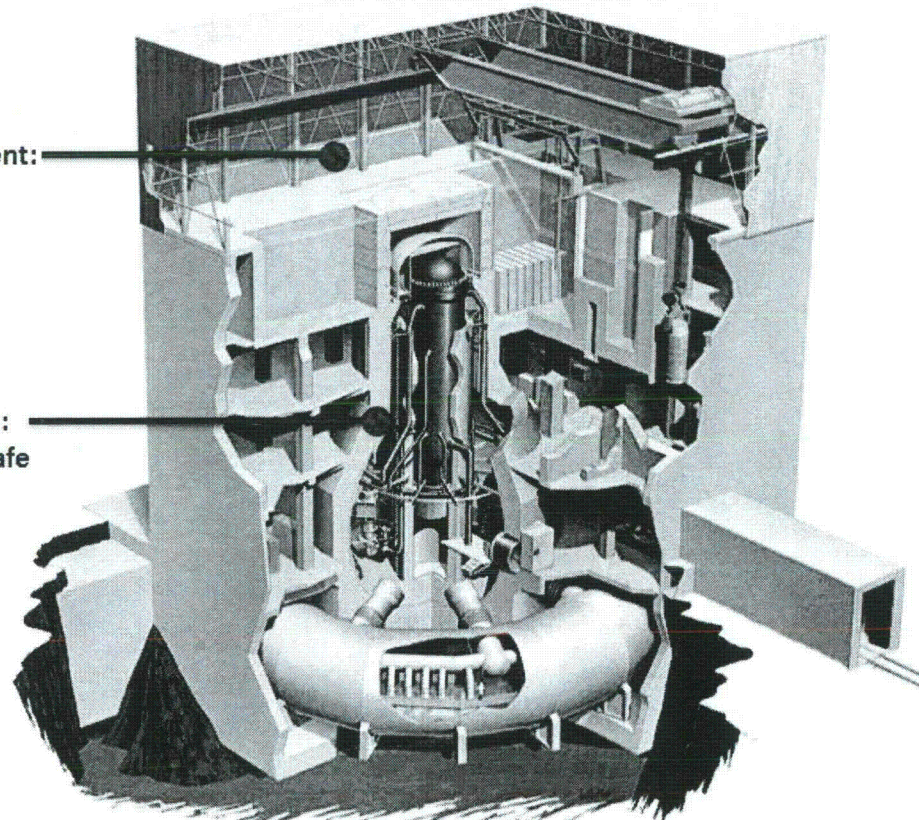

Boiling Water Reactor Design

Event Initiation

- The Fukushima nuclear facilities were damaged in a magnitude 9 earthquake on March 11 (Japan time), centered offshore of the Sendai region, which contains the capital Tokyo.
 - Plant designed for magnitude 8.2 earthquake. An 9 magnitude quake is much greater in magnitude.
- Serious secondary effects followed including a significantly larger tsunami, significant aftershocks and a major fire at a fossil fuel installation.



By Janet Loehrke, USA TODAY

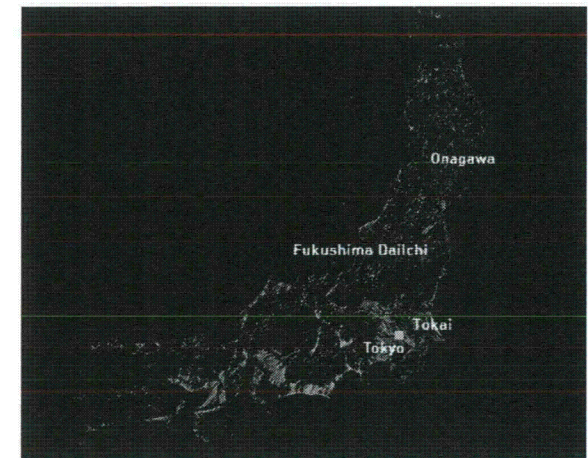
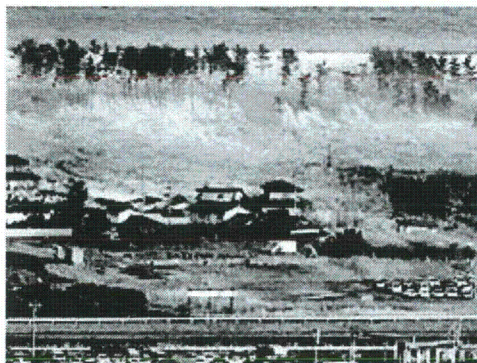

Initial Response

- Nuclear reactors were shutdown automatically. Within seconds the control rods were inserted into core and nuclear chain reaction stopped.
- Cooling systems were placed in operation to remove the residual heat. The residual heat load is about 3% of the heat load under normal operating conditions decreasing to much less than 1% after days.
- Earthquake resulted in the loss of offsite power which is the normal supply to a plant when it is shutdown.
- Emergency Diesel Generators started and powered station emergency cooling systems.
- One hour later, the station was struck by the tsunami. The tsunami was larger than what the plant was designed for (20ft waves). The tsunami took out all multiple sets of the backup Emergency Diesel generators and likely damaged the service water pumps which provide cooling from the sea.
- Reactor operators were able to utilize emergency battery power to provide power for cooling the core for 8 hours.
- Operators followed abnormal operating procedures and emergency operating procedures.

Loss of Makeup

- Offsite power could not be restored and delays occurred obtaining and connecting portable generators.
- After the batteries ran out, residual heat could not be carried away any more.
- Reactor temperatures increased and water levels in the reactor decreased, eventually uncovering and overheating the core.
- Hydrogen was produced from metal-clad/water reactions in the reactor.
- Operators vented the reactor to relieve steam pressure and energy (and hydrogen) was released into the primary containment (drywell) causing primary containment temperatures and pressures to increase.
- Operators took actions to vent the primary containment to control containment pressure and hydrogen levels through the wetwell. Required to protect the primary containment from failure.
- Primary Containment Venting is through a filtered path that travels through duct work in the secondary containment to an elevated release point on the refuel floor (on top of the reactor building).
- A hydrogen detonation subsequently occurred while venting the reactor building above the drywell. Occurred shortly following an aftershock at the station. Spark likely ignited hydrogen.

Core Damage Sequence

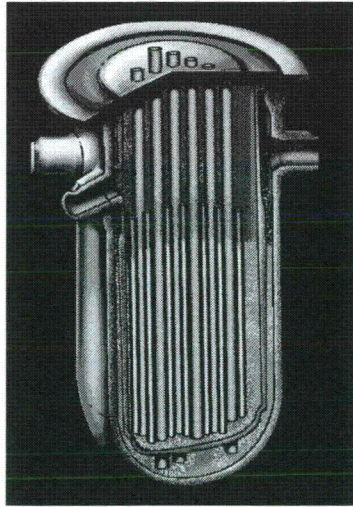

Core Uncovered

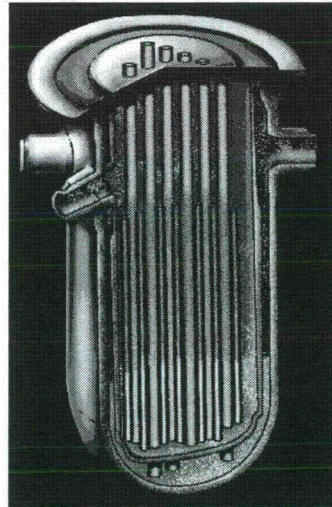

Fuel Overheating

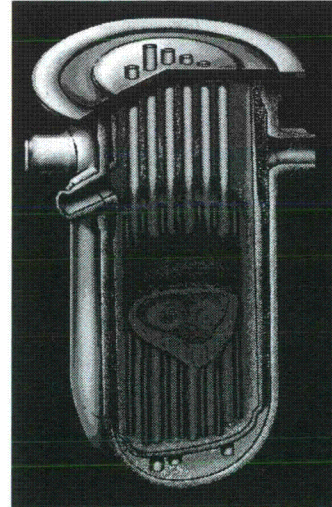

Fuel melting - Core Damaged



Core Damaged but retained in vessel



Core Melt-through
Some portions of core melt into lower RPV head

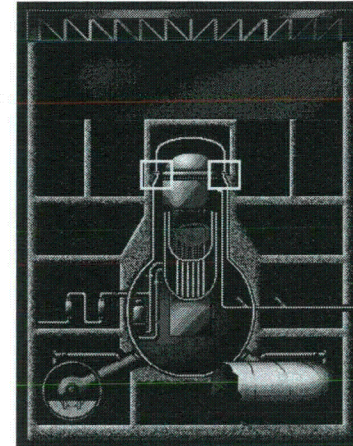

Containment pressurizes.
Leakage possible at drywell head



Releases of hydrogen into secondary containment

Hydrogen Detonation at Unit 1

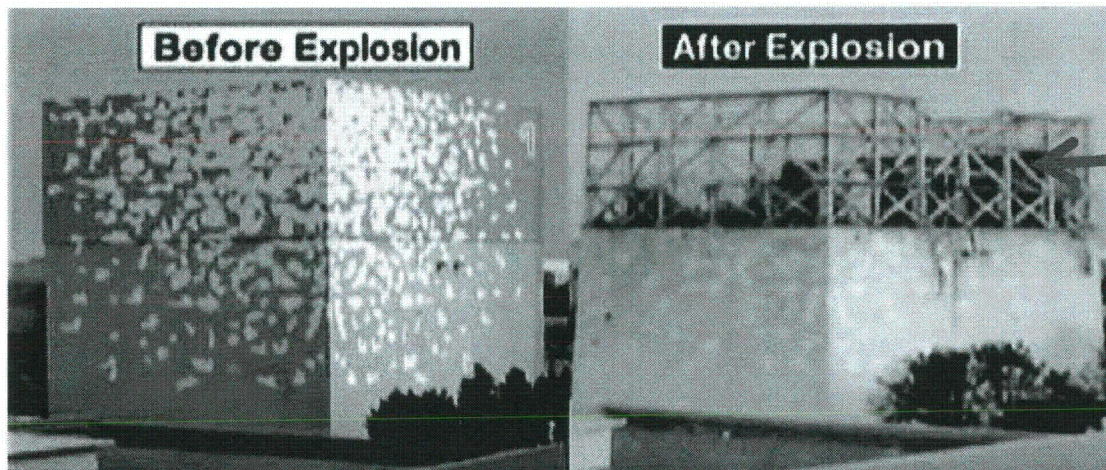

Reactor Building

Mitigating Actions

- The station was able to deploy portable power generators and utilize portable fire pumps to inject sea water into the reactor and primary containment.
- Station operators began flooding the reactor vessel
- Reports suggest that pumps were also injecting water into the containment – but it's unclear
- Boric acid was added to the seawater used for injection. Boric acid is “liquid control rod” . The boron captures neutrons and speeds up the cooling down of the core. Boron also reduces the release of iodine by buffering the containment water pH.

Containment Flooding Effects

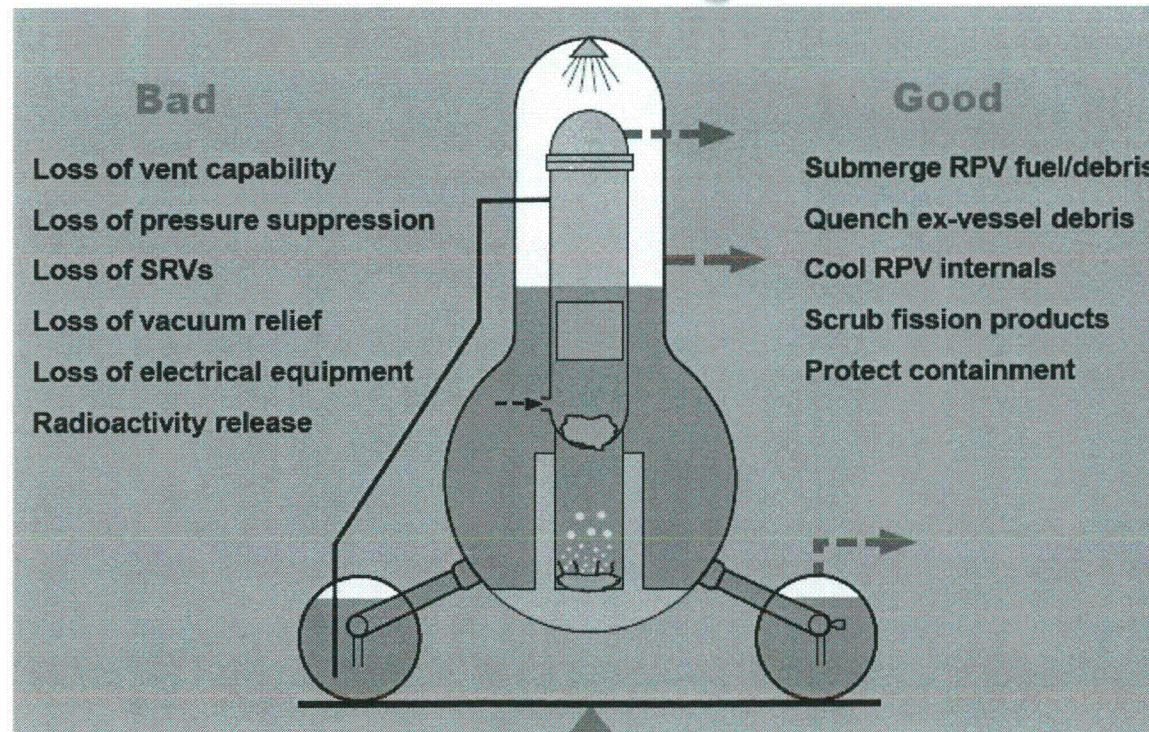

Emergency Response

- Equivalent of General Emergency declared to the initial events in Unit 1 on Friday.
- Evacuation of public performed within 20 km (13 miles) of plant; approximately 200,000 people evacuated and sheltering in place within 30km (20 miles).
- Similar hydrogen detonation subsequently occurred at Unit 3 late on Sunday, March 14th (Japan time). Primary containment appears to remain intact at Unit' s 1 and 3 throughout the accident. There was considerable damage to the secondary containment (reactor building). A similar scenario occurred in Unit 2 on Tuesday.
- Recorded radiation levels have spiked after each event (above) at the Fukushima Daiichi site (140-800mrem/hr). Radiation levels were subsequently reduced to a few millirem after the after cooling was restored. The NRC' s radiation dose limit for the public is 100 millirem per year and natural background is about 300 mrem per year.
- Several injured workers were reported at the plant with radiation exposure of ~10rem.
- Authorities distributed Potassium-iodide tablets to protect the public from potential health effects of radioactive isotopes of iodine that could potentially be released. This is quickly taken up by the body and its presence prevents the take-up of iodine-131 should people be exposed to it.
- Over 300 after shocks have occurred and continue to challenge station response.
- THE SITUATION FOR SPENT FUEL POOLS HAS NOT BEEN ADDRESSED HERE