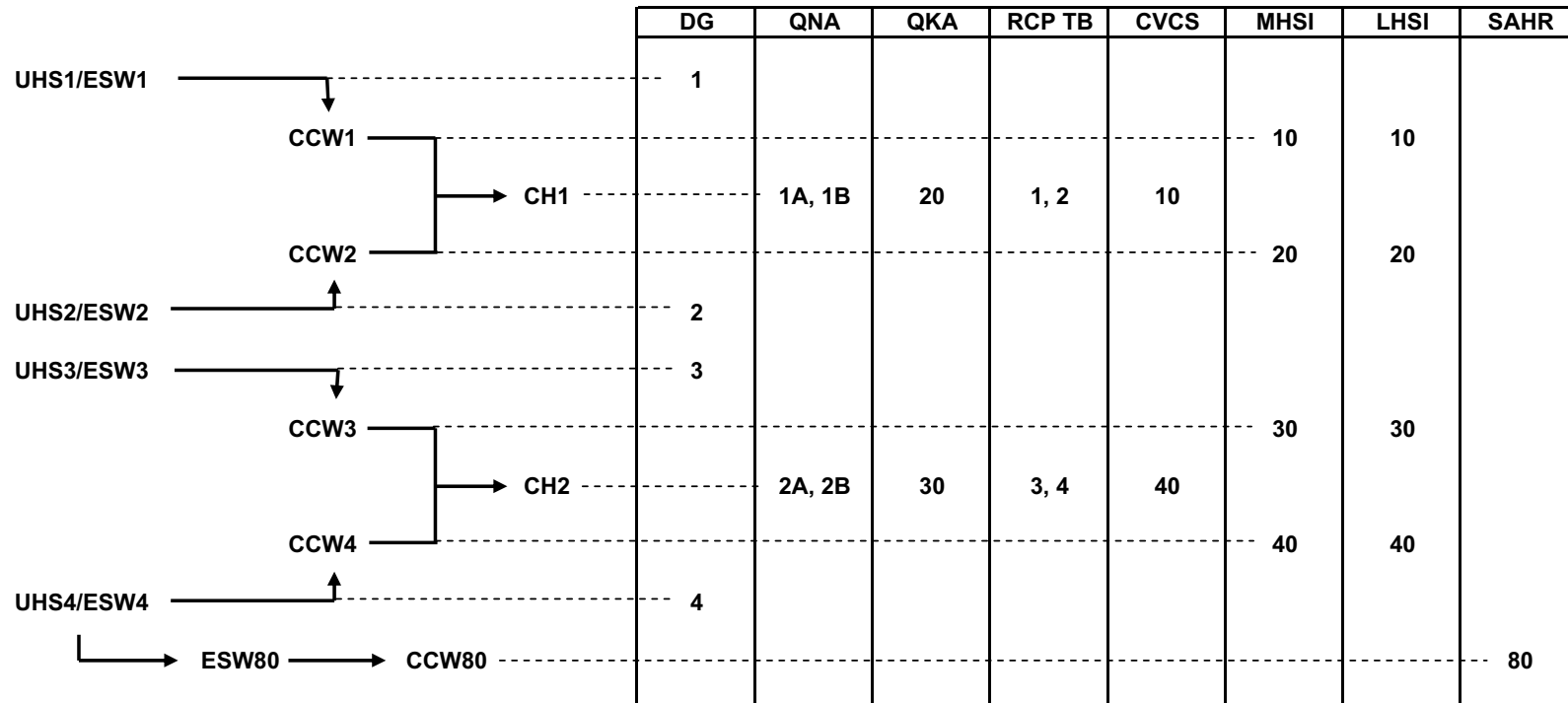
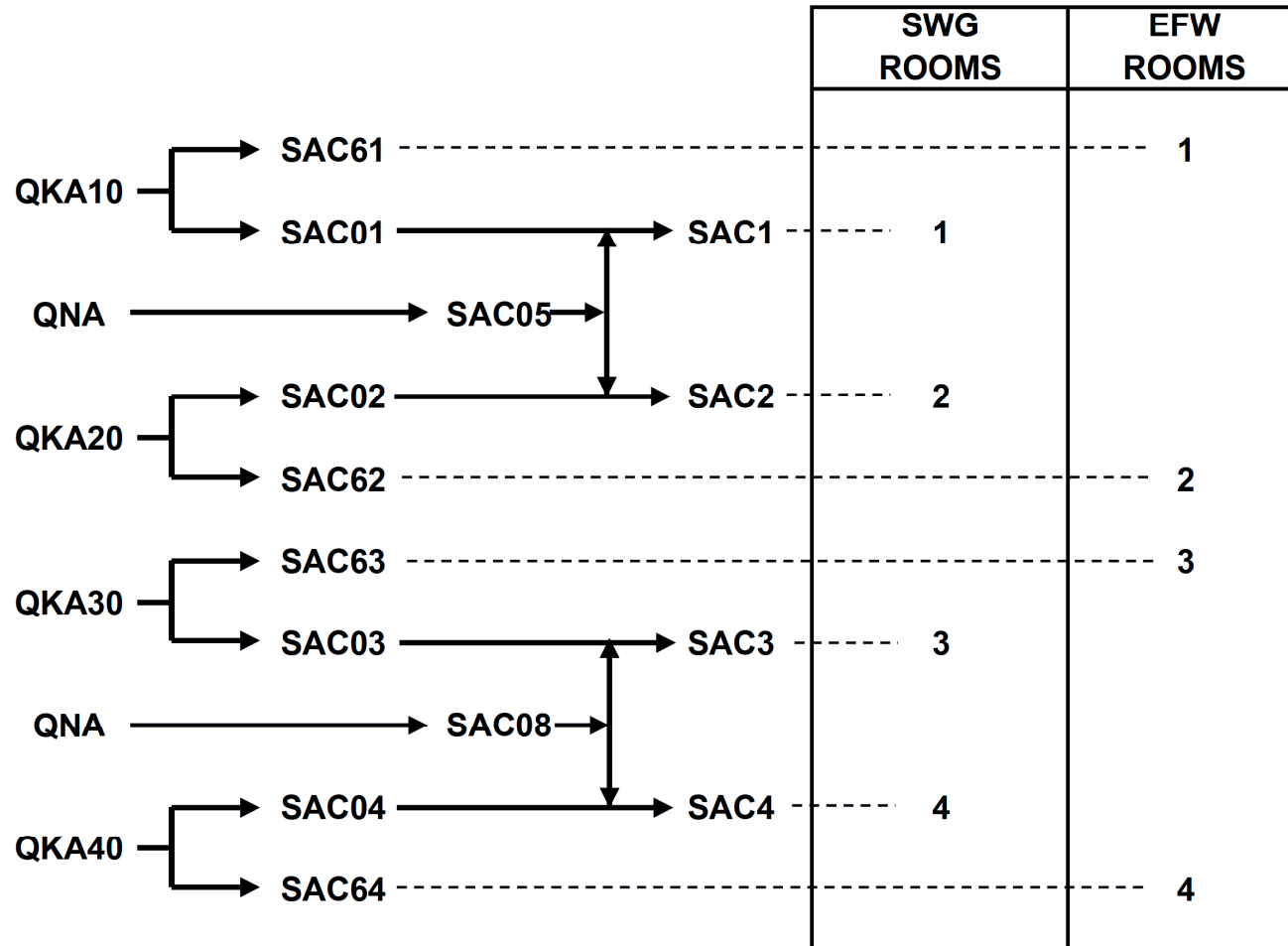

Figure 19.1-1—Cooling Water Dependencies Modeled in the U.S. EPR PRA



EPR6000 T2

Figure 19.1-2—Ventilation Dependencies Modeled in the U.S. EPR PRA



REV 005  
EPR6005 T2

Figure 19.1-3—Selected Dependencies on Electric Power Modeled in the U.S. EPR PRA

		Electrical Dependency															
		RCP Seals				MSRIV				PSRV			PDSV		CCW Switchover		
		RCP1	RCP2	RCP3	RCP4	1	2	3	4	1	2	3	1	4	CH1	CH2	
1E 480 V	31BRA					■	■	■	■	■					■		■
	32BRA					■	■	■	■	■					■		■
	33BRA					■	■	■	■	■	■	■				■	■
	34BRA					■	■	■	■	■	■					■	■
Non 1E 480 V	31BRB	■													■	■	
	32BRB		■														
	33BRB			■													
	34BRB				■										■	■	
1E 24 V	BRW10 / BUW11					■	■	■	■								
	BRW32 / BUW33					■	■	■	■								
	BRW52 / BUW53					■	■	■	■								
	BRW70 / BUW71					■	■	■	■								
1E 24 V	BRW12 / BUW13														■		■
	BRW30 / BUW31															■	■
	BRW50 / BUW51														■		■
	BRW72 / BUW73														■		■

Note: The non 1E buses in the table are backed by 12-hour batteries; the 1E buses in the table are backed by 2-hr batteries.

REV 005  
EPR6010 T2

**Figure 19.1-4—U.S. EPR Initiating Events Contributions - Level 1 Internal Event**

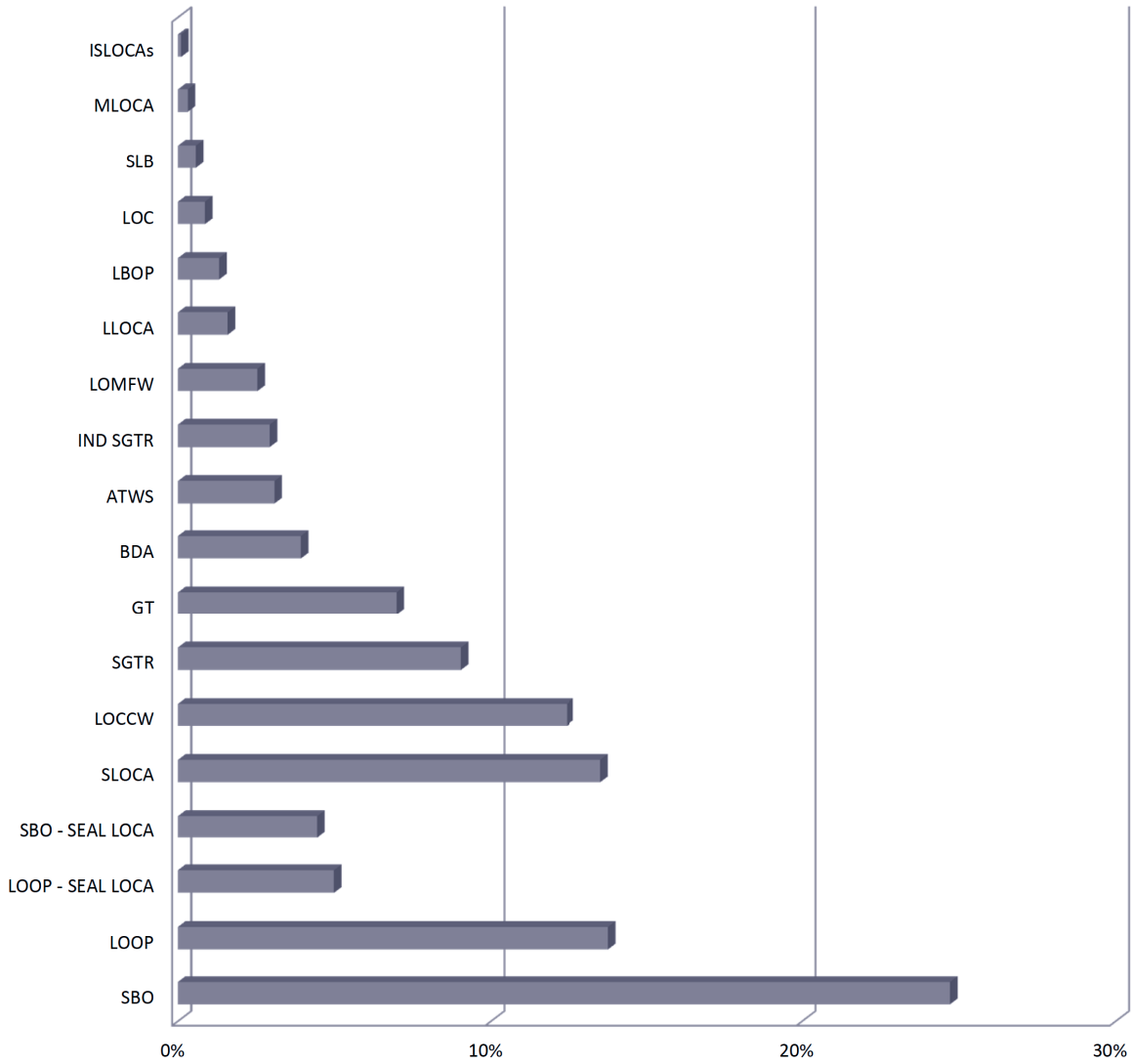

REV 005  
EPR6015 T2

Figure 19.1-5—U.S. EPR Level 1 Internal Events Uncertainty Analysis Results - Cumulative Distributions for Internal Events CDF

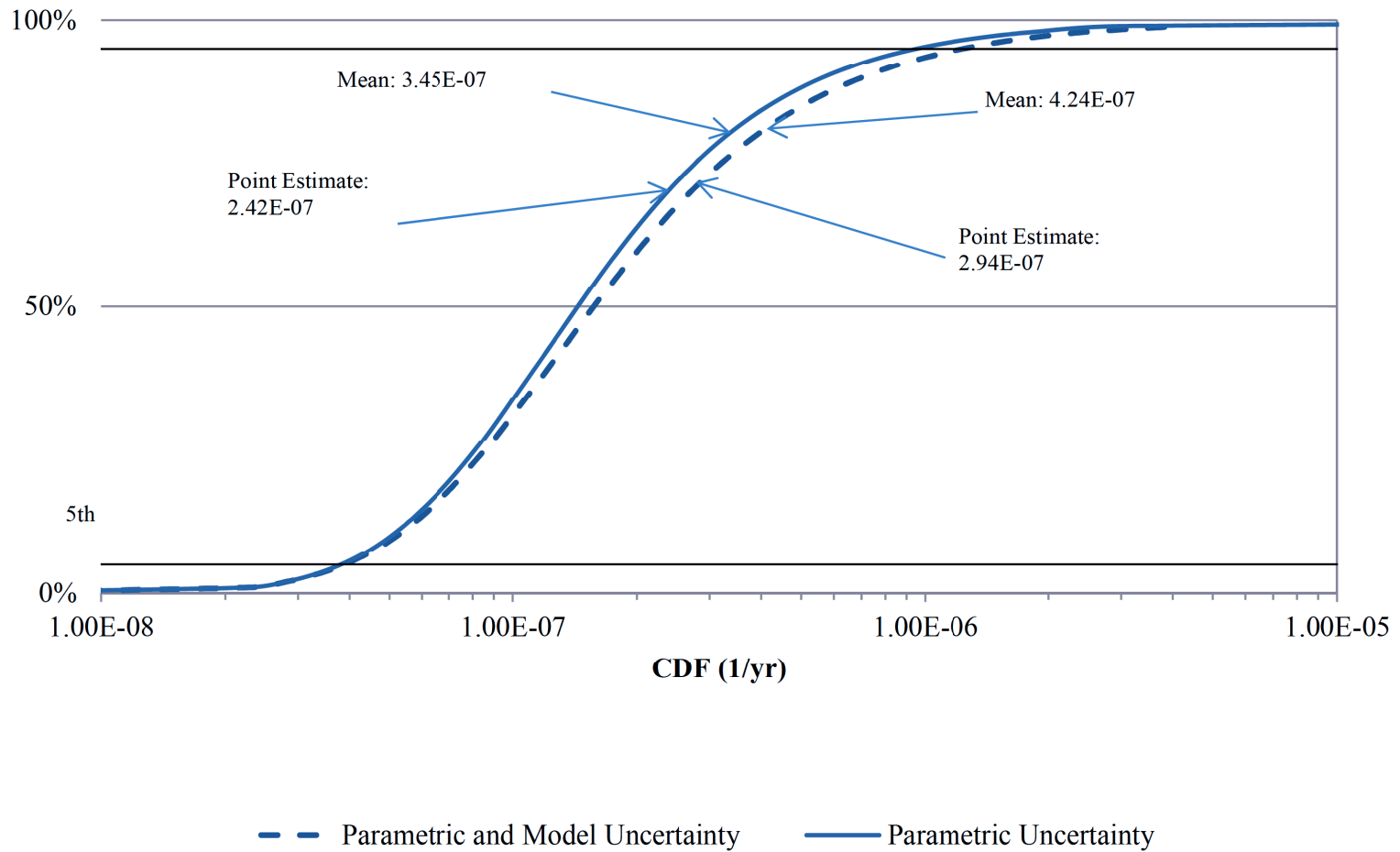

REV 005  
EPR6020 T2

Figure 19.1-6—Natural Circulation Flowpaths in the Primary System

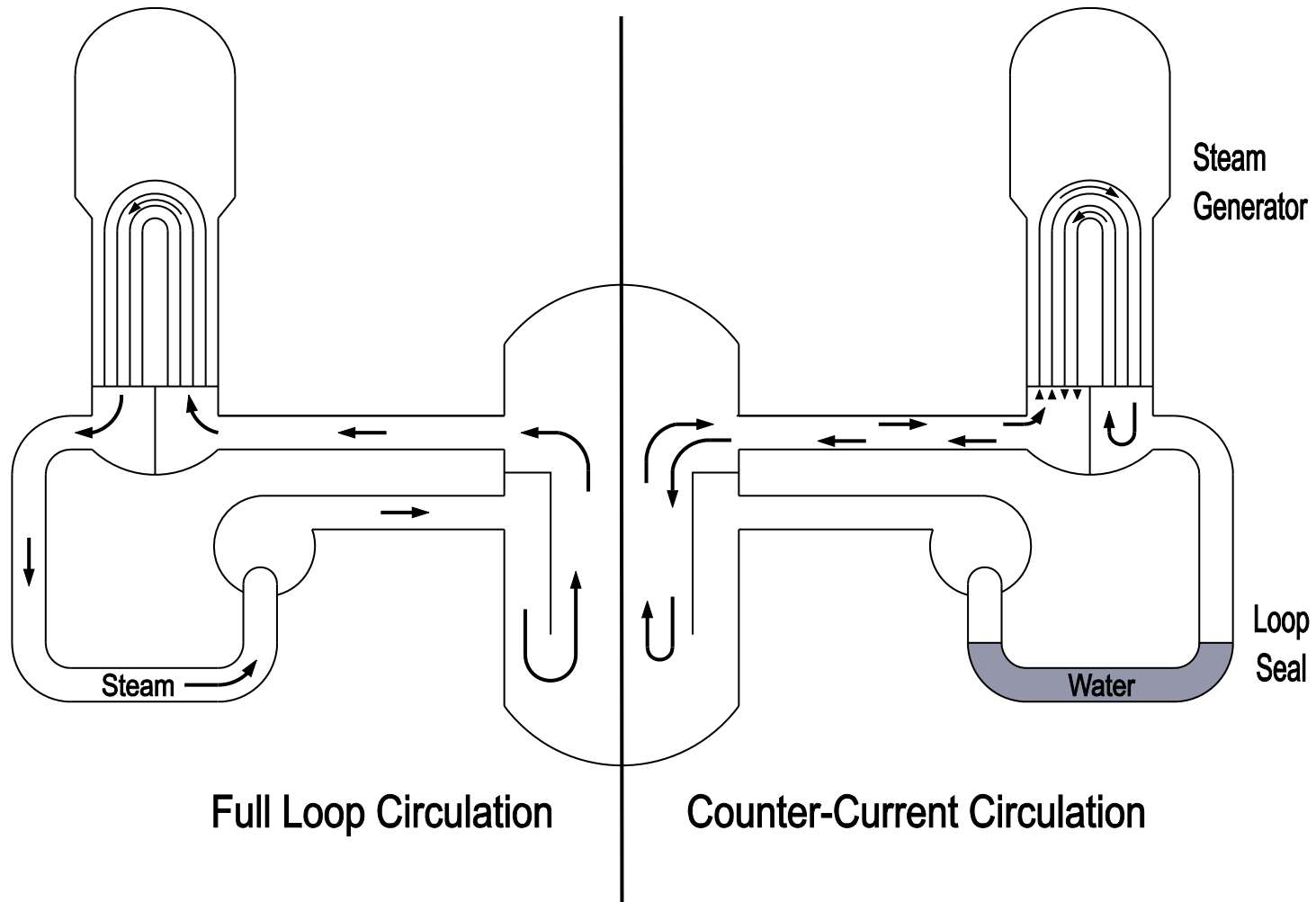

EPR6025 T2

Figure 19.1-7—Decomposition Event Tree for Long Term Challenges

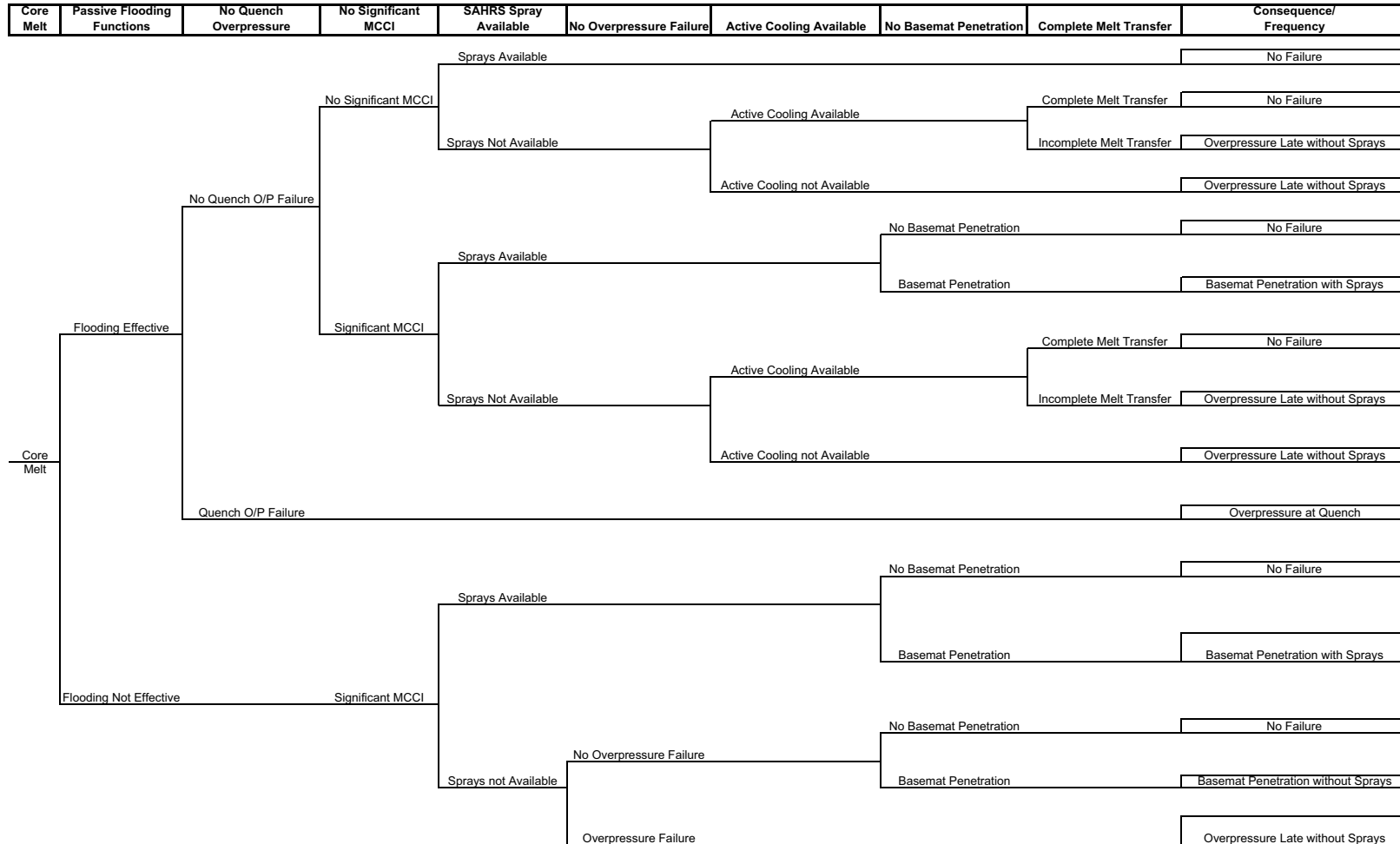

EPR6027 T2

Figure 19.1-8—Containment Composite Fragility Curve at 309°F

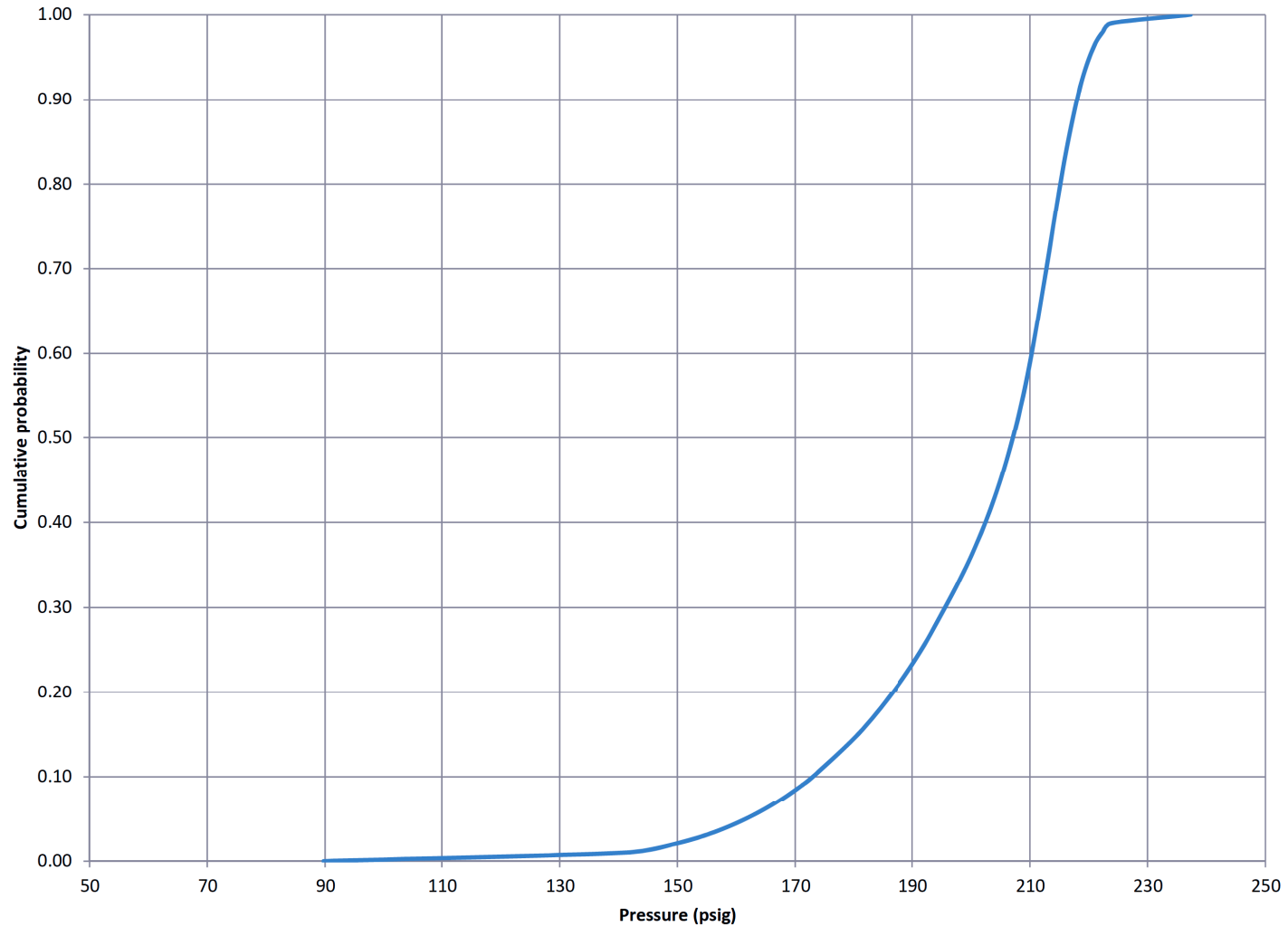

REV 005  
EPR6030 T2



Figure 19.1-9—U.S. EPR Level 2 Internal Events Uncertainty Analysis Results - Cumulative Distribution for Internal Events LRF

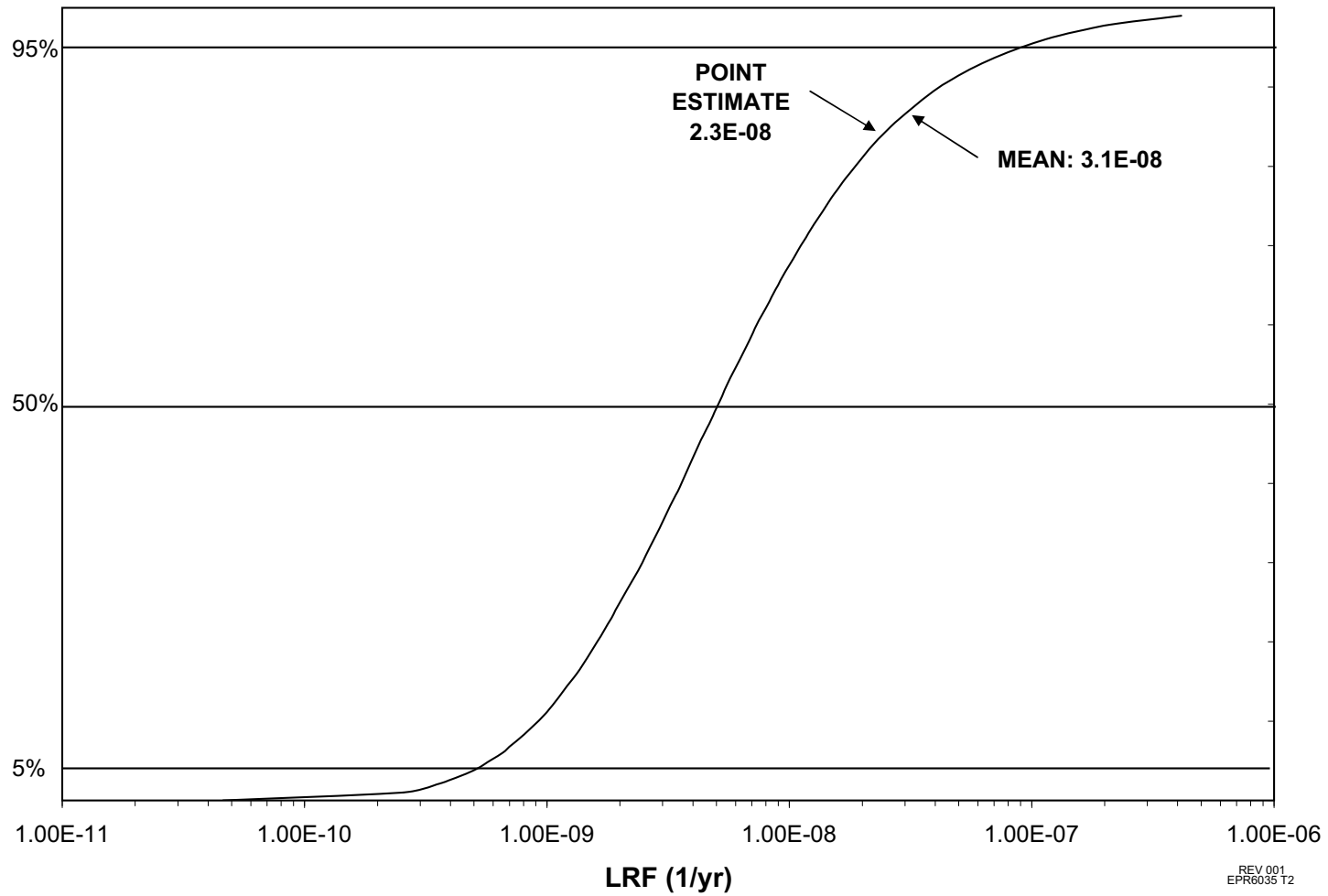
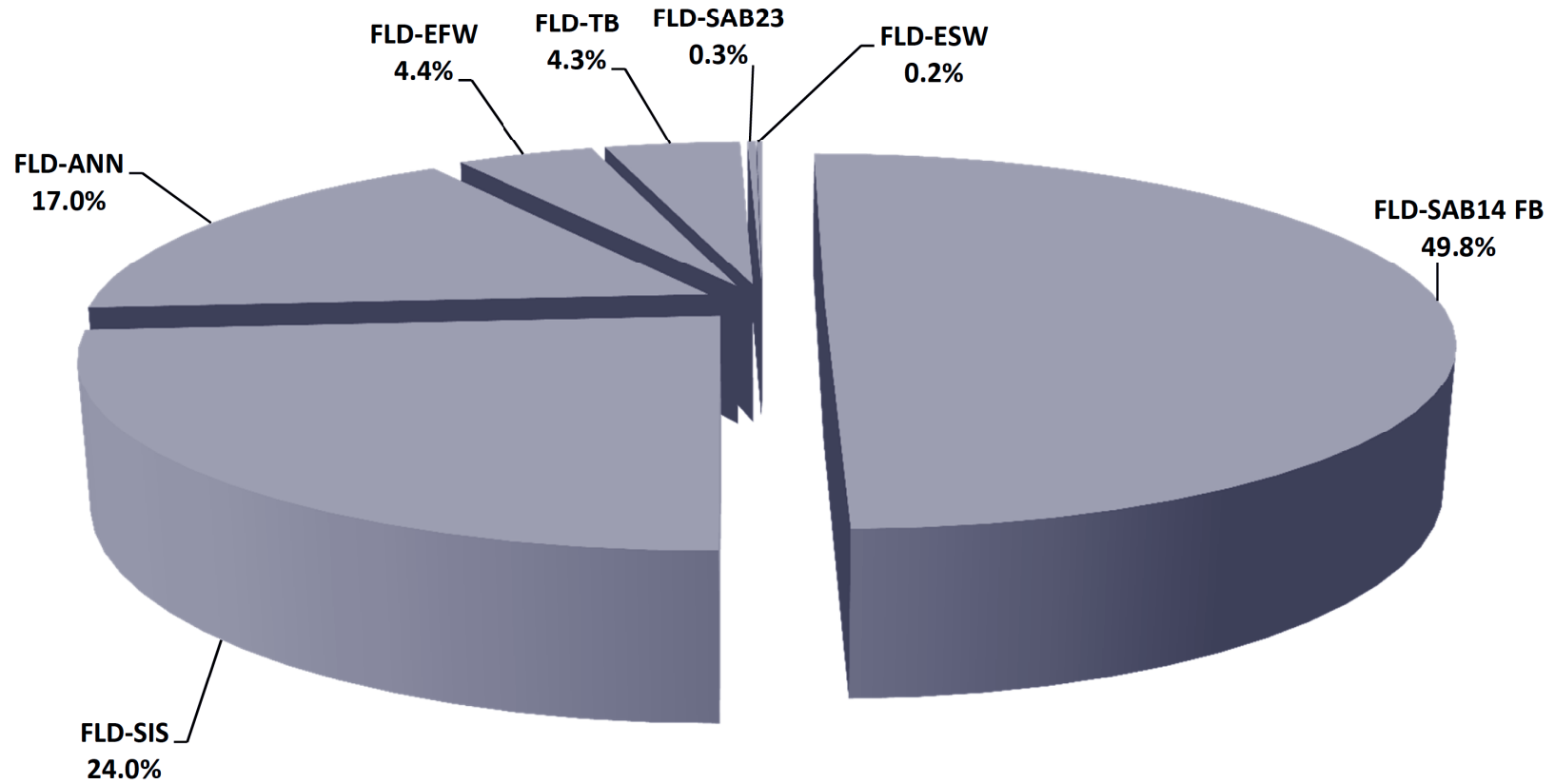

Figure 19.1-10—Deleted)

Figure 19.1-11—Deleted

Figure 19.1-12—U.S. EPR Initiating Event Contributions - Level 1 Flooding



**Flood CDF: 6.1E-08/yr**

REV 005  
EPR6055 T2

Figure 19.1-13—U.S. EPR Level 1 Internal Flood Events Uncertainty Analysis Results - Cumulative Distribution for Flood Events CDF

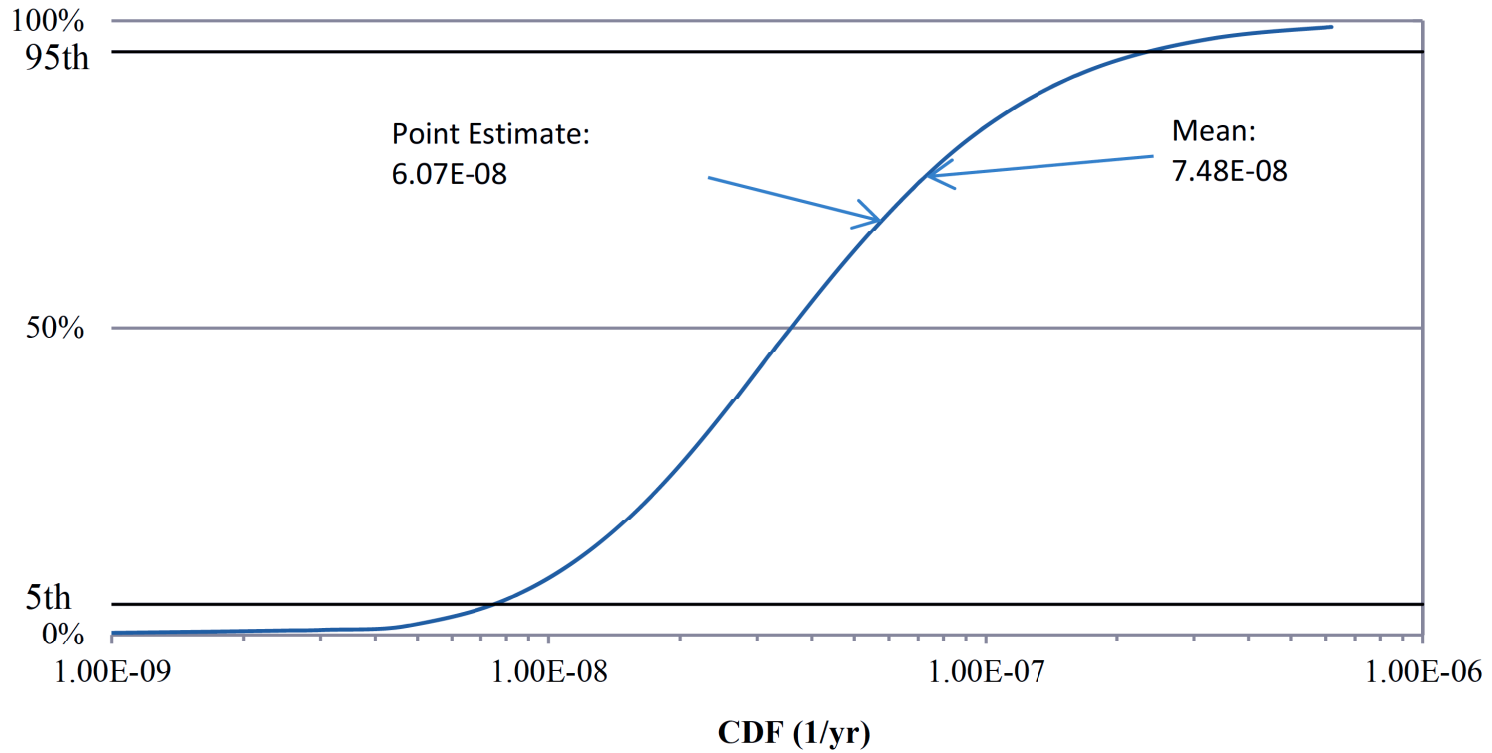

REV 005  
EPR6060 T2

Figure 19.1-14—U.S. EPR Level 2 Flood Events Uncertainty Analysis Results - Cumulative Distribution for Flood Events LRF

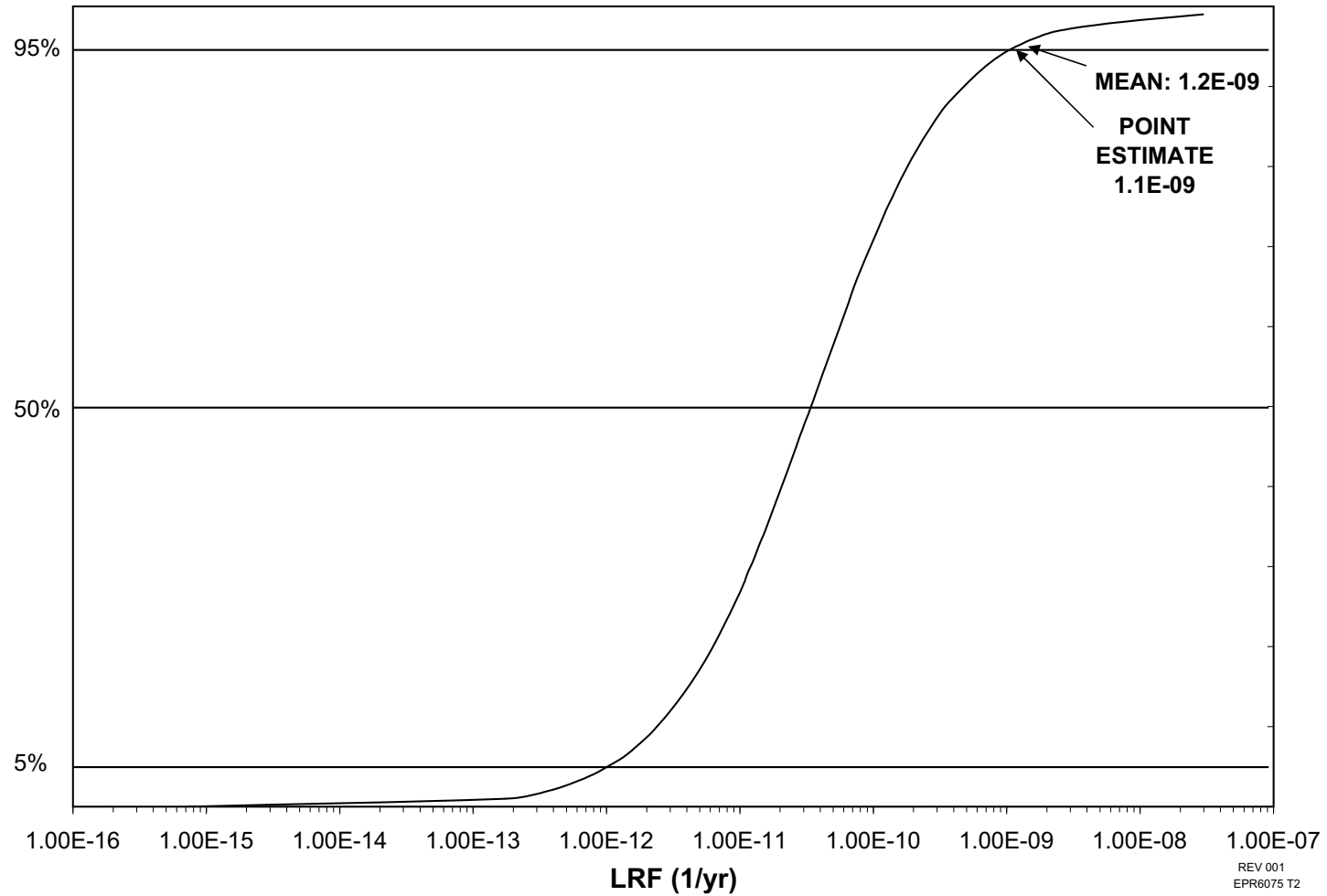
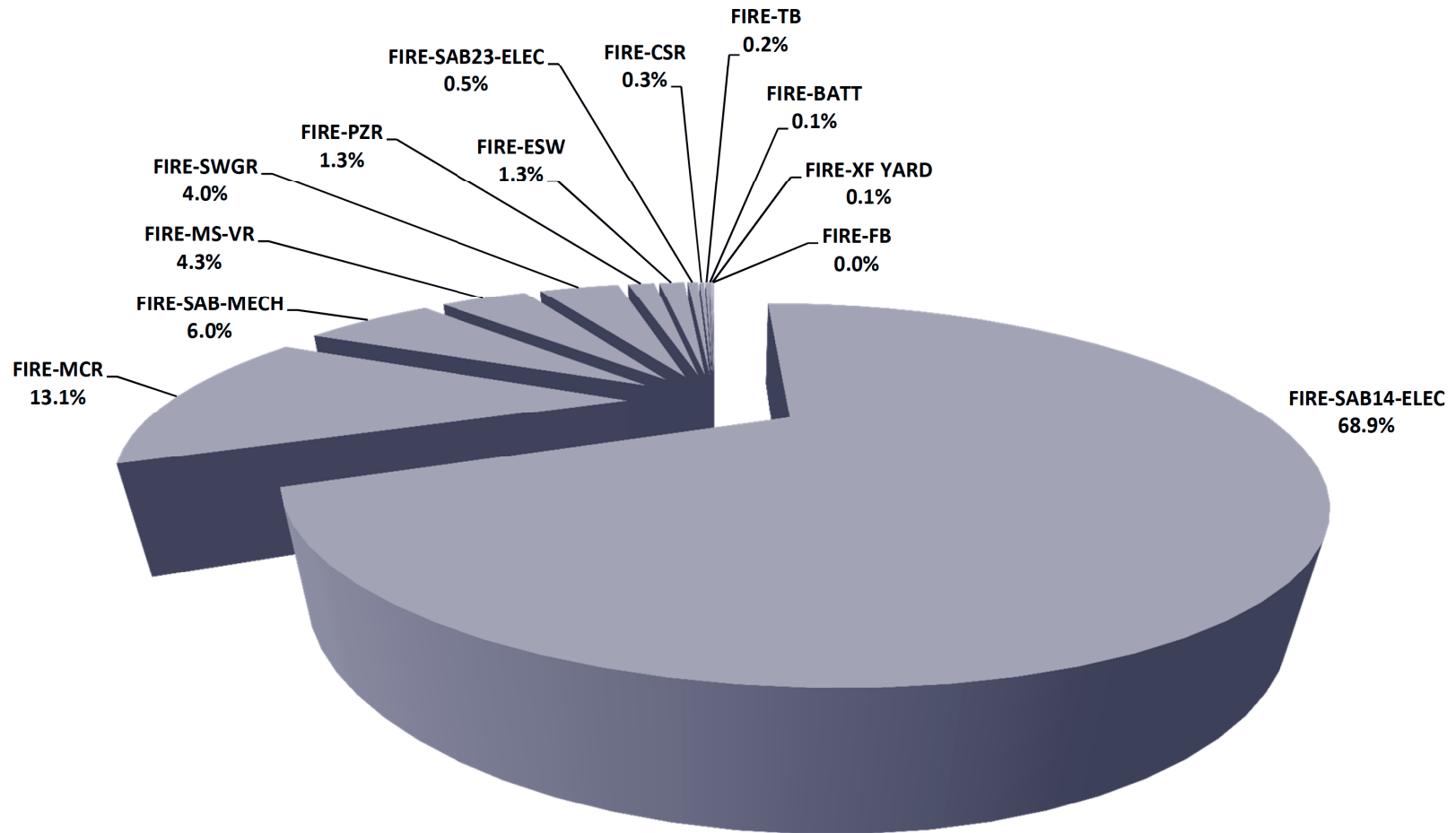

Figure 19.1-15—U.S. EPR Initiating Event Contributions - Level 1 Fire



Fire CDF: 1.8E-07/yr

REV 005  
EPR6065 T2

---

**Figure 19.1-16—Cross-section of Safeguard Building 4 Illustrating the PRA Fire Areas**

---

**Figure 19.1-17—Cross-section of Safeguard Building 2 Illustrating the PRA Fire Areas**



Figure 19.1-18—U.S. EPR Level 1 Internal Fire Events Uncertainty Analysis Results - Cumulative Distribution for Fire Events CDF

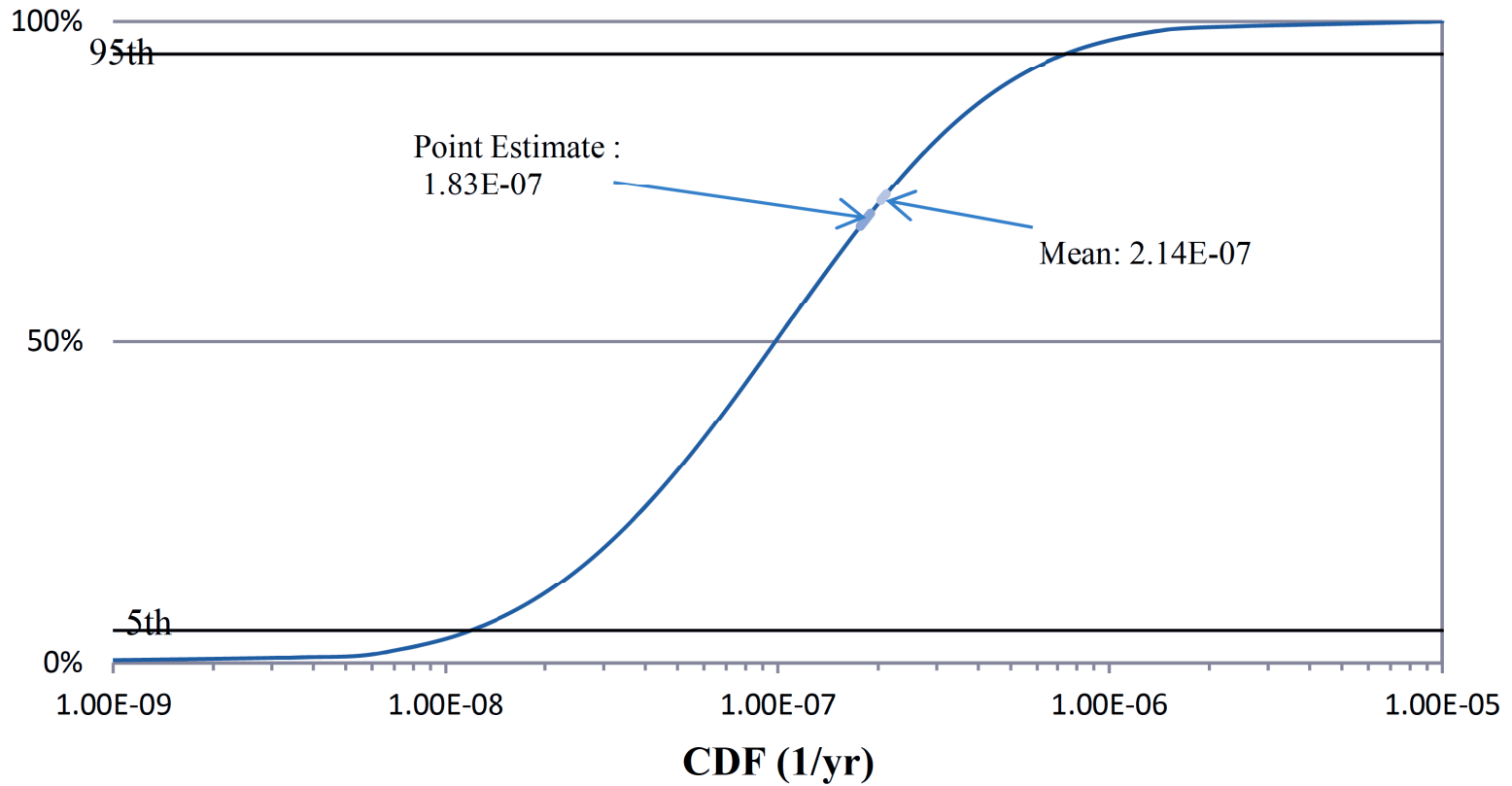

REV 005  
EPR6070 T2

Figure 19.1-19—U.S. EPR Level 2 Fire Events Uncertainty Analysis Results - Cumulative Distribution Function for Fire Events LRF

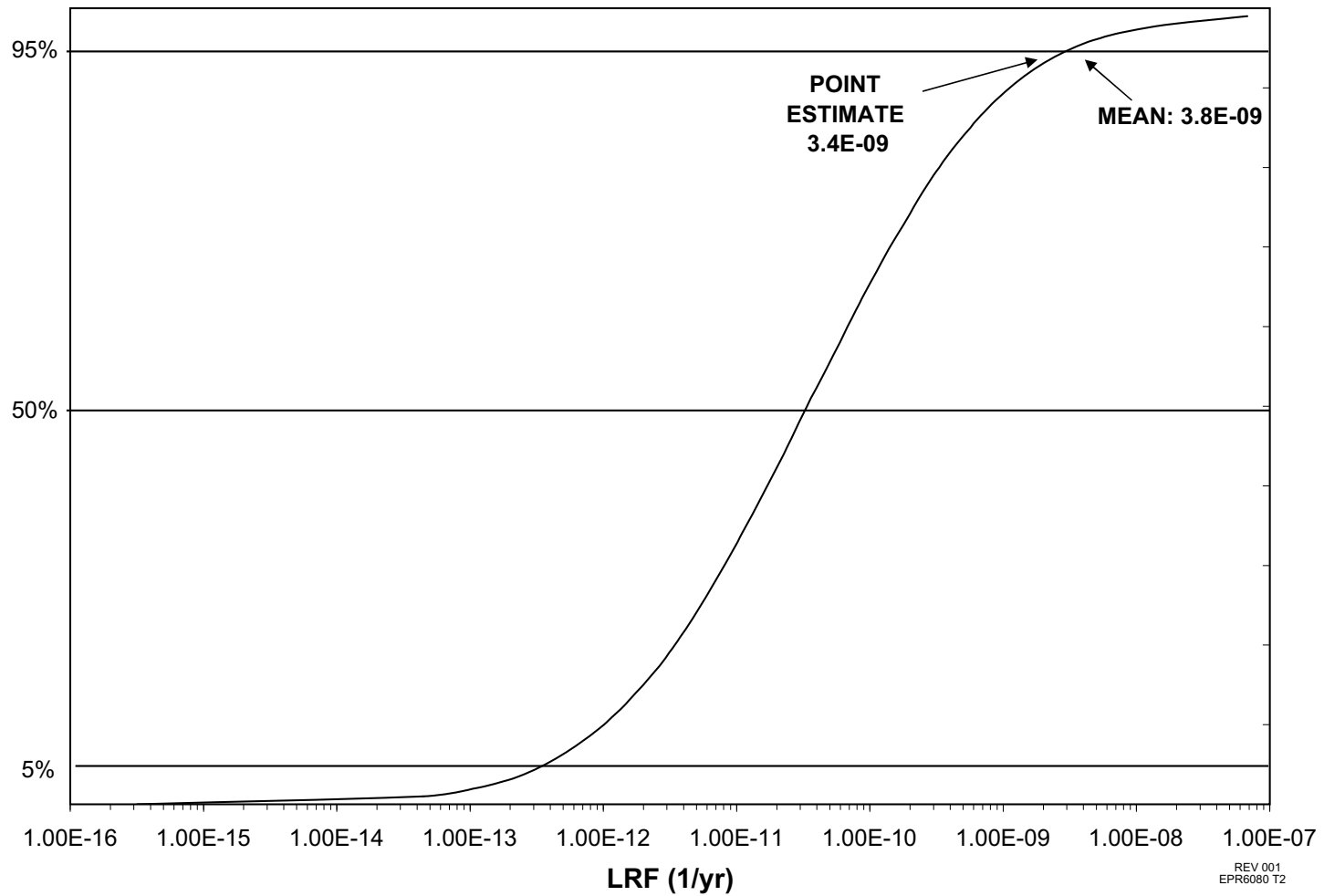
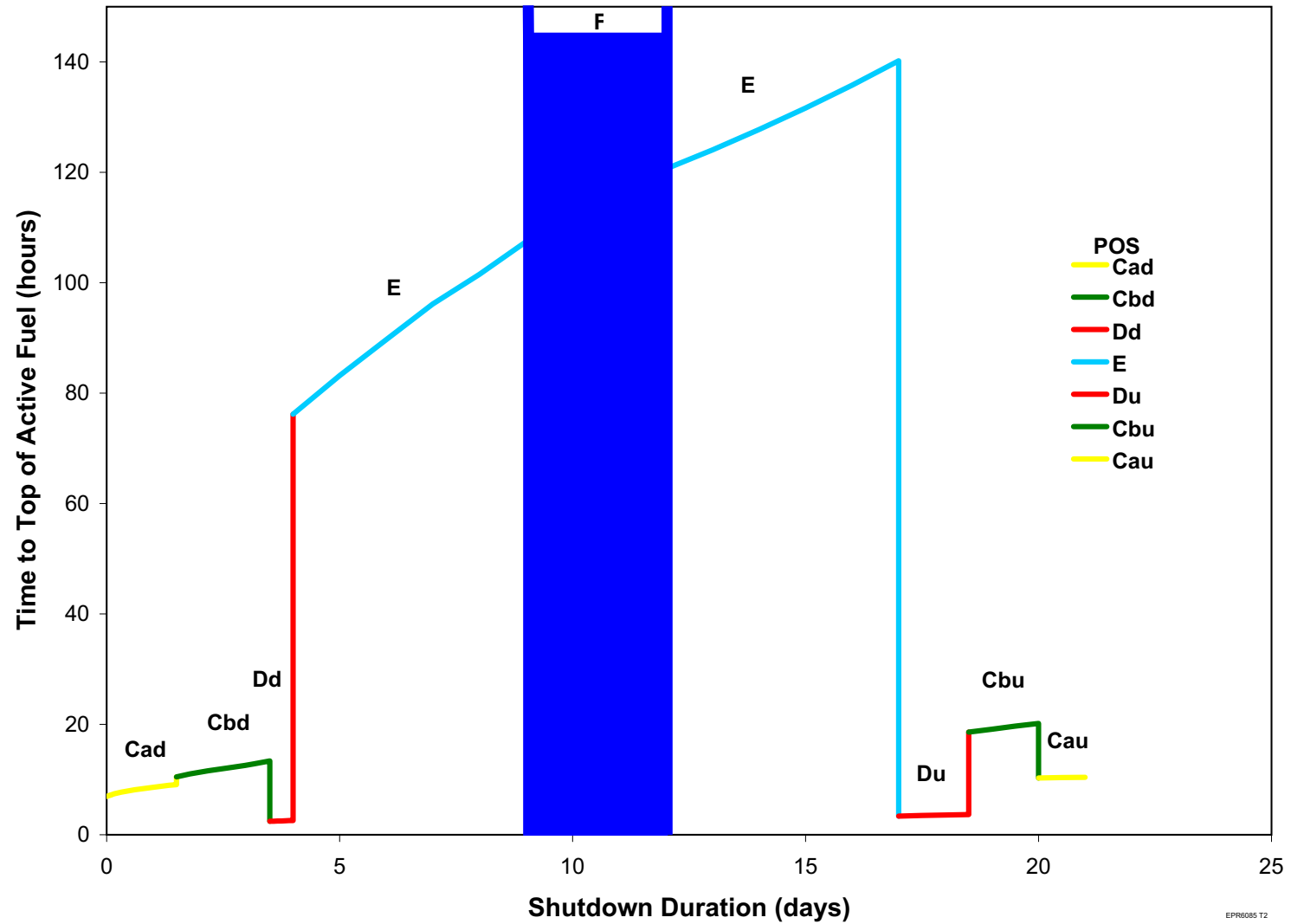
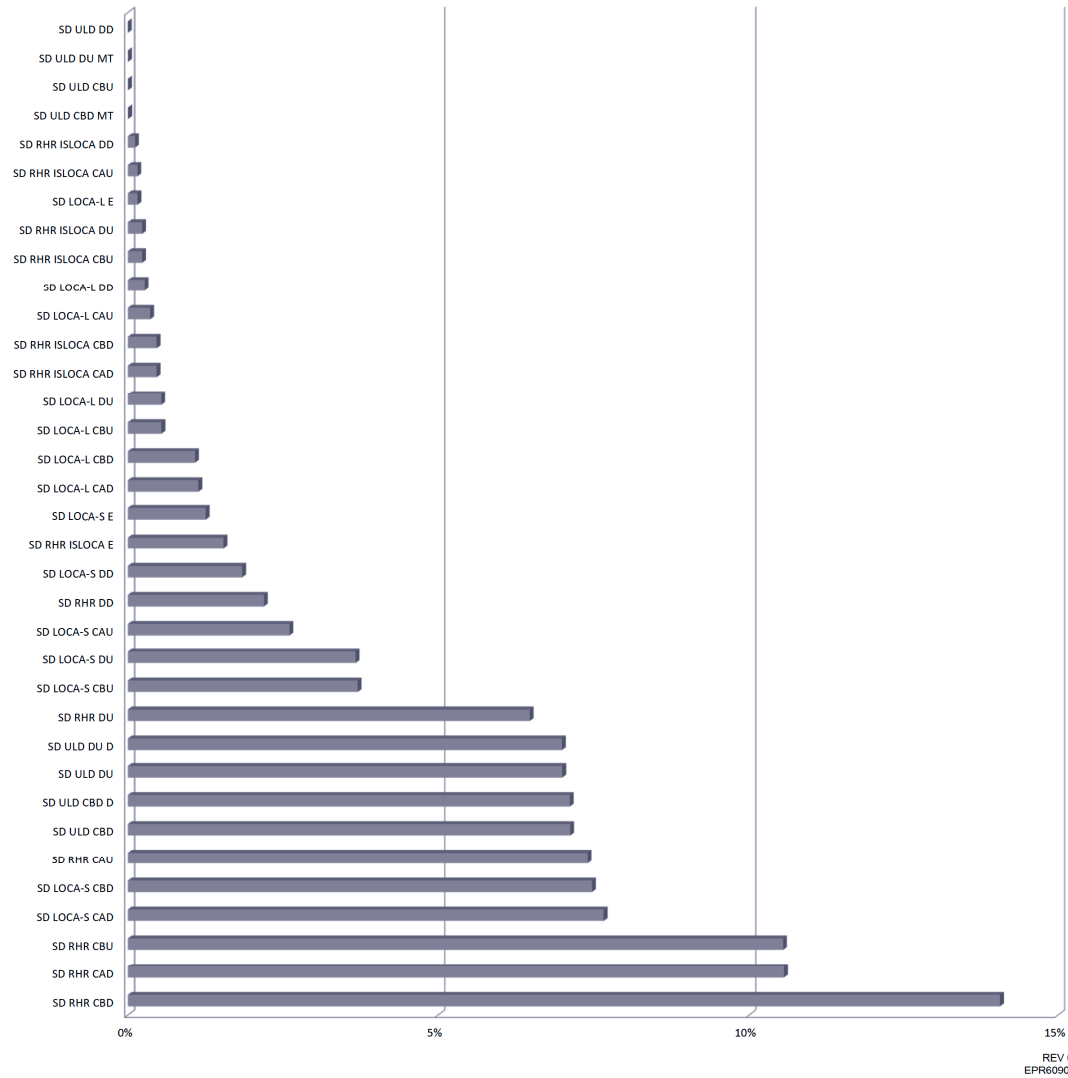

Figure 19.1-20—Time to TAF - Level 1 Shutdown



EPR6085 T2

Figure 19.1-21—U.S. EPR Initiating Event Contributions - Level 1 Shutdown



REV 005  
EPR6090 T2

Figure 19.1-22—U.S. EPR Shutdown State Contribution - Level 1 Shutdown

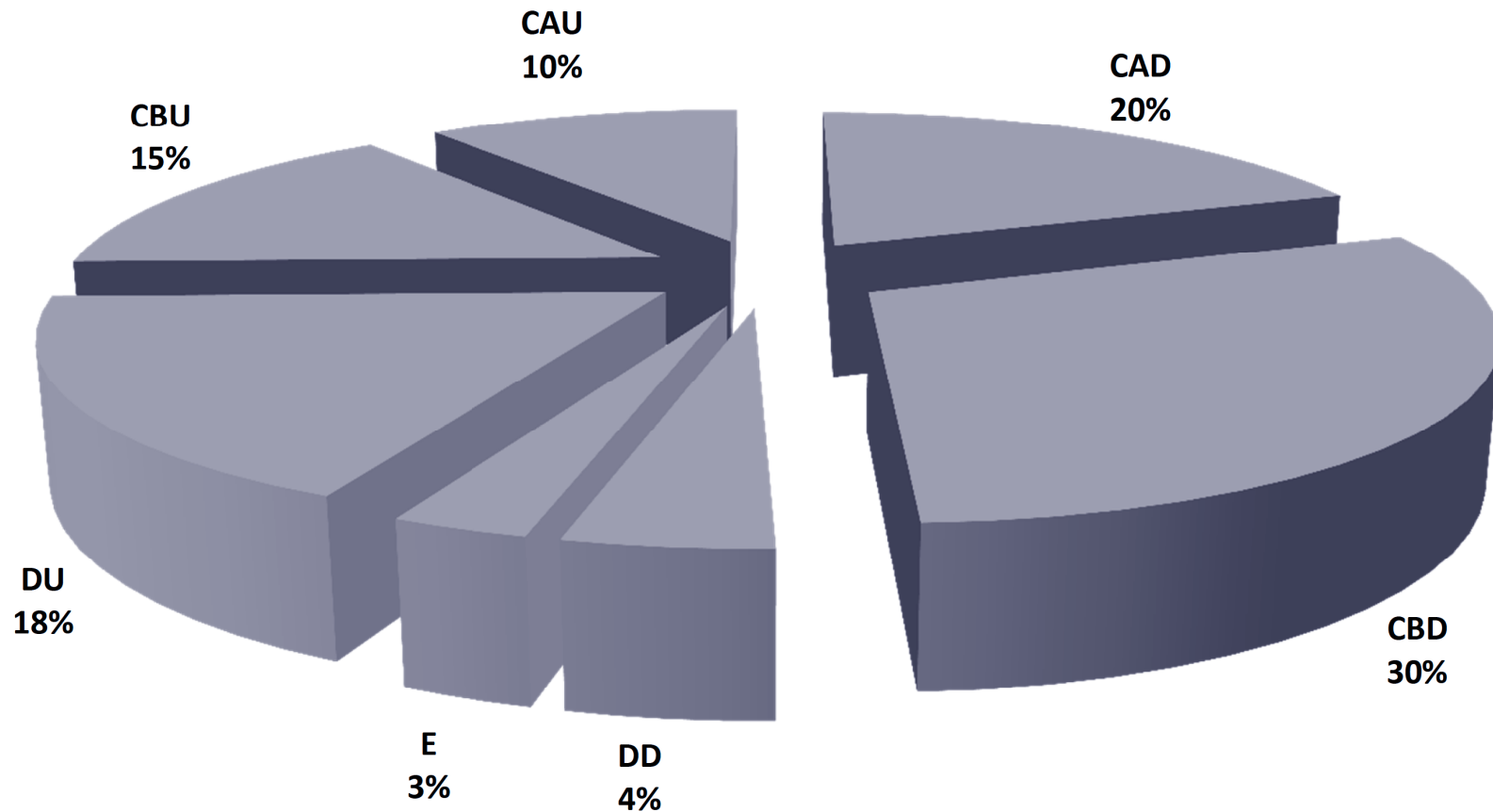

**Shutdown CDF = 6.0E-08/yr**

REV 005  
EPR6095 T2

Figure 19.1-23—U.S. EPR Level 1 Shutdown Events Uncertainty Analysis Results - Cumulative Distribution for Low Power and Shutdown CDF

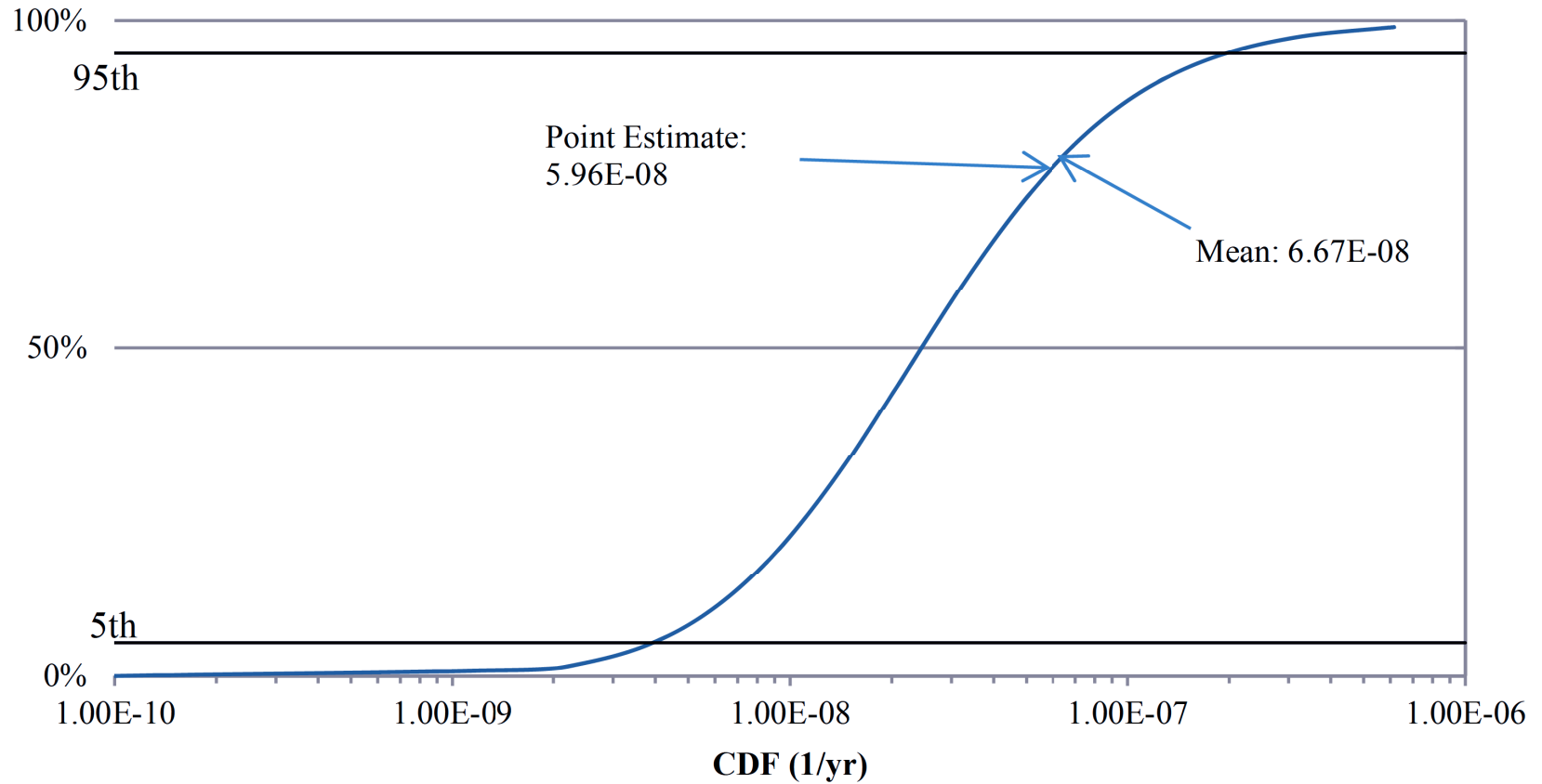

REV 005  
EPR6100 T2

Figure 19.1-24—U.S. EPR Level 1 Initiating Event Contributions to Total CDF at Power

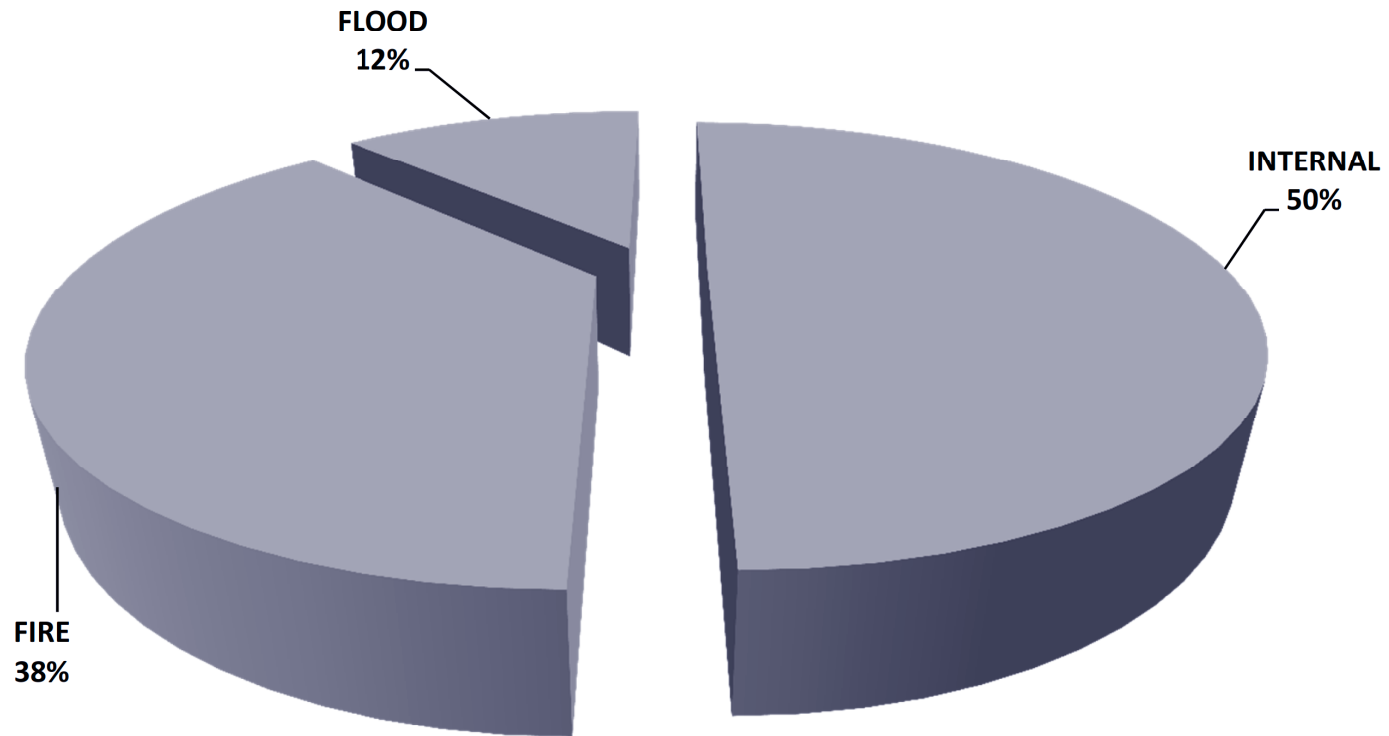

**AT POWER TOTAL CDF = 4.9E-07 / yr**

REV 005  
EPR6105 T2

Figure 19.1-25—U.S. EPR POS Contributions to Total CDF

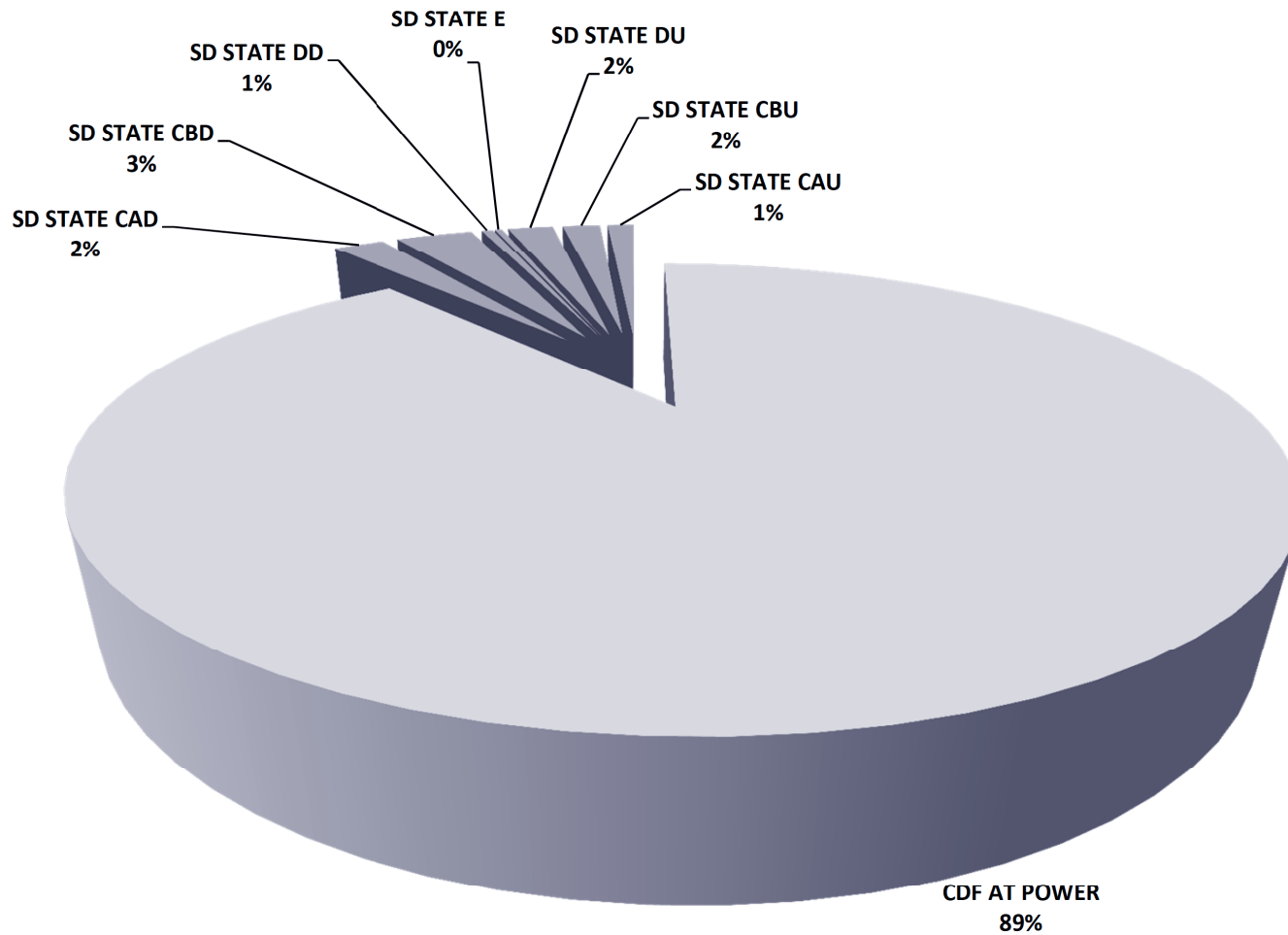

**Total CDF = 5.5E-07 / yr**

REV 005  
EPR6110 T2



Figure 19.1-26—U.S. EPR Level 2 Initiating Event Contribution to Total At-Power LRF

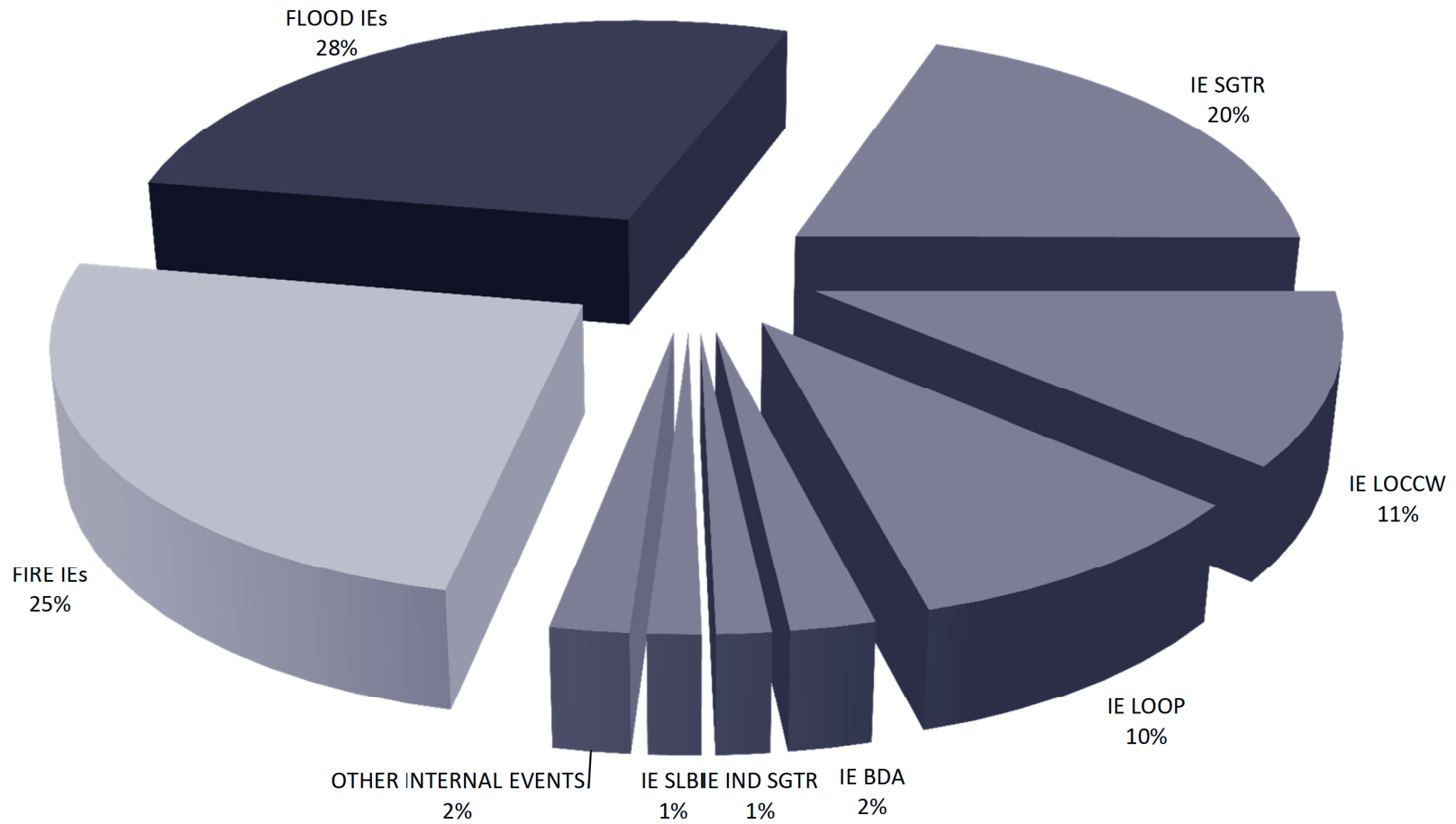

Total At-Power LRF = 3.01E-08

REV 005  
EPR6130 T2

Figure 19.1-27—U.S. EPR Level 2 Release Category Contribution to Total At-Power LRF

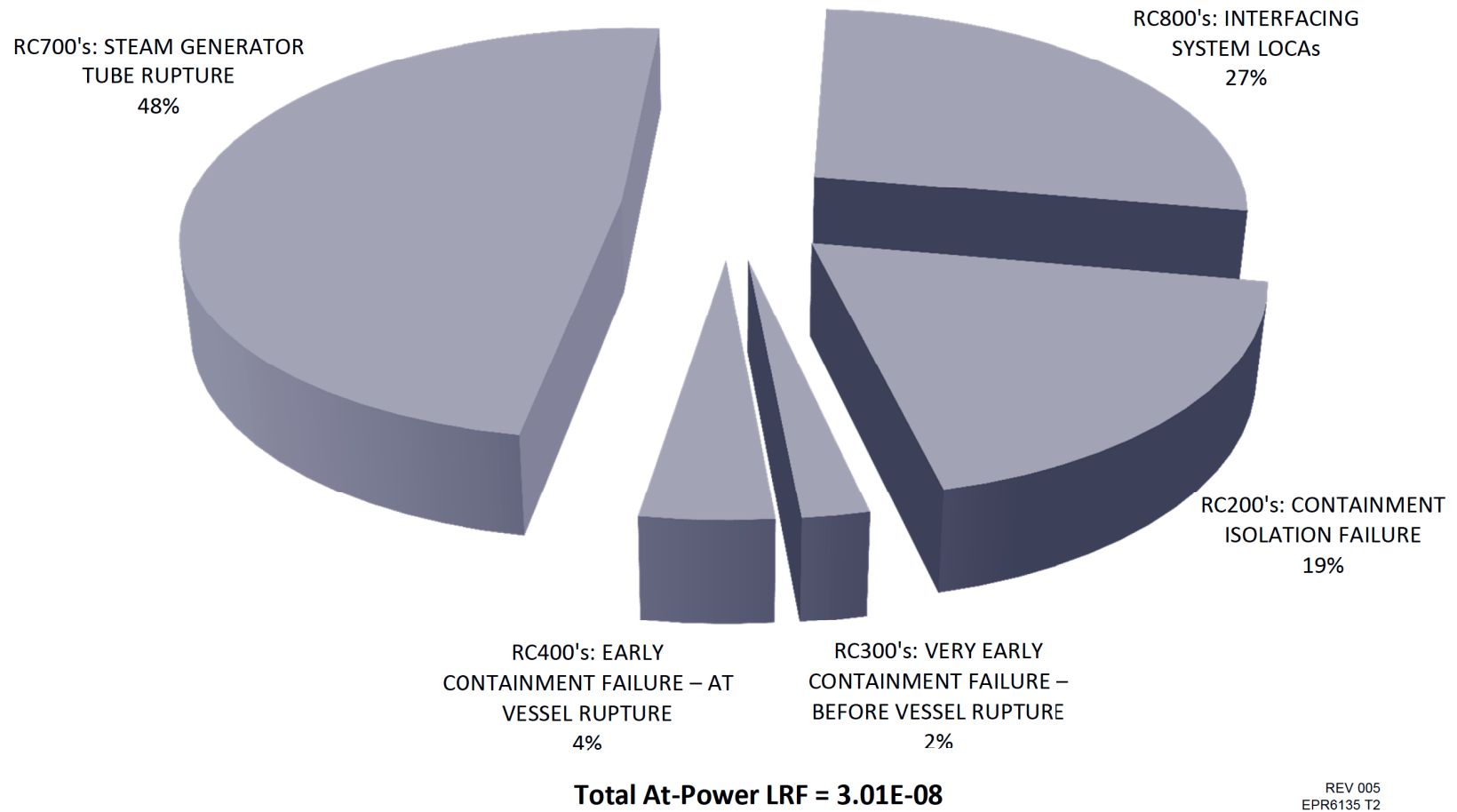

Figure 19.1-28—Deleted.

Figure 19.1-29— U.S. EPR Level 1 Internal Events Total Uncertainty Analysis Results - Cumulative Distribution for All Internal, Fire and Flood Events CDF

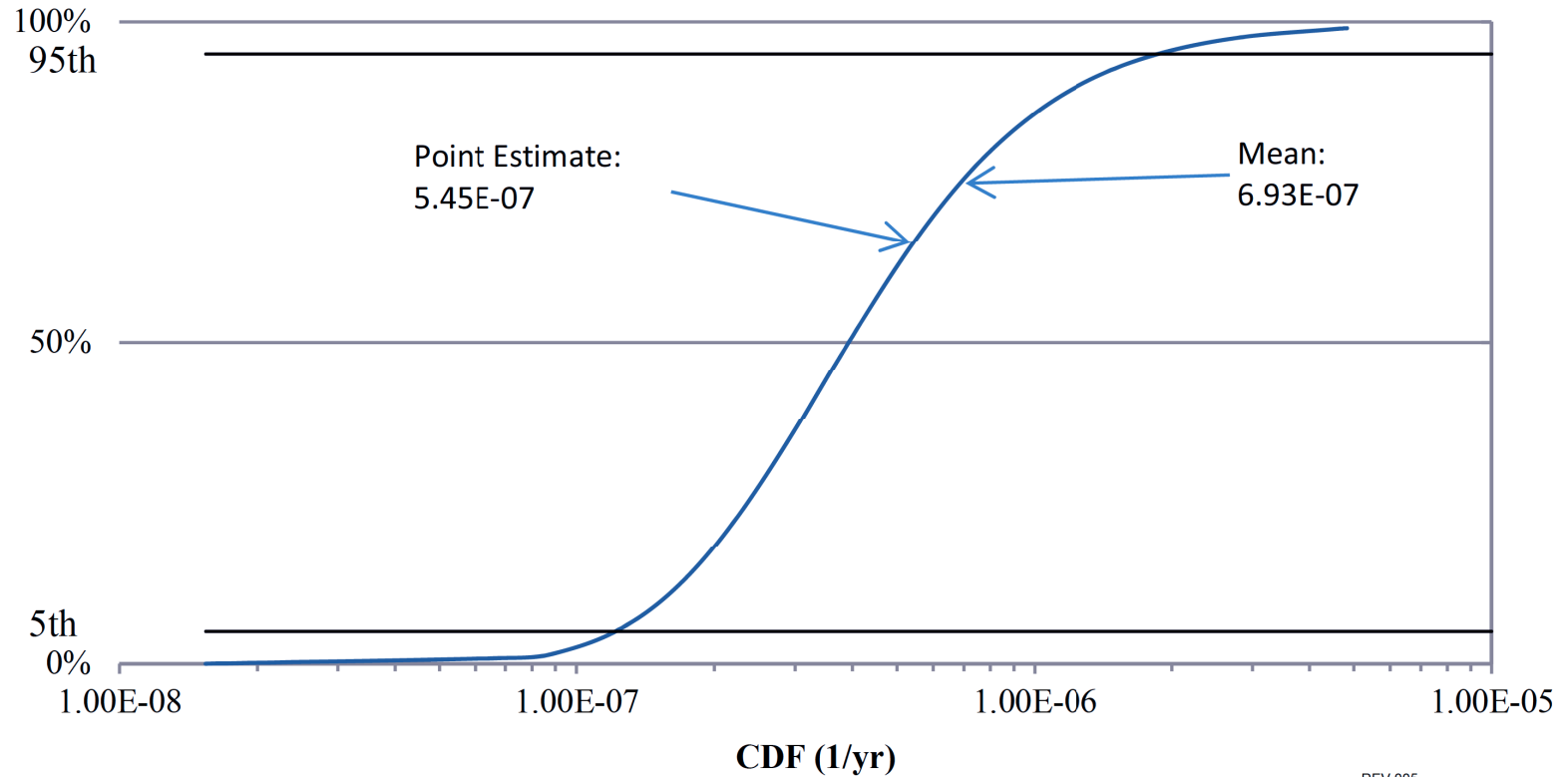
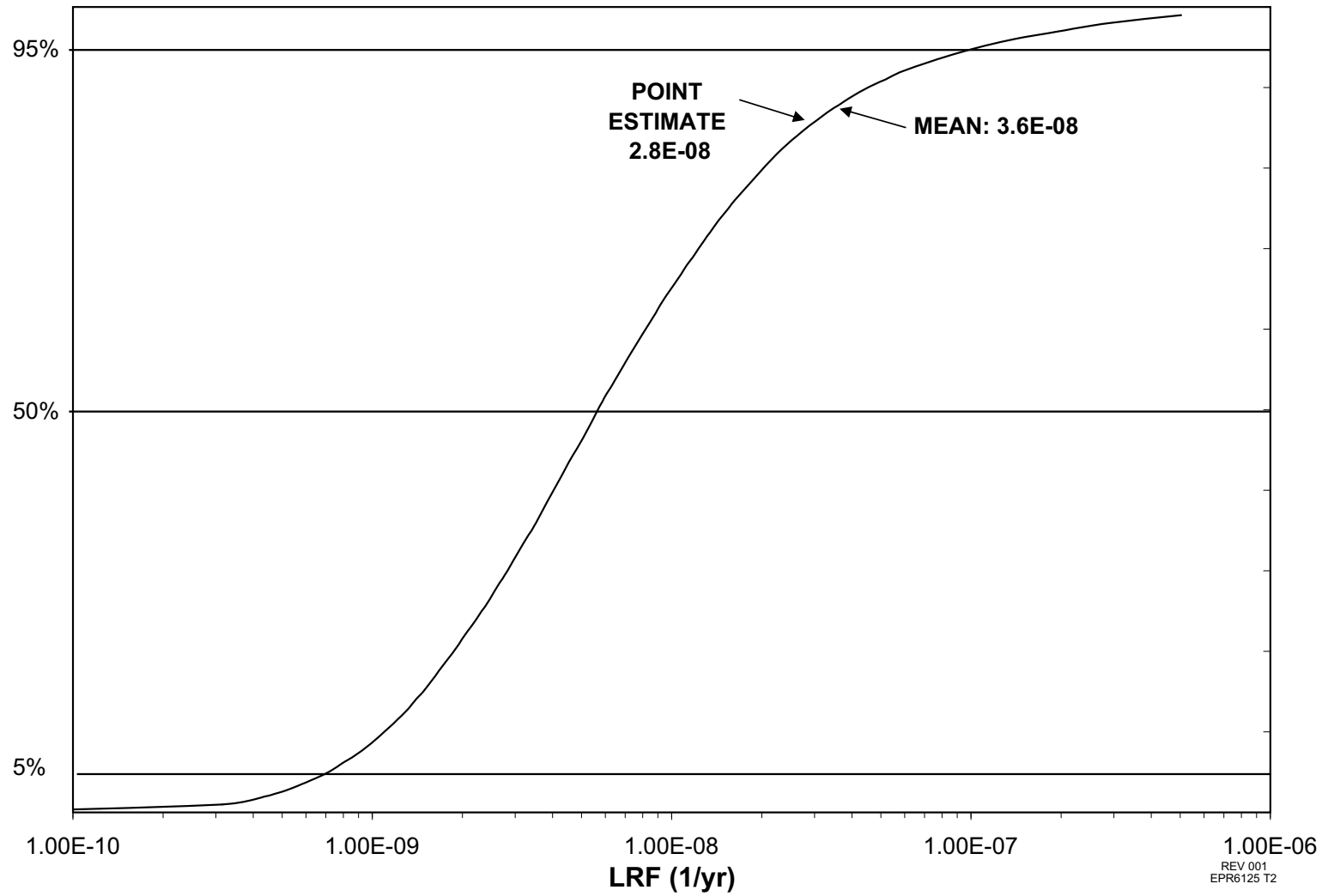

Figure 19.1-30—U.S. EPR Level 2 Internal Events Total Uncertainty Analysis Results - Cumulative Distribution for All Internal, Fire and Flood Events LRF



REV 001  
EPR6125 T2

**Figure 19.1-31—Deleted**

Figure 19.1-32—POS CA Release Category Contributions to Shutdown LRF

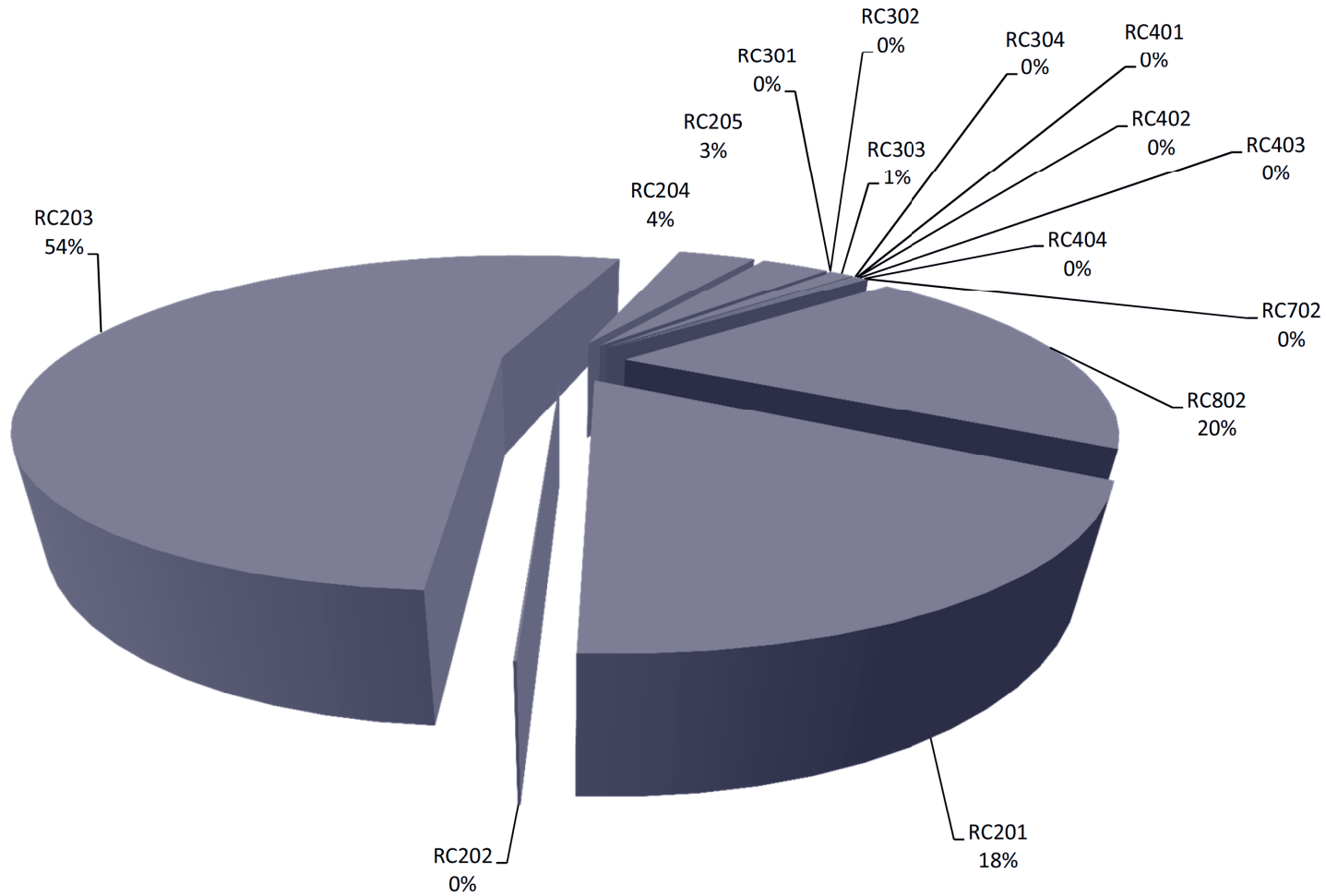

POS CA Shutdown LRF = 1.9 E-09/yr

REV 005  
EPR6145 T2

Figure 19.1-33—POS CB Release Category Contributions to Shutdown LRF

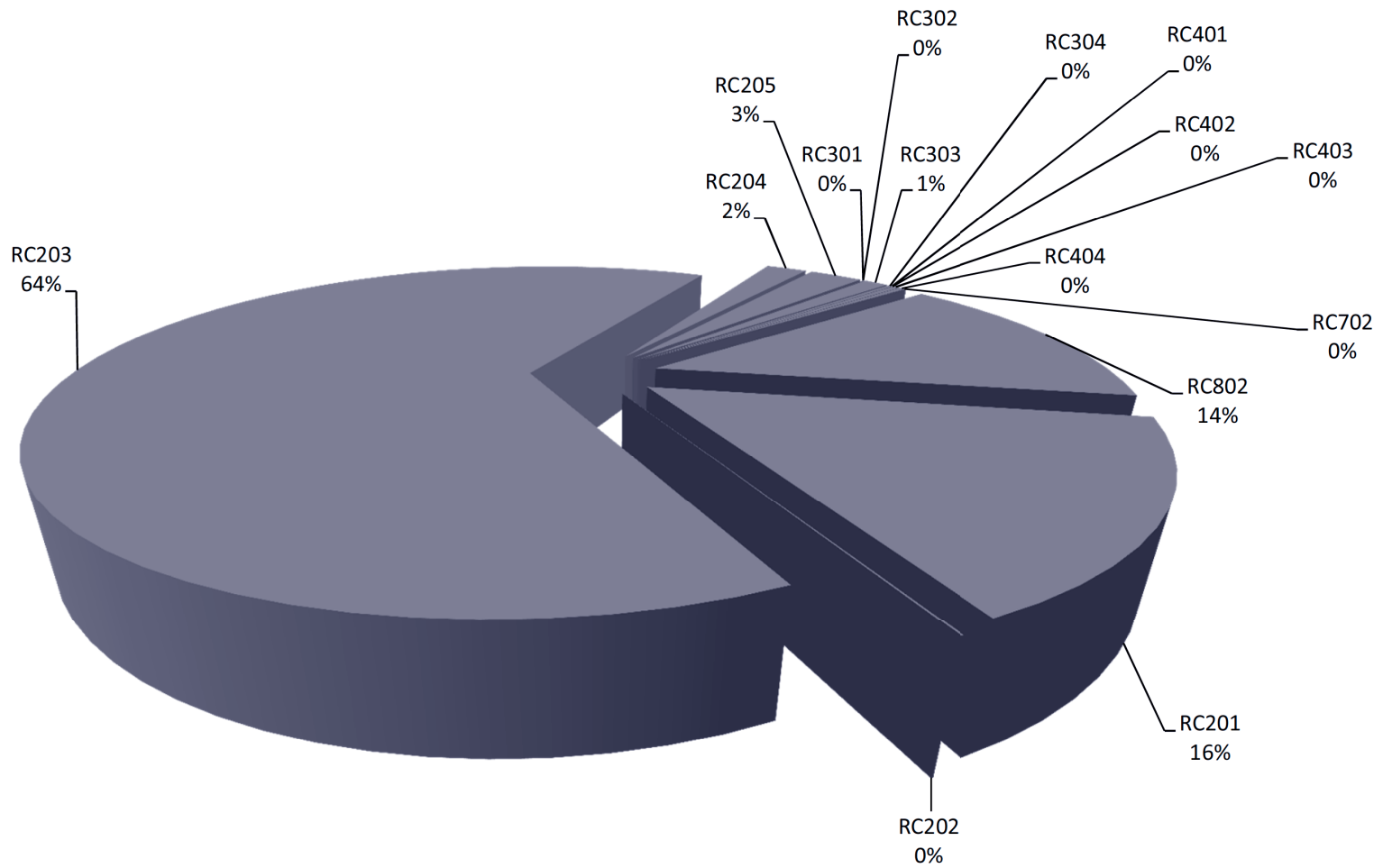

POS CB Shutdown LRF = 3.0 E-09/yr

REV 005  
EPR6150 T2

Figure 19.1-34—POS D Release Category Contributions to Shutdown LRF

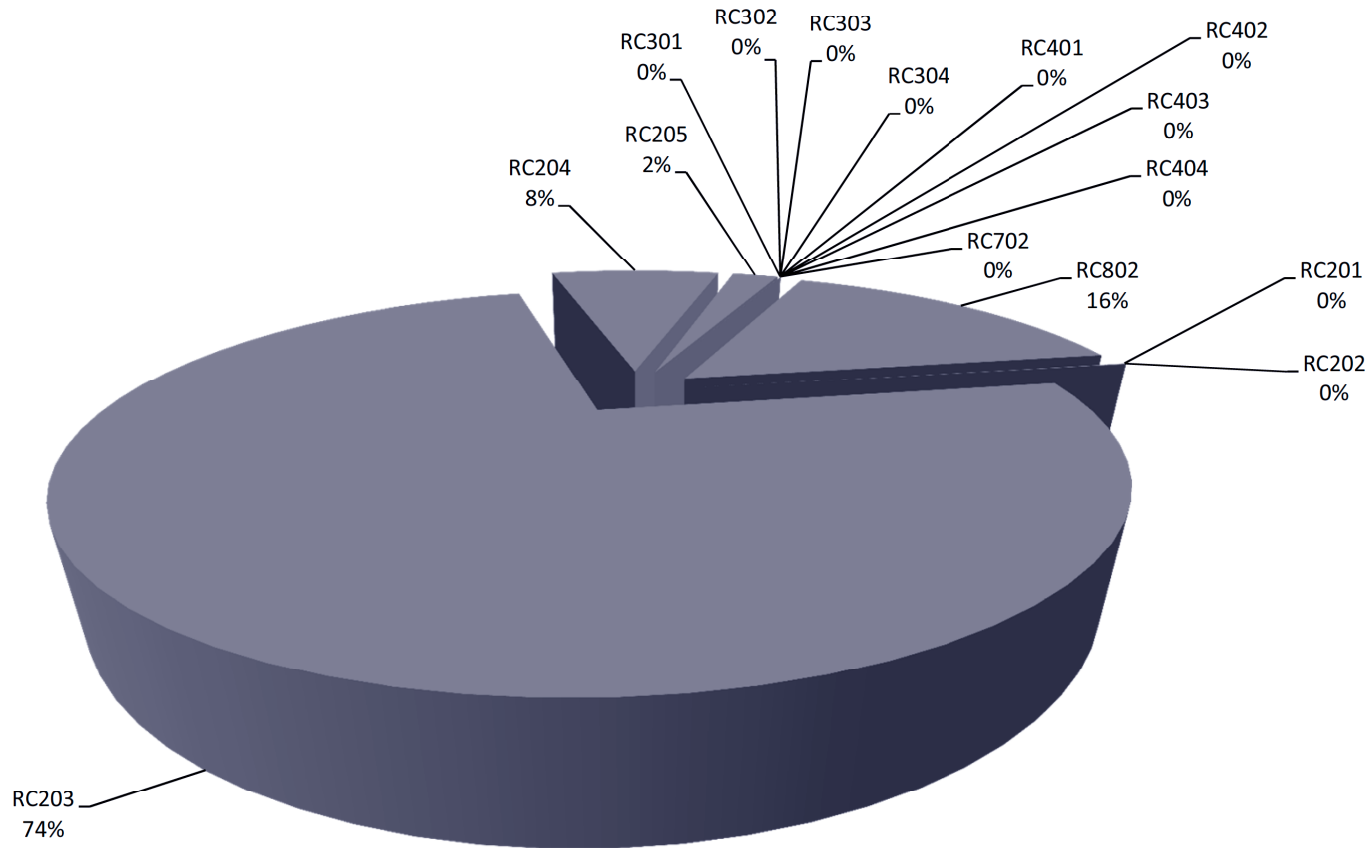

POS D Shutdown LRF = 1.3 E-09/yr

REV 005  
EPR6155 T2



Figure 19.1-35—POS E Release Category Contributions to Shutdown LRF

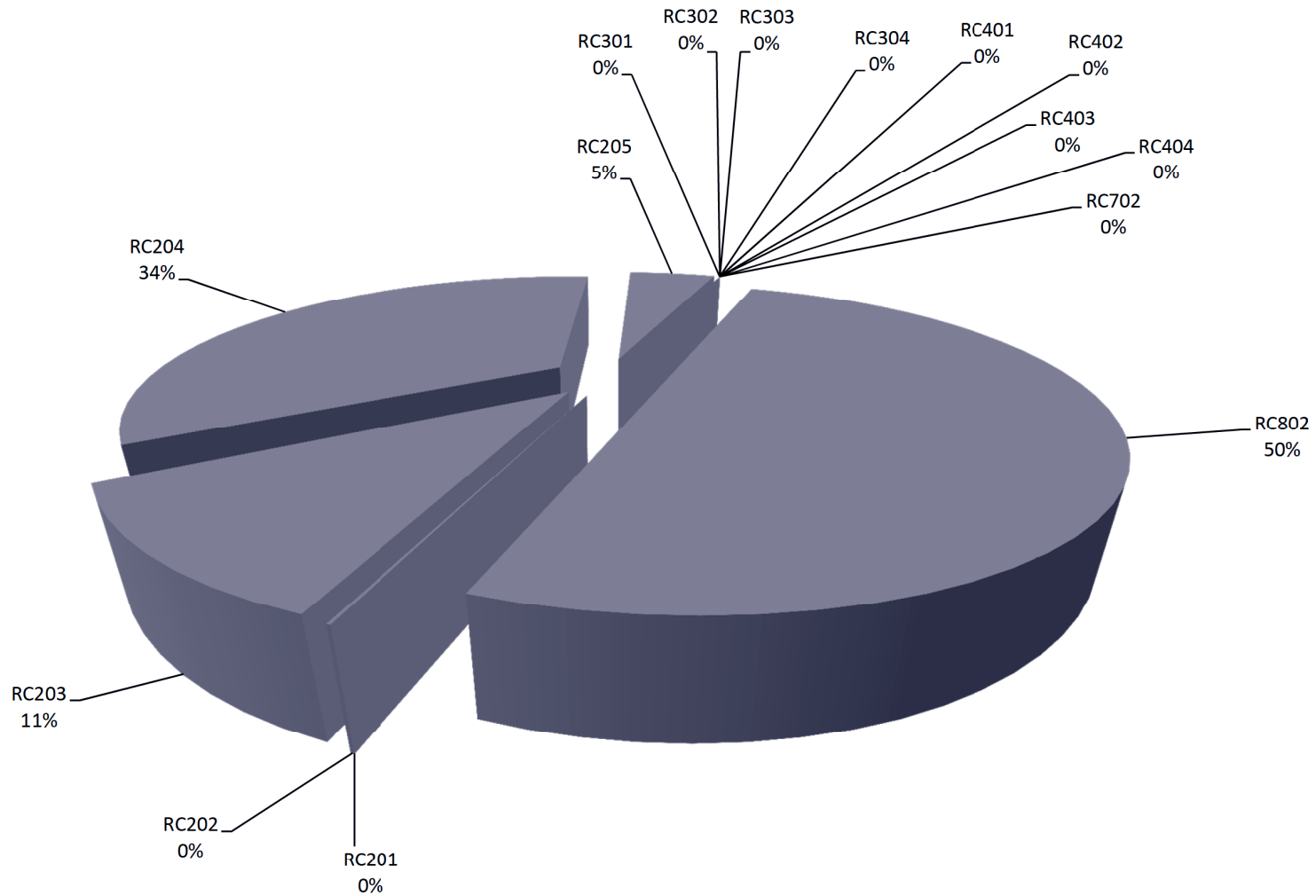

POS E Shutdown LRF = 1.8 E-09/yr

REV 005  
EPR6160 T2

Figure 19.1-36—POS Contributions to Shutdown LRF

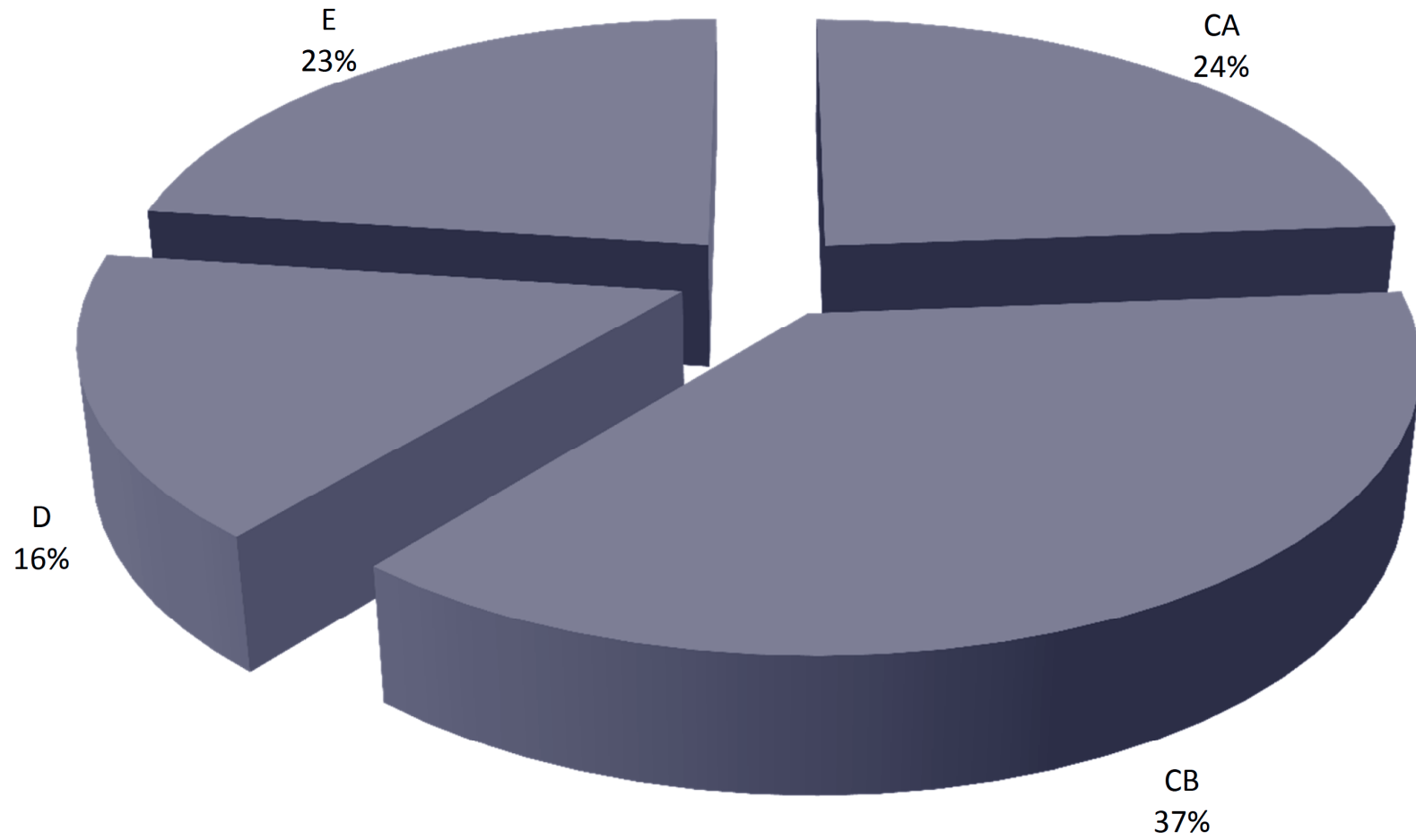

Shutdown LRF = 7.9 E-09/yr

REV 005  
EPR6165 T2

Figure 19.1-37—Initiating Events Contributions to Shutdown LRF

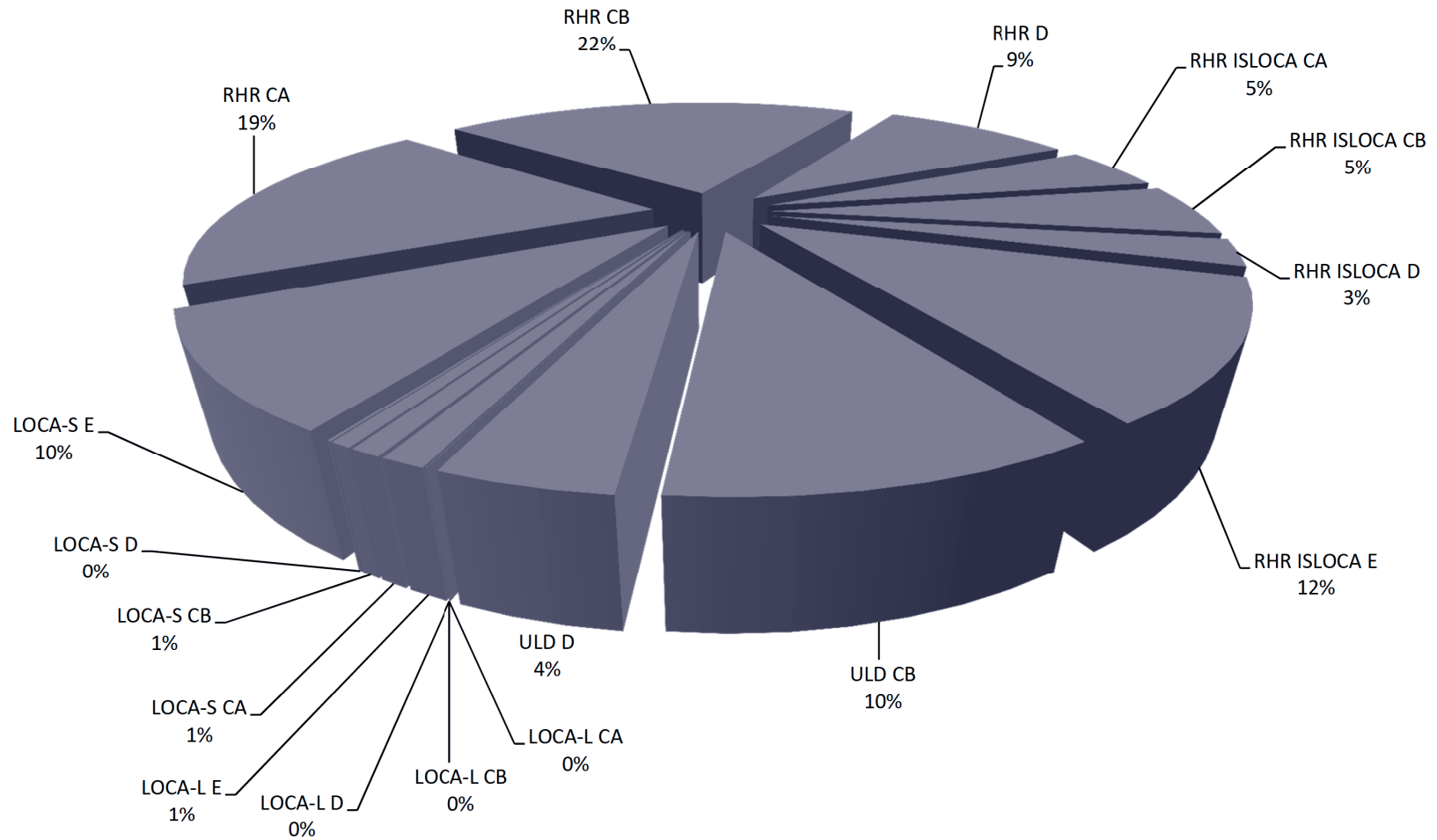

Shutdown LRF = 7.9 E-09/yr

REV 005  
EPR6170 T2

Figure 19.1-38—POS Contributions to Total LRF

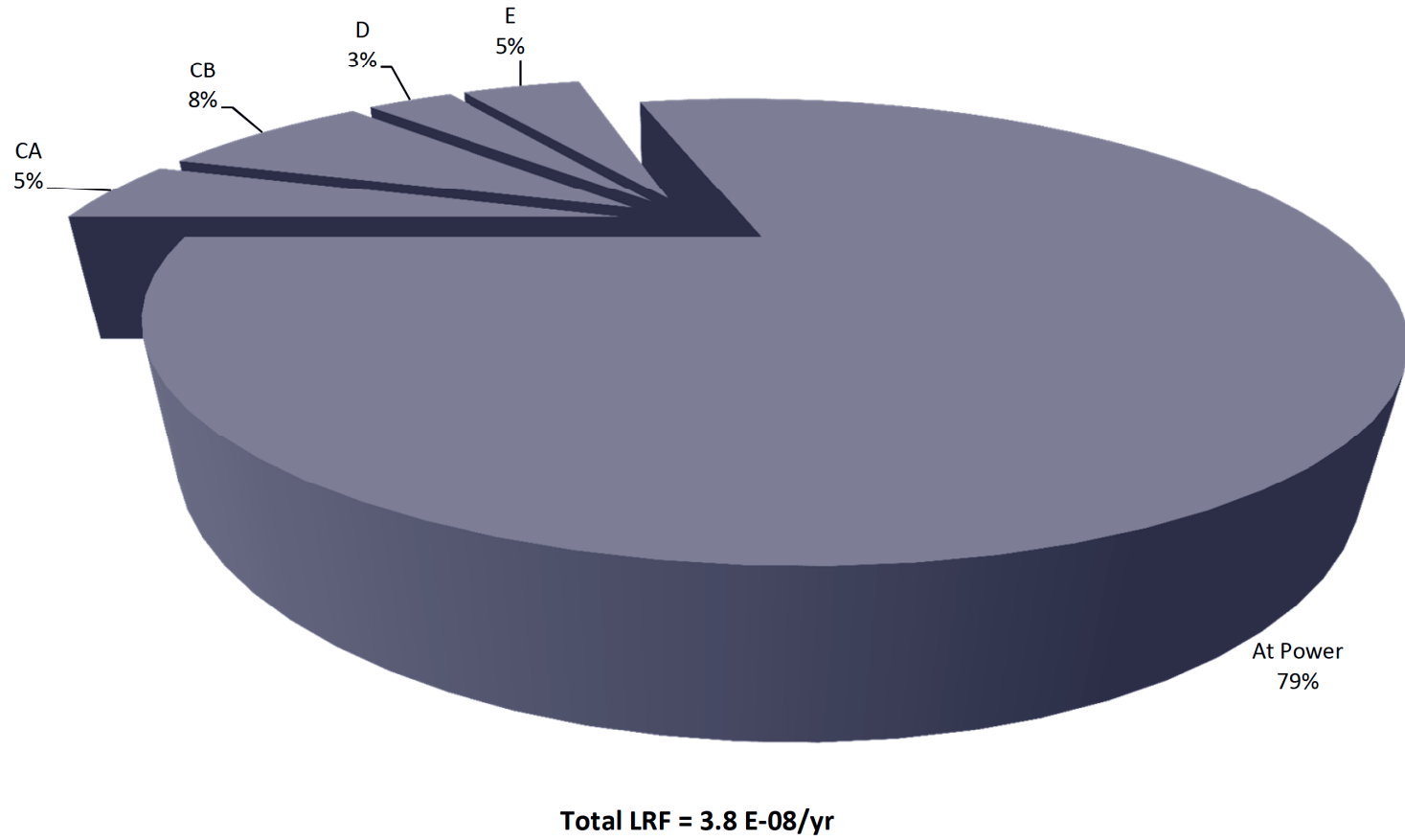

REV 005  
EPR6175 T2

[Next File](#)