



Tennessee Valley Authority, 1101 Market Street, Chattanooga, Tennessee 37402

EA-12-050

February 28, 2013

10 CFR 2.202

ATTN: Document Control Desk
U.S. Nuclear Regulatory Commission
Washington, D.C. 20555-0001

Browns Ferry Nuclear Plant, Units 1, 2, and 3
Facility Operating License Nos. DPR-33, DPR-52, and DPR-68
NRC Docket Nos. 50-259, 50-260, and 50-296

Subject: Tennessee Valley Authority (TVA) - Overall Integrated Plan in Response to the March 12, 2012, Commission Order Modifying Licenses with Regard to Requirements for Reliable Hardened Containment Vents (Order Number EA-12-050) for Browns Ferry Nuclear Plant

- References:
1. NRC Order Number EA-12-050, Issuance of Order to Modify Licenses with Regard to Reliable Hardened Containment Vents, dated March 12, 2012, (ML12054A694)
 2. NRC Interim Staff Guidance JLD-ISG-2012-02, Compliance with Order EA-12-050, Reliable Hardened Containment Vents, Revision 0, dated August 29, 2012 (ML12229A475)
 3. Letter from TVA to NRC, "Initial Status Report in Response to March 12, 2012, Commission Order Modifying Licenses with Regard to Requirements for Mitigation Strategies for Beyond-Design-Basis External Events (Order Number EA-12-049)," dated October 29, 2012 (ML12307A104)

D030
NRR

On March 12, 2012, the Nuclear Regulatory Commission (NRC) issued an immediately effective order (Order Number EA-12-050) entitled "Issuance of Order to Modify Licenses with Regard to Reliable Hardened Containment Vents" to "All Operating Boiling-Water Reactor Licensees with Mark I and Mark II Containments" (Reference 1). The Order indicated that as a result of the NRC's evaluation of the lessons learned from the March 2011 accident at Fukushima Dai-ichi, the NRC determined that certain actions are required by all Operating Boiling-Water Reactor Licensees with Mark I and II Containments. Specifically, the NRC required certain actions to be taken to "have a reliable hardened vent to remove decay heat and maintain control of containment pressure within acceptable limits following events that result in the loss of active containment heat removal capability or prolonged station blackout (SBO)." Specific requirements are outlined in Attachment 2 to the Order.

The Order requires submission of an overall integrated plan including a description of how compliance with the requirements described in Attachment 2 of the Order will be achieved. The Order requires the plan to be submitted to the NRC for review by February 28, 2013. In addition, the Order requires submission of an initial status report 60 days following issuance of the final interim staff guidance and at six month intervals following submittal of the overall integrated plan. The interim staff guidance containing specific details on implementation of the requirements of the order was scheduled to be issued in August 2012. Finally, the order requires full implementation of its requirements no later than two refueling cycles after submittal of the overall integrated plan, or December 31, 2016, whichever comes first.

The NRC issued Interim Staff Guidance on August 29, 2012 (Reference 2) which provides direction regarding the content of the overall integrated plan. Reference 2, Section 4.0 contains the specific reporting requirements for the overall integrated plan.

By letter dated October 29, 2012 (Reference 3), TVA submitted an initial status report regarding reliable hardened containment vents, as required by the Reference 1 Order.

The purpose of this letter is to provide the overall integrated plan pursuant to Section IV, Condition C.1, of the Reference 1 Order. This letter confirms that TVA has received Reference 2 interim staff guidance and has an overall integrated plan developed in accordance with the guidance for hardened containment vents for the Browns Ferry Nuclear Plant (BFN).

For purposes of compliance with Order EA-12-050 (Reference 1), TVA plans to use a wetwell vent. The wetwell vent will be used for initial response after the event to mitigate containment overpressure and subsequent increased temperature in the wetwell. A drywell vent will also be installed to be used if the water level in the wetwell rises to render the wetwell vent inoperable.

U.S. Nuclear Regulatory Commission
Page 3
February 28, 2013

The information in the enclosure provides the BFN overall integrated plan for reliable hardened vents. The integrated plan is based on conceptual design information. Final design details and associated procedure guidance, as well as any revisions to the information contained in the enclosure, will be provided in the 6-month integrated plan updates required by the Reference 1 Order. As discussed at an NRC Commission Meeting on January 9, 2013, TVA is evaluating potential designs for an optional engineered filter that could potentially be added to the Hardened Containment Vent System (HCVS) downstream of the piping as it exits the Reactor Building. An update on TVA's evaluation of a decision to install an engineered filter will be included in the required six month update.

The enclosure describes the plans that TVA will use to meet the regulatory requirements outlined in Attachment 2 of Reference 1, but does not identify any additional actions to be taken by TVA. Therefore, this letter contains no regulatory commitments.

If you have questions regarding this letter, please contact Kevin Casey at (423) 751-8523.

I declare under penalty of perjury that the foregoing is true and correct.
Executed on the 28th day of February 2012.

Respectfully,



J.W. Shea
Vice President, Nuclear Licensing

Enclosure:

Browns Ferry Nuclear Plant, Reliable Hardened Containment Vent Overall Integrated Plan

Enclosure
cc (Enclosure):

NRR Director - NRC Headquarters
NRC Regional Administrator - Region II
NRR Project Manager - Browns Ferry Nuclear Plant
NRC Senior Resident Inspector - Browns Ferry Nuclear Plant
Mr. Robert J. Fretz, Jr. NRR/JLD/PMB, NRC
Mr. Robert L. Dennig, NRR/DSS/SCVB, NRC

ENCLOSURE

**BROWNS FERRY NUCLEAR PLANT
RELIABLE HARDENED CONTAINMENT VENTS
OVERALL INTEGRATED PLAN**

TENNESSEE VALLEY AUTHORITY
BROWNS FERRY NUCLEAR PLANT
UNITS 1, 2, AND 3

RELIABLE HARDENED CONTAINMENT
VENTS

OVERALL INTEGRATED PLAN

Table of Contents:

Section 1: System Description

Section 2: Design objectives

Requirement 1.1.1 - Minimize the Reliance on Operator Actions

Requirement 1.1.2 - Minimize Plant Operators' Exposure to Occupational Hazards

Requirement 1.1.3 - Minimize Radiological Consequences

Section 3: Operational Characteristics

Requirement 1.2.1 - Capacity to Vent Equivalent of 1%

Requirement 1.2.2 - HCVS Shall be Accessible to Plant Operators

Requirement 1.2.3 - Prevent Inadvertent Actuation

Requirement 1.2.4 - Monitor the Status of the Vent System

Requirement 1.2.5 - Monitor the Effluent Discharge for Radioactivity

Requirement 1.2.6 - Minimize Unintended Cross Flow of Vented Fluids

Requirement 1.2.7 - Provision for the Operation, Testing, Inspection and Maintenance

Requirement 1.2.8 - Design Pressures

Requirement 1.2.9 - Discharge Release Point

Section 4: Applicable Quality Requirements

Requirement 2.1 - Containment Isolation Function

Requirement 2.2 - Reliable and Rugged Performance

Section 5: Procedures and Training

Requirement 3.1 - Develop, Implement, and Maintain Procedures

Requirement 3.2 - Train Appropriate Personnel

Section 6: Implementation Schedule Milestones

Section 7: Changes/Updates to this Overall Integrated Implementation Plan

Section 8: Figures/Diagrams

References:

Generic Letter 89-16, Installation of a Hardened Wetwell Vent, dated September 1, 1989

Order EA-049, Mitigation Strategies for Beyond-Design-Basis External Events,
dated March 12, 2012

Order EA-050, Reliable Hardened Containment Vents, dated March 12, 2012

JLD-ISG-2012-02, Compliance with Order EA-12-050, Reliable Hardened Containment Vents,
dated August 29, 2012

NRC Responses to Public Comments, Japan Lessons-Learned Project Directorate Interim Staff
Guidance JLD-ISG-2012-02: Compliance with Order EA-12-050, Order Modifying Licenses
with Regard to Reliable Hardened Containment Vents, ADAMS Accession No.
ML12229A477, dated August 29, 2012

NEI 12-06, Diverse and Flexible Coping Strategies (FLEX) Implementation Guide, Revision -,
dated August 2012.

BFN Acronym List - HCVS

AOV	Air Operated Valve
ASME OM	American Society of Mechanical Engineers Operation and Maintenance Code
BWROG	BWR Owners Group
CAP	Containment Accident Pressure
CIV	Containment Isolation Valve
CLTP	Current Licensed Thermal Power
DBLOCA	Design Basis Loss of Coolant Accident
ECCS	Emergency Core Cooling System
ELAP	Extended Loss of AC Power
EOI	Emergency Operating Instruction
EPU	Extended Power Uprate
FCV	Flow Control Valve
FLEX	Flexible and Diverse Coping Mitigation Strategies
FSAR	Final Safety Analysis Report
HCV	Hand Control Valve
HCVS	Hardened Containment Vent System
ISG	Interim Staff Guidelines
KVA	KiloVolt-Ampere
MCR	Main Control Room
NEI	Nuclear Energy Institute
PCPL	Primary Containment Pressure Limit
RMS	Radiation Monitoring System
SBO	Station Black Out
SGTS	Standby Gas Treatment System
SOV	Solenoid Operated Valve
SRV	Safety Relief Valve
SSE	Safe Shutdown Earthquake
TRM	Technical Requirements Manual

Section 1: System Description (FSAR level of Detail)

ISG Criteria:

Licensees shall provide a complete description of the system, including important operational characteristics. The level of detail generally considered adequate is consistent with the level of detail contained in the licensee's Final Safety Analysis Report.

Response:

System Overview of the Hardened Containment Vent System (HCVS):

The HCVS will be designed to mitigate a loss-of-decay-heat removal by providing sufficient containment venting capability to limit containment pressurization and to maintain core cooling capability. The vent is designed with sufficient capacity to accommodate decay heat input equivalent to 1% of 3952 MWt which accounts for a 15% planned power uprate above the current licensed thermal power (CLTP). Thus, the hardened vent capacity will be adequate to relieve decay heat for a prolonged station blackout (SBO) event. The HCVS is intended for use as one element of core damage prevention strategies.

The HCVS flow path from the containment to an elevated release point is shown in the simplified diagram below. No ductwork will be used in the flow path.

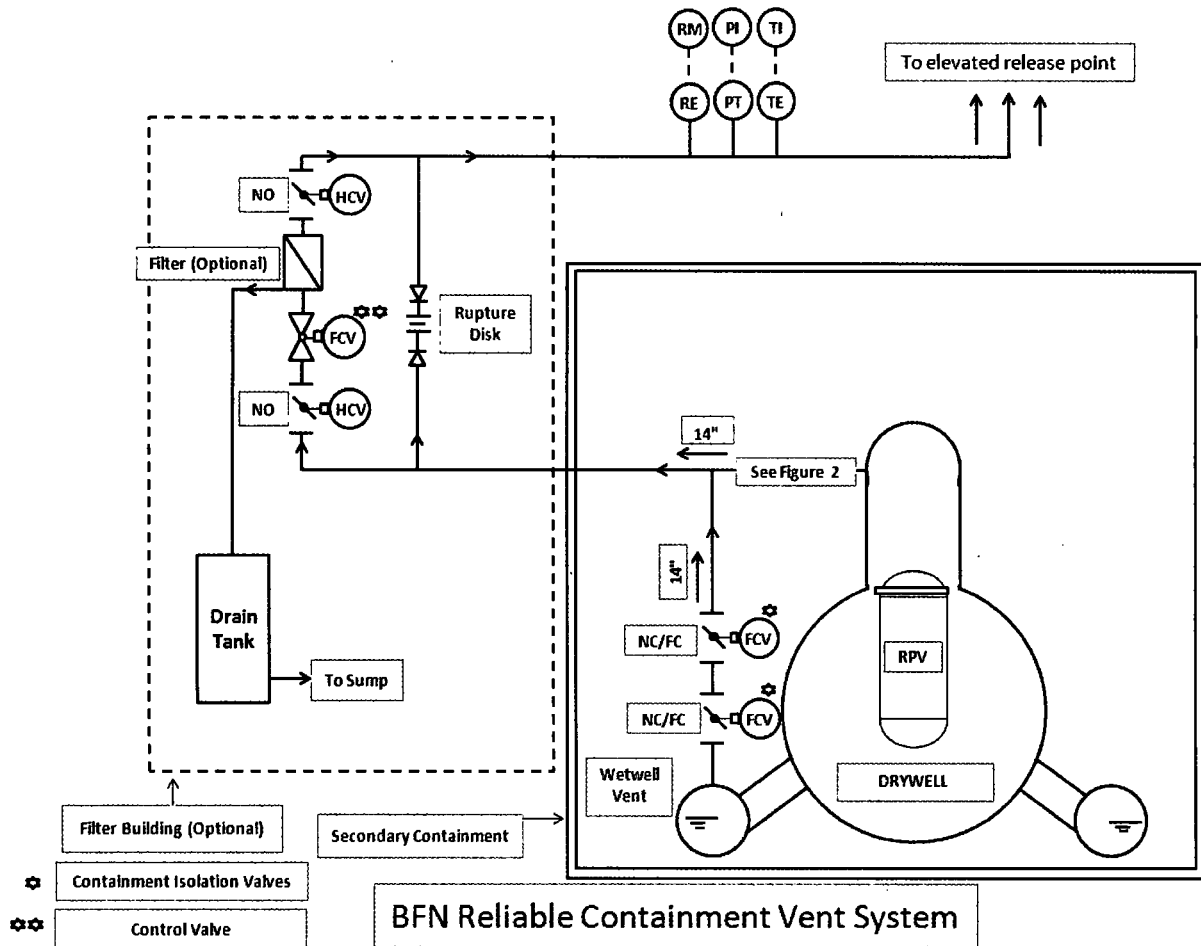

Equipment and components:

The following equipment and components will be provided:

- i. HCVS Mechanical Components –
 - a) Containment isolation piping, valves and controls - The HCVS vent piping and supports up to and including the second containment isolation are designed in accordance with existing design basis. New containment isolation valves for the drywell vent are to be installed in accordance with the plants containment isolation valve design basis. The valves are air-operated valves (AOV)(normally closed, fail closed) with DC powered solenoid valve (SOV) and supplied with an alternative nitrogen motive power source, and can be operated from switches in the Main Control Room or from a remote panel in the Diesel Generator Buildings.
 - b) Other system valves and piping - The HCVS piping and supports downstream of the second containment isolation valve, including valve actuator pneumatic supply components will be designed/analyzed to conform to the requirements consistent with the applicable design codes for the plant and to ensure functionality following a design basis earthquake. A flow control valve, located downstream of the CIV's, will be designed to control the frequency and duration of the venting. The flow control valve will be an AOV (normally closed, failed closed) with a DC power SOV and supplied with an alternative nitrogen motive power source. A drain system will be designed to remove the condensate that would form in the piping after containment venting. The drain system will be located as necessary to remove moisture from components or piping so that the vent path has the ability to perform its design function. The flow valves will be operated from the Main Control Room or from a remote panel in the Diesel Generator Buildings.
 - c) Interface valves provide positive isolation to the interconnected systems. The HCVS wetwell shares part of its flow path with the wetwell air supply purge piping. Prior to initiating the HCVS, confirmation will be made that the corresponding valve (FCV-64-19) is closed. The proposed drywell vent path is planned to be connected to the normal vent path supply to the Standby Gas Treatment (SGTS). Modifications to use the existing Containment Isolation Valve FCV-64-29 and reroute the other CIV's to accommodate a 14" piping tee will be scheduled for completion as denoted in section 6 of this submittal. However, since SGTS isolation valve(s) are AOV(s), with (air-to-open and spring to shut), the containment isolation signal will automatically isolate the valve(s) upon any abnormal high containment pressure.
 - d) Rupture disk(s) will be set to actuate below the containment design pressure, with a capacity to rapidly lower pressure in containment. These components will be installed in the vent line downstream of the CIVs. The Rupture disk will be in parallel with the Flow Control Valve. The Rupture disk will be treated as a passive device that will vent the HCVS downstream of the CIV's as the operating pressure approaches the design pressure of Primary Containment.

As discussed at an NRC Commission Meeting on January 9, 2013, TVA is evaluating potential designs for an optional engineered filter that could potentially be added to the HCVS downstream of the piping as it exits the Reactor Building. An update on TVA's evaluation of a decision to install an engineered filter will be

included in the required six month update. A control valve will be placed in the HCVS line downstream of the CIV's. This control valve will allow the primary containment pressure to be maintained at a desired pressure set point (automatic) or placed in manual control.

Consistent with TVA's ongoing evaluation of engineered filter designs, a filter building will be sized to house a filter designed with the latest advanced technology. The HCVS Flow Control Valve, engineered filter (if decision made to install), rupture disk, and drain tank will be housed in a unit specific filter building. This filter building would be located in the berm on the south side of the associated unit Reactor building. This filter building will be designed to withstand external events and be located above the flood plain or any associated wave runup.

- ii. Instrumentation to monitor the status of the HCVS –
 - a) Instrumentation indications will be available in the Main Control Room and from a remote panel in the Diesel Generator Buildings. The proposed implementation plan shall include Pressure, Temperature, Flow, Radiation monitoring and valve position for all remotely operated valves on each effluent discharge path (1 per unit). The HCVS shall have local readout capability near the instrument sensing location.
 - b) An effluent radiation monitor is located on the outside of the vent line piping downstream of the Rupture disk. The radiation monitor will allow the operator to be informed of the presence of, or the onset of, core damage during HCVS operation. This will allow operations to perform an evaluation of the process conditions and take appropriate actions to revise the venting or core cooling process.
 - c) HCVS vent flow path valves position indication, temperature and pressure instrumentation will monitor the status of the HCVS to aid the operator to ensure verification of proper venting operation. A failure of the position indication instrumentation would not prevent opening and closing the valve.
 - d) Power status and pneumatic pressure indication will also be provided to monitor the status of the HCVS. This will allow the operator to take additional action if the power and/or pneumatic supply were lost.
 - e) Pressure indication for the drywell, wetwell and reactor, along with temperature and level indication for the wetwell, will aid the operator to ensure proper vent operation.
 - f) The instrumentation associated with HCVS is not required to be safety related, but it shall be mounted to support criteria of at least the site design criteria for SSE, and any interface to safety related equipment shall at a minimum meet the support and connection requirements of the safety related equipment.

- iii. Support systems –
 - a) Normal power for the HCVS valve solenoids will be provided from the essential DC batteries source, which is supplied through either battery board 1, 2 or 3 dependent on unit specific configuration
 - b) Back-up power is provided from a permanently installed DC power source (225KVA) and a 3MWe generator that can be connected to the 480V boards for at least 24 hours.
 - c) Motive air/gas supply for HCVS operation will be adequate for at least the first

24 hours during operation under prolonged SBO conditions provided from the nitrogen system.

- d) FLEX equipment will have the capability to provide back-up support equipment for reliable HCVS operation. Power is supplied from either the 3MWe or the 225KVA generator. The FLEX arrangement for supplying power for the HCVS is through the 480V boards. Motive air/gas for HCVS operation is supplied from the Control Air System with Containment Atmospheric Dilution System as a backup for normal operation or design basis events. During a ELAP, motive air power will be supplied from nitrogen tanks. The nitrogen tanks will be automatically set to supply air for the Containment flow control valve. Power for instrumentation is supplied from a Safety Related feed connected to Unit batteries 1 (unit 1), 2 (unit 2), and 3 (unit 3). Upon loss of all AC these batteries will continue to power their loads. When the 225KVA diesel generators are started they will be connected to the chargers for Batteries 1, 2, and 3 so the power to the HCVS instrumentation will be continuously energized throughout the event. If any of the 225KVA generators fail to run, the 225KVA design has provisions for cross tie such that these battery chargers will be available. In addition, the 3MW Diesel Generators also are connected to Divisions 1 and 2 busses which provides diverse methods to energize battery chargers for the Safety Related batteries listed above.

System control:

- i. Active: Control valves and CIVs will be operated in accordance with EOIs to control containment pressure. The HCVS will be designed for multiple open/close cycles under *ELAP* conditions. Controlled venting of containment will begin early in the event and follow industry guidelines. Separate control circuits are provided for the valves that are shared between the Containment Purge System and HCVS for each function. The Containment Purge System control circuit will be used during all design basis operating modes and maintains the ability of the valves to operate (open) for normal operation or automatically close when a containment isolation signal is received.

A second, independent, circuit without any automatic controls will allow the containment isolation valves to be opened regardless of existing containment isolation signals.

- ii. Passive: Inadvertent actuation protection will be provided by rupture disk(s) in the vent line downstream of the CIVs. The rupture disk will be placed in a line parallel to the control valve and optional engineered filter. The CIVs aligned to the wetwell or drywell must be open to permit vent flow through the rupture disk.

Section 2: A description of how the design objectives contained in Order EA-050 Attachment 2, Requirements 1.1.1, 1.1.2, and 1.1.3, are met.

Order EA-050 1.1.1 Requirement:

The HCVS shall be designed to minimize the reliance on operator actions.

ISG 1.1.1 Criteria:

During events that significantly challenge plant operations, individual operators are more prone to human error. In addition, the plant operations staff may be required to implement strategies and/or take many concurrent actions that further places a burden on its personnel. During the prolonged SBO condition at the Fukushima Dai-ichi units, operators faced many significant challenges while attempting to restore numerous plant systems that were necessary to cool the reactor core, including the containment venting systems. The difficulties faced by the operators related to the location of the HCVS valves, ambient temperatures and radiological conditions, loss of all alternating current electrical power, loss of motive force to open the vent valves, and exhausting dc battery power. The NRC staff recognizes that operator actions will be needed to operate the HCVS valves; however, the licensees shall consider design features for the system that will minimize the need and reliance on operator actions to the extent possible during a variety of plant conditions, as further discussed in this ISG.

The HCVS shall be designed to be operated from a control panel located in the main control room or a remote but readily accessible location. The HCVS shall be designed to be fully functional and self sufficient with permanently installed equipment in the plant, without the need for portable equipment or connecting thereto, until such time that additional on-site or off-site personnel and portable equipment become available. The HCVS shall be capable of operating in this mode (i.e., relying on permanently installed equipment) for at least 24 hours during the prolonged SBO, unless a shorter period is justified by the licensee. The HCVS operation in this mode depends on a variety of conditions, such as the cause for the SBO (e.g., seismic event, flood, tornado, high winds), severity of the event, and time required for additional help to reach the plant, move portable equipment into place, and make connections to the HCVS.

When evaluating licensee justification for periods less than 24 hours, the NRC staff will consider the number of actions and the cumulative demand on personnel resources that are needed to maintain HCVS functionality (e.g., installation of portable equipment during the first 24 hours to restore power to the HCVS controls and/or instrumentation) as a result of design limitations. For example, the use of supplemental portable power sources may be acceptable if the supplemental power was readily available, could be quickly and easily moved into place, and installed through the use of pre-engineered quick disconnects, and the necessary human actions were identified along with the time needed to complete those actions. Conversely, supplemental power sources located in an unattended warehouse that require a qualified electrician to temporarily wire into the panel would not be considered acceptable by the staff because its installation requires a series of complex, time-consuming actions in order to achieve a successful outcome. There are similar examples that could apply to mechanical systems, such as pneumatic/compressed air systems.

Response (ref. ISG Item 1.1.1):

The operation of the HCVS will be designed to minimize the reliance on operator actions in response to hazards identified in NEI 12-06, *Diverse and Flexible Coping Strategies (FLEX) Implementation Guide*. Immediate operator actions can be completed by Reactor Operators

and include remote-manual initiation from the HCVS control station. The operator actions required to open a vent path are noted in Table 1:

Operator Actions Necessary to Vent the Containment during an ELAP	
Vent containment with containment pressure below the rupture disc rupture pressure	Vent containment with containment pressure above the rupture disc rupture pressure
1. Align the power supply for the CIV's to DC power	1. Ensure HCVS path is open
2. Close Purge/SGTs isolation valves	2. Monitor radioactive releases
3. Disable interlocks as required	3. Monitor electrical power status, pneumatic pressure and containment / HCVS conditions
4. Ensure HCVS drain path is open	4. Initiate a site evacuation if required
5. Open CIVs from MCR or alternate location	
6. Monitor drywell pressure and temperature	
7. Control drywell pressure and wetwell level by the HCVS control valve to avoid rapid drywell depressurization or wetwell water level	
8. Monitor HCVS process parameters	
9. Monitor electrical power status, pneumatic pressure and containment / HCVS conditions	

Table 1

Remote-manual is defined in this report as a non-automatic power operation of a component and does not require the operator to be at or in close proximity to the component. No other operator actions are required to initiate venting under primary procedural protocol.

The initial venting of Primary Containment will be aligned with the wetwell. As plant conditions change during the ELAP and wetwell water level increases to preclude the vent to become non-functioning, drywell vent will be aligned to allow a flow path for containment to the HCVS and to the plant stack. The selection of the CIV's will be determined based on the HCVS vent alignment.

The HCVS will be designed to allow initiation, control, and monitoring of venting from the Main Control Room (MCR) or from a remote panel in the Diesel Generator Buildings. This location minimizes plant operators' exposure to adverse temperature and radiological conditions and is protected from hazards assumed in NEI 12-06.

Permanently installed power and motive air/gas capability will be available to support operation and monitoring of the HCVS for greater than 24 hours. Permanently installed equipment will supply air and power to HCVS. As described in NEI 12-06, allowance is provided for operator actions to restore power. Staffing studies when completed in response to NRC EA-12-049 will demonstrate that sufficient manpower is available to ensure that supplemental DC control power can be established when supplemental ERO staff is available.

Connections for supplementing electrical power for HCVS will be located in accessible areas with reasonable protection per NEI 12-06 that minimize personnel exposure to adverse conditions following a prolonged SBO and venting. Connections will be pre-engineered to minimize manpower resources.

Order EA-050 1.1.2 Requirement:

The HCVS shall be designed to minimize plant operators' exposure to occupational hazards, such as extreme heat stress, while operating the HCVS system.

ISG 1.1.2 Criteria:

During a prolonged SBO, the drywell, wetwell (torus), and nearby areas in the plant where HCVS components are expected to be located will likely experience an excursion in temperatures due to inadequate containment cooling combined with loss of normal and emergency building ventilation systems. In addition, installed normal and emergency lighting in the plant may not be available. Licensees should take into consideration plant conditions expected to be experienced during applicable beyond design basis external events when locating valves, instrument air supplies, and other components that will be required to safely operate the HCVS system. Components required for manual operation should be placed in areas that are readily accessible to plant operators, and not require additional actions, such as the installation of ladders or temporary scaffolding, to operate the system.

When developing a design strategy, the NRC staff expects licensees to analyze potential plant conditions and use its acquired knowledge of these areas, in terms of how temperatures would react to extended SBO conditions and the lighting that would be available during beyond design basis external events. This knowledge also provides an input to system operating procedures, training, the choice of protective clothing, required tools and equipment, and portable lighting.

Response (ref. ISG Item 1.1.2):

The HCVS design allows initiating and then operating and monitoring the HCVS from the Main Control Room (MCR) or from a remote panel in the Diesel Generator Buildings, which minimizes plant operators' exposure to adverse temperature and radiological conditions.

The HCVS design allows initiating and then operating and monitoring the HCVS from the Main Control Room (MCR) or from a remote panel in the Diesel Generator Buildings, which is protected from hazards assumed in NEI 12-06.

In order to minimize operator exposure to temperature excursions due to the impact of the prolonged SBO (i.e., loss of normal and emergency building ventilation systems and/or containment temperature changes) procedures will not require access to suppression pool (wetwell) area and exposure to extreme occupational hazards for normal and backup operation of electrical and pneumatic systems.

Connections for supplemental equipment needed for sustained operation will be located in accessible areas, protected from severe natural phenomena and minimize exposure to occupational hazards. Tools required for sustained operation, such as portable headlamps or

specific lighting alternatives like flashlights or portable lights and connection specific tooling will be pre-staged in the NEI 12-06 storage locations. Neither temporary ladders nor scaffold are required to access these connections or storage locations.

Order EA-050 1.1.3 Requirement:

The HCVS shall also be designed to minimize radiological consequences that would impede personnel actions needed for event response.

ISG 1.1.3 Criteria:

The design of the HCVS should take into consideration the radiological consequences resulting from the event that could negatively impact event response. During the Fukushima event, personnel actions to manually operate the vent valves were impeded due to the location of the valves in the torus rooms. The HCVS shall be designed to be placed in operation by operator actions at a control panel, located in the main control room or in a remote location. The system shall be designed to function in this mode with permanently installed equipment providing electrical power (e.g., dc power batteries) and valve motive force (e.g., N₂/air cylinders). The system shall be designed to function in this mode for a minimum duration of 24 hours with no operator actions required or credited, other than the system initiating actions at the control panel. Durations of less than 24 hours will be considered if justified by adequate supporting information from the licensee. To ensure continued operation of the HCVS beyond 24 hours, licensees may credit manual actions, such as moving portable equipment to supplement electrical power and valve motive power sources.

In response to Generic Letter (GL) 89-16, a number of facilities with Mark I containments installed vent valves in the torus room, near the drywell, or both. Licensees can continue to use these venting locations or select new locations, provided the requirements of this guidance document are satisfied. The HCVS improves the chances of core cooling by removing heat from containment and lowering containment pressure, when core cooling is provided by other systems. If core cooling were to fail and result in the onset core damage, closure of the vent valves may become necessary if the system was not designed for severe accident service. In addition, leakage from the HCVS within the plant and the location of the external release from the HCVS could impact the event response from on-site operators and off-site help arriving at the plant. An adequate strategy to minimize radiological consequences that could impede personnel actions should include the following:

- 1. Licensees shall provide permanent radiation shielding where necessary to facilitate personnel access to valves and allow manual operation of the valves locally. Licensee may use alternatives such as providing features to facilitate manual operation of valves from remote locations, as discussed further in this guidance under Requirement 1.2.2, or relocate the vent valves to areas that are significantly less challenging to operator access/actions.*
- 2. In accordance with Requirement 1.2.8, the HCVS shall be designed for pressures that are consistent with the higher of the primary containment design pressure and the primary containment pressure limit (PCPL), as well as including dynamic loading resulting from system actuation. In addition, the system shall be leak-tight. As such, ventilation duct work (i.e., sheet metal) shall not be utilized in the design of the HCVS. Licensees should perform appropriate testing, such as hydrostatic or pneumatic testing, to establish the leak-tightness of the HCVS.*

3. *The HCVS release to outside atmosphere shall be at an elevation higher than adjacent plant structures. Release through existing plant stacks is considered acceptable, provided the guidance under Requirement 1.2.6 is satisfied. If the release from HCVS is through a vent stack different than the plant stack, the elevation of the stack should be higher than the nearest building or structure.*

Response (ref. ISG Item 1.1.3):

The HCVS will be designed for reliable remote-manual operation. Operators will not be required to access the suppression pool area. The HCVS is designed to minimize system cross flow, prevent steam flow into unintended areas, provide containment isolation, and provide reliable and rugged performance as discussed below for Order requirements 1.2.6.

Dose rates are evaluated consistent with the assumption that the HCVS is to be used for the prevention of core damage. Shielding or other alternatives to facilitate manual actions are not required for operation of the vent under these conditions since no core damage is assumed to have occurred.

Section 3: Operational characteristics and a description of how each of the Order's technical requirements are being met.

Order EA-050 1.2.1 Requirement:

The HCVS shall have the capacity to vent the steam/energy equivalent of 1 percent of licensed/rated thermal power (unless a lower value is justified by analyses); and be able to maintain containment pressure below the primary containment design pressure.

ISG 1.2.1 Criteria:

Beyond design basis external events such as a prolonged SBO could result in the loss of active containment heat removal capability. The primary design objective of the HCVS is to provide sufficient venting capacity to prevent a long-term overpressure failure of the containment by keeping the containment pressure below the primary containment design pressure and the PCPL. The PCPL may be dictated by other factors, such as the maximum containment pressure at which the safety relief valves (SRVs) and the HCVS valves can be opened and closed.

The NRC staff has determined that, for a vent sized under conditions of constant heat input at a rate equal to 1 percent of rated thermal power and containment pressure equal to the lower of the primary containment design pressure and the PCPL, the exhaust-flow through the vent would be sufficient to prevent the containment pressure from increasing. This determination is based on studies that have shown that the torus suppression capacity is typically sufficient to absorb the decay heat generated during at least the first three hours following the shutdown of the reactor with suppression pool as the source of injection, that decay heat is typically less than 1 percent of rated thermal power three hours following shutdown of the reactor, and that decay heat continues to decrease to well under 1 percent, thereafter. Licensees shall have an auditable engineering basis for the decay heat absorbing capacity of their suppression pools, selection of venting pressure such that the HCVS will have sufficient venting capacity under such conditions to maintain containment pressure at or below the primary containment design pressure and the PCPL. If required, venting capacity shall be increased to an appropriate level commensurate with the licensee's venting strategy. Licensees may also use a venting capacity sized under conditions of constant heat input at a rate lower than 1 percent of thermal power if it can be justified by analysis that primary containment design pressure and the PCPL would not be exceeded. In cases where plants were granted, have applied, or plan to apply for power uprates, the licensees shall use 1 percent thermal power corresponding to the uprated thermal power. The basis for the venting capacity shall give appropriate consideration of where venting is being performed from (i.e., wetwell or drywell) and the difference in pressure between the drywell and the suppression chamber. Vent sizing for multi-unit sites must take into consideration simultaneous venting from all the units, and ensure that venting on one unit does not negatively impact the ability to vent on the other units.

Response (ref. ISG Item 1.2.1):

The HCVS wetwell or drywell path is designed for venting steam/energy at a nominal capacity of 1% of 3952 MWt thermal power at pressure of 56 psig. This pressure is the lower of the containment design pressure and the PCPL value. The thermal power of 3952 MWt assumes a power uprate of 15% above the currently licensed thermal power of 3458 MWt.

The 1% value assumes that the suppression pool pressure suppression capacity is sufficient to absorb the decay heat generated during the first 3 hours. The vent would then be able to

prevent containment pressure from increasing above the containment design pressure. As part of the detailed design, the duration of suppression pool decay heat absorption will be confirmed.

The HCVS for all three units will be fully independent of each other except for a common vent stack. Analysis will be used to demonstrate that the configuration of the common stack area piping, components and the possibility of different operating pressures will not create a potential adverse impact on one of the Reactor units HCVS vent capabilities.

Order EA-050 1.2.2 Requirement:

The HCVS shall be accessible to plant operators and be capable of remote operation and control, or manual operation, during sustained operations.

ISG 1.2.2 Criteria:

The preferred location for remote operation and control of the HCVS is from the main control room. However, alternate locations to the control room are also acceptable, provided the licensees take into consideration the following:

- 1. Sustained operations mean the ability to open/close the valves multiple times during the event. Licensees shall determine the number of open/close cycles necessary during the first 24 hours of operation and provide supporting basis consistent with the plant-specific containment venting strategy.*
- 2. An assessment of temperature and radiological conditions that operating personnel may encounter both in transit and locally at the controls. Licensee may use alternatives such as providing features to facilitate manual operation of valves from remote locations or relocating/reorienting the valves.*
- 3. All permanently installed HCVS equipment, including any connections required to supplement the HCVS operation during a prolonged SBO (electric power, N2/air) shall be located above the maximum design basis external flood level or protected from the design basis external flood.*
- 4. During a prolonged SBO, manual operation/action may become necessary to operate the HCVS. As demonstrated during the Fukushima event, the valves lost motive force including electric power and pneumatic air supply to the valve operators, and control power to solenoid valves. If direct access and local operation of the valves is not feasible due to temperature or radiological hazards, licensees should include design features to facilitate remote manual operation of the HCVS valves by means such as reach rods, chain links, hand wheels, and portable equipment to provide motive force (e.g., air/N2 bottles, diesel powered compressors, and dc batteries). The connections between the valves and portable equipment should be designed for quick deployment. If a portable motive force (e.g., air or N2 bottles, dc power supplies) is used in the design strategy, licensees shall provide reasonable protection of that equipment consistent with the staff's guidance delineated in JLD-ISG-2012-01 for Order EA-12-049.*
- 5. The design shall preclude the need for operators to move temporary ladders or operate from atop scaffolding to access the HCVS valves or remote operating locations.*

Response (ref. ISG Item 1.2.2):

The HCVS design allows initiating and then operating and monitoring the HCVS from the Main Control Room (MCR) or from a remote panel in the Diesel Generator Buildings. This location is also protected from adverse natural phenomena.

1. The HCVS flow path valves are air-operated valves (AOV) with air-to-open and spring-to-shut. Opening the valves requires energizing a DC powered solenoid operated valve (SOV) and providing motive air/gas. The detailed design will provide a permanently installed DC power source and motive air/gas supply adequate for the first 24 hours. The initial stored motive air/gas will allow for a minimum of five valve operating cycles; however, the detailed design will determine the number of required valve cycles for the first 24-hours and the initial stored motive air/gas will support the required number of valve cycles. Each of the valves that must be opened will be provided with two SOVs arranged such that energizing either SOV from the dedicated DC power supply can open the valve. The SOVs are the only electrical component required for valve functionality that is located inside the area considered not-accessible following a prolonged SBO. The AOVs do not require torque switches or limit switches.
2. An assessment of temperature and radiological conditions that operating personnel may encounter both in transit and locally at the controls will be performed.
3. All permanently installed HCVS equipment, including any connections required to supplement the HCVS operation during a prolonged SBO (electric power, N2/air) will be located in areas reasonably protected from defined hazards from NEI 12-06.
4. All valves required to open the flow path are designed for remote manual operation following a prolonged SBO, i.e., no valve operation via handwheel, reach-rod or similar means that requires close proximity to the valve. Any supplemental connections will be pre-engineered to minimize man-power resources and any needed portable equipment will be reasonably protected from defined hazards from NEI 12-06.
5. Access to the locations described above will not require temporary ladders or scaffolding.

If the design provides any additional design features, add the information. To address a failure of a HCVS valve to open due to a failure of a DC circuit (SOV, etc), the design will provide a contingency for remotely operating the HCVS valve by energizing a back-up SOV from a Safety Related feed connected to Unit batteries 1 (unit 1), 2 (unit 2), and 3 (unit 3). Upon loss of all AC these batteries will continue to power their loads. When the 225KVA diesel generators are started they will be connected to the chargers for Batteries 1, 2, and 3 so the power to the HCVS instrumentation will be continuously energized throughout the event. If any of the 225KVA generators fail to run, the 225KVA design has provisions for cross tie such that these battery chargers will be available. In addition, the 3MW Diesel Generators also are connected to Divisions 1 and 2 busses, which provides diverse methods to energize battery chargers for the Safety Related batteries listed above.

Order EA-050 1.2.3 Requirement:

The HCVS shall include a means to prevent inadvertent actuation.

ISG 1.2.3 Criteria:

The design of the HCVS shall incorporate features, such as control panel key-locked switches, locking systems, rupture discs, or administrative controls to prevent the inadvertent use of the vent valves. The system shall be designed to preclude

inadvertent actuation of the HCVS due to any single active failure. The design should consider general guidelines such as single point vulnerability and spurious operations of any plant installed equipment associated with HCVS.

The objective of the HCVS is to provide sufficient venting of containment and prevent long-term overpressure failure of containment following the loss of active containment heat removal capability or prolonged SBO. However, inadvertent actuation of HCVS due to a design error, equipment malfunction, or operator error during a design basis loss-of-coolant accident (DBLOCA) could have an undesirable effect on the containment accident pressure (CAP) to provide adequate net positive suction head to the emergency core cooling system (ECCS) pumps. Therefore, prevention of inadvertent actuation, while important for all plants, is essential for plants relying on CAP. The licensee submittals on HCVS shall specifically include details on how this issue will be addressed on their individual plants for all situations when CAP credit is required.

Response (ref. ISG Item 1.2.3):

The feature that prevents inadvertent actuation is that the HCVS containment isolation valves are normally closed AOVs, which are air-to-open and spring-to-shut. The DC SOV must be energized to allow the motive air to open the valve. The MCR switch for each of the two in-series valves will meet current requirements. Although the same DC and motive air source will be used, separate control circuits including switches will be used for the two redundant valves to address single point vulnerabilities that may cause the flow path to inadvertently open.

The HCVS uses the Containment Purge System and SGT containment isolation valves for containment isolation. These containment isolation valves are AOVs and they are air-to-open and spring-to-shut. A DC SOV must be energized to allow the motive air to open the valve. Although these valves are shared between the Containment Purge System and the HCVS, separate control circuits are provided to each valve for each function. This can be done by providing a second SOV which is electrically independent of the first SOV and arranging the SOVs so that energizing either SOV will open the valve. Specifically:

- The Containment Purge System control circuit will be used during all “design basis” operating modes including all design basis transients and accidents. The containment isolation signal will automatically de-energize the SOV on this circuit causing the AOVs to shut.
- A second, independent circuit will be used to operate these valves but only following an event that requires operating the HCVS. This circuit will not have any automatic controls including high containment pressure isolation signal, but the HCVS control circuit will have a key-locked switch for each of the two in-series valves to address inadvertent operation. Turning the switch to “open” will energize the second SOV opening the valve. Both valves will use the same DC power for opening in the HCVS function. Separate control circuits, including switches, will be used for the two redundant valves to address single point vulnerabilities that may cause the flow path to inadvertently open.

EOI operating procedures provide clear guidance that the HCVS is not to be used to defeat containment integrity during any design basis transients and accident. In addition, the HCVS will be designed to provide features to prevent inadvertent actuation due to a design error, equipment malfunction, or operator error such that any credited containment accident pressure (CAP) that would provide net positive suction head to the emergency core cooling system (ECCS) pumps will be available (inclusive of a design basis loss-of-coolant accident (DBLOCA)).

Order EA-050 1.2.4 Requirement:

The HCVS shall include a means to monitor the status of the vent system (e.g., valve position indication) from the control room or other location(s). The monitoring system shall be designed for sustained operation during a prolonged SBO.

ISG 1.2.4 Criteria:

Plant operators must be able to readily monitor the status of the HCVS at all times, including being able to understand whether or not containment pressure/energy is being vented through the HCVS, and whether or not containment integrity has been restored following venting operations. Licensees shall provide a means to allow plant operators to readily determine, or have knowledge of, the following system parameters:

- (1) HCVS vent valves' position (open or closed),*
- (2) system pressure, and*
- (3) effluent temperature.*

Other important information includes the status of supporting systems, such as availability of electrical power and pneumatic supply pressure. Monitoring by means of permanently installed gauges that are at, or nearby, the HCVS control panel is acceptable. The staff will consider alternative approaches for system status instrumentation; however, licensees must provide sufficient information and justification for alternative approaches.

The means to monitor system status shall support sustained operations during a prolonged SBO, and be designed to operate under potentially harsh environmental conditions that would be expected following a loss of containment heat removal capability and SBO. Power supplies to all instruments, controls, and indications shall be from the same power sources supporting the HCVS operation. "Sustained operations" may include the use of portable equipment to provide an alternate source of power to components used to monitor HCVS status. Licensees shall demonstrate instrument reliability via an appropriate combination of design, analyses, operating experience, and/or testing of channel components for the following sets of parameters:

- radiological conditions that the instruments may encounter under normal plant conditions, and during and after a prolonged SBO event.*
- temperatures and pressure conditions as described under requirement 1.2.8, including dynamic loading from system operation.*
- humidity based on instrument location and effluent conditions in the HCVS.*

Response (ref. ISG Item 1.2.4):

The design of the HCVS will have temperature and pressure monitoring downstream of the last isolation valve and rupture disc. All flow path valves will have open and closed position indication. These HCVS indications will be at or near the same location as the valve control switches, which is the MCR or from a remote panel in the Diesel Generator Buildings. Motive air/gas pressure and power source voltage will be monitored. The operators will also have instrumentation for the pressure in the drywell, wetwell and reactor, along with temperature and level indication of the wetwell.

Power for the instrumentation will be from the same source used for the SOVs used to position the AOVs. Refer to the response to 1.2.2 for discussion on the power.

The approximate range for the temperature indication will be 50°F to 580°F. The approximate range for the pressure indication will be 0 psig to 130 psig. The upper limits are approximately twice the required design containment temperature and pressure. The ranges will be finalized when the detailed design and equipment specifications are prepared.

The detailed design will address the radiological, temperature, pressure, flow induced vibration (if applicable) and internal piping dynamic forces, humidity/condensation and seismic qualification requirements. Assumed radiological conditions are those expected after a prolonged SBO (without fuel failure), which will bound normal plant conditions.

Order EA-050 1.2.5 Requirement:

The HCVS shall include a means to monitor the effluent discharge for radioactivity that may be released from operation of the HCVS. The monitoring system shall provide indication in the control room or other location(s), and shall be designed for sustained operation during a prolonged SBO.

ISG 1.2.5 Criteria:

Licensees shall provide an independent means to monitor overall radioactivity that may be released from the HCVS discharge. The radiation monitor does not need to meet the requirements of NUREG 0737 for monitored releases, nor does it need to be able monitor releases quantitatively to ensure compliance with Title 10 of the Code of Federal Regulations (10 CFR) Part 100 or 10 CFR Section 50.67. A wide-range monitoring system to monitor the overall activity in the release providing indication that effluent from the containment environment that is passing by the monitor is acceptable. The use of other existing radiation monitoring capability in lieu of an independent HCVS radiation monitor is not acceptable because plant operators need accurate information about releases coming from the containment via the HCVS in order to make informed decisions on operation of the reliable hardened venting system.

The monitoring system shall provide indication in the control room or a remote location (i.e., HCVS control panel) for the first 24 hours of an extended SBO with electric power provided by permanent DC battery sources, and supplemented by portable power sources for sustained operations. Monitoring radiation levels is required only during the events that necessitate operation of the HCVS. The reliability of the effluent monitoring system under the applicable environmental conditions shall be demonstrated by methods described under Requirement 1.2.4.

Response (ref. ISG Item 1.2.5):

The HCVS radiation monitoring system (RMS) will be dedicated to the HCVS. The approximate range of the RMS will be designed to allow a sufficient range of operation to monitor the effluent. This range is considered adequate to determine core integrity per the NRC Responses to Public Comments document.

The detector will be physically mounted on the outside of the piping, accounting for the pipe wall thickness shielding in order to provide a measurement of the radiation level on the inside of the HCVS piping. The radiation level will be indicated at the MCR or from a remote panel in the Diesel Generator Buildings. The RMS will be powered from the same source as all other powered HCVS components. Refer to the response to 1.2.2 for discussion on sustainability of the power.

Order EA-050 1.2.6 Requirement:

The HCVS shall include design features to minimize unintended cross flow of vented fluids within a unit and between units on the site.

ISG 1.2.6 Criteria:

At Fukushima, an explosion occurred in Unit 4, which was in a maintenance outage at the time of the event. Although the facts have not been fully established, a likely cause of the explosion in Unit 4 is that hydrogen leaked from Unit 3 to Unit 4 through a common venting system. System cross-connections present a potential for steam, hydrogen, and airborne radioactivity leakage to other areas of the plant and to adjacent units at multi-unit sites if the units are equipped with common vent piping. In this context, a design that is free of physical and control interfaces with other systems eliminates the potential for any cross-flow and is one way to satisfy this requirement. Regardless, system design shall provide design features to prevent the cross flow of vented fluids and migration to other areas within the plant or to adjacent units at multi-unit sites.

The current design of the hardened vent at several plants in the U.S. includes cross connections with the standby gas treatment system, which contains sheet metal ducts and filter and fan housings that are not as leak tight as hard pipes. In addition, dual unit plant sites are often equipped with a common plant stack. Examples of acceptable means for prevention of cross flow is by valves, leak-tight dampers, and check valves, which shall be designed to automatically close upon the initiation of the HCVS and shall remain closed for as long as the HCVS is in operation. Licensee's shall evaluate the environmental conditions (e.g. pressure, temperature) at the damper locations during venting operations to ensure that the dampers will remain functional and sufficiently leak-tight, and if necessary, replace the dampers with other suitable equipment such as valves. If power is required for the interfacing valves to move to isolation position, it shall be from the same power sources as the vent valves. Leak tightness of any such barriers shall be periodically verified by testing as described under Requirement 1.2.7.

Response (ref. ISG Item 1.2.6):

The HCVS for all three units will be fully independent of each other except for a common vent stack. Analysis will be used to demonstrate that the configuration of the common stack area piping, components and the possibility of different operating pressures will not create a potential adverse impact on one of the Reactor units HCVS vent capabilities.

The drywell portion of the HCVS shares part of its flowpath with the Standby Gas Treatment System (SGTS). Prior to initiating the HCVS, the valve to the SGTS must be isolated. However, since SGTS isolation valve(s) are AOV(s), with air-to-open and spring to shut, the containment isolation signal will automatically isolate the valve(s) upon any abnormal containment pressure. The detailed design phase will review the valve(s) to determine if the inter-system valves can meet the required leakage criteria under the limiting HCVS design conditions. If required, the valve(s) will be replaced or upgraded.

Order EA-050 1.2.7 Requirement:

The HCVS shall include features and provision for the operation, testing, inspection and maintenance adequate to ensure that reliable function and capability are maintained.

ISG 1.2.7 Criteria:

The HCVS piping run shall be designed to eliminate the potential for condensation accumulation, as subsequent water hammer could complicate system operation during intermittent venting or to withstand the potential for water hammer without compromising the functionality of the system. Licensees shall provide a means (e.g., drain valves, pressure and temperature gauge connections) to periodically test system components, including exercising (opening and closing) the vent valve(s). In situations where total elimination of condensation is not feasible, HCVS shall be designed to accommodate condensation, including applicable water hammer loads.

The HCVS outboard of the containment boundary shall be tested to ensure that vent flow is released to the outside with minimal leakage, if any, through the interfacing boundaries with other systems or units. Licensees have the option of individually leak testing interfacing valves or testing the overall leakage of the HCVS volume by conventional leak rate testing methods. The test volume shall envelope the HCVS between the outer primary containment isolation barrier and the vent exiting the plant buildings, including the volume up to the interfacing valves. The test pressure shall be based on the HCVS design pressure. Permissible leakage rates for the interfacing valves shall be within the requirements of American Society of Mechanical Engineers Operation and Maintenance of Nuclear Power Plants Code (ASME OM) – 2009, Subsection ISTC – 3630 (e) (2), or later edition of the ASME OM Code. When testing the HCVS volume, allowed leakage shall not exceed the sum of the interfacing valve leakages as determined from the ASME OM Code. The NRC staff will consider a higher leakage acceptance values if licensees provide acceptable justification. When reviewing such requests, the NRC staff will consider the impact of the leakage on the habitability of the rooms and areas within the building and operability of equipment in these areas during the event response and subsequent recovery periods. Licensees shall implement the following operation, testing and inspection requirements for the HCVS to ensure reliable operation of the system.

Testing and Inspection Requirements

<i>Description</i>	<i>Frequency</i>
<i>Cycle the HCVS valves and the interfacing system valves not used to maintain containment integrity during operations.</i>	<i>Once per year</i>
<i>Perform visual inspections and a walkdown of HCVS components</i>	<i>Once per operating cycle</i>
<i>Test and calibrate the HCVS radiation monitors.</i>	<i>Once per operating cycle</i>
<i>Leak test the HCVS.</i>	<i>(1) Prior to first declaring the system functional; (2) Once every five years thereafter; and (3) After restoration of any breach of system boundary within the buildings</i>
<i>Validate the HCVS operating procedures by conducting an open/close test of the HCVS control logic from its control panel and ensuring that all interfacing system valves move to their proper (intended) positions.</i>	<i>Once per every other operating cycle</i>

Response (ref. ISG Item 1.2.7):

The detailed design for the HCVS will address condensation accumulation resulting from intermittent or continuous controlled venting. A drain tank will be designed to remove water that has accumulated in the HCVS system up to and including the Engineered filter based on TVA's evaluation to install an Engineered filter. In situations where total elimination of condensation is not feasible, the HCVS will be designed to accommodate condensation, including allowance for applicable water hammer loads.

The HCVS Containment Isolation Valves will be tested in accordance with the licensing and design basis for the plant. The HCVS past the outboard Containment Isolation Valve will be tested in conformance to one of the ISG methods. The test pressure shall be based on the HCVS design pressure, 56 psig. Permissible leakage rates for the interfacing valves will be within the requirements of American Society of Mechanical Engineers Operation and Maintenance of Nuclear Power Plants Code (ASME OM) – 2009, Subsection ISTC – 3630 (e) (2), or later edition of the ASME OM Code. When testing the HCVS volume, the allowed leakage will not exceed the sum of the interfacing valve leakages as determined from the ASME OM Code unless a higher leakage acceptance value is justified to the NRC.

The test types and frequencies will conform to the ISG 1.2.7 Table "Testing and inspection Requirements" with the clarification that "Leak test the HCVS" applies to the HCVS boundary valves. Rupture disks will be replaced at manufactures recommendations not to exceed 10 years, per the NRC Responses to Public Comments document.

Order EA-050 1.2.8 Requirement:

The HCVS shall be designed for pressures that are consistent with maximum containment design pressures, as well as, dynamic loading resulting from system actuation.

ISG 1.2.8 Criteria:

The vent system shall be designed for the higher of the primary containment design pressure or PCPL, and a saturation temperature corresponding to the HCVS design pressure. However, if the venting location is from the drywell, an additional margin of 50°F shall be added to the design temperature because of the potential for superheated conditions in the drywell. The piping, valves, and the valve actuators shall be designed to withstand the dynamic loading resulting from the actuation of the system, including piping reaction loads from valve opening, concurrent hydrodynamic loads from SRV discharges to the suppression pool, and potential for water hammer from accumulation of steam condensation during multiple venting cycles.

Response (ref. ISG Item 1.2.8):

The HCVS upstream of the Flow Control valve and rupture disk design pressure is 56 psig and design temperature is 345°F. The HCVS design pressure is higher than both the containment design pressure and the PCPL value. The HCVS design temperature corresponds to the saturation steam temperature at the design pressure plus 50°F to accommodate superheating in the drywell.

The piping, valves, and valve actuators will be designed to withstand the dynamic loading resulting from the actuation of the HCVS, including piping reaction loads from valve opening, concurrent hydrodynamic loads from SRV discharges to the suppression pool, and potential for water hammer from accumulation of condensation during multiple venting cycles.

Order EA-050 1.2.9 Requirement:

The HCVS shall discharge the effluent to a release point above main plant structures.

ISG 1.2.9 Criteria:

The HCVS release to outside atmosphere shall be at an elevation higher than adjacent plant structures. Release through existing plant stacks is considered acceptable, provided the guidance under Requirement 1.2.6 is satisfied. If the release from HCVS is through a stack different than the plant stack, the elevation of the stack should be higher than the nearest building or structure. The release point should be situated away from ventilation system intake and exhaust openings, and emergency response facilities. The release stack or structure exposed to outside shall be designed or protected to withstand missiles that could be generated by the external events causing the prolonged SBO (e.g., tornadoes, high winds).

Response (ref. ISG Item 1.2.9):

The HCVS discharge path uses the plant stack. The detailed design will address missile protection from external events as defined by NEI 12-06 for the outside portions of the selected release stack or structure.

Section 4: Applicable Quality Requirements (Order EA-050 requirements 2.1 and 2.2)

Order EA-050 2.1 Requirement:

The HCVS system design shall not preclude the containment isolation valves, including the vent valve from performing their intended containment isolation function consistent with the design basis for the plant. These items include piping, piping supports, containment isolation valves, containment isolation valve actuators and containment isolation valve position indication components.

ISG 2.1 Criteria:

The HCVS vent path up to and including the second containment isolation barrier shall be designed consistent with the design basis of the plant. These items include piping, piping supports, containment isolation valves, containment isolation valve actuators and containment isolation valve position indication components. The HCVS design, out to and including the second containment isolation barrier, shall meet safety-related requirements consistent with the design basis of the plant. The staff notes that in response to GL 89-16, in many cases, the HCVS vent line connections were made to existing systems. In some cases, the connection was made in between two existing containment isolation valves and in others to the vacuum breaker line. The HCVS system design shall not preclude the containment isolation valves, including the vent valve from performing their intended containment isolation function consistent with the design basis for the plant. The design shall include all necessary overrides of containment isolation signals and other interface system signals to enable the vent valves to open upon initiation of the HCVS from its control panel

Response (ref. ISG Item 2.1):

The HCVS vent path up to and including the second containment isolation piping and supports are designed in accordance with existing design basis. The HCVS system design will not preclude the containment isolation valves, including the vent valve from performing their intended containment isolation function consistent with the design basis for the plant. Associated actuators, position indication, and power supplies are designed consistent with the design basis of the plant as required to maintain their design basis function of maintaining the valves closed. The control circuit will allow operation of the HCVS from its control panel regardless of containment isolation signals.

Order EA-050 2.2 Requirement:

All other HCVS components shall be designed for reliable and rugged performance that is capable of ensuring HCVS functionality following a seismic event. These items include electrical power supply, valve actuator pneumatic supply, and instrumentation (local and remote) components.

ISG 2.2 Criteria:

All components of the HCVS beyond the second containment isolation barrier shall be designed to ensure HCVS functionality following the plant's design basis seismic event. These components include, in addition to the hardened vent pipe, electric power supply, pneumatic supply and instrumentation. The design of power and pneumatic supply lines between the HCVS valves and remote locations (if portable sources were to be employed) shall also be designed to ensure HCVS functionality. Licensees shall ensure that the HCVS will not impact other safety-related structures and components and that the HCVS will not be impacted by non-seismic components. The staff prefers that the

HCVS components, including the piping run, be located in seismically qualified structures. However, short runs of HCVS piping in non-seismic structures are acceptable if the licensee provides adequate justification on the seismic ruggedness of these structures. The hardened vent shall be designed to conform to the requirements consistent with the applicable design codes for the plant, such as the American Society of Mechanical Engineers Boiler and Pressure Vessel Code and the applicable Specifications, Codes and Standards of the American Institute of Steel Construction.

To ensure the functionality of instruments following a seismic event, the NRC staff considers any of the following as acceptable methods:

- Use of instruments and supporting components with known operating principles that are supplied by manufacturers with commercial quality assurance programs, such as ISO9001. The procurement specifications shall include the seismic requirements and/or instrument design requirements, and specify the need for commercial design standards and testing under seismic loadings consistent with design basis values at the instrument locations.*
- Demonstration of the seismic reliability of the instrumentation through methods that predict performance by analysis, qualification testing under simulated seismic conditions, a combination of testing and analysis, or the use of experience data. Guidance for these is based on sections 7, 8, 9, and 10 of IEEE Standard 344-2004, "IEEE Recommended Practice for Seismic Qualification of Class 1E Equipment for Nuclear Power Generating Stations," or a substantially similar industrial standard could be used.*
- Demonstration that the instrumentation is substantially similar in design to instrumentation that has been previously tested to seismic loading levels in accordance with the plant design basis at the location where the instrument is to be installed (g-levels and frequency ranges). Such testing and analysis should be similar to that performed for the plant licensing basis.*

Response (ref. ISG Item 2.2):

The HCVS components downstream of the second containment isolation valve and components that interface with the HCVS are routed in seismically qualified structures or routed underground.

The HCVS downstream of the second containment isolation valve, including piping and supports, electrical power supply, valve actuator pneumatic supply, and instrumentation (local and remote) components, will be designed/analyzed to conform to the requirements consistent with the applicable design codes for the plant and to ensure functionality following a design basis earthquake.

The HCVS instruments, including valve position indication, process instrumentation, radiation monitoring, and support system monitoring, will be qualified by using one of the three methods described in the ISG, which includes:

1. Purchase of instruments and supporting components with known operating principles from manufacturers with commercial quality assurance programs (e.g., ISO9001) where the procurement specifications include the applicable seismic requirements, design requirements, and applicable testing.
2. Demonstration of seismic reliability via methods that predict performance described in IEEE 344-2004

3. Demonstration that instrumentation is substantially similar to the design of instrumentation previously qualified.

<u>Instrument</u>	<u>Qualification Method*</u>
HCVS Process Temperature	ISO9001 / IEEE 344-2004 / Demonstration
HCVS Process Pressure	ISO9001 / IEEE 344-2004 / Demonstration
HCVS Process Radiation Monitor	ISO9001 / IEEE 344-2004 / Demonstration
HCVS Process Valve Position	ISO9001 / IEEE 344-2004 / Demonstration
HCVS Pneumatic Supply Pressure	ISO9001 / IEEE 344-2004 / Demonstration
HCVS Electrical Power Supply Availability	ISO9001 / IEEE 344-2004 / Demonstration

* The specific qualification method used for each required HCVS instrument will be reported in future 6 month status reports.

Section 5: Procedures and Training (Order EA-050 requirements 3.1 and 3.2)

Order EA-050 3.1 Requirement:

Licensees shall develop, implement, and maintain procedures necessary for the safe operation of the HCVS. Procedures shall be established for system operations when normal and backup power is available, and during SBO conditions.

ISG 3.1 Criteria:

Procedures shall be developed describing when and how to place the HCVS in operation, the location of system components, instrumentation available, normal and backup power supplies, directions for sustained operation, including the storage location of portable equipment, training on operating the portable equipment, and testing of equipment. The procedures shall identify appropriate conditions and criteria for use of the HCVS. The procedures shall clearly state the nexus between CAP and ECCS pumps during a DBLOCA and how an inadvertent opening of the vent valve could have an adverse impact on this nexus. The HCVS procedures shall be developed and implemented in the same manner as other plant procedures necessary to support the execution of the Emergency Operating Instructions (EOIs).

Licensees shall establish provisions for out-of-service requirements of the HCVS and compensatory measures. These provisions shall be documented in the Technical Requirements Manual (TRM) or similar document. The allowed unavailability time for the HCVS shall not exceed 30 days during modes 1, 2, and 3. If the unavailability time exceeds 30 days, the TRM shall direct licensees to perform a cause assessment and take the necessary actions to restore HCVS availability in a timely manner, consistent with plant procedures and prevent future unavailability for similar causes.

Response (ref. ISG Item 3.1):

Procedures will be established for system operations when normal and backup power is available, and during prolonged SBO conditions.

The HCVS procedures will be developed and implemented following the plants process for initiating or revising procedures and contain the following details:

- appropriate conditions and criteria for use of the HCVS
- when and how to place the HCVS in operation,
- the location of system components,
- instrumentation available,
- normal and backup power supplies,
- directions for sustained operation(reference NEI 12-06), including the storage location of portable equipment,
- training on operating the portable equipment, and
- testing of portable equipment

Licensees will establish provisions for out-of-service requirements of the HCVS and compensatory measures. The following provisions will be documented in the Technical Requirements Manual (TRM) or other similar documents:

- The allowed unavailability time for the HCVS shall not exceed 30 days during modes 1, 2, and 3.
- If the unavailability time exceeds 30 days
 - The condition will be entered into the corrective action system;

- The HCVS availability will be restored in a manner consistent with plant procedures;
- A cause assessment will be performed to prevent future unavailability for similar causes.

Order EA-050 3.2 Requirement:

Licensee shall train appropriate personnel in the use of the HCVS. The training curricula shall include system operations when normal and backup power is available, and during SBO conditions.

ISG 3.2 Criteria:

All personnel expected to operate the HVCS shall receive training in the use of plant procedures developed for system operations when normal and backup power is available, and during SBO conditions consistent with the plants systematic approach to training. The training shall be refreshed on a periodic basis and as any changes occur to the HCVS.

Response (ref. ISG Item 3.2):

Personnel expected to perform direct execution of the HVCS will receive necessary training in the use of plant procedures for system operations when normal and backup power is available and during prolonged SBO conditions. The training will be refreshed on a periodic basis and as any changes occur to the HCVS. The training will utilize the systematic approach to training.

In addition, per NEI 12-06, all personnel on-site will be available to supplement trained personnel.

Section 6: Implementation Schedule Milestones

The following milestone schedule is provided. The dates are planning dates subject to change as design and implementation details are developed. Any changes to the following target dates will be reflected in the subsequent 6 month status reports.

Original Target Date	Activity	Status
Oct. 2012	Hold preliminary/conceptual design meeting	Complete
Oct. 2012	Submit 60 Day Status Report	Complete
Feb. 2013	Submit Overall Integrated Implementation Plan	Complete
Aug 2013	Submit 6 Month Status Report	<i>{Include date changes in this column}</i>
Feb. 2014	Submit 6 Month Status Report	
June 2014	U2 Design Change Package Issued	
Aug. 2014	Submit 6 Month Status Report	
Sept. 2014	Procedure Changes Training Material Complete	
Oct 2014	U2 Design Major Material On-site ¹	
Feb. 2015	Submit 6 Month Status Report	
April 2015	U2 Design Change Implemented	
April 2015	U2 Demonstration/Functional Test	
April 2015	Procedure Changes Active for Unit 2	
May 2015	U3 Design Change Package Issued	
Aug. 2015	Submit 6 Month Status Report	
Aug. 2015	U3 Design Major Material On-site	
Aug. 2015	U1 Design Major Material On-site	
Dec. 2015	U1 Design Change Package Issued from Design	
Feb. 2016	Submit 6 Month Status Report	
April 2016	U3 Design Change Implemented	
April. 2016	U3 Demonstration/Functional Test	
April 2016	Procedure Changes Active for Unit 3	
Aug. 2016	Submit 6 Month Status Report	
Nov 2016	U1 Design Change Implemented	
Nov. 2016	U1 Demonstration/Functional Test	
Nov 2016	Procedure Changes Active for Unit 1	
Dec 2016	Submit Completion Report	

¹ Major Equipment - Piping, valves and components greater than 3", Instrumentation pick-ups and indicators.

Section 7: Changes/Updates to this Overall Integrated Implementation Plan

Any significant changes to this plan will be communicated to the NRC staff in the 6 Month Status Reports

Section 8: Figures/Diagrams

ISG IV.C. 1. Reporting Requirements:

A piping and instrumentation diagram or a similar diagram that shows system components and interfaces with plant systems and structures is acceptable.

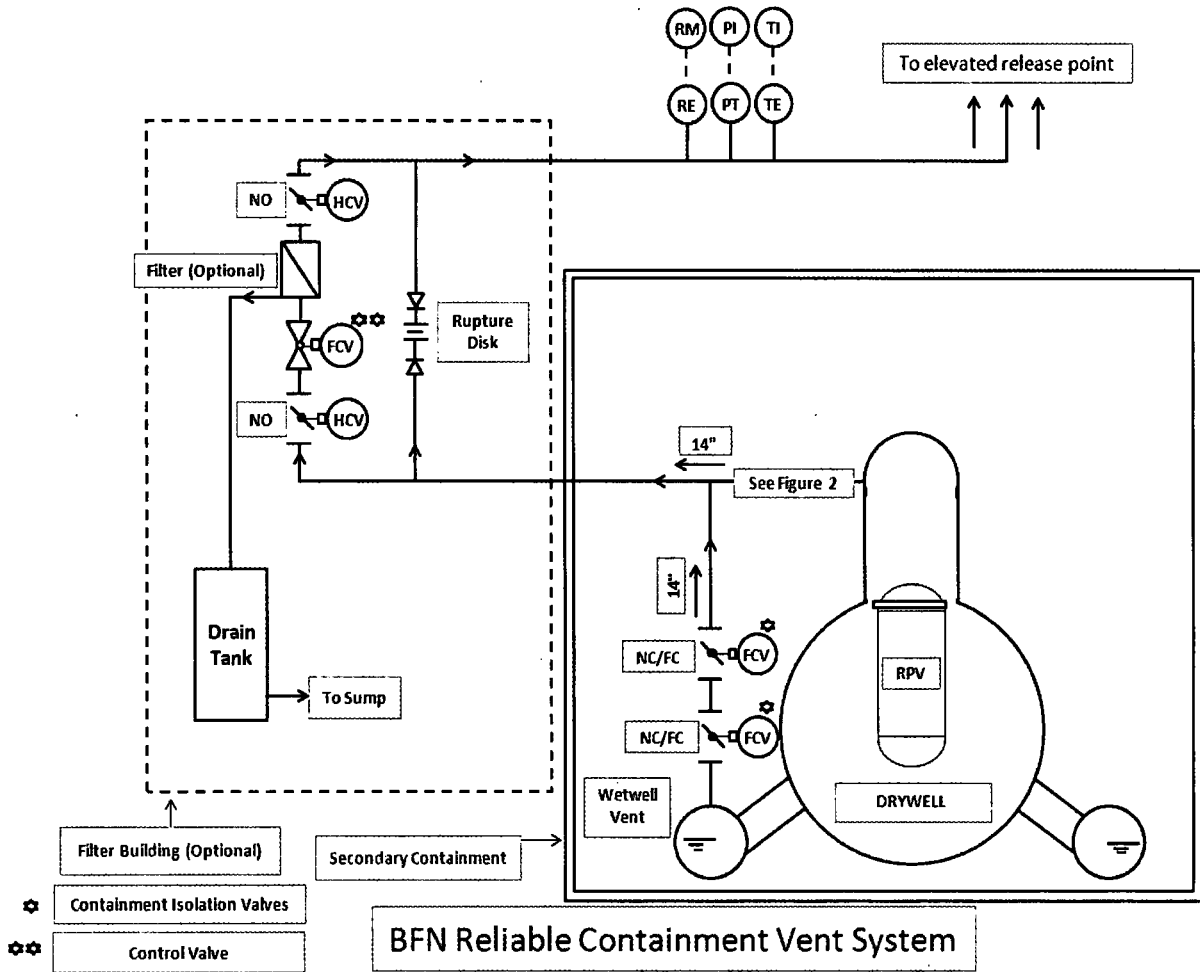

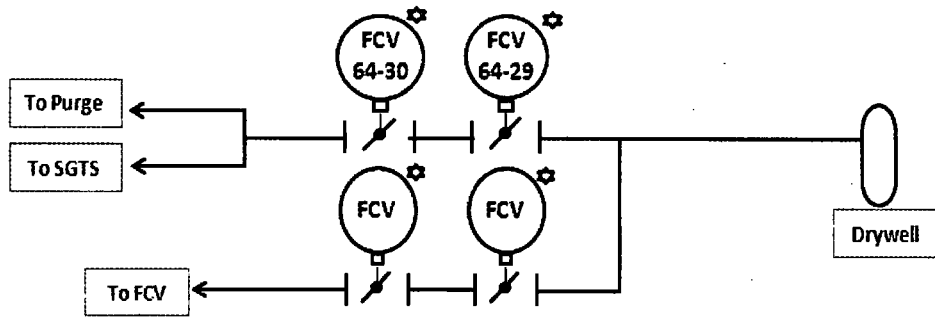

⚙ Containment Isolation Valves

Figure 2 - Drywell Head Vent Detail

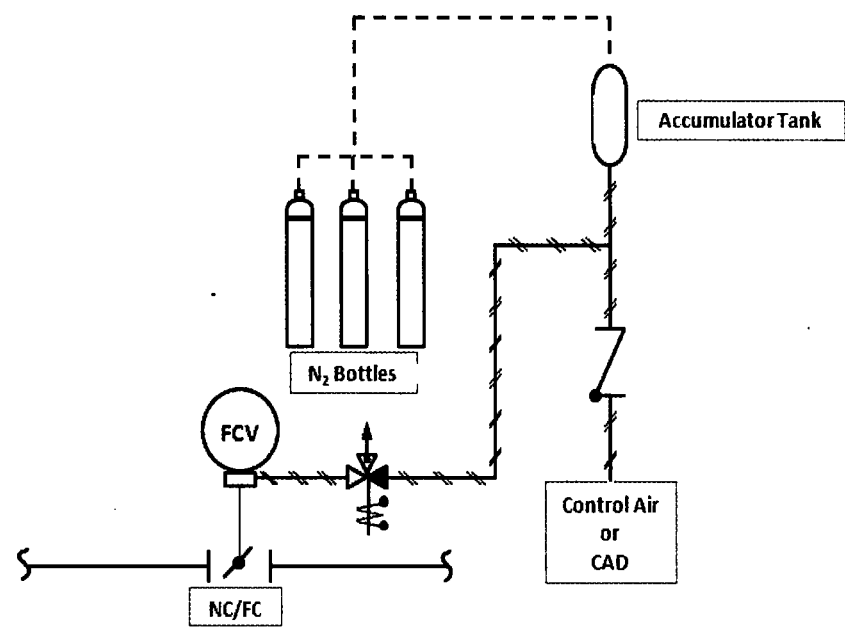

Figure 3 - Typical CIV/FCV Actuator Supply