



RS-13-052

10 CFR 50.55a

February 8, 2013

U.S. Nuclear Regulatory Commission
ATTN: Document Control Desk
Washington, DC 20555-0001

Clinton Power Station, Unit 1
Facility Operating License No. NPF-62
NRC Docket No. 50-461

Subject: Additional Information Regarding Relief Request I3R-09, Alternative to VT-2
Visual Inspection of Combustible Gas Control System Piping

- References:
1. Letter from D. M. Gullott (Exelon Generation Company, LLC) to U.S. NRC, "Relief Request Associated with the Third Inservice Inspection Interval," dated August 23, 2012
 2. Letter from J. S. Wiebe (U.S. NRC) to M. J. Pacilio (Exelon Generation Company, LLC), "Clinton Power Station, Unit No.1 - Request For Additional Information Regarding Relief Request I3R-09, Alternative to VT-2 Visual Inspection of Combustible Gas Control System Piping (TAC NO. ME9428)," dated January 29, 2013

In Reference 1, Exelon Generation Company, LLC (EGC) requested NRC approval of a relief request associated with the third 10-year inservice testing (IST) program interval for Clinton Power Station (CPS). Specifically, Reference 1 requested approval of an alternative to the performance of VT-2 visual inspections for Combustible Gas Control system piping. In Reference 2, the NRC requested additional information that is needed to complete review of relief request I3R-09. In response to this request, EGC is providing the attached information.

There are no regulatory commitments contained in this letter. Should you have any questions concerning this letter, please contact Mr. Thomas J. Griffith at (630) 657-2818.

Respectfully,

Patrick R. Simpson
Manager – Licensing

Attachments:

1. Response to Request for Additional Information
2. Referenced Procedure

cc: NRC Regional Administrator, Region III
NRC Senior Resident Inspector, Clinton Power Station

Attachment 1
Response to Request for Additional Information

Attachment 1
Response to Request for Additional Information

NRC Request 1

When is the scheduled end of the CPS third 10-year inservice inspection interval?

Response

The third 10-year inservice inspection interval, at Clinton Power Station, is currently scheduled to end on June 30, 2020.

NRC Request 2

The column "Pressure Drop Test Duration" in the Table of the proposed alternative might imply that the LLRT is a pressure decay test. Is the LLRT a flow test or is it a pressure decay test? Provide a brief description of the LLRT surveillance procedure CPS 9861.02.

Response

This test is a flow test and, as described in CPS 9861.02, there are three 'test sets' for each train of the hydrogen recombiner subsystems (i.e., train 'A' and train 'B') in the Combustible Gas Control (HG) system. The three test sets for each of the respective subsystems are as follows:

- Test set A, for the 'A' Hydrogen Recombiner train, tests piping and components on the inlet line from the open-ended piping in the containment to motor-operated containment isolation valve 1HG001.
- Test set A, for the 'B' Hydrogen Recombiner train, tests piping and components on the outlet line from the open-ended piping in the containment to motor-operated containment isolation valve 1HG008.
- Test set B, for the 'A' train, tests piping and components on the outlet line from motor-operated containment isolation valve 1HG004 to the open-ended piping in the containment.
- Test set B, for the 'B' train, tests piping and components on the inlet line from motor-operated containment isolation valve 1HG005 to the open-ended piping in the containment.
- Test set C for both trains tests piping and components on the inlet and outlet lines from the open-ended inlet piping in the containment, through the respective hydrogen recombiner (i.e., 0HG01SA or 0HG01SB) to the open-ended outlet piping in the containment, respectively.

Test procedure 9861.02 (i.e., CPS 9861.02D033 and CPS 9861.02D041) is included, as Attachment 2, to this letter.

Attachment 1
Response to Request for Additional Information

NRC Request 2a

If a flow test is being proposed where gas flow rate into the pressurized test volume is measured, what are the pressure stability limits and flow rate stability limits during the test? What is the measurement accuracy of the pressure and flow instrumentation?

Response

Surveillance procedure CPS 9861.02 defines the pressure stability limits during the test as 9.1 psig and 9.9 psig. Furthermore, it defines the flow rate stability limits for these specific tests as less than 1000 standard cubic centimeters per minute (sccm) for train 'A' and less than 500 sccm for train 'B'. The accuracy of the pressure measuring instrumentation is ± 0.15 psig and the accuracy of the flow measuring instrumentation is $\pm 2\%$ of full scale. A copy of CPS 9861.02 has been included in Attachment 2.

NRC Request 2b

If a pressure decay test is being proposed where the test volume pressure decay is monitored while the test volume is isolated and since the volume of the lines and components is relatively large, what is the sensitivity of the test? How is the leakage rate determined from the pressure decay test? What is the instrumentation measurement accuracy?

Response

A pressure decay test is not being proposed.

Attachment 1
Response to Request for Additional Information

NRC Request 3

Provide a brief description of the procedure used for differentiating in-line leakage of valves from through-wall leakage using Test Sets A, B, and C.

Response

A VT-2 qualified individual will observe troubleshooting actions described below using snoop. If flow rates above any administrative limit are obtained, troubleshooting actions would typically include, but are not limited to the following:

- Verifying the test set lineup is correct,
- Snoop the test rig with a soap bubble solution to locate leakage,
- Snoop the mechanical joints in a test boundary (bolted flanges, packing glands, test connections, etc.), using a soap bubble solution to locate leakage,
- Snoop the affected pressure boundary as needed using a soap bubble solution to locate leakage,
- Unacceptable results from test sets A or B may be explained by test set C results, since test set C eliminates seat leakage through the affected motor-operated containment isolation valve. The results from test set C of a train can be compared to the results of test sets A or B of that train to determine if the excessive leakage is due to seat leakage through the motor-operated containment isolation valve.
- If excessive seat leakage through a valve is identified, appropriate maintenance activities may be performed to reduce or eliminate leakage through the affected valve,
- If needed, repair or replacement of any unacceptable indications may be performed, and
- If needed, the affected valve may be repaired or replaced.

If corrections have been made, the affected test set(s) will be re-performed.

Attachment 1
Response to Request for Additional Information

NRC Request 4

The LLRT administrative limits of 1000 standard cubic centimeters per minute (sccm) for Train 'A' and 500 sccm for Train 'B' are significantly below the overall secondary containment bypass limit of 28,882 sccm, but are significantly above the practical leak test sensitivity of a VT-2 examination using a soap solution. What is the technical basis for these LLRT administrative limits?

Response

The proposed administrative limits are based upon engineering judgment. These limits are considered appropriate screening criteria to initiate more detailed evaluations and/or troubleshooting, to identify potential through-wall leakage and to prevent the secondary containment bypass limit (i.e., 28,882 sccm) from being challenged.

NRC Request 5

The proposed alternative specifically requires ASME Code-compliant repair or replacement of safety-related components in which through-wall leakage is found, but does not address repair or replacement of components that are nonsafety-related. If a leak in a pressure boundary that is nonsafety-related were detected during performance of an ASME Code-compliant VT-2 examination, would the nonsafety-related component or piping be repaired or replaced in accordance with the applicable ASME Code requirements? Discuss the disposition of such a leak if it is detected as the result of the LLRT.

Response

Piping and components included in the pressure boundary affected by these tests are Class 2 ASME Code safety-related piping and components. Therefore, there are no nonsafety-related components or piping within the scope of the tests.

Attachment 1
Response to Request for Additional Information

NRC Request 6

Has there been a history of degradation or leakage of the subject piping at CPS? What was the cause of any degradation or leakage?

Response

There has been no degradation trend identified from test results. However, based upon a review of the 62 previous tests performed, four results were obtained that were above the current administrative limits:

- 1080 sccm on train 'B', test set B in 1998,
- 1080 sccm on train 'B', test set B in 1999,
- 552 sccm on train 'B', test set C in 1997, and
- 1250 sccm on train 'A', test set A in 1991.

In the each of the cases mentioned, the test results were included in the overall secondary containment bypass leakage as required, evaluated against the overall secondary containment bypass limit and found to be acceptable. The cause for the leakage in the cases mentioned above was not evaluated because the administrative limit in place at the time of the tests (i.e., 20,000 sccm) was not exceeded.

Attachment 2
Referenced Procedure

LLRT DATA SHEET FOR 1MC062/1MC166 - HYDROGEN RECOMBINER 1SB

SCOPE OF REVISION:

- Incorporated specific changes 23a - 23e; rev marks not retained.
- IR 1392302
Add new evaluation and troubleshooting requirements for the Pressure Test Program Engineer immediately upon determination that a test set exceeds the administrative limit to comply with Relief Request I3R-09.

CONTINUOUS USE

ORIGINATOR: *HD Jeans*CLASS CODE: *SNNII*SQR: *Lee Anderson*APPROVAL DATE: *02/06/2013***CURRENT CHANGES TO GENERAL REVISION**

Change #	Date	List of Affected Pages
①	_____	_____
②	_____	_____
③	_____	_____
④	_____	_____
⑤	_____	_____

INITIAL

1.0

PURPOSE

The purpose of this test is to perform a 9.1 (-0, +.8) psig air test on Penetration 1MC062/1MC166. The components/valves to be tested are: 1HG008, 1HG019, 1HG005, 1HG018 and Closed Loop

5.0

PREREQUISITES

5.1

In conjunction with SMgmt, review the following impact statements to determine required plant status to perform this test:

TECH SPEC FUNCTIONS IMPACTED

ITS	3.6.1.1	PRIMARY CONTAINMENT
ITS	3.6.1.3	PRIMARY CONTAINMENT ISOLATION VALVES
ITS	3.6.1.3.8	SECONDARY CONTAINMENT BYPASS LEAKAGE
ORM	2.4.10	PRIMARY CONTAINMENT HYDROGEN RECOMBINERS

RPS TRIP - NACRVICS ISOLATION - NALOGIC TYPE - NAMINIMUM OPERABLE CHANNELS -NAPLANT/SYSTEM CONDITIONS REQUIRED TO CONDUCT THIS TEST -

All Modes

Hydrogen Recombiner 0HG01SB secured.

No movement of recently irradiated fuel assemblies in the primary or secondary containment.

No operation with a potential for draining the reactor vessel (OPDRVs).

OTHER SYSTEM AFFECTED - NoneOTHER CHANNELS REQUIRED OPERABLE TO PREVENT INADVERTENT ACTUATION - NASMgmtPERFORMER

5.2

Obtain the Shift/Assistant Shift Supervisor's permission to perform the surveillance.

DATE / TIMESMgmt

- 5.3 Place control switch for OHG01SB, CGCS RECOMB 2, to LOCKOUT. _____
- 5.4 Install test flanges and (or) plugs at on 1MC-062 and 1MC-166 open ended flange connections as follows (Mechanical Maintenance support may be required):
- 5.4.1 Notify the CRO/ASST.SS of installation of test flanges and (or) plugs. _____
- 5.4.2 Install a test flange and (or) plug on line 1HG03A (1MC-166). (CV) _____ / _____
- 5.4.3 Install a test flange and (or) plug on line 1HG04B (1MC-062). (CV) _____ / _____

7.0 **MATERIALS AND/OR TEST EQUIPMENT**

TEST EQUIPT	EIN	RANGE	TOLERANCE	CAL DUE
Flowmeter				
Flowmeter				
Flowmeter				
Press Gauge				
Press Gauge				

8.0 **PROCEDURE**

- ☞ The following abbreviations are used throughout the procedure:
 (RC) = remove cap (TC) = test connection
 (TV) = test vent
 (TR) = tested in the reverse direction
 (J) = tested valve which shall always be shut by its normal means
- ☞ Section 8.2 may be performed in any order and reperformed as necessary at Test Performer discretion.
- ☞ It is permissible to "NA" any sections which are not performed.

8.1 **System Draining**

None

8.2 **System Testing**8.2.1 **TEST SET A (1HG008, 1HG019)**

8.2.1.1 Position/Check Position the following valves:

a) MCR 1H13-P800

1) Verify 1HG005 and 1HG008 Unit 1 CGCS
Cnmt Isol VLVS are CLOSED (J) _____

2) At AB MCC 1B3-1C (1AP77E), turn breaker
OFF for 1HG008, CONT ISOLATION VALVE _____

3) OPEN 1HG005 by placing the control
switch for 1HG005/1HG008 to TEST. (J) _____

b) Aux Bldg 762'

1) Lock OPEN/Check Locked Open 1HG015,
Cont Return Hdr Isol (Recomb B) _____

2) Lock SHUT/Check Locked Shut 1HG019,
Cont Return Hdr Test Conn (Recomb B) (RC, J) _____

c) Aux Bldg 781' W

1) Lock OPEN/Check Locked open 1HG014
Cont Suct Hdr Isol (Recomb B) (TV) _____

2) Lock SHUT/Check Locked Shut 1HG018,
Cont Suction Hdr Test Conn (Recomb B) (RC, J) _____

8.2.1.2 Lock OPEN/Check Locked Open the following valves,
Cont Bldg 702'

a) 1HG006 H2 Recomb B Suct Isol _____

b) 1HG007 H2 Recomb B Return Isol _____

8.2.1.3 Connect Leak Rate Test Equipment at the test
connection for 1MC-062. _____8.2.1.4 Ensure Test Connection for 1MC-166 is providing
an open vent path. _____

8.2.1.5 Perform LLRT test per CPS 2761.02 LOCAL LEAK RATE TESTING EQUIPMENT.

Data for Test Set A (1HG008, 1HG019)					
Test Medium - Dry Air			Test Type - Flow Rate		
Start Time of Test:					
			Date	Time	
Elapsed Time *		Pressure **		Flow	
0	Min.		Psig		sccm
5	Min.		Psig		sccm
10	Min.		Psig		sccm
15	Min.		Psig		sccm
	Min.		Psig		sccm
	Min.		Psig		sccm
	Min.		Psig		sccm
* Elapsed Time for Test to be 15 Min. Minimum from Stabilization					
** Pressure to be 9.1 psig minimum to 9.9 psig maximum					
Established Flow Start			sccm	<u>+</u>	sccm
Established Flow End			sccm	<u>+</u>	sccm
Maximum Flow Rate			sccm	<u>+</u>	sccm

$$\frac{\text{Max Flow}}{\text{Established Flow}} = \frac{\text{Indicated Flow}}{\text{Tolerance}} + \text{sccm}$$

8.2.1.6 CLOSE 1HG005 by placing the control switch for 1HG005/1HG008 to CLOSE.

8.2.1.7 At AB MCC 1B3-1C (1AP77E), turn breaker ON for 1HG008, CONT ISOLATION VALVE

IV /

8.2.2 TEST SET B (1HG005, 1HG018)

8.2.2.1 Position/Check Position the following valves:

a) MCR 1H13-P800

1) Verify 1HG005 and 1HG008 Unit 1 CGCS
Cnmt Isol VLVS are CLOSED (J) _____

2) At AB MCC 1B3-1B (1AP77E), turn breaker
OFF for 1HG005, CONT ISOLATION VALVE _____

3) OPEN 1HG008 by placing the control
switch for 1HG005/1HG008 to TEST. (J) _____

b) Aux Bldg 762'

1) Lock OPEN/Check Locked Open 1HG015
Cont Return Hdr Isol (Recomb B) (TV) _____

2) Lock SHUT/Check Locked Shut 1HG019
Cont Return Hdr Test Conn (Recomb B) (RC, J) _____

c) Aux Bldg 781' W

1) Lock OPEN/Check Locked Open 1HG014
Cont Suct Hdr Isol (Recomb B) _____

2) Lock SHUT/Check Locked Shut 1HG018
Cont Suction Hdr Test Conn (Recomb B) (RC, J) _____

8.2.2.2 Lock OPEN/Check Locked Open the following valves,
Cont Bldg 702'

a) 1HG006 H2 Recomb B Suct Isol _____

b) 1HG007 H2 Recomb B Return Isol _____

8.2.2.3 Connect Leak Rate Test Equipment at the test
connection for 1MC-166. _____8.2.2.4 Ensure Test Connection for 1MC-062 is providing
an open vent path. _____

8.2.2.5 Perform LLRT test per CPS 2761.02, LOCAL LEAK RATE TESTING EQUIPMENT.

Data for Test Set B (1HG005, 1HG018)					
Test Medium - Dry Air			Test Type - Flow Rate		
Start Time of Test:					
		Date		Time	
Elapsed Time *		Pressure **		Flow	
0	Min.		Psig		sccm
5	Min.		Psig		sccm
10	Min.		Psig		sccm
15	Min.		Psig		sccm
	Min.		Psig		sccm
	Min.		Psig		sccm
	Min.		Psig		sccm
* Elapsed Time for Test to be 15 Min. Minimum from Stabilization					
** Pressure to be 9.1 psig minimum to 9.9 psig maximum					
Established Flow Start			sccm	±	sccm
Established Flow End			sccm	±	sccm
Maximum Flow Rate			sccm	±	sccm

$$\frac{\text{Max Flow}}{\text{Established Flow}} = \frac{\text{Indicated Flow}}{\text{Established Flow}} \pm \frac{\text{Tolerance}}{\text{Established Flow}} \text{ sccm}$$

8.2.2.6 CLOSE 1HG008 by placing the control switch for 1HG005/1HG008 to CLOSE.

8.2.2.7 At AB MCC 1B3-1B (1AP77E), turn breaker ON for 1HG005, CONT ISOLATION VALVE

IV /

INITIAL

8.2.3 TEST SET C (Closed Loop)

8.2.3.1 Position/Check Position the following valves:

- a) (MCR 1H13-P800) OPEN/Check Open the following valves by placing their handswitch in TEST.
 - 1) 1HG008 Unit 1 CGCS CNMT Isol (J) _____
 - 2) 1HG005 Unit 1 CGCS CNMT Isol (J) _____
- b) Aux Bldg 762'
 - 1) Lock OPEN/Check Locked Open 1HG015
Cont Return Hdr Isol (Recomb B) _____
 - 2) Lock SHUT/Check Locked Shut 1HG019
Cont Return Hdr Test Conn(Recomb B) (RC,J) _____
- c) Aux Bldg 781' W
 - 1) Lock OPEN/Check Locked Open 1HG014
Cont Suct Hdr Isol (Recomb B) _____
 - 2) Lock SHUT/Check Locked Shut 1HG018
Cont Suction Hdr Test Conn(Recomb B) (RC,J) _____

8.2.3.2 Lock OPEN/Check Locked Open the following valves Control 702

- a) 1HG006 H2 Recomb B Suct Isol _____
- b) 1HG007 H2 Recomb B Return Isol _____

8.2.3.3 Connect Leak Rate Test Equipment at the test connections for 1MC-062 and/or 1MC-166, as desired, by using a tee connection or similar test apparatus as necessary. If connecting to only one test connection, the other test connection will need to be isolated with a cap/plug or flange. _____

8.2.3.4 Perform LLRT test per CPS 2761.02 LOCAL LEAK RATE TESTING EQUIPMENT.

Data for Test Set C Closed Loop					
Test Medium - Dry Air			Test Type - Flow Rate		
Start Time of Test:			Date		
			Time		
Elapsed Time *		Pressure **		Flow	
0	Min.		Psig		sccm
5	Min.		Psig		sccm
10	Min.		Psig		sccm
15	Min.		Psig		sccm
	Min.		Psig		sccm
	Min.		Psig		sccm
	Min.		Psig		sccm
* Elapsed Time for Test to be 15 Min. Minimum from Stabilization					
** Pressure to be 9.1 psig minimum to 9.9 psig maximum					
Established Flow Start			sccm	±	sccm
Established Flow End			sccm	±	sccm
Maximum Flow Rate			sccm	±	sccm

$$\frac{\text{Max Flow}}{\text{Established Flow}} - \frac{\text{Indicated Flow}}{\text{Established Flow}} = \frac{\text{Indicated Flow}}{\text{Established Flow}} \pm \frac{\text{Tolerance}}{\text{Established Flow}} \text{ sccm}$$

8.2.4 Supplemental Test Lineups, if needed, to be added IAW step 8.2.4 of CPS 9861.02.

Additional pages may be added if required.

8.2.4.1 Obtain the Shift/Assistant Shift Supervisor concurrence IAW 8.2.4 of CPS 9861.02. _____

8.2.4.2 Obtain the LLRT Coordinator concurrence IAW 8.2.4 of CPS 9861.02. _____

8.5 **Restoration**

8.5.1 SS/ASST.SS notified of test completion.

(DATE) (TIME) _____

8.5.2 Restore control switch for OHG01SB, CGCS RECOMB 2, to STOP at 1H13-P800.

IV /

8.5.3 Remove the test flanges and (or) plugs from 1HG03A.

IV /

8.5.4 Remove the test flanges and (or) plugs from 1HG04B.

IV /

8.5.5 Notify the CRS of test flange and plug removal.

8.5.6 Reinstall pipe cap on 1HG019

IV /

8.5.7 Reinstall pipe cap on 1HG018

IV /

8.5.8 The system is fully restored from testing using the following valve/electrical lineups:

OR

The system is partially restored due to plant/outage conditions and as directed by the SS/ASST SS. (List partial system status, i.e.: partial lineups performed, tagouts in effect, MCR Log entries as appropriate)

8.5.9 Verify testing equipment removed.

8.5.10 LLRT tags removed if applicable

_____ / _____

_____/_____
SS/ASST.SS Date Restoration Complete

9.0 **ACCEPTANCE CRITERIA**9.1 **Operability Requirements**

9.1.1 This penetration does not have individual leakage limits. The leakage for any containment penetration should not contribute excessively to the overall Type B and Type C leak rate (ITS 3.6.1.1.1) and the Secondary Containment Bypass Leakage Rate (SR 3.6.1.3.8). Leakage is monitored by the Administrative Limit in 9.2.1 and by the NSED App J LLRT Engineer review.

9.2 **Other Requirements**

9.2.1 Administrative Limit: **500** sccm

9.2.1.1 If this limit is exceeded, immediately contact the ISI Pressure Test Program Engineer/Designee to ensure the commitments of Relief Request I3R-09 are met.

9.2.1.2 If this limit is exceeded, initiate an IR and contact the NSED App J LLRT Engineer for evaluation of overall Containment leakage (ITS 3.6.1.1.1) and Secondary Containment Bypass Leakage (SR 3.6.1.3.8).

STEP	Component	Actual Leakage
8.2.1.5	TEST SET A, 1HG008, 1HG019	<u>±</u> sccm
8.2.2.5	TEST SET B, 1HG005, 1HG018	<u>±</u> sccm
8.2.3.4	TEST SET C, Closed Loop	<u>±</u> sccm

An Administrative limit is a leakage limit which is defined in CPS 1305.01 for the purpose of surveillance frequency extension or designated by the NSED Appendix J Coordinator to assist the Test performer in determining acceptability of leakage.

NSED App J LLRT Engineer Actions:

1. Retrieve/obtain previous test results for Comparison to the test results obtained during this test.
2. Compare test results to previous test results. Evaluate trends and initiate further action if required.

9.0 **ACCEPTANCE CRITERIA**9.2 **Other Requirements** (cont'd)

ISI Pressure Test Program Engineer Actions:

1. Evaluate the test results to determine if the leakage is due to through-wall leakage in the pressure boundary. _____
2. Ensure troubleshooting is performed to locate the source of any excessive leakage (as needed). _____
3. Ensure any leakage identified is corrected and the test set is run again. If troubleshooting determines that leakage above the administrative limit may be attributed to a through-wall pressure boundary leak, VT-2 qualified personnel shall perform an examination of the affected area with a leak detection solution. If through-wall pressure boundary leakage is discovered, immediately inform the Shift Management and ensure the component or piping is repaired or replaced in accordance with the applicable ASME Code requirements. _____
4. If evidence of safety-related pressure boundary leakage is not located, the examination will be considered acceptable for ISI Pressure Testing Program requirements for the ISI Period. _____

- 9.2.2 Once the total leakage per Test Set is less than or equal to 500 sccm for Test Sets A,B,and C, the leakage may be considered acceptable and this surveillance may be restored in a routine manner. _____

SUPPLEMENTAL REVIEW SHEET

CORRECTIVE ACTION TAKEN

9.1 OPERABILITY Requirements

ITS LCOs: 3.6.1.3
ORM Ors: 2.4.10 2.5.2
ODCM Ors: None

As applicable:
Initiated Issue Report _____
(yes/no)
Initiated Issue Report (IR) No. _____

9.2 OTHER Requirements

As applicable:
Initiated Issue Report _____
(yes/no)
Initiated Issue Request (IR) No. _____

NOTES/COMMENTS

REVIEW AND APPROVAL

NSED LLRT Coordinator: _____
(Signature) (Date)

Pressure Test Program Manager: _____
(Signature) (Date)

IST Program Coordinator: _____
(Signature) (Date)

Shift Management: _____
(Signature) (Date)

1MC-062 TEST SET A LINEUP

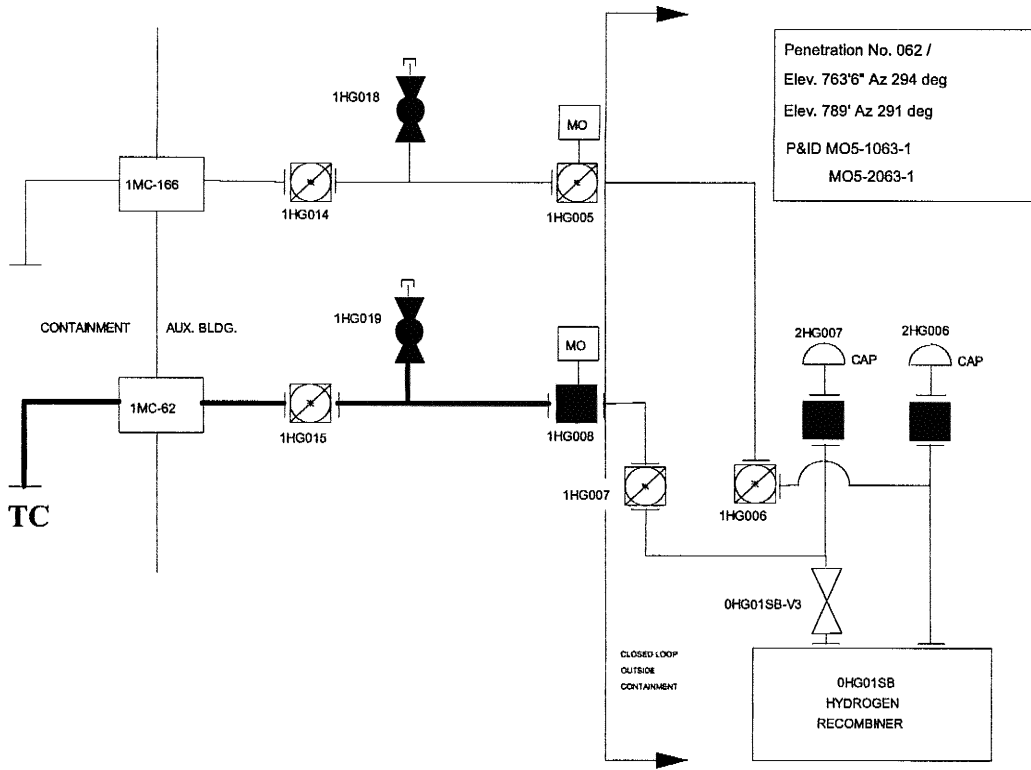

Filled in valves = shut

Test Boundary in Bold

Procedure Step	EIN	Position
8.2.1.1a1	1HG008	Shut (J)
8.2.1.1a3	1HG005	Open (J)
8.2.1.1b1	1HG015	Open
8.2.1.1b2	1HG019	Shut (RC, J)
8.2.1.1c1	1HG014	Open (TV)
8.2.1.1c2	1HG018	Shut (RC, J)
8.2.1.2a	1HG006	Open
8.2.1.2b	1HG007	Open
8.2.1.2c	0HG01SB-V3	Open

1MC-062 TEST SET B LINEUP

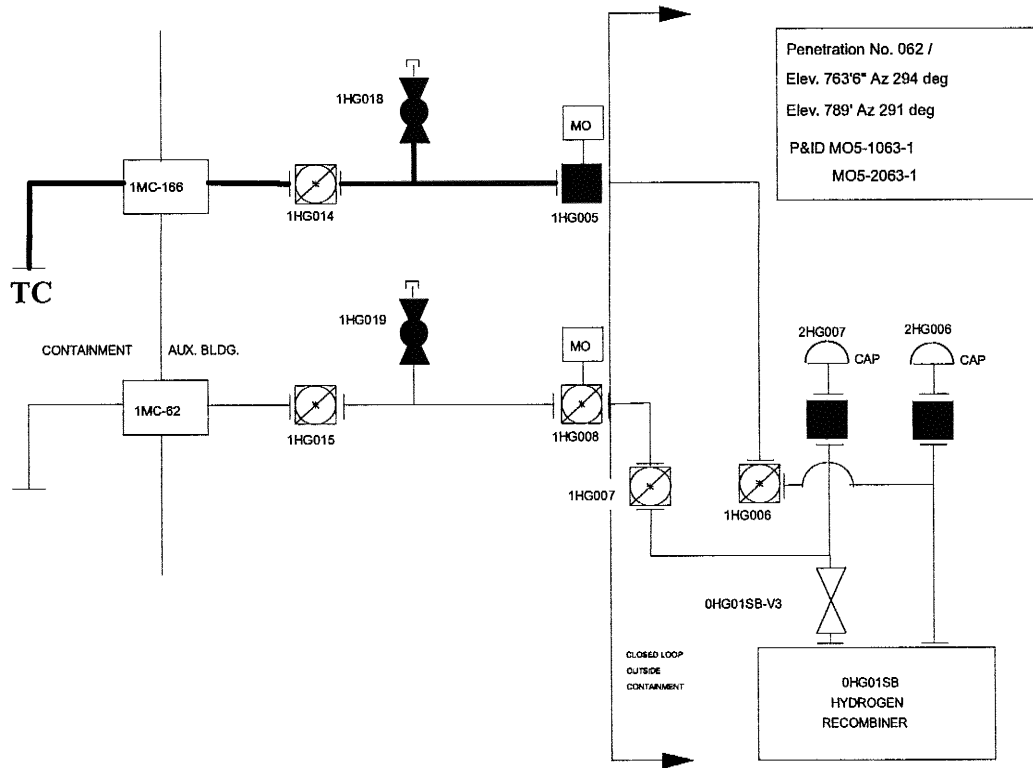

Filled in valves = shut

Test Boundary in Bold

Procedure Step	EIN	Position
8.2.2.1a1	1HG005	Shut (J)
8.2.2.1a3	1HG008	Open (J)
8.2.2.1b1	1HG015	Open (TV)
8.2.2.1b2	1HG019	Shut (RC, J)
8.2.2.1c1	1HG014	Open
8.2.2.1c2	1HG018	Shut (RC, J)
8.2.2.2a	1HG006	Open
8.2.2.2b	1HG007	Open
8.2.2.2c	0HG01SB-V3	Open

1MC-062 TEST SET C LINEUP

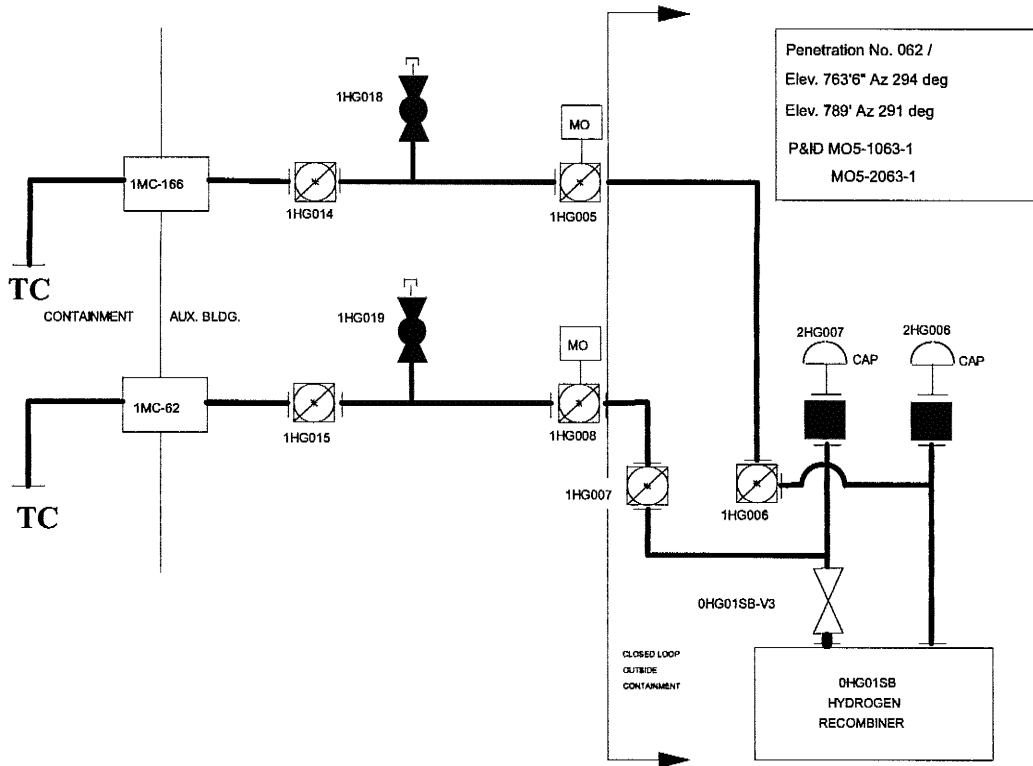

Filled in valves = shut

Test Boundary in Bold

Procedure Step	EIN	Position
8.2.3.1a1	1HG008	Open (J)
8.2.3.1a2	1HG005	Open (J)
8.2.3.1b1	1HG015	Open (TV)
8.2.3.1b2	1HG019	Shut (RC, J)
8.2.3.1c1	1HG014	Open
8.2.3.1c2	1HG018	Shut (RC, J)
8.2.3.2a	1HG006	Open
8.2.3.2b	1HG007	Open
8.2.3.2c	0HG01SB-V3	Open

LLRT DATA SHEET FOR 1MC071 & 1MC072 H2 RECOMBINER

SCOPE OF REVISION:

- Incorporated specific change 23a; rev marks not retained.
- IR 1392302
Add new evaluation and troubleshooting requirements for the Pressure Test Program Engineer immediately upon determination that a test set exceeds the administrative limit to comply with Relief Request I3R-09.

CONTINUOUS USE

ORIGINATOR: *HD Jeans*CLASS CODE: *SNNII*SQR: *Lee Anderson*APPROVAL DATE: *02/06/2013***CURRENT CHANGES TO GENERAL REVISION**

Change #	Date	List of Affected Pages
①	_____	_____
②	_____	_____
③	_____	_____
④	_____	_____
⑤	_____	_____

1.0 The purpose of this test is to perform a 9.1 (-0, +.8) psig air test on Penetrations 1MC071/72. The components/valves to be tested are: 1HG001, 1HG004, 1HG016, 1HG017, Closed Loop.

5.0 **PREREQUISITES**

5.1 In conjunction with the Shift Manager/Control Room Supervisor (SM/CRS), review the following impact statements to determine required plant status to perform this test:

TECH SPEC FUNCTIONS IMPACTED

- ITS 3.6.1.1 PRIMARY CONTAINMENT
- ITS 3.6.1.3 PRIMARY CONTAINMENT ISOLATION VALVES
- ITS 3.6.4.1 SECONDARY CONTAINMENT
- ORM 2.4.10 PRIMARY CONTAINMENT HYDROGEN RECOMBINERS
- ITS SR 3.6.1.3.8 SECONDARY CONTAINMENT BYPASS LEAKAGE

RPS TRIP - N/A

CRVICS ISOLATION - N/A

LOGIC TYPE - N/A

MINIMUM OPERABLE CHANNELS -N/A

PLANT/SYSTEM CONDITIONS REQUIRED TO CONDUCT THIS TEST

Modes 4 or 5

Hydrogen Recombiner 0HG01SA secured.

No movement of recently irradiated fuel assemblies in the primary or secondary containment.

No operation with a potential for draining the reactor vessel (OPDRVs).

OTHER SYSTEMS AFFECTED - N/A

OTHER CHANNELS REQUIRED OPERABLE TO PREVENT INADVERTENT ACTUATION - NA

SM/CRS

Performer

5.2 Obtain the SM/CRS permission to perform the surveillance.

DATE / TIME

SM/CRS

5.3 0HG01SA is secured and disabled.

INITIAL

5.4 Install the test plug/flange:

5.4.1 Notify the RO/CRS of test plug/flanges installation.

5.4.2 Install a test plug/flange on/in lines 1HG01A and 1HG02B. (either 2" Thaxton plugs or 2" 150# flanges with 3/8" tubing connections and temporary gaskets).

CV /

7.0 **MATERIALS AND/OR TEST EQUIPMENT**

TEST EQUIPT	EIN	RANGE	TOLERANCE	CAL DUE
Flowmeter				
Flowmeter				
Flowmeter				
Press Gauge				
Press Gauge				

8.0 **PROCEDURE**

☞ Throughout the procedure the following abbreviations shall be used:

- (RC) = remove cap (TV) = test vent
- (TC) = test connection (DR) = drain valve
- (TR) = tested in the reverse direction
- (J) = tested valve which shall always be shut by its normal means
- (B) = boundary valve
- (SC) = Secondary Containment violation
- (LC) = Locked Closed

☞ Steps within section 8.2 may be performed in any order and reperformed as necessary a test performer discretion, with the following cautions:

- If performing the test sets of section 8.2 out of the normal sequence (i.e., first test A, then test B, etc.), ensure that all valves within the test boundary are positioned appropriately to support the given test set. Not all valve positionings are repeated for each test set. It may be necessary to append the test set lineup (i.e., to open a vent that would normally be opened in a previous test set) using section 8.2.4.
- Test boundary valves should be shut (denoted with a **B**) to prevent inleakage and to bound the test volume prior to positioning other valves within the test boundary. If needed, additional boundary isolation may be provided IAW section 8.2.4.

- ☞ It is permissible to mark any sections or steps N/A which are not performed.
- ☞ "LLRT in Progress" stickers shall be affixed to all affected MCR controls and indications unless instructed otherwise by MCR personnel.
- ☞ It is permissible to "check" valve position via tagout verification.

8.1 NO SYSTEM DRAINING/VENTING REQUIRED

NOTE

Test connections for all three test sets are the test plugs/flanges on lines (1HG01A & 1HG02B), located inside the Cmnt wall above the Suppression Pool. These tests all require erection of scaffolding above the Suppression Pool.

Place System in safe condition for testing, and ensure all affected MCR controls & indications are identified by "LLRT IN PROGRESS" stickers. _____

The system is now ready to perform Test Sets A/B/C. _____

8.2 SYSTEM TESTING

8.2.1 TEST SET A (1HG016, 1HG001)

- 8.2.1.1 Connect leak rate test equipment at the end of line 1HG01A. **(TC)** _____
- 8.2.1.2 Shut 1HG001 and Open 1HG004 by performing the following in order at 1H13-P800 & AB MCC 1A3:
 - a) Notify the MCR about repositioning breakers. _____
 - b) Place the handswitch for 1HG001/1HG004 in the Open position. _____
 - c) Energize/Verify Energized the 1HG001 breaker Aux Bldg MCC 1A3. _____
 - d) Deenergize/Verify Deenergized the 1HG004 breaker at Aux Bldg MCC 1A3. _____
 - e) Place the handswitch for 1HG001/1HG004 in the Closed position. _____
 - f) Verify Shut 1HG001 Unit 1 CGCS Cmnt Isol. **(J)** _____
 - g) Verify Open 1HG004 Unit 1 CGCS Cmnt Isol. _____

INITIAL

- 8.2.1.3 Shut/Check Shut 1HG016, Cnmt Suction Hdr Test Conn
(Aux Bldg 755' RT Pmp Room Mezz). **(RC, J)** _____
- 8.2.1.4 Open/Check Open the following: (Cont Bldg 702')
 - a) 1HG002, H2 Recombiner Suct Isol _____
 - b) 1HG003, H2 Recombiner Return Isol _____
- 8.2.1.5 Open/Check Open the following:
(Aux Bldg 755', RT Pmp Rm Mezz)
 - a) 1HG012, Cnmt Suction Hdr Isol _____
 - b) 1HG013, Cnmt Return Isol _____
- 8.2.1.6 Remove/Verify removed the blank flange on line
1HG02B; ensure line is vented. (Cnmt 750') **(TV)** _____
- 8.2.1.7 Perform LLRT per CPS 2761.02, LOCAL LEAK
RATE TESTING EQUIPMENT. _____

Test Set A (1HG001, 1HG016)					
Test Medium - Dry Air			Test Type - Flow Rate		
Start Time of Test:			Date		Time
Elapsed Time*		Pressure**		Flow	
0	min		psig		sccm
5	min		psig		sccm
10	min		psig		sccm
15	min		psig		sccm
	min		psig		sccm
	min		psig		sccm
* Elapsed time for test to be 15 min. minimum from stabilization.					
** Pressure to be 9.1 psig minimum to 9.9 psig maximum.					
Established Flow Start			sccm	±	sccm
Established Flow End			sccm	±	sccm
Maximum Flow Rate			Sscm	±	sccm

$$\begin{array}{ccccccc}
 \text{_____} & - & \text{_____} & = & \text{_____} & + & \text{_____} & \text{sccm} \\
 \text{Max Flow} & & \text{Established} & & \text{Indicated} & & \text{Tolerance} & \\
 & & \text{Flow} & & \text{Leakage} & & &
 \end{array}$$

INITIAL

- 8.2.2 TEST SET B (1HG017, 1HG004)
- 8.2.2.1 Connect leak rate test equipment at the end of line 1HG02B. **(TC)** _____
- 8.2.2.2 Shut 1HG004 and Open 1HG001 by performing the following in order at 1H13-P800 & AB MCC 1A3:
- a) Notify the MCR about repositioning breakers. _____
 - b) Place the handswitch for 1HG001/1HG004 in the Open position. _____
 - c) Energize/Verify Energized the 1HG004 breaker at Aux Bldg MCC 1A3. _____
 - d) Deenergize/Verify Deenergized the 1HG001 breaker at Aux Bldg MCC 1A3. _____
 - e) Place the handswitch for 1HG001/1HG004 in the Closed position. _____
 - f) Verify Shut 1HG004 Unit 1 CGCS Cmnt Isol. **(J)** _____
 - g) Verify Open 1HG001 Unit 1 CGCS Cmnt Isol. _____
- 8.2.2.3 Shut/Check Shut 1HG017, Cmnt Return Hdr Test Conn (Aux Bldg 755' RT Pmp Room Mezz). **(RC, J)** _____
- 8.2.2.4 Open/Check Open the following: (Cont Bldg 702')
- a) 1HG002, H2 Recombiner Suct Isol _____
 - b) 1HG003, H2 Recombiner Return Isol _____
- 8.2.2.5 Open/Check Open the following:
(Aux Bldg 755', RT Pmp Rm Mezz)
- a) 1HG012, Cmnt Suction Hdr Isol _____
 - b) 1HG013, Cmnt Return Isol _____
- 8.2.2.6 Remove/Verify Removed the blank flange on line 1HG01A; ensure line is vented (Cmnt 750').

8.2.2.7 Perform LLRT per CPS 2761.02, Local Leak Rate Testing Equipment.

Test Set B (1HG004 And 1HG017)					
Test Medium - Dry Air			Test Type - Flow Rate		
Start Time of Test:			Date		Time
Elapsed Time*		Pressure**		Flow	
0	min		psig		sccm
5	min		psig		sccm
10	min		psig		sccm
15	min		psig		sccm
	min		psig		sccm
	min		psig		sccm
* Elapsed time for test to be 15 min. minimum from stabilization.					
** Pressure to be 9.1 psig minimum to 9.9 psig maximum .					
Established Flow Start			sccm	±	sccm
Established Flow End			sccm	±	sccm
Maximum Flow Rate			Sscm	±	sccm

$$\begin{array}{ccccccc}
 \underline{\hspace{2cm}} & - & \underline{\hspace{2cm}} & = & \underline{\hspace{2cm}} & + & \underline{\hspace{2cm}} \text{ sccm} \\
 \text{Max Flow} & & \text{Established} & & \text{Indicated} & & \text{Tolerance} \\
 & & \text{Flow} & & \text{Leakage} & &
 \end{array}$$

INITIAL

8.2.3.6 Shut/Check Shut the following: (Aux Bldg 707',
(LPCS Pmp Room)

a) 1HG020, Cnmt Suction Hdr Drain _____

b) 1HG021, Cnmt Return Drain _____

8.2.3.7 Open/Check Open the following:
(Aux Bldg 755', (RT Pmp Rm Mezz))

a) 1HG012, Cnmt Suction Hdr Isol _____

b) 1HG013, Cnmt Return Isol _____

8.2.3.8 Perform LLRT per CPS 2761.02, Local Leak
Rate Testing Equipment. _____

Test Set C (Closed Loop)					
Test Medium - Dry Air			Test Type - Flow Rate		
Start Time of Test:			Date		Time
Elapsed Time*		Pressure**		Flow	
0	min		psig		sccm
5	min		psig		sccm
10	min		psig		sccm
15	min		psig		sccm
	min		psig		sccm
	min		psig		sccm
* Elapsed time for test to be 15 min. minimum from stabilization.					
** Pressure to be 9.1 psig minimum to 9.9 psig maximum .					
Established Flow Start			sccm	\pm	sccm
Established Flow End			sccm	\pm	sccm
Maximum Flow Rate			Sscm	\pm	sccm

$$\begin{array}{ccccccc}
 \underline{\hspace{2cm}} & - & \underline{\hspace{2cm}} & = & \underline{\hspace{2cm}} & + & \underline{\hspace{2cm}} & \text{sccm} \\
 \text{Max Flow} & & \text{Established} & & \text{Indicated} & & \text{Tolerance} & \\
 & & \text{Flow} & & \text{Leakage} & & &
 \end{array}$$

8.2.4 Supplemental Test Lineups, if needed, to be added IAW step 8.2.4 of CPS 9861.02. Additional pages may be added if required.

8.2.4.1 Obtain the SM/CRS concurrence IAW 8.2.4 of CPS 9861.02.

8.2.4.2 Obtain the LLRT Coordinator concurrence IAW 8.2.4 of CPS 9861.02.

_____	_____	_____
_____	_____	_____
_____	_____	_____
_____	_____	_____
_____	_____	_____
_____	_____	_____
_____	_____	_____

8.3 **RESTORATION**

8.3.1 SM/CRS notified of test completion.

Date / Time

8.3.2 OHG01SA is restored.

8.3.3 Test plug/flange removal:

8.3.3.1 Remove the test plug/flange from lines 1HG01A and 1HG02B.

CV _____ / _____

8.3.3.2 Notify the RO/CRS of test plug/flange removal.

8.3.4 Breakers for 1HG001 and 1HG004 have been restored.

Date / Time

INITIAL

8.3.5 Verify testing equipment removed. _____

8.3.6 The system is fully restored from testing using _____
the following valve/electrical lineups:

OR

The system is partially restored due to _____
plant/outage conditions and as directed
by the SM/CRS (List partial system status,
ie.: partial lineups performed, tagouts in
effect, MCR Log entries as appropriate)

8.3.7 SM/CRS notified of test completion. _____

/_____
Date / Time

9.0 **ACCEPTANCE CRITERIA**

9.1 **Operability Requirements**

9.1.1 This penetration does not have individual leakage limits. The leakage for any containment penetration should not contribute excessively to the overall Type B and Type C leak rate (ITS 3.6.1.1.1) and the Secondary Containment Bypass Leakage Rate (SR 3.6.1.3.8). Leakage is monitored by the Administrative Limit in 9.2.1 and by the NSED App J LLRT Engineer review.

9.2 **Other Requirements**

9.2.1 Administrative Limit: **1,000** sccm. _____

9.2.1.1 If this limit is exceeded, immediately contact the ISI Pressure Test Program Engineer/Designee to ensure the commitments of Relief Request I3R-09 are met.

9.2.1.2 If this limit is exceeded, initiate an IR and contact the NSED App J LLRT Engineer for evaluation of overall Containment leakage (ITS 3.6.1.1.1) and Secondary Containment Bypass Leakage (SR 3.6.1.3.8).

STEP	COMPONENT	ACTUAL LEAKAGE	INITIAL
8.2.1.7	TEST SET A, (1HG001, 1HG016)	± sccm	
8.2.2.7	TEST SET B, (1HG004, 1HG017)	± sccm	
8.2.3.8	TEST SET C, (Closed Loop)	± sccm	

NSED App J LLRT Engineer Actions:

1. Retrieve/obtain previous test results for Comparison to the test results obtained during this test. _____
2. Compare test results to previous test results. Evaluate trends and initiate further action if required. _____

9.0 ACCEPTANCE CRITERIA9.2 Other Requirements (cont'd)

9.2.1.2 (continued)

ISI Pressure Test Program Engineer Actions:

1. Evaluate the test results to determine if the leakage is due to through-wall leakage in the pressure boundary. _____
2. Ensure troubleshooting is performed to locate the source of any excess leakage (as needed). _____
3. Ensure any leakage identified is corrected and the test set is run again. If troubleshooting determines that leakage above the administrative limit may be attributed to a through-wall pressure boundary leak, VT-2 qualified personnel shall perform an examination of the affected area with a leak detection solution. If through-wall pressure boundary leakage is discovered, immediately inform the Shift Management and ensure the component or piping is repaired or replaced in accordance with the applicable ASME Code requirements. _____
4. If evidence of safety-related pressure boundary leakage is not located, the examination will be considered acceptable for ISI Pressure Testing Program requirements for the ISI Period. _____

9.2.2 Once the total leakage per Test Set is less than or equal to **1000** sccm for Test Sets A,B,and C, the leakage may be considered acceptable and this surveillance may be restored in a routine manner. _____

SUPPLEMENTAL REVIEW SHEET

CORRECTIVE ACTION TAKEN

9.1 OPERABILITY Requirements

ITS LCOs: 3.6.1.1 3.6.1.3 3.6.4 SR 3.6.1.3.8

ORM ORs: 2.4.10 2.5.2

As applicable:

Issue Report Initiated _____

(yes/no)

Issue Report # _____

9.2 OTHER Requirements

As applicable:

Issue Report Initiated _____

(yes/no)

Issue Report # _____

NOTES\COMMENTS

REVIEW AND APPROVAL

NSED LLRT Coordinator: _____ (Signature) _____ (Date)

Pressure Test Program Manager: _____ (Signature) _____ (Date)

IST Program Coordinator: _____ (Signature) _____ (Date)

Shift Management: _____ (Signature) _____ (Date)

1MC-71/72 TEST SET A LINEUP

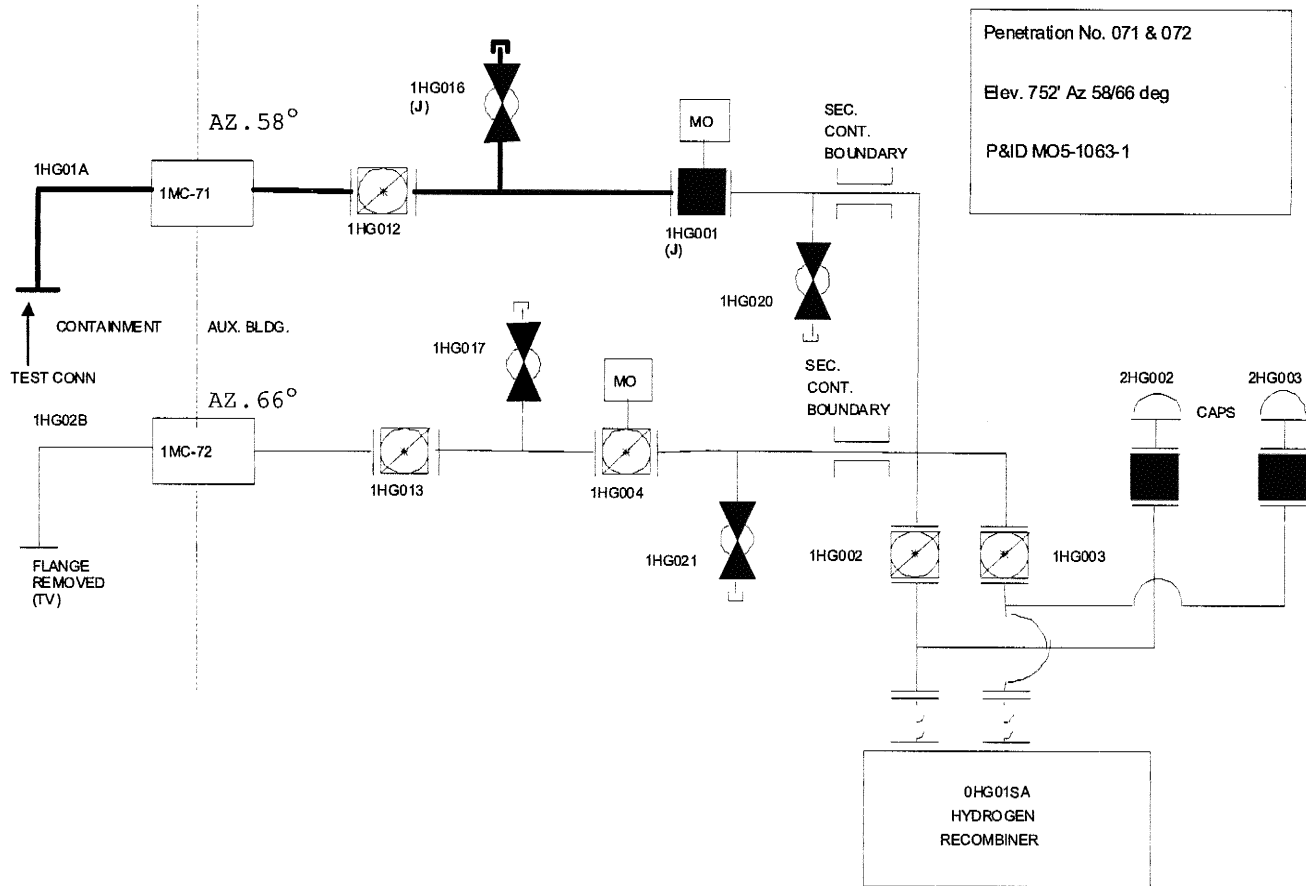

Filled in valves = shut Test Volume in Bold
 Test Valves: (1HG016 & 1HG001)

Procedure Step	EIN	Position
8.2.1.1	1HG01A Line	Test Conn
8.2.1.2f	1HG001	Shut (J)
8.2.1.2g	1HG004	Open
8.2.1.3	1HG016	Shut (RC, J)
8.2.1.4a	1HG002	Open
8.2.1.4b	1HG003	Open
8.2.1.5a	1HG012	Open
8.2.1.5b	1HG013	Open
8.2.1.6	Line 1HG02B	Vented

1MC-71/72 TEST SET B LINEUP

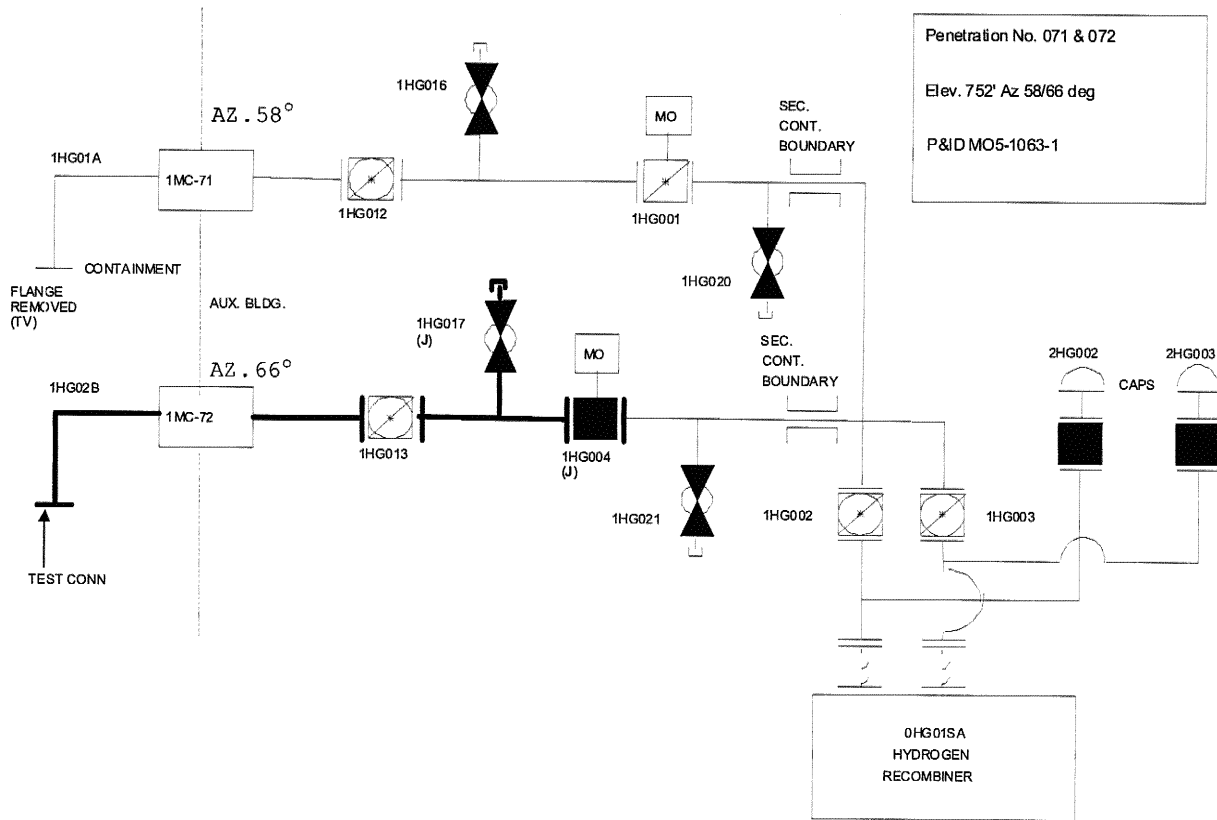

Filled in valves = shut Test Volume in Bold
 Test Valves: (1HG017 & 1HG004)

Procedure Step	EIN	Position
8.2.2.1	1HG02B Line	Test Conn
8.2.2.2f	1HG004	Shut (J)
8.2.2.2g	1HG001	Open
8.2.2.3	1HG017	Shut (RC, J)
8.2.2.4a	1HG002	Open
8.2.2.4b	1HG003	Open
8.2.2.5a	1HG012	Open
8.2.2.5b	1HG013	Open
8.2.2.6	Line 1HG01A	Vented

1MC-71/72 TEST SET C LINEUP

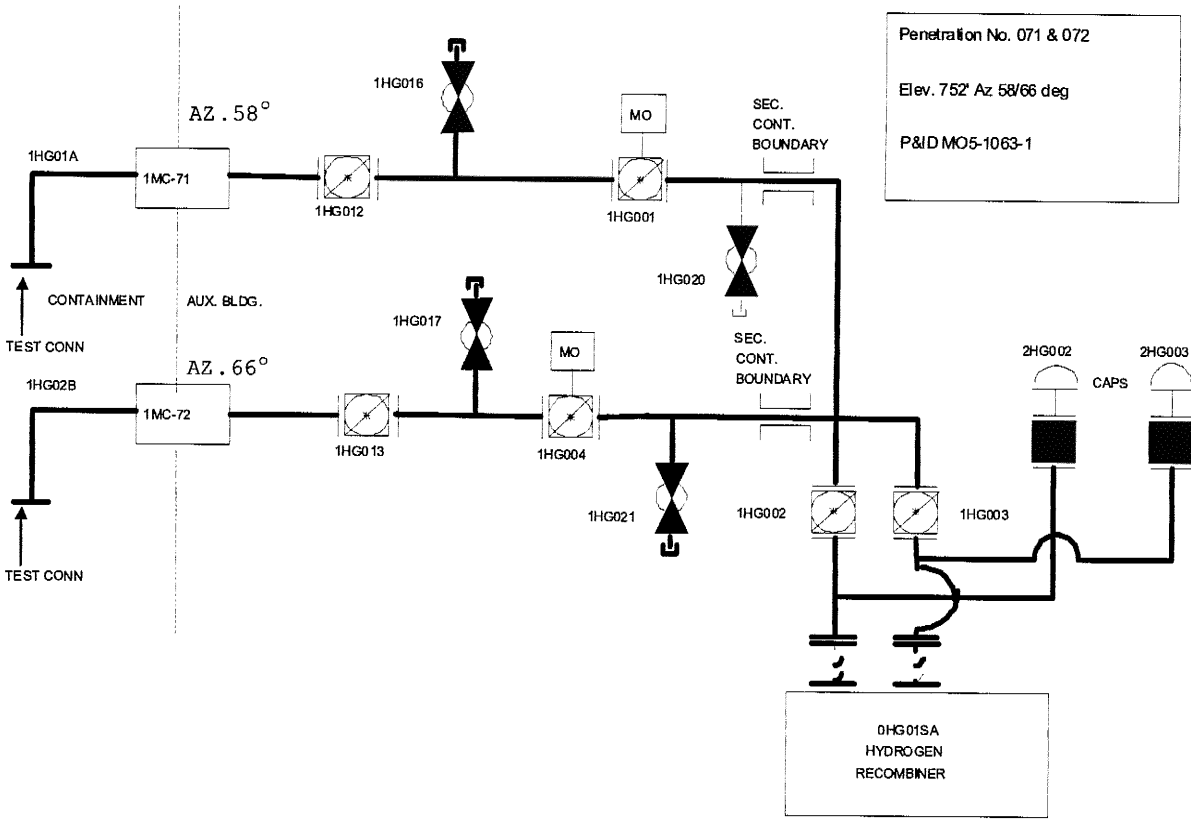

Filled in valves = shut Test Volume in Bold
 Test: (Closed Loop)

Procedure Step	EIN	Position
8.2.3.1	1HG01A Line	Test Conn
8.2.3.1	1HG02B Line	Test Conn
8.2.3.2e	1HG004	Open
8.2.3.2f	1HG001	Open
8.2.3.3a	1HG016	Shut
8.2.3.3b	1HG017	Shut
8.2.3.4a	2HG002	Shut
8.2.3.4b	2HG003	Shut
8.2.3.5a	1HG002	Open
8.2.3.5b	1HG003	Open
8.2.3.6a	1HG020	Shut
8.2.3.6b	1HG021	Shut
8.2.3.7a	1HG012	Open
8.2.3.7b	1HG013	Open