

# UNIVERSITY *of* MISSOURI

RESEARCH REACTOR CENTER

September 18, 2012

U.S. Nuclear Regulatory Commission  
ATTN: Document Control Desk  
Mail Stop P1-37  
Washington, D.C. 20555-0001

Reference: Docket Number 50-186  
University of Missouri-Columbia Research Reactor  
License R-103

Subject: Written communication as required by the University of Missouri  
Research Reactor Technical Specification 6.1.h(2) regarding a deviation  
from Technical Specification 3.10.b

The attached document provides the University of Missouri-Columbia Research Reactor (MURR) Licensee Event Report (LER) for an event that occurred on August 23, 2012 that resulted in a deviation from MURR Technical Specification 3.10.b.

If you have any questions regarding this report, please contact John L. Fruits, the facility Reactor Manager, at (573) 882-5319.

Sincerely,



Ralph A. Butler, P.E.  
Director

RAB/djr

Enclosure

xc: Reactor Advisory Committee  
Reactor Safety Subcommittee  
Dr. Robert V. Duncan, Vice Provost of Research  
Mr. Alexander Adams, Jr., U.S. NRC  
Mr. Craig Bassett, U.S. NRC

IE22  
A020  
MURR



**Licensee Event Report No. 12-02 – August 23, 2012**  
**University of Missouri Research Reactor**

**Introduction**

On August 23, 2012, with the reactor operating at 10 MW in the automatic control mode, the control room operator discovered that the control switches for pressurizer Water Drain Valve 527A were in the manual and closed positions. The automatic/manual switch for valve 527A was immediately placed in the automatic position. This valve switch is required to be in the automatic position whenever the reactor is in operation. At the time, pressurizer liquid level was approximately 3.0 inches below centerline (-3.0 inches); which is within the controlled normal operating band of +2.0 to -6.0 inches. With Water Drain Valve 527A switch in the manual position, a valve interlock would have prevented pressurizer Water Addition Valve 527B from opening and Primary Coolant Charging Pump P-533 from starting had pressurizer liquid level decreased to a set point of -6.0 inches.

Primary Coolant Charging Pump P-533 delivers make-up water to the Primary Coolant System via the pressurizer from make-up water storage tank T-300. In accordance with Technical Specification (TS) 3.10.b, *“the reactor shall not be operated unless the reactor makeup water system is operable and connected to a source of at least 2,000 gallons of primary grade water.”* The basis for this Specification is to provide *“...an adequate supply of primary grade water for makeup during all modes of operation.”* With the potential of Primary Coolant Charging Pump P-533 not starting as required by system demand, the Reactor Make-Up Water System was in a degraded state and not considered operable.

**Description of the Reactor Make-Up Water System**

The Reactor Make-Up Water System is not specifically defined or described in the TSs or the Hazards Summary Report (HSR). TS 3.10.b and its basis imply that the system consists of a pressurizer tank; a positive displacement pump (Primary Coolant Charging Pump P-533); automatic control valves; a primary grade water supply; and associated piping, valves, and instrumentation. These components are shown on MURR Drawing No. 2325, “Pressurizer/Nitrogen System,” which is attached as Page 6 to this document. The Primary Coolant Charging Pump is labeled as Level Control Pump P533 on this drawing. The purpose of the nitrogen supply system is to automatically supply nitrogen gas to the pressurizer to ensure that pressure in the Primary Coolant System is maintained within the Limiting Safety System Settings (LSSSs) for 10 MW operation.

Pressurizer liquid level is controlled within a normal operating band of +2.0 to -6.0 inches. This is accomplished by the addition of primary grade water with Primary Coolant Charging Pump P-533 if the level is low, and draining water to the drain

collection system through Water Drain Valve 527A if the level is high. If liquid level decreases to approximately -6.0 inches, level controller LC936 initiates a signal to automatically open Water Addition Valve 527B and start Primary Coolant Charging Pump P-533. This occurs when valve 527B "open" position limit switch LS1-1 energizes relay 2K15, which then closes contact 3-4 in the control circuitry of Coolant Charging Pump P-533, causing the pump to automatically start. This circuit wiring diagram is attached as Page 5 to this document. Valve 527B is an air-operated-to-open, spring-to-close (fail-safe) diaphragm valve. This valve/pump interlock arrangement prevents the positive displacement charging pump from operating without an open discharge path.

The pump will continue to operate until liquid level is approximately +1.0 inches. At this time the pump will stop and valve 527B will close. At a design flow rate capacity of 50 gpm, the coolant charging pump will run for approximately 1 minute. If pressurizer liquid level continues to decrease to -11.0 inches, level controller LC935 will initiate a "Pressurizer Water Lo Level" annunciator alarm alerting the operators to the abnormal condition. Should pressurizer liquid level lower to -13.0 inches, level controller LC935 will initiate a reactor scram by opening contact K28-2 in the process input string to E3B of the Reactor Safety System Non-Coincidence Logic Units, thereby interrupting power to the control blade electromagnets. In addition, a "Pressurizer Lo Level Scram" annunciator alarm is initiated and Surge Line Isolation Valve 527C closes to prevent an introduction of nitrogen gas into the Primary Coolant System.

Water Addition Valve 527B is interlocked with Water Drain Valve 527A such that valve 527B will not open automatically unless the switches for valve 527A are in the automatic/closed positions. This valve interlock prevents the addition of water to the pressurizer unless an automatic drain path exists.

### **Detailed Event Description**

On August 23, 2012, with the reactor operating at 10 MW in the automatic control mode, the control room operator discovered that the control switches for pressurizer Water Drain Valve 527A were in the manual and closed positions. The automatic/manual switch for valve 527A was immediately placed in the automatic position. This valve is required to be in the automatic position whenever the reactor is in operation. At the time, pressurizer liquid level was approximately -3.0 inches; which is within the controlled normal operating band of +2.0 to -6.0 inches.

### ***Background***

On Tuesday, August 21, 2012 the reactor was shut down at 22:27 as a result of an electrical anomaly. After maintenance and refueling had been completed, and prior to reactor operation, the Primary Coolant System was placed on-line at approximately 01:45 on Wednesday, August 22, 2012. During the process of placing the Primary Coolant System on-line, the control switch for valve 527A was not placed in the automatic

position as required by Step 5.3.3 of operating procedure OP-RO-410, "Primary Coolant System." A reactor startup was commenced at 02:04. The incorrect valve switch condition remained undetected until 16:42 on August 23, 2012 at which time the control room operator immediately placed the valve 527A switch in the automatic position. Therefore, the reactor operated for a total of 38 hours and 38 minutes in violation of TS 3.10.b.

### **Safety Analysis**

The potential of Water Addition Valve 527B to not automatically start Primary Coolant Charging Pump P-533, if system demand had required it to, did not present a safety hazard to the reactor or any reactor coolant system. The Reactor Make-Up Water System is not part of the reactor safety system nor is it a facility design feature that is assumed to be operational in any accident analysis analyzed in the HSR or required by any reactor emergency procedure. The system provides a means for the addition of primary grade water that is lost during normal operation of the reactor through coolant sampling, pump seal leakage, etc. The system is not designed to provide make-up water for the protection against any significant leaks in the Primary Coolant System.

Furthermore, should a significant Primary Coolant System leak develop, a reactor scram would be initiated by low system pressure. Pressure transmitters PT-944A and PT-944B would also cause Primary Coolant Circulation Pumps P-501A and P-501B to stop and Primary Coolant Isolation Valves 507A and 507B to close. Closure of these valves would isolate the pressurizer and Reactor Water Make-Up System from the reactor pressure vessel and core.

### **Corrective Actions**

When it was discovered that a reactor auxiliary system Limiting Condition for Operation was not satisfied with respect to the Reactor Make-Up Water System (TS 3.10.b), the valve position switch for pressurizer Water Drain Valve 527A was immediately placed in the automatic position. This satisfied the operational interlock associated with pressurizer Water Addition Valve 527B and allowed Primary Coolant Charging Pump P-533 to function automatically, if required by system demand.

As an additional verification for all Primary Coolant System valve position switches, Step 5.4.25 of operating procedure OP-RO-410, "Primary Coolant System," was revised to include a list of each Primary Coolant System valve switch position and its corresponding valve position indicating light illumination. Each item is verified after the Primary Coolant System is placed on-line. Previously, the step only stated "ENSURE all applicable valve position indication lights are lit."

To increase the awareness of Reactor Operations personnel, Step 6.5.2.c of administrative procedure AP-RO-110, "Conduct of Operations," was also revised to include more specific instructions as to what items shall be reviewed by personnel from the oncoming shift prior to assuming operational duties.

The need for additional attention to detail was discussed with Reactor Operations personnel. All Reactor Operators will attend a future training session on how to improve human performance and use of the STAR principle (Stop, Think, Act, Review). Additionally, this event has been entered into the MURR Corrective Action Program as CAP entry No. 12-0032 and any additional improvements or corrective actions will be considered.

If there are any questions regarding this LER, please contact me at (573) 882-5319. I declare under penalty of perjury that the foregoing is true and correct.

Sincerely,

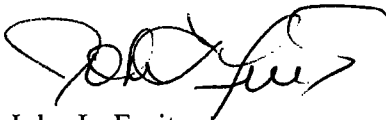

John L. Fruits  
Reactor Manager

ENDORSEMENT:  
Reviewed and Approved,



Ralph A. Butler, P.E.  
Director

*Christine M. Errante 9/18/12*

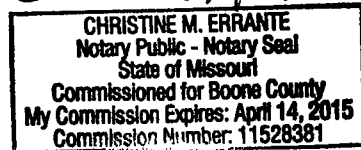

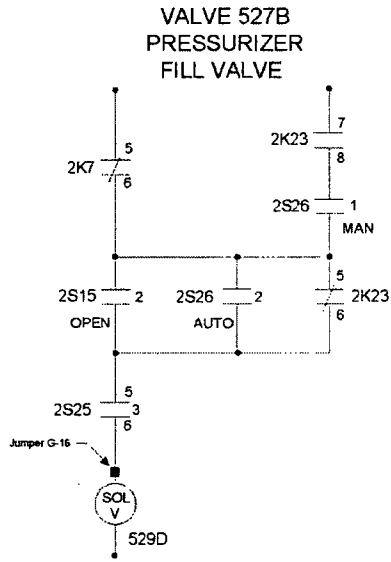

**VALVE FAILS CLOSED**

- 2S15 OPEN/CLOSED
  - 2S26 AUTO/MANUAL
  - 2S25 V527A AUTO/MANUAL
- 
- 2K7(5/6) Opens on high level (LC936)
  - 2K23(7/8) Closed when 1S1 in TEST
  - 2K23(9/10) Open when 1S1 in TEST
  - 2S26(1) Closed when in MANUAL
  - 2S26(2) Closed when in AUTO
  - 2S15(2) Closed when in OPEN
  - 2S25(3) Closed when V527A in AUTO

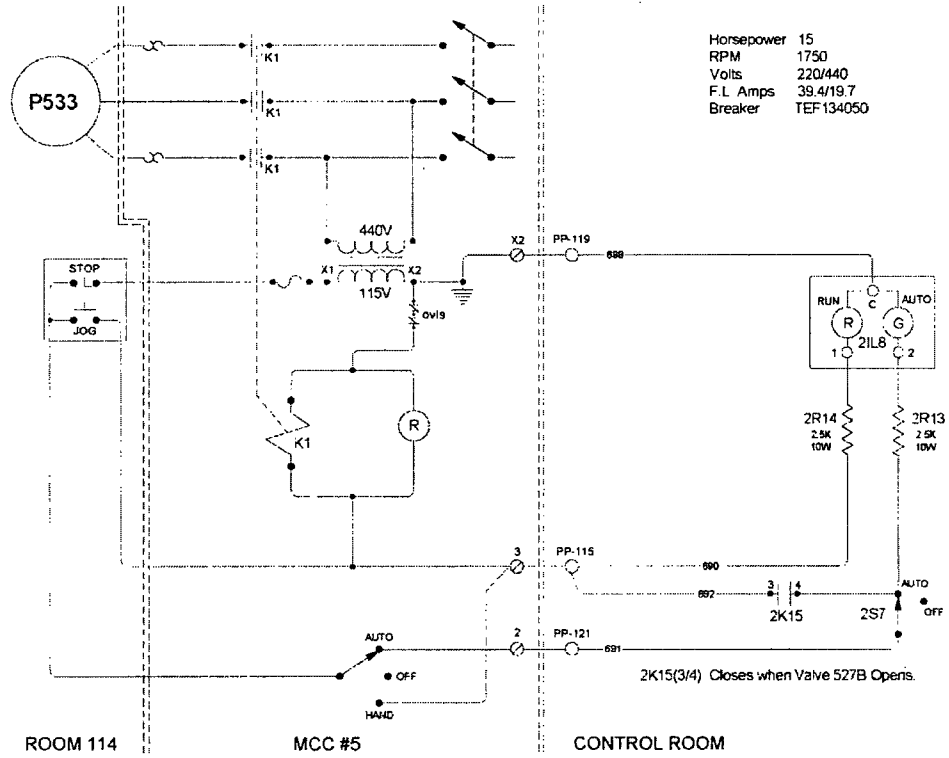

Horsepower 15  
 RPM 1750  
 Volts 220/440  
 F.L. Amps 39.4/19.7  
 Breaker TEF134050

2K15(3/4) Closes when Valve 527B Opens.

