



GE Nuclear Energy

GERIS 2000 Examination Summary Sheet

335

Project: TVA, Browns Ferry Nuclear Plant, Unit 3
System: Reactor Pressure Vessel
Weld ID: V-2-A **ASME Code Category:** B-A

Calibration Sheets: C-003

Supporting Data: Examination Data Sheets E-05-00 thru E-05-05, Indication Data Sheets 05-001 thru 05-008 and G-001 thru G-008, Screen Prints, Exam Patch Location Map, Exam Coverage Plots and GERIS 2000 Setup Records.

Examination Summary

The ultrasonic examination of weld V-2-A resulted in no recorded indications that exceed the allowable standards of IWB-3500, ASME Section XI, 1986 Edition, No Addenda.

The ASME Section XI required examination volume was examined with the GERIS 2000 System from the RPV inside surface utilizing Procedure No. GE-UT-700, Rev. 2. This examination was limited due to the N16-A Nozzle at 40° and the Jet Pump brackets at 30° and 60°. The total examination coverage was calculated to be 85%.

The GERIS 2000 utilizes an array of search units arranged to effectively examine the weld and adjacent base material parallel and perpendicular to the weld axis in two directions. The transducer package consisted of 0° longitudinal, 45° and 60° shear wave, and 70° refracted longitudinal (RL) wave search units.

The GERIS 2000 recorded indications with the 0° weld metal scan, 70°RL, 45° and 60° shear wave scans that were evaluated and found to be acceptable per the referencing Code section. Geometric indications from the N16-A Nozzle and OD surface were recorded with the 45° and 60° shear wave scans.

No manual supplemental examination was performed from the RPV outside surface due to access restrictions.

Fabrication records and previous examination results were reviewed prior to the completion of this examination summary.

GERIS Analyst: <i>CO Ma</i>	GE Reviewer: <i>Alesia Kimball</i>
LEVEL: <i>III</i> DATE: <i>12/15/93</i>	LEVEL: <i>III</i> DATE: <i>12-15-93</i>
UTILITY Review: <i>J. Woody</i>	ANII Review:
TITLE: <i>II</i> DATE: <i>1/26/94</i>	TITLE: <i>About Weld</i> DATE: <i>9/8/94</i>

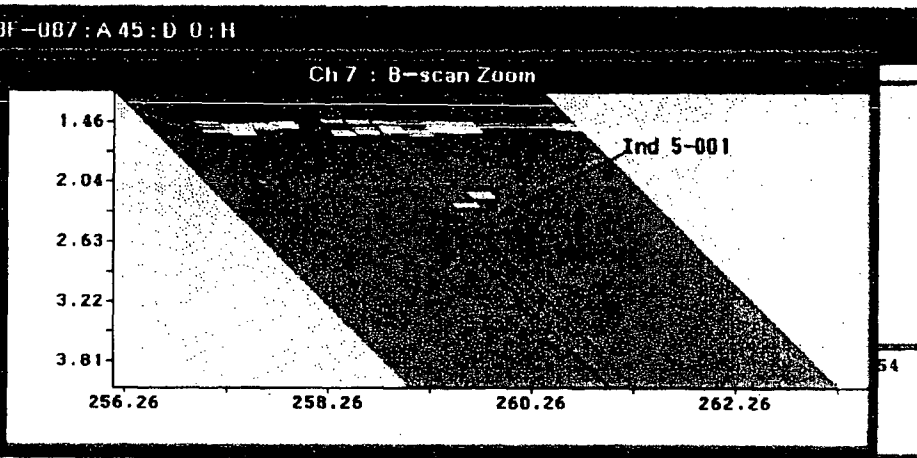
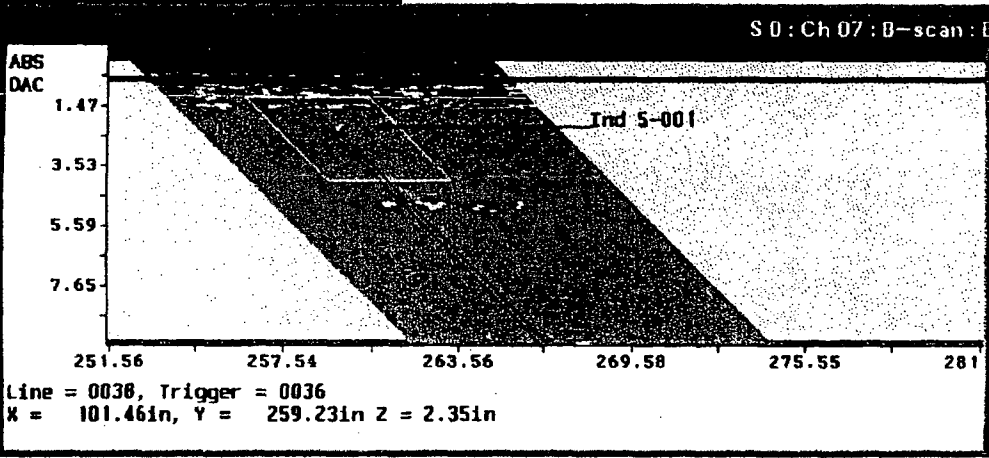
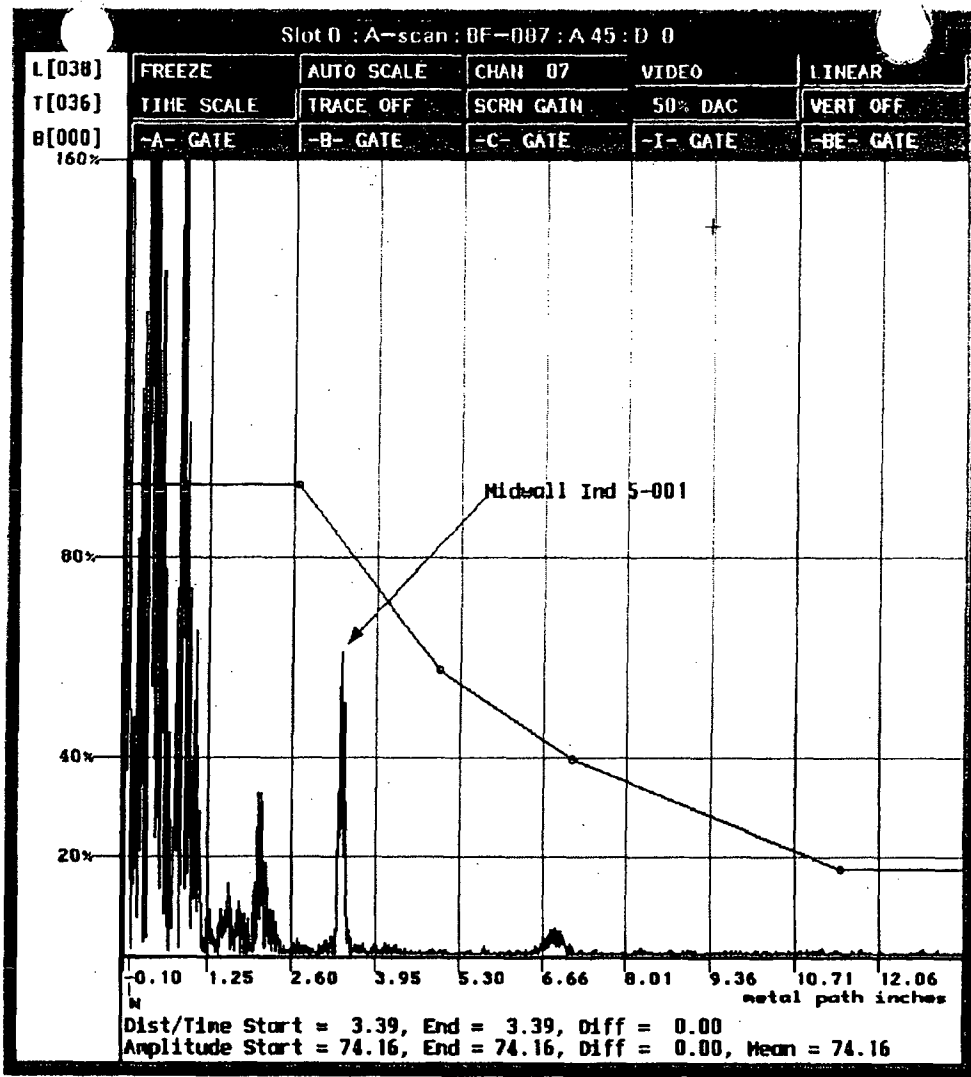
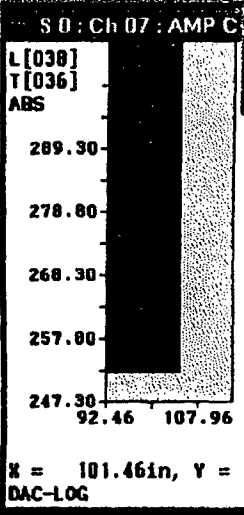
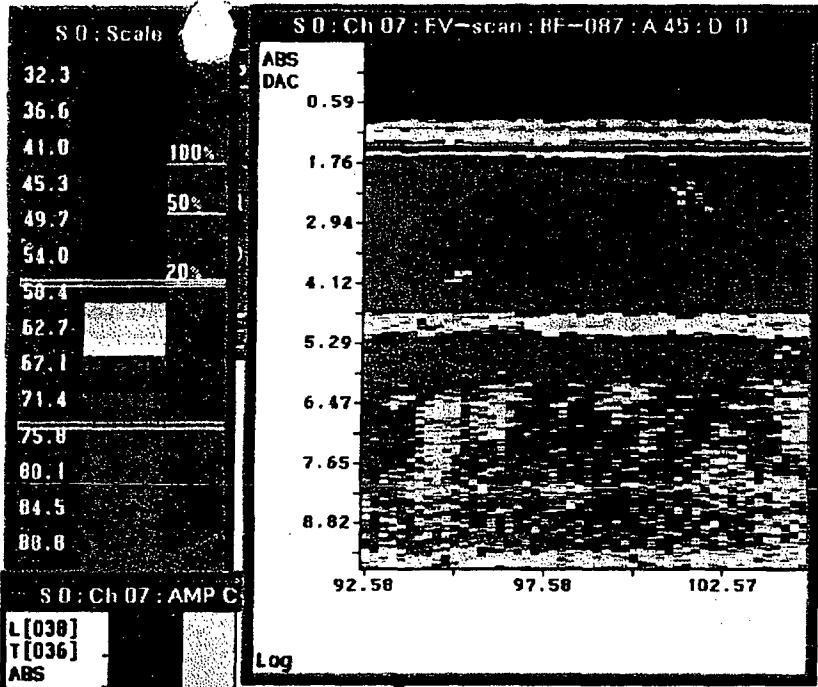

2410543 • 00024

R111005

S 0 : Scale

32.3
36.6
41.0
45.3
49.7
51.0
58.4
62.7
67.1
71.4
75.8
80.1
81.5
88.0
93.2

100%
50%
20%

DAC

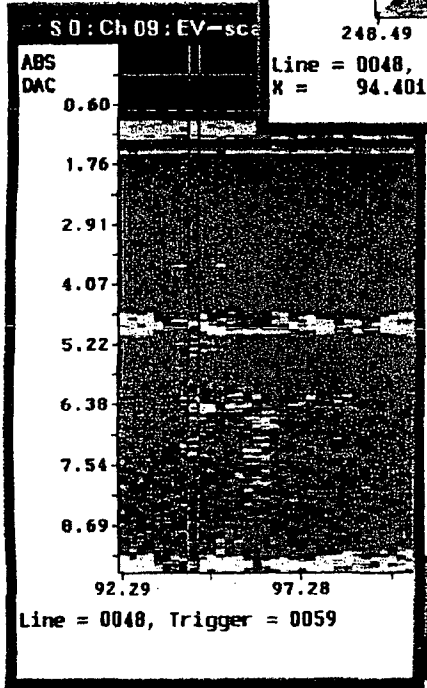
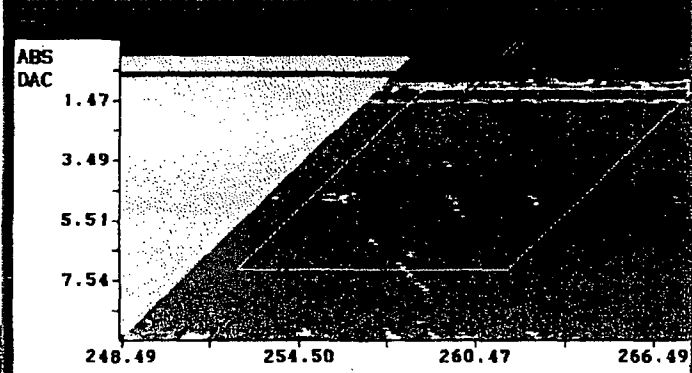
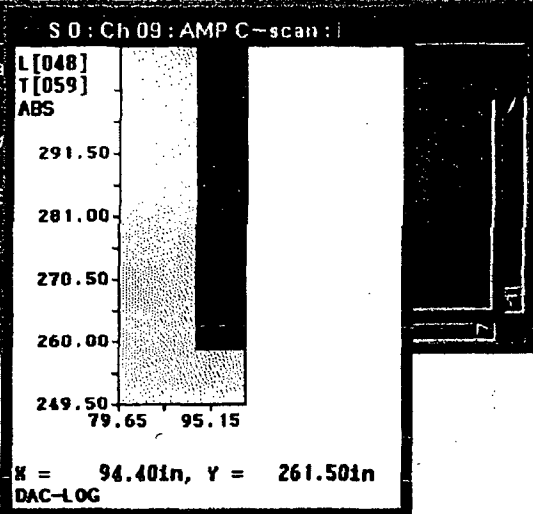

hpterm
extor 3/5-002

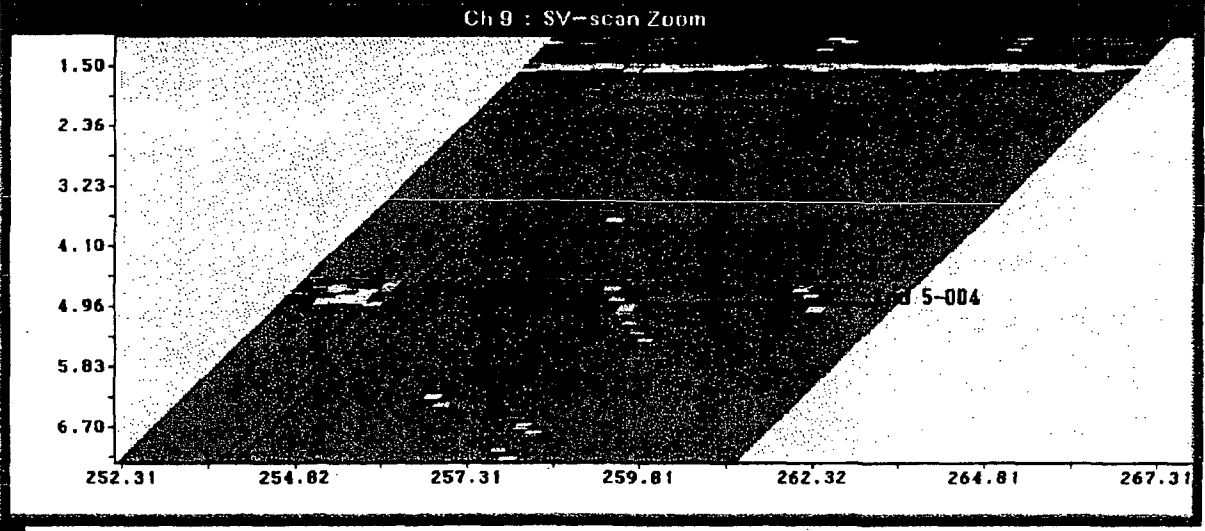
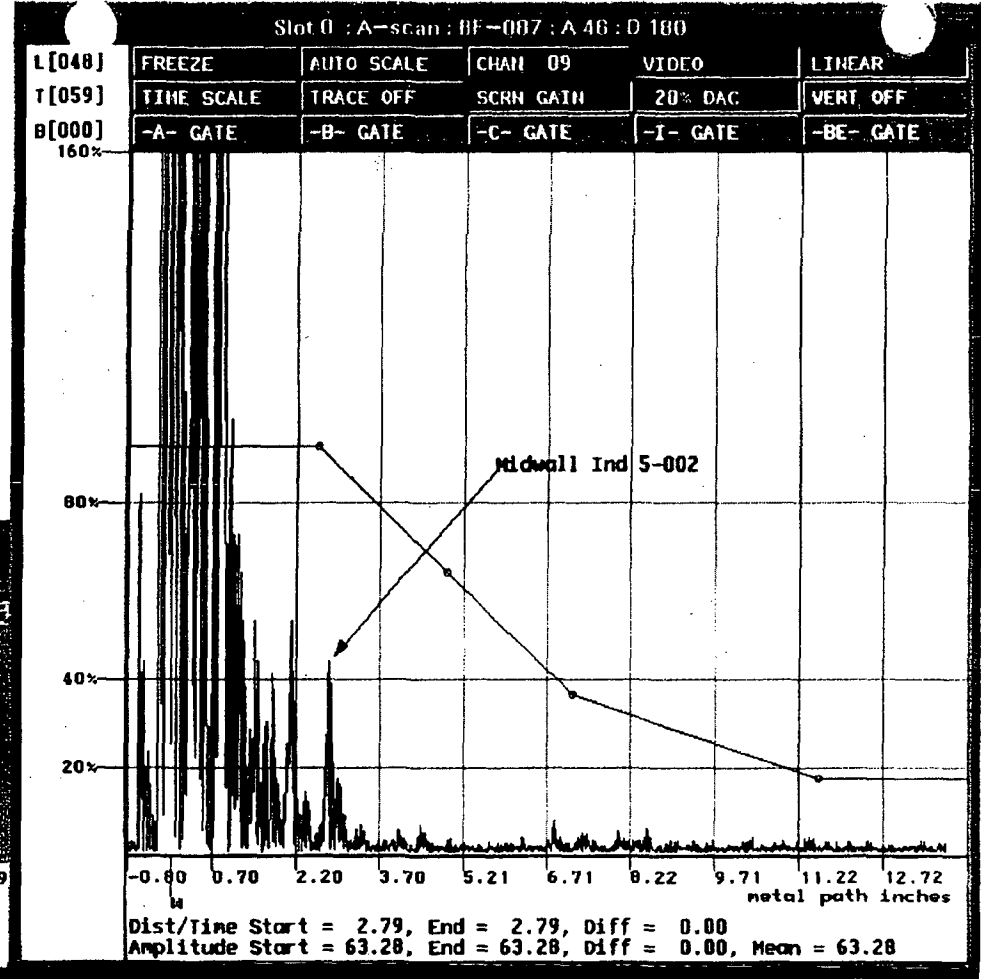

Page 0
25 of 43
00025

S 0 : Scale

32.3
36.6
41.0
45.3
49.7
51.0
56.4
62.7
67.1
71.4
75.0
80.1
81.5
88.8
93.2

100%
50%
20%

DAC

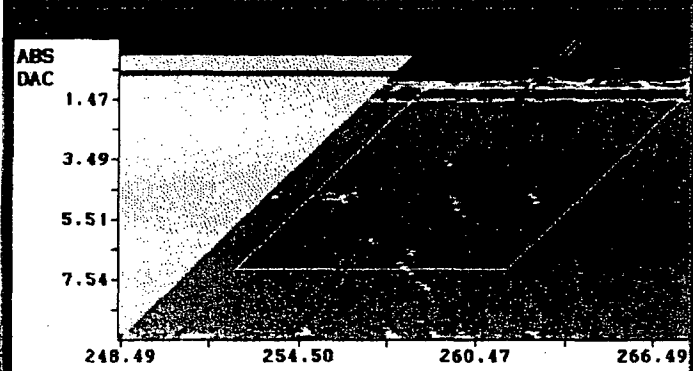
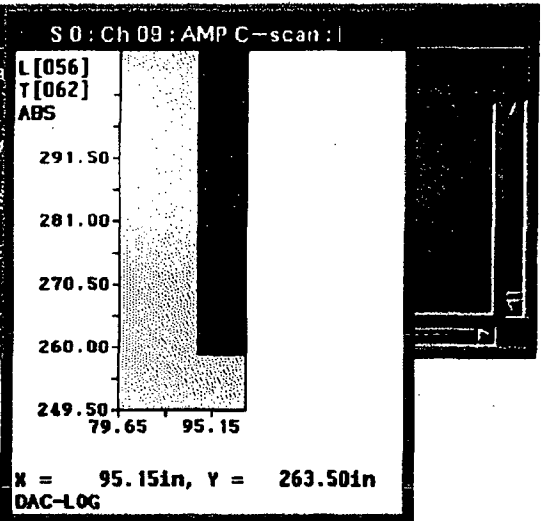

Line = 0056, Trigger = 0062
X = 95.15in, Y = 259.44in Z = 3.68in

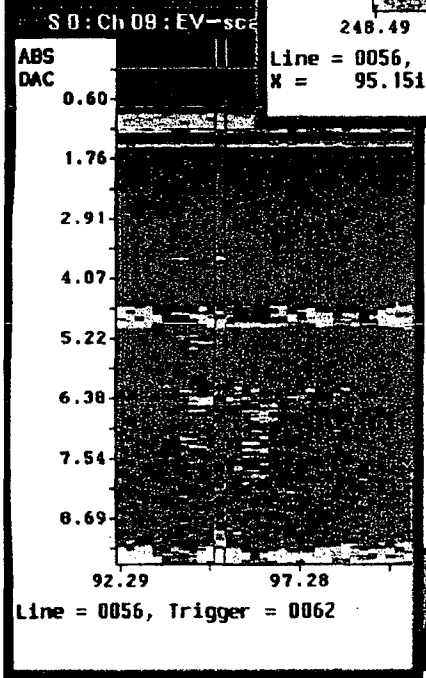

hpterm
axtor3/5-003

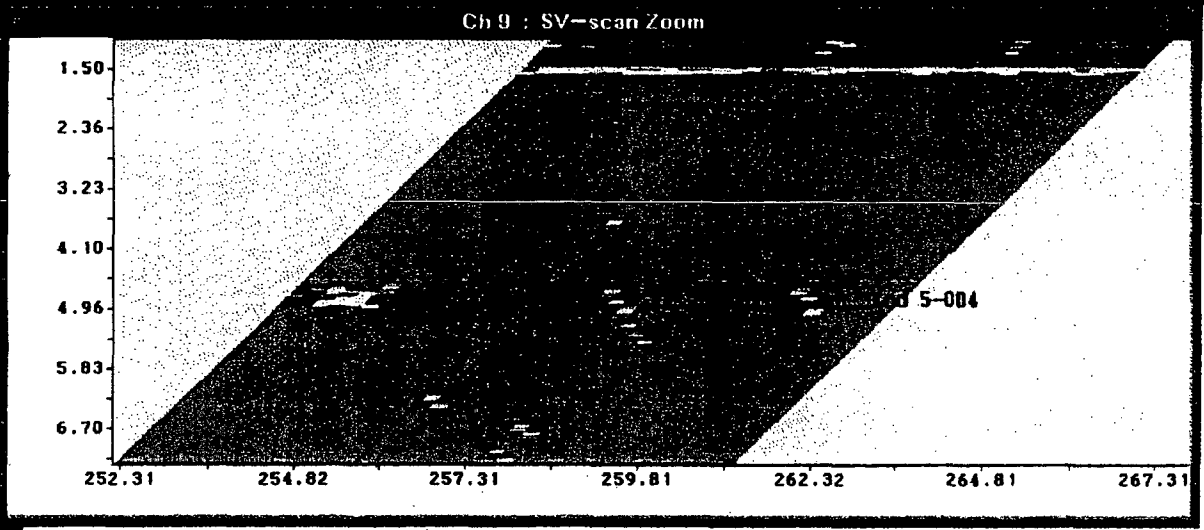
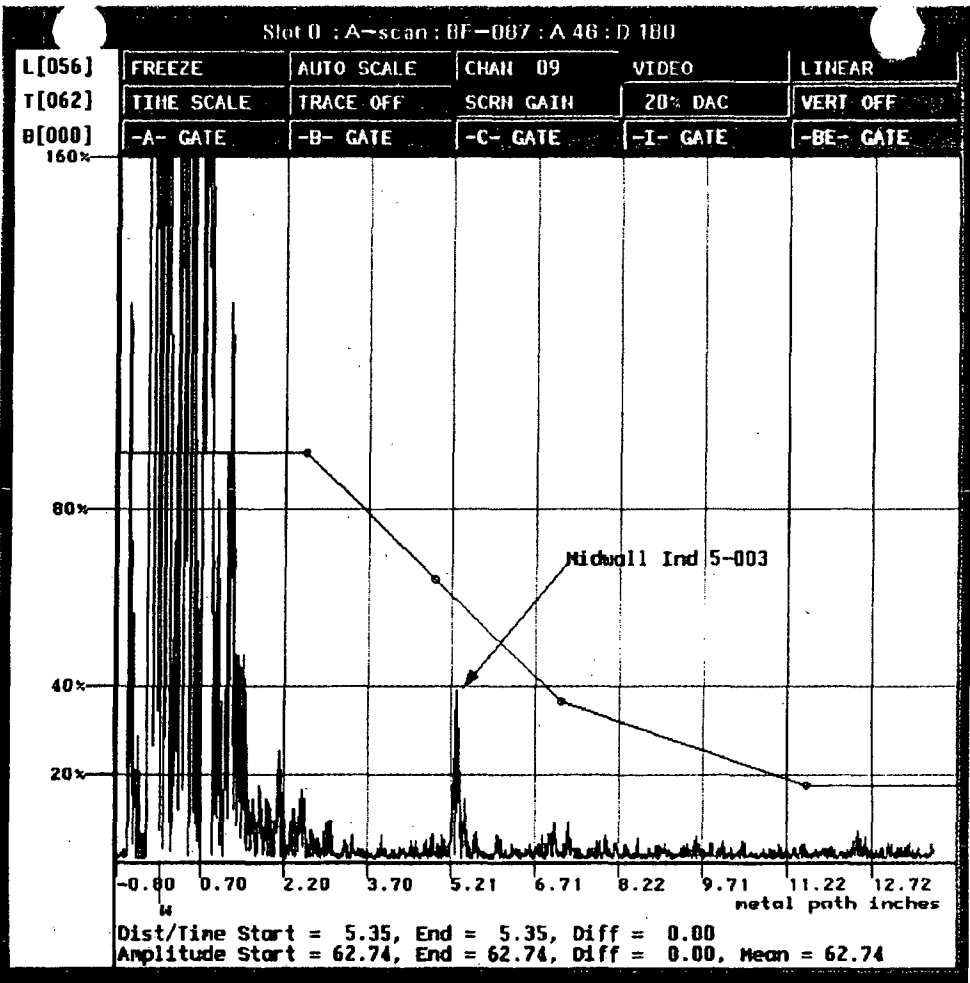

00026

Z 6 01 13

11/10

S 0 : Scale

32.3
36.6
41.0 100%
45.3 50%
49.7
54.0 20%
58.4
62.7
67.1
71.4
75.0
80.1
84.5
88.8
93.2

DAC

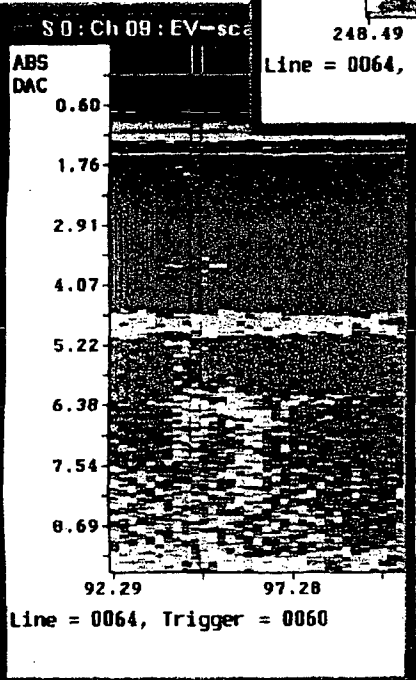
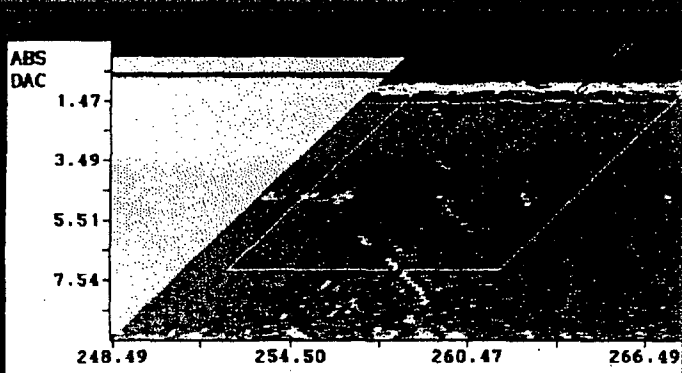
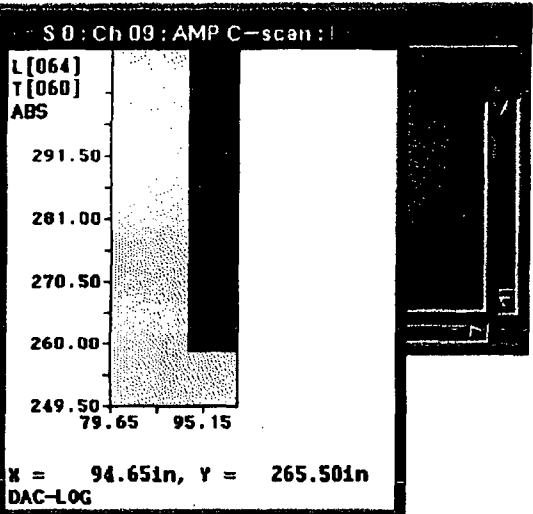

hpterm
axtor3/5-004

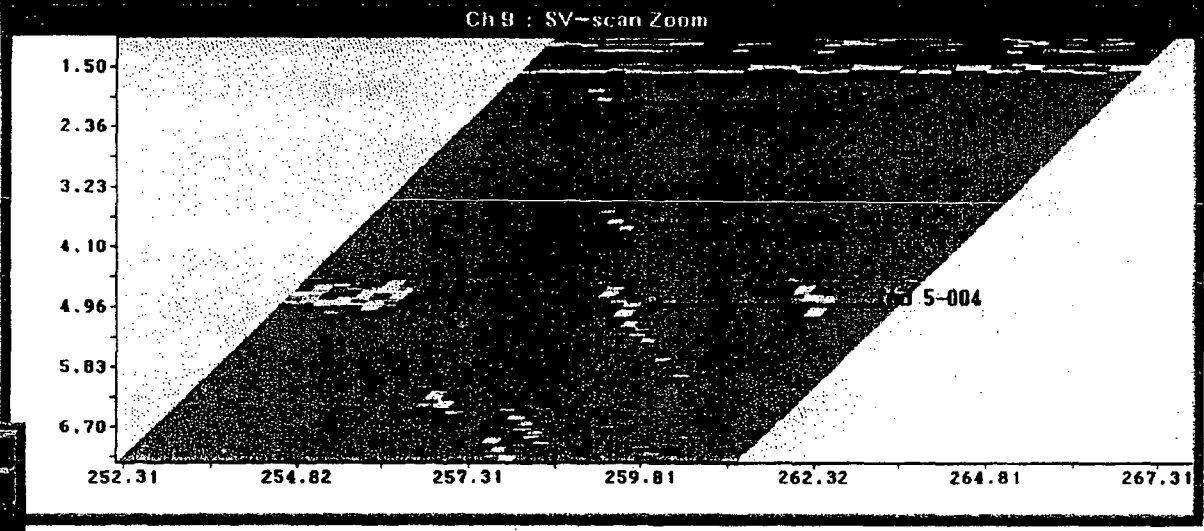
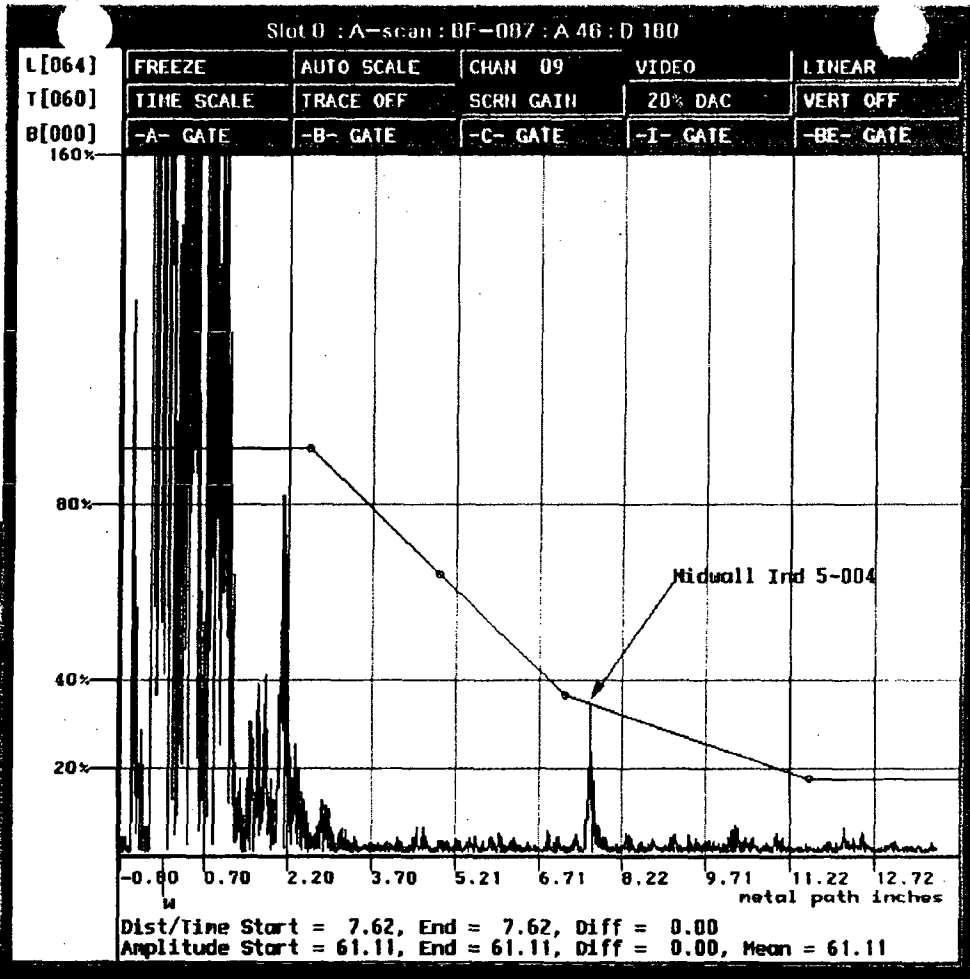

07105-113
00027

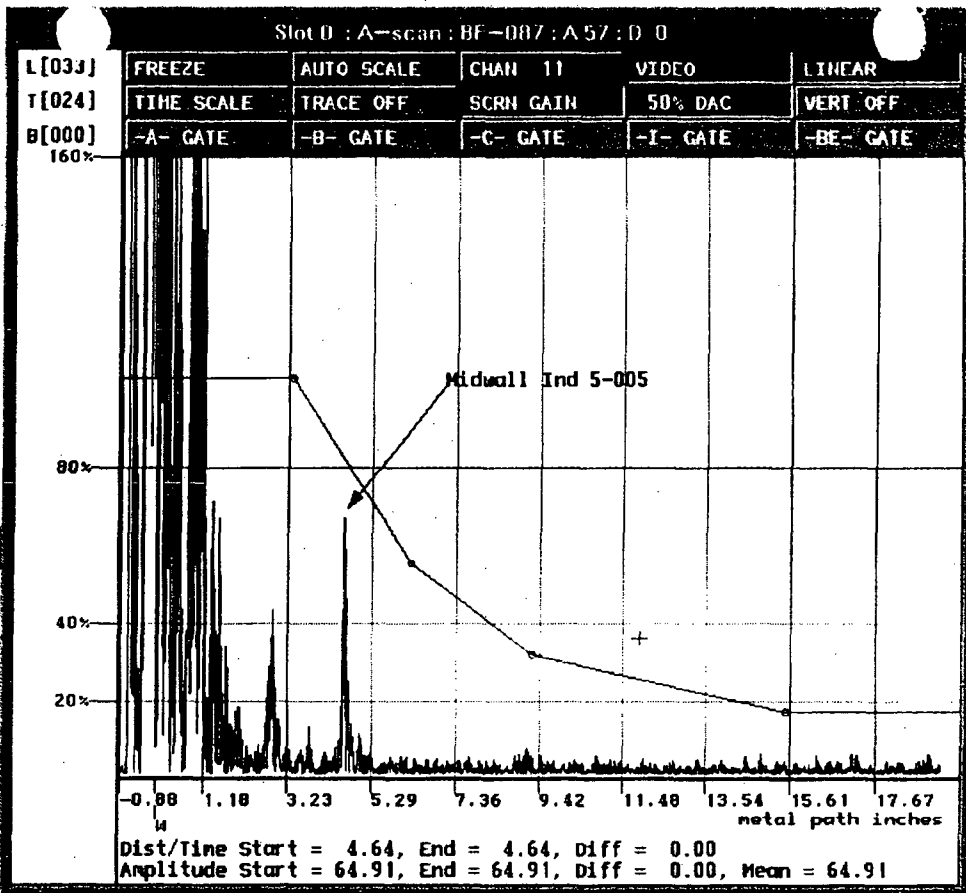
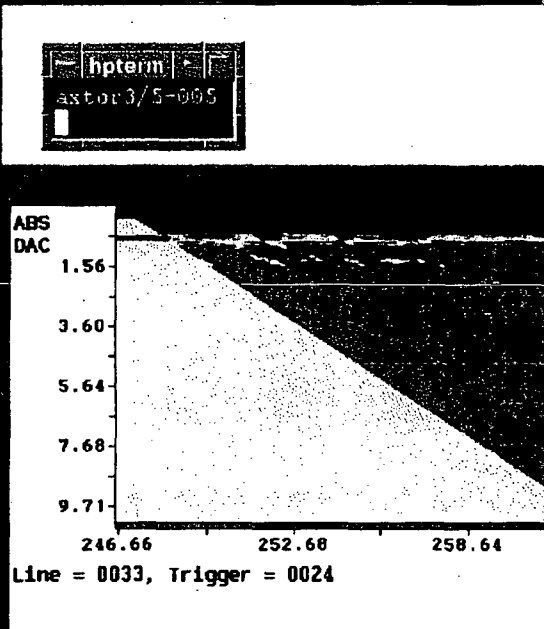
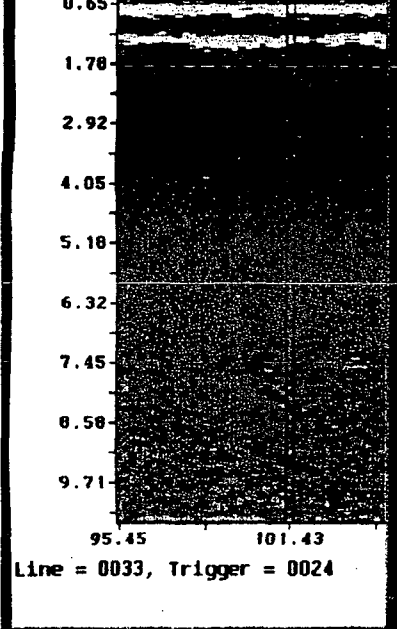
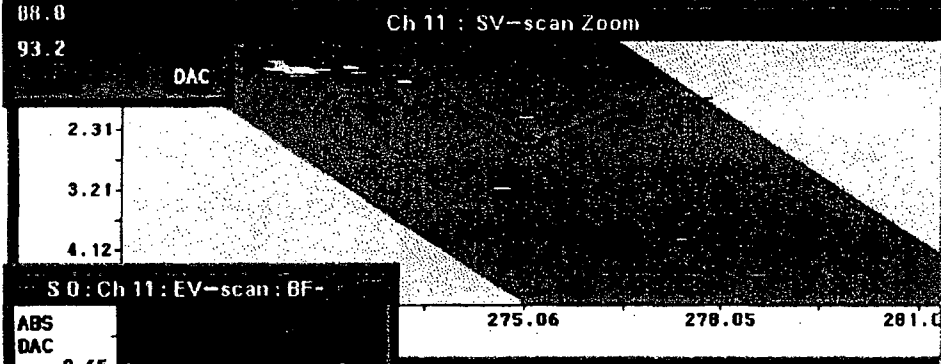
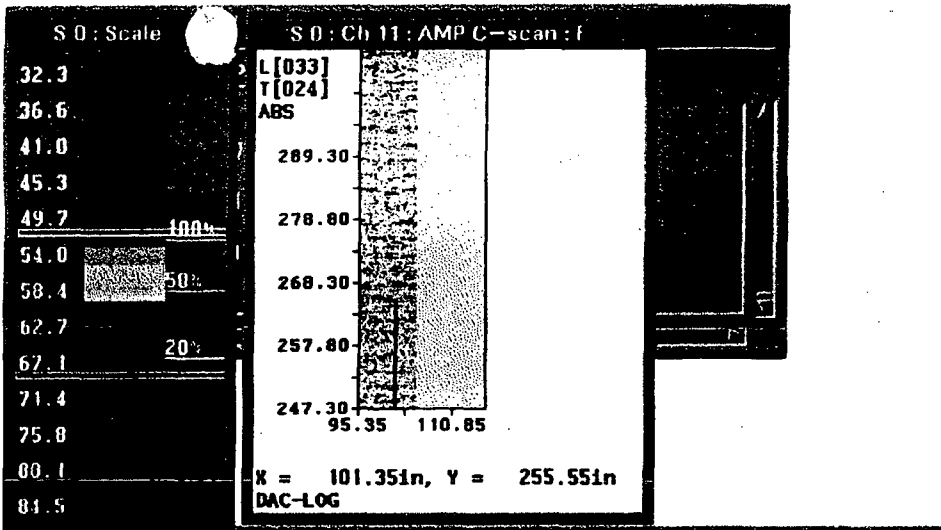

* 00028
2/8 of 43
R1100

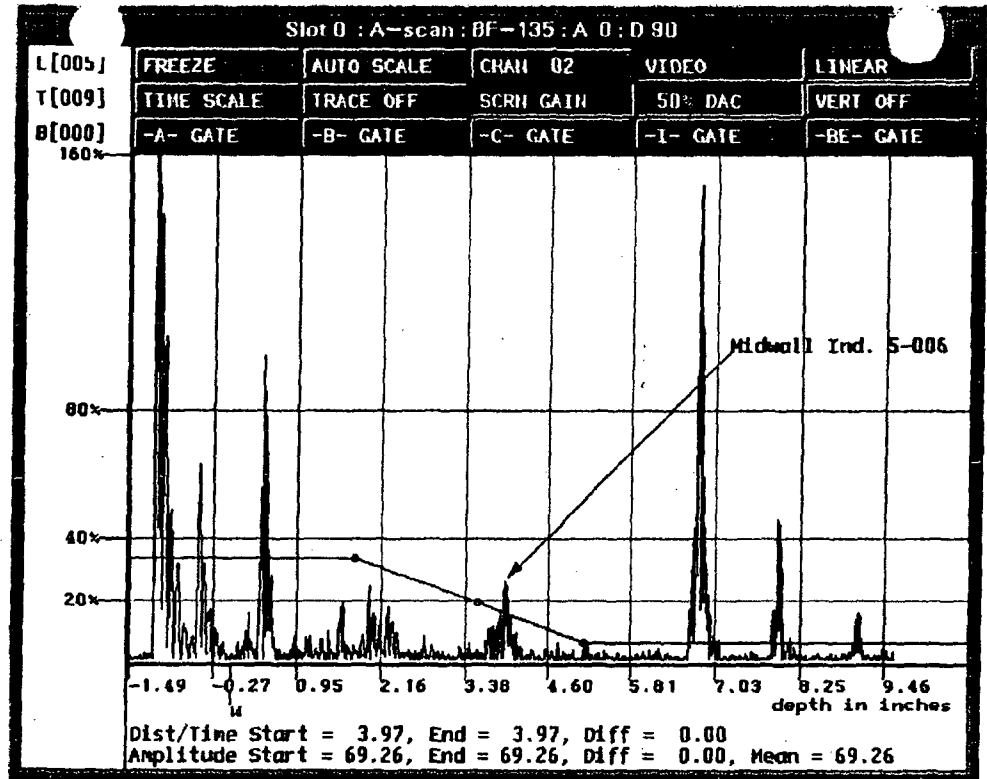
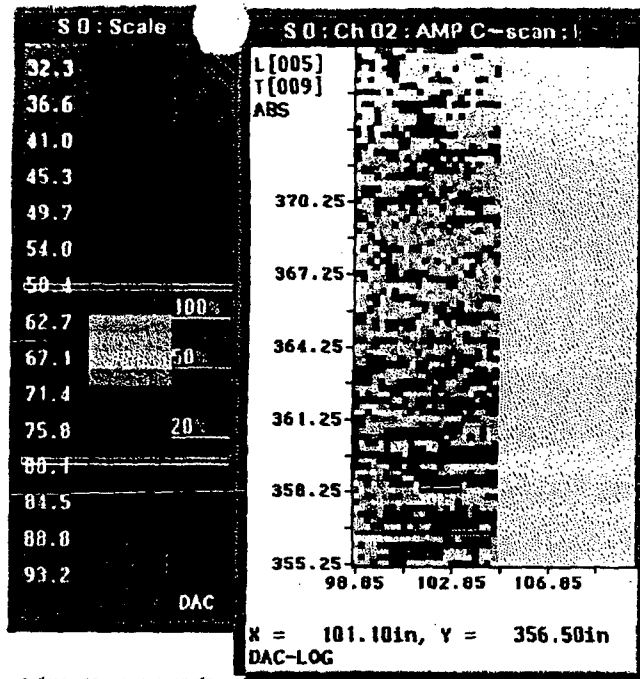

Top Terminal

06

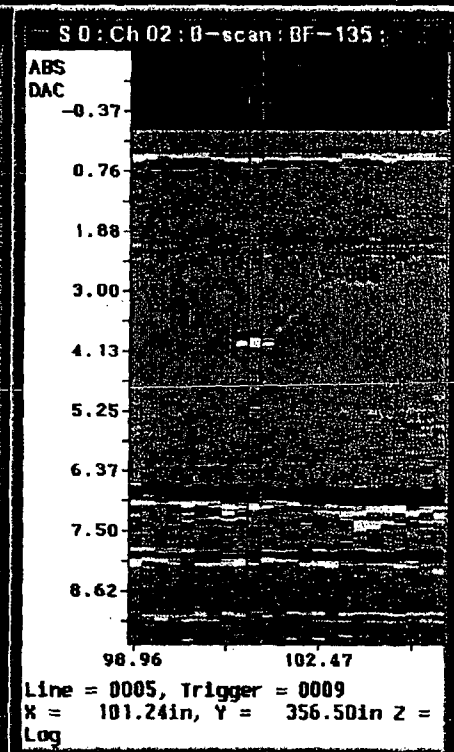
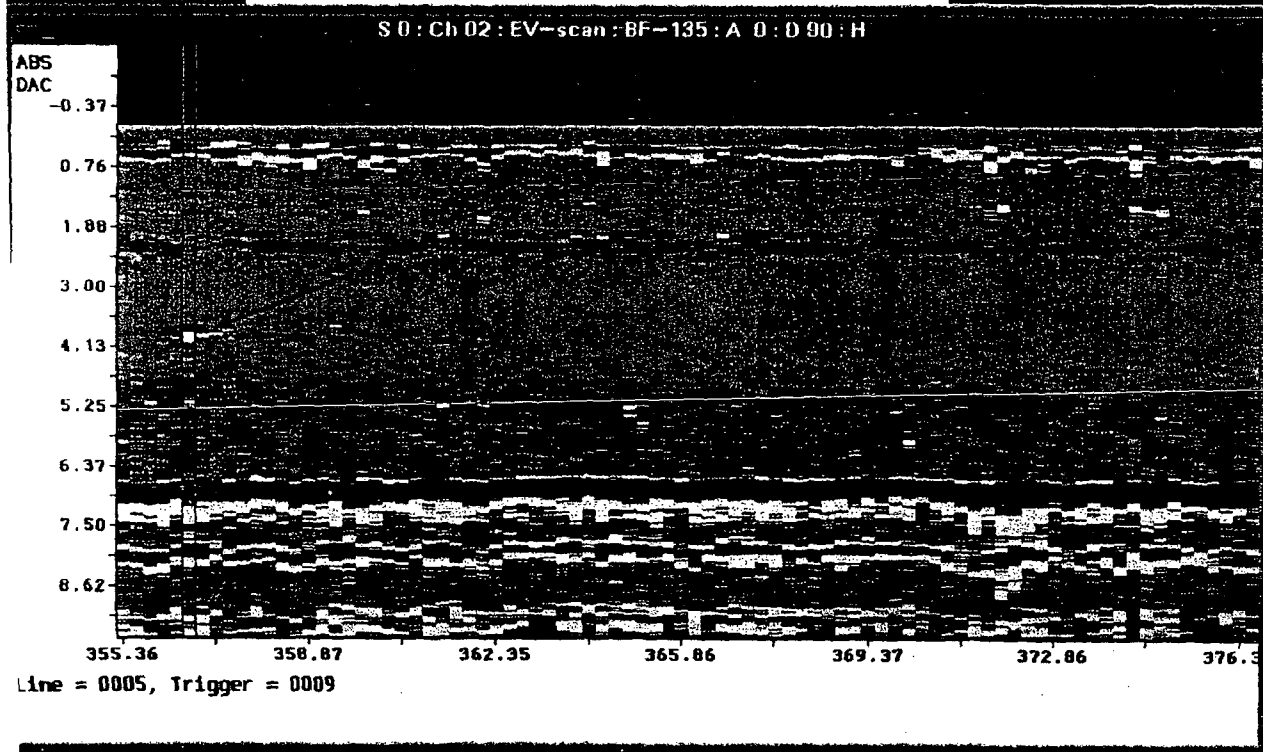

R1150
29 of 43
00029

S 0 : Scale

32.3
36.6
41.0
45.3
49.7
54.0
58.4
62.7
67.1
71.4
75.8
80.1
84.5
88.8
93.2

100%
50%
20%

DAC

S 0 : Ch 10 : AMP C-scan : I

L[045]
T[003]
ABS

370.25
367.25
364.25
361.25
358.25
355.25

93.15 97.15 101.15

X = 93.90in, Y = 366.50in
DAC-LOG

Top Terminal
or3/5-007

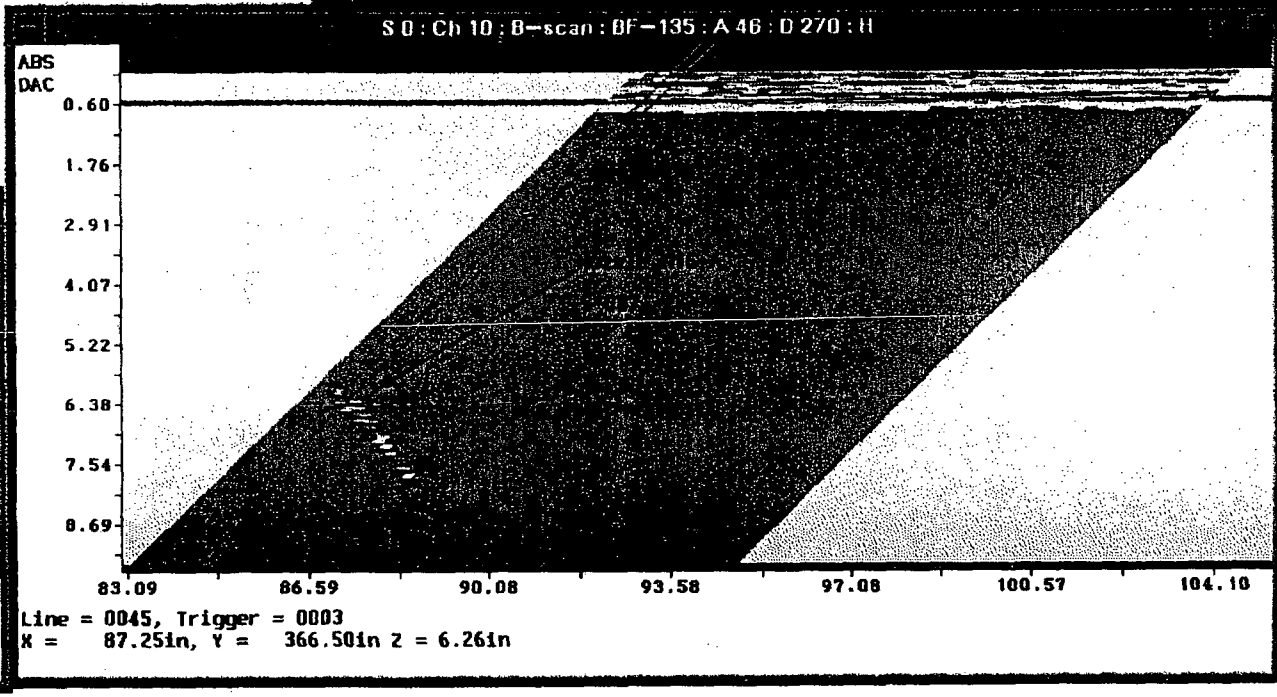
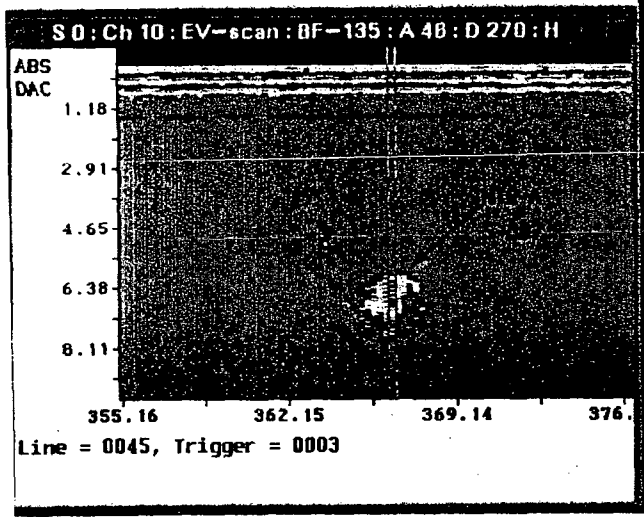
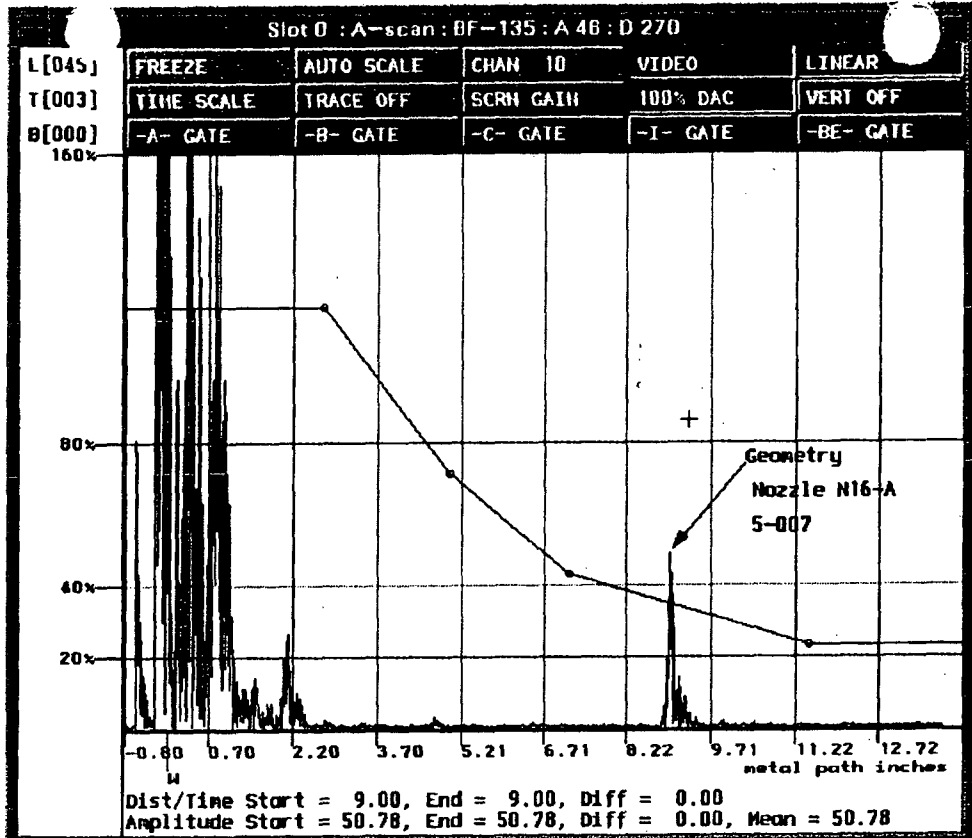

00000 000
 00030
 30 OF 43
 R1160

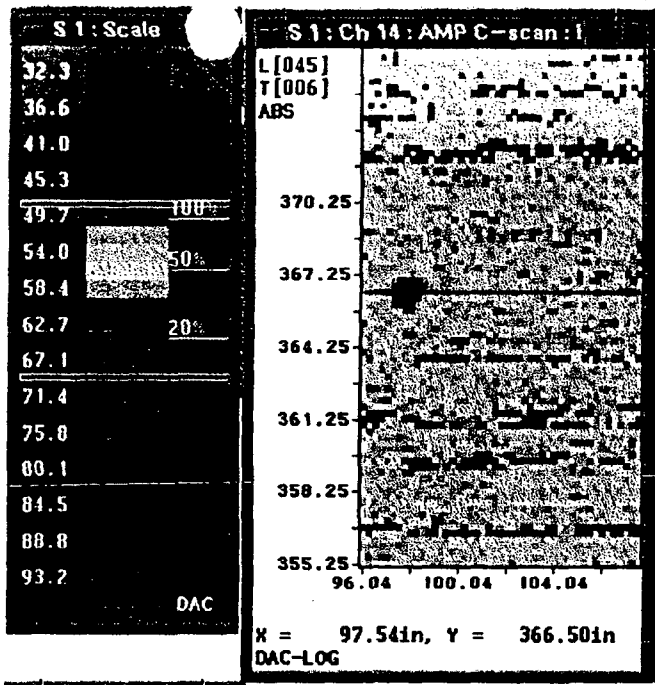

Top Terminal
or 3/5-008

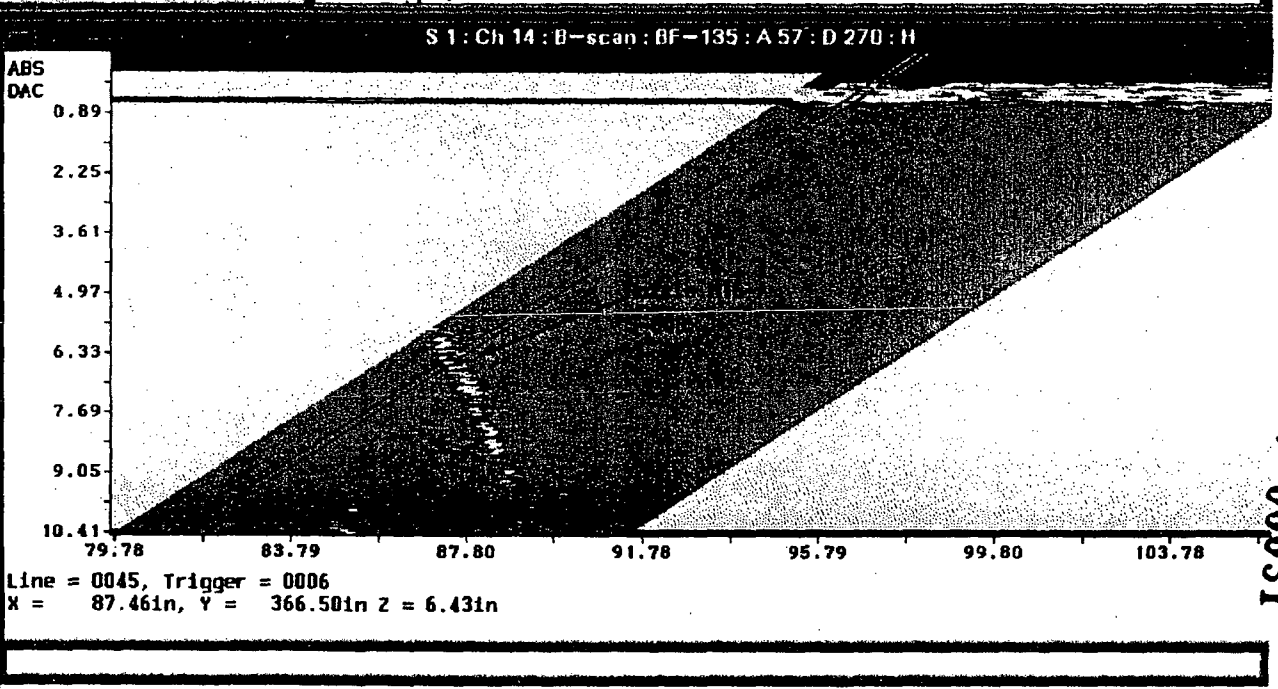
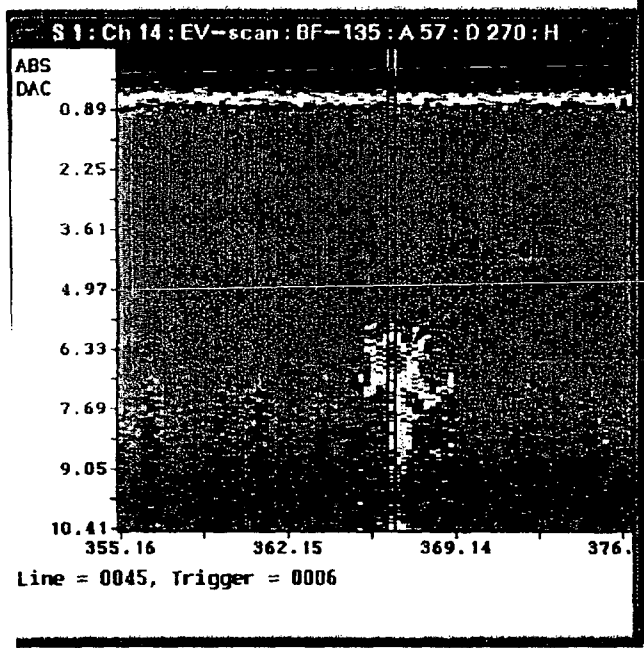
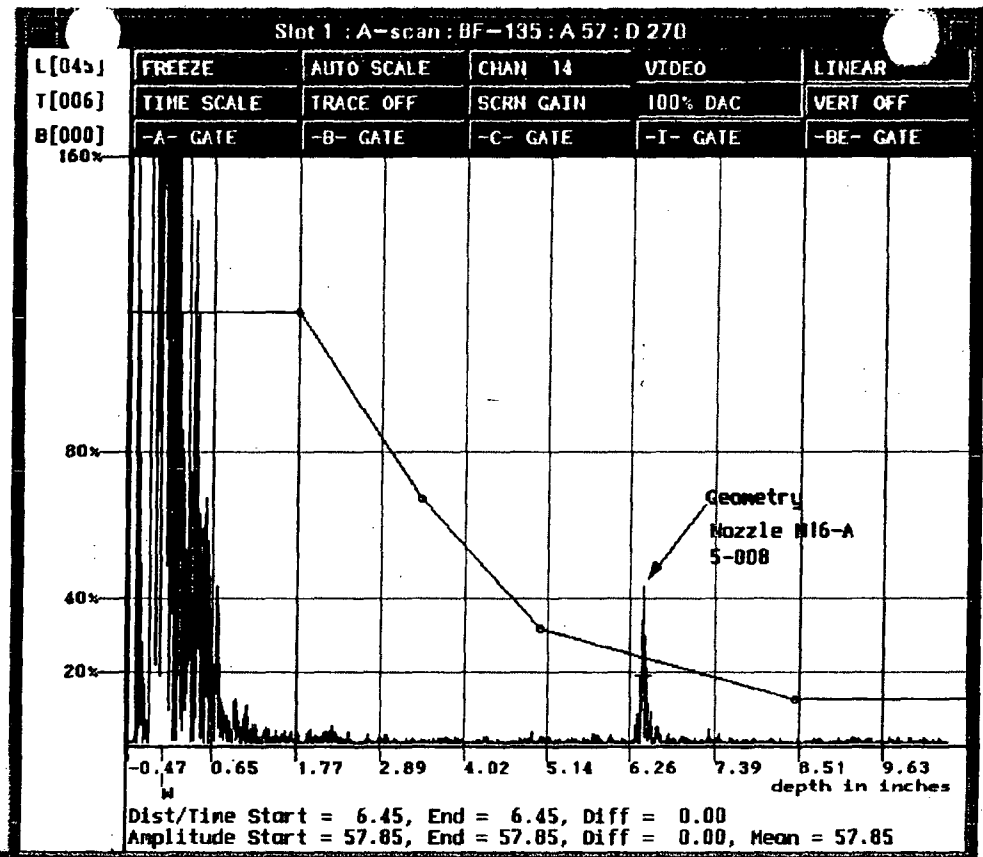

21160
310543
00031

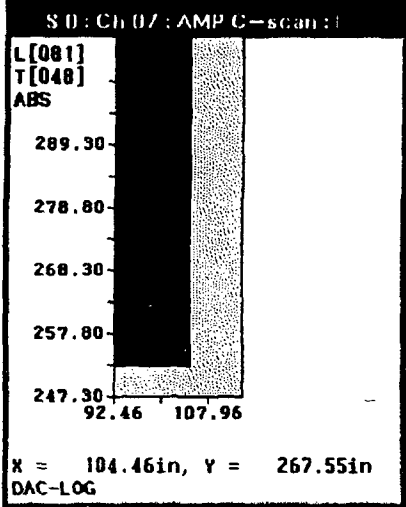
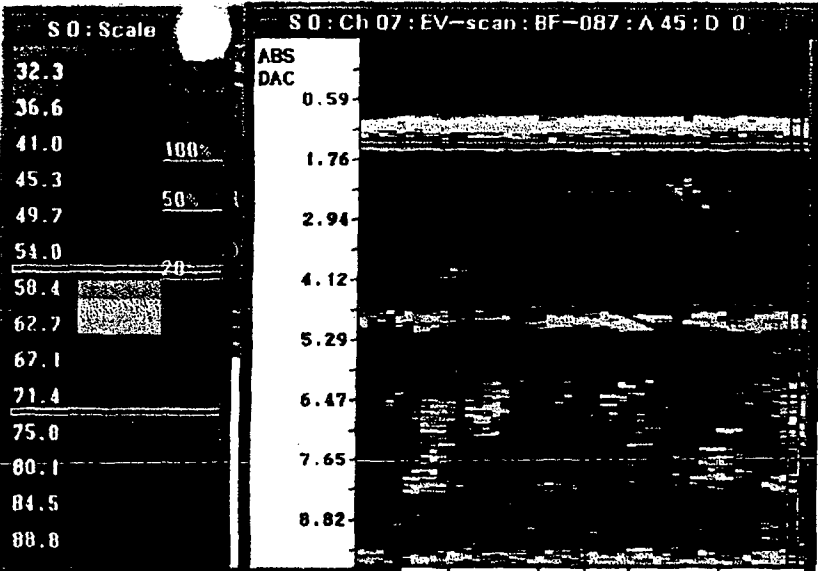

97.58 102.57
Trigger = 0048

hpterm
actor 3/G-001

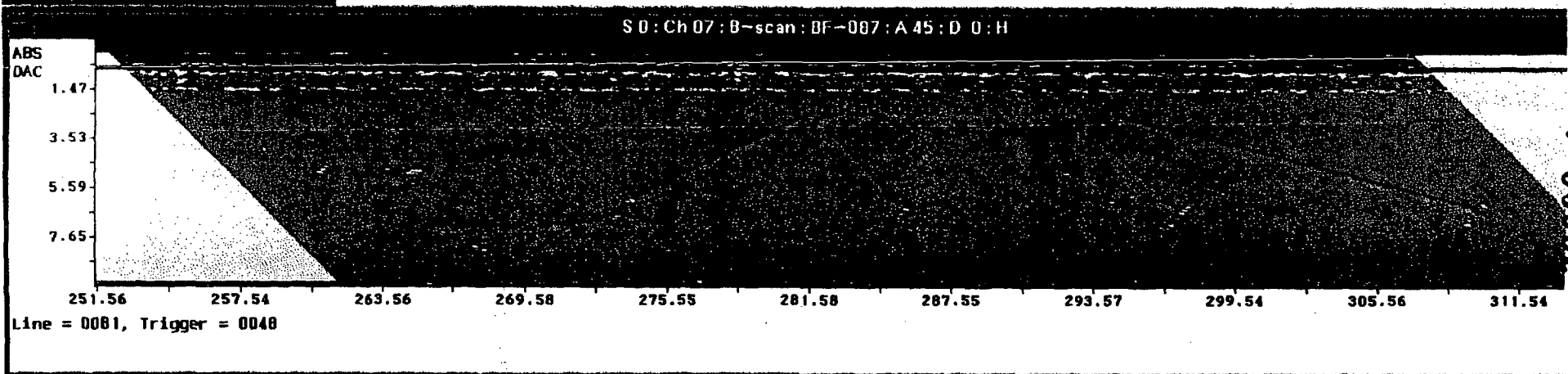
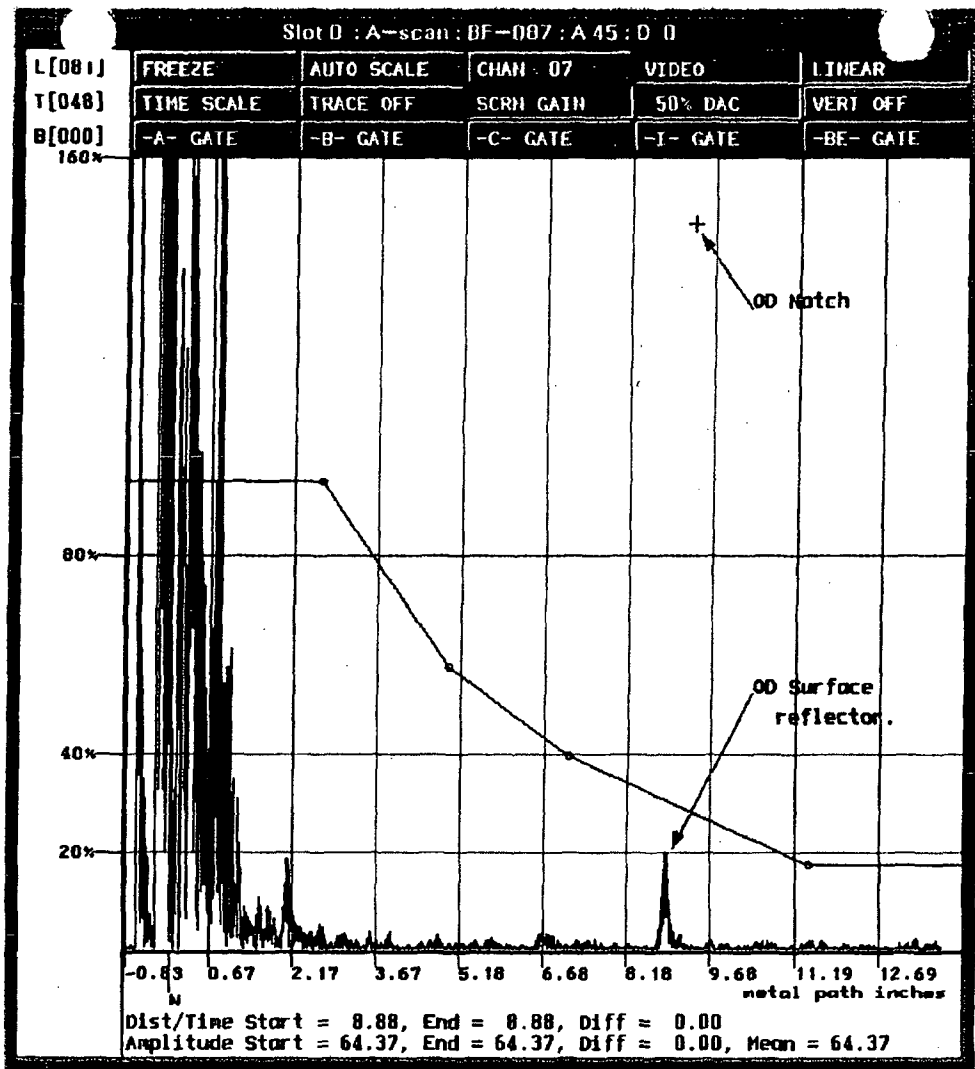

0000 0484

32.0243

2160

00032

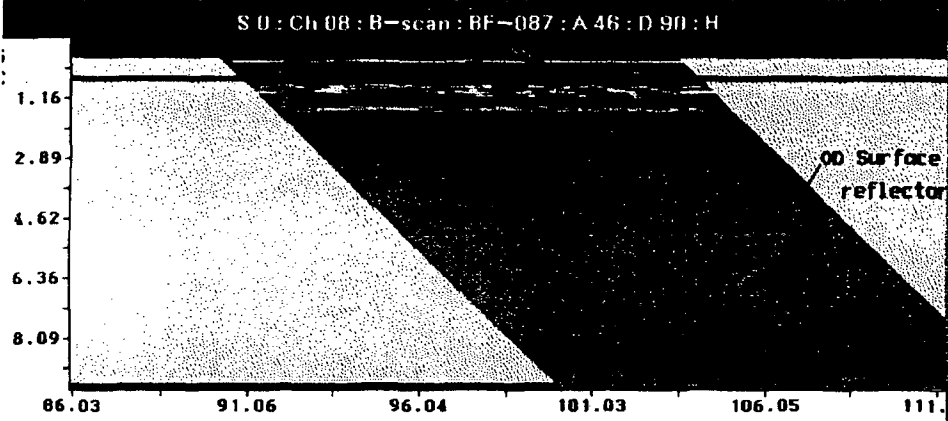
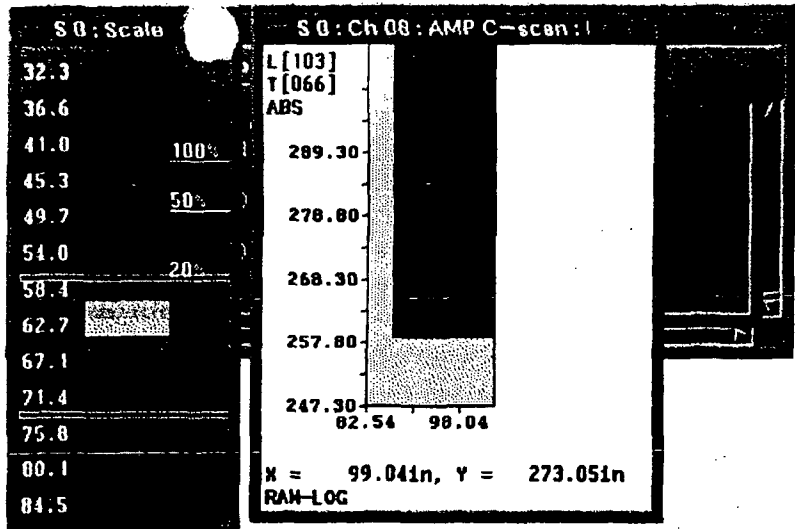

ie = 0103, Trigger = 0066
105.53in, Y = 273.05in Z = 6.27in

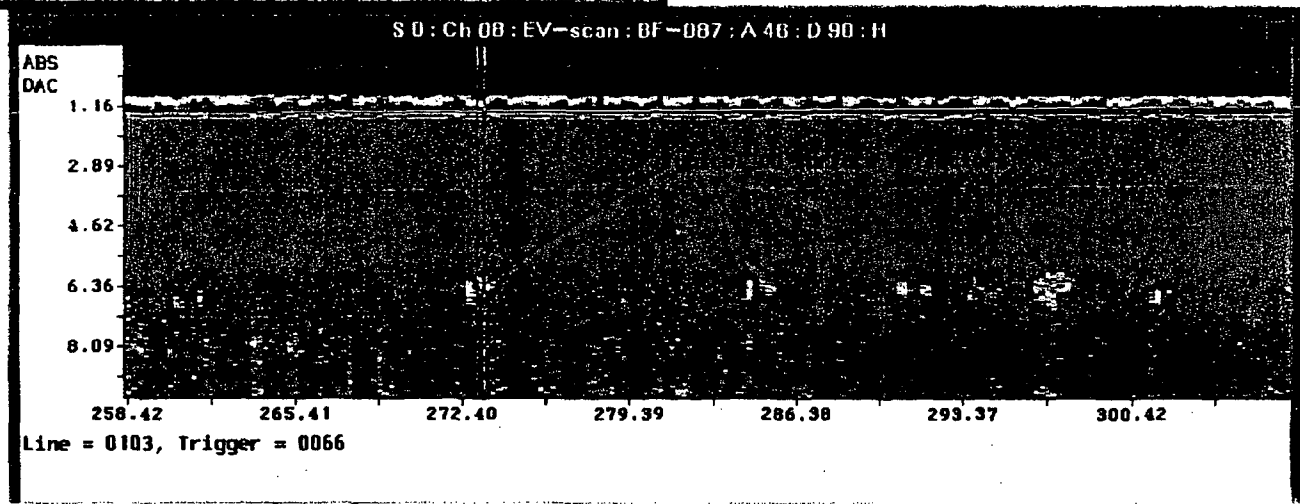
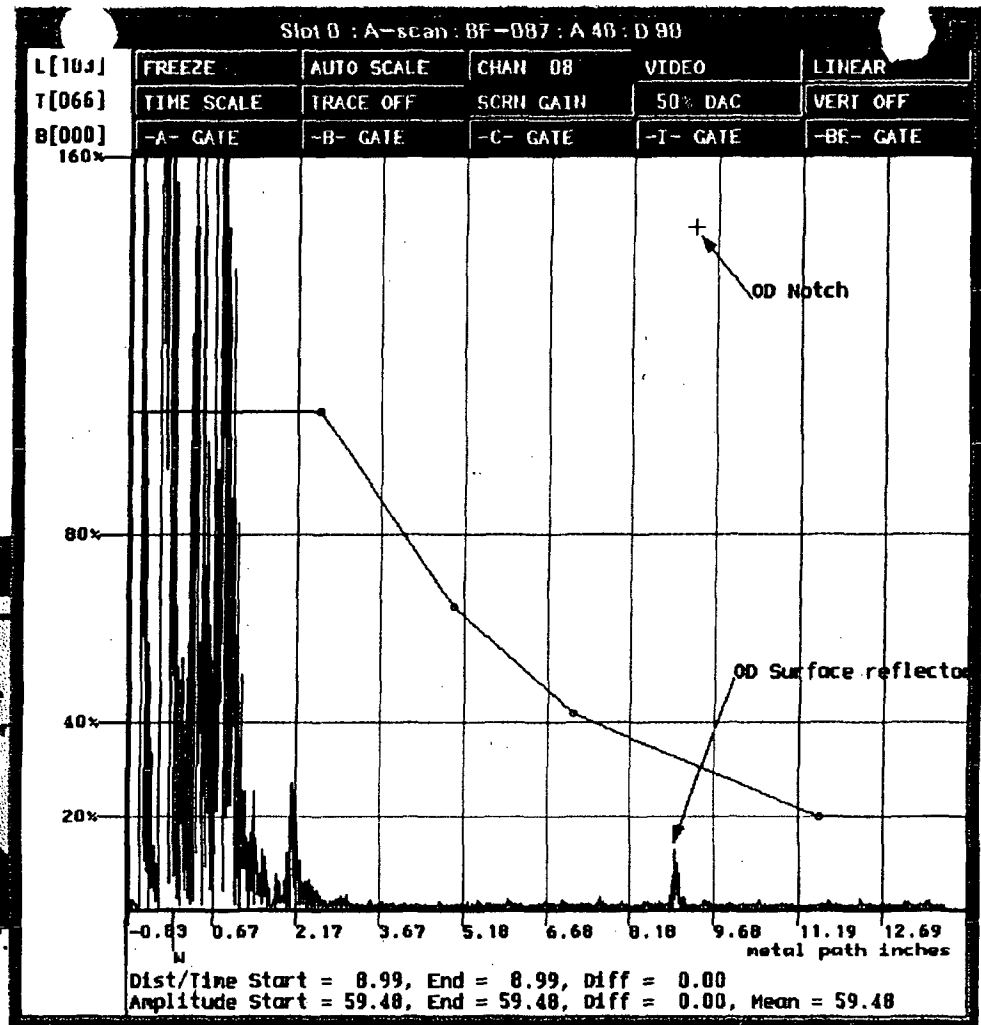

hpterm
actor3/G-002

33 of 43
R1100
00033

S 0 : Scale

32.3
36.6
41.0
45.3
49.7
54.0
58.4
62.7
67.1
71.4
75.8
80.1
84.5
88.8
93.2

100%
50%
20%

DAC

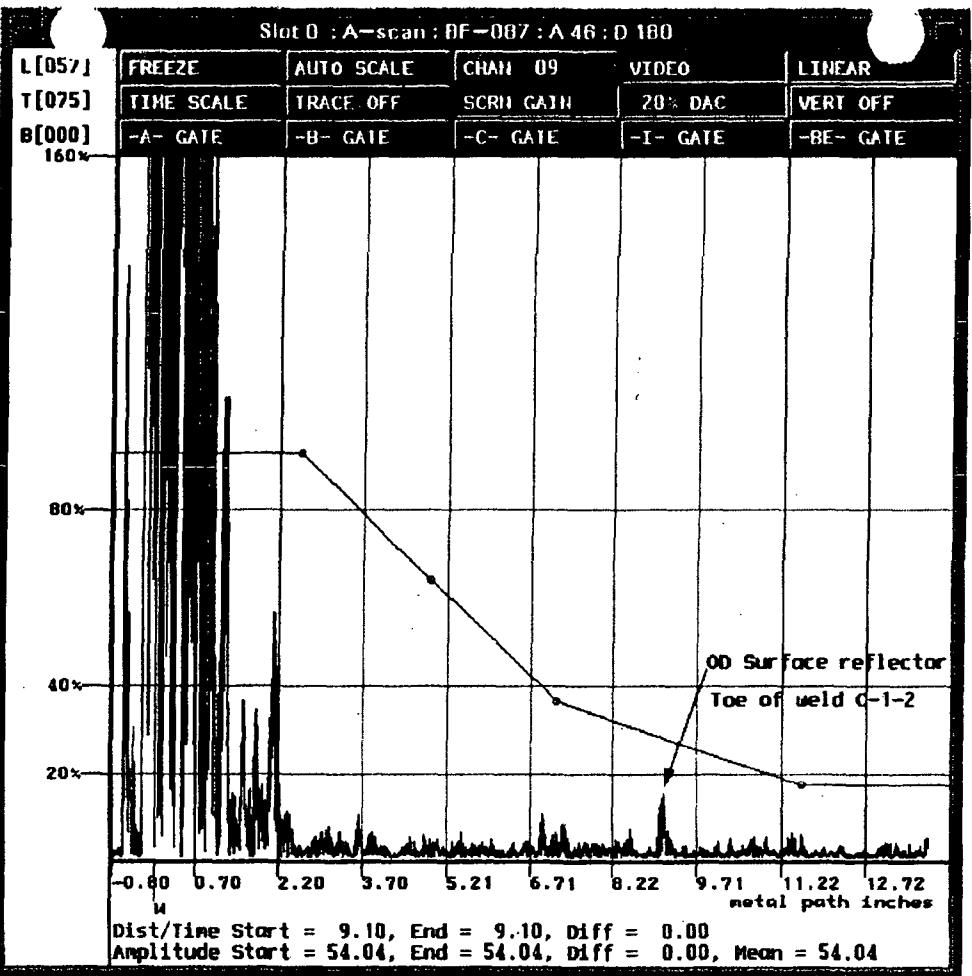
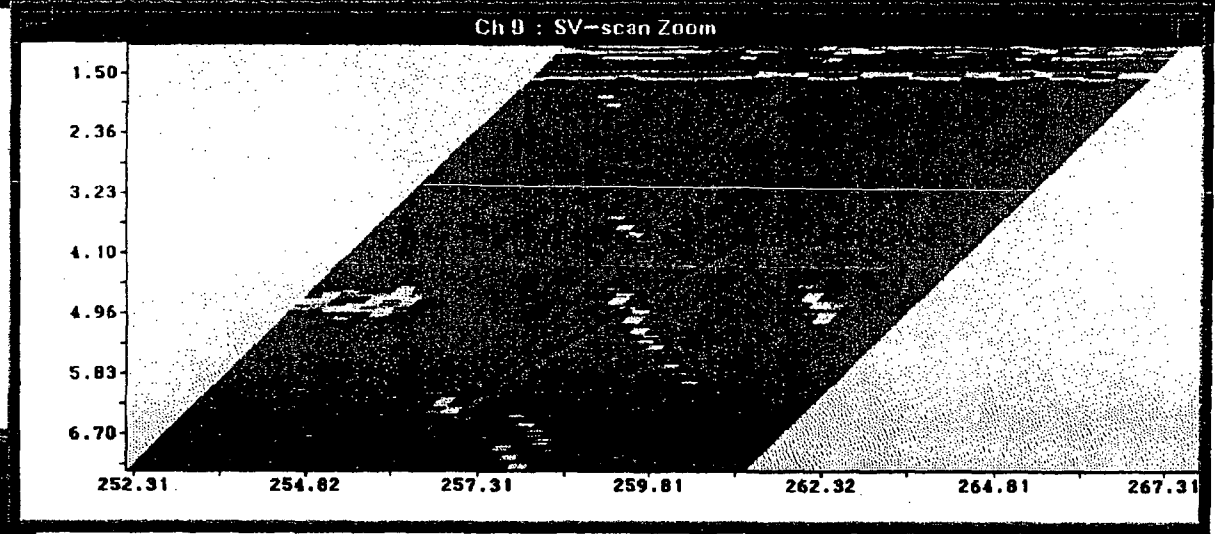
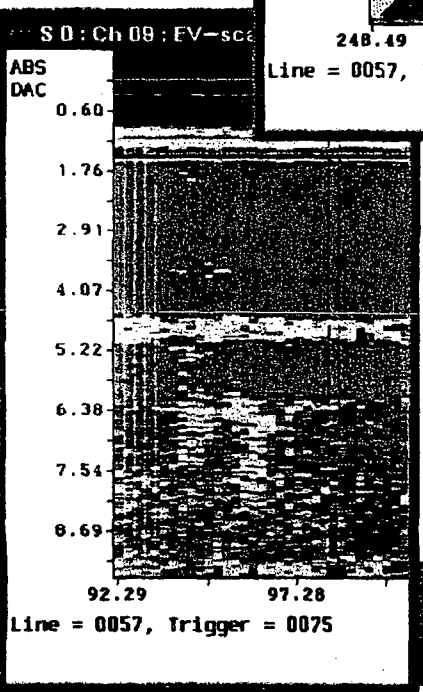
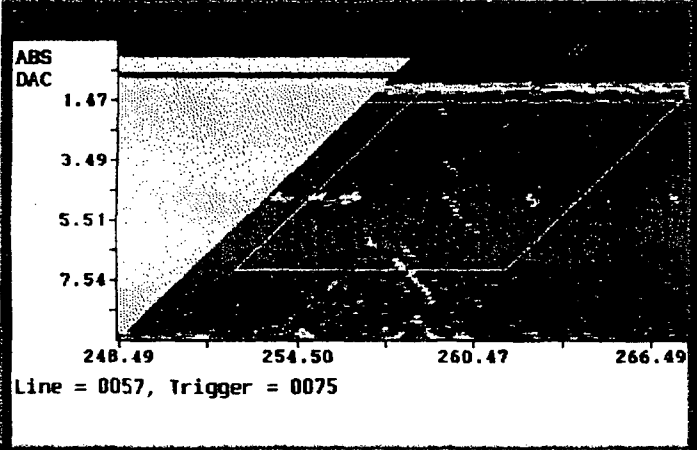
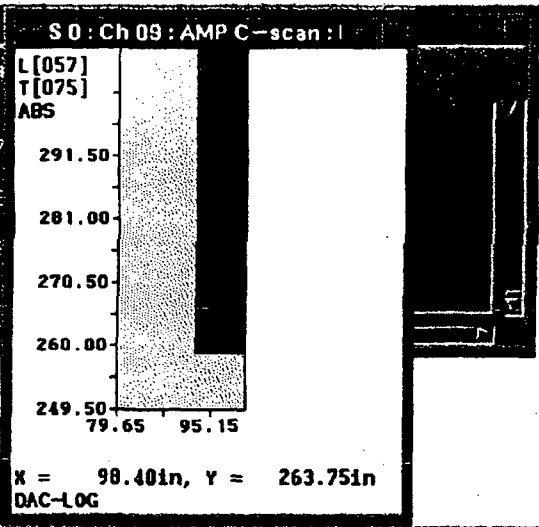

R11.50
34 of 43
00034

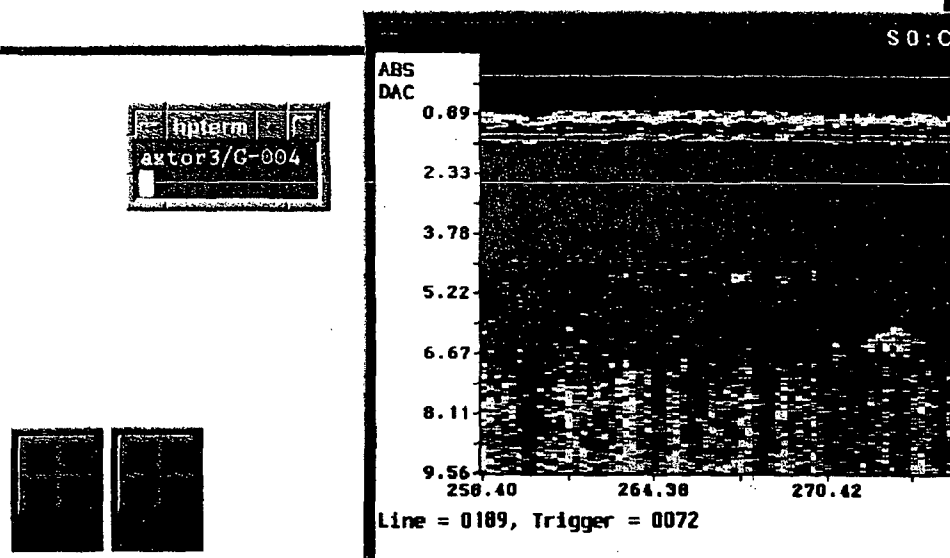
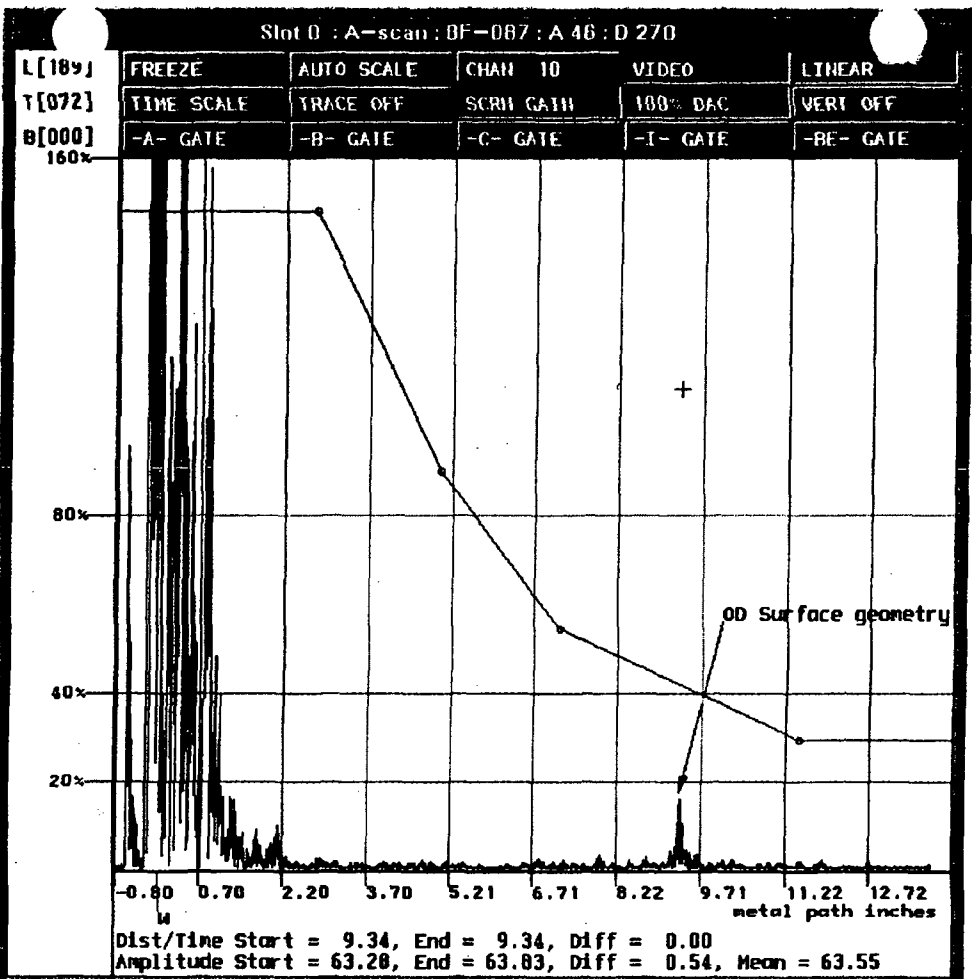
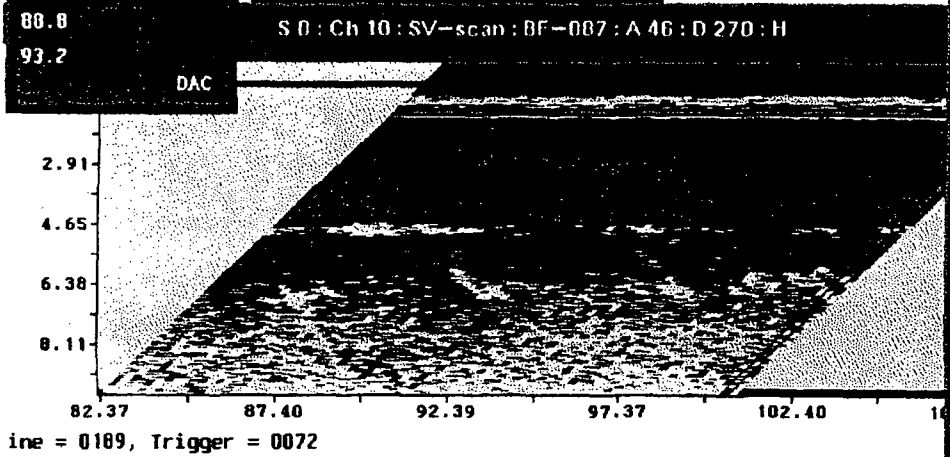
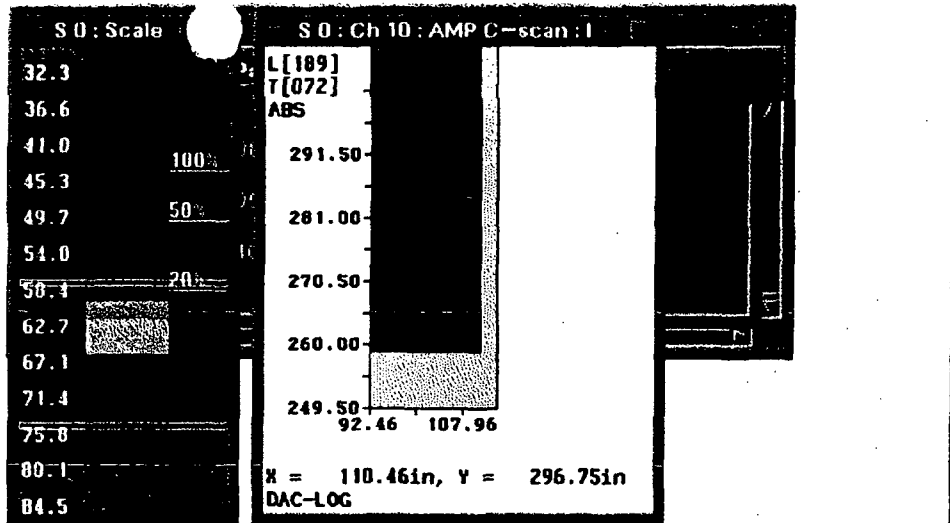

Interm
actor 3/G-004

K1190
35 of 43
00035

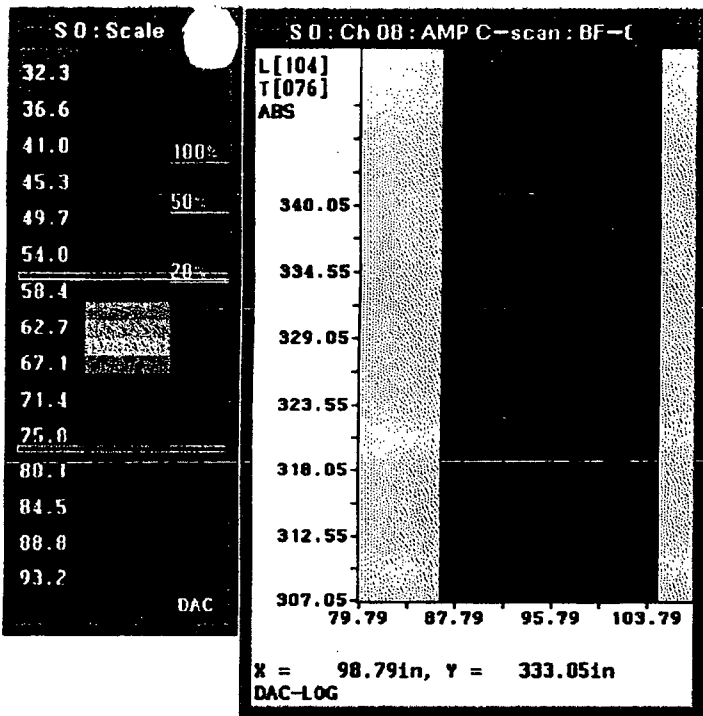

hpterm
ump

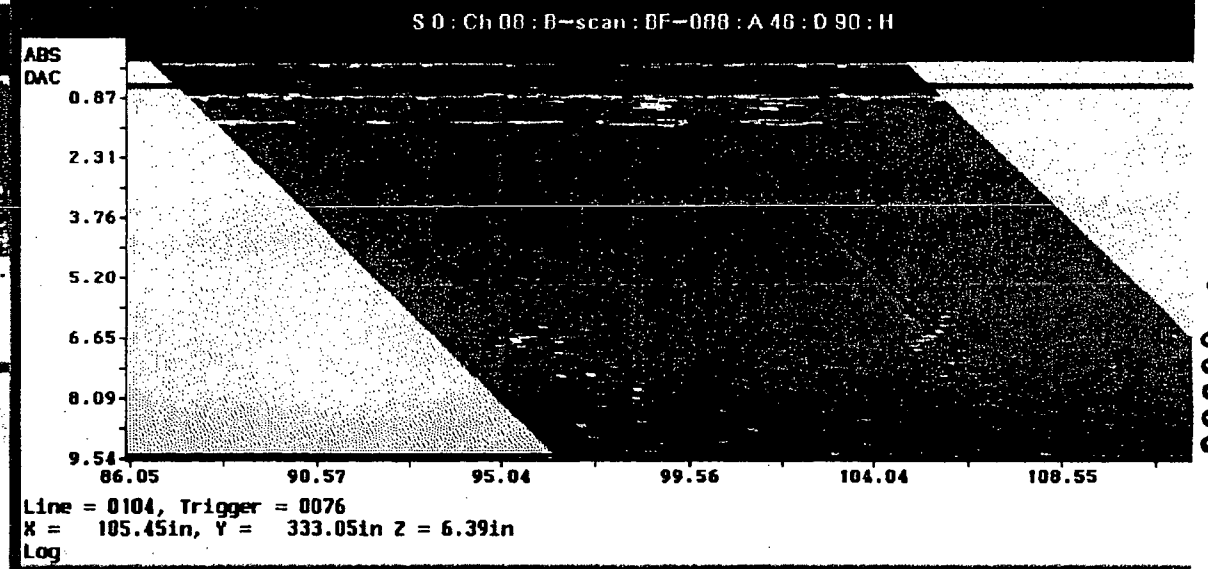
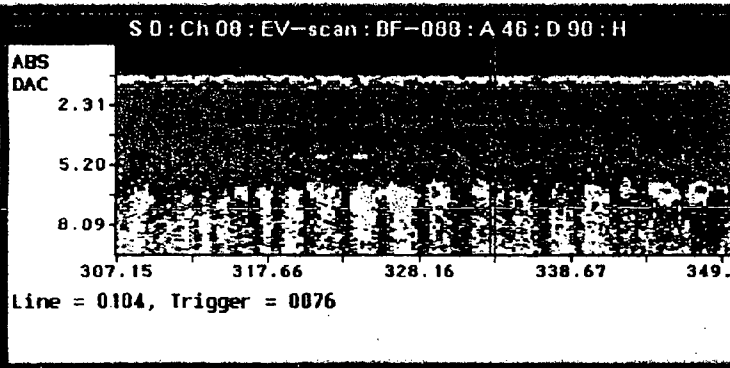
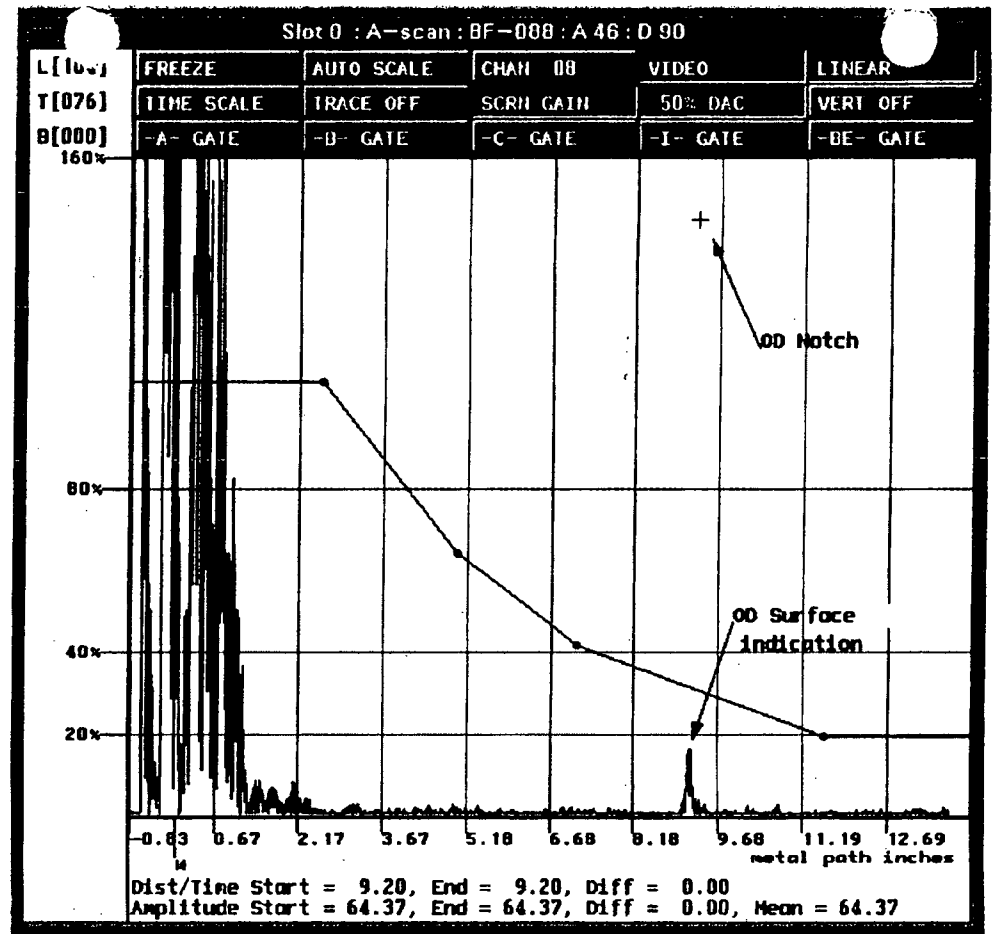

36 of 43
R1100
00036

32.3
36.6
41.0
45.3
49.7
54.0
58.4
62.7
67.1
71.4
75.8
80.1
84.5
88.8
93.2

100%
50%
20%

DAC

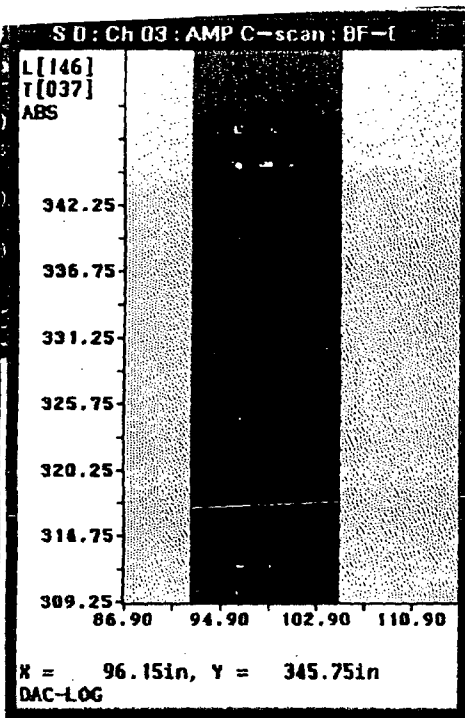

hpterm
autor3/G-006

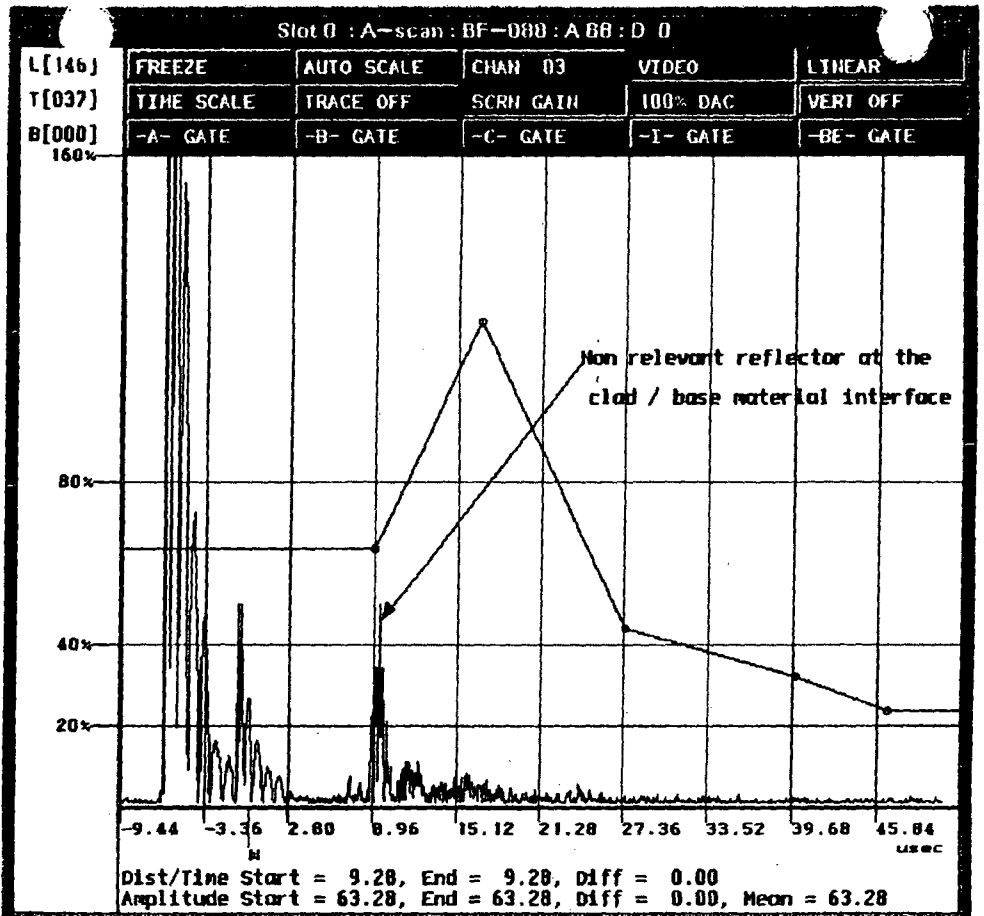

00000 00001

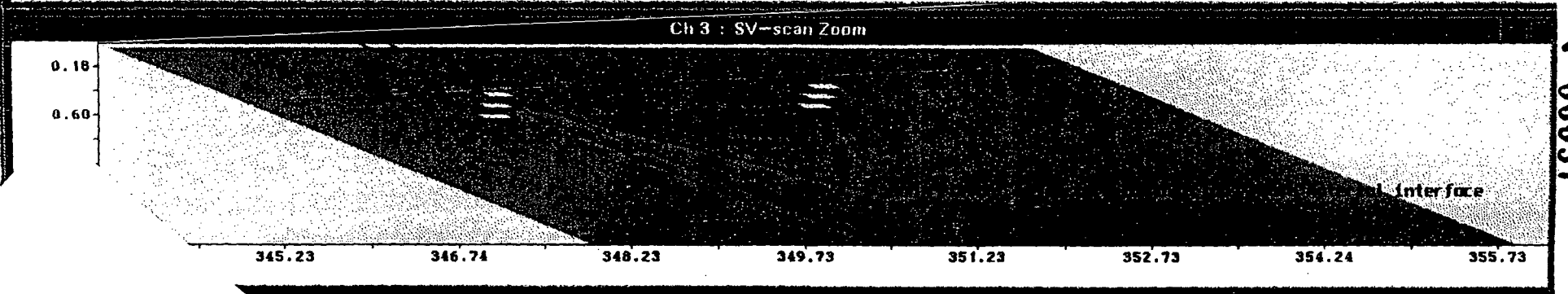
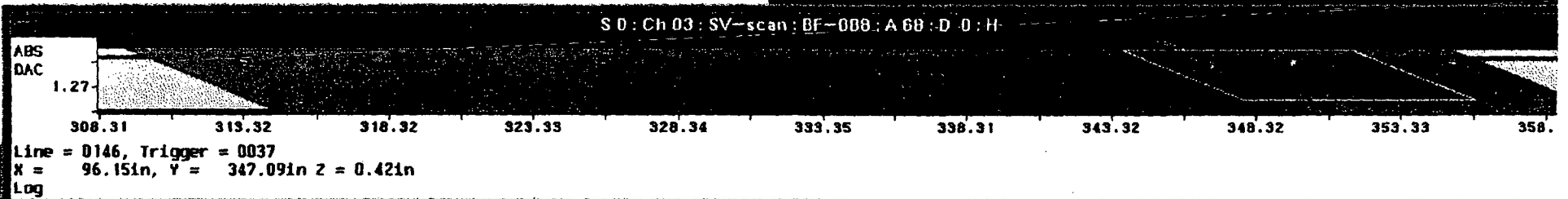

R1160
37 of 43
← 00037

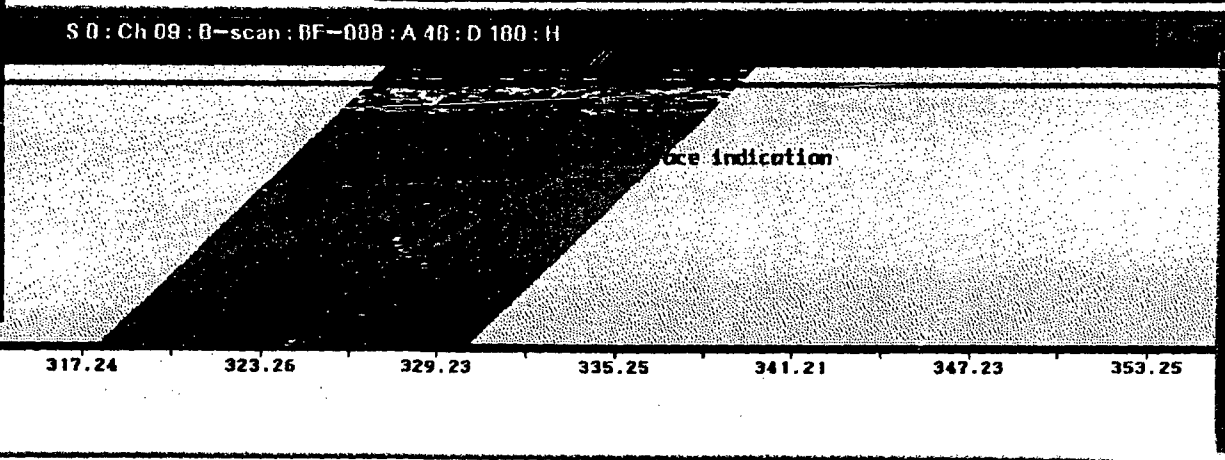
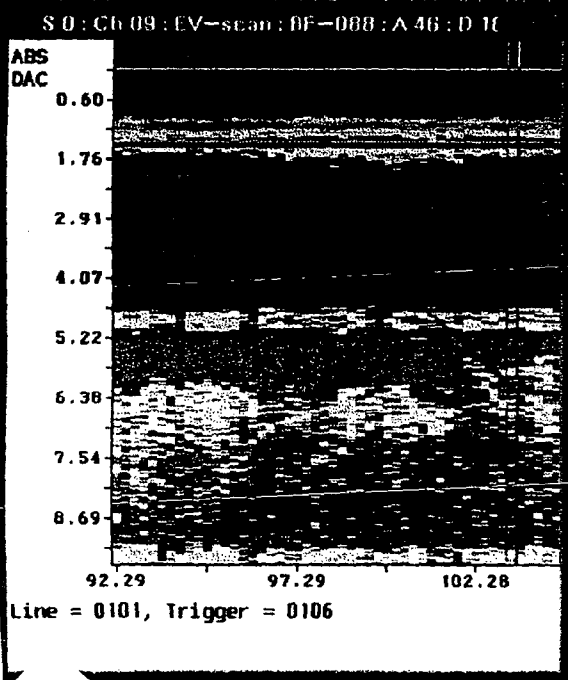
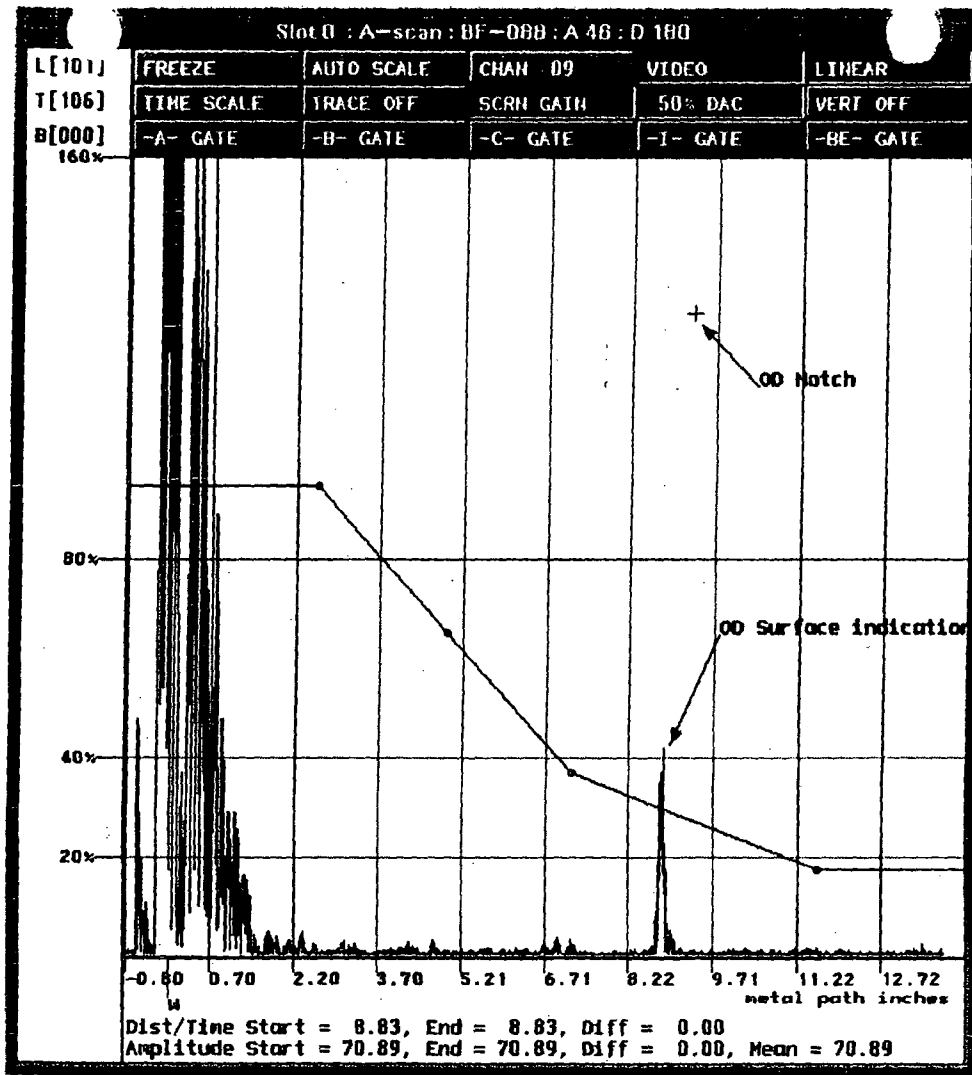
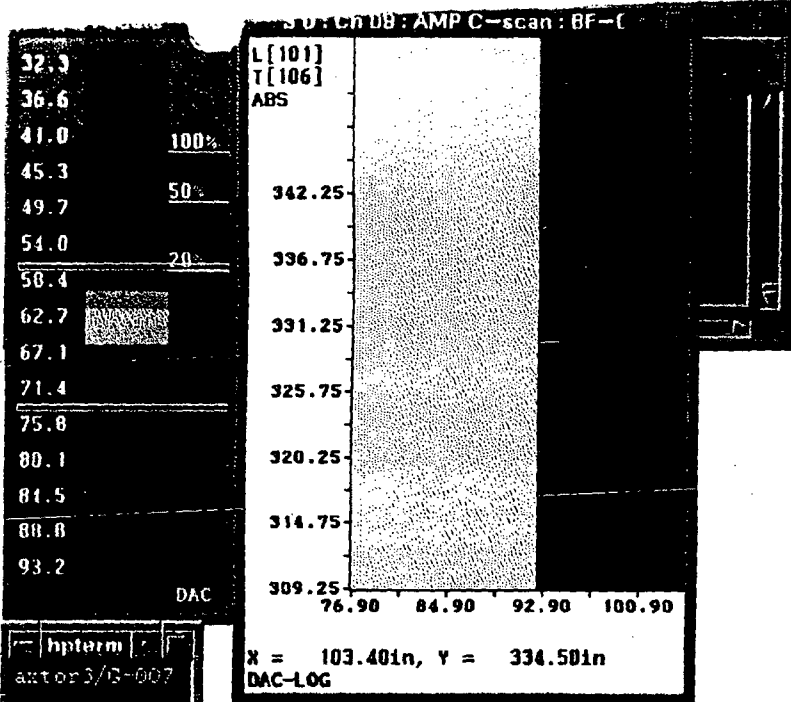

R1160
 38 of 43
 00038

S O : Scale

32.3
36.6
41.0
45.3
49.7
53.0
58.4
62.7
62.1
71.4
75.8
80.1
84.5
88.8
93.2

DAC

hpterm
 auto 3/G-008

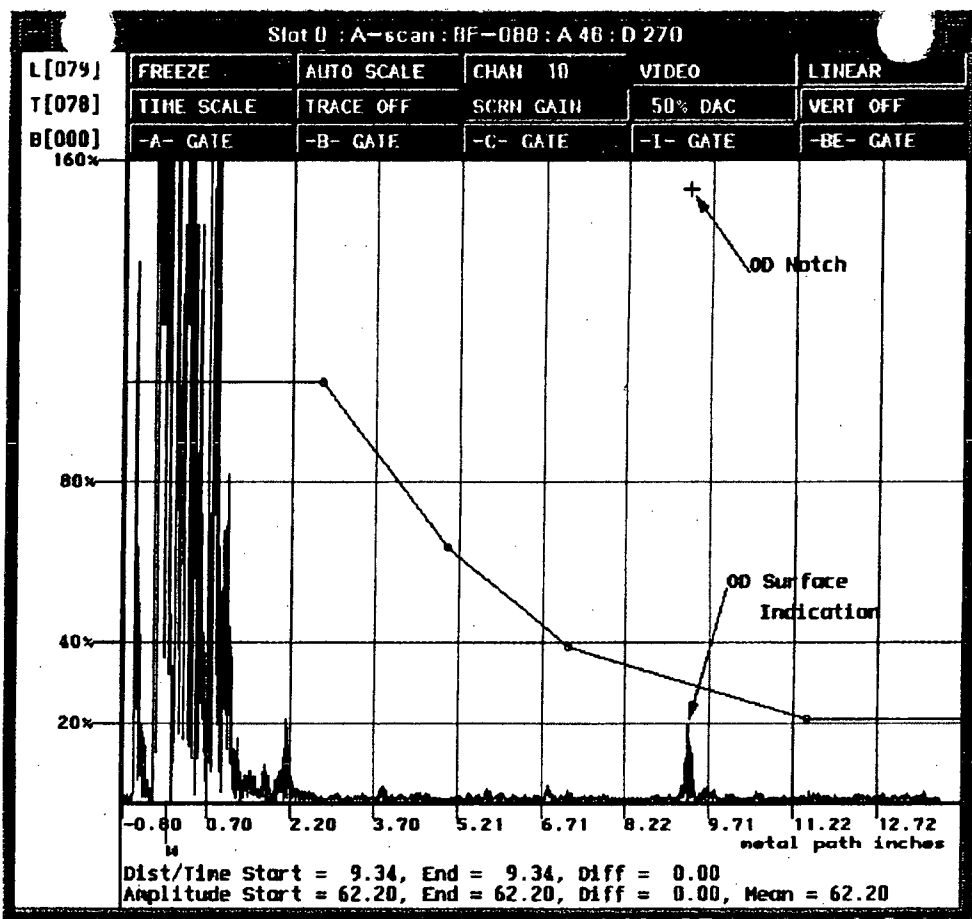
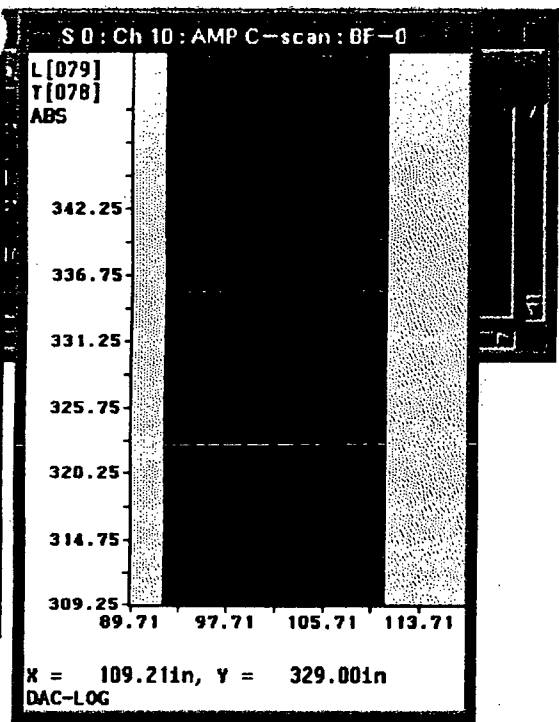

S O : Ch 10 : EV-scan : BF-088 : A 46 : D 270 : H

S
 C

2.91
6.38

309.20 321.18 333.16 345.14

ne = 0079, Trigger = 0078

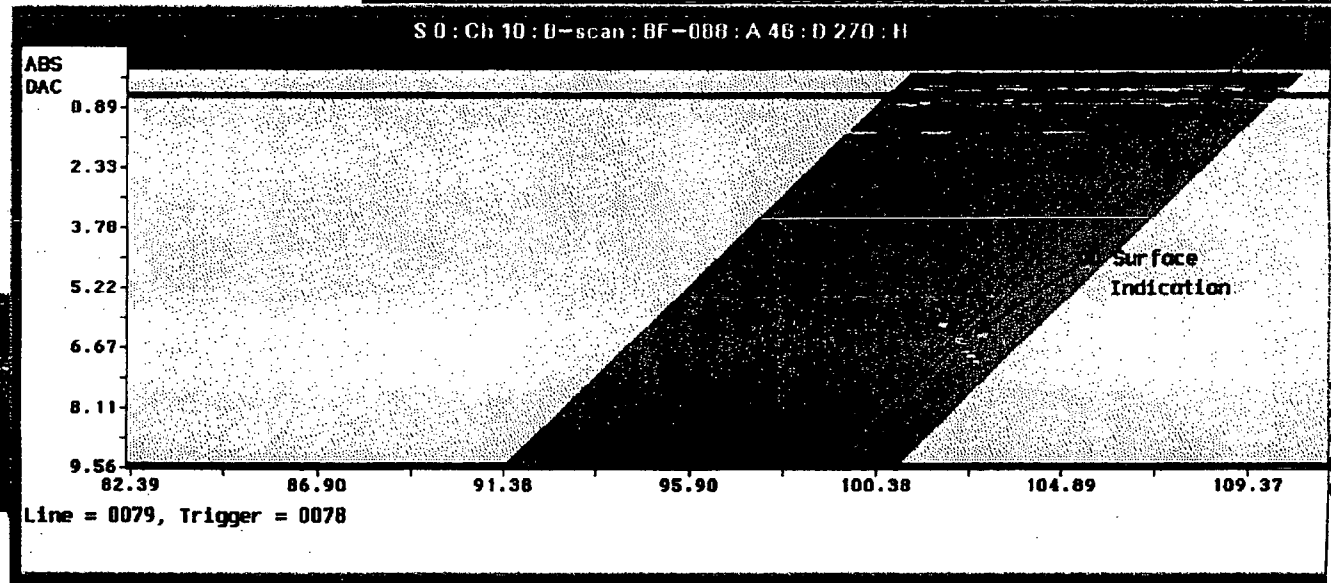

39 of 43
 : 00039
 K1160

BROWNS FERRY UNIT-3 WELD LOCATIONS

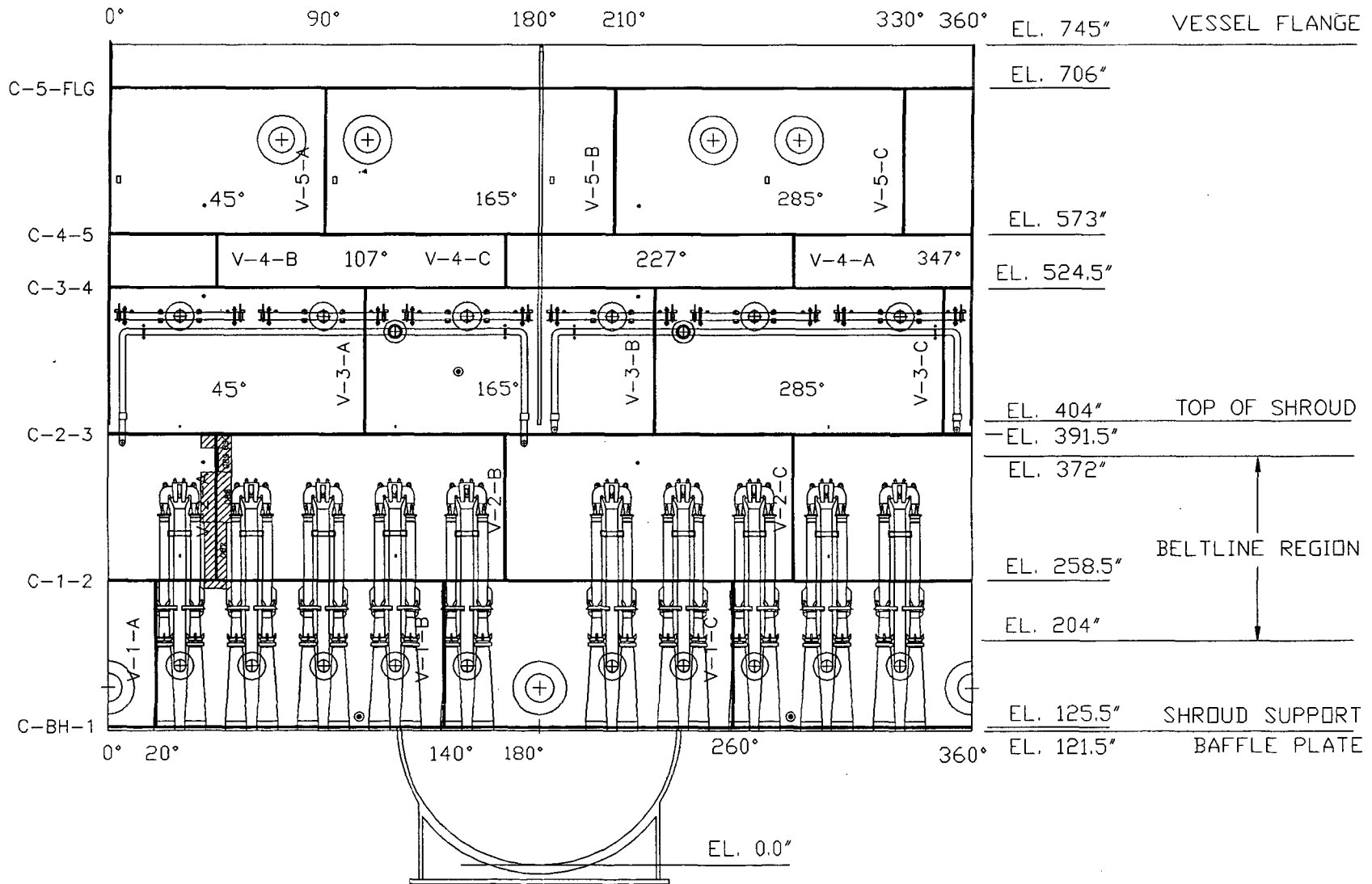

0000 0000
 00040 40 OF 43
 R1160

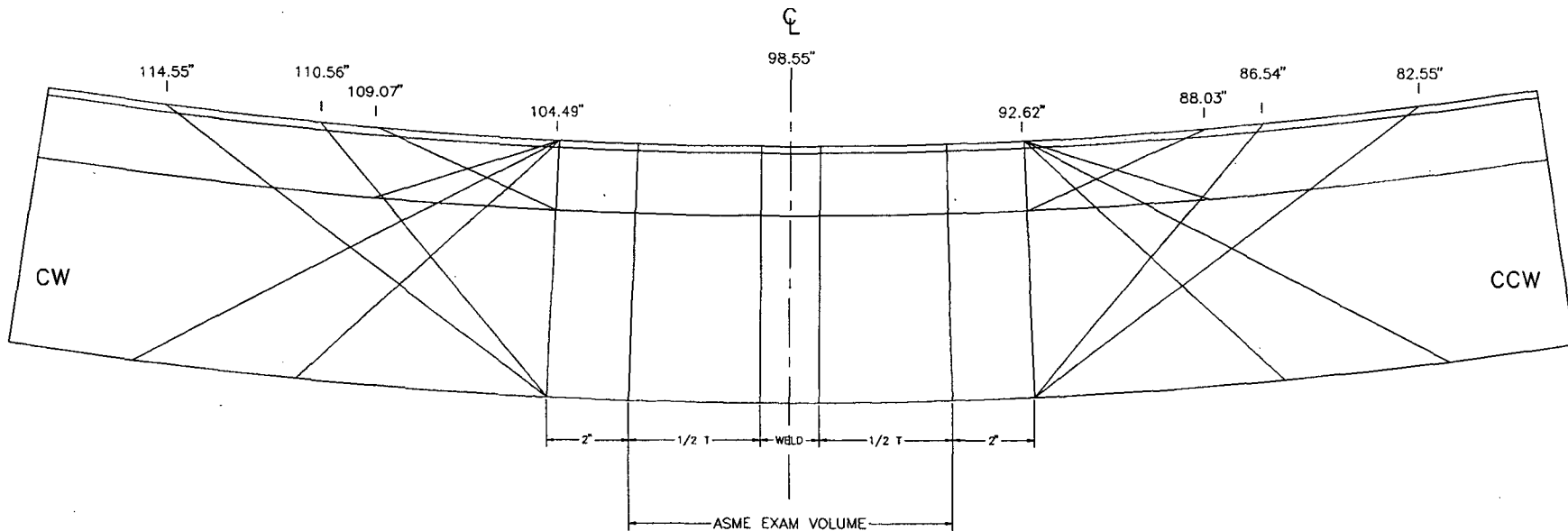

Nominal Clad T = 3/16"
 Nominal Base Metal T = 6 3/8"
 1 Degree = 2.19"

CH.	ANGLE	DIR.	MIN X	MAX X
1	0 W	0	92.62	104.49
2	0 W	90	92.62	104.49
3	70 UP	0	92.62	104.49
4	70 CW	90	88.03	104.49
5	70 DN	180	92.62	104.49
6	70 CCW	270	92.62	109.07
7	45 UP	0	92.62	104.49
8	45 CW	90	86.54	104.49
9	45 DN	180	92.62	104.49
10	45 CCW	270	92.62	110.56
11	60 UP	0	92.62	104.49
12	60 CW	90	82.55	104.49
13	60 DN	180	92.62	104.49
14	60 CCW	270	92.62	114.55
15	0 BM	0	92.62	114.55
16	0 BM	90	82.55	104.49

00000 0000

00041 41 OF 43 R1160

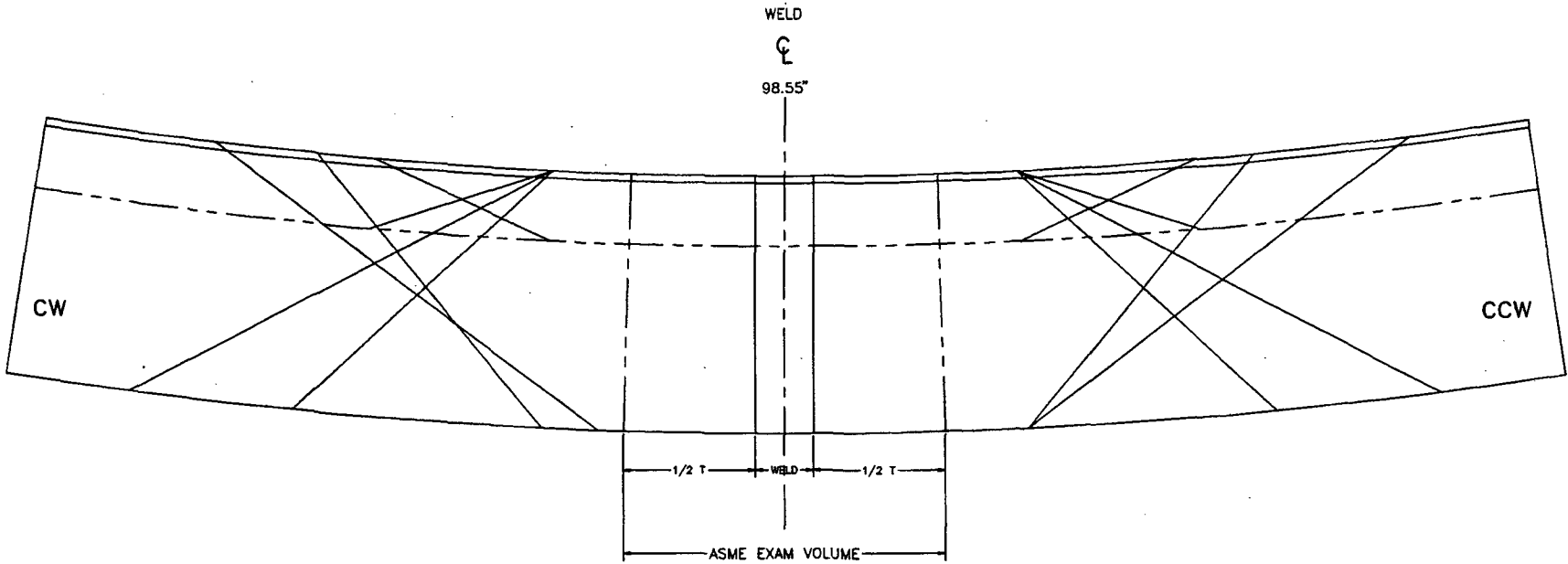

Nominal Clad T = 3/16"
 Nominal Base Metal T = 6 3/8"
 1 Degree = 2.19"

P-scans limited due to Jet Pump Brackets.
 Reference Scanner Data Setup BF-087 and BF-089

00000 01888

00042
 121160
 42 of 43

GE NUCLEAR ENERGY	BROWNS FERRY UNIT 3	JET PP AUTOMATED SCAN LIMIT	SCALE: NONE	DWG. V2ABCJET	REV. 0
-------------------	---------------------	-----------------------------	-------------	---------------	--------

00000 0437

00043 43 OF 43
K1160

WELD
⊕
98.55"

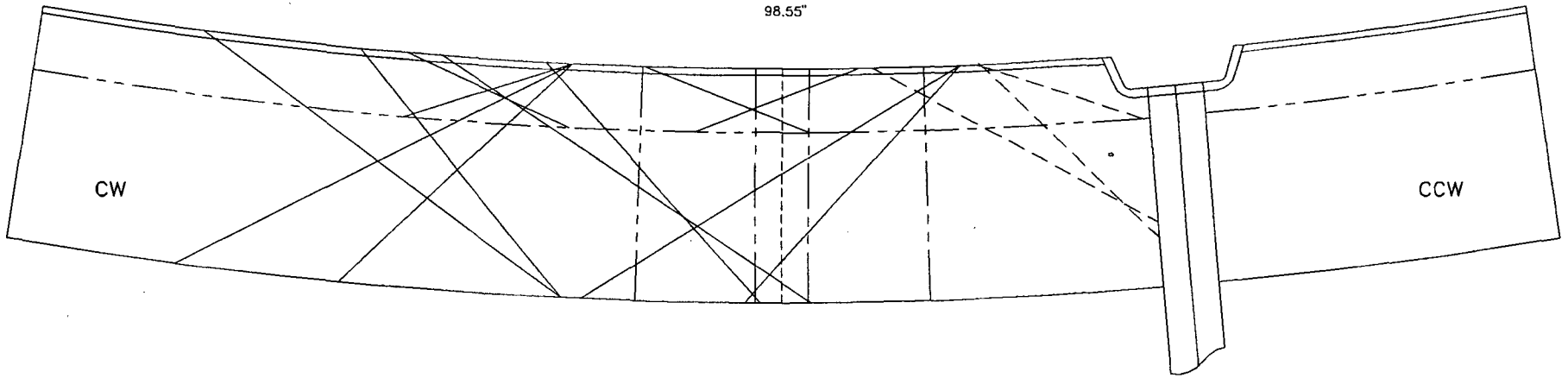

Nominal Clad T = 3/16"
Nominal Base Metal T = 6 3/8"
1 Degree = 2.19"

----- EXTENDED SCAN AREA

GE NUCLEAR ENERGY	BROWNS FERRY UNIT 3	N16A NOZ. AUTOMATED SCAN LIMIT	SCALE: NONE	DWG. V-2AN16A	REV. 0
-------------------	---------------------	--------------------------------	-------------	---------------	--------