

US-APWR

**Verification and Validation
Implementation Plan**

Non-Proprietary Version

February 2012

**©2010-2012 Mitsubishi Heavy Industries, Ltd.
All Rights Reserved.**

Revision History

Revision	Date	Page (Section)	Description
0	April 2010	All	Original issued
1	February 2012	General	Revised capitalization of section titles. Revised the numbers of references “Reference 1, 2, 3, ...” to “Reference 5-1, 5-2, 5-3, ...”. Revised “ref” to “Reference”. Revised document number of reference.
		p.v (Abstract)	Added the paragraph for RAI Response No.796 (Question No. 18-152). Deleted “etc.” for RAI Response No.796 (Question No. 18-155).
		p.2 (Section 2.0)	Added the paragraph for RAI Response No.796 (Question No. 18-152). Deleted “etc.” for RAI Response No.796 (Question No. 18-155). Added the paragraph to end of this section for RAI Response No. 755 (Question No. 18-117).
		p.3 (Section 2.1)	Added description to second paragraph for RAI Response No. 796 (Question No. 18-153).
		p.5 (Section 4.1)	Deleted “etc.” for RAI Response No.796 (Question No. 18-155). Added two sentences as second paragraph for RAI Response No. 664 (Question No. 18-88).
		p.6 (Section 4.2.2)	Added description for RAI Response No. 796 (Question No. 18-171).
		pp.7-8 (Section 4.3.1)	Deleted “etc.” for RAI Response No.796 (Question No. 18-155).

Revision	Date	Page (Section)	Description
			Added description to twelfth bullet pertaining to CCF for RAI Response No. 677 (Question No.07-08-10).
		p.8 (Section 4.3.2)	Deleted "1999" for RAI Response No. 796 (Question No. 18-156).
			Added description about Appendix 1.
		p.8 (Section 4.3.3)	Revised description about minimum number of crew, from "10 crews" to "5 crews".
		pp.9-13 (Section 4.3.4)	Deleted "etc." for RAI Response No.796 (Question No. 18-155).
			Revised description for RAI Response No. 796 (Question No. 18-155,157).
			Deleted sentence for RAI Response No. 796 (Question No. 18-158).
			Added description for RAI Response No. 796 (Question No. 18-159).
		pp.13-15 (Section 4.3.5)	Added description for RAI Response No. 796 (Question No. 18-162).
			Added description about measures of situation awareness.
			Revised "mental" to "cognitive".
			Added description about measures of workload.
			Revised description about objective measures of operator performance.
		p.17 (Section 4.4)	Added description for RAI Response No. 796 (Question No. 18-161).
		p.18 (Section 4.4.2)	Added description.
		p.20 (Section 4.4.5)	Deleted "etc." for RAI Response No.796 (Question No. 18-155).
		pp.21-25 (Section 4.5)	Deleted "etc." for RAI Response No.796 (Question No. 18-155).

Revision	Date	Page (Section)	Description
			<p>Added description for RAI Response No. 796 (Question No. 18-174).</p> <p>Added description for RAI Response No. 796 (Question No. 18-162).</p> <p>Revised description about analysis of pass/fail indicators.</p> <p>Revised description for RAI Response No. 796 (Question No. 18-170).</p> <p>Added description for RAI Response No. 796 (Question No. 18-172).</p> <p>Added description about Appendix 1.</p>
		pp.25-26 (Section 4.6)	<p>Revised section title for RAI Response No. 796 (Question No. 18-175).</p> <p>Added description for RAI Response No. 796 (Question No. 18-171).</p> <p>Added description for RAI Response No. 796 (Question No. 18-175).</p>
		p.26 (Section 4.7)	<p>Added description for RAI Response No. 796 (Question No. 18-173).</p>
		p.27 (Section 5.0)	<p>Revised description of references.</p> <p>Revised title and number of reference 5-6 for RAI Response No. 796 (Question No. 18-156).</p>
		pp.28-36 (Appendix 1)	<p>Added appendix 1 for RAI Response No. 796 (Question No. 18-151, 155, 159, 163, 164, 165, 167, 168,).</p>

© 2010-2012
MITSUBISHI HEAVY INDUSTRIES, LTD.
All Rights Reserved.

This document has been prepared by Mitsubishi Heavy Industries, Ltd. ("MHI") in connection with the US Nuclear Regulatory Commission ("NRC") licensing review of MHI's US-APWR nuclear power plant design. No right to disclose, use or copy any of the information in this document, other than by the NRC and its contractors in support of the licensing review of the US-APWR, is authorized without the express written permission of MHI.

This document contains technology information and intellectual property related to the US-APWR and it is delivered to the NRC on the express condition that it not be disclosed, copied or reproduced in whole or in part, or used for the benefit of anyone other than MHI without the express written permission of MHI, except as set forth in the previous paragraph.

This document is protected by the laws of Japan, US copyright law, international treaties and conventions, and the applicable laws of any country where it is being used.

Mitsubishi Heavy Industries, Ltd.
16-5, Konan 2-chome, Minato-ku
Tokyo 108-8215 Japan

Abstract

This document presents the implementation plan for the US-APWR human factors verification and validation tests and analysis (V&V). The US-APWR verification and validation implementation plan complies with 10 CFR 50.54 and follows the methodology as applied to the design testing program conducted under the Mitsubishi Heavy Industry's Phase 1a and Phase 1b program see reports MUAP-DC018, MUAP-07007, MUAP-08014 and MUAP-09019 (Reference 5-1, 5-2, 5-3 and 5-4). The V&V program utilizes the output from the task analysis, human reliability analysis, HRA, and operational experience review, OER as well as the procedure development effort.

The V&V described in this Implementation Plan will utilize the US-APWR generic design that is the bases of the US-APWR design certification.

The V&V is conducted under an implementation procedure utilizing U.S. licensed and trained plant personnel for subject crews and independent, qualified and trained test personnel for test management and post-test data analysis. The Verification will utilize an NRC approved HSI Design Style Guide (Reference 5-5) early in the V&V process so as to allow for, as needed, interface modifications. A set of selected test scenarios with objective and subjective acceptance criteria will be applied in part task, mock up and/ or a full scope dynamic simulator as appropriate. These scenarios will be selected to include a robust set of operating conditions that will include all risk significant human actions identified in the HRA and the findings from the OER study. The Validation program will specifically use the full scope dynamic simulator developed for operator training and in compliance with ANS/ANSI 3.5 (Reference 5-6) requirements, for all in main control room (MCR) activities. All validation tests will rely on a robust set of US-APWR operating procedures and will include the incorporation of non MCR personnel to simulate real world conditions. Simulation of supportive activities outside of the MCR, (such as local control stations, the TSC, emergency operations facility) may use mock up and part task approaches. To simulate real world conditions as they impact the performance of the operators, personnel engaged in activities such as maintenance, instrument calibration, will be part of the validation of the HSI of the main control room. As in the previous design tests, noted above, subjective data will be collected through test personnel and subject crew questionnaires and interviews, and real time video and audio recording. Objective plant data will automatically be collected via the simulator computer for each scenario. A converging perspectives analysis approach will be applied to the data analysis and conclusions regarding the HSI interface performance, including use of the existing HED data process.

Table of Contents

List of Figures.....	vii
List of Acronyms.....	viii
1.0 Purpose.....	1
2.0 Scope	2
2.1 Background	2
3.0 Applicable Codes, Standards and Regulatory Guidance	4
4.0 Implementation Plan	5
4.1 Operational Conditions Sampling	5
4.2 Design Verification.....	5
4.3 Integrated System Validation.....	7
4.4 Test Design	17
4.5 Data Analysis.....	20
4.6 Conclusions	25
4.7 V & V HED Resolutions	26
5.0 References.....	27
Appendix 1 Examples of Scenarios of Design Certification Validation Phase 2b Scenario Event Sequence Descriptions and Acceptance Criteria.....	28

List of Figures

Figure 2.1-1	HFE Overall Work Flow	3
--------------	-----------------------	---

List of Acronyms

AOO	Anticipated Operational Occurrences
ARP	Alarm Response Procedure
ATWS	Anticipated Transient Without Scram
BHEP	Basic Human Error Probability
BISI	Bypassed or Inoperable Status Indication
CCF	Common Cause Failure
CCW	Component Cooling Water
C/C	Control Center
COL	Combined License
CBP	Computer-based Operating Procedure
COTS	Commercial-Off-The-Shelf
CPU	Central Processing Unit
CV	Containment Vessel
D3	Defense-in-Depth and Diversity
DAC	Design Acceptance Criteria
DAS	Diverse Actuation System
DBA	Design Basis Accident
DC	Design Certification
DCD	Design Control Document
DF	Dependency Factor
DHP	Diverse HSI Panel
DMC	Date Management Console
DTM	Design Team Manager
ECCS	Emergency Core Cooling System
EF	Error Factor
EFC	Error-Forcing Contexts
EFW	Emergency Feed Water
ELM	Engineering Line Manager
EOF	Emergency Operations Facility
EP	Back Feed Electric Power
EPM	Engineering Project Manager
ESF	Engineered Safety Feature
ESFAS	Engineered Safety Feature Actuation System
FMEA	Failure Modes and Effects Analyses
FC	Fail to Close
FC	First Concrete
FO	Fail to Open
F.O.	First Out
FTA	Fault Tree Analysis
GOMS	Goals, Operators, Methods, and Selection rules

GUI	Graphical User Interfaces
HA	Human Action
HAZOP	Hazards and Operability Analysis
HDSR	Historical Data Storage and Retrieval
H.E	Human Error
HED	Human Engineering Descriptions
HEP	Human Error Probability
HEPA	High-Efficiency Particulate Air
HFE	Human Factors Engineering
HFEVMTM	HFE V&V Team Manager
HRA	Human Reliability Analysis
HSI	Human System Interface
HSIS	Human System Interface System
HVAC	Heating, Ventilation, and Air Conditioning
I&C	Instrumentation and Control
ITAAC	Inspections, Tests, Analyses, and Acceptance Criteria
ITV	Industrial Television
LBB	Leak Before Break
LBLOCA	Large Break Loss Of Coolant Accident
LC	Locked to Close
LCO	Limiting Condition for Operation
LDP	Large Display Panel
LER	Licensee Event Report
LERF	Large Early Release Frequency
LO	Locked to Open
LOCA	Loss Of Coolant Accident
MCB	Main Control Board
MCR	Main Control Room
M/C	Metal Clad Geer
MELCO	Mitsubishi Electric Corporation
MELTAC	Mitsubishi Electric Total Advanced Controller
MHI	Mitsubishi Heavy Industries
MSLB	Main Steam Line Break
NIS	Nuclear Instrumentation System
NPP	Nuclear Power Plant
OER	Operation Experience Review
OSD	Operational Sequence Diagram
PAM	Post Accident Monitor
PCMS	Plant Control and Monitoring System
PM	Project Manager
PRA	Probabilistic Risk Assessment
PRC	Process Recording Computer
PSF	Performance Shaping Factor
PSMS	Protection and Safety Monitoring System

QA	Quality Assurance
RCS	Reactor Coolant System
R.G.	Regulatory Guide
RHR	Residual Heat Removal
RMS	Radiation Monitoring System
RO	Reactor Operator
RPS	Reactor Protection System
RSC	Remote Shutdown Console
RSR	Remote Shutdown Room
RSS	Remote Shutdown Station
RT	Reactor Trip
RTB	Reactor Trip Breaker
RWSP	Refueling Water Storage Pit
SAR	Safety Analysis Report
SAT	Systematic Approach to Training
SDCV	Spatially Dedicated Continuously Visible
SER	Safety Evaluation Report
SFP	Spent Fuel Pit
SG	Steam Generator
SGTR	Steam Generator Tube Rupture
SLS	Safety Logic System
SBO	Station Black Out
SPDS	Safety Parameter Display System
SRO	Senior Reactor Operator
SS	Shift Supervisor
STA	Shift Technical Advisor
Tcold	Reactor Coolant Inlet Temperature
T/C	Thermocouple
Thot	Reactor Coolant Outlet Temperature
THERP	Technique for Human Error Rate Prediction method
TMI	Three Mile Island
TR	Topical Report
TSC	Technical Support Center
UMC	Unit Management Computer
UPS	Uninterruptible Power Supply
UV	Under Voltage
V&V	Verification and Validation
VDU	Visual Display Unit
VTM	V&V Team Manager

1.0 Purpose

This document describes the Verification and Validations implementation plan for the US-APWR.

The Mitsubishi Heavy Industry (MHI) Verification and Validation, V&V, program will provide logical and comprehensive evidence that the integrated human system interface system, HSI, of the US-APWR conforms to good human factors principals and that it adequately supports plant personnel in the safe and efficient operations of the plant. The V&V program will assure that the integrated design remains within acceptable performance limits under a broad set of operating modes and conditions.

2.0 Scope

The MHI V&V Implementation Plan is intended to meet the review criteria as outlined in NUREG 0711 (Reference 5-7). The overall V&V program makes use of the other HFE elements in the design process as shown in the Overall Work Flow, figure 2.1-1.

The V&V described in this Implementation Plan will utilize the US-APWR generic design that is the bases of the US-APWR design certification.

The US-APWR V&V implementation program will verify that the HSI provides all the alarms, information and controls needed to support the personnel tasks as identified in the Task Analysis and that the HSI characteristics and environment meet the HSI Design Style Guide (Reference 5-5). The V&V implementation program will also validate the integrated system through performance based tests applying, as additional guidance, NUREG/CR 6393 (Reference 5-8), to the full range of plant operating modes including the following:

- Startup/ Shutdown,
- Normal Operations,
- Abnormal and Emergency operations,
- Transient conditions.
- Risk Significant human actions and selected beyond design events

The implementation plan addresses the MCR and selected remote locations, (such as local control stations, TSC, Emergency Operations Facility) that can influence the main control room crew's performance. HSIs outside of the MCR will also be evaluated through this V&V implementation plan through the application of the same tool set with the exception of not utilizing dynamic simulation since the simulator is unique to the main control room. The V&V program will include personnel beyond the standard MCR crew of STA, SRO, and RO. This will exercise the integrated system (including HSI, personnel, procedures) for situations in which communications and coordination with personnel outside of the control room, e.g. maintenance, is required and when additional personnel are performing work in the control room. The goal of the V&V program is to test the HSI in real world conditions resulting in confidence that all possible situations have been enveloped by the V&V and therefore there is reason to believe that the integrated HSI of the US-APWR meets safety and performance objectives.

All HSI that is in the scope of the US-APWR HFE program, as described in subsection 18.1.1.2, is within the scope of the V&V program. The V&V for the MCR will utilize full scope dynamic simulation, including lighting conditions and simulation of the noise environment. The V&V for HSI outside the MCR will utilize mockup and part task simulation methods. The same V&V methods, such as operational conditions sampling, design verification, test design and data analysis, as applied to the MCR, will be adapted to thoroughly evaluate the HSI in all facilities. The process of capturing and resolving HEDs will be applied to all HSI

2.1 Background

MHI has already incorporated into its HSI design process, a set of HSI tests and assessments which included verification of a sample of the HSI to the NUREG 0700 standards (Reference 5-9), and as recommended by ISO 11064 (Reference 5-10), scenario driven dynamic, human

in the loop, MCR simulator validation style tests. The methodology and results of this effort are referenced throughout this V&V implementation plan and are reported in MUAP-08014 and MUAP-09019 (Reference 5-3 and 5-4).

The purpose of the tests reported in References 3 and 4 was to establish input conditions to the US-APWR generic HSI design and to support the development of the methodology that is described here in, MUAP-10012, for application in the final Verification and Validation as per NUREG-0711. References 3 and 4 are, therefore, not taken credit for as any part of the final NUREG-0711 V&V, but instead are a bases for the HSI design and this Implementation Plan and as such are viewed as supplemental information. It is the intent of MHI to apply these earlier reported, and reviewed by NRC staff, methods to the US-APWR V&V implementation through this plan and subsequent V&V procedures. In addition MHI has submitted a document to the NRC containing a NUREG 0711 (Reference 5-7) Compliance Road Map that further explained, section 11, its testing methodology and its relationship to the application of NUREG-0711 (Reference 5-7) to the V&V program. As practical, the V&V plan will continue to utilize licensed operators from operating US plants throughout the implementation of the V&V plan. Their role will, however, be governed by the duties at their plants and schedule restrictions. Only licensed operators will be used during the validation part of this plan where licensed operators would be required in plant operations.

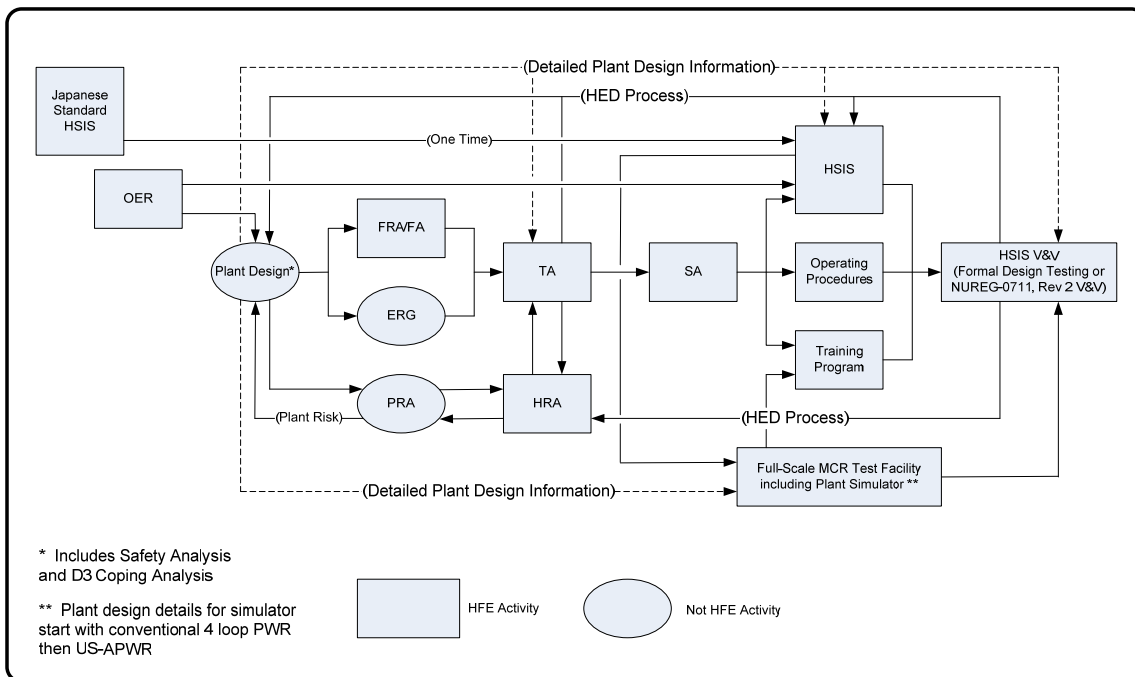

Figure 2.1-1 HFE Overall Work Flow, Reference MUAP-09019 R0, part 1

3.0 Applicable Codes, Standards and Regulatory Guidance

Applicable codes and standards are referenced in MUAP-DC018, and MUAP-07007.

4.0 Implementation Plan

4.1 Operational Conditions Sampling

MHI carefully selects the combination of HSI features, plant process equipment degradations and failures, number and qualifications of operating staff members, the operational procedures, i.e., the test scenario variables, which are to be employed, exercised and stressed with each Integrated HSI System validation test scenario. What follows is a description of the process that MHI follows, as part of executing their V&V Plan, to select those test scenario variables for each Integrated System validation test scenario. Additional discussion can be found in MUAP-07007 and MUAP-08014 (Reference 5-2 and 5-3).

Integrated HSI V&V will encompass all RI HAs to ensure the HSI design supports human performance to the minimum extent defined in the HRA/PRA. The V&V will include, as per NUREG-0711, the interface, procedures, staffing and qualifications as well as training assumptions of the design.

MHI's V&V Team includes a person, or persons, who are an expert in designing Integrated Human-System Interface validation tests, i.e., a person qualified in designing tests that assess human performance. This person prepares a set of test goals and objectives for each validation test that is used as the starting point by the scenario developers in developing each scenario. These test goals and objectives are expressed in human performance terms, e.g., focus of attention, directability, observability and situation awareness. An example of a test goal is "Stress the 'observability' provided / supported by the HSI by masking one process event with another", or "Stress the support for situation awareness provided by the HSI by causing the operators' attention to be focused in one place while initiating a fault in another place".

In addition, this Integrated HSI Validation Test designer assures that a maximum range of 'situational factors that are known to challenge human performance', e.g., workload, error forcing contexts and fatigue are addressed / asked for in the set of test goals and objectives that are used in the validation test scenario development.

The scenario developers are responsible for assuring that a satisfactory set of plant conditions and 'personnel tasks', e.g., procedure guided tasks, knowledge based tasks, all risk-significant human actions, OER supported human interactions, degraded HSI, are covered in the set of scenarios that comprise the Integrated HSI Validation testing.

As noted above, this scenario development process is augmented with additional personnel when the focus of the validation testing is on HSIs other than the MCR. This person or persons brings an understanding of the scope of plant operations that is the defined responsibility of the HSI in question, e.g., TSC, RSS, and can determine which human performance issues are to be supported by the HSI in question, and, therefore, tested, e.g., the TSC is not capable of any direct plant equipment control actions, it is only able to monitor plant process performance. As a result, those human performance issues that are related to 'directability' or taking control actions are not relevant to the TSC HSI.

4.2 Design Verification

The design verification for the main control room HSI will be completed at least 6 months prior to beginning the integrated system validation. This schedule is such as to give adequate time to the design team to make HSI design changes resulting from HEDs that have been identified

from the verification prior to initiation of validation efforts. Verification of the HSI of remote, non main control room, locations do not require the dynamic simulator and will be completed on an as practical schedule based on design completeness.

4.2.1 HSI Inventory and Characterization

The US-APWR HSI inventory and characterization is based on the US Basic HSI system as derived from the completed Phase 1 V&V testing program. As the final US-APWR HSI design is completed the inventory will be entered into the MHI quality assurance configuration control program, including a complete description of its characteristics. Any changes to the US Basic HSI will undergo independent evaluation to gain confidence that past HEDs will not reoccur during future V&V activities. As appropriate, additional redesign or analysis will be performed by the Design Team based on recommendations from the evaluation process. This evaluation may include revisiting the functional analysis, task analysis and HRA to assure that design changes do not have any adverse impact on earlier analysis conclusions. The final product of the US-APWR HSI inventory will be integrated with the output of this iterative Basic HSI design process. The completely integrated HSI System will be fully tested under this V&V Implementation Plan and its subsequent procedures. Additional descriptions can be MUAP-08014 and MUAP-09019 (Reference 5-3 and 5-4).

4.2.2 Task Support Verification

A multidisciplinary V&V team composed of at least 3 members having the combined expertise of HFE, plant operations and task analysis, and independent from the design team, will be formed. This team will, applying the approved verification procedure, conduct a detailed assessment of the personnel tasks identified by the task analysis as compared to the available alarms, displays and information sources, and control capabilities provided by the HSI. The Task Support verification will also include an assessment of the Computer Based Procedure system design (e.g. display contents, navigation links) and the procedures completeness in supporting the tasks. A standard paper and pencil walk through method will be used in this assessment. This will include the use of the PC tool for RO, SRO and STA VDU display design contents when it is determined by any one member of the team that the HSI design does not adequately supply the needed interface, an HED will be written and entered into the HED data base for resolution. Similarly, the team determines that part of the interface is unnecessary, i.e. unnecessary or confusing alarms, an HED will be written and entered into the HED data base for resolution. As with all HEDs, resolution will follow the process described in MUAP-09019 (Reference 5-4) part 1.

The Team will base its assessment on;

- The most recently completed task analysis and, as appropriate,
- Detailed descriptions of the HSI design,
- Use of a Static Portable PC Based Analysis tool containing display screens and simplified navigation capabilities, as described and applied in MUAP-08014, part 1 section 2 and
- The dynamic training simulator.

If only one team member has performed the verification assessment, then a sampling process will be adopted for a second analyst to verify the assessment and its results. In addition to the HEDs generated by the verification, a report documenting the assessment will be written.

4.2.3 Design Verification

A team, similar to that described in section 4.2.2 above will be assembled. This team can be, but does not have to be, composed of the same individuals as the task support verification team. The assessment process will follow the HED driven process as described 4.2.2 above, and will be performed under an approved implementation procedure. The design verification will apply the methodology that is described in MUAP-08014 (Reference 5-3) part 1 sect 2. However, 100% of the HSI will be included to assure a consistent application across the entire HSI of the design principals. In order to have an efficient process the HSI may be segmented in a logical manor allowing the team members to conduct the assessment both in series and in parallel. Should situations arise where part of the HSI has only been reviewed by one team member, a sampling process will be adopted to check the individual outcomes.

The design verification will use the most recent US Basic HSI Design Style Guide (Reference 5-5) and both the Static Portable PC Based Analysis tool and the dynamic training simulator as the working representation of the US-APWR HSI design.

In addition to the HEDs generated by the verification a report documenting the assessment, will be written and available for audit.

4.3 Integrated System Validation

4.3.1 Test Objectives

The minimum test objectives are presented below. The final set of validation objectives will be documented in the V&V implementation procedure that will govern the validation tests.

The minimum test objectives are;

- Validate the role of plant personnel,
- Validate the minimum shift levels, and shift turnover,
- Validate maximum shift levels for any area where the V&V team suspects potential human performance challenges,
- Validate that personnel tasks can be successfully performed in the required time within performance limits, under normal and degraded HSI system conditions,
- Validate that the HSI contains adequate alarms, information, control and feedback during all modes of plant operation and conditions,
- Validate that the HSI supports all identified risk significant human actions,
- Validate that the HSI supports human error reduction and recovery activities,
- Validate the crews situation awareness and workload, including secondary tasks,
- Validate the efficiency of the interface management system and the crews ability to navigate between the HSI and procedures,
- Validate that the crew can tolerate failures of individual HSI features (e.g. loss of alarms, loss of LDP, loss of CBP),
- Validate continued operation, accident management and safe shutdown with complete loss of all non-safety HSI,

- Validate accident management and safe shutdown with common cause failure of digital systems, demonstrating that there is adequate time margin between the time required for credited operator actions and the time available, as defined in MUAP-07014.
- Validate adequate crew communications and coordination within and outside of the MCR,
- Validate that the crew can effectively transition between the computer based procedures and paper procedures,
- Validate that there are no elements of the HSI that can negatively affect performance, such as unneeded or confusing alarms,
- Validate operating crew support of plant maintenance and test activities.

4.3.2 Test Beds

The principal validation test bed will consist on a dynamic plant simulator which has been verified in a manner that is consistent with ANS/ANSI 3.5 (Reference 5-6). Test data collection process will follow that was reported in MUAP-08014 and MUAP-09019 (Reference 5-3 and 5-4). A reasonable attempt will be made to also accurately simulate the expected MCR environment. In cases where this is not reasonable, additional testing will be confirmed in the plants MCR through the Design Implementation Plan.

In addition to the dynamic simulator, mock ups and part task simulation will be used for non MCR activities that are needed to support the testing scenarios. A set of three detailed test scenarios are included in this implementation plan as Appendix 1. This appendix is intended to illustrate by example, the application of this Implementation Plan in its entirety and is expected to be applied as a future reference and guidance to assure a consistent and tractable level for scenario selection and development, test measures and observables, acceptance criteria, and results data analysis. For simplicity of this Plan, this statement is not repeated in each section.

4.3.3 Plant Personnel

Plant personnel will be selected from a pool of experienced plant staff and, for positions requiring it licensed operators, that reasonably represent the existing US plant crew population. As in past design testing, this pool of personnel is expected to be derived from current or potential licensees of the US-APWR. The selection process will be based on the requirement to have an unbiased representative sample of plant personnel that will be interfacing with the HSI and a statistically significant number of crews for each scenario. This will include at least 3 crews for each scenario and a minimum number of 5 crews. To accomplish this, a modified random sampling process will be employed that assures the plant personnel statistically represent the population of operating crews expected to be employed at a US nuclear power plant. This process will include the dimensions of:

- Random unbiased selection from a pool of operators,
- Industry age distribution,
- Industry agenda distribution,
- Industry education level distribution,
- Industry experience distribution, and

- As practical account for regional differences.

As a rule, personnel that have supported the V&V test development and the pilot test will not take part as plant personnel test participants.

4.3.4 Scenario Definition

The Phase 2 V&V scenarios will meet the Operational Conditions Sampling (OCS), criteria of NUREG-0711 section 11.4.1.2.1, 11.4.1.2.2 and 11.4.3.2.4. Individual sampling dimensions will be combined through expert judgment by the Scenario Developers, of the MHI V&V Team, as part of their responsibilities as described in section 4.1, above. Resulting scenarios will combine into realistic events, multiple characteristics identified from the OCS process. The Scenario Developers will assure that the scenarios are not biased by representing only positive outcomes, easy to conduct, or well structure and practiced. Scenarios will stress the crew through both normal and challenging events containing multiple and unanticipated failures. As guidance, the Scenario Developers will use References 3, 4 and 6. The process and resulting scenarios will be documented by the Scenario Developers and be independently reviewed before application in the V&V program.

The Phase 2 V&V scenarios selection dimensions will meet the criteria of NUREG-0711 section 11.4.1.2.1 and will include considerations of:

- Scenarios of full range of plant operating modes, including startup, shut down, significant power changes, refueling and normal operations
- Scenarios of abnormal and emergency operations, transient conditions, and low-power and shutdown conditions which includes credited operator's action in the DCD Chapter 15. Description of the scenario and any pertinent "prior history" necessary for personnel to understand the state of the plant upon scenario start-up
- Specific initial conditions (precise definition provided for plant functions, processes,
- Systems, component conditions and performance parameters, e.g., similar to plant shift-turnover)
- Events (e.g., failures) to occur and their initiating conditions, e.g., time, parameter values, or events
- Precise definition of workplace factors, such as environmental conditions
- Task support needs (e.g., procedures and technical specifications)
- Staffing objectives
- communication requirements with remote personnel (e.g., load dispatcher via telephone)
- HAs that have been found to affect plant risk by means of PRA importance and sensitivity analyses should also be considered risk-important.
- Internal and external initiating events and actions affecting the PRA Level I and II analyses of Chapter 19. This will include all risk important human actions determined from the HRA.
- HAs identified by the OER.

- Failure of digitalized I&C systems with above scenarios
- HAs with computer based systems, such as alarms and CBP system
- HAs in monitoring automated systems and in assuming control when automation fails
- Failure of all non-safety HSI system
- Operation from the remote shutdown console to safe shutdown
- System interconnections as they relate to failures
- Full range of procedure, knowledge based, cognitive and tasks including personnel interactions within and external to the control room
- Situations that stress navigational requirements
- Full range of situational factors such as operational difficult tasks, error forcing events, high physical and mental workload, and environmental as applicable for the specific location of the operation.
- As well as factors and HEDs that were found to be significant during the Phase 1a/1b V&V testing program.

Qualifications of Personnel Performing Scenario Development:

The focus of the integrated validation test is on the MCR HSI, then, therefore MHI utilizes personnel that have experience in human-system interface design (i.e., are familiar with the HSI design and good HSI design practices) and human factors (i.e., are familiar with human error initiators and causes) in conjunction with personnel that are experienced reactor operator instructors or are SRO qualified operators of pressurized water reactors (i.e., are familiar with the practical operation of the HSI in the context of monitoring and controlling a PWR). It is worth noting that these three areas of expertise may not require three separate individuals. Usually, MHI employs a minimum of two experienced people, that jointly work through the development of the Operational Conditions Sampling strategy and then assemble the scenarios from the results, but these two people always are qualified to cover the three areas of expertise described above.

For validation of a remote location, e.g., the Technical Support Center (TSC), the Remote Shutdown Station (RSS), the Emergency Operations Facility, Local Panels. MHI uses experts that are familiar with the operation of the remote location in question. This will be done regardless of whether the focus of the validation test is to be the interaction with the MCR, i.e., focused primarily on the MCR staff's understanding and response to the remote locations needs, or whether the focus is to be on the HSI design of the remote location's interface. These experts are expected to specifically understand the tasks and task needs of personnel that are working in the remote location in question.

Finally, upon completion of the scenario definitions / descriptions, the descriptions, acceptance criteria, the test plan, are reviewed by the panel of experts that comprise the MHI HSI multi-disciplinary design team.

Scenario Definition:

The development of integrated HSI validation test scenarios, i.e., completing the 'definition' of a scenario, is a creative multidimensional process that is more dependent upon the experience and intuition of the developers and the stated goals and objectives of the test that employs the scenario that is under development than upon following a rote procedure. Consider, for

example, a validation test that has a goal of testing the effectiveness of the MCR personnel's performance in initiating and effectively following through with the activities involved in that portion of the plant's Site Emergency Plan for which they are responsible. This involves their ability to determine that such action is necessary, informing appropriate site personnel of the necessity of such action in a timely manner, calling for opening and manning the Technical Support Center, potential lengthy and complex communication between personnel in the MCR and those in the TSC to satisfactorily prevent or minimize any hazard to the public in bringing the plant to a 'safe shutdown' condition. In addition, validation test designers would like this test to assess the workload imposed on the MCR staff in using the alarm feature of the HSI (e.g., are there too many unnecessary alarms, can the root cause of an alarm be quickly determined by the MCR staff, is the root cause of the initiating process disturbance salient, are Critical Safety Function violations salient, do such alarms attract and properly focus MCR staff attention.).

Such a list of test goals is approached by MHI scenario developers by first selecting an underlying plant process event that, in this case, is severe enough to demand the initiation of the Site Emergency Plan, and then to superimpose on top of the temporal trajectory of such an event, additional component or system degradations and failures that are expected to elicit specific MCR control board responses that will activate the desired HSI features, and stress staff responses and actions, accordingly.

The scenario developers use a variety of plant process events and contexts as the underlying context upon which a scenario is built, again, depending upon the goals of the test. Among these are major design basis and beyond-design basis accidents, as employed above; or major normal plant evolutions, such as power reduction or increase; major component start-up or shutdown, e.g., reactor coolant pump, turbine-generator heat-up and synchronization, and evolutions and scenarios that are included in current operating plant Reactor Operator Re-Qualification Exams.

In the course of assembling the underlying 'major' event or plant evolution that is to be involved in the scenario and adding additional events and situations to it, the developers also accumulate the relevant information that will be employed as the equivalent of the 'shift turnover briefing' that will 'set the current operational stage' for the incoming MCR crew / test subjects.

The scenario definition for each scenario included in the V&V will include:

- (1) The operational conditions selected for inclusion in the validation tests should be developed in detail so they can be performed on a simulator. The following information should be defined to provide reasonable assurance that important performance dimensions are addressed and to allow scenarios to be accurately and consistently presented for repeated trials:
 - description of the scenario and any pertinent "prior history" necessary for personnel to understand the state of the plant upon scenario start-up
 - specific initial conditions (precise definition provided for plant functions, processes, systems, component conditions and performance parameters, e.g., similar to plant shift turnover)
 - events (e.g., failures) to occur and their initiating conditions, e.g., time, parameter values, or events
 - precise definition of workplace factors, such as environmental conditions
 - task support needs (e.g., procedures and technical specifications)
 - staffing objectives
 - communication requirements with remote personnel (e.g., load dispatcher via telephone)

- the precise specification of what, when and how data are to be collected and stored (including videotaping requirements, questionnaire and rating scale administrations)
 - specific criteria for terminating the scenario.
- (2) Scenarios should have appropriate task fidelity so that realistic task performance will be observed in the tests and so that test results can be generalized to actual operation of the real plant.
- (3) When evaluating performance associated with operations remote from the main control room, the effects on crew performance due to potentially harsh environments (i.e., high radiation) should be realistically simulated (i.e., additional time to don protective clothing and access radiological controlled areas).

This has been a general overview of the MHI plan for developing validation test scenarios, and as was used in the tests reported in MUAP-08014 and MUAP-09019. The detailed and annotated scenarios and success, acceptance, criteria as a means of illustrating typical results of this process are shown in Part 3 Appendix 8.3 and 8.4 of technical report MUAP-09019.

Scenario Human Performance Acceptance Criteria Development:

As with the development of the scenario, MHI utilizes operational experts to develop and / or review proposed 'acceptance criteria' for the scenario as a whole and, when appropriate, for various degrees of human performance and plant equipment operation. These operational experts have backgrounds as reactor operator instructors, systems engineers, plant and I&C designers. In particular, input from reactor operator instructors that are involved in current plant operator re-qualification examinations is solicited. Also human factors and / or human-system interface design experts are included as needed.

In addition, consideration is given to good practices and acceptance criteria that are stated in current industry standards and guidelines, e.g., those from the Institute of Nuclear Power Operation (INPO) and from the operator license examinations and guidance of the U.S. NRC.

Clearly, the types of acceptance criteria that are developed for a given scenario are dependent upon the goals and objectives of the validation test, as well as on the details of the event(s) that the test subjects / operators are being asked to deal with during the scenario. Depending upon these factors, the types of acceptance criteria that are developed by this group of experts include:

- Global plant process parameter criteria, e.g., process parameters maintained below safety system actuation, or within design limits,
- Where appropriate, timeliness of operator actions, e.g., time required prior to the depressurization of the Reactor Coolant System during a Steam Generator Tube Rupture, time required to determine the need for and execute a risk-important human action. Time can also take on the dimension of 'number of touches' in the navigation between displays to access desired data, alarms or control, in particular, controller face-plates,
- Operator performance with respect to teamwork, communications, execution of procedures (e.g., thoroughness of annotations of procedures, check-off of steps and sign-off of completion of defined blocks of steps), though highly subjective, are evaluated against current industry standards of good practices,
- Risk-based criteria derived from the PRA, the associated fault trees, and cited risk-significant human actions,
- In some instances, depending upon a test goal's identified need to assure operator awareness of some plant or process circumstance, e.g., awareness of the activation of

a Critical Safety Function, an operator's understanding of the current plant state or the state of a particular component or variable may be acquired and compared against the actual state or value.

- Contains the lessons learned from the OER,
- Stresses the secondary tasks associated with a digital control room such as screen navigation, the drill down process and transition between HSI features

Acceptance Criteria related to human performance are defined and included in the description of each scenario. In the case of overall plant performance measures, the acceptance criteria are shown, along with a graph of the process parameter of interest (e.g., Steam Generator level), as part of the analysis results of the test. Included in the Appendices of this plan are four examples of stated test goals, the scenarios that are typical results of MHI's process for scenario development, and where appropriate, examples of human performance acceptance criteria annotated within the scenario descriptions.

4.3.5 Performance Measures

Multiple converging measures of performance are used to identify human error discrepancies (HEDs) that have the potential to negatively impact operator individual and team performance.

The integrated validation will include two explicitly defined types of performance measures:

1. *Performance Measures used as 'Pass/Fail' Indicators:* These are a subset of performance measures that are explicitly designated as 'pass/fail' that are used for decisions as to whether the design is validated or not. Failed indicators must be resolved before the design can be validated. Pass/Fail indicators will include plant conditions, component and system operations, specific operator actions or inactions, as identified prior to each scenario as critical to safety.
2. *Other Performance Measures:* These are additional performance measures that enable more detailed understanding of the impact of the HSI on individual operator and crew performance. They are used to identify HEDs that will then be evaluated using the HED evaluation process (see the discussion in Reference 5-4, Part 1).

Specifically, the Performance Measures include collecting:

- (a) *Objective measures*, designed to be pass / fail, with direct links to plant behavior (e.g., terminating a SGTR leak before SG level in the ruptured SG reaches some threshold level) based on data capture of plant process data and operator actions on the HSI;
- (b) *Objective measures* of crew performance during the validation scenario exercises that include video and audio recordings of operator performance;
- (c) *Objective measures* of operator performance including responses to situation awareness probes (both verbal probes and non-intrusive measures);
- (d) *Subjective assessments* of individual and team performance are made by an interdisciplinary team of expert observers that includes human factors and plant operations experts;
- (e) *Subjective assessments* of the HSI and its impact on performance, including self-ratings of workload, situation awareness, and teamwork, are provided by the experienced NPP operators who participate in the study. Operator questionnaire feedback on the HSI will be collected via post-scenario and final questionnaires. This includes both Likert rating-scale questions and open-ended questions soliciting HEDs,

and;

- (f) Specific HEDs are documented on individual HED documentation forms and are entered into a formal HED tracking database. All individuals involved in the V&V, including test administrators, test observers and test participants are encouraged to document any HEDs they identify by filling out an HED form.

Measures of Situation Awareness:

Situation awareness is a complex, multi-dimensional construct (Reference 5-12 and 5-13). MHI intends to establish that the US-APWR HSI effectively supports operator situation awareness by utilizing multiple different measures, including both objective measures and subjective operator self-assessment measures of situation awareness that produce converging results.

Objective measures of situation awareness will be obtained using two methods:

- (1) *Non-intrusive human performance measures.* Specific events will be inserted into the simulator scenarios (e.g., equipment malfunctions, systems placed in manual that should be in automatic) to determine whether operators are able to detect resulting plant symptoms and identify the source of the problem. This provides an objective indication of operator situation awareness. Data will be collected by reviewing simulator logs of operator actions to evaluate if these events were noticed. Observers will also be keyed to evaluate if the crew acknowledged the events during primary activities. This measurement technique has the advantage that it can be collected while the scenario is dynamically running without interfering with the natural ongoing cognitive and collaborative operator crew processes.
- (2) *Verbal probes.* While operators are engaged in scenario task performance, simulated phone calls will come in at predefined points in the scenario. The simulated call will be from higher-level plant management personnel asking for a status update. The operators are asked to respond to a single spoken question to assess their current situation awareness. They will be asked to provide a brief oral response summarizing current plant status (including any ongoing plant disturbances and/or equipment malfunctions they are aware of), and how they are currently addressing those problems. This enables an objective assessment of operator situation awareness, without requiring the simulation to be interrupted.
- (3) *Intrusive probes.* In selected cases the scenario will be paused and the crew questioned about their individual or collective assessment of imbedded events. This will only be applied when it has been determined that the pause will not negate the fidelity of the scenario.

In addition, subjective operator self-assessment of situation awareness will be obtained via Likert-rating scale questions that are included in questionnaires that operators are asked to fill out following each simulator scenario as well as after the completion of all test scenarios. This provides a complementary measure of situation awareness that taps operator confidence that the HSI is providing adequate information to support situation awareness. Likert-rating scale questions have been successfully used to measure operator self-assessment of the effectiveness of support of an HSI on different aspects of situation awareness in a number of previous studies (Reference 5-14 and 5-15).

Measures of Workload

After each Integrated HSI V & V test scenario, Plant Operations Personnel / operators are asked to fill out an assessment of their own cognitive and physical workload with respect to the effort required for this scenario as compared to what would be required for equivalent scenarios at their home plant. The workload questions are included as part of a short post-scenario questionnaire that includes Likert rating scale questions eliciting operators' subjective self assessment of mental workload, physical workload, situation awareness and teamwork. Observers also complete a similar set of questions to rate each scenario and crew on cognitive workload. Examples of post-scenario questionnaire forms are provided in MUAP-08014 (Reference 5-3). In addition simulator logs may be reviewed to establish operator time based actions during period of high activity and this compared to pre established success criteria.

These multiple sources of data are analyzed and the results are used to provide *converging indications* of human factors issues of primary concern, as well as to identify specific 'HEDs' that are entered into an HED database. If multiple measures or indications point to the same problem, it reinforces the need to address it. If none of the measures reveal a problem, it increases confidence that there is not a problem.

In addition the qualitative information gleaned from observation of crew performance during the scenarios and verbal debriefs that are conducted at the conclusion of the scenarios provide important background information for interpreting specific HEDs that operators document on the HED forms. This facilitates later analyses by the HED expert review team that requires interpreting, connecting, and generalizing across often cryptically written individual HEDs.

(a & b) Objective measures of crew performance - Objective Performance Analysis

The 'objective' data collected during each test scenario is analyzed by operational experts to assess the impacts of operator actions on the plant's processes and equipment states. Applied in the analyses are acceptance criteria for operator actions and for overall plant process behavior, developed for each scenario, that help to identify sources of potential human error that need to be addressed in the HSI design.

The results of these analyses form one of the 'perspectives' or performance measures of the tests, which is converged with the others in the final conclusions from the tests in the Integrated Results from the Verification and Validation Tests Final Report.

(c) Objective measures of operator performance – Situation Awareness

Results from explicit verbal probes are captured by the expert observers. Non-intrusive measures of situation awareness, such as inserted inquiries from I&C technicians or maintenance by telephone calls or walk ins, are reflected in the operator actions and verbalizations during the scenario, i.e., video, audio and computer capture of control actions. As appropriate simulator logs are also reviewed to evaluate if operators observed and took action specific events.

(d) Subjective assessments of individual and team performance – Expert Observer Assessment of Operator Performance

Each scenario is observed by a plant operations expert and a minimum of one HFE experts. The observers document their individual assessments of crew performance on a post-scenario observer form that is filled out during and immediately after the scenario, for an example of this and other forms that will be used MUAP-09019 (Reference 5-4) part 1 appendices A and B.

The first portion of the form asks the expert observer to document performance problems that they observed during the scenario. The form explicitly asked observers to document the following 9 categories of performance problems:

- Monitoring/detection problems;
- Errors of omission;
- Critical action delays;
- Errors of commission;
- Procedure deviations;
- Teamwork problems;
- Situation awareness problems;
- Workload problems and
- Other problems.

Observers indicate whether they observed problems in each of these performance problem categories and describe the nature of the problem, if any, that arise. These form entries amount to ‘measures’ of inadequate performance as judged by the expert observers.

A consensus process is used to merge the inputs of the different observers into a single consensus summary description of the performance of each crew on each scenario.

The next section of the post-scenario observer form asks the observers to rate technical and teamwork performance on a 5-point Likert rating-scale.

The Post-Scenario Observer Form also asks expert observers whether they felt that the crew size was sufficient for that scenario.

The final portion of the post-scenario observer form includes blank spaces for observers to write down HEDs they identified.

(e) Subjective assessments of the HSI – Operator Questionnaire Data A and Operator Comments during the Debriefs

There are two questionnaire forms that operators fill out:

- (1) A post-scenario operator form that is filled out at the end of each scenario, and
- (2) A final operator feedback form that is filled out at the end of the non-safety HSI scenarios.

The operator questionnaire forms consist of two types of items:

- (1) Rating questions that use a five point Likert–scale; and
- (2) Questions that solicit HEDs in free-form text.

(f) HEDs generated during the scenario

- (1) HEDs and the HED process, including the data base, assessment and resolution is covered elsewhere in this implementation plan.

Converging the Perspectives

The multiple types of objective and subjective data that are collected and analyzed provide converging evidence with respect to the adequacy of the HSI design (i.e., validation). The operator performance data provides objective indication of instances of human performance problems. The Likert-scale rating questions on the operator post-scenario and final operator feedback form provide numeric scores provide objective evidence of the design adequacy. The HED input forms and open-ended HED entries in the operator feedback forms provide indication of specific HEDs that need to be addressed. The verbal debrief sessions provide rich contextual information that can be used to interpret any HEDs that may have been initiated, understand their extent, and how they are linked to human performance difficulties that the operator crews experienced. In most cases multiple measures are expected to point to the same conclusion with respect to the HSI design adequacy. In cases where none of the measures reveal a problem the fact that multiple measures were used to probe for a problem, increases confidence that there is no problem.

4.4 Test Design

Recent human factors research makes clear that changes in control room technology can impact operator monitoring and situation awareness, teamwork and technical performance. As a consequence, multiple converging methods are used to probe the impact of the US-APWR HSI on individual and team performance. This includes measures that are intended to assess the impact of the US-APWR HSI on the ability of individuals and teams to maintain situation awareness of plant state; to take control action in pace with plant dynamics, and to maintain supervisory control of automated systems. Data is also collected on the ability of the US-APWR HSI to support teamwork, including the ability to communicate and coordinate activities, and the ability of the supervisor to maintain awareness of, and supervise the actions of the reactor operator (RO). The impact of the US-APWR HSI on mental and physical workload is also examined. Special emphasis is placed on the ability of the US-APWR HSI to support two-person operation – an RO responsible for controlling the plant and a supervisor – this is the design basis of the US-APWR plant design.

When designing the V&V tests consideration will be given to anthropometric and physiological factors that may affect performance. The test facility will simulate and the scenario definitions will specify expected plant conditions such as layout and work station dimensions, background noise, lighting, display characterization. The control room will include miscellaneous equipment that may add clutter. In areas outside of the control room special environmental stressors such as temperature and radiation will also be included in the tests. (Note that while the focus of this validation test design description is on validating the MCR HSI, this same general approach is planned to be used to perform the validation testing of other US-APWR interfaces, particularly the Technical Support Center (TSC), the Remote Shutdown Station (RSS), Local Panels and Test and Maintenance Panels.)

4.4.1 Coupling Crews and Scenarios

In general, the MHI US-APWR validation test design will be, as in the past, of the 'repeated-measures' type, i.e., MHI will make every effort to test every crew with each scenario used in the test. However, in case that may not always be the best practice or practical, MHI will have personnel that are experienced in human factors test design review the assignment of crews to test scenarios and assure that important characteristics of the scenarios are 'balanced' or distributed as evenly as possible across multiple crews. All scenarios will be tested with multiple crews. For all risk significant and or time critical scenarios a minimum of five crews will be tested. This being the expected number of crews for an US-APWR single unit. If there are

inconsistent results for scenarios that do not make use of all crews, then additional crews will be added to the scenario test to gain a statistically justified conclusion.

In the case of concerns with respect to scenario sequencing and the possibility of a training bias developing, again, based on past testing experience MHI will have the scenario sequences used in the US-APWR validation testing reviewed by an experienced human factors test designer and human factors engineer to assure that such bias is minimized, if not eliminated. All crews all undergo the same training program and it will be generalized to assure learning objectives for the V&V are met, they will be test scenario neutral and scenario sequences will not follow a "give away" sequencing. Scenarios will also contain reasonable normal operation time to assure crews are not pre tuned to immediate events and actions at each onset of a scenario.

4.4.2 Test Procedures

Basic Procedure Conditions and Limitations

Prior to each series of validation tests, a detailed test procedure is prepared that includes:

- order and description of the scenarios, including estimated time of execute execution, along with any directions for the Simulator System Engineer with respect to the manner and timing of execution of the scenario,
- assumed pre-scenario existing plant process conditions, i.e., a pre-scenario brief to the crew,
- scenarios and related information
- measures and observations
- secondary failures to be inserted
- normal plant activities used to confound the scenario
- time for test subject scenario debriefs and breaks,
- time allotted for final test-series debrief

In addition, test observers will have been trained, reference section 4.4.3, and will have agreed to policies on how to interact with test subjects when unexpected behavior or unplanned events in the test scenario occur.

The HSI Validation facility is the US-APWR HSI system. The simulator plant model is validated to the latest US-APWR design. If significant design changes are made after the completion of the HSI system V&V, and it is determined, through analysis, that the changes may have a negative impact the conclusions of the V&V, additional testing may be performed. This however is done on a case by case basis.

Test subjects shall be advised that discussion of operational details of scenarios and their sequences with other US-APWR Plant Operations Personnel (i.e., test subjects) is to be avoided.

US-APWR Plant Operations Personnel returning to their normal plant duties shall be cautioned to refrain from discussing operational details of the test scenarios and their sequences with future Plant Operations Personnel, i.e., possible future test subjects.

Discussion regarding the US-APWR HSI features shall also be avoided. This helps to distinguish HEDs that may be limited to individual operator opinions vs. HEDs that reflect a

broader spectrum of operator opinions, and therefore are likely to indicate more serious design flaws. Regardless, all HEDs will be evaluated.

This set of tests is about locating and describing problems in the US-APWR HSI that need to be improved. Lack of finding problems constitutes validation of the HSI.

Prior to start of the validation testing, all test subjects are assumed to have had sufficient training, reference section 4.4.4. As a result, any difficulties, errors, and problems encountered or exhibited by Plant Operations Personnel may be attributed to deficiencies in the support provided by the HSI or an indication of a problematic V&V training program. In the latter case the training program will be modified and crews retrained as appropriate. It is anticipated that training shortcomings will be for the most part identified and fixed during the Pilot test, reference section 4.4.5.

With the permission of the operating crews, video and audio recording are active during the execution of the scenarios. Video recording enhances the evaluation of the validation results.

Plant Operations Personnel shall be informed that they are expected to 'verbalize all actions' during the execution of the scenarios in the manner they are currently trained for operations at their plant.

With Plant Operations Personnel's permission, video and audio recording are performed during observational interviews.

4.4.3 Test Personnel Training

A minimum of three experts in the areas of HFE, plant operations, and operator training shall serve as test observers on any given test series – two HFE observers and one plant operations expert.

Training of test observers involves several activities. First, one month prior to the start of the validation testing, a five-day training and coordination meeting is held to review the test procedure, practice using the data collection instruments, walk through all the scenarios, and if needed participate in one day formal training on the HSI. All test personnel will also be involved in the pilot testing prior to the start of the validation. This provides an opportunity for the test observers to gain a shared understanding of the purpose of the data collection instruments, and how they are to be used. Second, all expert observers should be in attendance during the first week of the validation. This enables all of the observers to gain a shared understanding of the test procedure, how the observer forms are to be filled out, and how the debriefs are to be conducted. Third, the expert observers in attendance shall meet jointly at the end of each week to review their observations made during the week, and fill out a consensus expert observation form. This serves to further calibrate the observers and insures a shared understanding and interpretation of observations. Finally, since the validation sessions are videotaped, any HFE expert who is not in attendance, has the opportunity to review the debrief sessions so as to remain aware of issues that arose during weeks they were not in attendance and to insure continuity in the manner in which the debriefs are conducted.

Prior to the beginning of the testing period, the HFE Test Observers are given a minimum of 1 hr. of re-training by human factors and operational experts familiar with the origin of the data collection forms with regard to the data collection forms, their usage, and the test scenarios.

The Simulator System Engineer is responsible for the operation of the US-APWR plant simulator. The training that the Simulator System Engineer receives is familiarization with the

plant process event sequences within each scenario and the order in which the scenarios are to be executed.

4.4.4 Participant/ Crew Training

Each test participant will be selected randomly from a pool and will have completed an accredited operator license (at either the RO or SRO license level) training program and hold or have held the appropriate US license for the position in the scenario. Additionally the participants will have completed an extensive hands on familiarization program via the US-APWR dynamic V&V simulator, and in addition, a one month formal training program, taught by training experts that include classroom and simulator training. The training goal will be to have the participants at a level of proficiency that approximates licensing on the US-APWR plant. Participants will be trained on numerous plant events that encompass the knowledge needed to perform the validation scenarios, but will not be trained on the specific validation scenarios nor will participants be made up of the crew that supported the pilot testing, see section below.

4.4.5 Pilot Testing

Pilot testing is conducted to validate the accuracy of the simulator, test the test design and procedure, gain experience for the test personnel in running the test and assure that the validation runs smoothly and correctly measures the integrated HSI performance. MHI has used this general approach, test design, scenario definition, data collection, in performing design tests prior to the validation tests of the US-APWR and will continue to do so for any future HSI testing that it finds is necessary. In the course of conducting these non-HSI validation tests, MHI has made effort to improve the test process with each test cycle. In addition, the US-APWR validation tests will utilize personnel that are experienced human factors test designers to assure that test bias, from any source, is minimized, if not eliminated. A final pilot test, validation dry run, will be performed applying the validation procedure, scenarios, success criteria, and data collect methods as planned for the actual validation prior to the actual validation.

4.5 Data Analysis

As in the earlier design testing referenced throughout this plan, MUAP-08014 and MUAP-09019 (Reference 5-3 and 5-4), MHI will use a converging perspectives method of data analysis.

The integrated validation will include two explicitly defined types of performance measures:

- *Performance Measures used as 'Pass/Fail' Indicators:* These are a subset of performance measures that are explicitly designated as 'pass/fail' that are used for decisions as to whether the design is validated or not. Failed indicators must be resolved before the design can be validated;
- *Other Performance Measures:* These are additional performance measures that enable more detailed understanding of the impact of the HSI on individual operator and crew performance. They are used to identify HEDs that will then be evaluated using the HED evaluation process.

The multiple types of objective and subjective data that will be collected and analyzed provide

converging evidence that the HSI meets plant safety goals, or identifies areas of the US-APWR HSI that need to be improved. The operator performance data and success criteria provide objective indication of instances of human performance success or problems. The Likert-scale rating questions on the operator post-scenario and final operator feedback forms as well as the test personnel forms provide numeric scores that could be used to objectively identify aspects of the US-APWR HSI that operators perceive are positive and aid the success of the crew, or deficient and may lead to human performance difficulties. The HED input forms and open-ended HED entries in the operator feedback forms provide indication of specific HEDs that need to be addressed. The verbal debrief sessions provide rich contextual information that can be used to identify successful performance, as well as interpret the HEDs, understand their extent, and how they are linked to human performance difficulties that the operator crews experienced. Finally, the video and audio records offer a historical temporal link between the plant data (i.e. plant parameters, component positions, alarms, displays) and the crew actions for each scenario. In most cases multiple measures are expected to point to the same problem, reinforcing the need to address the issue. In cases where none of the measures reveal a problem the fact that multiple measures were used to probe for a problem, increases confidence that there is no problem. The extent, relationship across the HSI indicative of a broader issue, of an HED and the interrelationships between HEDs are addressed at three levels. First, the test participants are asked explicitly in both the questionnaires and structured verbal debriefing if they believe the HED is representative of a larger or underlying problem. Second, at the end of each day of testing, the test observers are instructed to review each HED and reach consensus on each HED's relationship to other HEDs and the possible extent of the HED and third, the expert panel reviews each HED during one of their regular scheduled meetings. Part of their review explores this issue. Each of these reviews is documented.

The results are entered into a spreadsheet and frequency counts are computed indicating how many crews (out of the total number included in the test) exhibited (one or more) performance problems in each of the 9 performance problem categories.

Acceptance Criterion: Categories where three or more crews exhibited a problem are highlighted as requiring particular attention.

Such categories point to human performance areas of potential concern and indicate a need to examine the extent to which HEDs may have contributed to this human performance problem. Using the converging measures logic, HEDs that may have contributed to the human performance difficulties are identified based on review of validation team observations made during the scenarios as well as operator feedback obtained during the post-scenario debriefs and final debrief sessions, and HEDs that are submitted by the operators.

The next section of the post-scenario observer form asks the observers to rate technical and teamwork performance on a 5-point Likert-rating scale.

Acceptance Criterion: A score of 3 is labeled "acceptable", a score of 1 is labeled "very poor" and a score of 5 is labeled "very good".

Mean scores for each scenario across crews is computed separately for the plant operations expert and the HFE expert(s) since they represented different types of expertise. Mean scores are also computed across all the observers for each scenario. The results are typically presented in a table. Mean scores across observers of less than 3 are typically highlighted to flag performance problems. Such scores point to human performance areas of potential concern and indicate a need to examine the extent to which HEDs may have contributed to this human performance problem.

The Post-Scenario Observer Form also asks expert observers whether they felt that the crew

size was sufficient for that scenario. The expert observers again generate a consensus response. A table is created that shows how many crews the observers indicated that the crew size was not sufficient for that scenario.

Acceptance Criterion: Instances where they judge crew size to be insufficient for three or more of the tested crews for a given scenario are highlighted in the table.

The final portion of the post-scenario observer form includes blank spaces for observers to write down HEDs they identified. Each validation team member reviews their own forms across the weeks they participate in crew observations and enters their HEDs into the HED tracking database.

The two questionnaire forms that operators fill out can be found in MUAP-08014 (Reference 5-3) Appendix A:

- (1) A post-scenario operator form that is filled out at the end of each scenario, and
- (2) A final operator feedback form that is filled out at the end of the non-safety HSI scenarios.

The operator questionnaire forms consist of two types of items:

- (1) Rating questions that use a five point Likert-scale; and
- (2) Questions that solicit HEDs in free-form text.

Responses to the Likert-scale rating questions are entered into a spreadsheet from which simple descriptive statistics are computed (number of responders, mean score, range, and frequency of responses with a score of 2 or less).

Acceptance Criterion: Since a “3” or above on the 5-point Likert-scale is labeled ‘acceptable’, any questions that receive a mean rating score of less than 3 are flagged for further examination.

The HEDs that operators enter in the questionnaires are entered verbatim into the HED tracking database. In some cases an operator may enter the same HED onto an HED Input Form as well as on a post-scenario operator form or final operator feedback form. In those cases a single HED should be entered into the database, and noted in the HED entry that this HED is included on an operator feedback form as well as on an HED Input form.

The verbal debrief sessions are attended by the plant operations expert and one or more of the HFE experts. They also, generally, should be attended by one or more of the customer’s management representatives (whose employees are the operator test subjects), as well as by HSI design personnel and I&C Engineers.

Members of the validation observation team, the operators themselves, as well as others attending the debriefs should enter their HEDs into the HED tracking system based on information that is uncovered during the debrief discussions.

In addition, one of the HFE experts should review the final debrief videotapes and generate notes summarizing the recurring themes that arise across crews. These notes are used as a basis for entering higher-level summary HEDs into the HED database. They are also used as a basis for identifying links between human performance issues that are observed in the scenarios, the operator responses to the Likert-scale rating questions and specific HEDs that the operators document.

This enables the validation team to group individual HEDs into higher order classes that reflect common themes as well as to link HED classes to the human performance problems that they contribute to. The results of this analysis are presented in the results section of the Integrated

Results from the Verification and Validation Tests Final Report. They also form the framework that is used to analyze HEDs during the HED Expert Review Panel.

It should be noted that most of the members of the HED Expert Review Panel should attend the crew debrief sessions. This provides the panel members with the background knowledge needed to understand the HEDs identified by the operators and the impact that the operators feel these HEDs had on their individual and team performance.

The data analysis and interpretation process will combine quantitative and qualitative methods to evaluate performance on these performance measures, identify and resolve HEDs, and establish that the HSI design has been validated.

Analysis of Pass/Fail Indicators

Performance measures designated to be pass/fail indicators will be objective measures with direct links to plant behavior (e.g., terminating a SGTR leak before SG level in the ruptured SG reaches some threshold level).

An objective pass/fail criterion will be defined for each Pass/Fail indicator as part of the performance measures development process conducted prior to executing the integrated validation (i.e., these will be defined in the integrated validation procedure.)

Each pass/fail indicator will have acceptance criteria specified at two levels:

1. An acceptance criterion for a given crew in a given scenario (e.g., for a crew to meet the acceptance criterion in a SGTR scenario the crew must terminate the leak prior to the SG level in the ruptured SG reaching value 'X');
2. An acceptance criterion across crews, specified in terms of the proportion of crews tested on a given scenario that must meet this acceptance criterion in order for the design to be considered to have 'passed' on that criterion.

As a general rule, in most cases objective, time dependent histories of specific plant parameters (temperature, pressure, flow rate, radiation level, water level and environmental release), component position or operations (pump on or off, valve open or closed) and operator actions (assuming control of an automated action) will be used as pass fail measures. These values will be downloaded from the simulator and assessed for each scenario.

In addition subjective measures of scenario specific significant factors, i.e., situation awareness that indicate a significant loss of awareness, may, in addition, be used as pass fail performance measures for selected scenarios. This will be at the discretion of the test observers/administrators. It is recognized that under real world conditions crew performance may be more variable than in the integrated validation due to factors such as variability in individual and environmental factors (e.g., level of experience; time of day; fatigue) and increased situational complexity (e.g., additional malfunctions that complicate performance). In order to accommodate for this possibility the 'pass/fail' criteria will be defined conservatively, allowing a margin of error for actual performance to be more variable than performance observed in the integrated validation. For example, the acceptance criterion for a SGTR will require a tighter band of performance than required for safe operation, so as to allow a margin of error for increased performance variability under actual plant conditions.

During the data analysis phase the Pass/Fail indicators will be analyzed using objective quantitative methods. The proportion of crews that meet the acceptance criterion on each pass/fail indicator will be tabulated. If the proportion of crews that meet the acceptance criterion for a given pass/fail indicator meets or exceeds the specified crew proportion threshold, then the design 'passes' that pass/fail indicator.

If the crews that meet the acceptance criterion for a given pass/fail indicator does not reach the crew proportion threshold specified, then the design will be determined to have failed on that criterion. No stoical evaluations are applied to ISV test for pass/fail indicator, which may be useful in the research or development phase (e.g., 90 or 95% of passes are acceptable in the Phase 1a/1b), but the final Basic-US-APWR design should be established in the ISV test. For example if the 'pass/fail' criterion for a SGTR is that the crews must be able to terminate the leak in the ruptured SG prior to the SG level in the ruptured SG reaching a value 'X', and any of the crews meet this criterion, then the design/procedure will be evaluated to have failed on that criterion. The modified design/procedure is to be confirmed to resolve the HEDs in the final ISV test.

For performance measures used as pass/fail indicators, failed indicators must be resolved before the design can be determined to have been validated. The failed 'pass/fail' indicators will be handled through the standard HED evaluation process to identify a resolution. However, these 'failed' indicators will be treated as special cases that require:

- (1) a specific change to address the failed indicator to be identified and implemented (e.g., a change to the HSI, or training, or procedures); and
- (2) the simulator scenarios to be rerun with an equivalent number of crews, to establish definitively that the 'pass/fail' criterion is met once the change has been implemented.

Analysis of Other Performance Measures

Other performance measures, in addition to pass/fail indicators, will be collected and analyzed to identify HEDs. MUAP-09019, part 1 section 6, describes the full HED process. These include:

- Expert Observer assessment of individual operator and team performance (e.g., collected via questionnaire forms);
- Objective measures of operator performance including responses to situation awareness probes (both verbal probes and non-intrusive measures);
- Operator subjective self-ratings (e.g., self-ratings of workload, situation awareness, and teamwork)
- Operator questionnaire feedback on the HSI that will be collected via post-scenario and final questionnaires. This includes both Likert rating-scale questions and open-ended questions soliciting HEDs.

A combination of quantitative and qualitative analyses will be used to analyze and interpret results on these performance measures. This will include:

- Computing descriptive statistics (e.g., means and standard deviations, confidence limits and margin of error) on responses to Likert rating-scale questions;
- Tabulating qualitative comments collected via questionnaires and verbal debriefs, and computing frequency counts;
- Tabulating HEDs and computing frequency counts of how many times the same (or a highly similar) HED was provided across operators, as well as across members of the interdisciplinary validation test observation team.
- Looking for converging patterns of results across measures

Analyses of results across the multiple measures will be used to identify HEDs, as well as to capture the impact of these HEDs on individual and team cognition and performance. A

converging measures logic will be used to identify the HEDs and the human performance concerns that require the most attention. (If multiple measures point to the same problem, it reinforces the need to address it. If none of the measures reveal a problem, it increases confidence that there is not a problem.)

HEDs identified will be entered into the HED tracking database and processed according to the standard MHI HED evaluation, resolution and closure process documented in MUAP-09019 (Reference 5-4).

Appendix 1 of three representative scenarios shows the selection criteria, performance measures, success criteria and scenario description described in section 4.3 to 4.5.

4.6 Conclusions

The conclusions of the integrated system validation will be based on;

- The specific HEDs as well as the extent of the identified performance issue,
- The absolute number of new HEDs identified,
- The performance of the HSI with the human in the loop as compared to the pre test developed success criteria,
- The consensus of the observer's technical opinion, and
- Rigorous statistical data analysis following that discussed in MUAP-08014 and MUAP-09019 (Reference 5-3 and 5-4).

An Independent panel of experts will be used to sample the Validation results and verify the data analysis and the V&V results.

The Verification and Validation results will be documented in a Results Summary Report, in accordance with Reference 5-7 section 11.3. The Results Summary report will include:

- Verification;
 - A description of the application of this Implementation Plan in conducting the Verification program
 - Verification results based on Reference 5-5, examples of results presentation are contained in References 5-3 and 5-4
- Validation;
 - A description of the application of this Implementation Plan in conducting the Validation program
 - A copy of the Validation test procedures
 - A description of the test personnel and plant test crew training program.
 - Qualifications of the test personnel, scenario developers and plant test crew.
 - A description of the test bed
 - A detailed description of all specific scenario sets used in the testing, including plant initial conditions, plant parameters of importance, event timing including expected operator actions, and applicable, scenario specific, performance measures and acceptance criteria
 - Data analysis at the level of depth as reported, as examples, in References 5-3 and 5-4

- Validation results and conclusions as compared to the minimum set of test objectives described in section 4.3.1.
- A copy of the test data collection instruments used in the Validation

4.7 V & V HED Resolutions

As with the previous design test reported in MUAP-08014 and MUAP-09019 (Reference 5-3 and 5-4), HEDs will be generated by the test participants as well as the test personnel and entered into the HED data base as described MUAP-09019 (Reference 5-4) part 1 sections 6 and 7 and will undergo the same evaluation program as described in these two technical reports.

HEDs identified during the Phase 2b V&V will be documented along with their resolution. If it is determined that a specific Phase 2b HED is acceptable, resulting in a decision not to act on its closure, an analysis and justification for the decision will be documented in the results report.

5.0 References

- 5-1 Design Control Document for the US-APWR, Chapter 18, Human Factors Engineering, MUAP-DC018, Revision 3, MHI, March 2011
- 5-2 Human System Description and HFE Process, MUAP-07007, Revision 4, MHI, July 2011.
- 5-3 US-APWR Human System Interface Verification and Validation (Phase 1a), MUAP-08014, Revision 1, MHI, May 2011
- 5-4 US-APWR HSI Design, MUAP-09019, Revision 1, MHI, December 2011
- 5-5 US-APWR HSI Design Style Guide, JEJC-1763-1001, Revision 2, MELCO, May 14 2008
- 5-6 Nuclear Power Plant Simulators for Use in Operator Training and Examination, ANSI/ANS 3.5-1998, Revision 1, April 1998
- 5-7 Human Factors Engineering Program Review Model, NUREG-0711, Revision 2, U.S. Nuclear Regulatory Commission, February 2004
- 5-8 Integrated System Validation: methodology and Review Criteria, NUREG/CR-6393, U.S. Nuclear Regulatory Commission, January 1997
- 5-9 Human-system Interface Design Review Guidelines, NUREG-0700, Revision 2, U.S. Nuclear Regulatory Commission, May 2002
- 5-10 Ergonomics design of Control Centers- Part 1: Principals for Design of Control Centers, ISO-11064, 2000
- 5-11 Chapter 18 of the U.S.NRC Standard Review Plan for the Review of Human Factors Engineering for Nuclear Power Plants, NUREG-0800, Revision 2, U.S. Nuclear Regulatory Commission, March 2007
- 5-12 Situation Awareness Catches on: What? So What? Now What? R.C. Williges (Ed). Reviews of Human factors and Ergonomics, Vol. 2, pp. 89-129 Santa Monica, CA: Human Factors and Ergonomics Society, Y. J. Tenney & R. W. Pew, 2007
- 5-13 Situation Awareness: Review of Mica Endsley's 1995 Articles on Situation Awareness Theory and Measurement, Human Factors, Vol.50, No. 3 pp. 397-403, C. D. Wickens, June 2008
- 5-14 Designing Work-Centered Support for Dynamic Multi-Mission Synchronization, Proceedings of the 2009 International Symposium on Aviation Psychology, E. Roth, R. Scott, R. Whitaker, T. Kazmierczak, R. Truxler, J. Ostwald, and J. Wampler, April 2009
- 5-15 Person-in-the-Loop testing of a Digital Nuclear Power Plant Control Room, in press, Proceedings of the Human Factors and Ergonomics Society, 54th Annual Meeting, Santa Monica, CA: Human Factors Society, E. Roth, J. Easter, R. E. Hall, L. Kabana, K. Mashio, S. Hanada, T. Clouser, G. Remley

**Appendix 1 Examples of Scenarios of Design Certification Validation Phase 2b Scenario
Event Sequence Descriptions and Acceptance Criteria**

