

A



**INDIAN POINT UNIT 2
CONTAINMENT INSERVICE INSPECTION
FIRST PERIOD EXAMINATIONS**



**Category L-A, Concrete Examinations
Tab A - Inspection Drawings**

320785-00

B

C

D

E

F

4

3

2

1

320785-00A

B

C

D

E

F

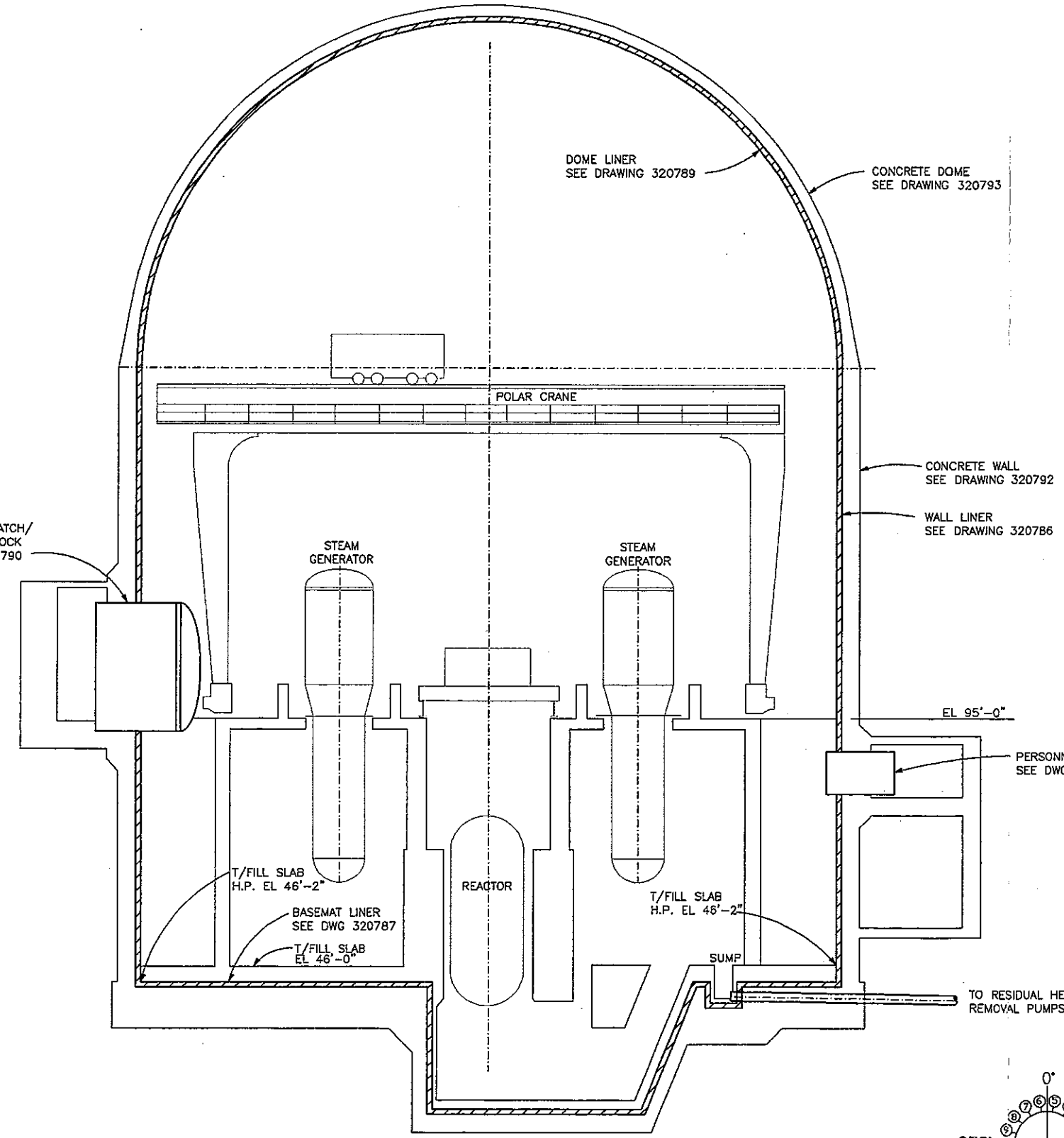

CONTAINMENT ISI GENERAL ARRANGEMENT

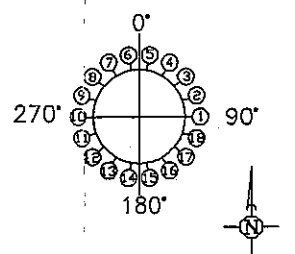

KEY PLAN

COMPUTER GENERATED DRAWING NOT TO BE HAND REVISED

REVISION
USE .1 SIZE TEXT ONLY

REVISION SIGNATURES	
REV	PROJECT ENGINEER
00	

DWG. NO. 320785-00

CON EDISON COMPANY
DWG. TYPE: C
DWG. SIZE: C

LOCATION: INDIAN POINT UNIT 2

TITLE: CONTAINMENT ISI
GENERAL ARRANGEMENT

- APPROVALS -

ENGINEERING MANAGER:

PROJECT ENGINEER:

DESIGNER:

DRAWN BY:

SCALE: NONE DISCIPLINE CODE:

320785-00

320785-00

00-767072A

B

C

D

E

F

REVISION
USE .1 SIZE TEXT ONLY

320792-00

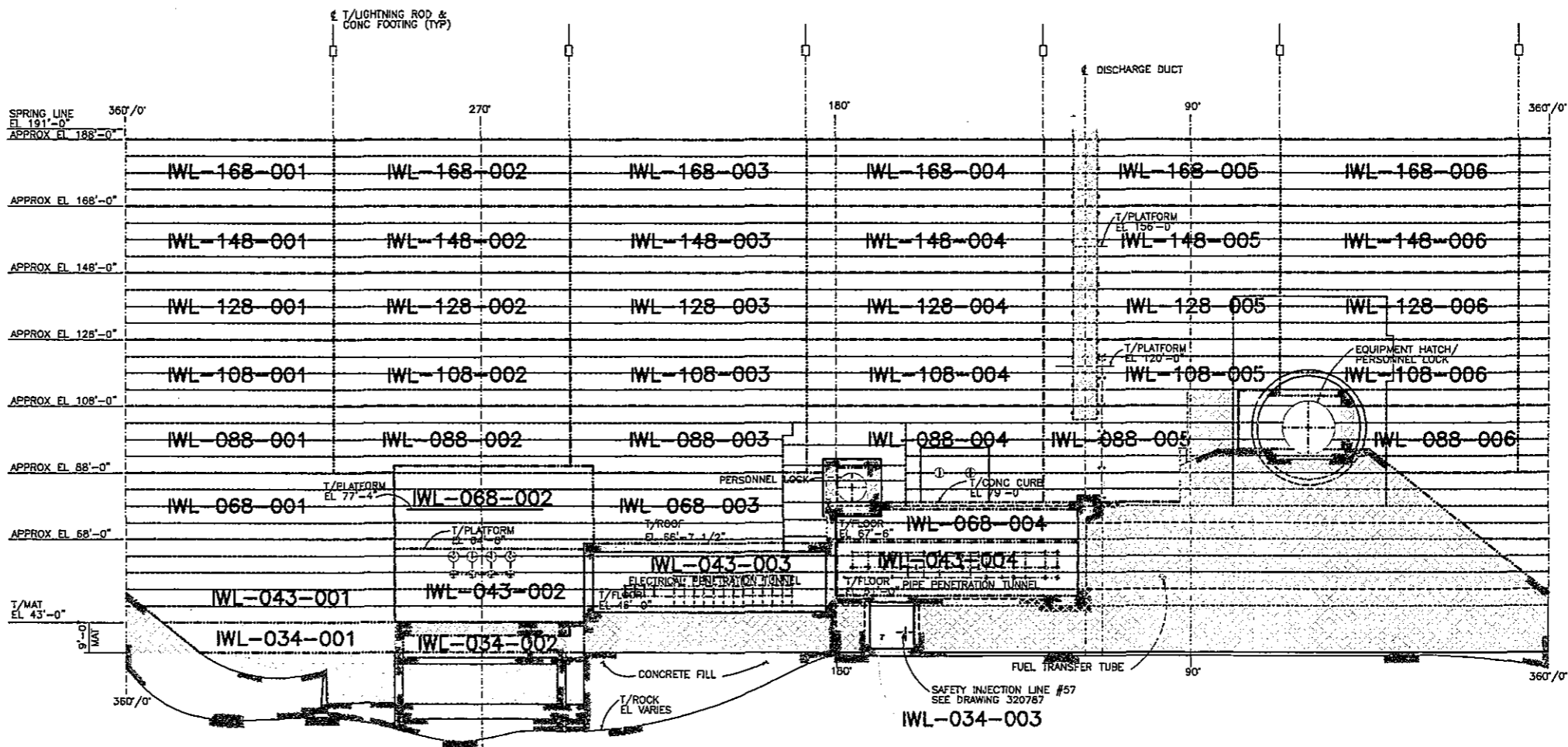

2

CONCRETE ROLLOUT
(EXTERIOR DEVELOPED VIEW, LOOKING FROM OUTSIDE)

- NOTES:
- REFERENCE DEIGN DRAWINGS 9321-F-1024, 9321-F-1121, 9321-F-1130, 9321-F-1156, 9321-F-1196, 9321-F-1206, 9321-F-1210, 9321-F-1211, 9321-F-1212, 9321-F-1226, 9321-F-1261, 9321-F-1291, 9321-F-1319, 9321-F-1326, 9321-F-1343, 9321-F-1344, 9321-F-1360, 9321-F-1385, 9321-F-1485, A205759 & A248449.
 - ZONE BOUNDARIES ARE ESTABLISHED AT LOCATIONS OF CONCRETE POUR CONSTRUCTION JOINTS WHICH ARE SPACED AT APPROXIMATELY 5'-0".

- LEGEND:
- ZONE BOUNDARY
 - CONCRETE SURFACE INACCESSIBLE
 - PENETRATION
 - CONSTRUCTION JOINT
 - EXPOSED CONCRETE FILL AREA
 - IWL-XXX-YYY INSPECTION ZONE NUMBER (SEE DRAWING 320835 FOR INDEX)
 - █ EARTH BACKFILL
 - █ ROCK

320792-00A

B

C

D

E

F

REVISION SIGNATURES

REV PROJECT ENGINEER
00

DWG. NO. 320792-00

CON EDISON COMPANY
DWG. TYPE C
DWG. SIZE C

LOCATION: INDIAN POINT UNIT 2

TITLE: CONTAINMENT ISI
CONCRETE LAYOUT

- APPROVALS -

ENGINEERING MANAGER:

PROJECT ENGINEER:

DESIGNER:

DRAWN BY:

SCALE: DISCIPLINE CODE:

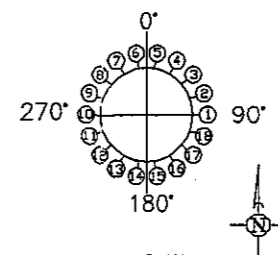

COMPUTER GENERATED DRAWING NOT TO BE HAND REVISED

320792-00

320793-00

B

C

D

E

F

REVISION
USE .1 SIZE TEXT ONLY

320793-00

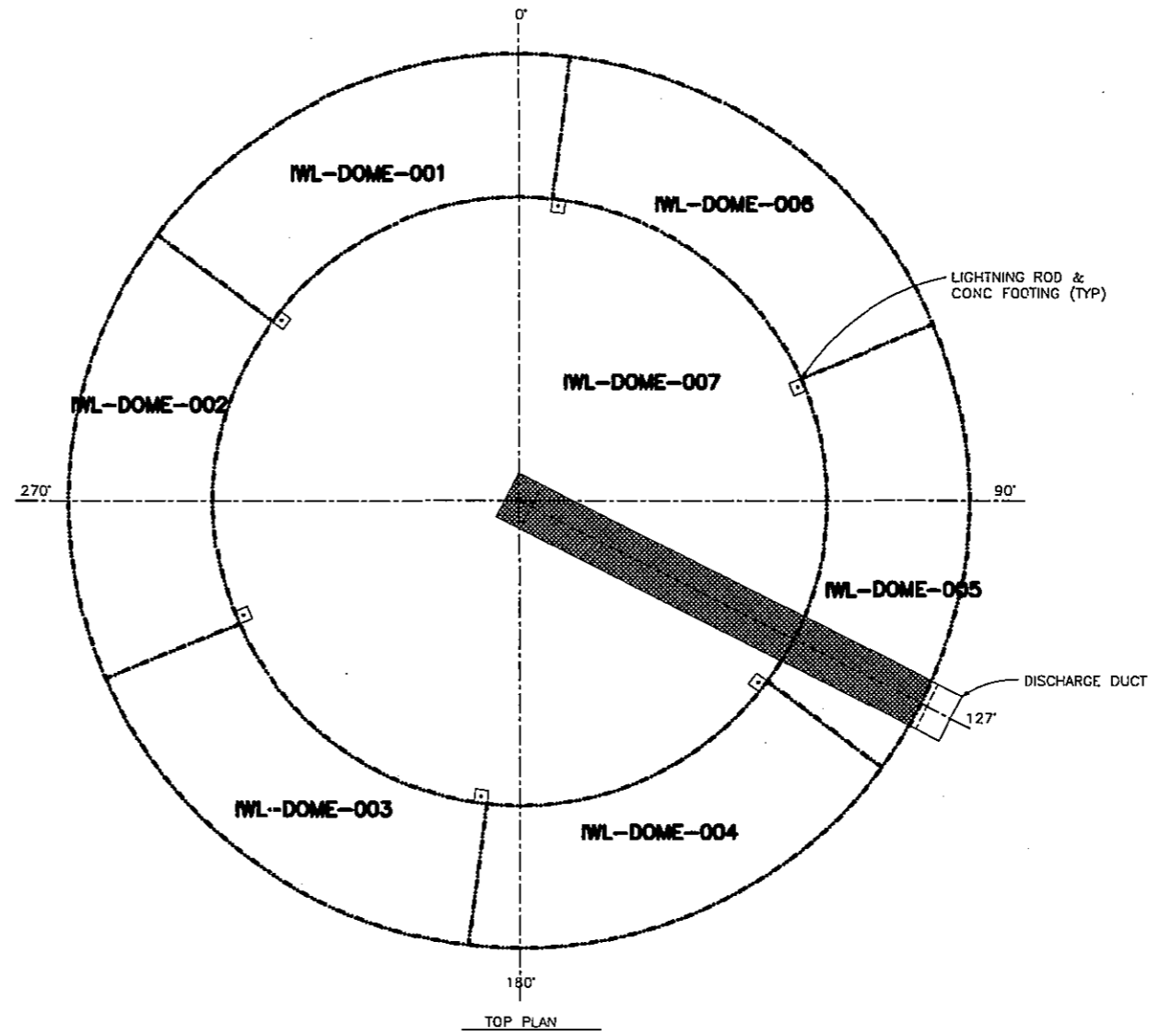

CONCRETE DOME
(EXTERIOR PROJECTED VIEW, LOOKING FROM TOP)

NOTES:
1. REFERENCE DESIGN DRAWING NUMBERS
9321-F-1130, 9321-F-1281 & 9321-F-1319.

LEGEND:
 CONCRETE SURFACE INACCESSIBLE
 ZONE BOUNDARY
 IWL-XXX-YYY INSPECTION ZONE NUMBER
(SEE DRAWING 320635 FOR INDEX)

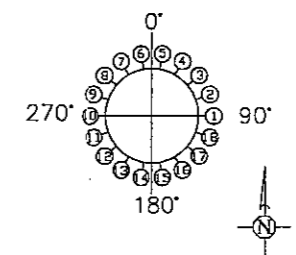

COMPUTER GENERATED DRAWING NOT TO BE HAND REVISED

REVISION SIGNATURES	
REV	PROJECT ENGINEER
00	

DWG. NO.	320793-00	
DWG. TYPE	COMPANY	
DWG. SIZE	C	
LOCATION:	INDIAN POINT UNIT 2	
TITLE:	CONTAINMENT ISI CONCRETE DOME	
- APPROVALS -		
ENGINEERING MANAGER:		
PROJECT ENGINEER:		
DESIGNER:		
DRAWN BY:		
SCALE:	DISCIPLINE CODE:	

320793-00

320793-00A

B

C

D

E

F

320834-00

INDEX OF CONCRETE INSPECTION ZONES

DRAWING NO	DESCRIPTION
320835	CONCRETE INSPECTION ZONE IWL-034-001
320836	CONCRETE INSPECTION ZONE IWL-034-002
320837	CONCRETE INSPECTION ZONE IWL-034-003
320838	CONCRETE INSPECTION ZONE IWL-043-001
320839	CONCRETE INSPECTION ZONE IWL-043-002
320840	CONCRETE INSPECTION ZONE IWL-043-003
320841	CONCRETE INSPECTION ZONE IWL-043-004
320842	CONCRETE INSPECTION ZONE IWL-068-001
320843	CONCRETE INSPECTION ZONE IWL-068-002
320844	CONCRETE INSPECTION ZONE IWL-068-003
320845	CONCRETE INSPECTION ZONE IWL-068-004
320846	CONCRETE INSPECTION ZONE IWL-088-001
320847	CONCRETE INSPECTION ZONE IWL-088-002
320848	CONCRETE INSPECTION ZONE IWL-088-003
320849	CONCRETE INSPECTION ZONE IWL-088-004
320850	CONCRETE INSPECTION ZONE IWL-088-005
320851	CONCRETE INSPECTION ZONE IWL-088-006
320852	CONCRETE INSPECTION ZONE IWL-108-001
320853	CONCRETE INSPECTION ZONE IWL-108-002
320854	CONCRETE INSPECTION ZONE IWL-108-003
320855	CONCRETE INSPECTION ZONE IWL-108-004
320856	CONCRETE INSPECTION ZONE IWL-108-005
320857	CONCRETE INSPECTION ZONE IWL-108-006
320858	CONCRETE INSPECTION ZONE IWL-128-001
320859	CONCRETE INSPECTION ZONE IWL-128-002
320860	CONCRETE INSPECTION ZONE IWL-128-003
320861	CONCRETE INSPECTION ZONE IWL-128-004
320862	CONCRETE INSPECTION ZONE IWL-128-005
320863	CONCRETE INSPECTION ZONE IWL-128-006
320864	CONCRETE INSPECTION ZONE IWL-148-001
320865	CONCRETE INSPECTION ZONE IWL-148-002
320866	CONCRETE INSPECTION ZONE IWL-148-003
320867	CONCRETE INSPECTION ZONE IWL-148-004
320868	CONCRETE INSPECTION ZONE IWL-148-005
320869	CONCRETE INSPECTION ZONE IWL-148-006

DRAWING NO	DESCRIPTION
320870	CONCRETE INSPECTION ZONE IWL-168-001
320871	CONCRETE INSPECTION ZONE IWL-168-002
320872	CONCRETE INSPECTION ZONE IWL-168-003
320873	CONCRETE INSPECTION ZONE IWL-168-004
320874	CONCRETE INSPECTION ZONE IWL-168-005
320875	CONCRETE INSPECTION ZONE IWL-168-006
320876	DOME CONCRETE INSPECTION ZONE IWL-DOME-001
320877	DOME CONCRETE INSPECTION ZONE IWL-DOME-002
320878	DOME CONCRETE INSPECTION ZONE IWL-DOME-003
320879	DOME CONCRETE INSPECTION ZONE IWL-DOME-004
320880	DOME CONCRETE INSPECTION ZONE IWL-DOME-005
320881	DOME CONCRETE INSPECTION ZONE IWL-DOME-006
320882	DOME CONCRETE INSPECTION ZONE IWL-DOME-007

REVISION USE .1 SIZE TEXT ONLY	
REVISION SIGNATURES	
REV	PROJECT ENGINEER
00	

NOTES:
 1. SEE DRAWING 320792 FOR CONCRETE WALL ROLLOUT & 320793 FOR DOME.
 2. REFERENCE DESIGN DRAWING NUMBER 9321-F-1130.

LEGEND:

- ZONE BOUNDARY
- XXXXX CONCRETE INACCESSIBLE FOR INSPECTION
- - - CONSTRUCTION JOINT
- PENETRATION
- EMBEDDED PLATE

MP-VV → COMPONENT ID
 IWE-DET-01H → INSPECTION DETAIL NUMBER

DWG. NO.	320834-00
CON EDISON	DWG. TYPE COMPANY
EDISON	DWG. SIZE D
LOCATION: INDIAN POINT UNIT 2	
TITLE: CONTAINMENT ISI INDEX TO CONCRETE ZONE DRAWINGS - APPROVALS -	
ENGINEERING MANAGER:	
PROJECT ENGINEER:	
DESIGNER:	
DRAWN BY: P CHAU	
SCALE: NONE	DISCIPLINE CODE:

COMPUTER GENERATED DRAWING NOT TO BE HAND REVISED

320834-00

320835-00



CONCRETE INSPECTION ZONE IWL-034-001
 (EXTERIOR DEVELOPED VIEW, LOOKING FROM OUTSIDE)

FOR NOTES AND LEGENDS SEE DRAWING 320835.

COMPUTER GENERATED DRAWING NOT TO BE HAND REVISED

REVISION
 USE .1 SIZE TEXT ONLY

REVISION
 SIGNATURES

REV	PROJECT ENGINEER
00	

DWG. NO.	320835-00	
CON EDISON	DWG. TYPE	COMPANY
	DWG. SIZE	D
LOCATION:	INDIAN POINT UNIT 2	
TITLE:	CONTAINMENT ISI	
	CONCRETE INSPECTION ZONE	
	IWL-034-001	
	- APPROVALS -	
ENGINEERING MANAGER:		
PROJECT ENGINEER:		
DESIGNER:		
DRAWN BY:	P. CHAU	
SCALE:	NONE	DISCIPLINE CODE:

320835-00

320836-00

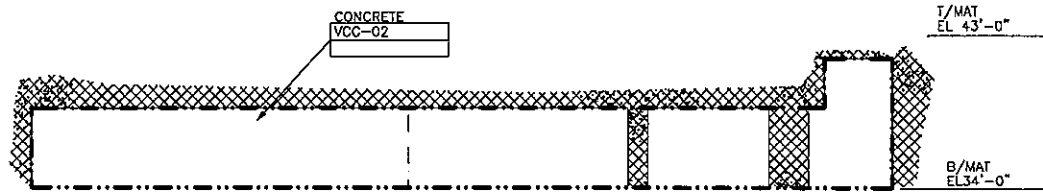

CONCRETE INSPECTION ZONE IWL-034-002
 (EXTERIOR DEVELOPED VIEW, LOOKING FROM OUTSIDE)

FOR NOTES AND LEGENDS SEE DRAWING 320835.

REVISION
 USE .1 SIZE TEXT ONLY

REVISION
 SIGNATURES

REV	PROJECT ENGINEER
00	

DWG. No. **320836-00**

CON EDISON DWG. TYPE COMPANY
 DWG. SIZE D

LOCATION: INDIAN POINT UNIT 2

TITLE: CONTAINMENT ISI
 CONCRETE INSPECTION ZONE
 IWL-034-002
 - APPROVALS -

ENGINEERING
 MANAGER:

PROJECT
 ENGINEER:

DESIGNER:

DRAWN BY: P CHAU

SCALE: NONE

DISCIPLINE
 CODE:

COMPUTER GENERATED DRAWING NOT TO BE HAND REVISED

320836-00

320837-00

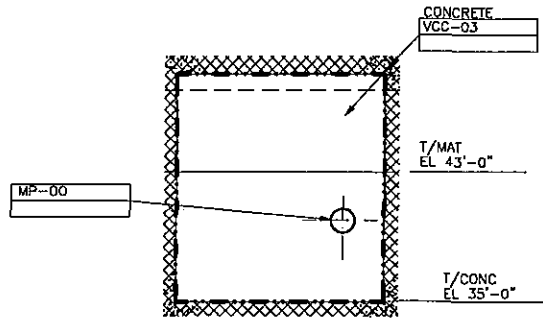

CONCRETE INSPECTION ZONE IWL-034-003
 (EXTERIOR DEVELOPED VIEW, LOOKING FROM OUTSIDE)

FOR NOTES AND LEGENDS SEE DRAWING 320835.

COMPUTER GENERATED DRAWING NOT TO BE HAND REVISED

REVISION
 USE .1 SIZE TEXT ONLY

REVISION
 SIGNATURES

REV	PROJECT ENGINEER
00	

DWG.
 NO.

320837-00

CON
 EDISON

DWG.
 TYPE COMPANY
 DWG.
 SIZE D

LOCATION: INDIAN POINT UNIT 2

TITLE: CONTAINMENT ISI
 CONCRETE INSPECTION ZONE

IWL-034-003

- APPROVALS -

ENGINEERING
 MANAGER:

PROJECT
 ENGINEER:

DESIGNER:

DRAWN
 BY: P. CHAU

SCALE: NONE

DISCIPLINE
 CODE:

320837-00

00-638073

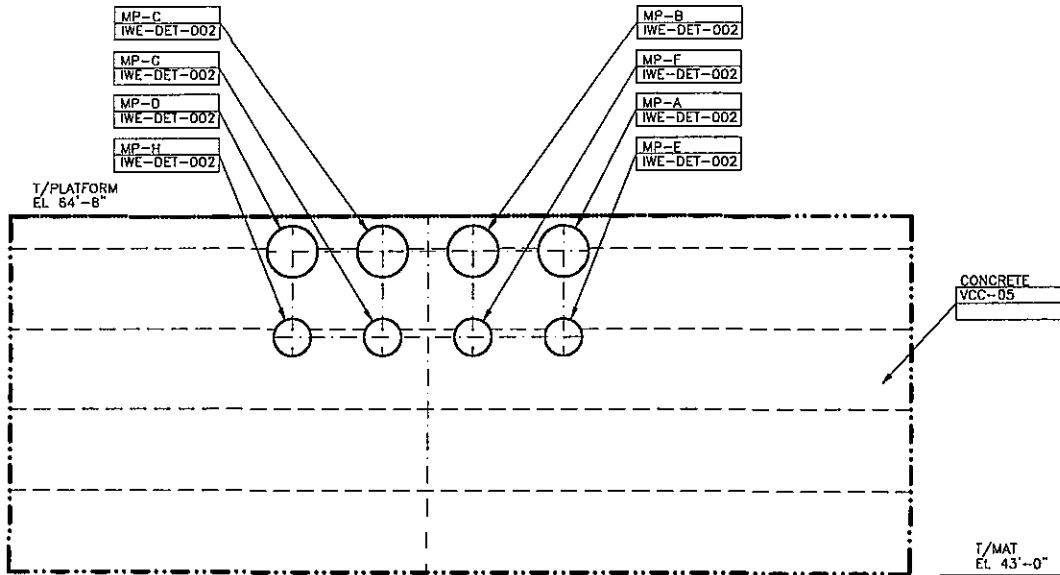

CONCRETE INSPECTION ZONE IWL-043-002
 (EXTERIOR DEVELOPED VIEW, LOOKING FROM OUTSIDE)

FOR NOTES AND LEGENDS SEE DRAWING 320835.

COMPUTER GENERATED DRAWING NOT TO BE HAND REVISED

REVISION
 USE .1 SIZE TEXT ONLY

REVISION
 SIGNATURES

REV	PROJECT ENGINEER
00	

DWG. NO. **320839-00**

CON EDISON DWG. TYPE COMPANY
 DWG. SIZE D

LOCATION: INDIAN POINT UNIT 2

TITLE: CONTAINMENT ISI
 CONCRETE INSPECTION ZONE
 IWL-043-002
 - APPROVALS -

ENGINEERING
 MANAGER:

PROJECT
 ENGINEER:

DESIGNER:

DRAWN BY: P. CHAU

SCALE: NONE

DISCIPLINE
 CODE:

320839-00

320840-00

EP-H19 IWE-DET-017	EP-H20 IWE-DET-014	EP-H21 IWE-DET-017	EP-H22 IWE-DET-017	EP-H23 IWE-DET-014	EP-H24 IWE-DET-017	EP-H25 IWE-DET-014	EP-H26 IWE-DET-017	EP-H27 IWE-DET-014	EP-H28 IWE-DET-014	EP-H29 IWE-DET-017	EP-H30 IWE-DET-014	EP-H31 IWE-DET-018
EP-H32 IWE-DET-015	EP-H33 IWE-DET-017	EP-H34 IWE-DET-017	EP-H35 IWE-DET-015	EP-H36 IWE-DET-017	EP-H37 IWE-DET-018	EP-H38 IWE-DET-018	EP-H39 IWE-DET-017	EP-H40 IWE-DET-015	EP-H41 IWE-DET-017	EP-H42 IWE-DET-018	EP-H43 IWE-DET-018	EP-H44 IWE-DET-016
EP-H45 IWE-DET-016	EP-H46 IWE-DET-015	EP-H47 IWE-DET-016	EP-H48 IWE-DET-016	EP-H49 IWE-DET-016	EP-H50 IWE-DET-016	EP-H51 IWE-DET-016	EP-H52 IWE-DET-017	EP-H53 IWE-DET-017	EP-H54 IWE-DET-016	EP-H55 IWE-DET-018	EP-H56 IWE-DET-016	EP-H57 IWE-DET-016
EP-H58 IWE-DET-016	EP-H59 IWE-DET-016	EP-H60 IWE-DET-016	EP-H61 IWE-DET-016	EP-H62 IWE-DET-019	EP-H63 IWE-DET-016	EP-H64 IWE-DET-016	EP-H65 IWE-DET-019	EP-H66 IWE-DET-019	EP-H67 IWE-DET-016	EP-H68 IWE-DET-016	EP-H69 IWE-DET-016	EP-H70 IWE-DET-016

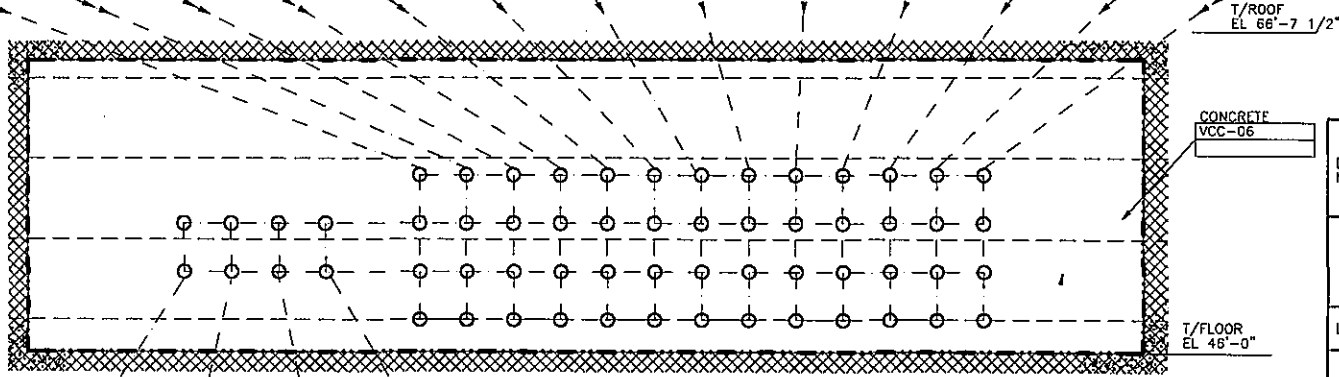

EP-H11 IWE-DET-018	EP-H12 IWE-DET-018	EP-H13 IWE-DET-018	EP-H14 IWE-DET-018
EP-H15 IWE-DET-018	EP-H16 IWE-DET-018	EP-H17 IWE-DET-018	EP-H18 IWE-DET-018

CONCRETE INSPECTION ZONE IWL-043-003
(EXTERIOR DEVELOPED VIEW, LOOKING FROM OUTSIDE)

REVISION
USE .1 SIZE TEXT ONLY

REVISION SIGNATURES	
REV	PROJECT ENGINEER
00	

DWG. NO.	320840-00		
	CON EDISON	DWG. TYPE	COMPANY
		DWG. SIZE	D
LOCATION:	INDIAN POINT UNIT 2		
TITLE:	CONTAINMENT ISI CONCRETE INSPECTION ZONE IWL-043-003 - APPROVALS -		
ENGINEERING MANAGER:			
PROJECT ENGINEER:			
DESIGNER:			
DRAWN BY:	P. CHAU		
SCALE:	NONE	DISCIPLINE CODE:	

FOR NOTES AND LEGENDS SEE DRAWING 320835.

COMPUTER GENERATED DRAWING NOT TO BE HAND REVISED

320840-00

320841-00

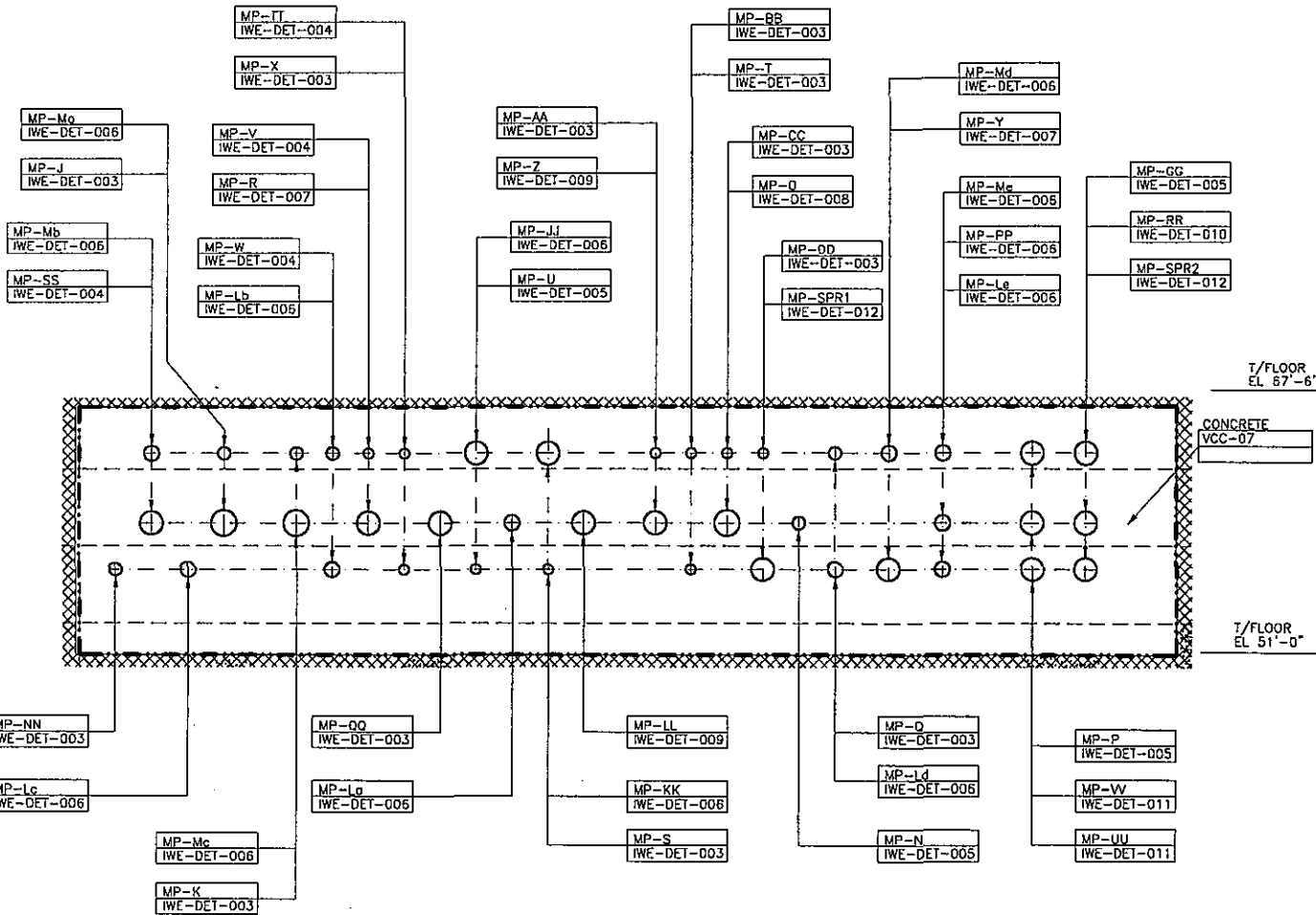

CONCRETE INSPECTION ZONE IWL-043-004
 (EXTERIOR DEVELOPED VIEW, LOOKING FROM OUTSIDE)

FOR NOTES AND LEGENDS SEE DRAWING 320835.

COMPUTER GENERATED DRAWING NOT TO BE HAND REVISED

REVISION
 USE .1 SIZE TEXT ONLY

REVISION
 SIGNATURES

REV	PROJECT ENGINEER
00	

DWG. NO. **320841-00**

CON EDISON	DWG. TYPE COMPANY
	DWG. SIZE D

LOCATION: INDIAN POINT UNIT 2

TITLE: CONTAINMENT ISI
 CONCRETE INSPECTION ZONE
 IWL-043-004
 - APPROVALS -

ENGINEERING MANAGER:

PROJECT ENGINEER:

DESIGNER:

DRAWN BY: P. CHAU

SCALE: NONE	DISCIPLINE CODE:
-------------	------------------

320841-00

320842-00

REVISION
USE .1 SIZE TEXT ONLY

REVISION
SIGNATURES

REV PROJECT ENGINEER

00

DWG.
NO.

320842-00

CON
EDISON

DWG.
TYPE COMPANY
DWG.
SIZE D

LOCATION: INDIAN POINT UNIT 2

TITLE: CONTAINMENT ISI
CONCRETE INSPECTION ZONE

IWL-068-001

- APPROVALS -

ENGINEERING
MANAGER:

PROJECT
ENGINEER:

DESIGNER:

DRAWN
BY: P. CHAU

SCALE: NONE

DISCIPLINE
CODE:

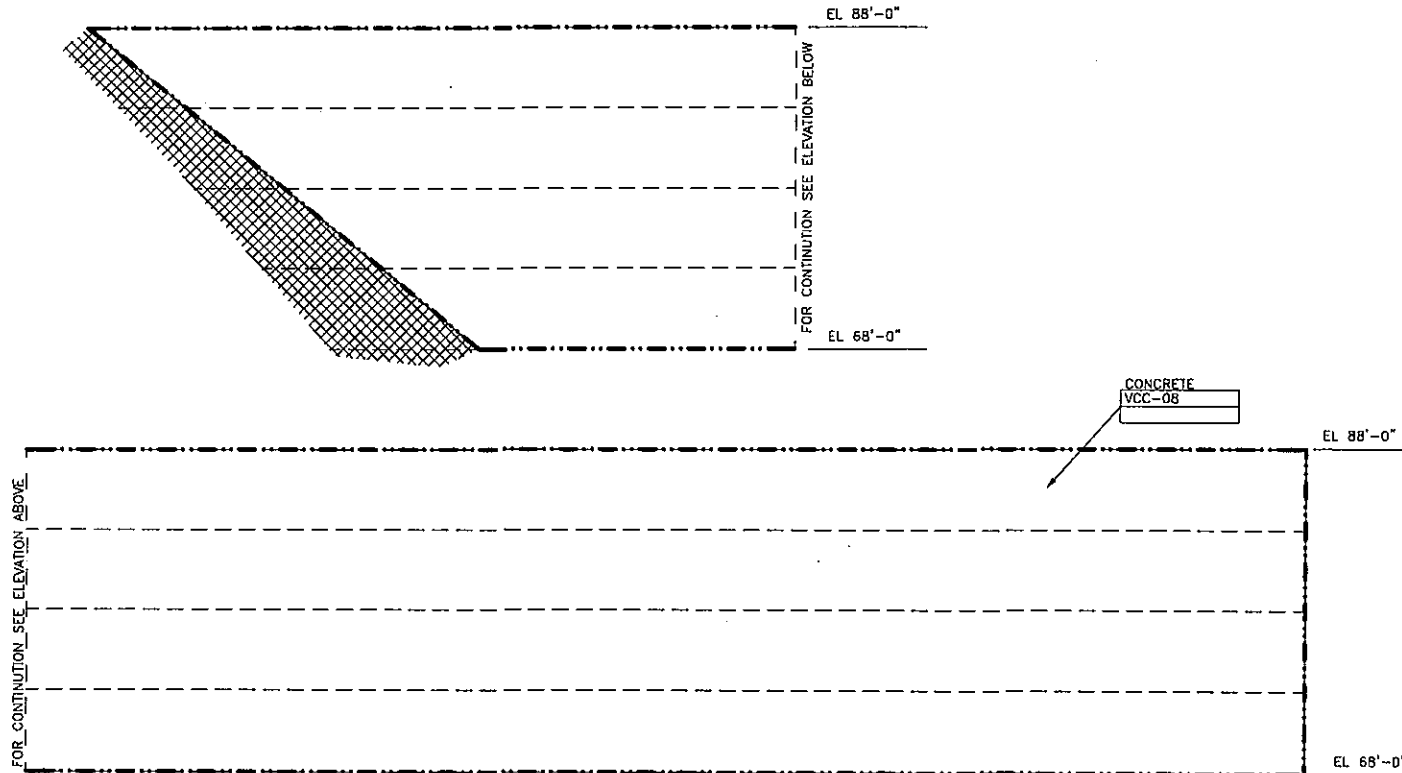

CONCRETE INSPECTION ZONE IWL-068-001
(EXTERIOR DEVELOPED VIEW, LOOKING FROM OUTSIDE)

FOR NOTES AND LEGENDS SEE DRAWING 320835.

COMPUTER GENERATED DRAWING NOT TO BE HAND REVISED

320842-00

320843-00

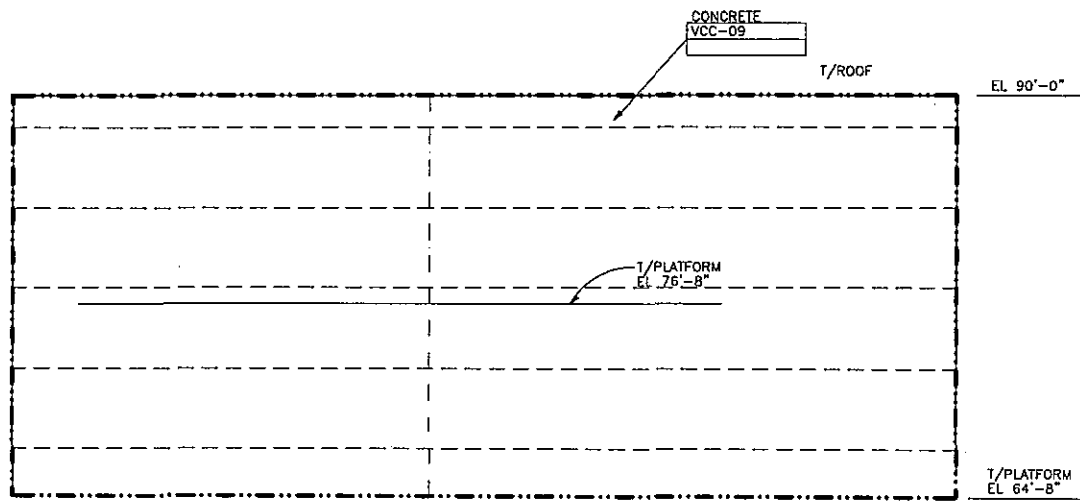

CONCRETE INSPECTION ZONE IWL-068-002
 (EXTERIOR DEVELOPED VIEW, LOOKING FROM OUTSIDE)

REVISION
 USE .1 SIZE TEXT ONLY

REVISION SIGNATURES	
REV	PROJECT ENGINEER
00	

DWG. NO.	320843-00	
DWG. TYPE	CON	COMPANY
DWG. SIZE	EDISON	D
LOCATION:	INDIAN POINT UNIT 2	
TITLE:	CONTAINMENT ISI	
	CONCRETE INSPECTION ZONE	
	IWL-068-002	
	- APPROVALS -	
ENGINEERING MANAGER:		
PROJECT ENGINEER:		
DESIGNER:		
DRAWN BY:	P. CHAU	
SCALE:	NONE	DISCIPLINE CODE:

COMPUTER GENERATED DRAWING NOT TO BE HAND REVISED

FOR NOTES AND LEGENDS SEE DRAWING 320835.

320843-00

320844-00

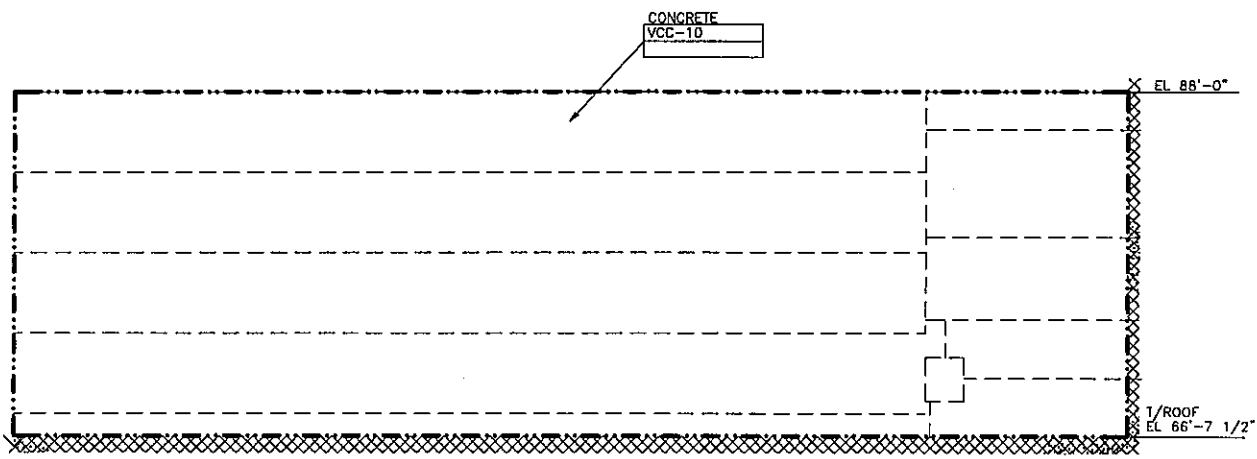

CONCRETE INSPECTION ZONE IWL-068-003
 (EXTERIOR DEVELOPED VIEW, LOOKING FROM OUTSIDE)

REVISION USE .1 SIZE TEXT ONLY	
REVISION SIGNATURES	
REV	PROJECT ENGINEER
00	

DWG. NO.	320844-00	
DWG. TYPE	CON EDISON COMPANY	
DWG. SIZE	D	
LOCATION:	INDIAN POINT UNIT 2	
TITLE:	CONTAINMENT ISI CONCRETE INSPECTION ZONE IWL-068-003 - APPROVALS -	
ENGINEERING MANAGER:		
PROJECT ENGINEER:		
DESIGNER:		
DRAWN BY:	P. CHAU	
SCALE:	NONE	DISCIPLINE CODE:

FOR NOTES AND LEGENDS SEE DRAWING 320835.

COMPUTER GENERATED DRAWING NOT TO BE HAND REVISED

320844-00

320845-00

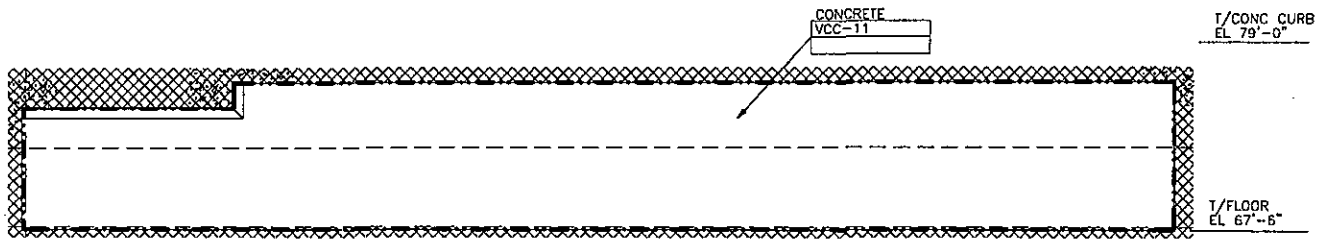

CONCRETE INSPECTION ZONE IWL-068-004
 (EXTERIOR DEVELOPED VIEW, LOOKING FROM OUTSIDE)

REVISION
 USE .1 SIZE TEXT ONLY

REVISION
 SIGNATURES

REV	PROJECT ENGINEER
00	

DWG.
NO.

320845-00

CON EDISON

DWG. TYPE COMPANY
 DWG. SIZE D

LOCATION: INDIAN POINT UNIT 2

TITLE: CONTAINMENT ISI
 CONCRETE INSPECTION ZONE

IWL-068-004

- APPROVALS -

ENGINEERING
MANAGER:

PROJECT
ENGINEER:

DESIGNER:

DRAWN
BY: P. CHAU

SCALE: NONE

DISCIPLINE
CODE:

FOR NOTES AND LEGENDS SEE DRAWING 320835.

COMPUTER GENERATED DRAWING NOT TO BE HAND REVISED

320845-00

320846-00

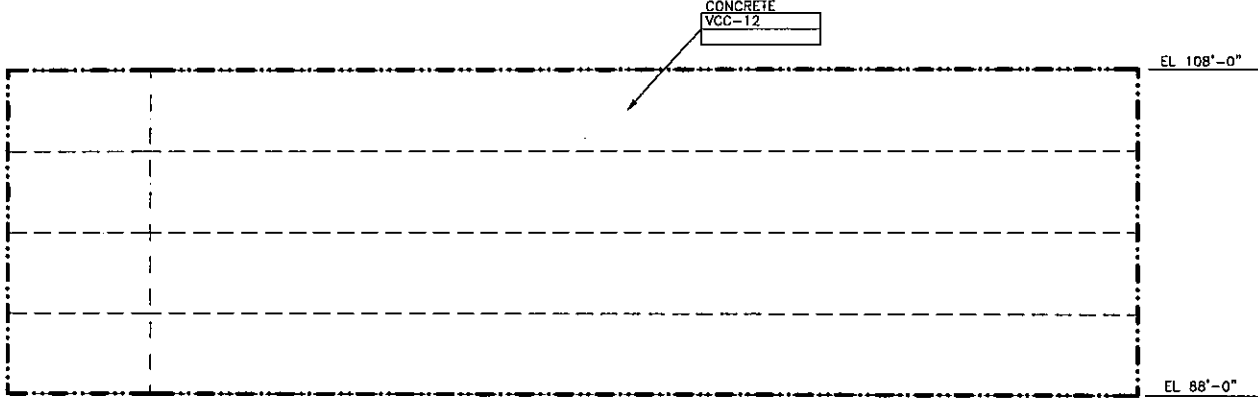

CONCRETE INSPECTION ZONE IWL-088-001
 (EXTERIOR DEVELOPED VIEW, LOOKING FROM OUTSIDE)

FOR NOTES AND LEGENDS SEE DRAWING 320835.

COMPUTER GENERATED DRAWING NOT TO BE HAND REVISED

REVISION USE .1 SIZE TEXT ONLY	
REVISION SIGNATURES	
REV	PROJECT ENGINEER
00	

DWG. NO.	320846-00	
CON EDISON	DWG. TYPE	COMPANY
	DWG. SIZE	D
LOCATION: INDIAN POINT UNIT 2		
TITLE: CONTAINMENT ISI		
CONCRETE INSPECTION ZONE		
IWL-088-001		
- APPROVALS -		
ENGINEERING MANAGER:		
PROJECT ENGINEER:		
DESIGNER:		
DRAWN BY: P. CHAU		
SCALE:	NONE	DISCIPLINE CODE:

320846-00

320847-00

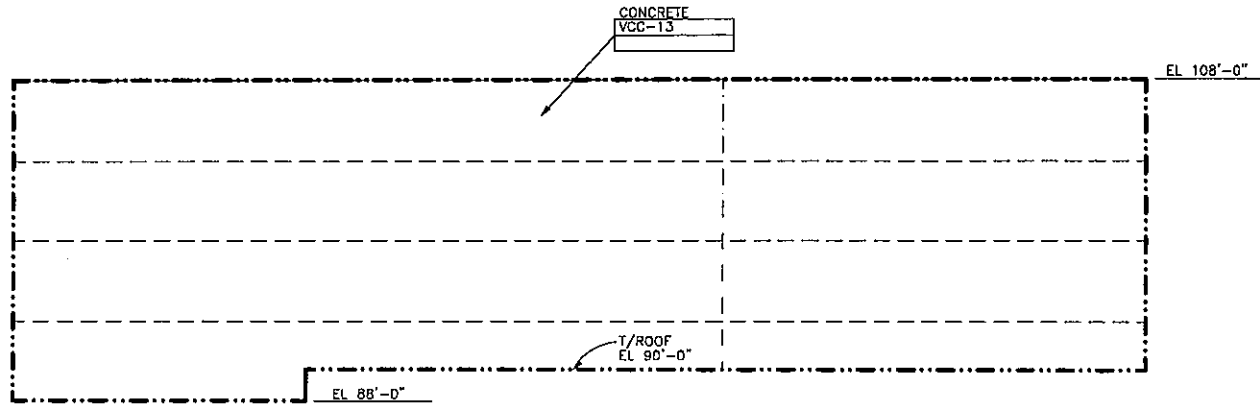

CONCRETE INSPECTION ZONE IWL-088-002
 (EXTERIOR DEVELOPED VIEW, LOOKING FROM OUTSIDE)

FOR NOTES AND LEGENDS SEE DRAWING 320835.

COMPUTER GENERATED DRAWING NOT TO BE HAND REVISED

REVISION
 USE .1 SIZE TEXT ONLY

REVISION
 SIGNATURES

REV	PROJECT ENGINEER
00	

DWG.
 NO.

320847-00

CON
 EDISON

DWG.
 TYPE COMPANY
 DWG.
 SIZE D

LOCATION: INDIAN POINT UNIT 2

TITLE: CONTAINMENT ISI
 CONCRETE INSPECTION ZONE

IWL-088-002

- APPROVALS -

ENGINEERING
 MANAGER:

PROJECT
 ENGINEER:

DESIGNER:

DRAWN
 BY: P. CHAU

SCALE: NONE

DISCIPLINE
 CODE:

320847-00

320848-00

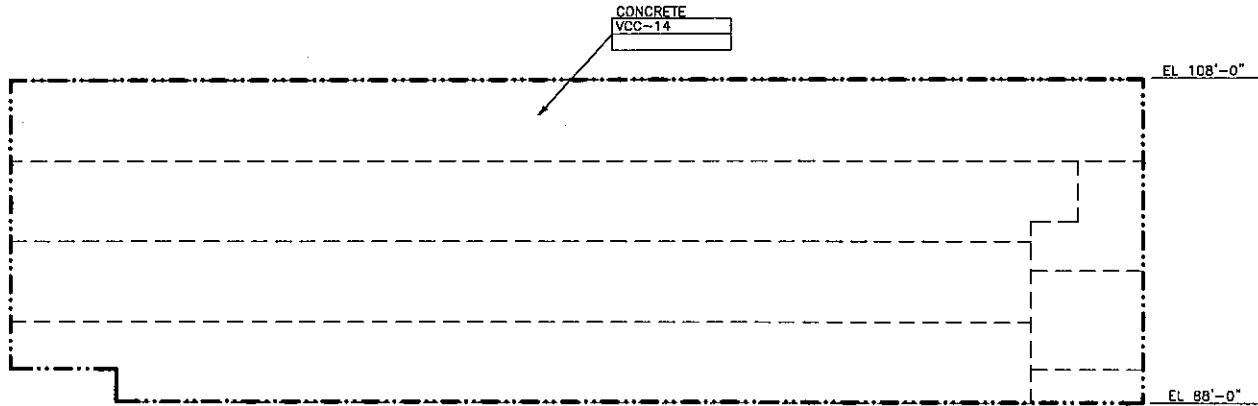

CONCRETE INSPECTION ZONE MI-088-003
 (EXTERIOR DEVELOPED VIEW, LOOKING FROM OUTSIDE)

FOR NOTES AND LEGENDS SEE DRAWING 320835.

COMPUTER GENERATED DRAWING NOT TO BE HAND REVISED

REVISION	
USE .1 SIZE TEXT ONLY	
REVISION SIGNATURES	
REV	PROJECT ENGINEER
00	

DWG. NO.	320848-00	
	CON EDISON	DWG. TYPE COMPANY
		DWG. SIZE D
LOCATION:	INDIAN POINT UNIT 2	
TITLE:	CONTAINMENT ISI	
	CONCRETE INSPECTION ZONE	
	IWL-088-003	
	- APPROVALS -	
ENGINEERING MANAGER:		
PROJECT ENGINEER:		
DESIGNER:		
DRAWN BY:	P. CHAU	
SCALE:	NONE	DISCIPLINE CODE:

320848-00

320849-00

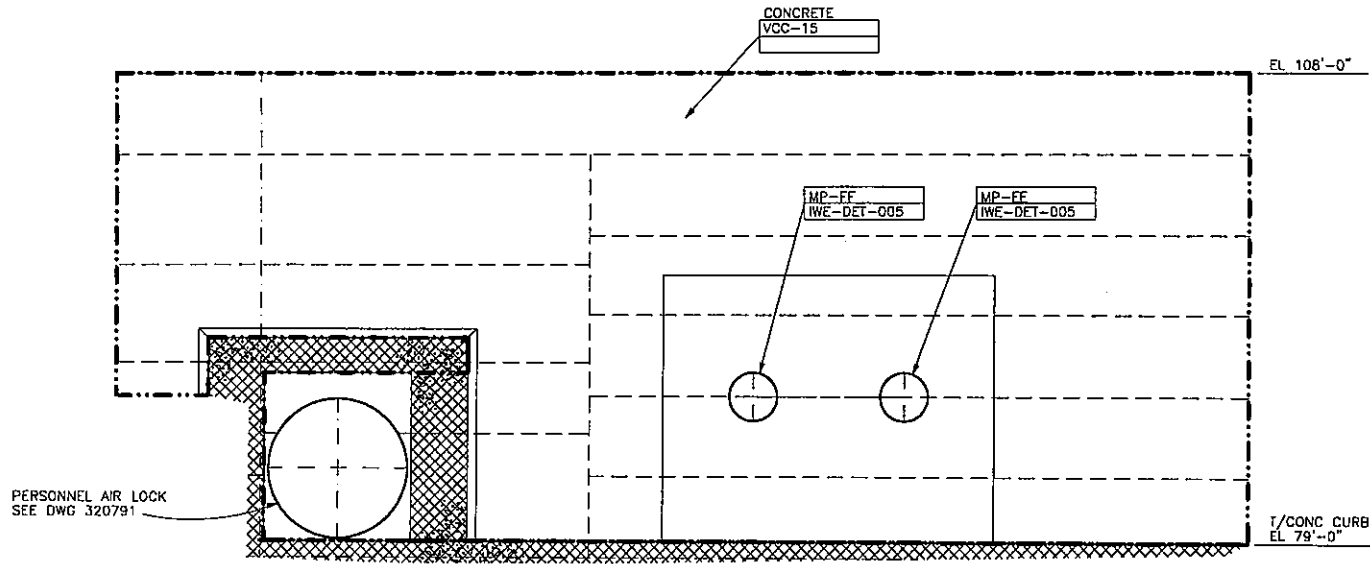

CONCRETE INSPECTION ZONE IWL-088-004
(EXTERIOR DEVELOPED VIEW, LOOKING FROM OUTSIDE)

FOR NOTES AND LEGENDS SEE DRAWING 320835.

COMPUTER GENERATED DRAWING NOT TO BE HAND REVISED

REVISION	
USE .1 SIZE TEXT ONLY	
REVISION SIGNATURES	
REV	PROJECT ENGINEER
00	

DWG. NO.	320849-00	
	DWG. TYPE	COMPANY
	DWG. SIZE	D
LOCATION:	INDIAN POINT UNIT 2	
TITLE:	CONTAINMENT ISI	
	CONCRETE INSPECTION ZONE	
	IWL-088-004	
	- APPROVALS -	
ENGINEERING MANAGER:		
PROJECT ENGINEER:		
DESIGNER:		
DRAWN BY:	P. CHAU	
SCALE:	NONE	DISCIPLINE CODE:

320849-00

00-098072

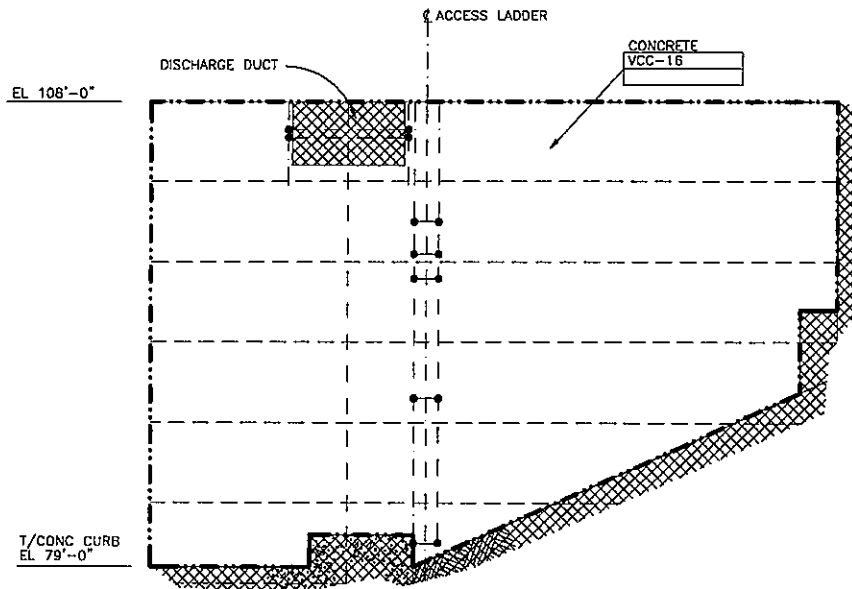

CONCRETE INSPECTION ZONE IWL-088-005
 (EXTERIOR DEVELOPED VIEW, LOOKING FROM OUTSIDE)

FOR NOTES AND LEGENDS SEE DRAWING J20835.

COMPUTER GENERATED DRAWING NOT TO BE HAND REVISED

REVISION USE .1 SIZE TEXT ONLY	
REVISION SIGNATURES	
REV	PROJECT ENGINEER
00	

DWG. NO.	320850-00	
CON EDISON	DWG. TYPE	COMPANY
	DWG. SIZE	D
LOCATION:	INDIAN POINT UNIT 2	
TITLE:	CONTAINMENT ISI	
	CONCRETE INSPECTION ZONE	
	IWL-088-005	
	- APPROVALS -	
ENGINEERING MANAGER:		
PROJECT ENGINEER:		
DESIGNER:		
DRAWN BY:	P. CHAU	
SCALE:	NONE	DISCIPLINE CODE:

320850-00

320851-00

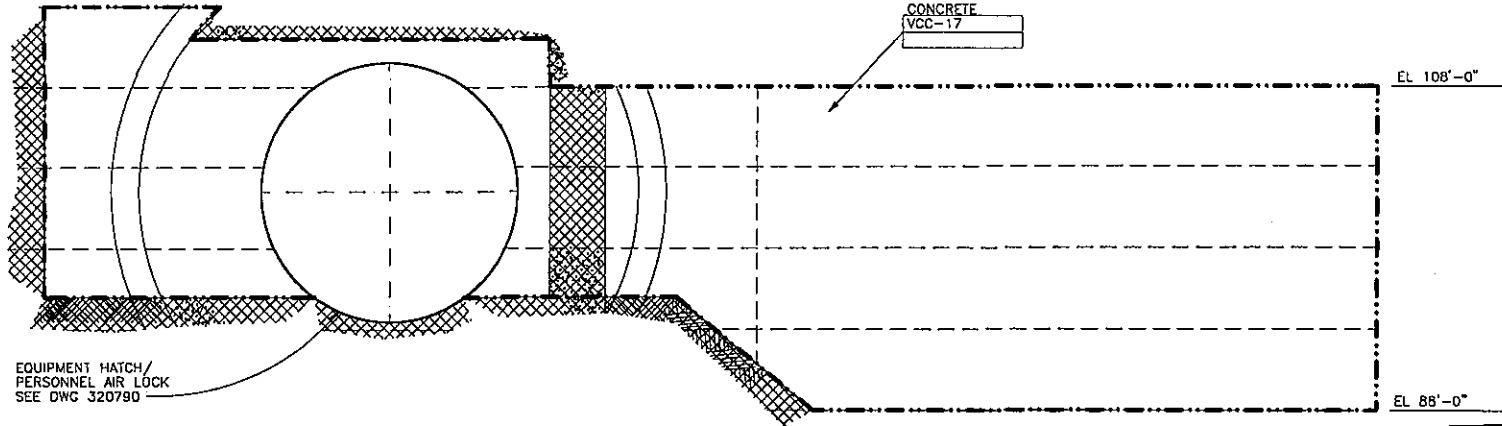

EQUIPMENT HATCH/
PERSONNEL AIR LOCK
SEE DWG 320790

CONCRETE INSPECTION ZONE IWL-088-006
(EXTERIOR DEVELOPED VIEW, LOOKING FROM OUTSIDE)

REVISION
USE .1 SIZE TEXT ONLY

REVISION SIGNATURES	
REV	PROJECT ENGINEER
00	

DWG. NO.

320851-00

CON EDISON

DWG. TYPE COMPANY
DWC. SIZE D

LOCATION: INDIAN POINT UNIT 2

TITLE: CONTAINMENT ISI
CONCRETE INSPECTION ZONE
IWL-088-006
- APPROVALS -

ENGINEERING MANAGER:

PROJECT ENGINEER:

DESIGNER:

DRAWN BY: P. CHAU

SCALE: NONE

DISCIPLINE CODE:

FOR NOTES AND LEGENDS SEE DRAWING 320835.

COMPUTER GENERATED DRAWING NOT TO BE HAND REVISED

320851-00

320852-00

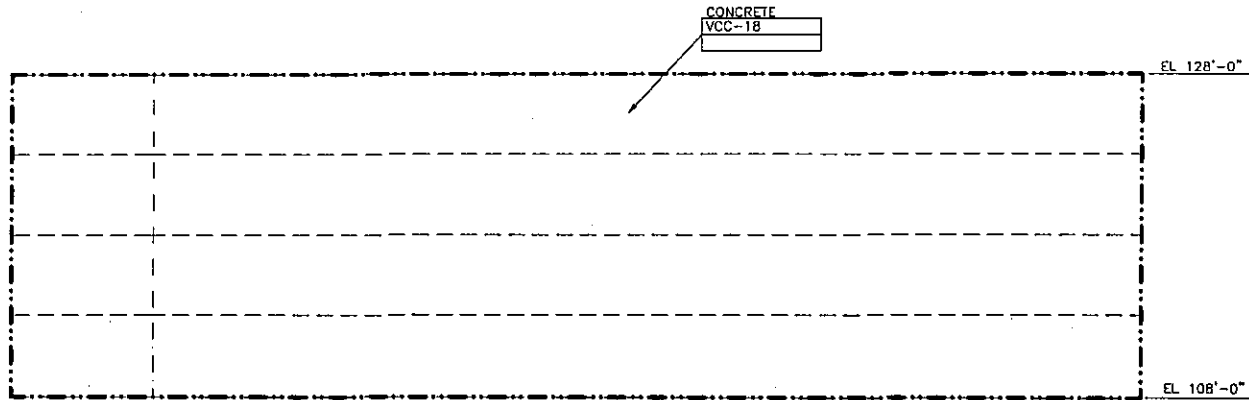

CONCRETE INSPECTION ZONE IWL-108-001
 (EXTERIOR DEVELOPED VIEW, LOOKING FROM OUTSIDE)

REVISION
 USE .1 SIZE TEXT ONLY

REVISION
 SIGNATURES

REV	PROJECT ENGINEER
00	

DWG.
NO.

320852-00

CON EDISON
 DWG. TYPE COMPANY
 DWG. SIZE D

LOCATION: INDIAN POINT UNIT 2

TITLE: CONTAINMENT ISI
 CONCRETE INSPECTION ZONE
 IWL-108-001
 - APPROVALS -

ENGINEERING
MANAGER:

PROJECT
ENGINEER:

DESIGNER:

DRAWN
BY: P. CHAU

SCALE: NONE

DISCIPLINE
CODE:

FOR NOTES AND LEGENDS SEE DRAWING 320835.

COMPUTER GENERATED DRAWING NOT TO BE HAND REVISED

320852-00

320853-00

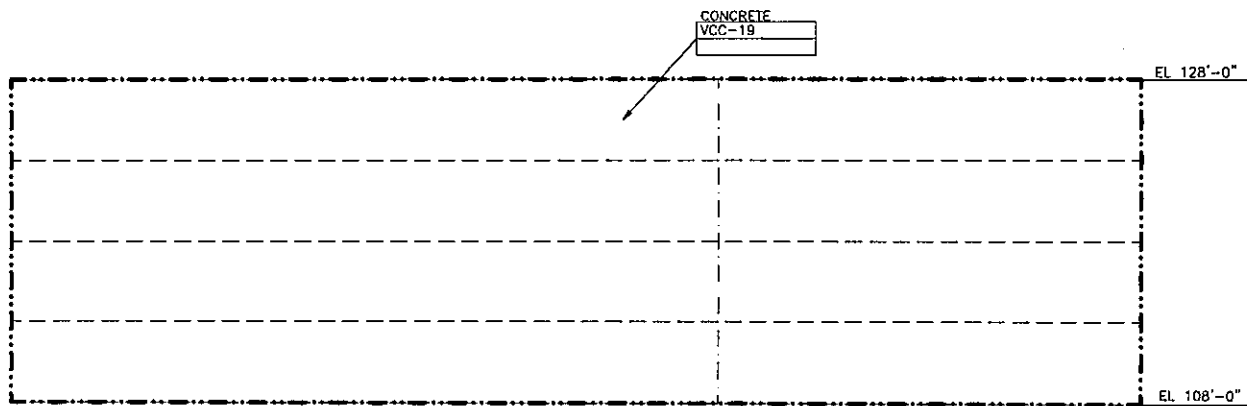

CONCRETE INSPECTION ZONE IWL-108-002
 (EXTERIOR DEVELOPED VIEW, LOOKING FROM OUTSIDE)

REVISION
 USE .1 SIZE TEXT ONLY

REVISION SIGNATURES	
REV	PROJECT ENGINEER
00	

DWG. NO.	320853-00	
	CON EDISON	DWG. TYPE COMPANY
		DWG. SIZE D
LOCATION:	INDIAN POINT UNIT 2	
TITLE:	CONTAINMENT ISI	
	CONCRETE INSPECTION ZONE	
	IWL-108-002	
	- APPROVALS -	
ENGINEERING MANAGER:		
PROJECT ENGINEER:		
DESIGNER:		
DRAWN BY:	P. CHAU	
SCALE:	NONE	DISCIPLINE CODE:

FOR NOTES AND LEGENDS SEE DRAWING 320B35.

COMPUTER GENERATED DRAWING NOT TO BE HAND REVISED

320853-00

320854-00

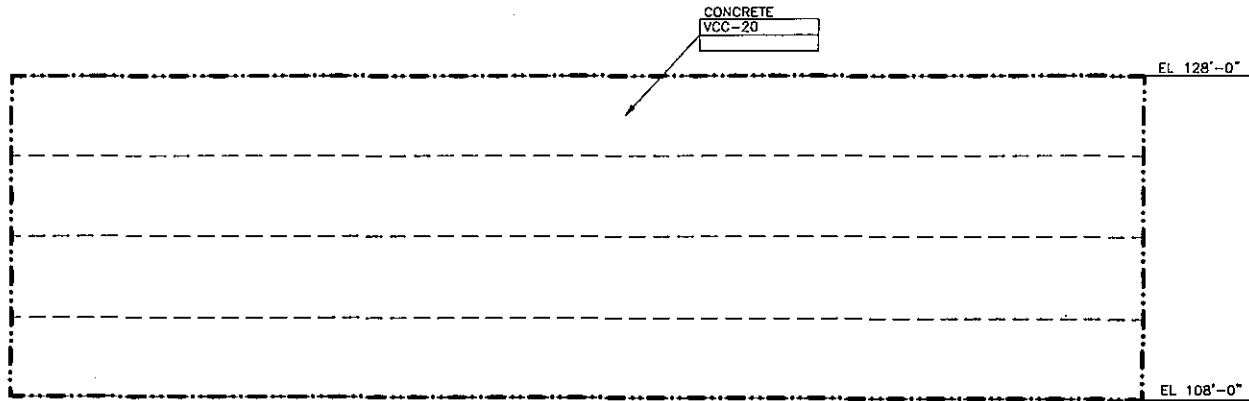

CONCRETE INSPECTION ZONE IWL-108-003
 (EXTERIOR DEVELOPED VIEW, LOOKING FROM OUTSIDE)

REVISION USE .1 SIZE TEXT ONLY	
REVISION SIGNATURES	
REV	PROJECT ENGINEER
00	

DWG. NO.	320854-00	
CON EDISON	DWG. TYPE	COMPANY
	DWG. SIZE	D
LOCATION: INDIAN POINT UNIT 2		
TITLE: CONTAINMENT ISI		
CONCRETE INSPECTION ZONE		
IWL-108-003		
- APPROVALS -		
ENGINEERING MANAGER:		
PROJECT ENGINEER:		
DESIGNER:		
DRAWN BY:	P. CHAU	
SCALE:	NONE	DISCIPLINE CODE:

FOR NOTES AND LEGENDS SEE DRAWING 320835.

COMPUTER GENERATED DRAWING NOT TO BE HAND REVISED

320854-00

320855-00

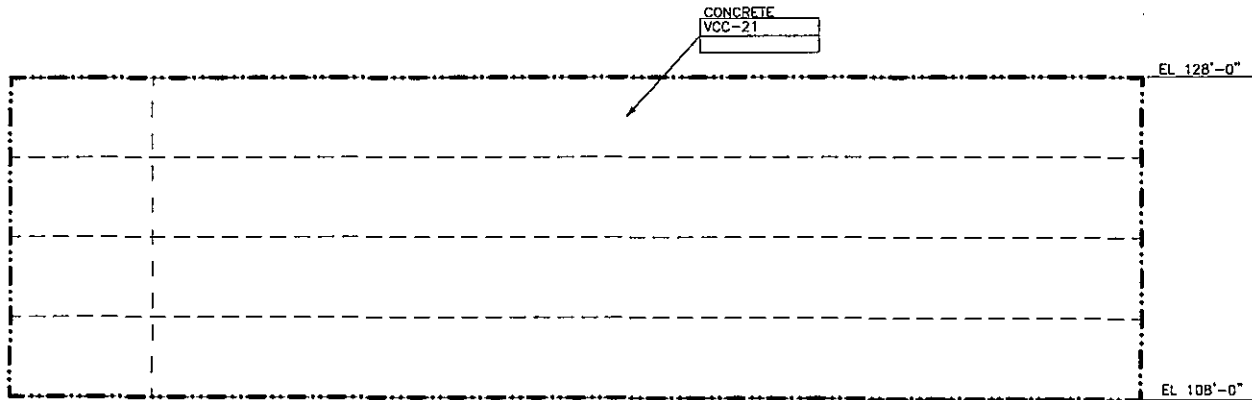

CONCRETE INSPECTION ZONE IWL-108-004
 (EXTERIOR DEVELOPED VIEW, LOOKING FROM OUTSIDE)

FOR NOTES AND LEGENDS SEE DRAWING 320835.

COMPUTER GENERATED DRAWING NOT TO BE HAND REVISED

REVISION
 USE .1 SIZE TEXT ONLY

REVISION SIGNATURES	
REV	PROJECT ENGINEER
00	

DWG. NO.

320855-00

CON EDISON

DWG. TYPE COMPANY
 DWG. SIZE D

LOCATION: INDIAN POINT UNIT 2

TITLE: CONTAINMENT ISI
 CONCRETE INSPECTION ZONE

IWL-108-004

- APPROVALS -

ENGINEERING MANAGER:

PROJECT ENGINEER:

DESIGNER:

DRAWN BY: P. CHAU

SCALE: NONE

DISCIPLINE CODE:

320855-00

320856-00

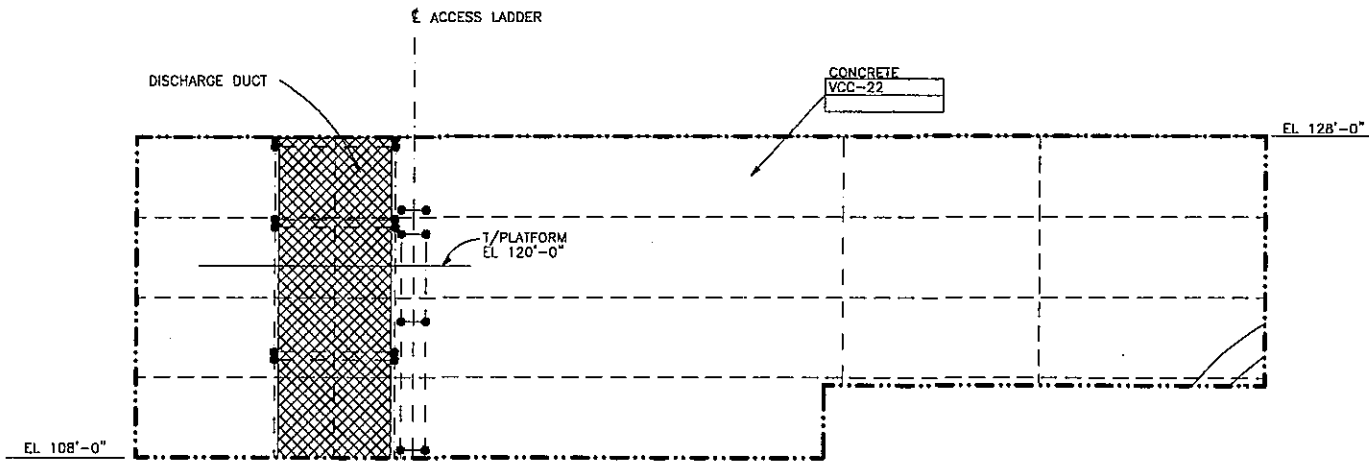

CONCRETE INSPECTION ZONE IWL-108-005
 (EXTERIOR DEVELOPED VIEW, LOOKING FROM OUTSIDE)

FOR NOTES AND LEGENDS SEE DRAWING 320835.

COMPUTER GENERATED DRAWING NOT TO BE HAND REVISED

REVISION
 USE .1 SIZE TEXT ONLY

REVISION SIGNATURES	
REV	PROJECT ENGINEER
00	

DWG. NO.	320856-00	
CON EDISON	DWG. TYPE	COMPANY
	DWG. SIZE	D
LOCATION: INDIAN POINT UNIT 2		
TITLE: CONTAINMENT ISI		
CONCRETE INSPECTION ZONE		
IWL-108-005		
- APPROVALS -		
ENGINEERING MANAGER:		
PROJECT ENGINEER:		
DESIGNER:		
DRAWN BY:	P. CHAU	
SCALE:	NONE	DISCIPLINE CODE:

320856-00

320857-00

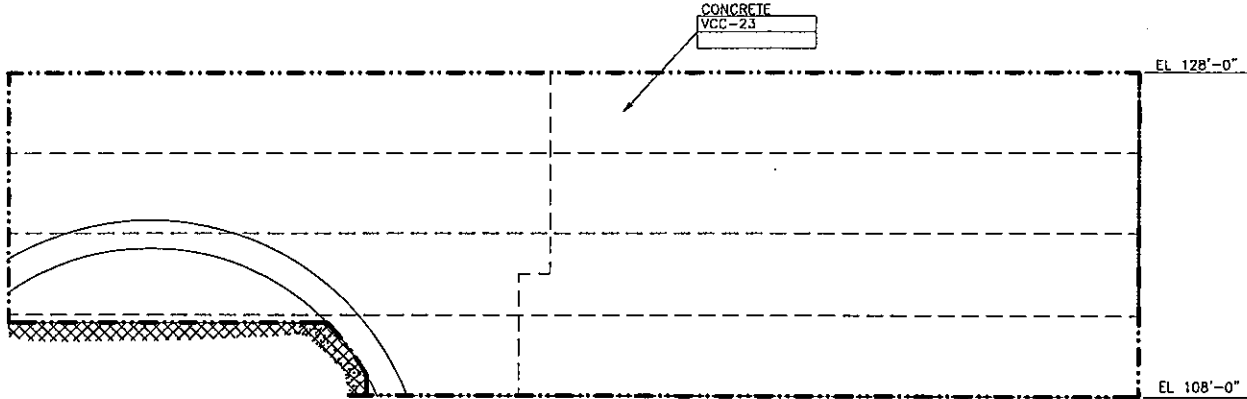

CONCRETE INSPECTION ZONE IWL-108-006
 (EXTERIOR DEVELOPED VIEW, LOOKING FROM OUTSIDE)

FOR NOTES AND LEGENDS SEE DRAWING 320835.

COMPUTER GENERATED DRAWING NOT TO BE HAND REVISED

REVISION
 USE .1 SIZE TEXT ONLY

REVISION SIGNATURES	
REV	PROJECT ENGINEER
00	

DWG. NO.	320857-00	
	CON EDISON	DWG. TYPE COMPANY
		DWG. SIZE D
LOCATION:	INDIAN POINT UNIT 2	
TITLE:	CONTAINMENT ISI	
	CONCRETE INSPECTION ZONE	
	IWL-108-006	
	- APPROVALS -	
ENGINEERING MANAGER:		
PROJECT ENGINEER:		
DESIGNER:		
DRAWN BY:	P. CHAU	
SCALE:	NONE	DISCIPLINE CODE:

320857-00

320858-00

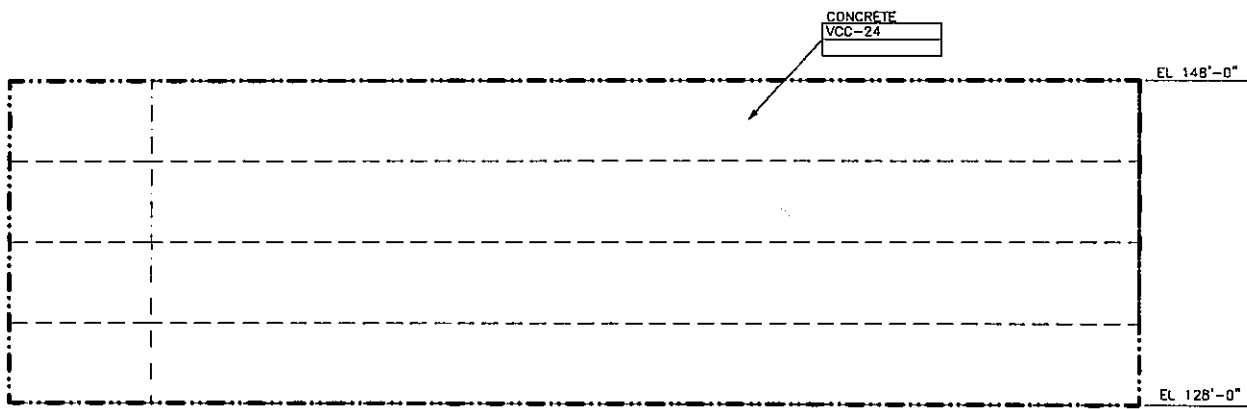

CONCRETE INSPECTION ZONE IWL-128-001
 (EXTERIOR DEVELOPED VIEW, LOOKING FROM OUTSIDE)

FOR NOTES AND LEGENDS SEE DRAWING 320835.

COMPUTER GENERATED DRAWING NOT TO BE HAND REVISED

REVISION
 USE .1 SIZE TEXT ONLY

REVISION SIGNATURES	
REV	PROJECT ENGINEER
00	

DWG. NO.	320858-00	
CON EDISON	DWG. TYPE	COMPANY
	DWG. SIZE	D
LOCATION: INDIAN POINT UNIT 2		
TITLE: CONTAINMENT ISI		
CONCRETE INSPECTION ZONE		
IWL-128-001		
- APPROVALS -		
ENGINEERING MANAGER:		
PROJECT ENGINEER:		
DESIGNER:		
DRAWN BY:	P. CHAU	
SCALE:	NONE	DISCIPLINE CODE:

320858-00

320859-00

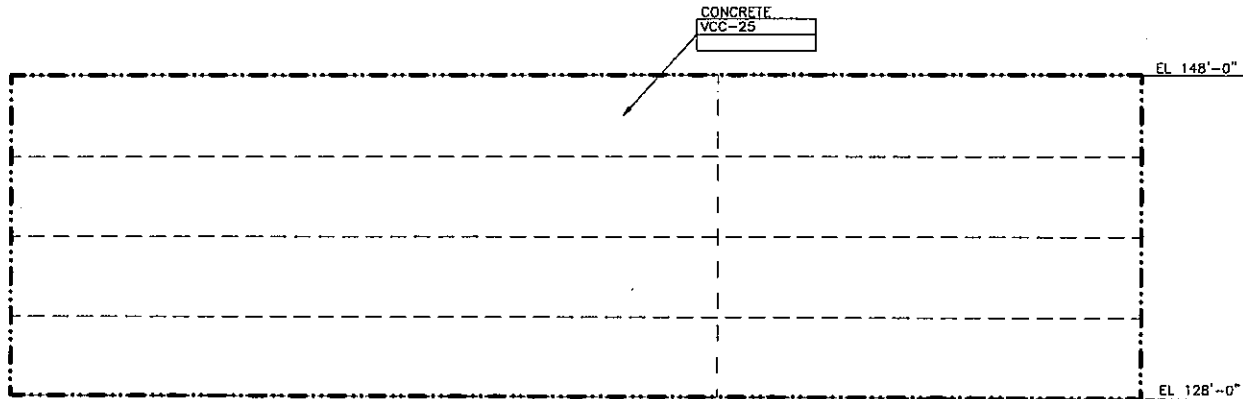

CONCRETE INSPECTION ZONE IWL-128-002
 (EXTERIOR DEVELOPED VIEW, LOOKING FROM OUTSIDE)

REVISION USE .1 SIZE TEXT ONLY	
REVISION SIGNATURES	
REV	PROJECT ENGINEER
00	

DWG. NO.	320859-00	
CON EDISON	DWG. TYPE	COMPANY
	DWG. SIZE	D
LOCATION: INDIAN POINT UNIT 2		
TITLE: CONTAINMENT ISI		
CONCRETE INSPECTION ZONE		
IWL-128-002		
- APPROVALS -		
ENGINEERING MANAGER:		
PROJECT ENGINEER:		
DESIGNER:		
DRAWN BY:	P. CHAU	
SCALE:	NONE	DISCIPLINE CODE:

FOR NOTES AND LEGENDS SEE DRAWING 320835.

COMPUTER GENERATED DRAWING NOT TO BE HAND REVISED

320859-00

00-09807E
320860-00

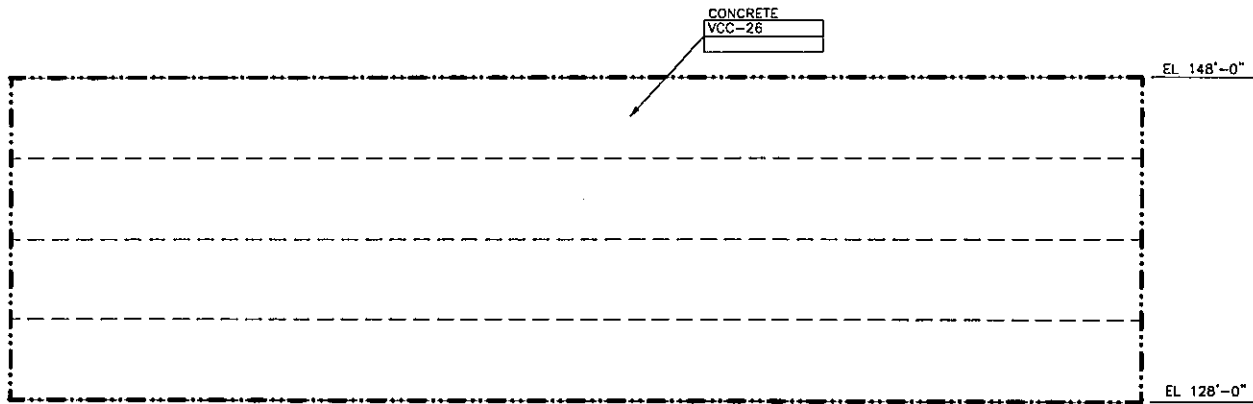

CONCRETE INSPECTION ZONE IWL-128-003
 (EXTERIOR DEVELOPED VIEW, LOOKING FROM OUTSIDE)

REVISION
 USE .1 SIZE TEXT ONLY

REVISION SIGNATURES	
REV	PROJECT ENGINEER
00	

DWG. NO.	320860-00	
	CON	DWG. TYPE COMPANY
	EDISON	DWG. SIZE D
LOCATION:	INDIAN POINT UNIT 2	
TITLE:	CONTAINMENT ISI	
	CONCRETE INSPECTION ZONE	
	IWL-128-003	
	- APPROVALS -	
ENGINEERING MANAGER:		
PROJECT ENGINEER:		
DESIGNER:		
DRAWN BY:	P. CHAU	
SCALE:	NONE	DISCIPLINE CODE:

FOR NOTES AND LEGENDS SEE DRAWING 320835.

COMPUTER GENERATED DRAWING NOT TO BE HAND REVISED

320860-00

320861-00

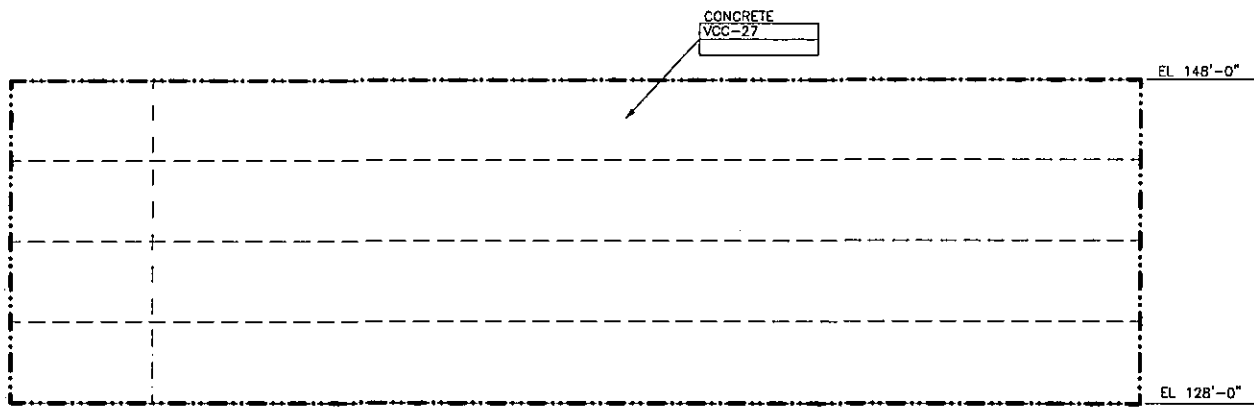

CONCRETE INSPECTION ZONE IWL-128-004
 (EXTERIOR DEVELOPED VIEW, LOOKING FROM OUTSIDE)

REVISION
 USE .1 SIZE TEXT ONLY

REVISION SIGNATURES	
REV	PROJECT ENGINEER
00	

DWG. NO.	320861-00	
CON EDISON	DWG. TYPE	COMPANY
	DWG. SIZE	D
LOCATION:	INDIAN POINT UNIT 2	
TITLE:	CONTAINMENT ISI	
	CONCRETE INSPECTION ZONE	
	IWL-128-004	
	- APPROVALS -	
ENGINEERING MANAGER:		
PROJECT ENGINEER:		
DESIGNER:		
DRAWN BY:	P. CHAU	
SCALE:	NONE	DISCIPLINE CODE:

FOR NOTES AND LEGENDS SEE DRAWING 320835.

COMPUTER GENERATED DRAWING NOT TO BE HAND REVISED

320861-00

00-298073

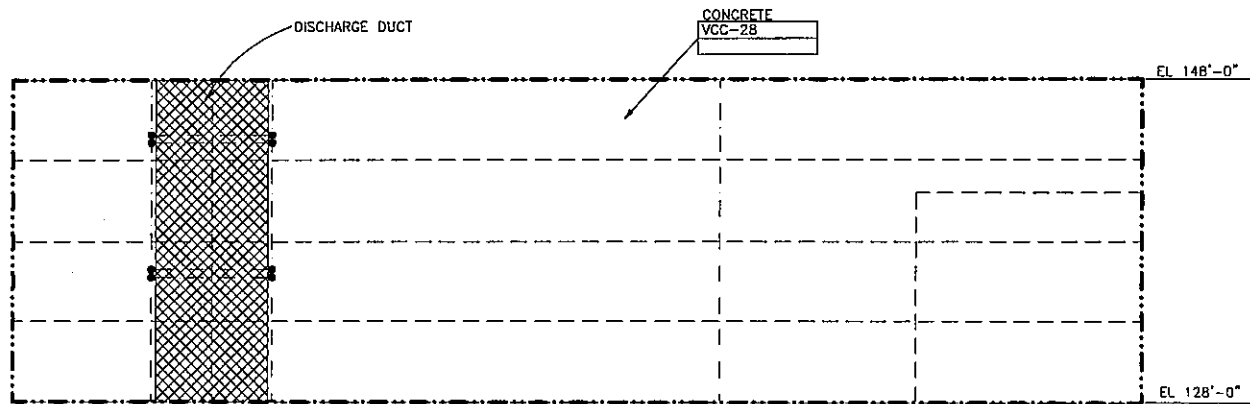

CONCRETE INSPECTION ZONE IWL-128-005
 (EXTERIOR DEVELOPED VIEW, LOOKING FROM OUTSIDE)

REVISION
 USE .1 SIZE TEXT ONLY

REVISION SIGNATURES	
REV	PROJECT ENGINEER
00	

DWG. NO.	320862-00	
CON EDISON	DWG. TYPE	COMPANY
	DWG. SIZE	D
LOCATION:	INDIAN POINT UNIT 2	
TITLE:	CONTAINMENT ISI	
	CONCRETE INSPECTION ZONE	
	IWL-128-05	
	- APPROVALS -	
ENGINEERING MANAGER:		
PROJECT ENGINEER:		
DESIGNER:		
DRAWN BY:	P. CHAU	
SCALE:	NONE	DISCIPLINE CODE:

FOR NOTES AND LEGENDS SEE DRAWING 320835.

COMPUTER GENERATED DRAWING NOT TO BE HAND REVISED

320862-00

320863-00

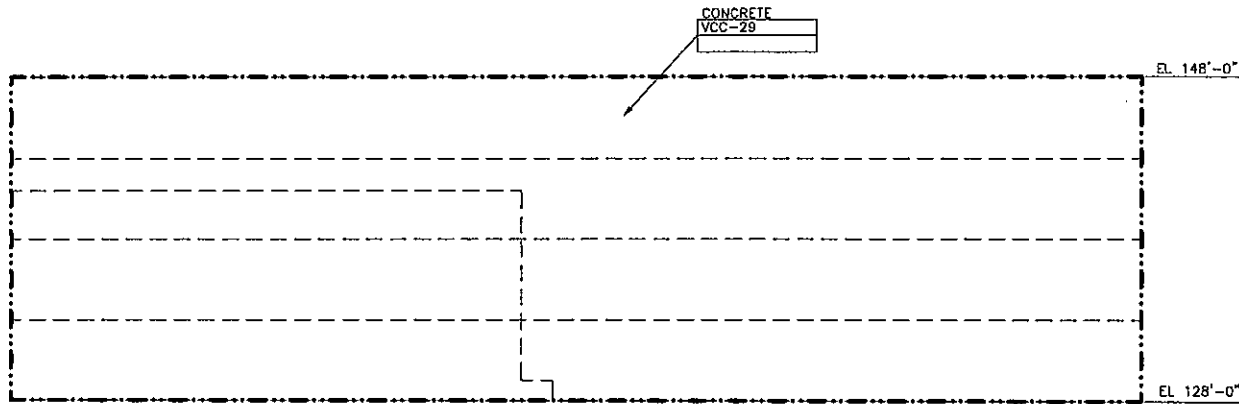

CONCRETE INSPECTION ZONE ML-128-006
 (EXTERIOR DEVELOPED VIEW, LOOKING FROM OUTSIDE)

REVISION USE .1 SIZE TEXT ONLY	
REVISION SIGNATURES	
REV	PROJECT ENGINEER
00	

DWG. NO.	320863-00	
	DWG. TYPE	COMPANY
	DWG. SIZE	D
LOCATION:	INDIAN POINT UNIT 2	
TITLE:	CONTAINMENT ISI	
	CONCRETE INSPECTION ZONE	
	IWL-128-06	
	- APPROVALS -	
ENGINEERING MANAGER:		
PROJECT ENGINEER:		
DESIGNER:		
DRAWN BY:	P. CHAU	
SCALE:	NONE	DISCIPLINE CODE:

320863-00

320864-00

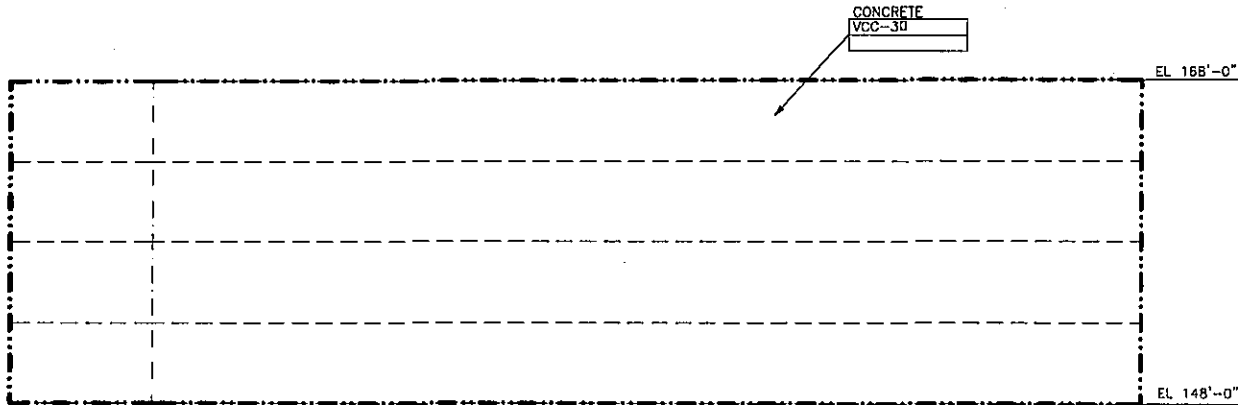

CONCRETE INSPECTION ZONE IWL-148-001
 (EXTERIOR DEVELOPED VIEW, LOOKING FROM OUTSIDE)

FOR NOTES AND LEGENDS SEE DRAWING 320835.

COMPUTER GENERATED DRAWING NOT TO BE HAND REVISED

REVISION
 USE .1 SIZE TEXT ONLY

REVISION
 SIGNATURES

REV PROJECT ENGINEER

00

DWG.
 NO.

320864-00

CON
 EDISON

DWG.
 TYPE COMPANY
 DWG.
 SIZE D

LOCATION: INDIAN POINT UNIT 2

TITLE: CONTAINMENT ISI

CONCRETE INSPECTION ZONE

IWL-148-001

- APPROVALS -

ENGINEERING
 MANAGER:

PROJECT
 ENGINEER:

DESIGNER:

DRAWN
 BY: P. CHAU

SCALE: NONE

DISCIPLINE
 CODE:

320864-00

320865-00

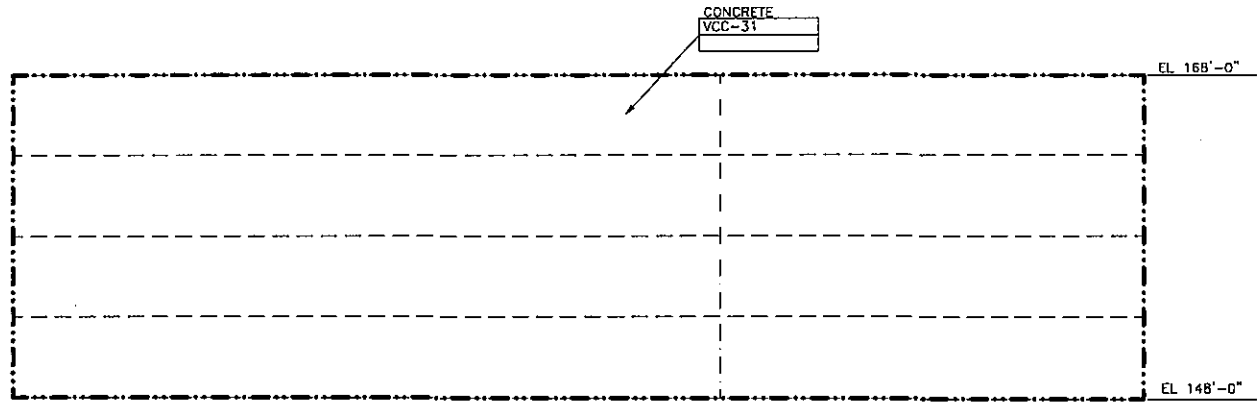

CONCRETE INSPECTION ZONE IWL-148-002
 (EXTERIOR DEVELOPED VIEW, LOOKING FROM OUTSIDE)

REVISION	
USE .1 SIZE TEXT ONLY	
REVISION SIGNATURES	
REV	PROJECT ENGINEER
00	

DWG. NO.	320865-00	
CON EDISON	DWG. TYPE	COMPANY
	DWG. SIZE	D
LOCATION:	INDIAN POINT UNIT 2	
TITLE:	CONTAINMENT ISI	
	CONCRETE INSPECTION ZONE	
	IWL-148-002	
	- APPROVALS -	
ENGINEERING MANAGER:		
PROJECT ENGINEER:		
DESIGNER:		
DRAWN BY:	P. CHAU	
SCALE:	NONE	DISCIPLINE CODE:

FOR NOTES AND LEGENDS SEE DRAWING 320835.

COMPUTER GENERATED DRAWING NOT TO BE HAND REVISED

320865-00

320866-00

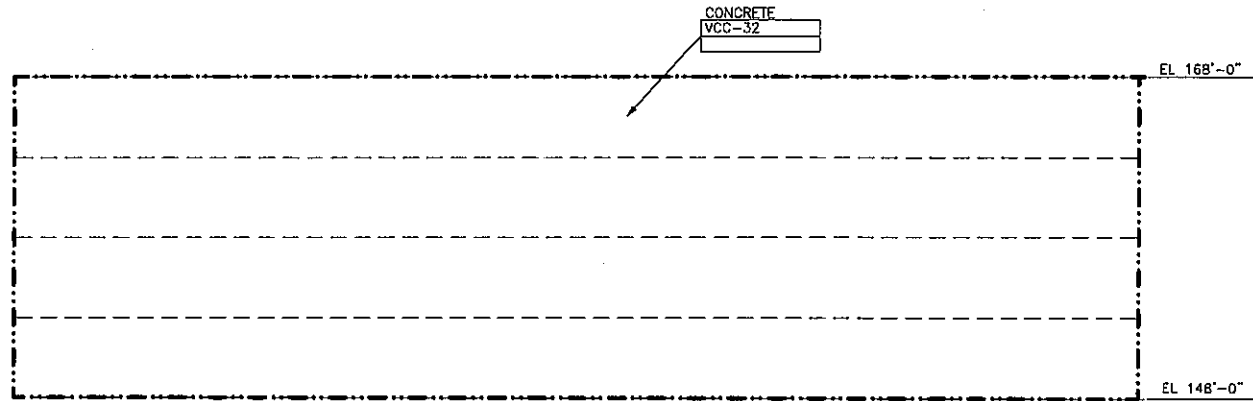

CONCRETE INSPECTION ZONE IWL-148-003
 (EXTERIOR DEVELOPED VIEW, LOOKING FROM OUTSIDE)

REVISION USE .1 SIZE TEXT ONLY	
REVISION SIGNATURES	
REV	PROJECT ENGINEER
00	

DWG. NO.	320866-00	
CON EDISON	DWG. TYPE	COMPANY
	DWG. SIZE	D
LOCATION:	INDIAN POINT UNIT 2	
TITLE:	CONTAINMENT ISI	
	CONCRETE INSPECTION ZONE	
	IWL-148-003	
	- APPROVALS -	
ENGINEERING MANAGER:		
PROJECT ENGINEER:		
DESIGNER:		
DRAWN BY:	P. CHAU	
SCALE:	NONE	DISCIPLINE CODE:

FOR NOTES AND LEGENDS SEE DRAWING 320835.

COMPUTER GENERATED DRAWING NOT TO BE HAND REVISED

320866-00

00-798073

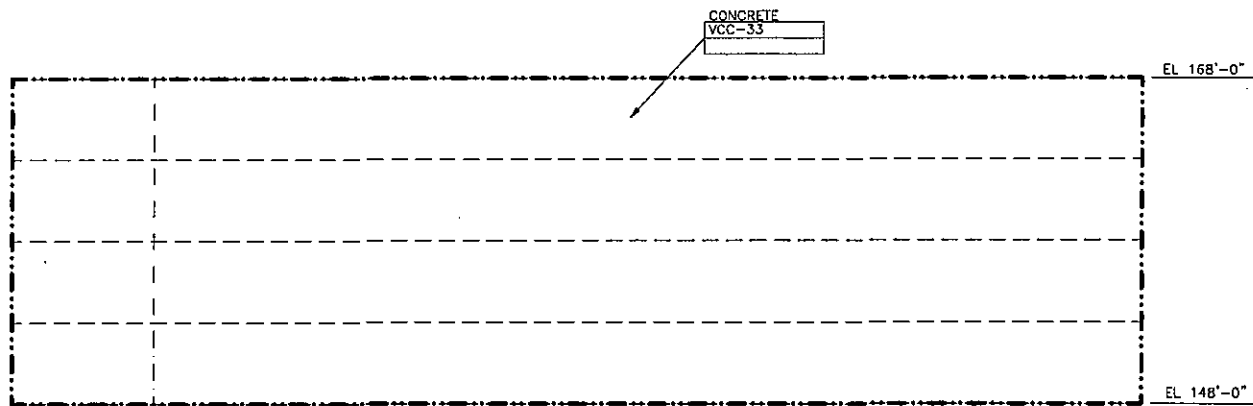

CONCRETE INSPECTION ZONE IW-148-004
 (EXTERIOR DEVELOPED VIEW, LOOKING FROM OUTSIDE)

REVISION
 USE .1 SIZE TEXT ONLY

REVISION SIGNATURES	
REV	PROJECT ENGINEER
00	

DWG. NO. **320867-00**

CON EDISON DWG. TYPE COMPANY
 DWG. SIZE D

LOCATION: **INDIAN POINT UNIT 2**

TITLE: **CONTAINMENT ISI
 CONCRETE INSPECTION ZONE
 IW-148-004
 - APPROVALS -**

ENGINEERING MANAGER:

PROJECT ENGINEER:

DESIGNER:

DRAWN BY: **P. CHAU**

SCALE: **NONE** DISCIPLINE CODE:

FOR NOTES AND LEGENDS SEE DRAWING 320835.

COMPUTER GENERATED DRAWING NOT TO BE HAND REVISED

320867-00

320868-00

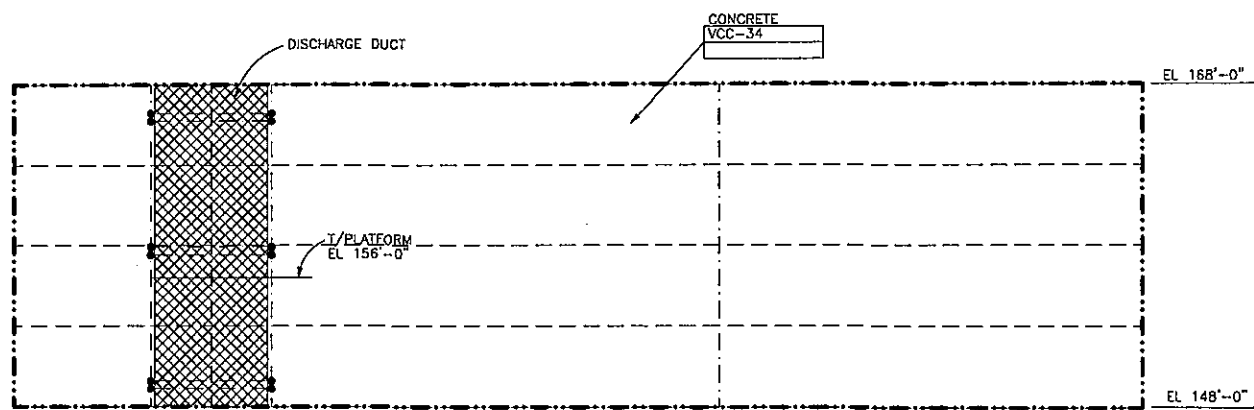

CONCRETE INSPECTION ZONE IWL-148-005
 (EXTERIOR DEVELOPED VIEW, LOOKING FROM OUTSIDE)

FOR NOTES AND LEGENDS SEE DRAWING 320835.

COMPUTER GENERATED DRAWING NOT TO BE HAND REVISED

REVISION USE .1 SIZE TEXT ONLY	
REVISION SIGNATURES	
REV	PROJECT ENGINEER
00	

DWG. NO.	320868-00	
CON EDISON	DWG. TYPE	COMPANY
	DWG. SIZE	D
LOCATION: INDIAN POINT UNIT 2		
TITLE: CONTAINMENT ISI		
CONCRETE INSPECTION ZONE		
IWL-148-005		
- APPROVALS -		
ENGINEERING MANAGER:		
PROJECT ENGINEER:		
DESIGNER:		
DRAWN BY:	P. CHAU	
SCALE:	NONE	DISCIPLINE CODE:

320868-00

00-698073

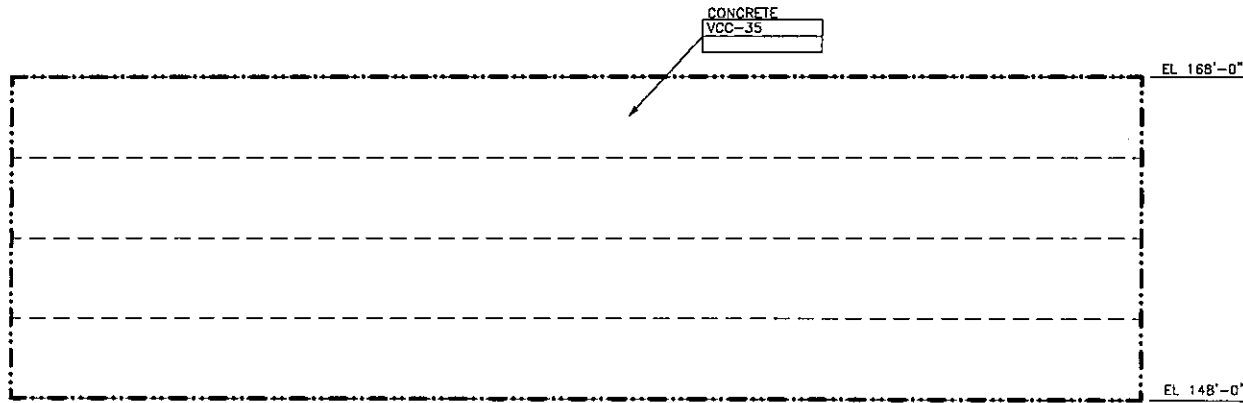

CONCRETE INSPECTION ZONE IWL-148-006
 (EXTERIOR DEVELOPED VIEW, LOOKING FROM OUTSIDE)

REVISION
 USE .1 SIZE TEXT ONLY

REVISION SIGNATURES	
REV	PROJECT ENGINEER
00	

DWG. NO. **320869-00**

CON EDISON DWG. TYPE COMPANY
 DWG. SIZE D

LOCATION: INDIAN POINT UNIT 2

TITLE: CONTAINMENT ISI

CONCRETE INSPECTION ZONE

IWL-148-006

-- APPROVALS --

ENGINEERING MANAGER:

PROJECT ENGINEER:

DESIGNER:

DRAWN BY: P. CHAU

SCALE: NONE DISCIPLINE CODE:

FOR NOTES AND LEGENDS SEE DRAWING 320835.

COMPUTER GENERATED DRAWING NOT TO BE HAND REVISED

320869-00

320870-00

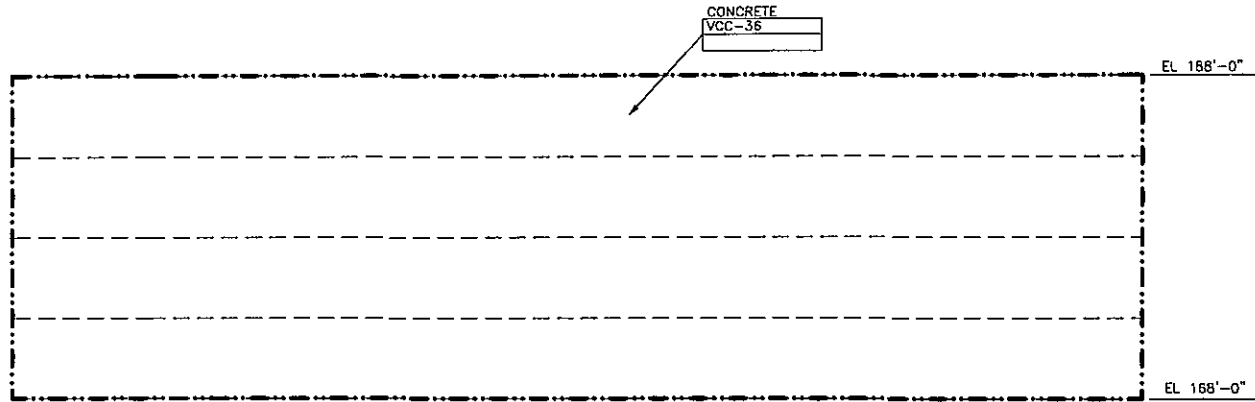

CONCRETE INSPECTION ZONE IWL-168-001
 (EXTERIOR DEVELOPED VIEW, LOOKING FROM OUTSIDE)

REVISION
 USE .1 SIZE TEXT ONLY

REVISION SIGNATURES	
REV	PROJECT ENGINEER
00	

DWG. NO.

320870-00

CON EDISON

DWG. TYPE COMPANY

DWG. SIZE D

LOCATION: INDIAN POINT UNIT 2

TITLE: CONTAINMENT ISI
 CONCRETE INSPECTION ZONE
 IWL-168-001
 - APPROVALS -

ENGINEERING MANAGER:

PROJECT ENGINEER:

DESIGNER:

DRAWN BY: P. CHAU

SCALE: NONE

DISCIPLINE CODE:

FOR NOTES AND LEGENDS SEE DRAWING 320835.

COMPUTER GENERATED DRAWING NOT TO BE HAND REVISED

320870-00

320871-00

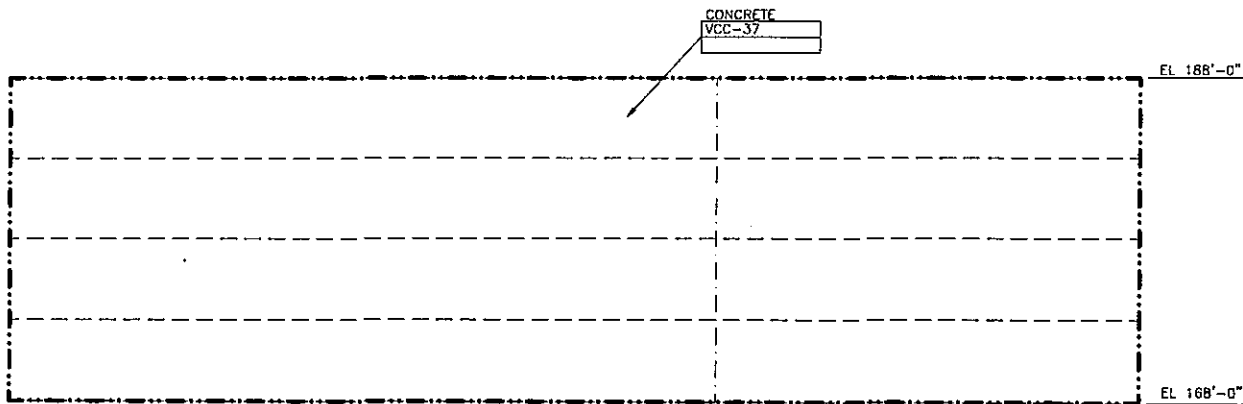

CONCRETE INSPECTION ZONE IWL-168-002
 (EXTERIOR DEVELOPED VIEW, LOOKING FROM OUTSIDE)

REVISION USE .1 SIZE TEXT ONLY	
REVISION SIGNATURES	
REV	PROJECT ENGINEER
00	

DWG. NO.	320871-00	
CON EDISON	DWG. TYPE	COMPANY
	DWG. SIZE	D
LOCATION: INDIAN POINT UNIT 2		
TITLE: CONTAINMENT ISI		
CONCRETE INSPECTION ZONE		
IWL-168-002		
- APPROVALS -		
ENGINEERING MANAGER:		
PROJECT ENGINEER:		
DESIGNER:		
DRAWN BY: P. CHAU		
SCALE:	NONE	DISCIPLINE CODE:

FOR NOTES AND LEGENDS SEE DRAWING 320835.

COMPUTER GENERATED DRAWING NOT TO BE HAND REVISED

320871-00

320872-00

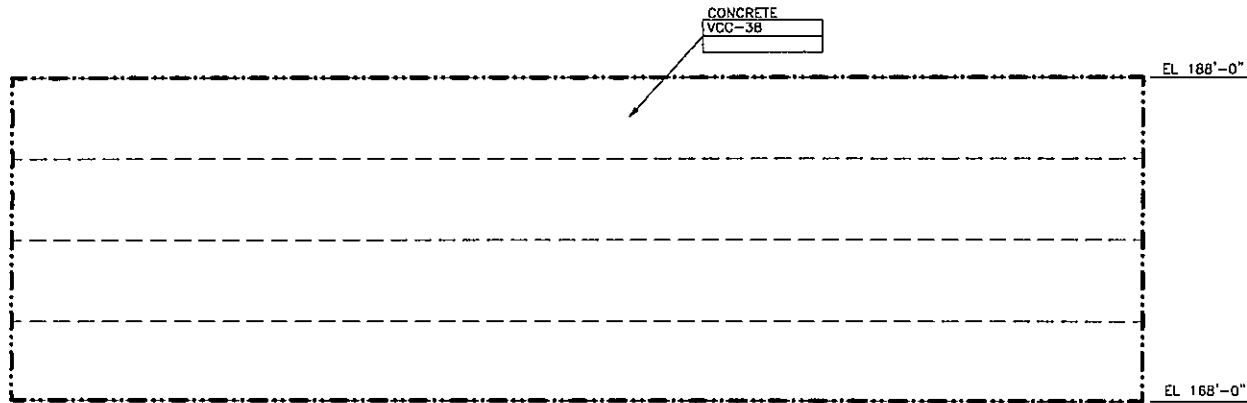

CONCRETE INSPECTION ZONE IWL-168-003
 (EXTERIOR DEVELOPED VIEW, LOOKING FROM OUTSIDE)

REVISION
 USE .1 SIZE TEXT ONLY

REVISION SIGNATURES	
REV	PROJECT ENGINEER
00	

DWG. NO.	320872-00	
DWG. TYPE	CON EDISON COMPANY	
DWG. SIZE	D	
LOCATION:	INDIAN POINT UNIT 2	
TITLE:	CONTAINMENT ISI	
	CONCRETE INSPECTION ZONE	
	IWL-168-003	
	- APPROVALS -	
ENGINEERING MANAGER:		
PROJECT ENGINEER:		
DESIGNER:		
DRAWN BY:	P. CHAU	
SCALE:	NONE	DISCIPLINE CODE:

FOR NOTES AND LEGENDS SEE DRAWING 320835.

COMPUTER GENERATED DRAWING NOT TO BE HAND REVISED

320872-00

320873-00

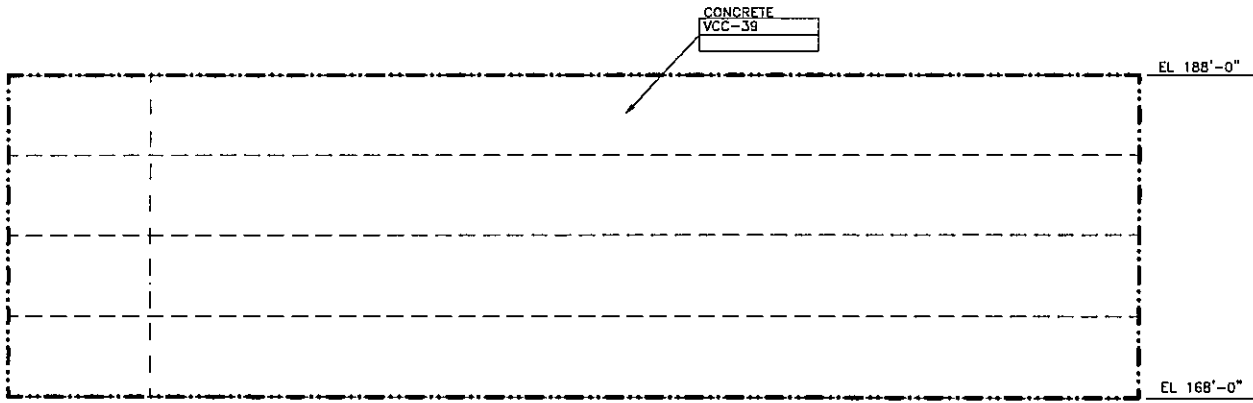

CONCRETE INSPECTION ZONE IWL-168-004
 (EXTERIOR DEVELOPED VIEW, LOOKING FROM OUTSIDE)

REVISION
 USE .1 SIZE TEXT ONLY

REVISION SIGNATURES	
REV	PROJECT ENGINEER
00	

DWG. NO.	320873-00	
	CON EDISON	DWG. TYPE COMPANY D
LOCATION:	INDIAN POINT UNIT 2	
TITLE:	CONTAINMENT ISI CONCRETE INSPECTION ZONE IWL-168-004 - APPROVALS -	
ENGINEERING MANAGER:		
PROJECT ENGINEER:		
DESIGNER:		
DRAWN BY:	P. CHAU	
SCALE:	NONE	DISCIPLINE CODE:

FOR NOTES AND LEGENDS SEE DRAWING 320835.

COMPUTER GENERATED DRAWING NOT TO BE HAND REVISED

320873-00

320874-00

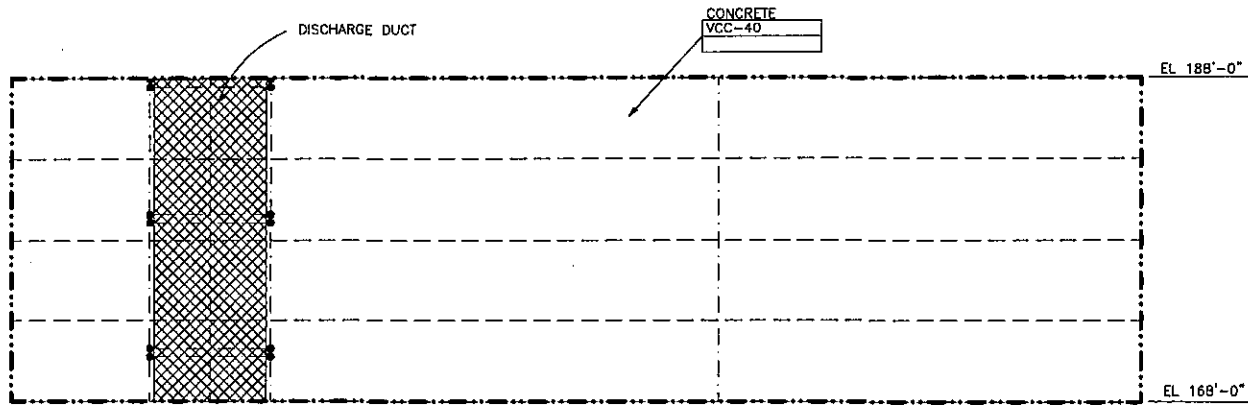

CONCRETE INSPECTION ZONE IWL-168-005
 (EXTERIOR DEVELOPED VIEW, LOOKING FROM OUTSIDE)

REVISION USE .1 SIZE TEXT ONLY	
REVISION SIGNATURES	
REV	PROJECT ENGINEER
00	

DWG. NO.	320874-00	
CON EDISON	DWG. TYPE	COMPANY
	DWG. SIZE	D
LOCATION: INDIAN POINT UNIT 2		
TITLE: CONTAINMENT ISI		
CONCRETE INSPECTION ZONE		
IWL-168-005		
- APPROVALS -		
ENGINEERING MANAGER:		
PROJECT ENGINEER:		
DESIGNER:		
DRAWN BY:	P. CHAU	
SCALE:	NONE	DISCIPLINE CODE:

FOR NOTES AND LEGENDS SEE DRAWING 320835.

COMPUTER GENERATED DRAWING NOT TO BE HAND REVISED

320874-00

320875-00

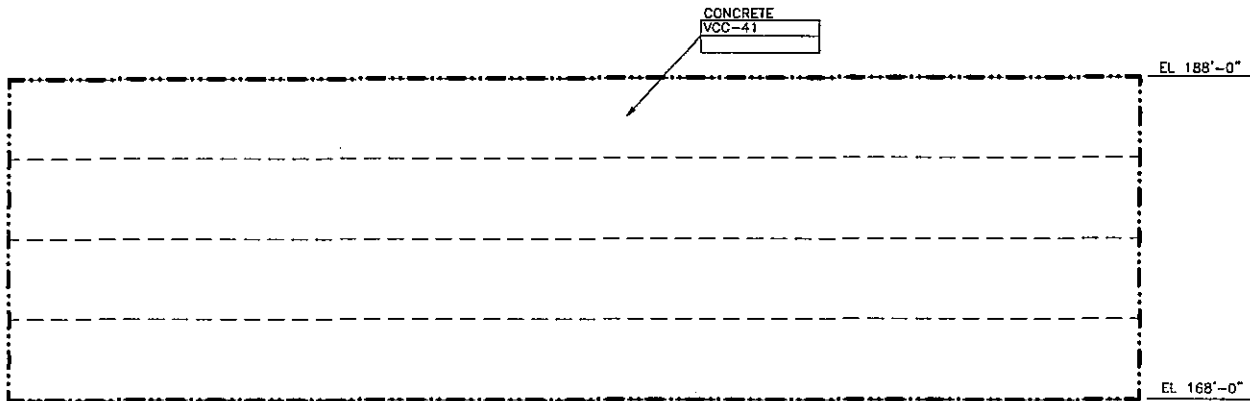

CONCRETE INSPECTION ZONE IWL-168-006
 (EXTERIOR DEVELOPED VIEW, LOOKING FROM OUTSIDE)

REVISION
 USE .1 SIZE TEXT ONLY

REVISION SIGNATURES	
REV	PROJECT ENGINEER
00	

DWG. NO. **320875-00**

CON EDISON DWG. TYPE COMPANY
 DWG. SIZE D

LOCATION: **INDIAN POINT UNIT 2**

TITLE: **CONTAINMENT ISI**
CONCRETE INSPECTION ZONE
IWL-168-006
- APPROVALS -

ENGINEERING MANAGER:

PROJECT ENGINEER:

DESIGNER:

DRAWN BY: **P. CHAU**

SCALE: **NONE** DISCIPLINE CODE:

FOR NOTES AND LEGENDS SEE DRAWING 320835.

COMPUTER GENERATED DRAWING NOT TO BE HAND REVISED

320875-00

320876-00

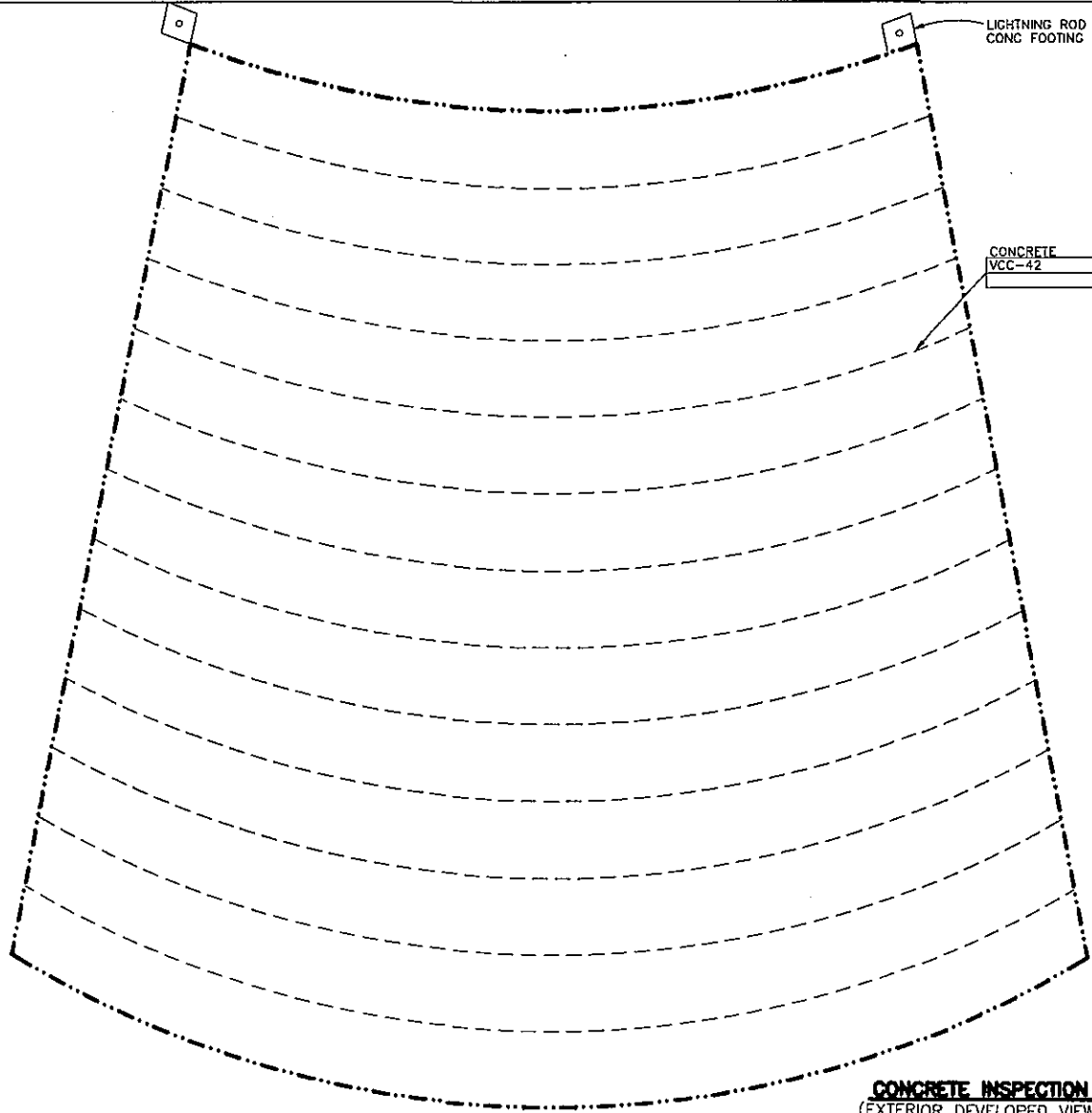

LIGHTNING ROD
CONC FOOTING

CONCRETE
VCC-42

REVISION USE .1 SIZE TEXT ONLY	
REVISION SIGNATURES	
REV	PROJECT ENGINEER
00	

DWG. NO.	320876-00	
CON EDISON	DWG. TYPE	COMPANY
	DWG. SIZE	D
LOCATION: INDIAN POINT UNIT 2		
TITLE: CONTAINMENT ISI		
CONCRETE INSPECTION ZONE		
IWL-DOME-001		
- APPROVALS -		
ENGINEERING MANAGER:		
PROJECT ENGINEER:		
DESIGNER:		
DRAWN BY:	P. CHAU	
SCALE:	NONE	DISCIPLINE CODE:

CONCRETE INSPECTION ZONE IWL-DOME-001
(EXTERIOR DEVELOPED VIEW, LOOKING FROM OUTSIDE)

FOR NOTES AND LEGENDS SEE DRAWING 320835.

COMPUTER GENERATED DRAWING NOT TO BE HAND REVISED

320876-00

REVISION USE .1 SIZE TEXT ONLY	
REVISION SIGNATURES	
REV	PROJECT ENGINEER
00	
DWG. NO.	320877-00
DWG. TYPE	CON COMPANY
DWG. SIZE	EDISON D
LOCATION: INDIAN POINT UNIT 2	
TITLE:	CONTAINMENT ISI
	CONCRETE INSPECTION ZONE
	IWL-DOME-002
	- APPROVALS -
ENGINEERING MANAGER:	
PROJECT ENGINEER:	
DESIGNER:	
DRAWN BY:	P. CHAU
SCALE:	NONE
	DISCIPLINE CODE:

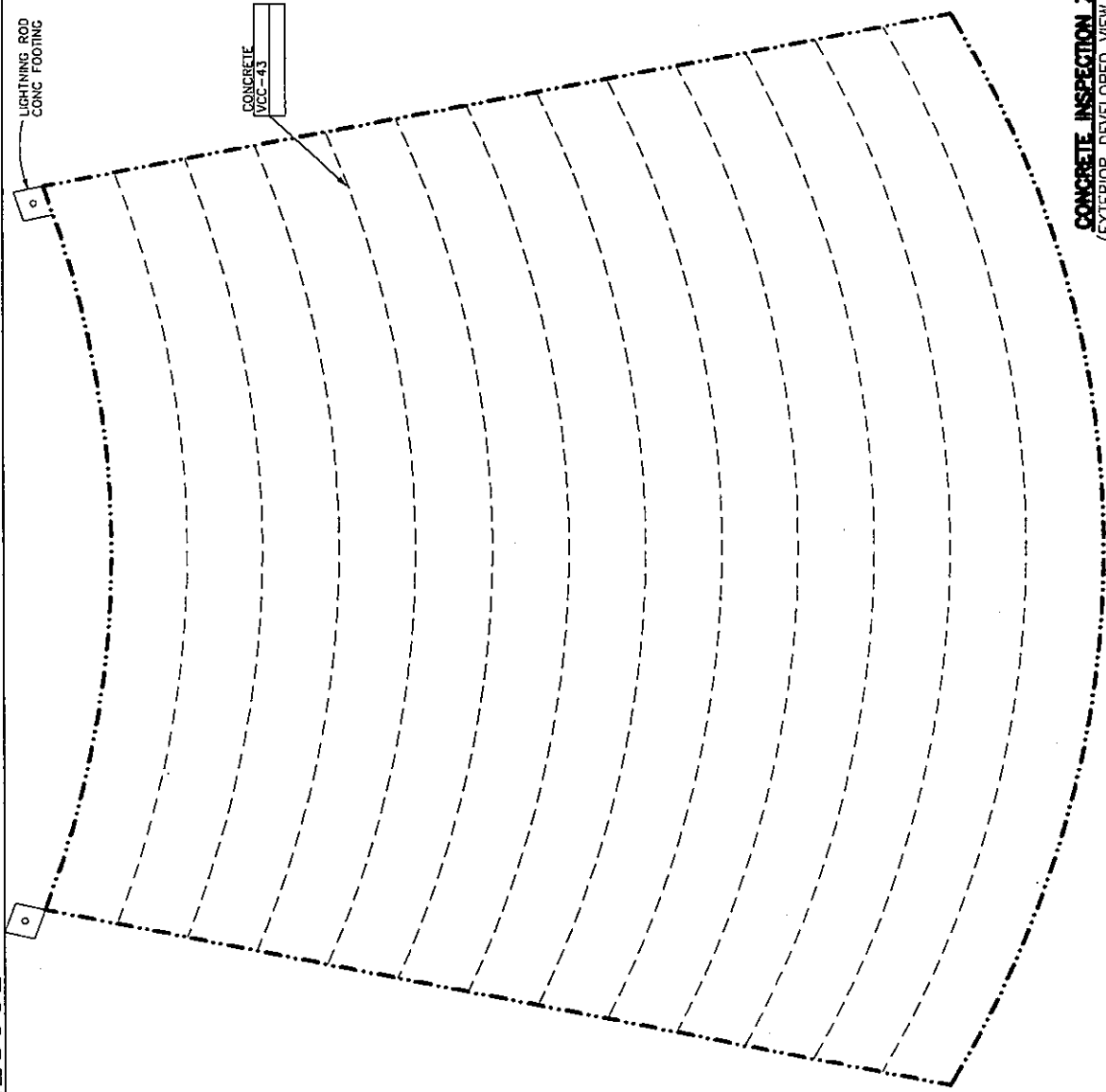

320877-00

CONCRETE INSPECTION ZONE IWL-DOME-002
(EXTERIOR DEVELOPED VIEW, LOOKING FROM OUTSIDE)

FOR NOTES AND LEGENDS SEE DRAWING 320835.

COMPUTER GENERATED DRAWING NOT TO BE HAND REVISED

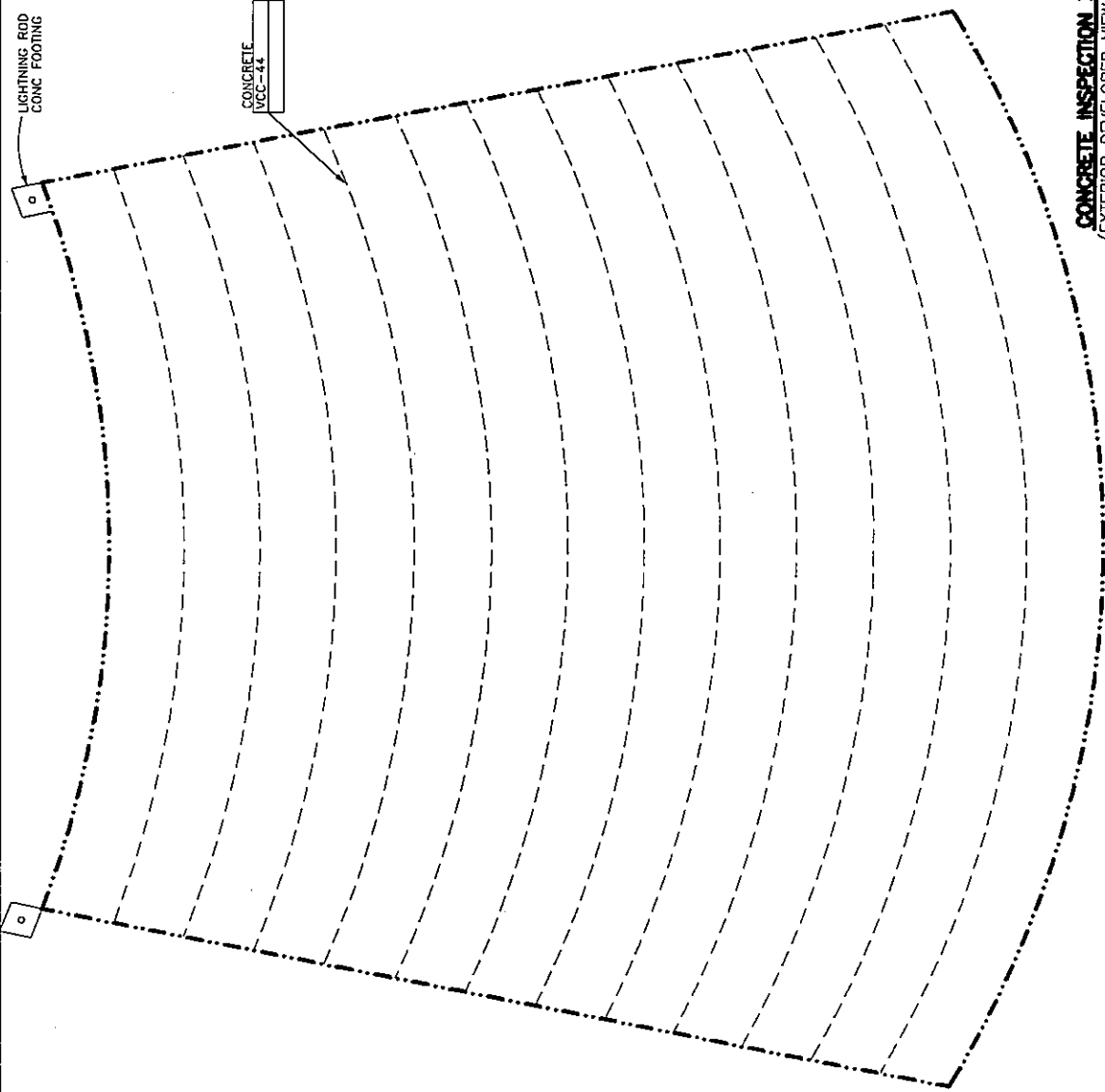

REVISION		USE .1 SIZE TEXT ONLY
SIGNATURES		
REV	PROJECT ENGINEER	
		00
DWG. NO.	320878-00	
DWG. TYPE	CON COMPANY	
DWG. SIZE	EDISON D	
LOCATION:	INDIAN POINT UNIT 2	
TITLE:	CONTAINMENT ISI	
	CONCRETE INSPECTION ZONE	
	IWL-DOME-003	
	- APPROVALS -	
ENGINEERING MANAGER:		
PROJECT ENGINEER:		
DESIGNER:		
DRAWN BY:	P. CHAU	
SCALE:	NONE	
DISCIPLINE CODE:		

CONCRETE INSPECTION ZONE IWL-DOME-003
 (EXTERIOR DEVELOPED VIEW, LOOKING FROM OUTSIDE)

FOR NOTES AND LEGENDS SEE DRAWING 320835.

COMPUTER GENERATED DRAWING NOT TO BE HAND REVISED

REVISION USE .1 SIZE TEXT ONLY	
REVISION SIGNATURES	
REV	PROJECT ENGINEER
00	

DWG. NO.	320879-00
DWG. TYPE	CON COMPANY
DWG. SIZE	D
LOCATION:	INDIAN POINT UNIT 2
TITLE:	CONTAINMENT ISI
	CONCRETE INSPECTION ZONE
	IWL-DOME-004
	- APPROVALS -
ENGINEERING MANAGER:	
PROJECT ENGINEER:	
DESIGNER:	
DRAWN BY:	P. CHAU
SCALE:	NONE
DISCIPLINE CODE:	

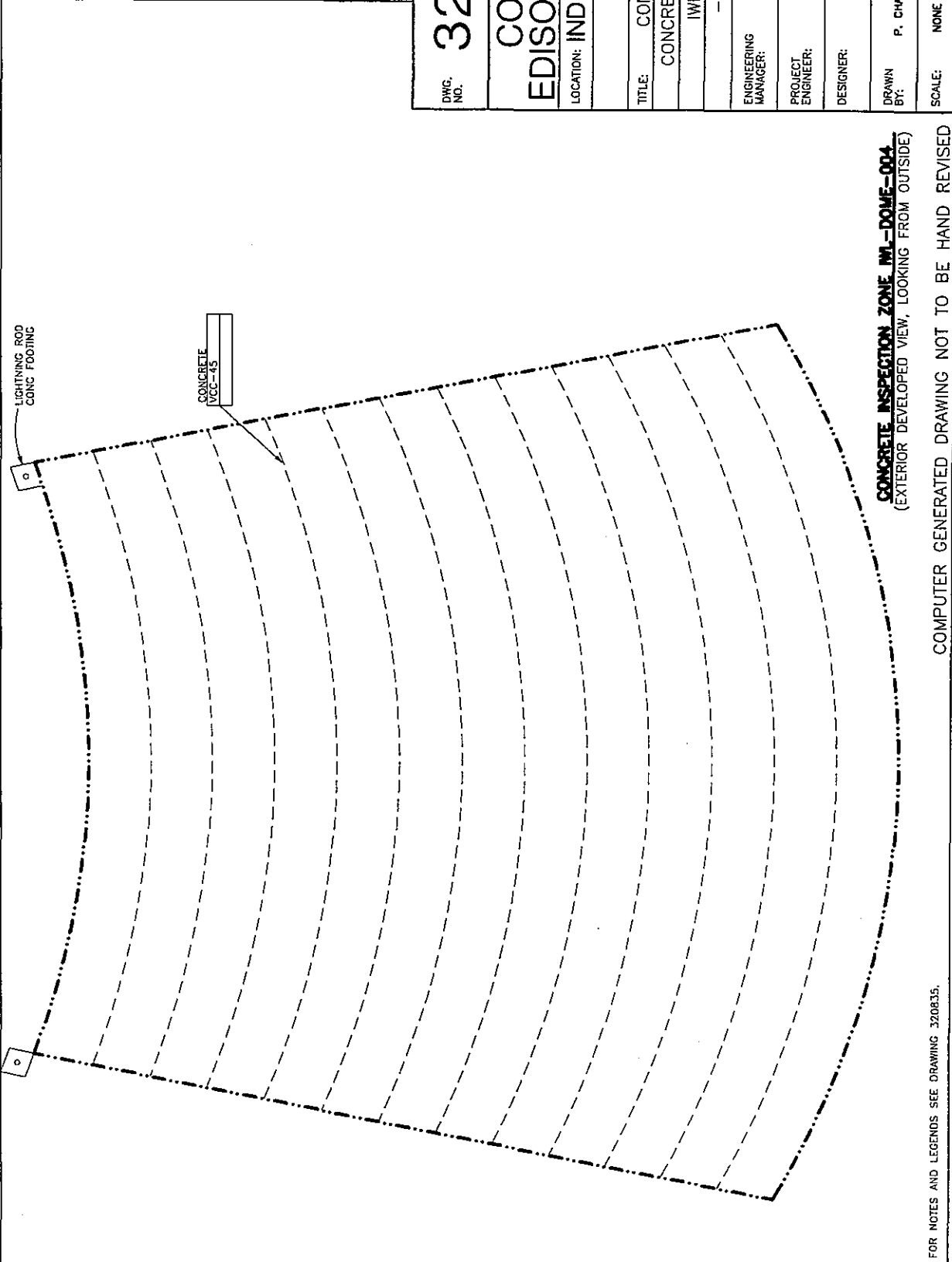

CONCRETE INSPECTION ZONE IWL-DOME-004
(EXTERIOR DEVELOPED VIEW, LOOKING FROM OUTSIDE)

FOR NOTES AND LEGENDS SEE DRAWING 320835. COMPUTER GENERATED DRAWING NOT TO BE HAND REVISED

REVISION USE .1 SIZE TEXT ONLY	
REVISION SIGNATURES	
REV	PROJECT ENGINEER
00	
DWG. NO. 320880-00	
DWG. TYPE	COMPANY
CON	EDISON
DWG. SIZE	
D	
LOCATION: INDIAN POINT UNIT 2	
TITLE: CONTAINMENT ISI	
CONCRETE INSPECTION ZONE	
IML-DOME-005	
- APPROVALS -	
ENGINEERING MANAGER:	
PROJECT ENGINEER:	
DESIGNER:	
DRAWN BY:	P. CHAU
SCALE:	NONE
DISCIPLINE CODE:	

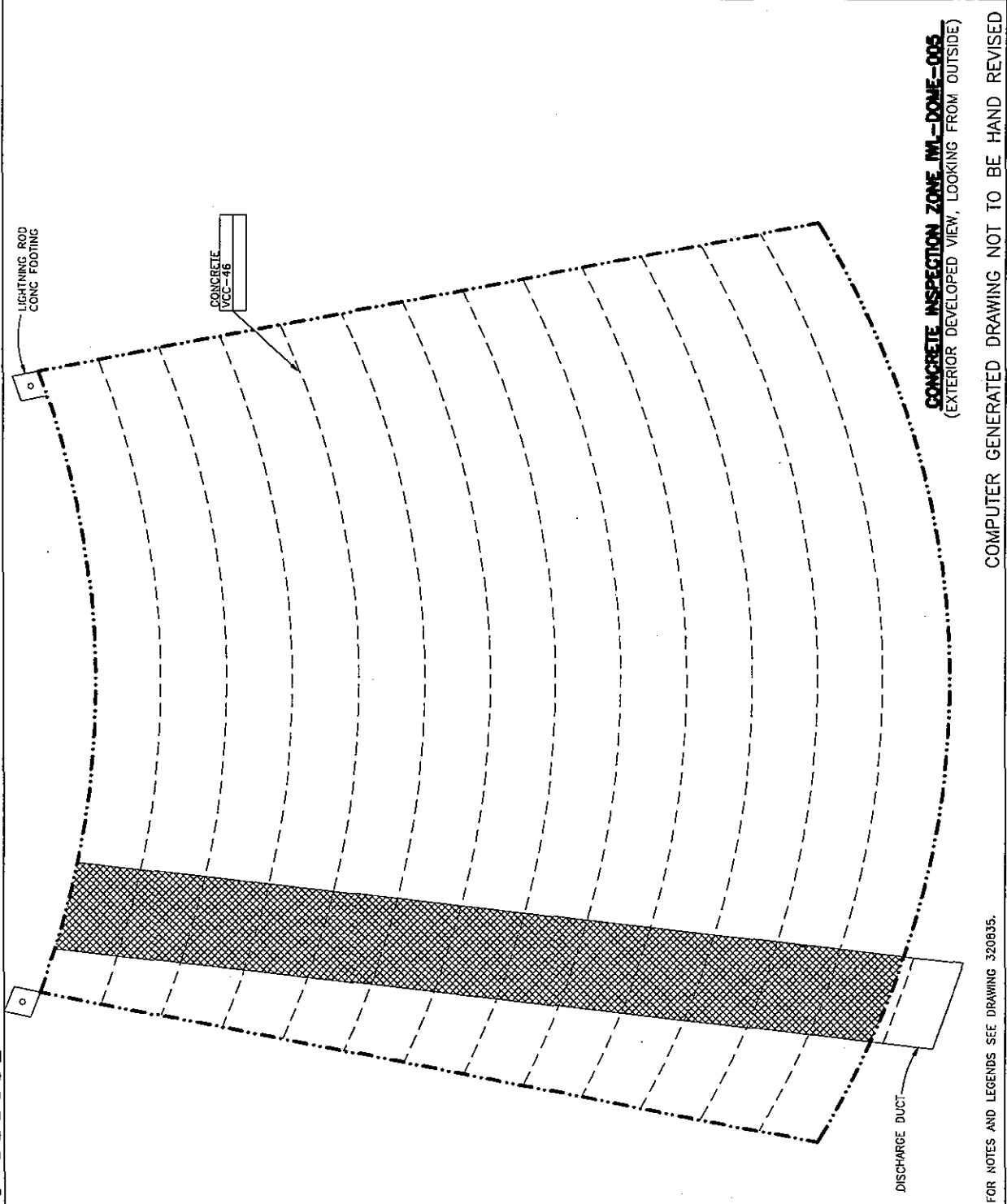

320880-00

CONCRETE INSPECTION ZONE IML-DOME-005
(EXTERIOR DEVELOPED VIEW, LOOKING FROM OUTSIDE)

COMPUTER GENERATED DRAWING NOT TO BE HAND REVISED

FOR NOTES AND LEGENDS SEE DRAWING 320835.

320881-00

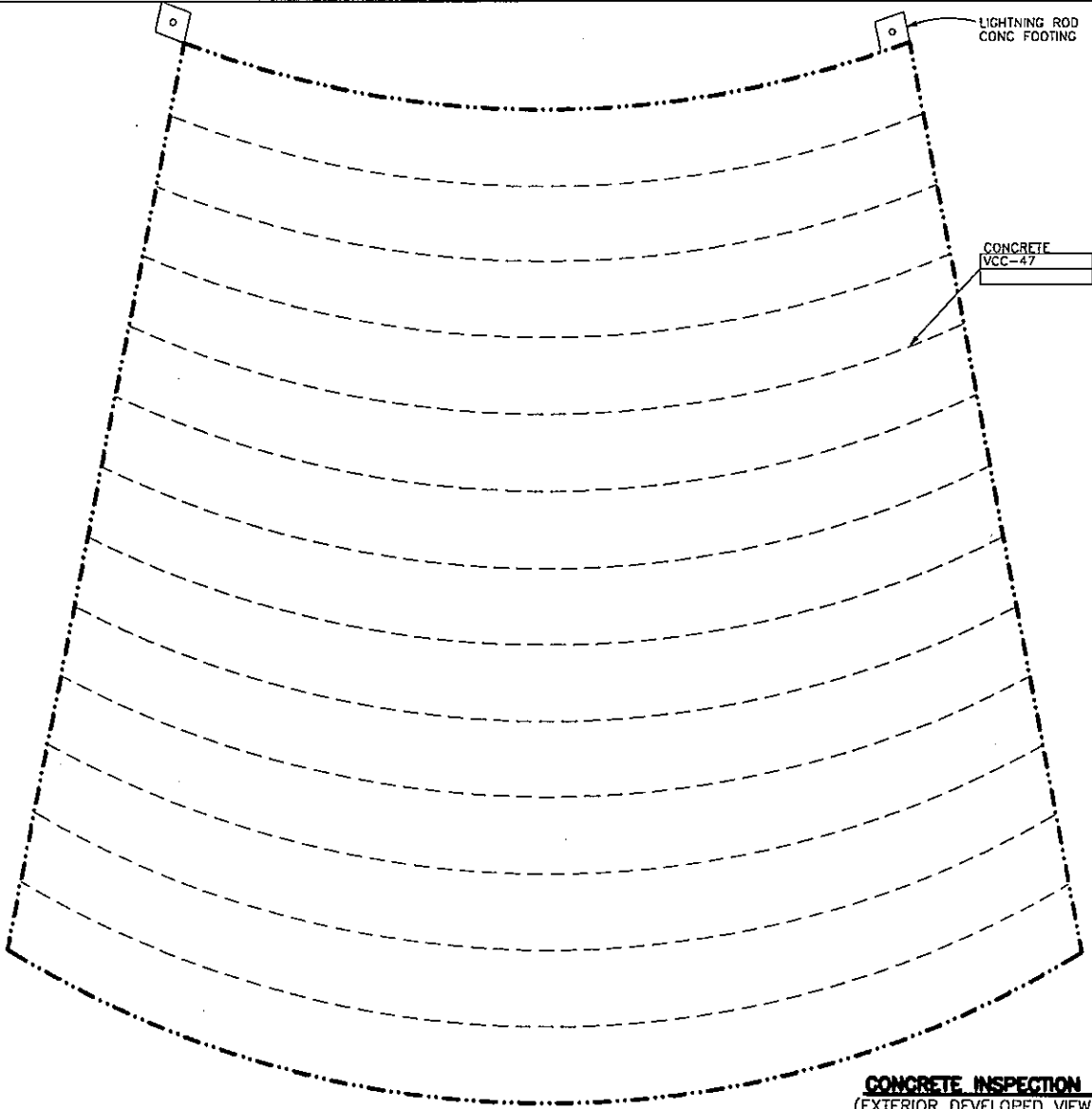

REVISION	
USE .1 SIZE TEXT ONLY	
REVISION SIGNATURES	
REV	PROJECT ENGINEER
00	

DWG. NO.	320881-00	
CON EDISON	DWG. TYPE	COMPANY
	DWG. SIZE	D
LOCATION:	INDIAN POINT UNIT 2	
TITLE:	CONTAINMENT ISI	
	CONCRETE INSPECTION ZONE	
	IWL-DOME-006	
	- APPROVALS -	
ENGINEERING MANAGER:		
PROJECT ENGINEER:		
DESIGNER:		
DRAWN BY:	P. CHAU	
SCALE:	NONE	DISCIPLINE CODE:

CONCRETE INSPECTION ZONE IWL-DOME-006
 (EXTERIOR DEVELOPED VIEW, LOOKING FROM OUTSIDE)

FOR NOTES AND LEGENDS SEE DRAWING 320835.

COMPUTER GENERATED DRAWING NOT TO BE HAND REVISED

320881-00

00-288023

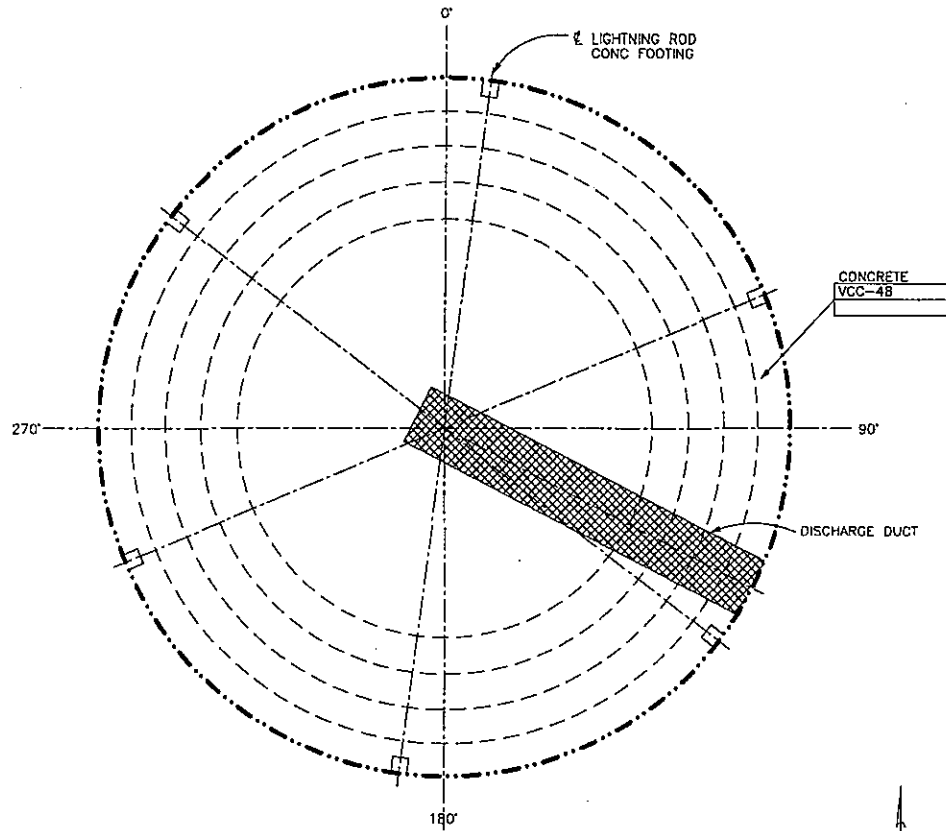

CONCRETE INSPECTION ZONE IWL-DOME-007
(EXTERIOR DEVELOPED VIEW, LOOKING FROM OUTSIDE)

FOR NOTES AND LEGENDS SEE DRAWING 320835.

COMPUTER GENERATED DRAWING NOT TO BE HAND REVISED

REVISION
USE .1 SIZE TEXT ONLY

REVISION
SIGNATURES

REV	PROJECT ENGINEER
00	

DWG. NO. **320882-00**

CON EDISON DWG. TYPE COMPANY
DWG. SIZE D

LOCATION: **INDIAN POINT UNIT 2**

TITLE: **CONTAINMENT ISI**
CONCRETE INSPECTION ZONE
IWL-DOME-007
- APPROVALS -

ENGINEERING
MANAGER:

PROJECT
ENGINEER:

DESIGNER:

DRAWN
BY: **P. CHAU**

SCALE: **NONE**

DISCIPLINE
CODE:

320882-00

B



**INDIAN POINT UNIT 2
CONTAINMENT INSERVICE INSPECTION
FIRST PERIOD EXAMINATIONS**



**Category L-A, Concrete Examinations
Tab B - Listing of Scheduled Exams**

CATEGORY L-A

IWL COMPONENTS SCHEDULED BY OUTAGE

Containment Inservice Inspection Program
First Containment Inspection Interval

Outage 2000RFO

Component	Component Type Description	Detail Drawing	Cat.	Item	Exam Scheduled	Outage	Relief Request	Inspect From Inside/Outside	
VCC-02	Concrete Containment Wall		L-A	L1.11		2000RFO	RR-45	<input type="checkbox"/>	<input checked="" type="checkbox"/>
VCC-03	Concrete Containment Wall		L-A	L1.11		2000RFO	RR-45	<input type="checkbox"/>	<input checked="" type="checkbox"/>
VCC-04	Concrete Containment Wall		L-A	L1.11		2000RFO	RR-45	<input type="checkbox"/>	<input checked="" type="checkbox"/>
VCC-05	Concrete Containment Wall		L-A	L1.11		2000RFO	RR-45	<input type="checkbox"/>	<input checked="" type="checkbox"/>
VCC-06	Concrete Containment Wall		L-A	L1.11		2000RFO	RR-45	<input type="checkbox"/>	<input checked="" type="checkbox"/>
VCC-07	Concrete Containment Wall		L-A	L1.11		2000RFO	RR-45	<input type="checkbox"/>	<input checked="" type="checkbox"/>
VCC-08	Concrete Containment Wall		L-A	L1.11		2000RFO	RR-45	<input type="checkbox"/>	<input checked="" type="checkbox"/>
VCC-09	Concrete Containment Wall		L-A	L1.11		2000RFO	RR-45	<input type="checkbox"/>	<input checked="" type="checkbox"/>
VCC-10	Concrete Containment Wall		L-A	L1.11		2000RFO	RR-45	<input type="checkbox"/>	<input checked="" type="checkbox"/>
VCC-11	Concrete Containment Wall		L-A	L1.11		2000RFO	RR-45	<input type="checkbox"/>	<input checked="" type="checkbox"/>
VCC-12	Concrete Containment Wall		L-A	L1.11		2000RFO	RR-45	<input type="checkbox"/>	<input checked="" type="checkbox"/>
VCC-13	Concrete Containment Wall		L-A	L1.11		2000RFO	RR-45	<input type="checkbox"/>	<input checked="" type="checkbox"/>
VCC-14	Concrete Containment Wall		L-A	L1.11		2000RFO	RR-45	<input type="checkbox"/>	<input checked="" type="checkbox"/>
VCC-15	Concrete Containment Wall		L-A	L1.11		2000RFO	RR-45	<input type="checkbox"/>	<input checked="" type="checkbox"/>

CATEGORY L-A

IWL COMPONENTS SCHEDULED BY OUTAGE

Containment Inservice Inspection Program
 First Containment Inspection Interval
 Outage 2000RFO

Component	Component Type Description	Detail Drawing	Cat.	Item	Exam Scheduled	Outage	Relief Request	Inspect From Inside/Outside
VCC-16	Concrete Containment Wall		L-A	L1.11		2000RFO	RR-45	<input type="checkbox"/> <input checked="" type="checkbox"/>
VCC-17	Concrete Containment Wall		L-A	L1.11		2000RFO	RR-45	<input type="checkbox"/> <input checked="" type="checkbox"/>
VCC-18	Concrete Containment Wall		L-A	L1.11		2000RFO	RR-45	<input type="checkbox"/> <input checked="" type="checkbox"/>
VCC-19	Concrete Containment Wall		L-A	L1.11		2000RFO	RR-45	<input type="checkbox"/> <input checked="" type="checkbox"/>
VCC-20	Concrete Containment Wall		L-A	L1.11		2000RFO	RR-45	<input type="checkbox"/> <input checked="" type="checkbox"/>
VCC-21	Concrete Containment Wall		L-A	L1.11		2000RFO	RR-45	<input type="checkbox"/> <input checked="" type="checkbox"/>
VCC-22	Concrete Containment Wall		L-A	L1.11		2000RFO	RR-45	<input type="checkbox"/> <input checked="" type="checkbox"/>
VCC-23	Concrete Containment Wall		L-A	L1.11		2000RFO	RR-45	<input type="checkbox"/> <input checked="" type="checkbox"/>
VCC-24	Concrete Containment Wall		L-A	L1.11		2000RFO	RR-45	<input type="checkbox"/> <input checked="" type="checkbox"/>
VCC-25	Concrete Containment Wall		L-A	L1.11		2000RFO	RR-45	<input type="checkbox"/> <input checked="" type="checkbox"/>
VCC-26	Concrete Containment Wall		L-A	L1.11		2000RFO	RR-45	<input type="checkbox"/> <input checked="" type="checkbox"/>
VCC-27	Concrete Containment Wall		L-A	L1.11		2000RFO	RR-45	<input type="checkbox"/> <input checked="" type="checkbox"/>
VCC-28	Concrete Containment Wall		L-A	L1.11		2000RFO	RR-45	<input type="checkbox"/> <input checked="" type="checkbox"/>
VCC-29	Concrete Containment Wall		L-A	L1.11		2000RFO	RR-45	<input type="checkbox"/> <input checked="" type="checkbox"/>

CATEGORY L-A

IWL COMPONENTS SCHEDULED BY OUTAGE

Containment Inservice Inspection Program
 First Containment Inspection Interval
 Outage 2000RFO

Component	Component Type Description	Detail Drawing	Cat.	Item	Exam Scheduled	Outage	Relief Request	Inspect From Inside/Outside
VCC-30	Concrete Containment Wall		L-A	L1.11		2000RFO	RR-45	<input type="checkbox"/> <input checked="" type="checkbox"/>
VCC-31	Concrete Containment Wall		L-A	L1.11		2000RFO	RR-45	<input type="checkbox"/> <input checked="" type="checkbox"/>
VCC-32	Concrete Containment Wall		L-A	L1.11		2000RFO	RR-45	<input type="checkbox"/> <input checked="" type="checkbox"/>
VCC-33	Concrete Containment Wall		L-A	L1.11		2000RFO	RR-45	<input type="checkbox"/> <input checked="" type="checkbox"/>
VCC-34	Concrete Containment Wall		L-A	L1.11		2000RFO	RR-45	<input type="checkbox"/> <input checked="" type="checkbox"/>
VCC-35	Concrete Containment Wall		L-A	L1.11		2000RFO	RR-45	<input type="checkbox"/> <input checked="" type="checkbox"/>
VCC-36	Concrete Containment Wall		L-A	L1.11		2000RFO	RR-45	<input type="checkbox"/> <input checked="" type="checkbox"/>
VCC-37	Concrete Containment Wall		L-A	L1.11		2000RFO	RR-45	<input type="checkbox"/> <input checked="" type="checkbox"/>
VCC-38	Concrete Containment Wall		L-A	L1.11		2000RFO	RR-45	<input type="checkbox"/> <input checked="" type="checkbox"/>
VCC-39	Concrete Containment Wall		L-A	L1.11		2000RFO	RR-45	<input type="checkbox"/> <input checked="" type="checkbox"/>
VCC-40	Concrete Containment Wall		L-A	L1.11		2000RFO	RR-45	<input type="checkbox"/> <input checked="" type="checkbox"/>
VCC-41	Concrete Containment Wall		L-A	L1.11		2000RFO	RR-45	<input type="checkbox"/> <input checked="" type="checkbox"/>
VCC-42	Concrete Containment Dome		L-A	L1.11		2000RFO	RR-45	<input type="checkbox"/> <input checked="" type="checkbox"/>
VCC-43	Concrete Containment Dome		L-A	L1.11		2000RFO	RR-45	<input type="checkbox"/> <input checked="" type="checkbox"/>

CATEGORY L-A

IWL COMPONENTS SCHEDULED BY OUTAGE

Containment Inservice Inspection Program
First Containment Inspection Interval

Outage 2000RFO

Component	Component Type Description	Detail Drawing	Cat.	Item	Exam Scheduled	Outage	Relief Request	Inspect From Inside/Outside
VCC-44	Concrete Containment Dome		L-A	L1.11		2000RFO	RR-45	<input type="checkbox"/> <input checked="" type="checkbox"/>
VCC-45	Concrete Containment Dome		L-A	L1.11		2000RFO	RR-45	<input type="checkbox"/> <input checked="" type="checkbox"/>
VCC-46	Concrete Containment Dome		L-A	L1.11		2000RFO	RR-45	<input type="checkbox"/> <input checked="" type="checkbox"/>
VCC-47	Concrete Containment Dome		L-A	L1.11		2000RFO	RR-45	<input type="checkbox"/> <input checked="" type="checkbox"/>
VCC-48	Concrete Containment Dome		L-A	L1.11		2000RFO		<input type="checkbox"/> <input checked="" type="checkbox"/>



**INDIAN POINT UNIT 2
CONTAINMENT INSERVICE INSPECTION
FIRST PERIOD EXAMINATIONS**



**Category L-A, Concrete Examinations
Tab C - Listing of Examination Results**

CATEGORY L-A

IWL EXAMINATION RESULTS

Containment Inservice Inspection Program
First Containment Inspection Interval

Outage Number 2000RFO

Component	Outage Number	Exam	Complete	Limited Exam	Exam Date	Examined By	Zone Number	Work Order Number	Results	Exam Notes
VCC-01	2000RFO	VT-3C	<input checked="" type="checkbox"/>	<input type="checkbox"/>	5/26/00	C. Sward	IWL-034-001	NP-99-11274	RI	Acceptable per RE review
VCC-02	2000RFO	VT-3C	<input checked="" type="checkbox"/>	<input type="checkbox"/>	6/1/00	C. Sward	IWL-034-002	NP-99-11274	NRI	Acceptable per RE review
VCC-03	2000RFO	VT-3C	<input type="checkbox"/>	<input type="checkbox"/>			IWL-034-003	NP-99-11274		Not accessible for examination.
VCC-04	2000RFO	VT-3C	<input checked="" type="checkbox"/>	<input type="checkbox"/>	5/26/00	R. Namperumal	IWL-043-001	NP-99-11274	RI	CRS 200004138
VCC-05	2000RFO	VT-3C	<input checked="" type="checkbox"/>	<input type="checkbox"/>	6/1/00	C. Sward	IWL-043-002	NP-99-11274	RI	CRS 200004138
VCC-06	2000RFO	VT-3C	<input checked="" type="checkbox"/>	<input type="checkbox"/>	6/1/00	C. Sward	IWL-043-003	NP-99-11274	RI	CRS 200004138
VCC-07	2000RFO	VT-3C	<input checked="" type="checkbox"/>	<input type="checkbox"/>	6/1/00	C. Sward	IWL-043-004	NP-99-11274	NRI	Acceptable per RE review
VCC-08	2000RFO	VT-3C	<input checked="" type="checkbox"/>	<input type="checkbox"/>	5/26/00	R. Namperumal	IWL-068-001	NP-99-11274	RI	Acceptable per RE review
VCC-09	2000RFO	VT-3C	<input checked="" type="checkbox"/>	<input type="checkbox"/>	6/1/00	C. Sward	IWL-068-002	NP-99-11274	NRI	Acceptable per RE review
VCC-10	2000RFO	VT-3C	<input checked="" type="checkbox"/>	<input type="checkbox"/>	5/31/00	C. Sward	IWL-068-003	NP-99-11274	RI	CRS 200004138
VCC-11	2000RFO	VT-3C	<input checked="" type="checkbox"/>	<input type="checkbox"/>	6/1/00	C. Sward	IWL-068-004	NP-99-11274	NI	
VCC-12	2000RFO	VT-3C	<input checked="" type="checkbox"/>	<input type="checkbox"/>	5/26/00	R. Namperumal	IWL-088-001	NP-99-11274	NRI	Acceptable per RE review
VCC-13	2000RFO	VT-3C	<input checked="" type="checkbox"/>	<input type="checkbox"/>	5/31/00	C. Sward	IWL-088-002	NP-99-11274	RI	Acceptable per RE review

CATEGORY L-A

IWL EXAMINATION RESULTS

Containment Inservice Inspection Program
First Containment Inspection Interval

Component	Outage Number	Exam	Complete	Limited Exam	Exam Date	Examined By	Zone Number	Work Order Number	Results	Exam Notes
VCC-14	2000RFO	VT-3C	<input checked="" type="checkbox"/>	<input type="checkbox"/>	5/31/00	C. Sward	IWL-088-003	NP-99-11274	RI	CRS 200004138
VCC-15	2000RFO	VT-3C	<input checked="" type="checkbox"/>	<input type="checkbox"/>	5/25/00	R. Namperumal	IWL-088-004	NP-99-11274	RI	CRS 200004138
VCC-16	2000RFO	VT-3C	<input checked="" type="checkbox"/>	<input type="checkbox"/>	6/1/00	C. Sward	IWL-088-005	NP-99-11274	NRI	Acceptable per RE review
VCC-17	2000RFO	VT-3C	<input checked="" type="checkbox"/>	<input type="checkbox"/>	5/25/00	R. Namperumal	IWL-088-006	NP-99-11274	NRI	Acceptable per RE review
VCC-18	2000RFO	VT-3C	<input checked="" type="checkbox"/>	<input type="checkbox"/>	5/26/00	R. Namperumal	IWL-108-001	NP-99-11274	RI	Acceptable per RE review
VCC-19	2000RFO	VT-3C	<input checked="" type="checkbox"/>	<input type="checkbox"/>	6/1/00	C. Sward	IWL-108-002	NP-99-11274	RI	CRS 200004138
VCC-20	2000RFO	VT-3C	<input checked="" type="checkbox"/>	<input type="checkbox"/>	5/26/00	R. Namperumal	IWL-108-003	NP-99-11274	RI	CRS 200004138
VCC-21	2000RFO	VT-3C	<input checked="" type="checkbox"/>	<input type="checkbox"/>	5/25/00	R. Namperumal	IWL-108-004	NP-99-11274	RI	CRS 200004138
VCC-22	2000RFO	VT-3C	<input checked="" type="checkbox"/>	<input type="checkbox"/>	5/25/00	R. Namperumal	IWL-108-005	NP-99-11274	NRI	Acceptable per RE review
VCC-23	2000RFO	VT-3C	<input checked="" type="checkbox"/>	<input type="checkbox"/>	5/25/00	R. Namperumal	IWL-108-006	NP-99-11274	NRI	Acceptable per RE review
VCC-24	2000RFO	VT-3C	<input checked="" type="checkbox"/>	<input type="checkbox"/>	5/26/00	R. Namperumal	IWL-128-001	NP-99-11274	RI	CRS 200004138
VCC-25	2000RFO	VT-3C	<input checked="" type="checkbox"/>	<input type="checkbox"/>	6/1/00	C. Sward	IWL-128-002	NP-99-11274	RI	CRS 200004138
VCC-26	2000RFO	VT-3C	<input checked="" type="checkbox"/>	<input type="checkbox"/>	5/26/00	R. Namperumal	IWL-128-003	NP-99-11274	RI	CRS 200004138

CATEGORY L-A

IWL EXAMINATION RESULTS

Containment Inservice Inspection Program
First Containment Inspection Interval

Outage Number 2000RFO

Component	Outage Number	Exam	Complete	Limited Exam	Exam Date	Examined By	Zone Number	Work Order Number	Results	Exam Notes
VCC-27	2000RFO	VT-3C	<input checked="" type="checkbox"/>	<input type="checkbox"/>	5/25/00	R. Namperumal	IWL-128-004	NP-99-11274	RI	CRS 200004138
VCC-28	2000RFO	VT-3C	<input checked="" type="checkbox"/>	<input type="checkbox"/>	5/25/00	R. Namperumal	IWL-128-005	NP-99-11274	NRI	Acceptable per RE review
VCC-29	2000RFO	VT-3C	<input checked="" type="checkbox"/>	<input type="checkbox"/>	5/25/00	R. Namperumal	IWL-128-006	NP-99-11274	RI	Acceptable per RE review
VCC-30	2000RFO	VT-3C	<input checked="" type="checkbox"/>	<input type="checkbox"/>	5/31/00	C. Sward	IWL-148-001	NP-99-11274	RI	CRS 200004138
VCC-31	2000RFO	VT-3C	<input checked="" type="checkbox"/>	<input type="checkbox"/>	5/31/00	C. Sward	IWL-148-002	NP-99-11274	RI	CRS 200004138
VCC-32	2000RFO	VT-3C	<input checked="" type="checkbox"/>	<input type="checkbox"/>	5/31/00	C. Sward	IWL-148-003	NP-99-11274	RI	CRS 200004138
VCC-33	2000RFO	VT-3C	<input checked="" type="checkbox"/>	<input type="checkbox"/>	5/25/00	R. Namperumal	IWL-148-004	NP-99-11274	NRI	Acceptable per RE review
VCC-34	2000RFO	VT-3C	<input checked="" type="checkbox"/>	<input type="checkbox"/>	6/1/00	C. Sward	IWL-148-005	NP-99-11274	RI	CRS 200004138
VCC-35	2000RFO	VT-3C	<input checked="" type="checkbox"/>	<input type="checkbox"/>	5/25/00	R. Namperumal	IWL-148-006	NP-99-11274	RI	CRS 200004138
VCC-36	2000RFO	VT-3C	<input checked="" type="checkbox"/>	<input type="checkbox"/>	5/26/00	R. Namperumal	IWL-168-001	NP-99-11274	RI	Acceptable per RE review
VCC-37	2000RFO	VT-3C	<input checked="" type="checkbox"/>	<input type="checkbox"/>	5/31/00	C. Sward	IWL-168-002	NP-99-11274	RI	CRS 200004138
VCC-38	2000RFO	VT-3C	<input checked="" type="checkbox"/>	<input type="checkbox"/>	5/26/00	R. Namperumal	IWL-168-003	NP-99-11274	RI	CRS 200004138
VCC-39	2000RFO	VT-3C	<input checked="" type="checkbox"/>	<input type="checkbox"/>	5/25/00	R. Namperumal	IWL-168-004	NP-99-11274	NRI	Acceptable per RE review

CATEGORY L-A

IWL EXAMINATION RESULTS

Containment Inservice Inspection Program
First Containment Inspection Interval

Outage Number 2000RFO

Component	Outage Number	Exam	Complete	Limited Exam	Exam Date	Examined By	Zone Number	Work Order Number	Results	Exam Notes
VCC-40	2000RFO	VT-3C	<input checked="" type="checkbox"/>	<input type="checkbox"/>	5/25/00	R. Namperumal	IWL-168-005	NP-99-11274	NRI	Acceptable per RE review
VCC-41	2000RFO	VT-3C	<input checked="" type="checkbox"/>	<input type="checkbox"/>	5/25/00	R. Namperumal	IWL-168-006	NP-99-11274	RI	CRS 200004138
VCC-42	2000RFO	VT-3C	<input checked="" type="checkbox"/>	<input type="checkbox"/>	5/26/00	R. Namperumal	IWL-DOME-001	NP-99-11274	NRI	Acceptable per RE review
VCC-43	2000RFO	VT-3C	<input checked="" type="checkbox"/>	<input type="checkbox"/>	6/1/00	C. Sward	IWL-DOME-002	NP-99-11274	NRI	Acceptable per RE review
VCC-44	2000RFO	VT-3C	<input checked="" type="checkbox"/>	<input type="checkbox"/>	5/26/00	R. Namperumal	IWL-DOME-003	NP-99-11274	NRI	Acceptable per RE review
VCC-45	2000RFO	VT-3C	<input checked="" type="checkbox"/>	<input type="checkbox"/>	5/25/00	R. Namperumal	IWL-DOME-004	NP-99-11274	NRI	Acceptable per RE review
VCC-46	2000RFO	VT-3C	<input checked="" type="checkbox"/>	<input type="checkbox"/>	5/25/00	R. Namperumal	IWL-DOME-005	NP-99-11274	RI	CRS 200004138
VCC-47	2000RFO	VT-3C	<input checked="" type="checkbox"/>	<input type="checkbox"/>	5/25/00	R. Namperumal	IWL-DOME-006	NP-99-11274	NRI	Acceptable per RE review
VCC-48	2000RFO		<input checked="" type="checkbox"/>	<input type="checkbox"/>	6/1/00	C. Sward	IWL-DOME-007	NP-99-11274	RI	CRS 200004138



**INDIAN POINT UNIT 2
CONTAINMENT INSERVICE INSPECTION
FIRST PERIOD EXAMINATIONS**



**Category L-A, Concrete Examinations
Tab D - Inspection Records**



EXHIBIT A

CONTAINMENT INSERVICE INSPECTION
RECORD OF VT-3C EXAMINATION
DEMONSTRATION OF REMOTE EXAMINATION METHOD

STATION/UNIT: Indian Point 2

DATE: 5-25-2000

EQUIPMENT USED:

CELESTRON GRANT 20X80 BINOCULARS, NO. 990176

DESCRIPTION OF DEMONSTRATION: (Include discussion of approximate viewing distance, lighting conditions and resolution achieved.)

The attached test chart with 4 line markings of thickness ranging 0.015", 0.03", 0.045" and 0.060" to represent the cracks was held near the containment wall and the binoculars mounted on a tripod was set at a distance approximately 200 feet.

Weather condition was: clear, bright sunlight with light meter reading > 1000 foot candles.

RESULT: All the 4 lines in the test chart were clearly visible

LIMITATIONS:

DEMONSTRATION PERFORMED BY:

Signature: R. Nampurath
(R. NAMPURATH)

Date: 5-25-2000

DEMONSTRATION WITNESSED BY:

Signature: James M. Doyle

Date: 5/25/2000

RESPONSIBLE ENGINEER REVIEW:

Signature: BAE

Date: 6/30/00

AUTHORIZED NUCLEAR INSPECTOR (ANII) REVIEW:

Signature: _____

Date: _____

.015"

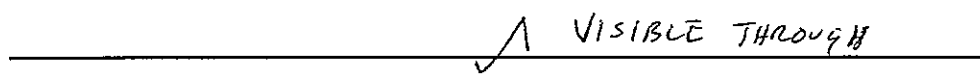

✓ VISIBLE THROUGH
BINOCULARS CELESTRON 20X80
NO. 990176 SET ON A TRIPOD
ABOUT 185' to 200' FROM THE
CONCRETE CONTAINMENT CYLINDER WALL
ADJACENT TO EQUIPMENT HATCH.

1

.030"



✓ VISIBLE

2

.045"



✓ VISIBLE

3

.060"



✓ VISIBLE

4

WEATHER CONDITION:
CLEAR, BRIGHT SUNLIGHT
Light Meter Reading > 1000 ft light
candles

VISIBILITY CHECK PERFORMED
BY: R. Mendenhall
10.10 AM. 5-25-2000

WITNESSED BY: J. M. Doyle
(TEST CHART HOLDER) 5/25/2000

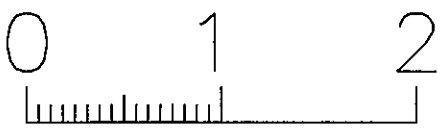

Vantage Points Used in Remote Visual Inspection

Vantage Point	Description	Zones Examined
A	Along edge of road	IWL-XXX-001 from 034 to 088
B	Along edge of road	IWL-XXX-001 from 088 to DOME
C	Along edge of road	IWL-XXX-006 from 088 to DOME
D	Along edge of road	IWL-XXX-006 from 088 to DOME, IWL-XXX-005 from 108 to DOME
E	Along edge of road	IWL-XXX-005 from 108 to DOME
F	Along edge of road	IWL-XXX-004 from 108 to DOME
G	Corner of Turbine Building roof near tank platform	IWL-XXX-004 from 088 to DOME, IWL-XXX-003 from 068 to DOME
H	Edge of Turbine Building roof	IWL-XXX-003 from 068 to DOME, IWL-XXX-002 from 088 to DOME
J	Edge of Turbine Building roof	IWL-XXX-002 from 088 to DOME, IWL-XXX-001 from 088 to DOME
K	Platform on unit 1 stack	IWL-DOME-002, IWL-DOME-003, IWL-DOME-004, IWL-DOME-007

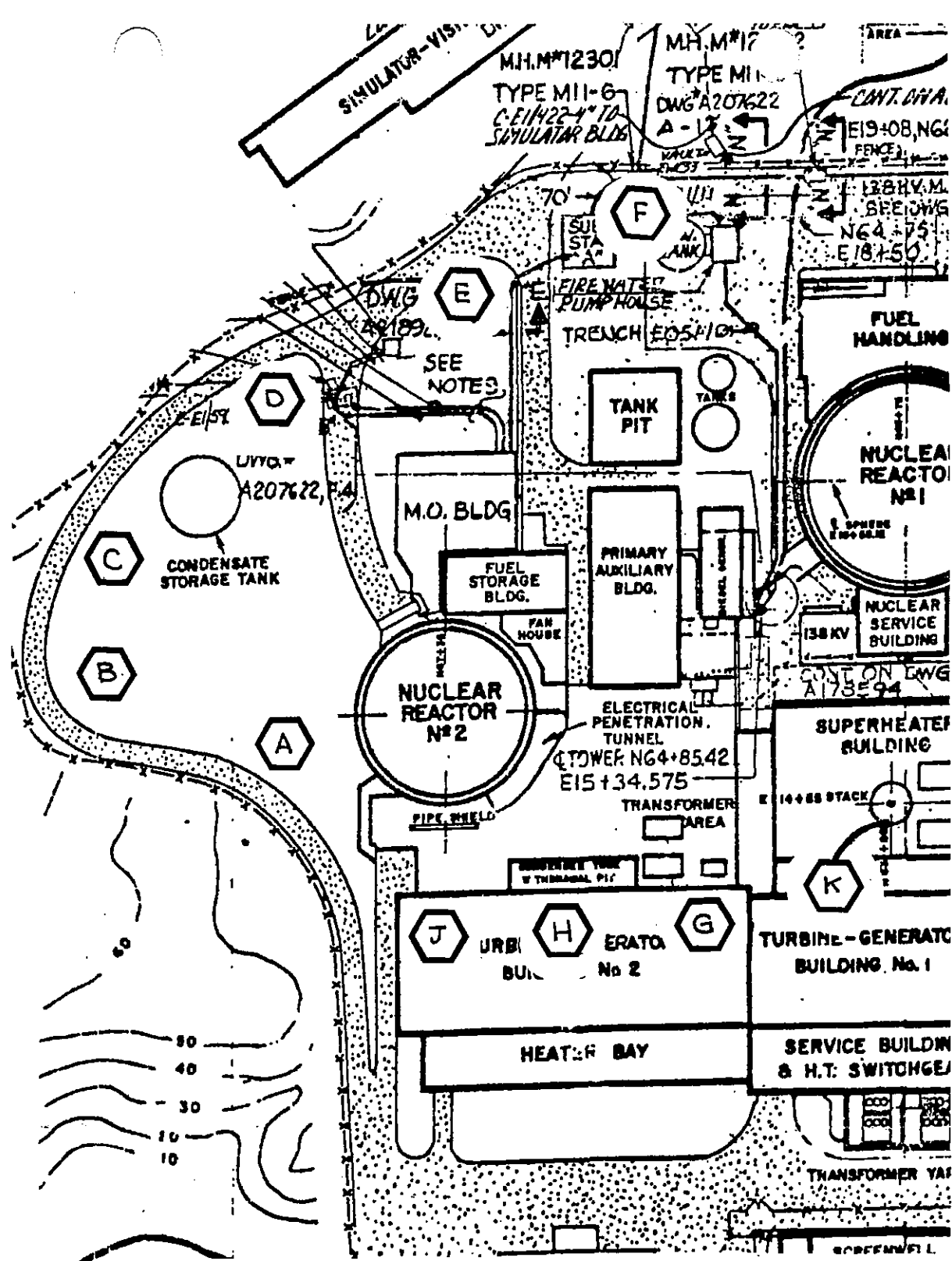



EXHIBIT A

CONTAINMENT INSERVICE INSPECTION
RECORD OF VT-3C EXAMINATION
DEMONSTRATION OF REMOTE EXAMINATION METHOD

STATION/UNIT: Indian Point 2 DATE: 6/1/00

EQUIPMENT USED:

Mag-Lite flashlight

DESCRIPTION OF DEMONSTRATION: (Include discussion of approximate viewing distance, lighting conditions and resolution achieved.)

Because of access limitations, examinations need to be performed at approximately 20 feet
using the naked eye. Available optical aides do not provide resolution at this short distance.
Ambient lighting is approximately 50 ft-candles and the flashlight provides additional spot
illumination (approx. 50 ft-candles). Hairline cracking is visible under these conditions, therefore
this distance and illumination is considered adequate for identifying conditions that would be
considered significant.

LIMITATIONS:

The flashlight shall be checked every four hours to ensure that lighting level is maintained.

DEMONSTRATION PERFORMED BY:

Signature: Chris Sward Date: 6/1/00

DEMONSTRATION WITNESSED BY:

Signature: Jim Doyle by C. Sward Date: 6/1/00

RESPONSIBLE ENGINEER REVIEW:

Signature: Basler Date: 6/11/00

AUTHORIZED NUCLEAR INSPECTOR (ANII) REVIEW:

Signature: _____ Date: _____



FORM VT-3C
CONTAINMENT INSERVICE INSPECTION
RECORD OF VT-3C EXAMINATION

STATION/UNIT: Indian Point 2 COMPONENT NO.: VCC-01
 ZONE NUMBER: IWL-034-001 DRAWING NO.: 320835
 EQUIPMENT USED: Celestron Giant 20x80 Binoculars (Ser. No. 990176)

Work Order No. NP-99-11274

Recording Conditions	RI	NRI	NI	NA	Comments
7.1.1.a Leaching or chemical attack	X				1
7.1.1.b Abrasion or corrosion			X		
7.1.1.c Popouts or voids			X		
7.1.1.d Scaling			X		
7.1.1.e Spalling			X		
7.1.1.f Corrosion staining			X		
7.1.1.g Cracks			X		
7.1.1.h Settlement or deflection			X		
7.1.1.i Exposed reinforcing steel			X		
7.1.1.j Coating deterioration				X	
Other					

(Note: Sketches may be attached to clarify inspection areas and locations of indications.)

EXAMINED BY: C. Sward *C. Sward* DATE: 5/26/00

RESPONSIBLE ENGINEER REVIEW:

Acceptable: Yes No (VT-1C Examination Required)

Comments: The leaching is very minor and is not significant relative to the containment integrity.

Signature: *[Signature]* Date: 6/30/00

AUTHORIZED NUCLEAR INSPECTOR REVIEW:

Signature: _____ Date: _____



FORM VT-3C (cont.)
CONTAINMENT INSERVICE INSPECTION
RECORD OF VT-3C EXAMINATION

STATION/UNIT: Indian Point 2 COMPONENT NO.: VCC-01

No.	Comment	Initials
1	Minor area of leaching from small patch at top of mat.	CAS



FORM VT-3C
CONTAINMENT INSERVICE INSPECTION
RECORD OF VT-3C EXAMINATION

STATION/UNIT: Indian Point 2 COMPONENT NO.: VCC-02
 ZONE NUMBER: IWL-034-002 DRAWING NO.: 320836
 EQUIPMENT USED: Mag-Lite flashlight

Work Order No. NP-99-11274

Recording Conditions	RI	NRI	NI	NA	Comments
7.1.1.a Leaching or chemical attack			X		
7.1.1.b Abrasion or corrosion			X		
7.1.1.c Popouts or voids		X			1
7.1.1.d Scaling			X		
7.1.1.e Spalling			X		
7.1.1.f Corrosion staining			X		
7.1.1.g Cracks			X		
7.1.1.h Settlement or deflection			X		
7.1.1.i Exposed reinforcing steel			X		
7.1.1.j Coating deterioration		X			2
Other					

(Note: Sketches may be attached to clarify inspection areas and locations of indications.)

EXAMINED BY: C. Sward *C. Sward* DATE: 6/1/00

RESPONSIBLE ENGINEER REVIEW:

Acceptable: Yes No (VT-1C Examination Required)

Comments: The conditions noted do not reflect any degradation of the containment concrete and are not significant relative to containment integrity.

Signature: *RC Sward* Date: 6/30/00

AUTHORIZED NUCLEAR INSPECTOR REVIEW:

Signature: _____ Date: _____

FORM VT-3C (cont.)
CONTAINMENT INSERVICE INSPECTION
RECORD OF VT-3C EXAMINATION

STATION/UNIT: Indian Point 2 COMPONENT NO.: VCC-02

No.	Comment	Initials
1	There are several small pockets of unconsolidated concrete ("honeycomb") at the very bottom edge of the mat. These areas are due to lack of proper consolidation or loss of paste during original concrete placement and do not represent degradation.	CAS
2	There are a number of areas within this zone where the coating is flaking and peeling. There is no evidence that this is due to degradation of the concrete substrate. It is a coatings related issue and not containment degradation.	CAS

FORM VT-3C
 CONTAINMENT INSERVICE INSPECTION
 RECORD OF VT-3C EXAMINATION

STATION/UNIT: Indian Point 2 COMPONENT NO.: VCC-04
 ZONE NUMBER: IWL-043-001 DRAWING NO.: 320838
 EQUIPMENT USED: Celestron Giant 20x80 Binoculars (Ser. No. 990176)

Work order No. NP-99-11274

Recording Conditions	RI	NRI	NI	NA	Comments
7.1.1.a Leaching or chemical attack	X				2,3
7.1.1.b Abrasion or corrosion			X		
7.1.1.c Popouts or voids	X				8,9
7.1.1.d Scaling			X		
7.1.1.e Spalling	X				4
7.1.1.f Corrosion staining			X		
7.1.1.g Cracks			X		
7.1.1.h Settlement or deflection			X		
7.1.1.i Exposed reinforcing steel	X				4,5,6,7
7.1.1.j Coating deterioration				X	
Other		X			1

(Note: Sketches may be attached to clarify inspection areas and locations of indications.)

EXAMINED BY: R. Namperumal *R. Namperumal* DATE: 5/26/00

RESPONSIBLE ENGINEER REVIEW:

Acceptable : Yes No (VT-1C Examination Required)

Comments: _____

Signature: *R. Namperumal* Date: 6/30/00

AUTHORIZED NUCLEAR INSPECTOR REVIEW:

Signature: _____ Date: _____

FORM VT-1C
CONTAINMENT INSERVICE INSPECTION
RECORD OF VT-1C EXAMINATION

STATION/UNIT: Indian Point 2 COMPONENT NO.: VCC-04
 ZONE NUMBER: IWL-043-001 DRAWING NO.: 320838
 EQUIPMENT USED: Celestron Giant 20x80 Binoculars (Ser. No. 990176)

Work Order No. NP-99-11274

Recording Conditions	RI	NRI	NI	NA	Comments
7.1.1.a Leaching or chemical attack	X				2,3
7.1.1.b Abrasion or corrosion			X		
7.1.1.c Popouts or voids	X				8,9
7.1.1.d Scaling			X		
7.1.1.e Spalling	X				4
7.1.1.f Corrosion staining			X		
7.1.1.g Cracks			X		
7.1.1.h Settlement or deflection			X		
7.1.1.i Exposed reinforcing steel	X				4,5,6,7
7.1.1.j Coating deterioration				X	
Other		X			1

(Note: Sketches may be attached to clarify inspection areas and locations of indications.)

EXAMINED BY: R. Namperumal *R. Namperumal* DATE: 5/26/00

RESPONSIBLE ENGINEER REVIEW:

Acceptable: Yes No
 Engineering Evaluation Required: Yes No Evaluation No.: CRS 2000 04138

Comments: The exposed steel (comment items 4&5) requires evaluation. The other items are not significant relative to containment integrity.

Signature: *R. Namperumal* Date: 6/7/00

AUTHORIZED NUCLEAR INSPECTOR (ANII) REVIEW:

Signature: _____ Date: _____



FORM VT-3C (cont.)
 CONTAINMENT INSERVICE INSPECTION
 RECORD OF VT-3C EXAMINATION

STATION/UNIT: Indian Point 2 COMPONENT NO.: VCC-04

No.	Comment	Initials
1	Non-uniformity of surface color and texture observed at various locations in the zone. The condition does not indicate significant material deterioration of the concrete.	RN
2	Leaching over a length of 20' close to joint from grout patch at the construction joint. See Photo 00060109	RN
3	Leaching from 9" dia. Patch at top of basemat at junction of wall. See Photo 00060108	RN
4	Cadmium exposure due to spalling 9" X 3", insufficient concrete cover. (less than 1/2"). See photo 00060107.	RN
5	Vertical rebar exposure with rust mark maximum 9" at 10 locations over 20' width at basemat junction. See Photos 00060108 and 00060111	RN
6	Ribs of some embedded steel (scrap?) exposed at the surface. See Photo 00060110	RN
7	Scrap steel exposed at the surface. See Photo 00060112	RN
8	form tie hole not filled. See Photo 00060113	RN
9	form tie hole only part filled. See Photo 00060107 and 00060113	RN

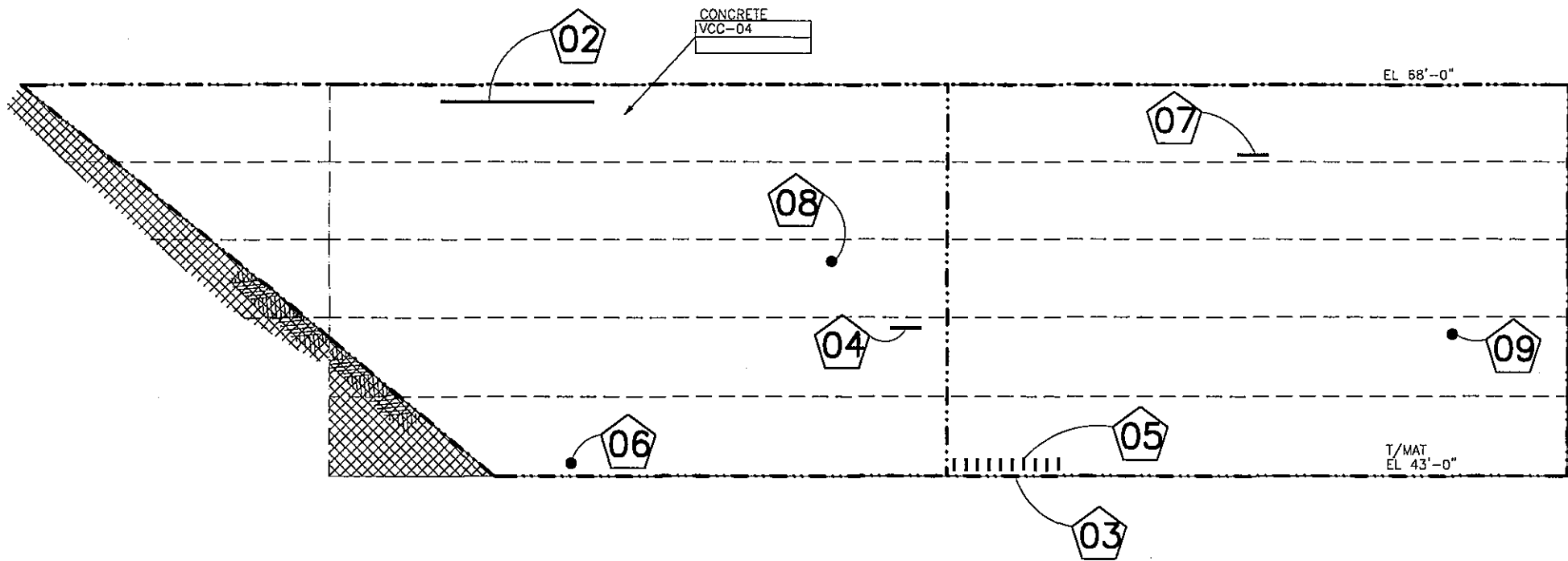

CONCRETE INSPECTION ZONE IWL-043-001
 (EXTERIOR DEVELOPED VIEW, LOOKING FROM OUTSIDE)

XX -DENOTES COMMENT NUMBER ON INSPECTION FORM.

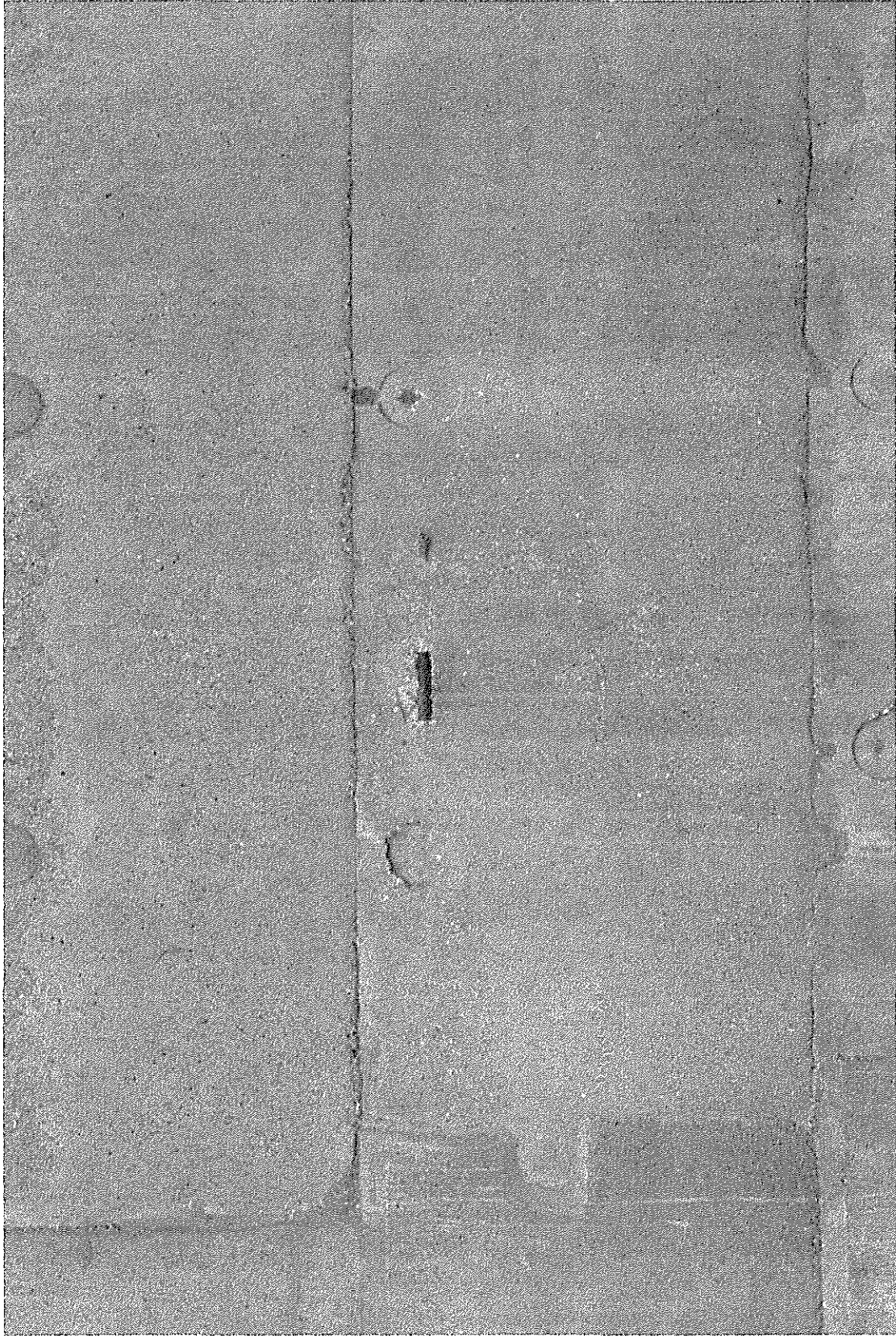

00060107.jpg

IWL-043-001



00060108.jpg

IWL-043-001

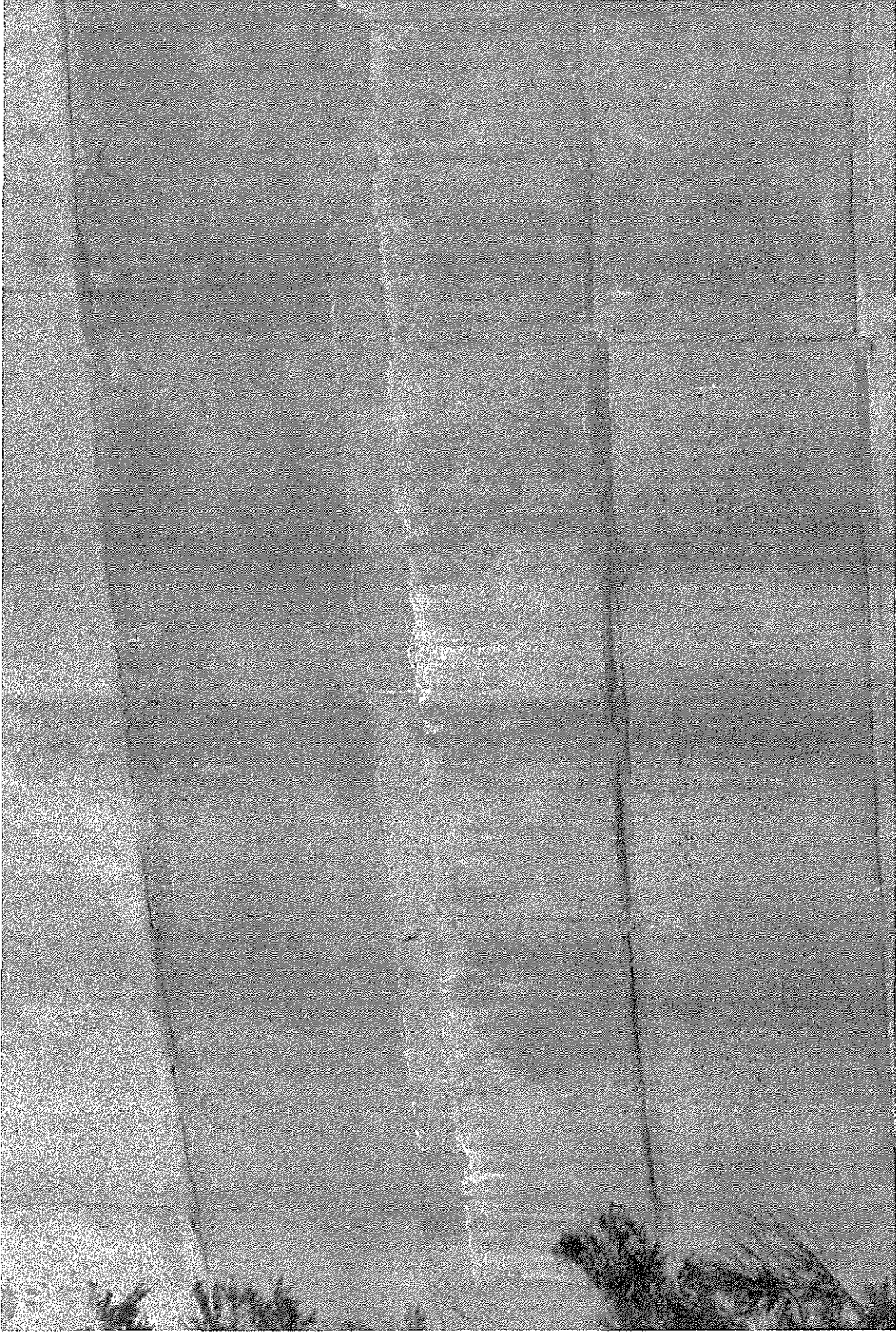

00060109.jpg

IWL-043-001



0060110.jpg

IWL-043-001



IWL-043-001

00060111.jpg

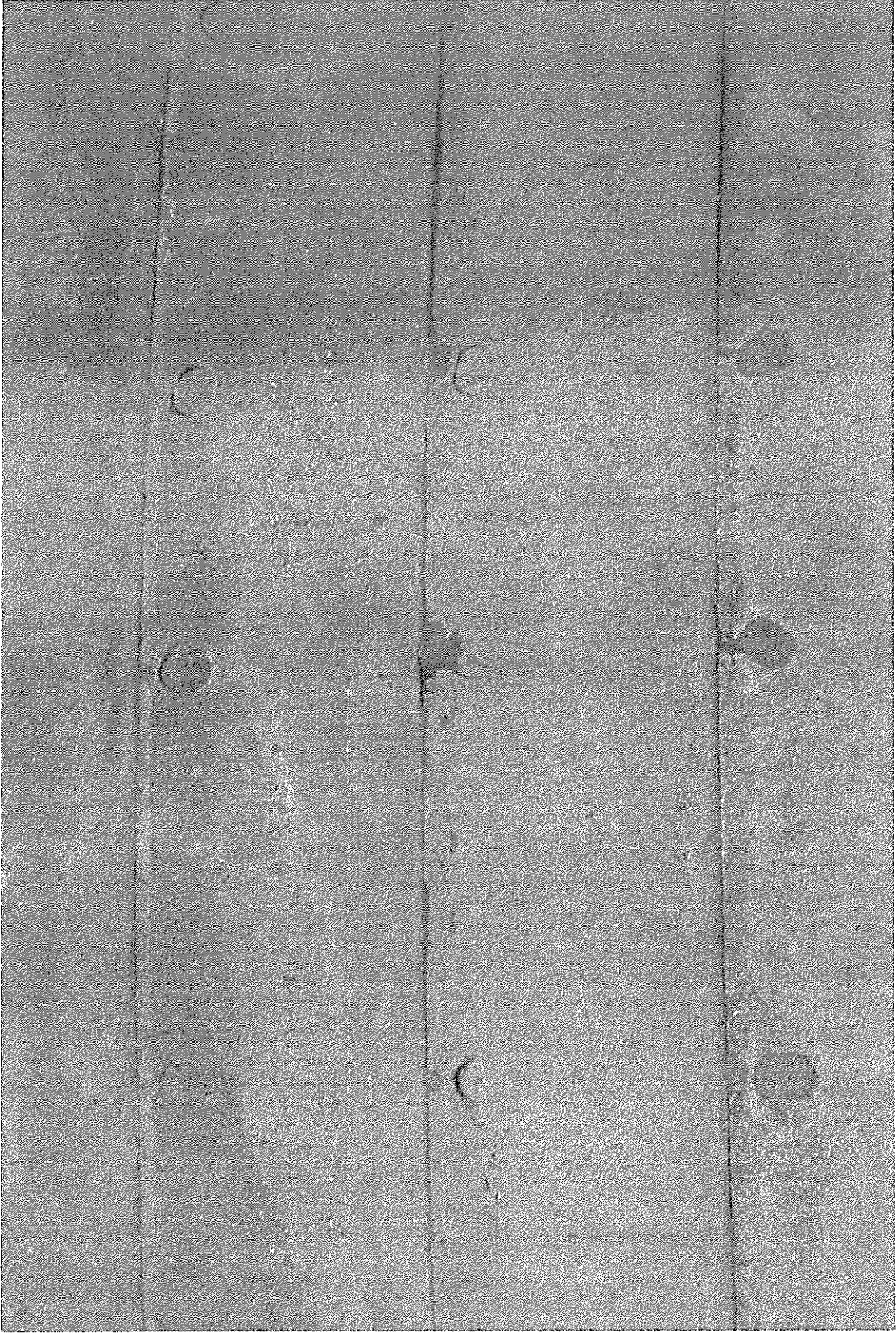

00060112.jpg

IWL-043-001

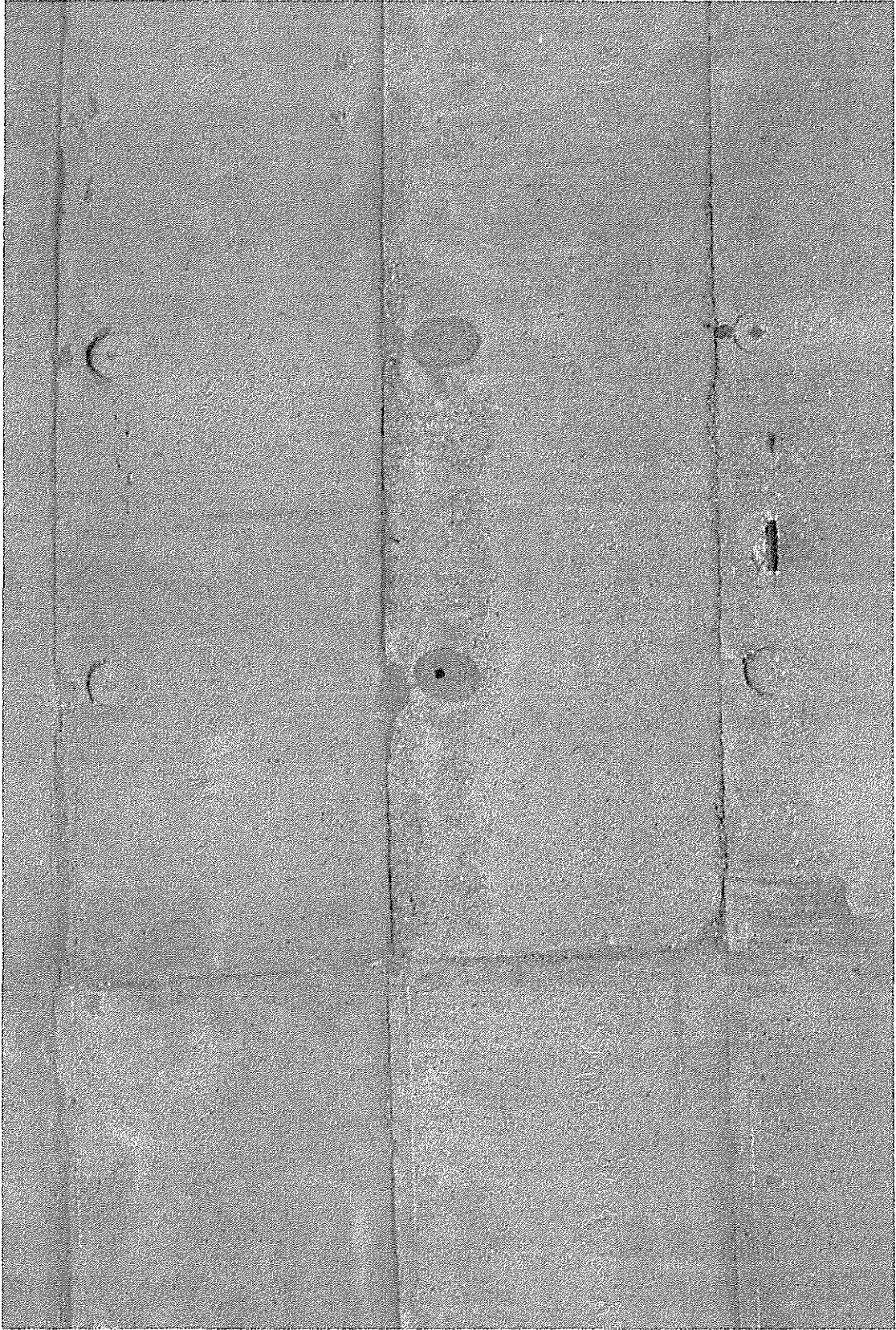

IWL-043-001

00060113.jpg