

Status Report –

Seismic Performance of Multiple Reactors on a Common Foundation

Manuscript Completed: December 2011

Prepared by
J. Nie, X. Wei, J. Braverman

Department of Nuclear Science and Technology
Brookhaven National Laboratory
P.O. Box 5000
Upton, NY 11973-5000

T. Herrity, NRC Project Manager

Structural, Geotechnical and Seismic Engineering Branch
Office of Research - Division of Engineering
US Nuclear Regulatory Commission
Washington, D.C. 20555-0001

NRC Job Code V-6096

ABSTRACT

The Office of Nuclear Regulatory Research (RES) of the Nuclear Regulatory Commission (NRC) sponsored Brookhaven National Laboratory (BNL) under NRC Job Code V-6096 to assess the seismic performance of multiple modular reactors on a common foundation. The goal of this project is to determine whether the current modeling/analysis methods, computational tools, and regulatory positions can address, with sufficient accuracy, the possible response variations due to the multiple modular construction approach. The initial period of performance was planned for August 2010 to July 2012. However, the NRC/RES has decided to discontinue this project due to budget constraints. The NRC requested BNL to bring the project to a logical conclusion and to document the work performed, so that the project could be reinstated in the future in an efficient manner if the staff decides to do so.

This report presents the status of the project, including the research plan, intermediate research results, and remaining tasks to achieve the original research goal. More specifically, it describes the background of the planned research, the original research plan, input spectra development, seed record selection, synthetic input motion generation, the ANSYS model development, determination of structural dynamic characteristics, generation of SASSI model, and the remaining tasks to achieve the original research goal.

BNL believes that the project is extremely valuable for assessing the adequacy and applicability of the current SRP and RGs for multiple modular reactors on a common foundation and providing recommendations on updates of these documents. This type of information and updated guidance would be important in supporting NRC/NRO during their licensing review activities of small modular reactors. Significant seismic issues in the proposed small modular reactor designs, which should be investigated, include module-module interaction, soil-foundation-module interaction, deeply embedded or completely buried foundations, the use of base-isolation devices, staged construction sequence, and the impact of water in a foundation pool on the seismic performance of multiple submerged modules.

TABLE OF CONTENTS

ABSTRACT.....	iii
LIST OF FIGURES.....	vii
LIST OF TABLES.....	ix
1 INTRODUCTION.....	1
1.1 Background.....	1
1.2 Scope of Effort.....	1
1.3 Progress Overview.....	2
1.3.1 Task One.....	2
1.3.2 Task Two.....	3
1.3.3 Task Three.....	3
2 THE RESEARCH AGENDA.....	5
2.1 Significant Seismic Issues for SMRs.....	5
2.2 The Analysis Plan.....	6
2.2.1 Basic Layout and Layout Permutations.....	6
2.2.2 Finite Element Model.....	8
2.2.3 Wall and Basemat Thickness Variation.....	8
2.2.4 Dry and Wet Conditions.....	8
2.2.5 Soil Condition Variation.....	8
2.2.6 Earthquake Records and Three Directional Effect.....	9
2.2.7 Computer Codes and Analyses.....	9
2.2.8 Response Evaluation.....	10
3 DEVELOPMENT OF INPUT MOTIONS.....	11
3.1 Development of Input Response Spectra.....	11
3.2 Generation of Input Acceleration Time Histories.....	15
3.2.1 Determination of Seed Records.....	15
3.2.2 Generation of Synthetic Acceleration Time Histories.....	20
4 DEVELOPMENT OF FINITE ELEMENT MODELS.....	25
4.1 Development of the ANSYS Model.....	25
4.2 ANSYS Modal Analysis.....	27
4.3 Transferring ANSYS Model to SASSI House Model.....	41
5 ROAD AHEAD.....	Error! Bookmark not defined.
5.1 Remaining Tasks.....	47
5.2 Remarks on Water-Structure Interaction.....	48
5.3 List of Important Files.....	49
5.3.1 On ABACUS (Jinsuo Nie’s Workstation).....	49
5.3.2 On Spot (BNL BLC Cluster Head Node).....	52
5.3.3 On Xing Wei’s Workstation.....	53
6 REFERENCES.....	55

LIST OF FIGURES

Figure 2-1 Basic Layout Configuration	7
Figure 3-1 Horizontal 5%-Damped Response Spectra	13
Figure 3-2 Vertical 5%-Damped Response Spectra.....	13
Figure 3-3 Comparison of NGA180 Fault Normal Direction and Horizontal Envelop Spectrum.....	16
Figure 3-4 Comparison of NGA180 Fault Parallel Direction and Horizontal Envelop Spectrum.....	17
Figure 3-5 Comparison of NGA180 Vertical and Horizontal Envelop Spectrum	17
Figure 3-6 Comparison of NGA180 Fault Normal Direction and Vertical Envelop Spectrum	18
Figure 3-7 Comparison of NGA180 Fault Parallel Direction and Vertical Envelop Spectrum	18
Figure 3-8 Comparison of NGA180 Vertical Direction and Vertical Envelop Spectrum.....	19
Figure 3-9 NGA180 Wave Forms before Chopped.....	19
Figure 3-10 Seed Record NGA 180 FP	22
Figure 3-11 Synthetic Record SMR_H1 based on Seed Record NGA 180 FP	22
Figure 3-12 Seed Record NGA 180 FN.....	23
Figure 3-13 Synthetic Record SMR_H2 based on Seed Record NGA 180 FN	23
Figure 3-14 Seed Record NGA 180 V.....	24
Figure 3-15 Synthetic Record SMR_V based on Seed Record NGA 180 V	24
Figure 4-1 ANSYS Solid Model for the Foundation Perimeter Walls, Rib Walls, and Basemat.....	26
Figure 4-2 ANSYS Finite Element Model (Foundation, Containment, and Internal Structures).....	26
Figure 4-3 Cumulative Mass Fraction.....	28
Figure 4-4 Mode Shape 1: Long Wall	29
Figure 4-5 Mode Shape 2: Entire Model along Short Edge.....	29
Figure 4-6 Mode Shape 3: Short Wall (1 st mode) and Long Wall (2 nd Mode)	30
Figure 4-7 Mode Shape 4: Short Wall (1 st mode) and Long Wall (2 nd Mode) in Reverse Order	30
Figure 4-8 Mode Shape 5: Short Wall (1 st mode) and Basemat.....	31
Figure 4-9 Mode Shape 6: Long Wall (2 nd Mode).....	31
Figure 4-10 Mode Shape 7: Short Walls.....	32
Figure 4-11 Mode Shape 8: Short Walls and Rib Walls.....	32
Figure 4-12 Mode Shape 9: Long Wall and Basemat	33
Figure 4-13 Mode Shape 10: Rib Walls	33
Figure 4-14 Mode Shape 11: Long Walls (3 rd Mode), Short Walls, and Rib Walls	34
Figure 4-15 Mode Shape 12: Long Walls (3 rd Mode) and Rib Walls.....	34
Figure 4-16 Mode Shape 13: Rib Walls (1).....	35
Figure 4-17 Mode Shape 14: Rib Walls (2).....	35
Figure 4-18 Mode Shape 15: Rib Walls (3).....	36
Figure 4-19 Mode Shape 16: Rib Walls (4).....	36
Figure 4-20 Mode Shape 31: Short Walls (2 nd Mode), Rib Walls, and Containments.....	37
Figure 4-21 Mode Shape 35: Short Walls, Rib Walls, and Containments (Higher Mode).....	37

Figure 4-22 Mode Shape 39: Containments (2 nd Mode – Combination 1)	38
Figure 4-23 Mode Shape 40: Containments (2 nd Mode – Combination 2)	38
Figure 4-24 Mode Shape 41: Containments (2 nd Mode – Combination 3)	39
Figure 4-25 Mode Shape 63: Walls and Basemat (Higher Mode – Example 1)	39
Figure 4-26 Mode Shape 64: Walls and Basemat (Higher Mode – Example 2)	40

LIST OF TABLES

Table 3-1 Summary of CSDRS for the New Light Water Reactor Designs..... 14

1 INTRODUCTION

1.1 Background

A modular build approach has been widely adopted by the currently proposed advanced reactor designs to allow the development of integrated plants, which may consist of one or more reactor modules placed at one time or sequentially during the plant life based on the projected electricity demand. Some of these designs feature multiple reactors on a common foundation. This new configuration and the corresponding staged construction sequence may lead to changes in seismic demands, stresses, and in-structure spectra, for the various structures, systems and components (SSCs), compared to the existing light water reactors and the new standard reactor designs.

BNL has been tasked in this research project, by the Office of Nuclear Regulatory Research (RES) of the Nuclear Regulatory Commission (NRC), under NRC Job Code V-6096, to determine whether the current modeling/analysis methods, computational tools, and regulatory positions can address, with sufficient accuracy, the possible response variations due to the phased construction approach of the multiple module design. The research will assess the applicability of regulatory guidance, analysis methods, and common computer codes through literature review and benchmark studies that can simulate the various stages of the plant throughout its life cycle.

Initially the period of performance was planned for August 2010 to July 2012. However, the NRC has been forced to discontinue this project due to budget constraints. The NRC requested BNL to bring the project to a logical conclusion and to document the work performed, so that the project could be reinstated in the future in an efficient manner if sufficient fiscal resources can be identified. With a description of the research plan and a summary of the progress made, the goal of this report is to provide a convenient starting point to the possible reinstatement of the project in an efficient manner.

BNL believes that the project is extremely valuable for assessing the adequacy and applicability of the current SRP and RGs for multiple modular reactors on a common foundation and providing recommendations on updates of these documents. This type of information and updated guidance would be important in supporting NRC/NRO during their licensing review activities of small modular reactors. Significant seismic issues in the proposed small modular reactor designs, which should be investigated, include module-module interaction, soil-foundation-module interaction, deeply embedded or completely buried foundations, the use of base-isolation devices, staged construction sequence, and the impact of water in a foundation pool on the seismic performance of multiple submerged modules.

1.2 Scope of Effort

The scope of the work is to investigate the seismic demands on the SSCs of single or multiple operating modules for different multi-module configurations on a common foundation that may exist during the life of an integrated plant. Besides the major analytical effort planned for this project, the scope includes review of current literature on seismic response of foundations and structures, as well as the corresponding seismic evaluation methods (including applicable NUREGs, RGs, and SRP Chapters, and referenced commercial standards/codes and computer programs). In addition, the scope of work includes reviewing existing design data, if available, for the proposed modular reactor designs to support the development of analytical models and recommendations for enhancement of regulatory guidance applicable to multiple reactors on a common foundation and the potentially staged

construction process. It is recognized that soil-structure interaction (SSI) is one of the major influential factors on the seismic response of the multiple reactors and their foundation.

More specifically, the project was planned to include the following three tasks:

Task One: Review and Characterization of Modular Plant Foundations

Review existing literature on the calculation of seismic demands on SSCs in nuclear island structures on a monolithic foundation including review of applicable recent seismic events. Review existing literature for current NRC and other regulatory guidance for determining seismic loads and demands on SSCs and monolithic foundations. Discuss characteristics of proposed modular designs and their foundation design.

Task Two: Comparison of Predicted Responses

Compare modular design responses, structural demands and in-structure spectra – for single operating module and multi-operating modules – to the existing guidance. Use the results to assess impacts of multi-module variations on anticipated safety margins. Use actual earthquake data if available. If there is none available, use simulated earthquakes for comparisons.

Task Three: Seismic Design Recommendations

Develop recommendations for seismic design criteria and guidance that encompass variations of the basic module design for plants with multiple modules on a common foundation. Consider the safety requirements and recommend criteria to ensure that there will not be module-to-module interactions that would unacceptably lower the safety of the plant. Work on this task will also consider the combinations of the modules that can exist in the design.

1.3 Progress Overview

1.3.1 Task One

As part of the Task one work scope, the current group of small modular reactor (SMR) designs was reviewed to identify their unique seismic characteristics. SMRs are being promoted for both short-term deployment (before 2020) and longer-term deployment (after 2020). They fall into three primary categories: integrated light water PWRs (iPWRs); liquid metal reactors (LMRs); and high temperature gas reactors (HTGRs). The reviewed SMR designs are tabulated below:

iPWRs: NuScale and mPower

LMRs: 4S, PRISM, and Hyperion

HTGRs: PBMR and Prismatic

Overall, information on the seismic analysis and design of these SMRs is relatively limited as compared to other system information. Based on the review of the available information, significant seismic issues applicable to most of these SMRS are summarized in the next section; more details can be found in the Task 1 Letter Report [Ref. 2].

In addition to the review of the SMR designs, recent earthquake events affecting nuclear power plants were reviewed and documented. Details can be found in Appendix A of Reference 1.

An analysis plan was developed as part of this task to guide the research process for Task 2. The analysis plan is described in Section 2 of this report.

1.3.2 Task Two

Following the analysis plan, input response spectra were developed based on a review of the seismic specifications and analysis of the recent four standard light water reactor designs, i.e., ESBWR, AP1000, EPR, and US APWR. This approach was taken because it is expected that the SMRs will be constructed in various regions of the U.S. as the new light water reactors will be. Synthetic time histories have been generated based on properly selected seeds. These results are described in more detail in Section 3 and in Reference 3 as well.

An ANSYS model was developed for the basic layout configuration as proposed in the analysis plan. The model has a fine mesh, on which a modal analysis was performed and the dynamic characteristics of the entire model and major components can be determined. The ANSYS model was translated to a SASSI model using a tool adapted from a previous tool that can translate an LS-DYNA model to an SASSI model. More details on the ANSYS and SASSI models are provided in Section 4.

The seismic analysis of multiple modular reactors on a common foundation is relatively new to the nuclear energy community. There may be technical challenges that may not be known or adequately understood at this time. Remaining tasks to achieve the original research goal are briefly summarized in Section 5.

The original plan was to prepare a letter report documenting the review performed and the comparison of the structural responses of the foundation and various module configurations subjected to earthquake motions. A description of the seismic guidance used to analyze the various modular nuclear plant foundations were to be provided, including review of NRC documents (NUREGs, SRP chapter, RGs) and industry documents, as well as any limiting parameters.

1.3.3 Task Three

The original plan was to prepare a letter report documenting recommendations and guidance that encompass variations of the basic module design for plants with multiple modules on a common foundation. A description of the methodology used for the development of these recommendations were to be provided including the need for additional studies, if any, and the need for drafting of any suggested new or revised NRC documents (NUREGs, SRP chapter, and/or RGs).

The research findings of this project were envisioned to lead to a NUREG/CR report at the end of the project.

2 THE RESEARCH AGENDA

2.1 Significant Seismic Issues for SMRs

Based on the review of the available information for the proposed SMR designs, the more significant seismic issues applicable to most of these SMRS are summarized in the following; more details can be found in the Task 1 Letter Report [Ref. 2].

The proposed SMR designs are in general deeply embedded or completely buried for the benefit of reduced seismic demands and reduced ground footprint, the latter of which is helpful in minimizing the chance of natural and manmade missile strikes. The large embedment leads to seismic inputs to the modules different from the light water reactor designs where the soil-structure interaction (SSI) occurs more like a base excitation. The large embedment may limit siting to soil sites, where excavation would be less expensive. From a practical standpoint, deep excavations are very difficult and expensive where there are existing structures surrounding the excavation site. For the generic seismic design basis, definition of the certified seismic design response spectra (CSDRS) at the surface may not be appropriate and satisfaction of the 0.1g PGA criterion at the bottom of foundation, as specified in the current regulations for the new light water reactor designs, will need to be evaluated for applicability.

Since most of the designs have multiple modules, the module-to-module interaction is another aspect that must be studied. The effect of module-to-module interaction may come from the common base mat, foundation walls, and other surrounding medium (soil or water). This is different from the current operating and new light water reactor designs where multiple units, if present, are constructed at some distance apart so that seismic unit-to-unit interaction does not need to be considered. The seismic analysis of a coupled system, that include the RPV/containment module, basemat, foundation walls, and the soil/water, do not appear to be adequately addressed in the current staff guidance. In addition, the mathematical simulation procedures that have been generally accepted for SSI analysis for prediction of realistic seismic response should be reviewed for application to multiple modules below grade.

The SMRs can be constructed/installed in a staged fashion to meet the future power needs. The construction sequencing and the refueling scenario pose difficult problems for generic design certification. The staged construction/installation process can result in many different layout configurations that may have a significant impact on the seismic performance of the SMRs due to module-to-module interaction.

Many SMR designs appear to favor the application of seismic base isolation to the reactor. The effect of seismic isolation for underground structures needs to be studied in depth. Base isolation techniques have been successfully utilized for above ground structures to reduce the inertia load. For underground structures, the benefit of such devices may not be as great as those used for above ground structures. The long-term performance of base isolators and the initial and life inspection/maintenance costs of such devices should be considered in decision making when comparing the base isolation technology and the conventional construction. Due to the vertical flexibility of the base isolators and low horizontal stiffness, the reactor may be excited to induce large rocking and/or torsional motions. There is also a concern about the effect of the low frequency seismic input motions. In particular, these low frequency motions may resonate with the fluid sloshing mode. The performance of the seismic isolation system should also be studied for beyond-design-basis earthquakes. In addition, since the turbine generator buildings in these designs are in general supported by the seismic isolation devices on the same platform, design of the steam pipes connecting the steam generator to the turbine generator is critical.

2.2 The Analysis Plan

Based on the characteristics of the reviewed modular reactor designs and the unique seismic analysis issues associated with these designs, an analysis plan was developed for analytical studies to characterize the seismic response of multiple reactor modules on a common foundation, including the effects of sequential changes in configuration as additional modules are added over the plant's life. Several generic (technology-neutral) multiple module configurations were developed for detailed analysis in Task 2. The most broadly applicable configurations were selected for evaluation while considering the schedule and funding resources available. The finite element model, representing the basic configuration introduced below, was developed but then shelved with the intent to reexamine it if time and funds permit in the future. The planned study was to analyze a series of configuration permutations, examine characteristics of seismic performance, and identify the important parameters from multi-modular reactor designs that contribute the most to seismic response. The SMR designs are deeply embedded or completely buried in the ground. As a result, it is expected that there will be differences in their seismic response, as compared to surface- or close-to-surface- mounted structures. The configuration developed for detailed analysis in Task 2 is assumed to be completely embedded in the ground.

A suite of permutations regarding various parameters is planned for study in this research effort. These permutations will be implemented consistent with a typical sensitivity analysis, in which each permutation will be a deviation from a base case. This will limit the total number of permutations to a manageable number. If specific significant trends are identified during the study, this can be re-assessed and modified.

2.2.1 Basic Layout and Layout Permutations

The foundation for the base case was proposed to be 90' x 180' in plan and 80' in depth constructed from reinforced concrete. As shown in Figure 2-1, the base model contains 12 reactor/containment compartments of 30' x 30' in plan. There is a 30' wide corridor down the center for refueling access. The cylinders depict steel containments, which are assumed to be 60' tall and 15' in diameter. The reactor vessels inside the containments are not shown but will be modeled explicitly in the analysis. The containments are supported at the basemat and at 2/3 height to the side walls, for the case of a dry foundation (i.e., without water), and only at 2/3 height to the side walls for the case of a water-filled pool. Labels consisting of a letter and a number (e.g., A1) shown in the illustration next to each SMR module denote the specific location that is utilized later in this report when discussing the various permutations.

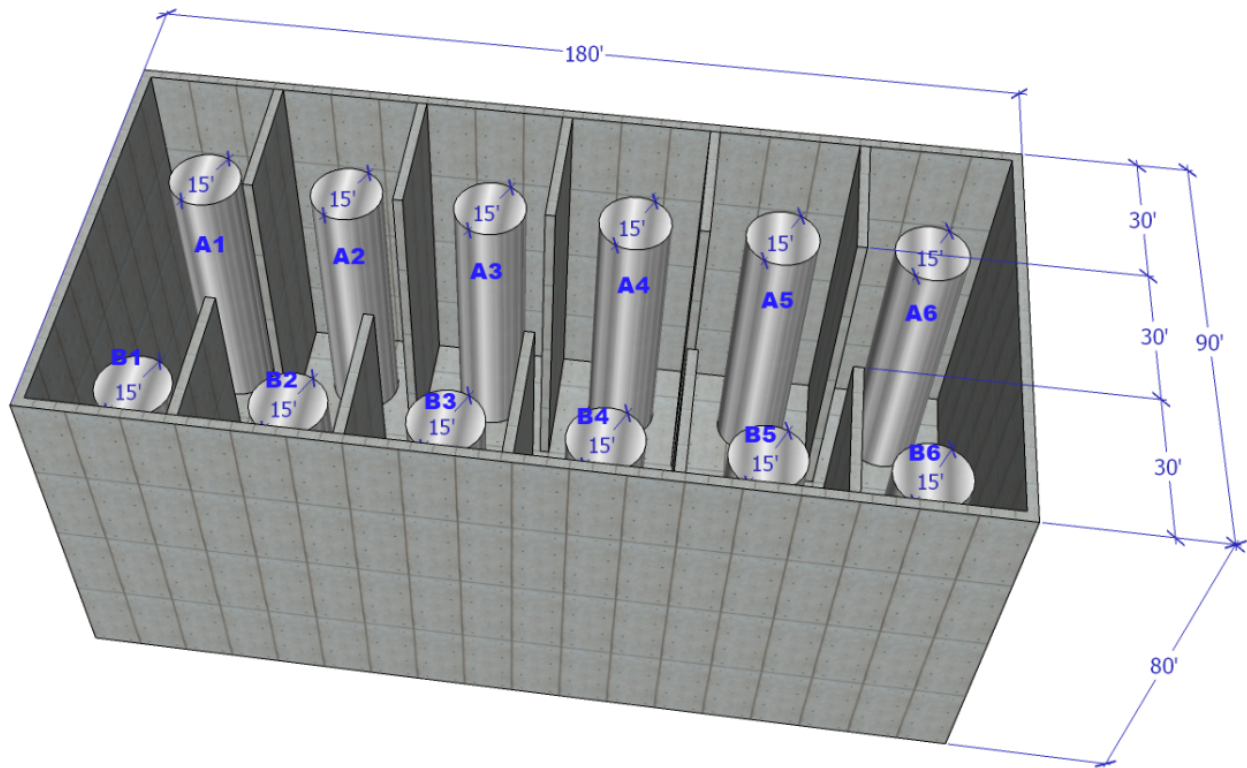

Figure 2-1 Basic Layout Configuration

In addition to the above base case analysis, the potential layout permutations include (A) depth, (B) plan dimensions, and (C) the location and number of in-place reactor/containment units, as detailed in the following:

(A) Depth:

1. A foundation depth of 50' and a containment height of 30';
2. A foundation depth of 110' and a containment height of 90'.

(B) Plan Dimensions (two variations):

1. The base case plan dimensions will be varied for a 6 containment installation (90'x90' in plan) ;
2. The base case plan dimensions will be varied for 30' diameter containments (45'x45' compartments; 135'x270' in plan) and for 45' diameter containments (60'x60' compartments; 180'x360' in plan).

(C) Location and Number of In-Place Reactor/Containment Units:

Different placement patterns will be analyzed for the base case dimensions and the controlling soil condition from the base case analyses. The exact number and locations will depend on the observed trends in response and available resources. The initially planned cases include:

1. An empty case;
2. Two (2) single unit cases: at a corner compartment (A1) and at a compartment close to the center (A3);
3. Two (A1, A2), four (A1 to A4), and six (A1 to A6) unit configurations on the one side of the corridor;
4. Two (A1, B1), four (A1, B1, A2, B2), six (A1 to A3, B1 to B3), and eight (A1 to A4, B1 to B4) unit configurations along the long dimension of the foundation plan;
5. Configurations of four (A2, A5, B2, B5) and eight (A1, A3, A4, A6, B1, B3, B4, B6) units placed evenly over the foundation.

2.2.2 Finite Element Model

The foundation walls and basemat and the cylindrical containments are generally modeled using shell elements. Beam element models of the containments may also be used, where appropriate, to facilitate parametric variations. The RPVs will be modeled using beam elements, either located inside the containment shell element models, or concentrically attached to containment beam element models. Soil will be modeled using 3-D solid elements or using recognized continuum formulations, depending on which computer code is used. Water will be modeled using 3-D solid elements, where feasible, or generally recognized approximations, where necessary.

Advantage will be taken of model and loading symmetry where appropriate, to reduce the finite element model size. A unit model for the containment with RPV will be developed to facilitate model development.

2.2.3 Wall and Basemat Thickness Variation

For the base case, the basemat is 8' thick and walls are 4' thick. One variation will be studied with increased basemat thickness of 12' and wall thickness of 8'.

2.2.4 Dry and Wet Conditions

The focus of this study will be for the base case without water. A water-filled pool will be considered as a variation of the base case.

2.2.5 Soil Condition Variation

Because of the large size of the excavation needed to fully embed the foundation, it is not expected that a rock site would be selected. Therefore, only soil sites are postulated. A range of soil stiffnesses will be analyzed, from 1,000 fps to 3,000 fps shear wave velocity. Shear wave velocity of 1,000 fps represents the lower bound for competent soil, in accordance with SRP 3.7.1. Shear wave velocity of 3,000 fps is representative of soft rock, as an upper bound.

Planned shear wave velocity variations will include 500 fps increments in the above-proposed range, resulting in a total of 5 cases. For each case, one soil layer with uniform properties is assumed to fully embed the foundation. More soil/rock layers will be defined below this layer, as needed in a particular computer code.

2.2.6 Earthquake Records and Three Directional Effect

Synthetic time histories will be developed, in accordance with the guidance in SRP 3.7 and RG 1.208, to match representative broadband spectra anchored at 0.3 g PGA. The spectral energy vs. frequency will be appropriate for the postulated range of soil conditions.

Real earthquake recordings will be used as seeds to develop the synthetic acceleration time histories that match the target spectra. To this end, the NUREG/CR-6728 or the PEER Strong Motion Databases will be used to choose appropriate records.

Both single directional and multi-directional inputs will be analyzed. Algebraic summation will be used for determining the response to multi-directional inputs, in accordance with RG 1.92 Rev. 2.

If any nonlinear effects are deemed significant enough to evaluate, multiple sets of time history records will be used, in accordance with the guidance in SRP 3.7.

2.2.7 Computer Codes and Analyses

There are a number of computer codes that have been used to perform SSI analysis, including SASSI, LS-DYNA, CLASSI, P-CARES, FLUSH, COMSOL, ABAQUS, and ADINA. There are two basic approaches for soil modeling in these codes: a layered soil column or explicit finite elements, with the former often being associated with linear frequency domain solutions and the latter being associated with linear/nonlinear time domain solutions. SASSI and LS-DYNA are two widely used representative codes for SSI analysis, corresponding to the two basic soil modeling approaches, layered soil column and finite element model, respectively.

SASSI and LS-DYNA have been selected for use in this study. BNL has extensive experience in using these two codes and both are available for use at BNL. SASSI is recognized as the nuclear industry *de facto* standard for SSI analysis. It has been the primary code used by applicants for seismic SSI analyses submitted to the NRC for licensing approval of NPPs. SASSI has the capability to address limitations inherent in some of the other codes. SASSI has the ability to consider embedment and flexible foundation (which CLASSI cannot), contains various finite element types (which are limited in P-CARES), and can perform 3-dimensional SSI analysis (which is limited to 2-D in FLUSH). The other codes such as LS-DYNA, COMSOL, ABAQUS, and ADINA are considered to be general-purpose finite element codes which can be used to perform SSI analysis but were not specifically written for that purpose.

In light of recent reports [e.g., Ref 4] on potentially unrealistic results produced by SASSI in certain situations and the concerns on the quality assurance of different versions of SASSI, it is important that its applicability and limitations for analysis of SMRs be well understood, especially for completely embedded structures. Therefore, some benchmarking of the SASSI code is planned by a combination of comparison to LS-DYNA, test data, and/or published known solutions.

LS-DYNA has the capability to explicitly model both soil and water, and appears to be a good fit for analysis of potential SMR configurations. LS-DYNA is actively developed and QA'd by Livermore Software Technology Corporation (LSTC). Its additional modeling and analysis capabilities may be required to address special conditions of importance for SMRs, such as sliding, uplifting, and contact element capability between surfaces, at the soil-structure interface. Comparison of SASSI and LS-DYNA

results can facilitate the identification of the potential limitations in SASSI and the establishment of the best modeling methods in LS-DYNA as well.

For the dry foundation case, both SASSI and LS-DYNA models are proposed. For the water-filled pool variation, the use of an LS-DYNA model to simulate water using 3-D volumetric elements will be investigated. Options for modeling the water in SASSI will be investigated, including the use of approximations previously implemented in the nuclear industry.

Linear analysis will be the first priority. Consideration of nonlinear effects will be selective, based on the linear analysis results.

2.2.8 Response Evaluation

Acceleration and displacement at locations on the containment, the concrete walls, and the basemat will be evaluated. In-structure response spectra will be generated at selected locations to develop response trends for the various permutations of the base case.

The linear analysis results will be evaluated to identify potentially significant nonlinear effects that might warrant investigation. Before proposing further investigation of a potentially significant nonlinear effect, a case study will be performed to support such a recommendation.

The results of the analyses will be used to develop and support the recommendations and guidance that will be developed as part of Task 3.

3 DEVELOPMENT OF INPUT MOTIONS

3.1 Development of Input Response Spectra

According to the analysis plan, the synthetic time histories to be used for the SMR SSI analysis will be developed to match representative broadband spectra anchored at 0.3 g PGA. Since this study does not restrict itself to any specific site, the input response spectra were developed based on a review of the certified seismic design response spectra (CSDRS) for the new light water reactor designs recently submitted for approval to the NRC under 10 CFR Part 52. The review was based on these CSDRS because it is expected that SMRs will be located throughout a large region of the US as are the new light water reactor designs. Based on these CSDRS, generic broadband response spectra were developed for use in this SMR study which essentially envelope the CSDRS of the new light water reactor designs.

Design control documents (DCDs) of the four new reactor designs, namely ESBWR, AP1000, EPR, and US APWR, have been reviewed to determine the characteristics of their CSDRS. Both Tier 1 and Tier2 DCDs were reviewed for consistency and in some cases, other related topical reports and revisions of the DCDs were reviewed to make sure that the information to be used is current. In addition to CSDRS, sections relating to the SSI analysis methodologies, time history synthesis methods, structural and soil modeling, and soil profiles, were also reviewed for useful information that would be applicable to similar aspects of the SMR SSI analysis.

Table 3-1 shows a summary of the major characteristics of the CSDRS that were reviewed. The CSDRS for ESBWR, AP1000, and US APWR are all based on the RG 1.60 spectra, but with some adjustments to take into account the high frequency (HF) content in ground motions typical for the CEUS. These adjustments by the applicants were believed to broaden the applicable region in the CEUS for siting these standard designs. In particular, the ESBWR design separately utilized the RG 1.60 spectra and the North Anna high frequency spectra, but combined spectra of these two were also used to confirm the design adequacy of the plant. For AP1000 standard design, its CSDRS is raised at 25 Hz with a factor of 1.3 to account for the high frequency content. For the US APWR standard design, its CSDRS adopt the shapes of the RG 1.60 spectra but with the upper limit frequency stretched from 33 Hz to 50 Hz. Since these CSDRS are based on the RG 1.60 spectra, they are different in the horizontal directions and the vertical direction. The EPR CSDRS consist of three spectra for soft, medium, and hard soil conditions, and do not differ between the directions (except for the separate high frequency spectra). The information for the EPR CSDRS is based on the Revision 3 - Interim version of the Final Safety Analysis Report (equivalent to the DCD). The EPR CSDRS were identified as being similar to the RG 1.60 spectra. These design basis spectra are mostly anchored at 0.3 g, with exceptions for the ESBWR HF spectra (at 0.5 g) and for the EPR HF spectra (at about 0.2 g). All these CSDRS are specified at the foundation level except for the AP1000 firm rock and soil site conditions where they are specified at the ground surface.

Figure 3-1 shows the 5%-damped CSDRS for the four new reactor designs in the horizontal directions, and Figure 3-2 shows those in the vertical direction. These two figures also show the generic spectra developed for use in this study, which are essentially the envelope of the various CSDRS with some exceptions at the high frequencies. In the case of the ESBWR, the high frequency content in the CSDRS (dotted lines above 10 Hz) was derived for the North Anna site which is a site-specific case, and thus, was not enveloped. For the EPR, the separate high frequency spectra (not shown in the figures) were not enveloped because those are unique cases and the focus of this SMR study, in its current scope, is not intended to research the effects of the high frequency spectra on the seismic response of structures. Nevertheless, the generic spectra do contain some high frequency content based on enveloping the spectra from the AP1000 and the stretched US APWR CSDRS. This approach to develop the target

spectra is considered to be appropriate because this study is intended to be a generic study not site-specific, and therefore, the goal is to develop broadband generic spectra that would be suitable for most potential sites in the US, not every site. On this basis there is no right or wrong generic broadband spectra, but the more broad the spectra is, the more likely the results of this study could be applicable to various locations in the US. However, the more broad the spectra, the resultant seismic demand to the structure becomes less representative of any particular site and the structure model could be overly driven by the synthetic seismic motions that match the broadband spectra.

For the horizontal directions shown in Figure 3-1, the generic (envelop) spectrum consists of three parts that represent the RG 1.60 spectrum in the lower frequency range (0.2 - 3.5 Hz) used in the ESBWR, AP1000, and US APWR; the EPR spectra for soft, medium, and hard soils in the medium frequency range (3.5 – 25 Hz), and US APWR stretched RG 1.60 spectrum in the higher frequency range (25 – 50 Hz). The generic (envelop) spectrum for the vertical direction has three parts as well, which are very similar to the horizontal envelop spectrum but with the EPR spectra dominating a broader frequency range (0.62 – 25 Hz). For time history synthesis, a frequency range of 0.1 to 100 Hz was considered, requiring the time increment to be a maximum of 0.005 s. The peak spectral accelerations for the horizontal directions and the vertical direction are 0.94 g and 0.9 g, respectively; otherwise, the spectra for the horizontal directions and that for the vertical direction are very similar. Following the CSDRS, the generic spectra are also anchored at 0.3 g PGA.

Most CSDRS were specified at the foundation level (bottom of basemat). In this study, the foundation structure is fully embedded and considers various depth permutations. In addition, the embedment depths are generally greater than those for the new standard designs. For consistency in this study, the generic spectra are specified at the ground surface. This specification satisfies the current SRP 3.7 criteria as long as the top layer soil is competent, i.e. the in-situ soil having a minimum shear wave velocity of 1,000 fps. In the analysis plan as described in Section 2, the soil profiles were proposed to have shear wave velocities ranging from 1,000 fps to 3,000 fps.

The applicants of the new light water reactors have used various methods and computer codes to synthesize the acceleration time histories that match their CSDRS, with a time step of either 0.01 second or 0.005 second and a duration of 20 seconds or slightly longer. The development of synthetic acceleration time histories by the applicants appeared to favor the SRP 3.7.1 Option 1, Approach 2, which requires denser frequency points in the response spectrum calculation but does not usually involve the comparison to power spectral density (PSD). In fact, for an input spectrum that is not the same as the RG 1.60 spectra, the target PSD needs to be defined and justified. As for the acceptance criteria for synthetic acceleration time histories, SRP 3.7.1 and RG 1.208 Appendix F are nearly identical, with just a few minor differences.

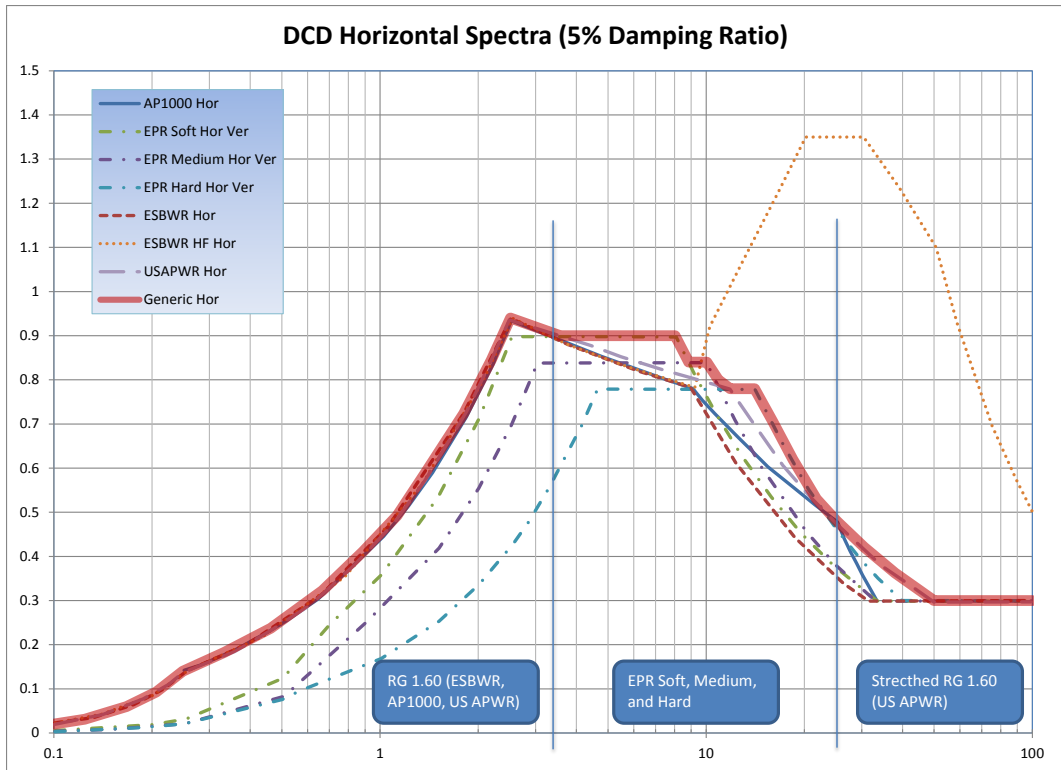

Figure 3-1 Horizontal 5%-Damped Response Spectra

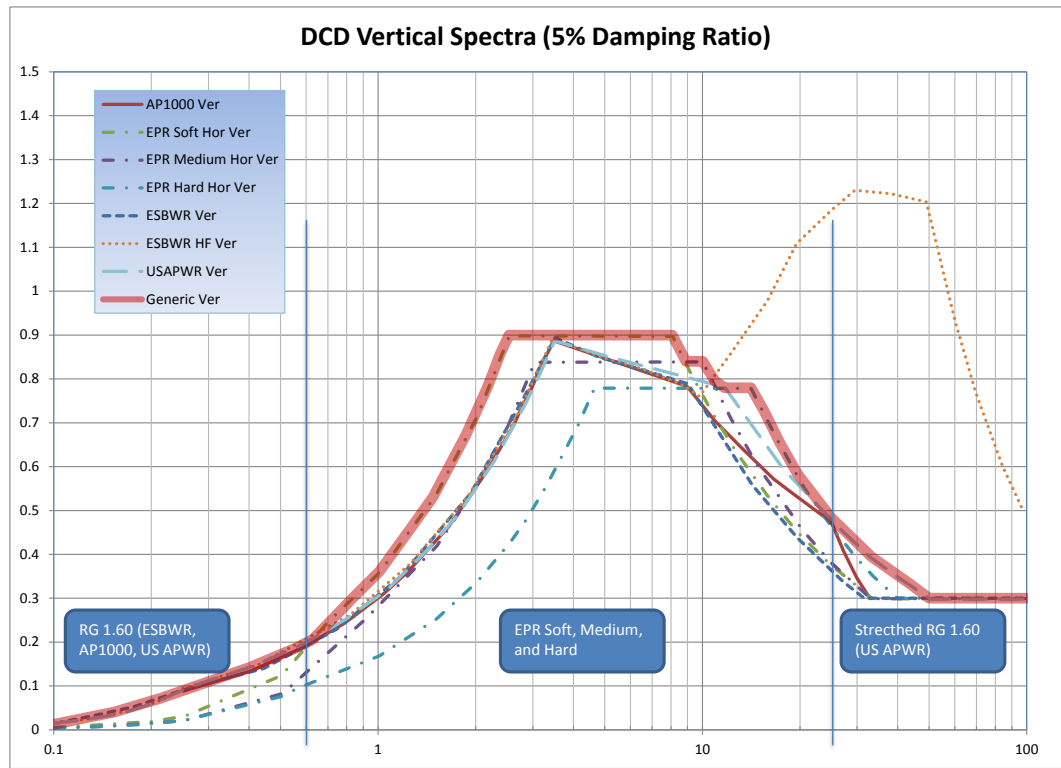

Figure 3-2 Vertical 5%-Damped Response Spectra

Table 3-1 Summary of CSDRS for the New Light Water Reactor Designs

	ESBWR	AP1000	EPR	US APWR
Basis	RG 1.60 and North Anna (HF), considered separately in design, but checked with enveloped spectra	RG 1.60 augmented at 25 Hz with a factor of 1.3	EUR soft, medium, hard (claimed to be similar to RG 1.60) Separate HF	Modified RG 1.60, stretched from 33 Hz to 50 Hz
Hor/Ver Difference	Yes	Yes	No (yes for HF)	Yes
Frequency Range (Hz)	0.1 – 33 (100 for HF)	0.25-33	0.1-50	0.1-50
PGA (g)	0.3 (0.5 for HF)	0.3	0.3 (0.21 and 0.18 for HF horizontal and vertical)	0.3
CSDRS Location	Foundation level	- Foundation level at hard rock sites - Finished grade at firm rock and soil sites	Foundation level	Foundation Level
Time History Duration (s)	22	20	20.48 (30 for HF)	22.005
Synthetic TH Δt	0.01	0.01 (0.005 by linear interpolation for fixed base mode superposition analysis)	0.005	0.005
Synthetic Criteria	- RG 1.92 (Statistically independent) - SRP 3.7.1 Rev 2 PSD approach - NUREG/CR-5347	- RG 1.92 (Statistically independent) - PSD is modified for frequency larger than 9 Hz.	SRP 3.7.1 RG 1.208	SRP 3.7.1
Code for Synthesis			CARES, SIMQKE	RSPMatch (Abrahamson), SPECTRA (for spectra)
Soil Profiles	<ul style="list-style-type: none"> • 4 uniform half space • 4 layered 	6	5 for EUR and 3 for HF motions	8 initial profiles

3.2 Generation of Input Acceleration Time Histories

According to the analysis plan, both one directional and multi-directional inputs will be applied in the analyses. Therefore, a set of three acceleration time histories were generated for the two horizontal directions and the vertical direction. In cases where only one directional input will be needed, one of the two synthetic horizontal components can be used.

The analysis plan also states that if any nonlinear effects are deemed significant enough for evaluation, multiple sets of time history records will be used, in accordance with the guidance in SRP 3.7. At this point, since the potential nonlinear effects have not been determined, the additional sets of time histories have not been developed. As described later in this section, the algorithm in P-CARES for developing synthetic time histories was adapted and enhanced to meet the current NRC regulatory guidance. This enhanced algorithm was automated somewhat in order to permit developing any additional sets of time histories later if needed.

3.2.1 Determination of Seed Records

It is generally believed that the better a seed record matches the target spectrum, the more accurately the resultant synthetic time history matches the same target spectrum. To obtain good seed records for the development of synthetic time histories, the PEER Strong Motion Database (PSMD) was utilized to take advantage of its capability to determine real earthquake records that best match a given response spectrum by linear-scaling. This database is web-based, interactive, and freely accessible, and has more than 10,000 records from 173 worldwide earthquakes that have magnitudes in the range of 4.3 to 7.9.

The major criterion for spectral matching in the PSMD is the weighted mean squared error (MSE) between the response spectrum of a record and the target spectrum. For this study, the weight function was specified as a unity function between 0.1 Hz and 50 Hz. The PSMD retrieves the first 30 earthquake events that best match the target spectrum. After downloading these 30 earthquakes, it was found that the PSMD selection criterion was based on the geometric mean of the two horizontal response spectra, which does not necessarily indicate a best match between any of the two horizontal directions and the target. Therefore, a comparison of the response spectrum of each individual direction and the target spectrum was performed to determine the best match among the individual records using a similar MSE criterion. It was shown that the fault parallel component of NGA180 (Imperial Valley-06, El Centro Array #5 station, 1979), among all the 30 events, best matches both the horizontal and vertical target spectra. In contrast, the original best match reported by PSMD was NGA169 (Imperial Valley-06, Delta station, 1979) because it utilized the geometric mean of the two horizontal components to select the best match. The NGA180 response spectra corresponding to the fault normal (FN), fault parallel (FP), and vertical (V) directions were obtained from the PSMD and are shown in Figure 3-3 through Figure 3-8, along with the target response spectra used for selection of the best real earthquake records. It should be noted that the downloaded PSMD scaled motions are the rotated versions (FN & FP) of the original records (X and Y).

Although the spectra in the FN and vertical directions do not match the target spectra as good as in the FP direction, all three NGA180 records (FP, FN, and V) were still selected as the seed records because the phase spectra of the seeds are of more importance than the amplitude spectra. The correlation coefficients between FP and FN, FP and Vertical, and FN and Vertical were calculated to be -0.031, 0.045, and 0.007, respectively; thereby satisfying RG 1.92 criteria for statistical independence of the

perpendicular earthquake motions. Each of the original NGA180 records has 7857 data points and a time increment of 0.005 seconds, resulting in a total duration of 39.285 seconds, which greatly exceed the requirement of the SRP. Since there will be many SSI analyses, corresponding to the various permutations, a shorter duration is preferable for computational efficiency. To this end, the seed records were truncated at the end to 20.48 seconds (equivalent to 4096 data points). As shown in Figure 3-9, the three components of NGA180 show little vibrations after 20 seconds, therefore, truncating the records to 20.48 second long would not change much the characteristics of the records. The correlation coefficients of the truncated records were calculated to be -0.031, 0.044, and 0.006, respectively, which are nearly identical to the original records.

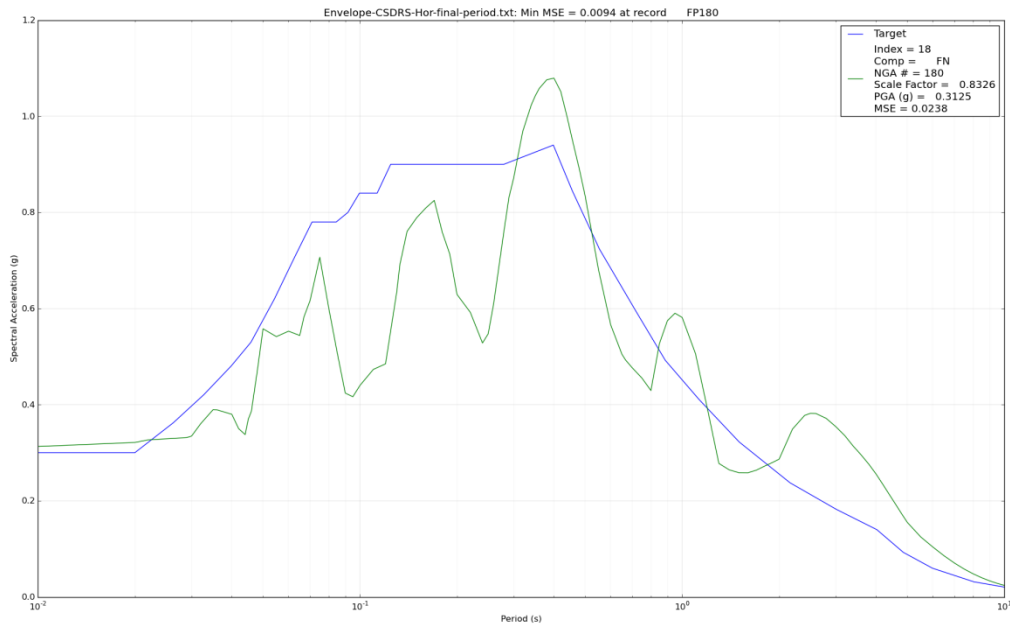

Figure 3-3 Comparison of NGA180 Fault Normal Direction and Horizontal Envelop Spectrum

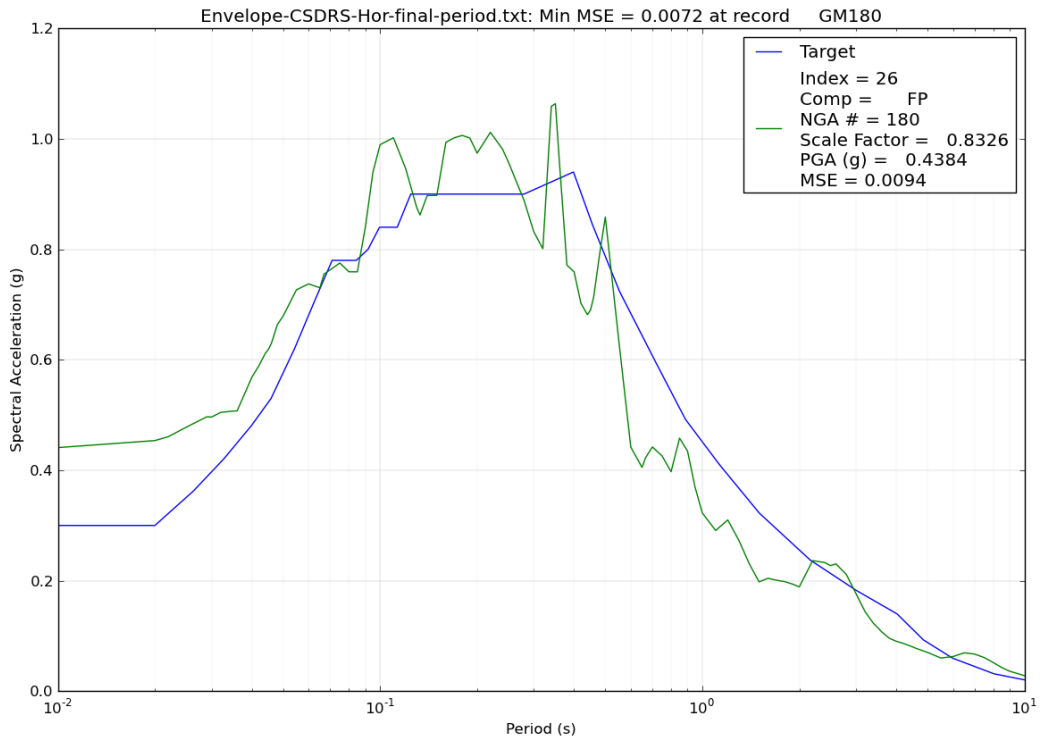

Figure 3-4 Comparison of NGA180 Fault Parallel Direction and Horizontal Envelop Spectrum

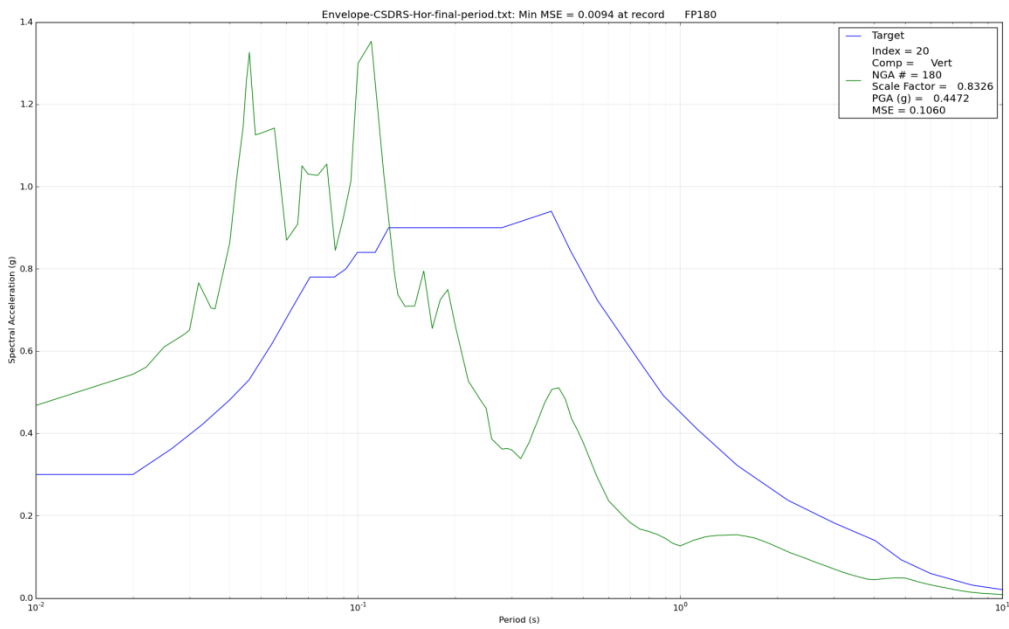

Figure 3-5 Comparison of NGA180 Vertical and Horizontal Envelop Spectrum

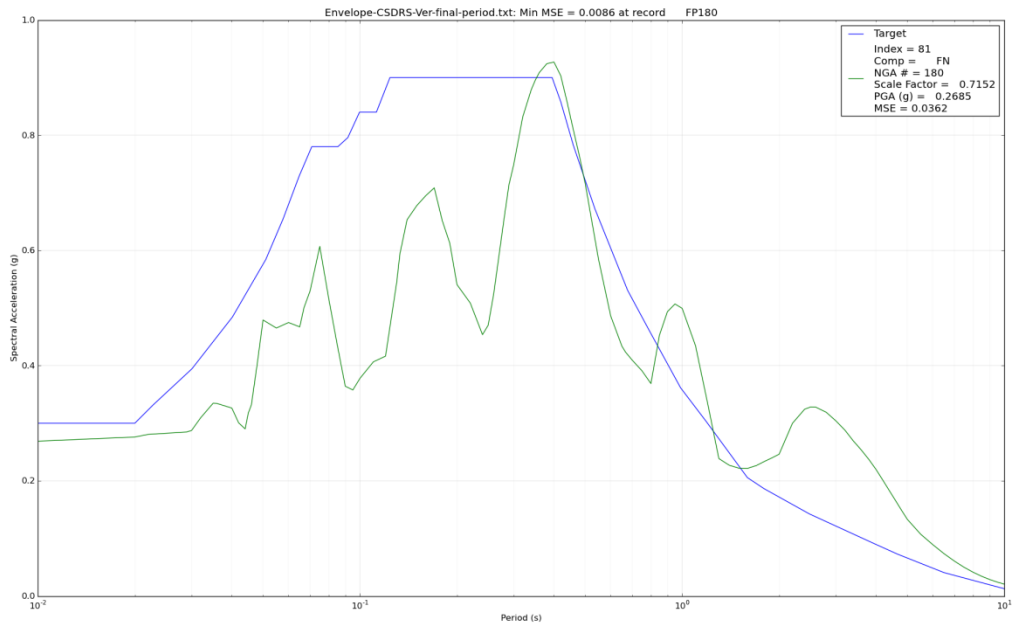

Figure 3-6 Comparison of NGA180 Fault Normal Direction and Vertical Envelop Spectrum

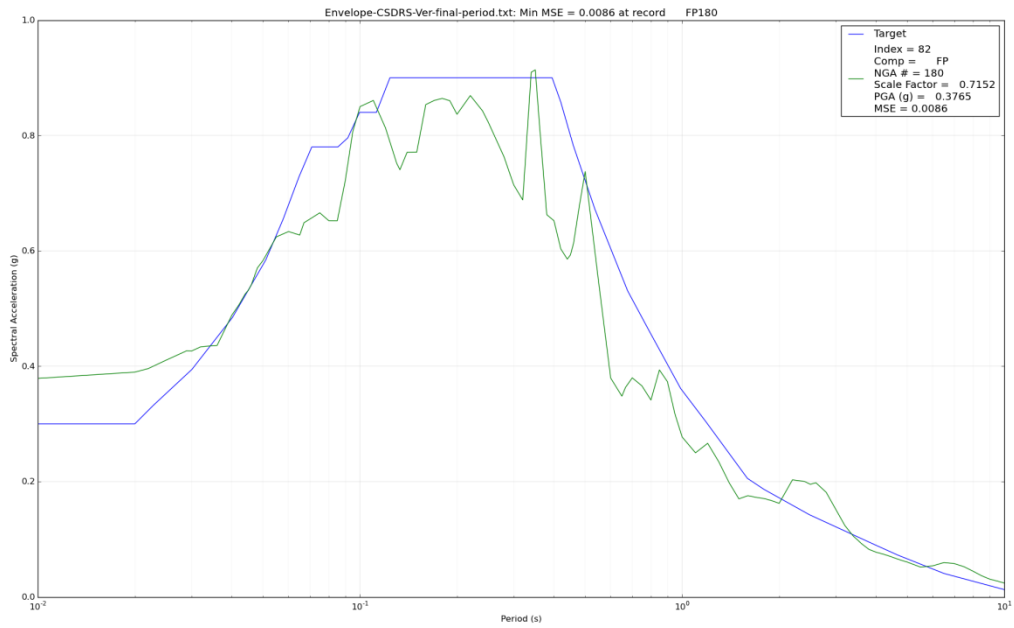

Figure 3-7 Comparison of NGA180 Fault Parallel Direction and Vertical Envelop Spectrum

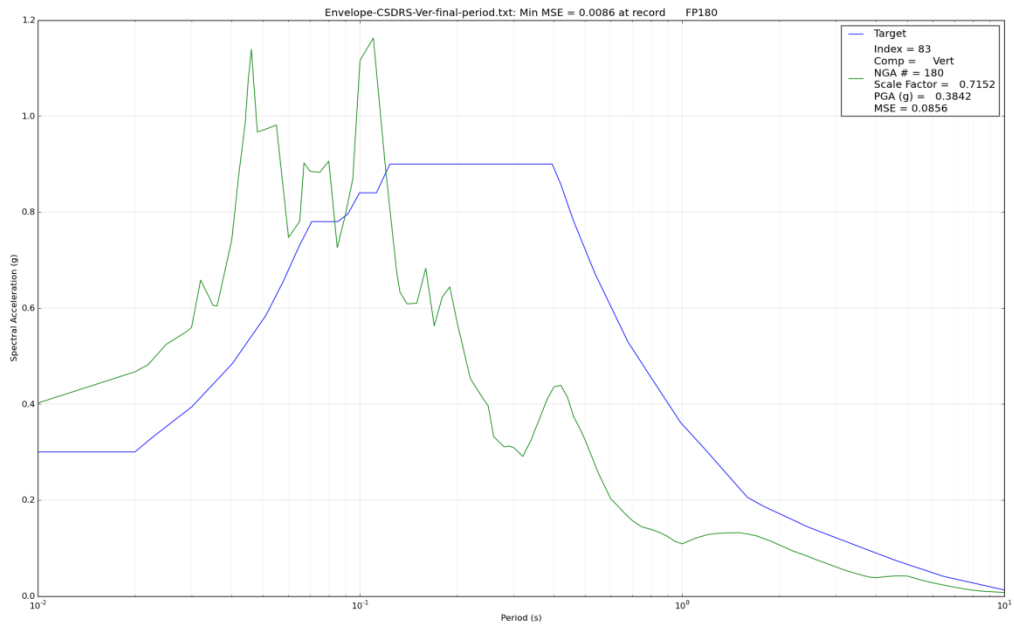

Figure 3-8 Comparison of NGA180 Vertical Direction and Vertical Envelop Spectrum

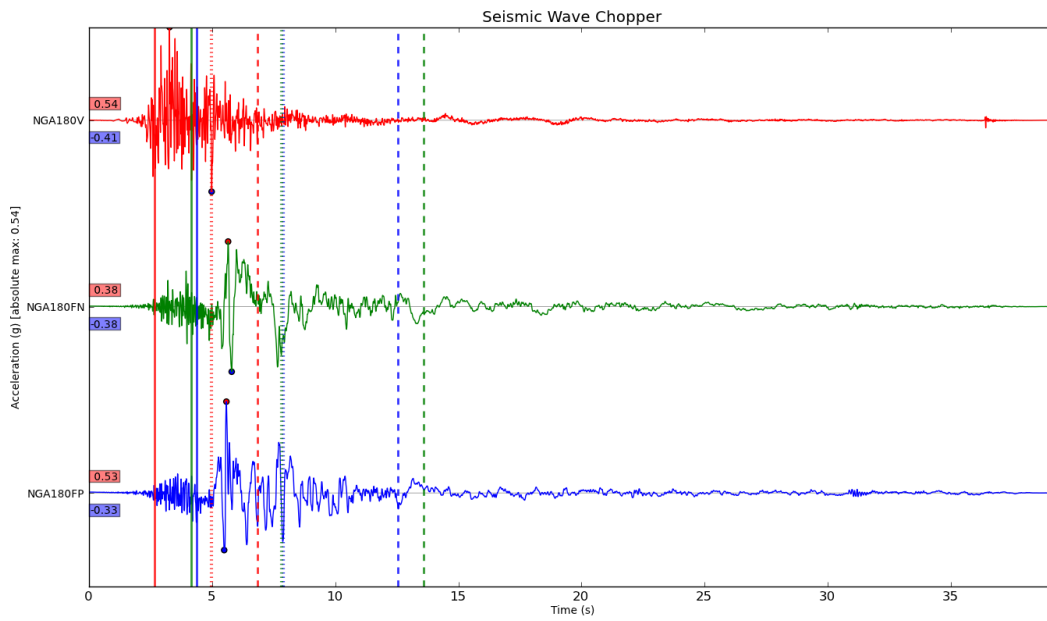

Figure 3-9 NGA180 Wave Forms before Chopped

3.2.2 Generation of Synthetic Acceleration Time Histories

There are generally three approaches to seed-based synthesis of acceleration time histories that match a target response spectrum: (1) frequency domain method (e.g., P-CARES), (2) random vibration theory (RVT) method (e.g., SIMQKE), and (3) time domain method (e.g., RSPMATCH). Although the first approach was readily available in P-CARES, it was found that P-CARES uses the old criteria for spectral matching that is not compatible with SRP 3.7.1 Option1, Approach 2 and RG 1.208 Appendix F. As for approach 2, a copy of SIMQKE was obtained and assessed, and was determined not suitable for this study because (a) it does not accept a seed record without modification of the code, and (b) modification of the SIMQKE code for this study seems to be difficult since an initial attempt to compile the code identified errors on the computer used for this study. For approach 3, the most recent revision of the RSPMATCH program appeared to be available based on a recent paper by Atik and Abrahamson [*Earthquake Spectra*, **26**(3), 601-617]. A copy of the most recent RSPMATCH was obtained but running this software requires a careful study of its manual and a benchmark.

Therefore, it was decided to enhance the algorithm in P-CARES, previously developed by BNL, in order to meet the current SRP 3.7.1 and RG 1.208 criteria. This enhanced algorithm was automated to provide a process that is very efficient in terms of both computational time and minimum involvement of user effort. Therefore, generation of other records, if needed in the future for the cases of potential nonlinear analyses, would be straightforward.

The enhanced algorithm combines the frequency domain method and the RVT method. A core subroutine in SIMQKE was adopted to serve as one of the four initiation methods implemented in the new algorithm. Based on the SIMQKE manual, the resultant spectral density function of the RVT method needs to be iteratively improved to match the target spectrum, indicating that the RVT approach in SIMQKE is in fact a frequency domain method enhanced with an RVT initiation method.

The automated process for the enhanced algorithm uses a graphical user interface to show the major characteristics of a record in real time. This process can generate a synthetic acceleration time history, automatically verify it against the SRP/RG criteria, and update the ground motion statistics instantly, which can direct the analyst to perform any additional steps.

Figure 3-10 shows the original seed record NGA180 FP, which is used for generating the first horizontal record for the SMR study (SMR_H1). The left-hand side plot is for response spectra showing: the target spectrum in solid blue line, the 30% higher and 10% lower bounds in blue and green dotted lines, the response spectrum of the seed record, and the corresponding major statistics of the record at the upper-left corner. The response spectra were calculated at 100 frequency points per frequency decades, evenly distributed in the log scale, per SRP and RG criteria. Equivalently, 301 frequency points were used between 0.1 Hz and 100 Hz. The top three plots on the right hand side show the acceleration, velocity, and displacement time histories. The acceleration plot also shows the points in time for the 5% (T5) and 75% (T75) accumulative Arias intensity (two red bars), the trapezoidal intensity function, and a shape function that is obtained as a moving-average of the absolute values of the acceleration time history. The shape function is used for ZPA correction. The units of the time histories are based on gravity constant g . The two square plots at the bottom of the right hand side show the Fourier amplitude spectrum and the power spectrum as defined in ASCE4-98. The power spectrum curve is smoothed using a $\pm 20\%$ frequency window.

Figure 3-11 shows the resultant SMR_H1 acceleration time history and other quantities in the same interface as in Figure 3-10. The response spectrum of SMR_H1 is within the SRP 90%-130% bounds, and

on average is about 8% higher than the target spectrum. In the frequency range between 0.2 Hz and 25 Hz (actually up to 100 Hz) per RG 1.208, the largest spectral ratio is 1.19 (< 1.3) and smallest spectral ratio is 0.92 (> 0.9). The maximum number of adjacent points below the target spectrum is 4 (≤ 9). At very low frequencies below 0.15 Hz, the response spectrum of SMR_H1 is lower than the target by more than 10%. Generally speaking, this problem was caused by running the high pass filter procedure more times than needed; however, it can be solved by randomizing the record and rerunning a few times any of the three spectral matching methods. This low frequency content at the magnitude shown in this figure is not considered to have any significant effect to this study because nuclear plant structural frequencies are much higher than 0.15 Hz. The strong motion duration of SMR_H1, as defined by T75 - T5, is 6.32 seconds (> 6). The correlation coefficient between SMR_H1 and its seed record is 0.57, indicating a strong correlation, or high similarity between the seed record and the synthetic record.

Figure 3-12 and Figure 3-13 show the seed record NGA180 FN and the synthetic acceleration time history SMR_H2, respectively. Using a target frequency window of 0.2 Hz to 25 Hz per RG 1.208, the average spectra ratio is 1.06 (slightly > 1.0), and the largest and smallest spectra ratios are 1.17 (< 1.3) and 0.97 (> 0.9) respectively. There is only one frequency point in the frequency range of [0.2 Hz, 25 Hz] which has a spectral value smaller than the target spectrum. The strong motion duration is 6.70 s (> 6). The correlation coefficient between SMR_H2 and its seed is 0.71.

Figure 3-14 and Figure 3-15 show the seed record NGA180 V and the synthetic acceleration time history SMR_V, respectively. In the entire frequency range [0.1 Hz, 100 Hz], the average spectral ratio is 1.09, while the largest and the smallest spectral ratios are 1.27 and 0.94, respectively. The maximum adjacent number of frequency points where the spectral values of the SMR_V is lower than the target is 8 (< 9). The correlation coefficient between SMR_V and its seed is 0.4, somewhat lower than the horizontal directions but still greater than the criterion 0.16 which is used to define statistical independence. The low correlation between SMR_V and its seed was expected in the generation process because a few randomization iterations needed to be performed to increase the strong motion duration, which for the seed is only 2.31 seconds.

Finally, the correlation coefficients among SMR_H1, SMR_H2, and SMR_V are calculated to be:

SMR_H1 \leftrightarrow SMR_H2: -0.050 (seeds: -0.031)

SMR_H1 \leftrightarrow SMR_V: -0.022 (seeds: 0.045)

SMR_H2 \leftrightarrow SMR_V: -0.067 (seeds: 0.007),

which demonstrate that the three components are statistically independent (the upper limit is 0.16). Since the correlation coefficients reflect the phase spectra of the records, statistical independency for selection of seed records is a necessary condition because the frequency domain synthesis method or the RVT method using a seed record does not significantly change the phase spectra. The observed minor changes in the correlation coefficients (shown above between the seeds and synthetic motions) are due to the application of the baseline correction, intensity function, and to a lesser extent the ZPA clipping.

Acceleration Time History Synthesis: SMR_H1

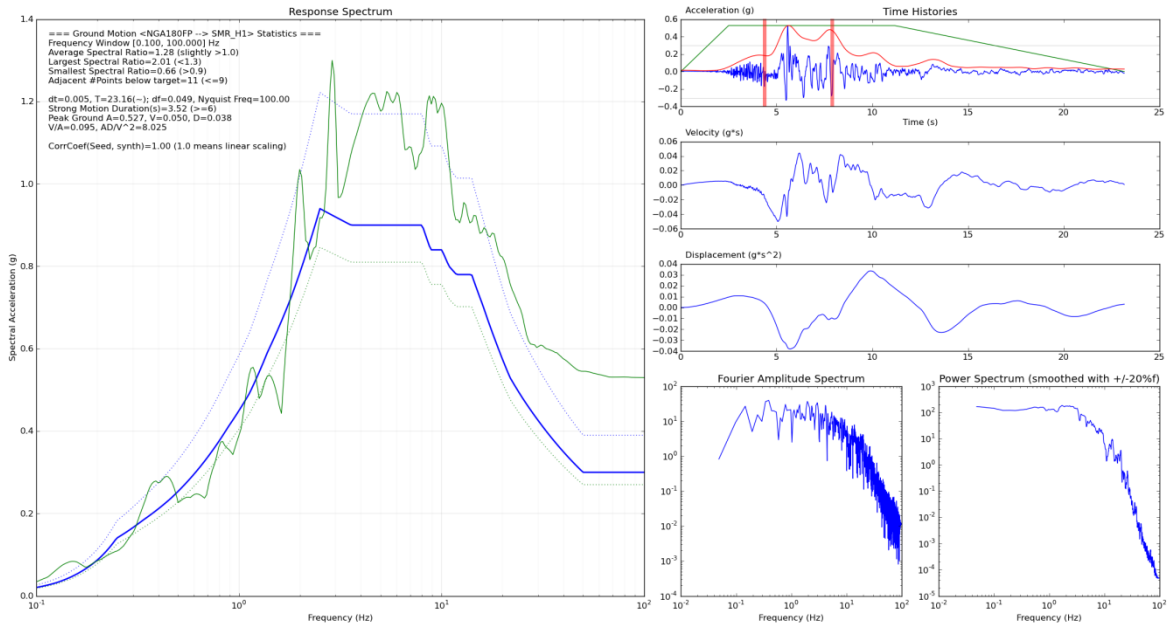

Figure 3-10 Seed Record NGA 180 FP

Acceleration Time History Synthesis: SMR_H1

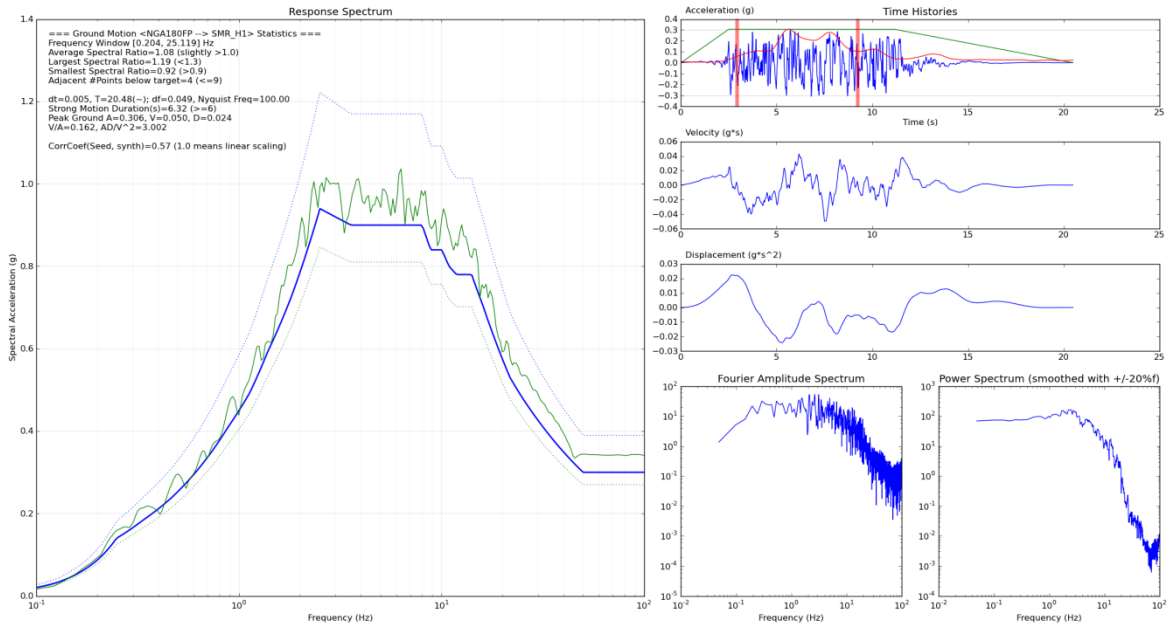

Figure 3-11 Synthetic Record SMR_H1 based on Seed Record NGA 180 FP

Acceleration Time History Synthesis: SMR_H2

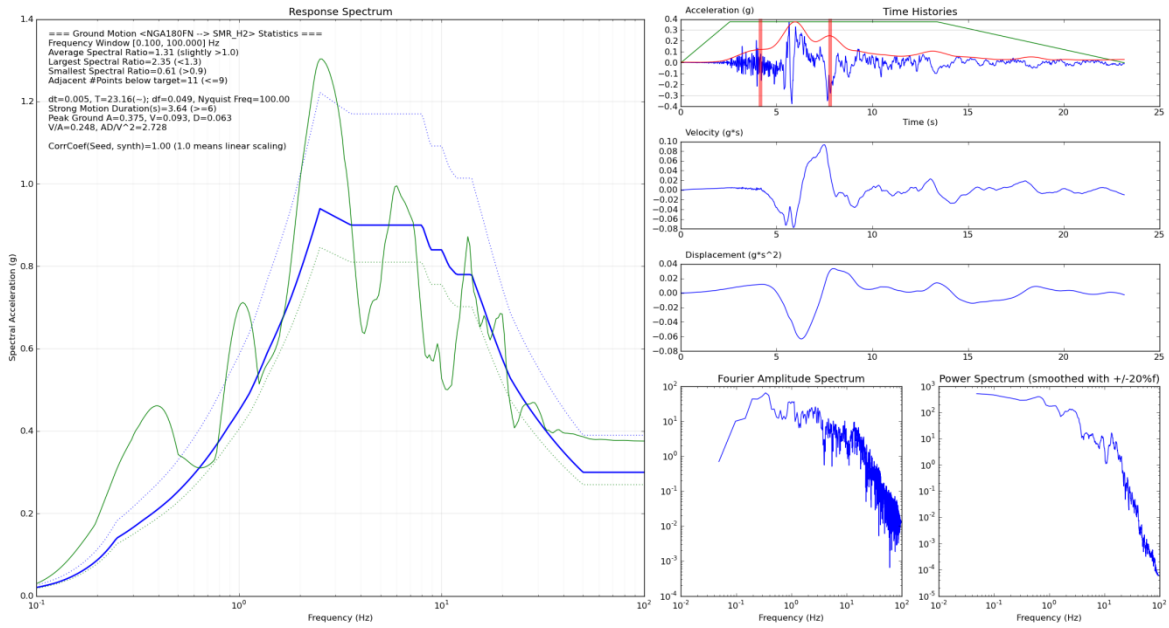

Figure 3-12 Seed Record NGA 180 FN

Acceleration Time History Synthesis: SMR_H2

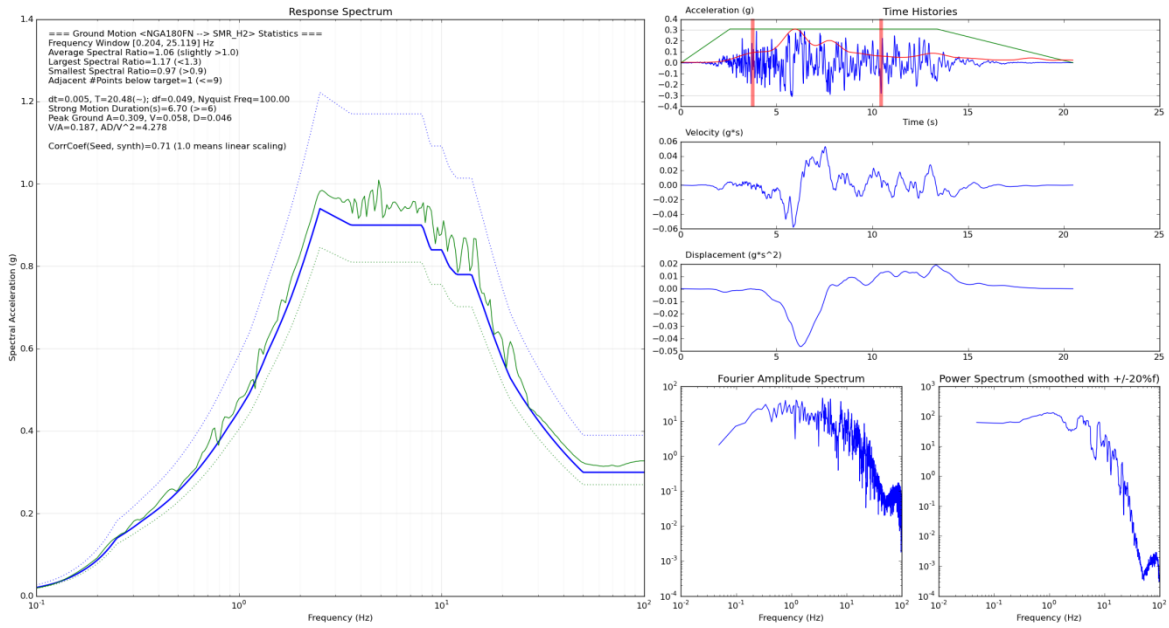

Figure 3-13 Synthetic Record SMR_H2 based on Seed Record NGA 180 FN

Acceleration Time History Synthesis: SMR_V

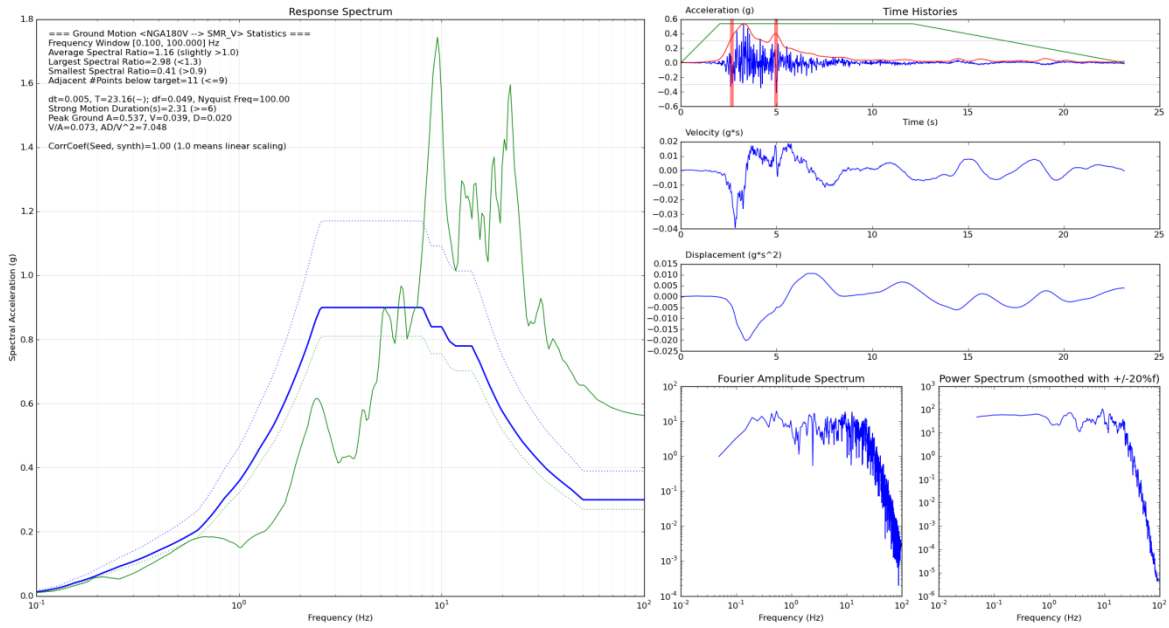

Figure 3-14 Seed Record NGA 180 V

Acceleration Time History Synthesis: SMR_V

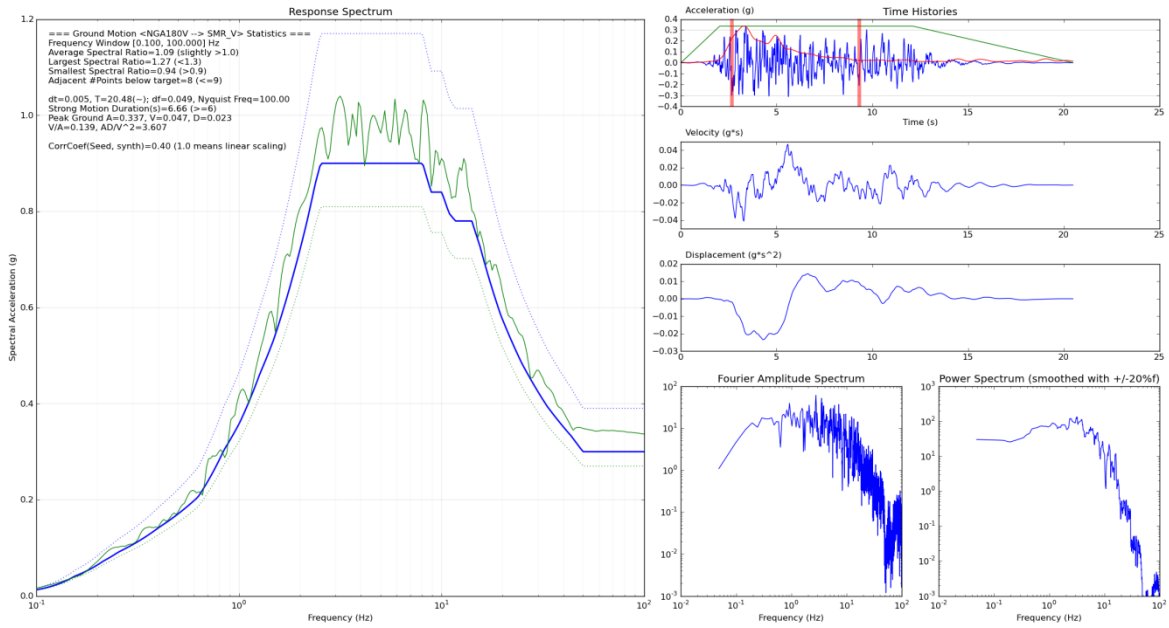

Figure 3-15 Synthetic Record SMR_V based on Seed Record NGA 180 V

4 DEVELOPMENT OF FINITE ELEMENT MODELS

4.1 Development of the ANSYS Model

The development of the SASSI structural and excavated soil models in this study consists of three steps: (1) creating the solid models in ANSYS, (2) meshing of the solid model and addition of the reactor containment and reactor internal structure models, and (3) transforming the ANSYS finite element models (node and element definitions) to SASSI models. The ANSYS code is utilized to create the finite element model, prior to transforming it to SASSI, because ANSYS has a very powerful pre-processor which the available SASSI2000 does not have. The work completed so far includes the development and verification of the mesh distributions for the foundation, containment, containment internal structures (CIS), and excavated soil; ANSYS modal analyses; and the transformation of the ANSYS finite element models (ANSYS CDB files) to SASSI models.

The basic configuration as described in the analysis plan, also shown in Figure 2-1, was the starting point for the development of the finite element model (base model, for short), because all the other permutations, including dimensional changes and layout permutations, can be achieved by minor modifications to the base model. Figure 4-1 shows the ANSYS solid model (before meshing to finite elements) for the foundation structures, which include the perimeter walls, rib walls, and the basemat. The ANSYS solid model for the excavated soil, not shown in this figure, occupies the entire space covered by the perimeter walls and the basemat. The exterior walls/basemat coincides with the corresponding surfaces of the solid excavated soil model, so that the interaction nodes between the foundation and the excavated soil can be generated. During solid modeling, key points were inserted at locations where the containments are attached to the walls and basemat. The containment and CIS are not directly modeled through the ANSYS solid modeling approach, as they can be easily generated directly using beam/mass elements.

Based on the input spectra, a cutoff frequency of 50 Hz was determined for use in deriving the largest element size. Following the SASSI User's Manual, the largest element size in the horizontal directions and the vertical direction was calculated to be 4 ft, using the lowest shear wave velocity of 1000 fps. Figure 4-2 shows the structural finite element model in ANSYS, including the concrete walls and basemat, containment, and CIS. The beam/mass models for the containment and CIS are shown in the model but not distinguishable from each other in the figure because they are coincident and the torsional effects are expected to be minimal. It is expected that the containment/CIS modeling might be changed later. The concrete for the foundation structure is assumed to have a compressive strength of 6000 psi. The properties of the containment and internal structures are estimated based on some recent SMR presentations and will be subjected to adjustment during the ANSYS modal analysis and/or during the SASSI SSI analysis.

The total number of nodes in the structural model is 5813 and the number of shell, beam, and mass elements is 6040. Since the entire foundation is buried, the excavated soil model developed following the guidelines in SASSI manual is very large, resulting in 23040 solid elements. There are 4105 interaction nodes connecting the structural model (foundation walls and basemat) and the excavated soil model. The total number of nodes is 27433.

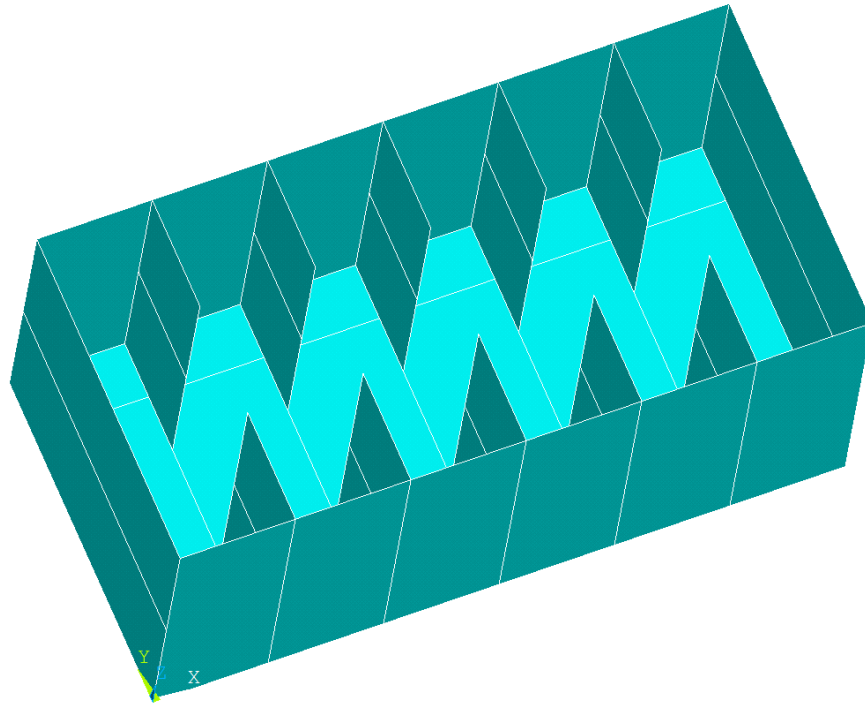

Figure 4-1 ANSYS Solid Model for the Foundation Perimeter Walls, Rib Walls, and Basemat

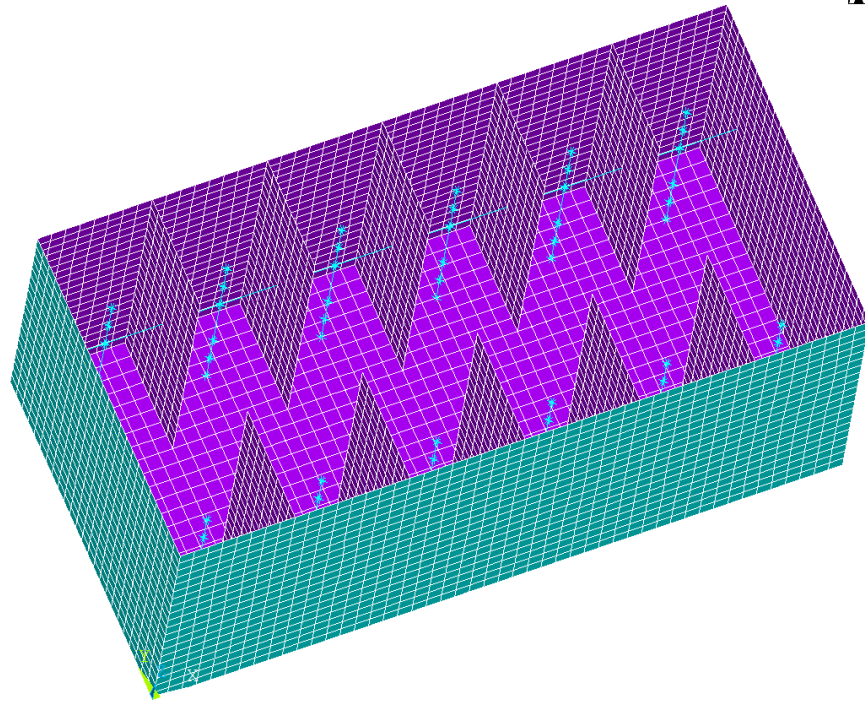

Figure 4-2 ANSYS Finite Element Model (Foundation, Containment, and Internal Structures)

4.2 ANSYS Modal Analysis

The fine structural mesh of the ANSYS model, which may be changed due to the limitation of the model size in SASSI, allows a detailed assessment of its dynamic characteristics. An ANSYS modal analysis was performed to obtain the fundamental frequencies and mode shapes of major modes of the entire model and various components, which can be used in the future to adjust the cutoff frequency and update the finite element model if necessary. Modal analysis can also be used to identify any potential modeling deficiency.

Instead of a fixed base assumption that is commonly used for the modal analysis, the ANSYS modal analysis in this study assumed pinned conditions at the four corners of the basemat. The goal is to identify the modes associated with the basemat, which can have a significant impact on the soil-foundation interaction and structure-containment interactions.

The ANSYS modal analysis included 600 modes to include natural frequencies as high as 128.9 Hz. Figure 4-3 shows the cumulative mass fraction as a function of the natural frequencies for the three translational and three rotational directions up to a frequency of 30 Hz. It is obvious that the major modes of the ANSYS model are those below 17.5 Hz. Therefore, for a better cutoff frequency, any value between 17.5 Hz and 25 Hz can be considered to be adequate to represent the structure model. Of course, a final selection of the cutoff frequency needs to consider the dynamic characteristics of the soil column and the frequency content of input spectra. The fundamental frequency was found to be 2.9 Hz, corresponding to a mode mainly participated by the two long walls (see Figure 4-4).

Figure 4-4 through Figure 4-26 show the selected mode shapes that are considered to be representative of the entire structure and major components. The selected modes include the first 16 modes for frequencies up to 9.9 Hz, and 7 selected higher modes up to a frequency of 25 Hz. It should be noted that the mode shapes usually involve a combination of several structural components. For example, the modes for the containments appear to coexist with large modal deformation in the walls and basemat. The natural frequencies for any particular component are difficult to identify without additional modal analyses with appropriate boundary conditions strictly applied at that component. In particular, a distinguishing mode for the basemat was not identified because of the strong support from the perimeter walls and the rib walls. From the mode shapes, the rib walls appear to be very important in ensuring an adequate stiffness for the relatively large and thin perimeter walls and basemat. In summary, the first 64 modes have natural frequencies in a range of 2.9 Hz to 25 Hz, which is considered reasonable for a typical soil column to resonate with the structure model.

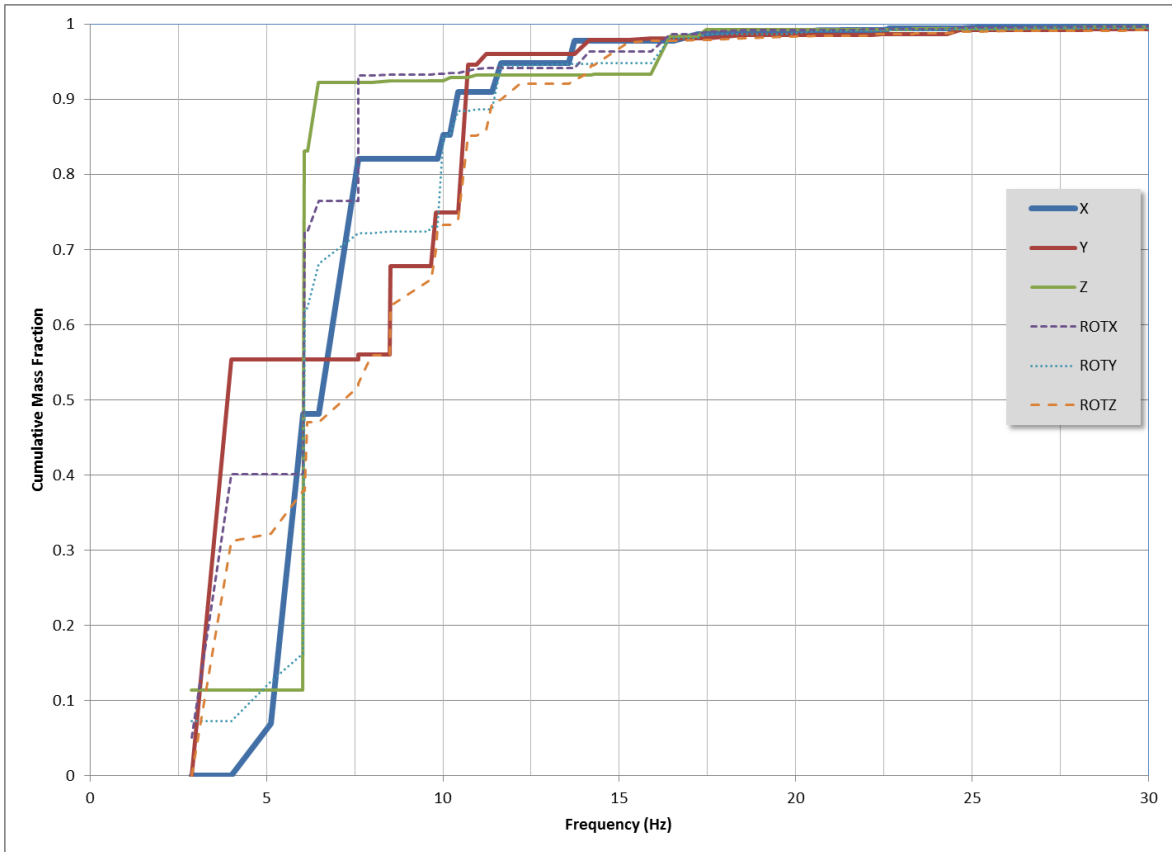

Figure 4-3 Cumulative Mass Fraction

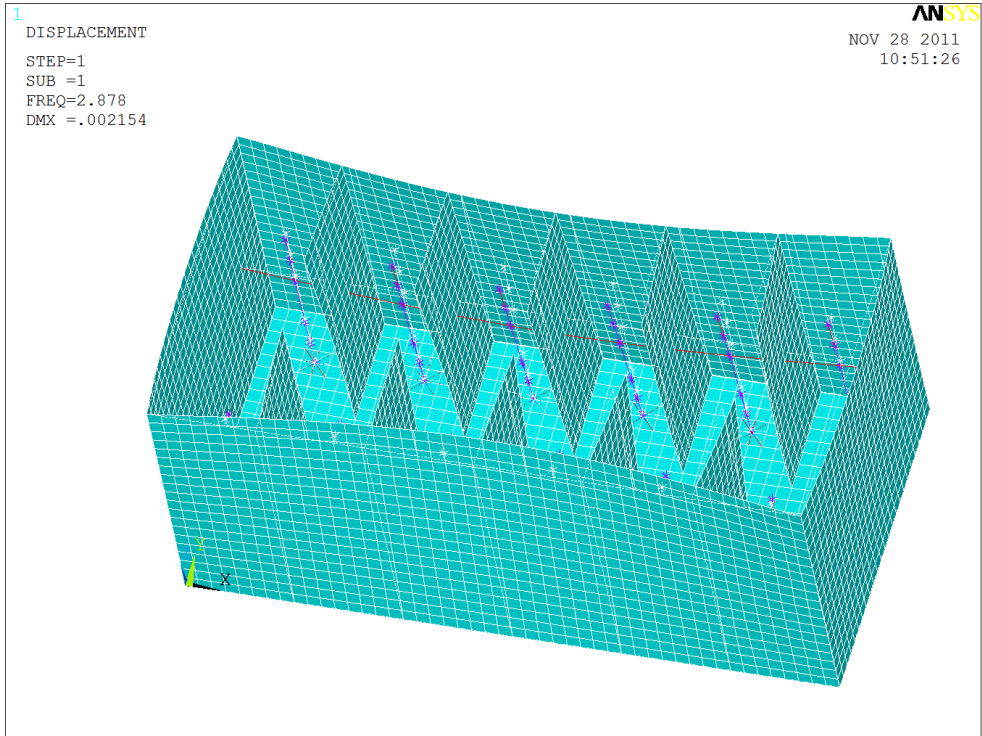

Figure 4-4 Mode Shape 1: Long Wall

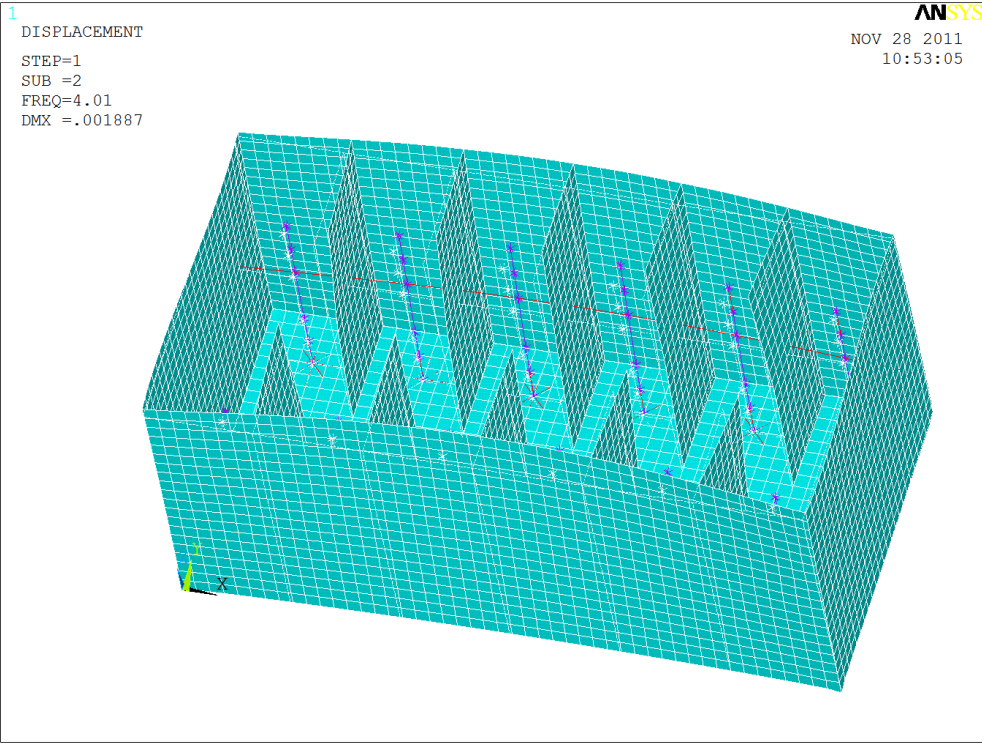

Figure 4-5 Mode Shape 2: Entire Model along Short Edge

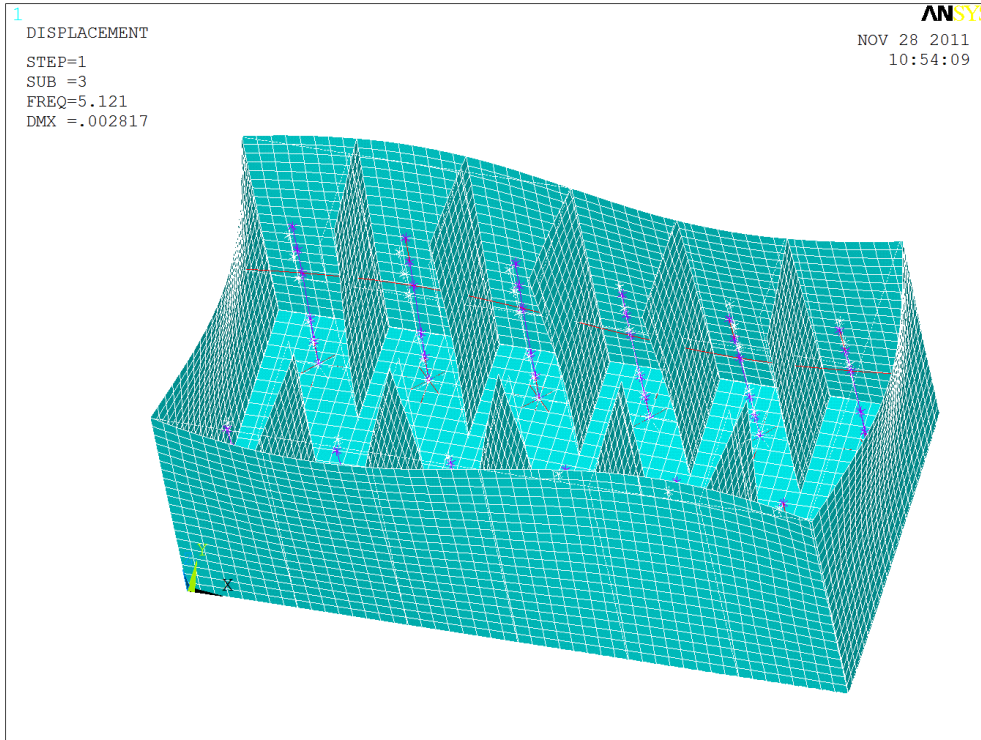

Figure 4-6 Mode Shape 3: Short Wall (1st mode) and Long Wall (2nd Mode)

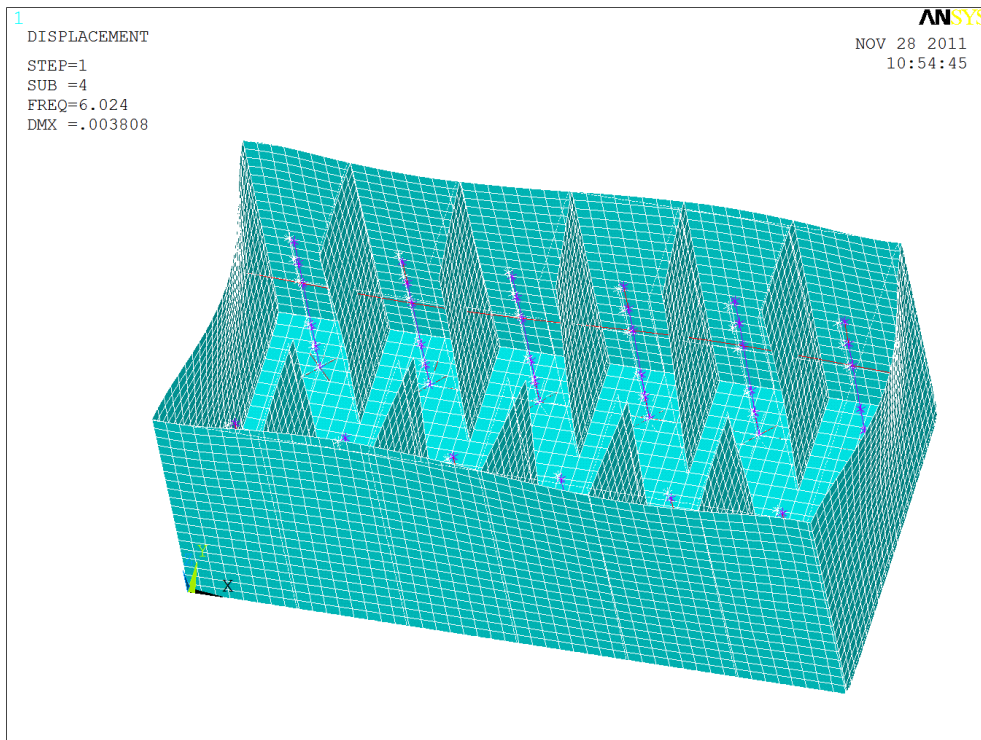

Figure 4-7 Mode Shape 4: Short Wall (1st mode) and Long Wall (2nd Mode) in Reverse Order

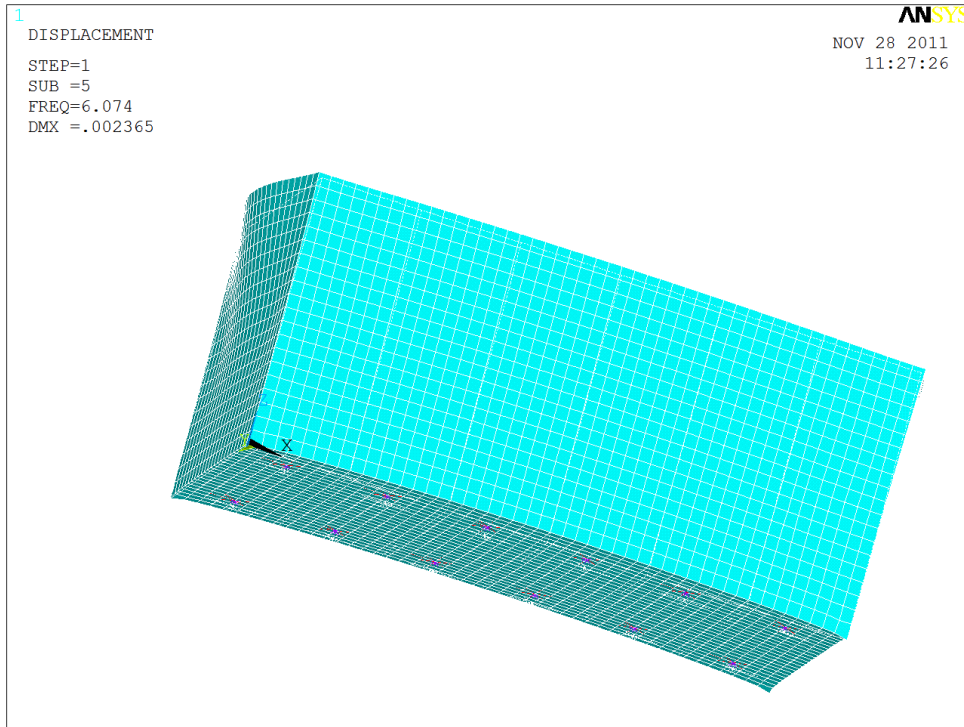

Figure 4-8 Mode Shape 5: Short Wall (1st mode) and Basemat

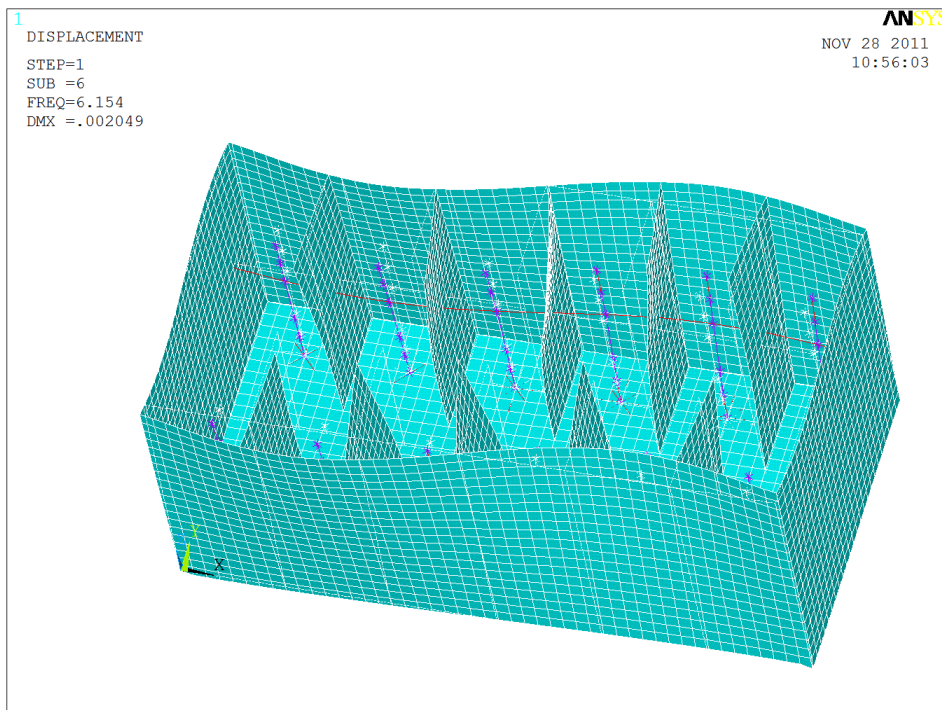

Figure 4-9 Mode Shape 6: Long Wall (2nd Mode)

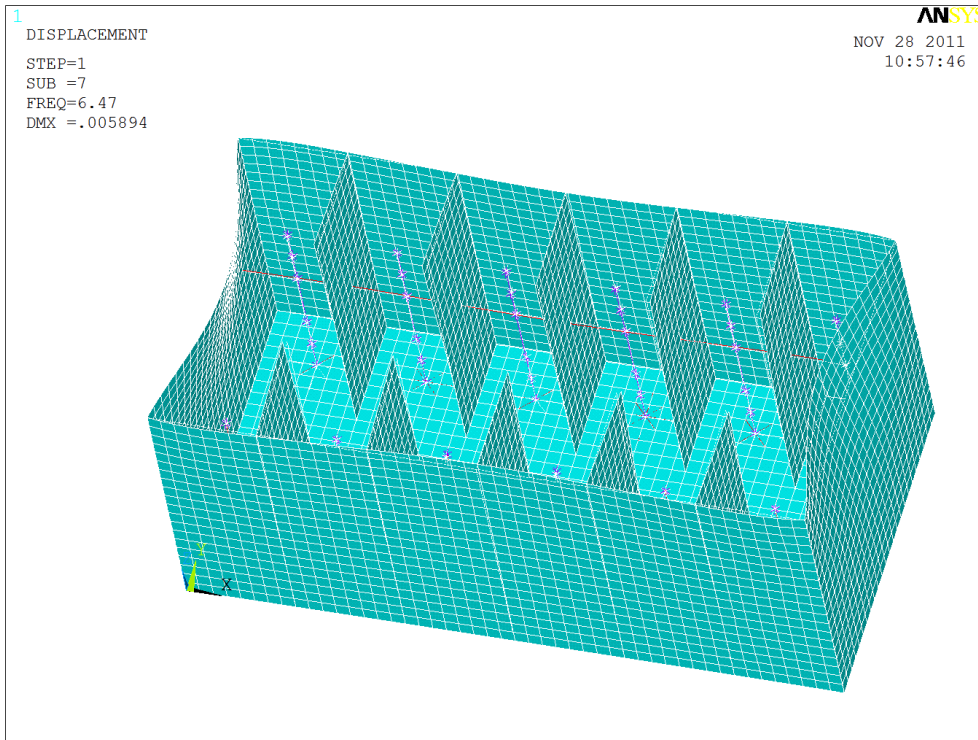

Figure 4-10 Mode Shape 7: Short Walls

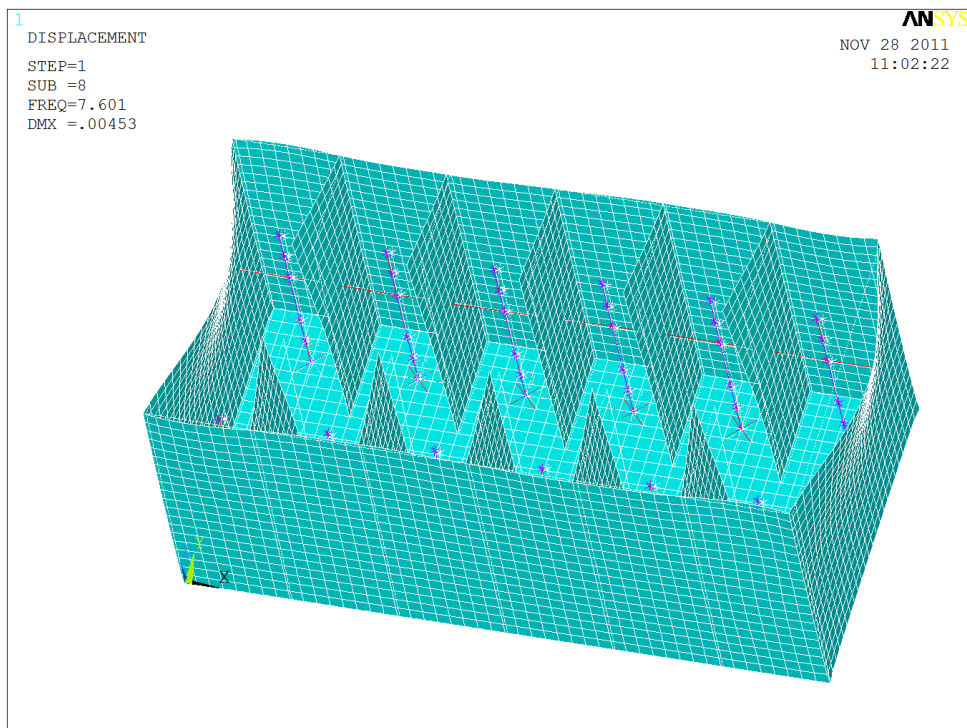

Figure 4-11 Mode Shape 8: Short Walls and Rib Walls

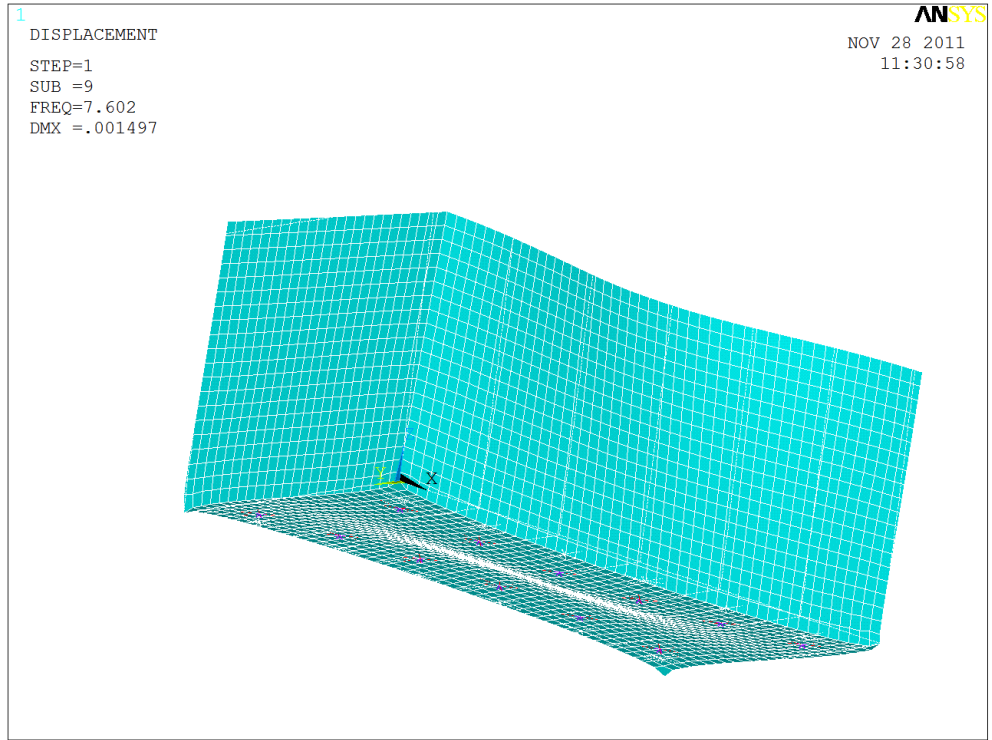

Figure 4-12 Mode Shape 9: Long Wall and Basemat

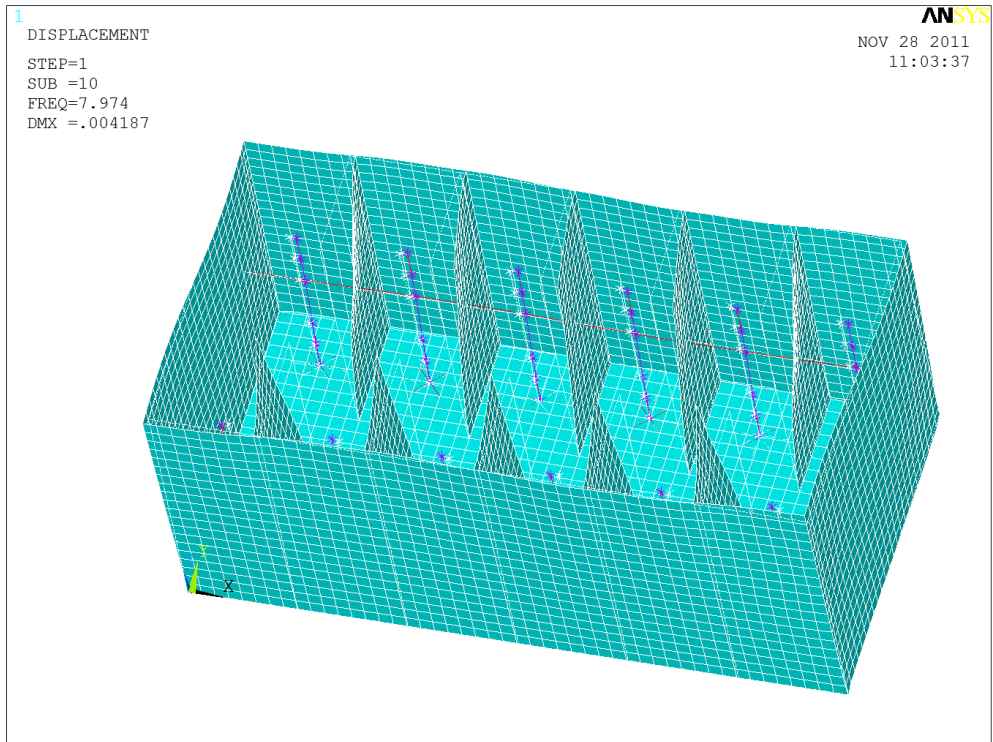

Figure 4-13 Mode Shape 10: Rib Walls

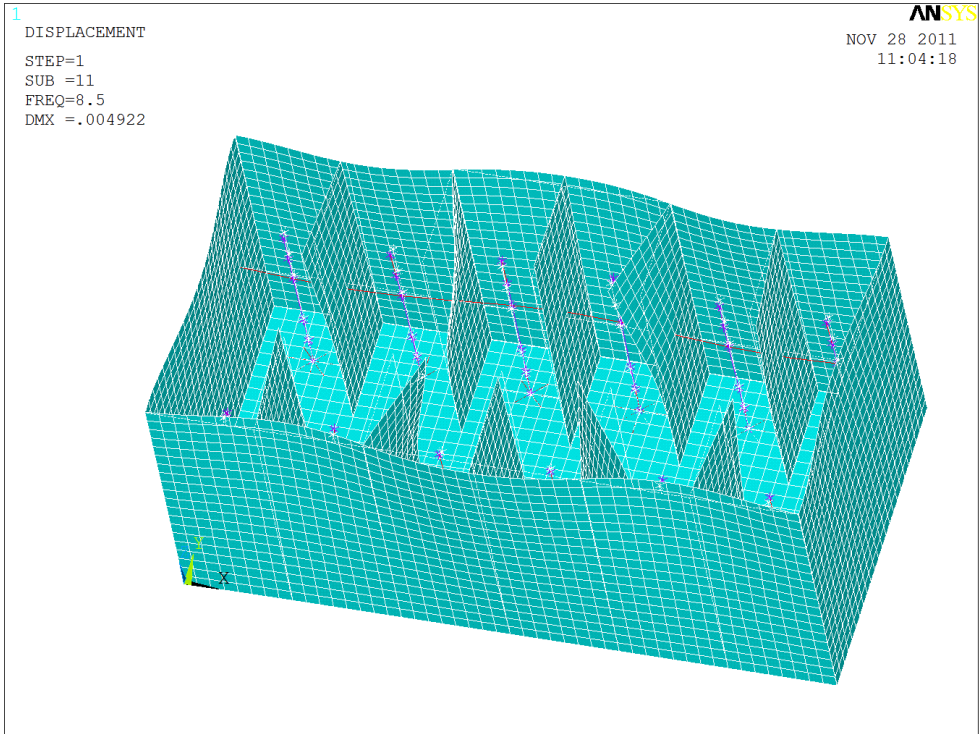

Figure 4-14 Mode Shape 11: Long Walls (3rd Mode), Short Walls, and Rib Walls

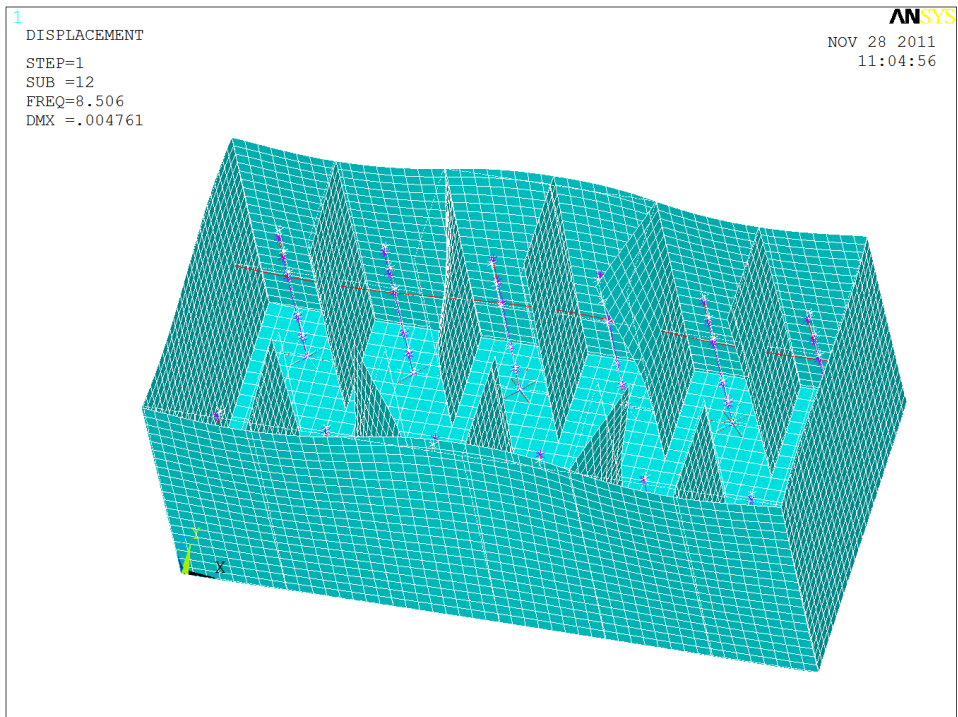

Figure 4-15 Mode Shape 12: Long Walls (3rd Mode) and Rib Walls

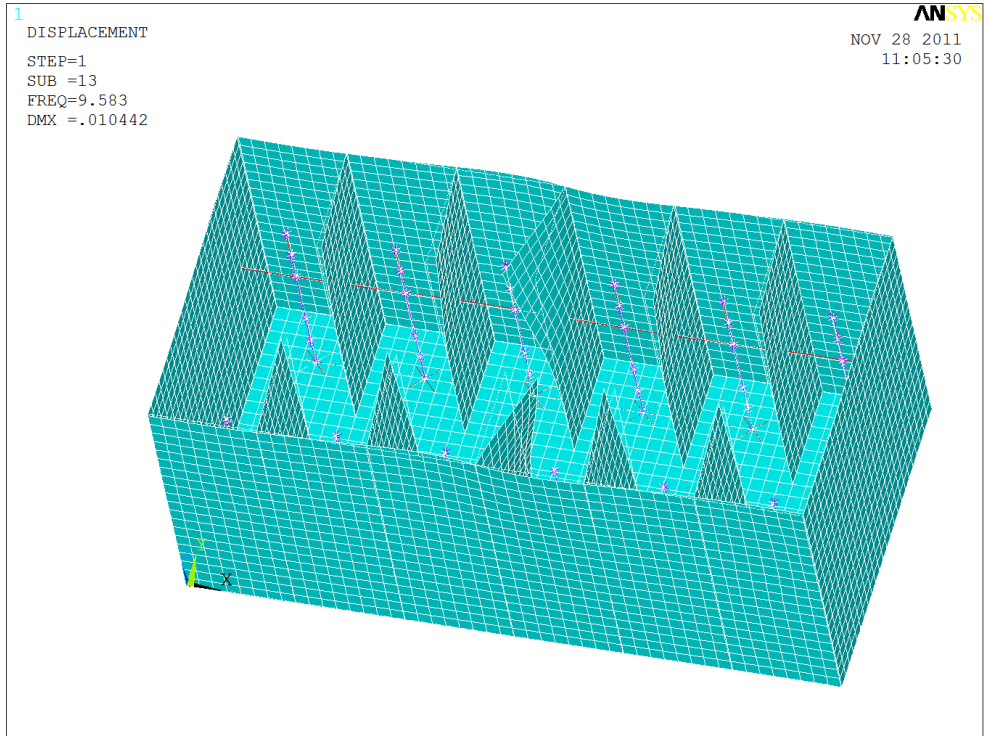

Figure 4-16 Mode Shape 13: Rib Walls (1)

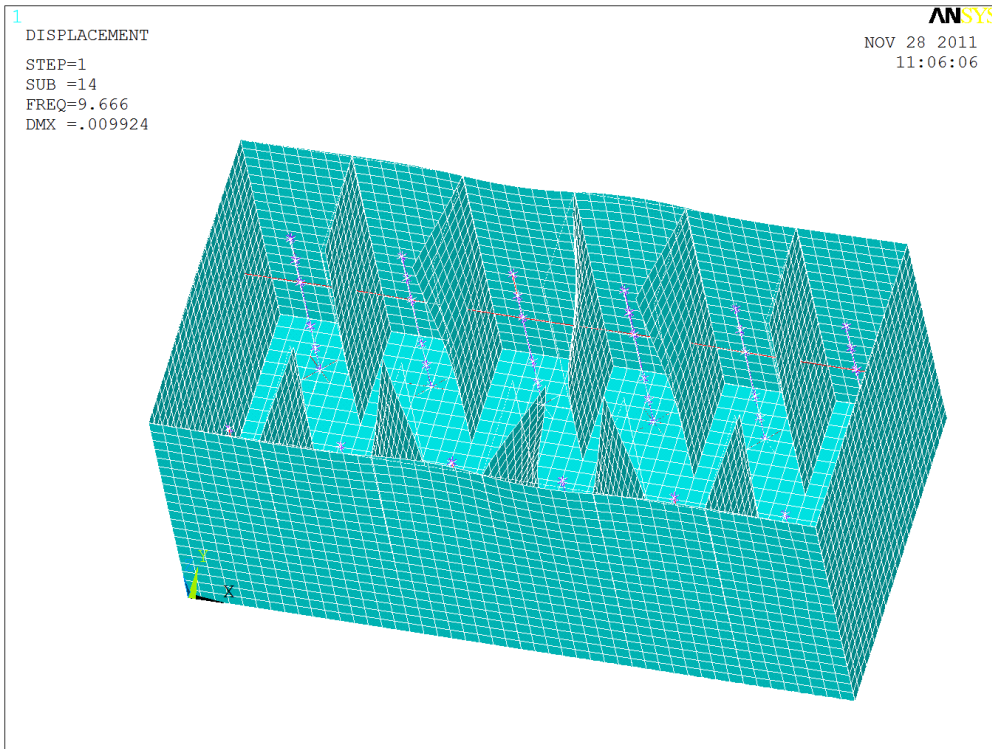

Figure 4-17 Mode Shape 14: Rib Walls (2)

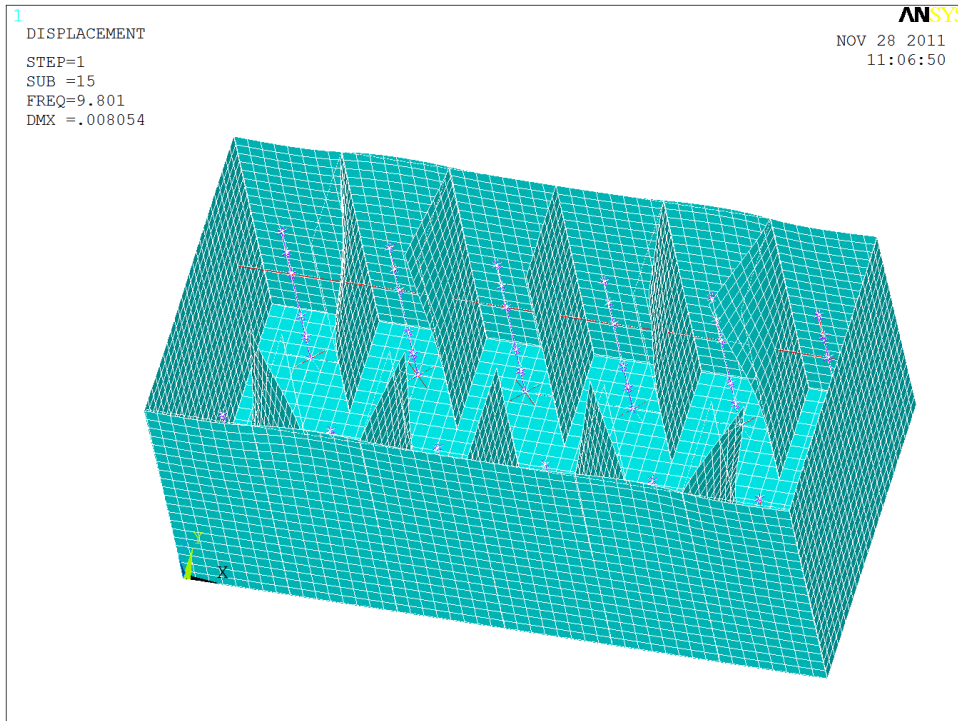

Figure 4-18 Mode Shape 15: Rib Walls (3)

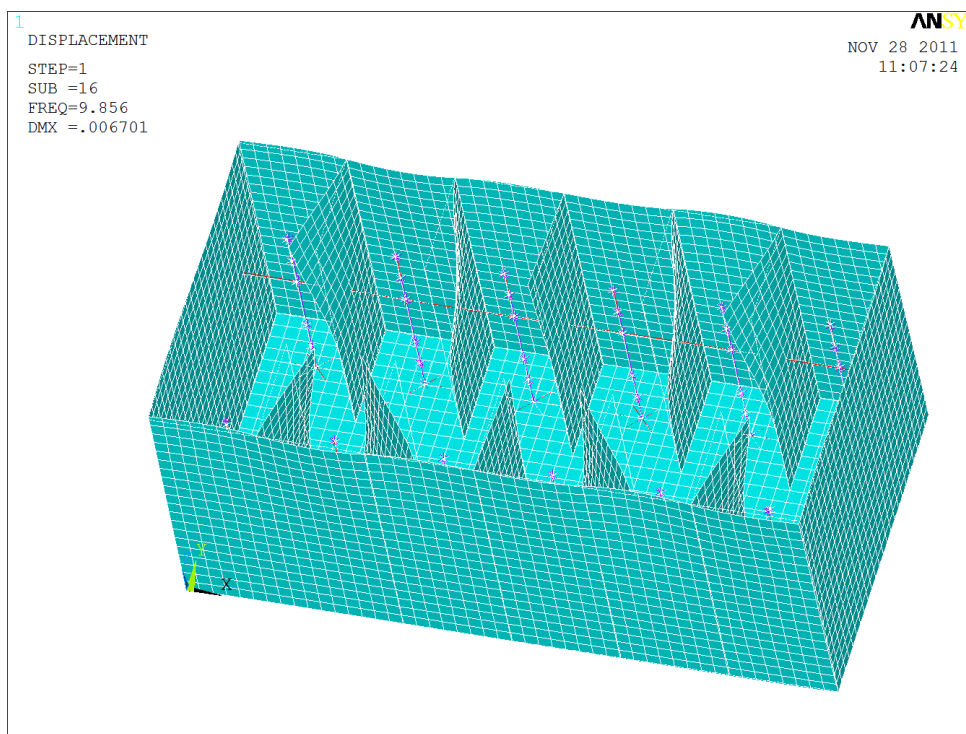

Figure 4-19 Mode Shape 16: Rib Walls (4)

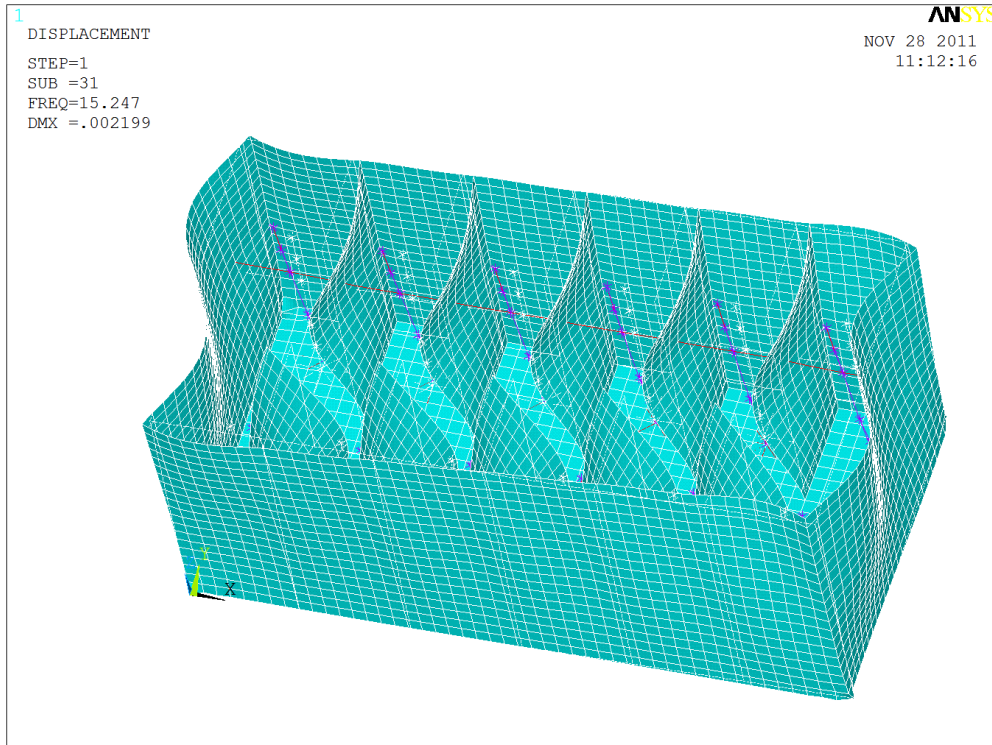

Figure 4-20 Mode Shape 31: Short Walls (2nd Mode), Rib Walls, and Containments

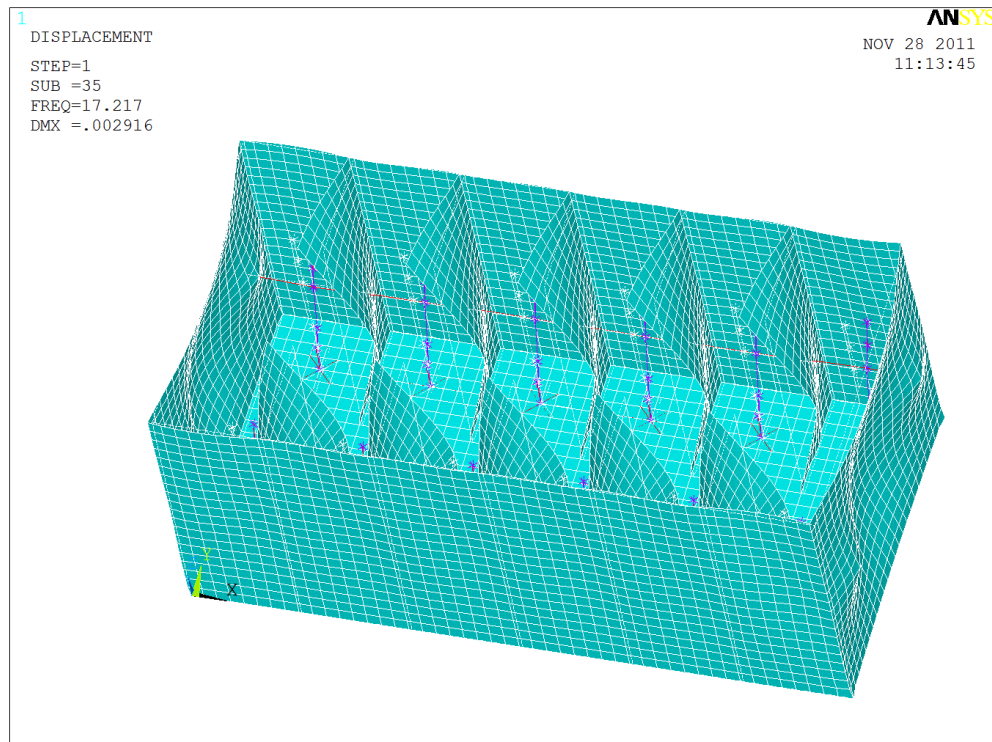

Figure 4-21 Mode Shape 35: Short Walls, Rib Walls, and Containments (Higher Mode)

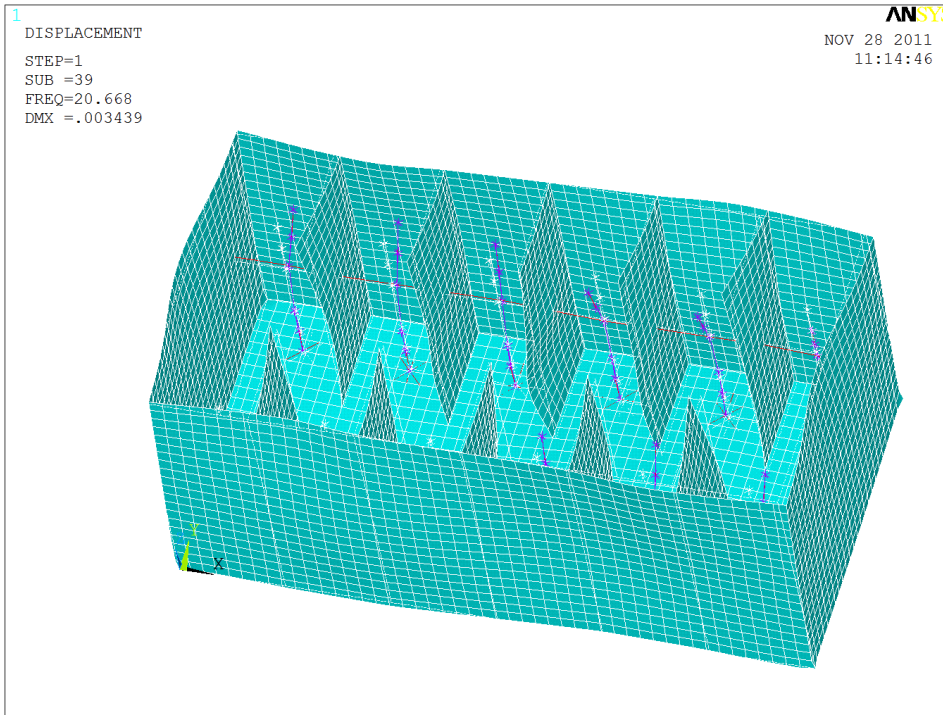

Figure 4-22 Mode Shape 39: Containments (2nd Mode – Combination 1)

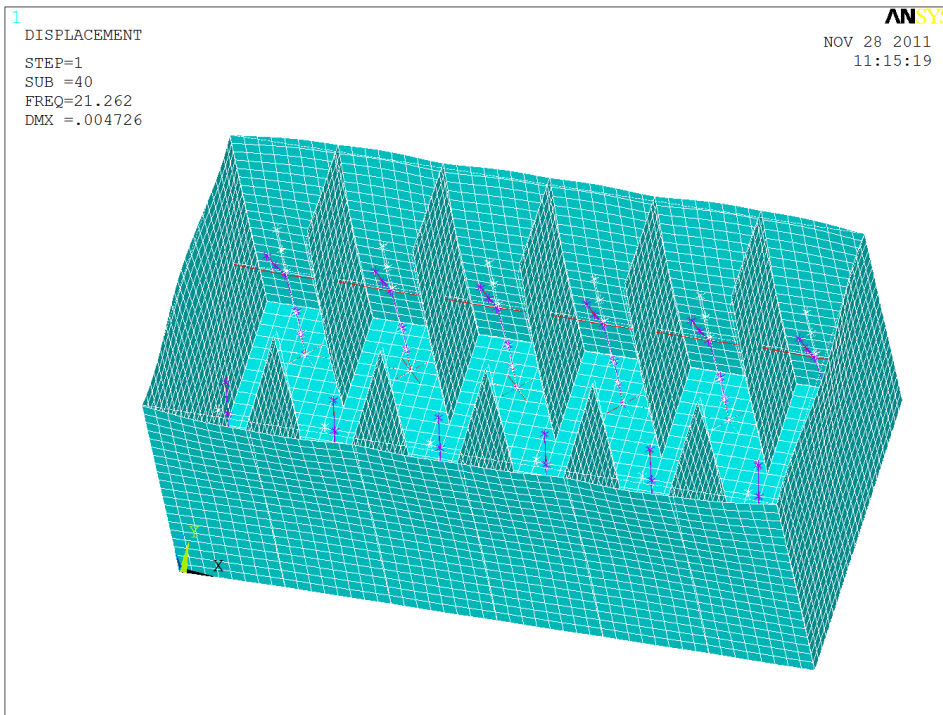

Figure 4-23 Mode Shape 40: Containments (2nd Mode – Combination 2)

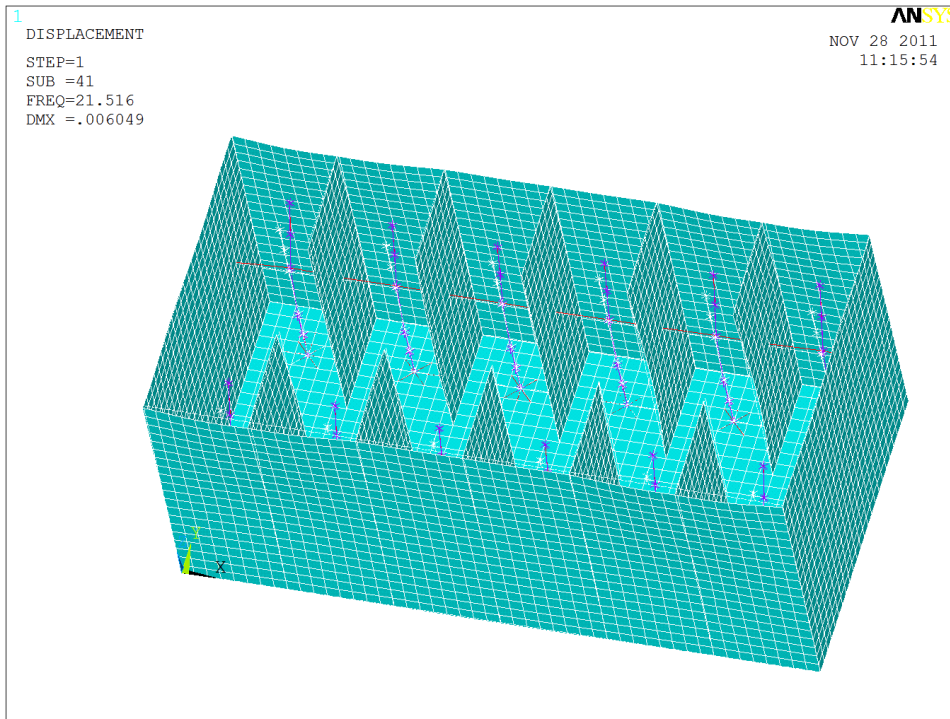

Figure 4-24 Mode Shape 41: Containments (2nd Mode – Combination 3)

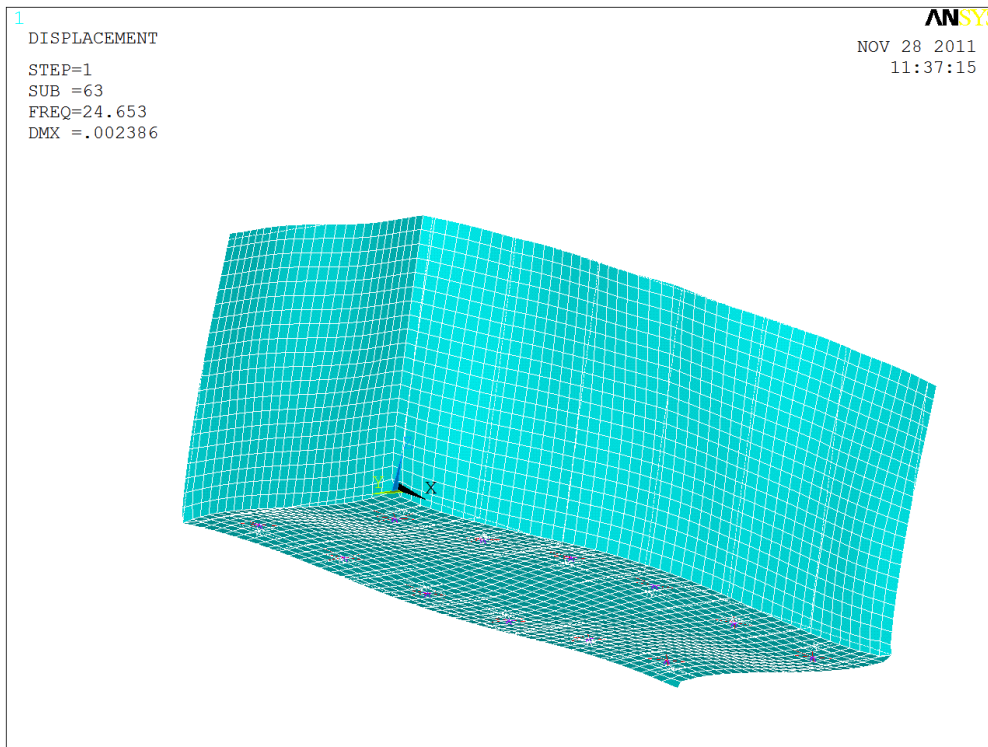

Figure 4-25 Mode Shape 63: Walls and Basemat (Higher Mode – Example 1)

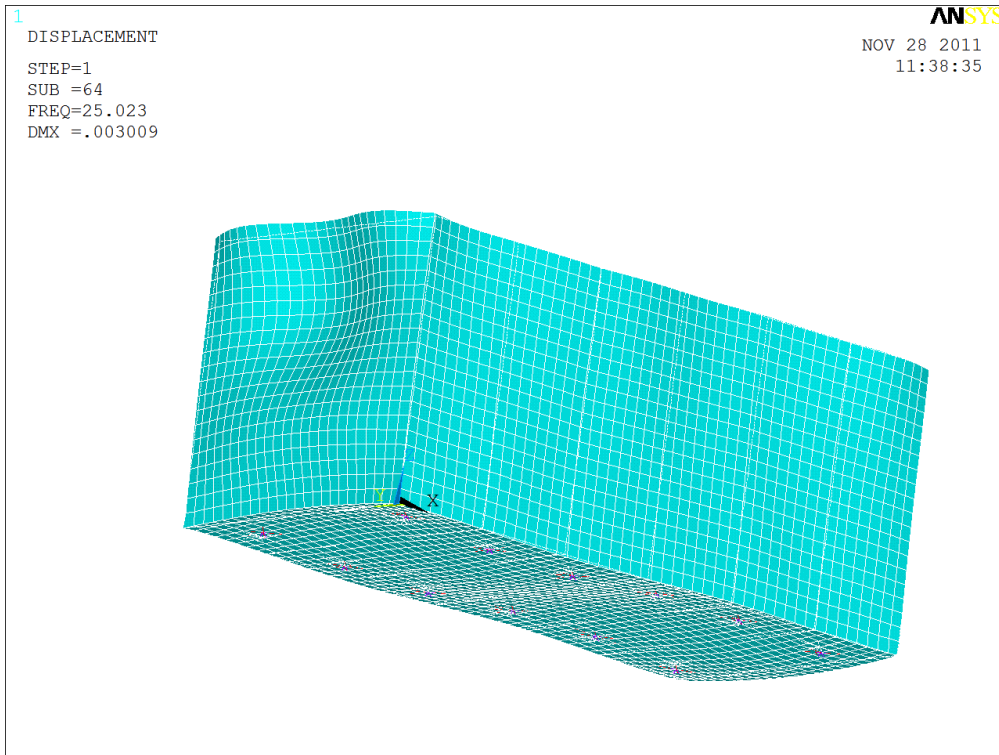

Figure 4-26 Mode Shape 64: Walls and Basemat (Higher Mode – Example 2)

4.3 Transferring ANSYS Model to SASSI House Model

A tool to transform an ANSYS model to the SASSI house model format was developed based on an existing tool that translates a LS-DYNA model to SASSI. The development and verification of this tool is very important in this study because it can facilitate the development of many model permutations that simulate the staged SMR construction/installation process. Since the most difficult task in finite element modeling for SASSI is the development of the house model (including the structural and excavated soil), this tool lends a capability for efficiently generating a SASSI house model by utilizing the ANSYS pre-processor.

This tool has been used to translate the initial ANSYS finite element model as shown in Figure 4-2 to a SASSI house model. The translated model in the SASSI format includes the bulk data, including node definition, SSI node list, solid element definition for the excavated soil, solid/shell/beam/mass element definition for various structural components (perimeter walls, rib walls, basemat, containment, and CIS). The generated file requires additional manual editing to prepare the SASSI control cards and material definitions, which is much easier to do than preparing the bulk data by hand.

The list at the end of this subsection shows an abbreviated version of the SASSI house model (only the bulk data generated from the tool), with many similar lines skipped to show the overall structure of the generated SASSI house input file. This file has comment lines indicating the number of nodes/elements and types of the elements, which are needed information for the preparation of the control cards and material definitions during manual editing.

The SASSI2000 house model allows 4 digits for the node numbers in the node definition although it allows 5 digits for the node numbers in the element connectivity definitions. This indicates that SASSI2000 can only handle 9999 number of nodes, which is only about 1/3 of the total number of nodes. For cases where two symmetry planes can be taken advantage of, the current size of elements can be preserved and the model size will not exceed the node number limit of the SASSI2000 code. However, for cases that can only use one symmetry plane or none, either the size of the elements must be increased or a newer version of SASSI must be used. To increase the size of the elements, a smaller cutoff frequency must be chosen by examining the results of the modal analysis, including the participation factor, effective mass, mode shapes of major components, and the soil column as well. This approach is preferable and should be explored as the first priority if the project is to be reinstated. A newer version of SASSI may have relieved the limitation of node numbering; for example, a 5 digit field for node numbering in the node definition is sufficient to accommodate the size of the current model.

List of Abbreviated SASSI2000 House Model

```

# Nodal points. # of points 27433
  50  0  0  0  0  0  0  0.0000  75.0000  40.0000  0
 114  0  0  0  0  0  0  0.0000  15.0000  40.0000  0

..... SKIPPED 9166 LINES .....

9998  0  0  0  1  1  1  82.5000  10.8367  56.0000  0
9999  0  0  0  1  1  1  82.5000  10.8072  60.0000  0
10000  0  0  0  1  1  1  82.5000  10.7776  64.0000  0
10001  0  0  0  1  1  1  82.5000  10.7481  68.0000  0

..... SKIPPED 18259 LINES .....

28261  0  0  0  1  1  1  3.6992  86.2499  72.0366  0
28262  0  0  0  1  1  1  3.7500  86.2500  76.0000  0
# Interface Node: # of nodes: 4105
  50 114 115 116 127 128 129 130 131 132 133 134 135 136 137 138
 258 259 260 261 262 263 264 265 266 267 268 357 358 359 360 361

..... SKIPPED 252 LINES .....

6602 6603 6604 6605 6606 6607 6608 6609 6610 6611 6612 6613 6614 6615 6616 6617
6618 6619 6620 6621 6622 6623 6624 6625 6626 6627 6628 6629 6630 6631 6632 6633
6634 6635 6636 6637 6638 6639 6640 6641 6642 0
# solid element group [soil]: 1 , # of elements: 23040 , ANSYS element type: 9
 123040  0  0
  1 3270 4245 4269 3271 5564 6236 7724 5633  2 -1  1
  2 4245 4246 4262 4269 6236 6237 8617 7724  2 -1  1

..... SKIPPED 23036 LINES .....

230392736928262 6182 6181 6908 6907 5953 5954  2 -1  1
2304028262 5314 5254 6182 6907 5263 5253 5953  2 -1  1
# shell element group: 1 , # of elements: 4480 , ANSYS element type: 1
  3 4480  1 -1
  1 #material data

```

```

1 259 268 294 287 1 0 4.0000
2 268 267 301 294 1 0 4.0000

..... SKIPPED 4476 LINES .....

4479 6619 6642 5574 5575 1 0 4.0000
4480 6642 6413 5573 5574 1 0 4.0000
# shell element group: 2 , # of elements: 1152 , ANSYS element type: 10
3 1152 1 -1
2 #material data
1 1708 1711 4047 4046 1 0 8.0000
2 1711 1710 4054 4047 1 0 8.0000

..... SKIPPED 1148 LINES .....

1151 1531 1528 4222 4979 1 0 8.0000
1152 4366 1978 1985 4978 1 0 8.0000
# beam element group: 1 , # of elements: 36 , ANSYS element type: 2
2 36 1 1 -1
1 #material data
1 127 150 1 1 1
2 150 151 1 1 1

..... SKIPPED 32 LINES .....

35 249 250 1 1 1
36 250 251 1 1 1
# beam element group: 2 , # of elements: 240 , ANSYS element type: 3
2 240 1 1 -1
2 #material data
1 50 153 1 1 1
2 154 117 1 1 1

..... SKIPPED 236 LINES .....

239 138 4259 1 1 1
240 138 4257 1 1 1
# beam element group: 3 , # of elements: 36 , ANSYS element type: 4
2 36 1 1 -1

```

```

3 #material data
1 155 156 1 1 1
2 156 157 1 1 1

..... SKIPPED 32 LINES .....

35 255 256 1 1 1
36 256 257 1 1 1
# mass group: 1 , # of elements: 24 , ANSYS element type: 5
127 0 1552.8 1552.8 1552.8
155 0 1552.8 1552.8 1552.8

..... SKIPPED 20 LINES .....

138 0 1552.8 1552.8 1552.8
254 0 1552.8 1552.8 1552.8
# mass group: 2 , # of elements: 12 , ANSYS element type: 6
150 0 1397.52 1397.52 1397.52
159 0 1397.52 1397.52 1397.52

..... SKIPPED 8 LINES .....

240 0 1397.52 1397.52 1397.52
249 0 1397.52 1397.52 1397.52
# mass group: 3 , # of elements: 36 , ANSYS element type: 7
151 0 931.677 931.677 931.677
156 0 931.677 931.677 931.677

..... SKIPPED 32 LINES .....

255 0 931.677 931.677 931.677
256 0 931.677 931.677 931.677
# mass group: 4 , # of elements: 24 , ANSYS element type: 8
152 0 1242.24 1242.24 1242.24
158 0 1242.24 1242.24 1242.24

..... SKIPPED 20 LINES .....

251 0 1242.24 1242.24 1242.24

```

257	0	1242.24	1242.24	1242.24
-----	---	---------	---------	---------

5 FUTURE EFFORT

In light of the possibility of near future licensing applications of the small modular reactor designs, this project is believed to have a great value for assessing the adequacy and applicability of the current SRP and RGs for multiple modular reactors on a common foundation and providing recommendations on updates of these documents. Therefore, this status report has been prepared in a way that if the staff decides to reinstate the project in the future, the project can be restarted in an efficient manner which would permit a smooth continuation of the entire planned effort. To complete the understanding of the entire research effort, this section provides a summary of the remaining tasks to achieve the original goal of the project. General remarks on the water-structure interaction for submerged containments are presented, and an extended list of important files and their locations is included at the end of this section as well.

5.1 Remaining Tasks

The previous sections cover the original research plan, input spectra development, seed record selection, synthetic input motion generation, the ANSYS model development, determination of structural dynamic characteristics, and a tool for the development of SASSI House models.

Based on a review of the SMR designs, significant seismic issues that demand detailed investigations have been identified. These issues include module-soil/water-module interaction, soil-foundation-module interaction, deeply embedded or completely buried foundations, the use of base-isolation devices, staged construction sequence, as well as the adequacy of the computational tools. More issues are expected to be revealed during the analytical effort and when applying the results to the development of recommendations for updating the relevant SRP sections and regulatory guidance.

In light of recent reports on potentially unrealistic results produced by SASSI in certain situations and the concerns on the quality assurance of different versions of SASSI, it is important that its applicability and limitations for analysis of SMRs be well understood, especially for completely embedded structures. Therefore, some benchmarking of the SASSI code should be performed by a combination of comparison to LS-DYNA, test data, and/or published known solutions.

As for the analytical effort, the cutoff frequency to determine the element size will need to be adjusted based on the results of the modal analysis, the input spectra, and the soil columns. An initial selection of 50 Hz was purely based on the frequency content of the input spectra. The ANSYS modal analysis suggested that a cutoff frequency between 17.5 Hz and 25 Hz would be appropriate when only the structural responses were considered. The goal of choosing a smaller cutoff frequency is to increase the element size and consequently reduce the model size. A newer/revised version of SASSI may be needed in the future if the SASSI house model is still too large after enlarging the element size. The large model is mainly due to the large excavated soil model, which is normally small for typical light water reactor designs that have relatively small embedment.

The translated SASSI model will need to be manually edited to enter the various control cards and material definitions. All other bulk data defining the nodes and elements have already been generated by transferring the ANSYS model to the SASSI format. There will be a verification analysis of the SASSI model (modal analysis) for the base layout to compare the natural frequencies to those generated in the ANSYS modal analysis. This process will possibly result in some adjustment to the models. The

limitations of the SASSI code, as the benchmarks described above would confirm or disconfirm, will be fully considered in this verification analysis.

After the benchmark and verification of the models, the major analytical effort will be to assess the seismic responses of SMRs on a common foundation for the parametric permutations as described in Section 2. Based on the results of these analyses, LS-DYNA models may be developed to better represent the structure-water-structure integration and assess the nonlinear SSI effects (sliding, uplifting, and separation between the soil-structure interface) if these nonlinear effects are judged to be significant during the SASSI linear analyses.

The results of the analytical effort will be used to evaluate their impact on current seismic criteria, and provide recommendations for updating regulatory guidance (SRP, RGs). The limitation of the current seismic calculation methodologies and software tools will also be identified and recommendations will be provided regarding the needed theoretical and computational development for proper seismic analysis and design of the SMRs.

A NUREG/CR is planned to document the research findings and the recommendations for improvements to the regulatory documents and computational tools.

5.2 Remarks on Water-Structure Interaction

Historically and currently in the nuclear industry, the water-structure interaction effect has been treated using the hydrodynamic mass approach. Fritz's work in 1972, "The Effect of Liquids on the Dynamic Motions of Immersed Solid," [Ref. 5] has been popularly referenced for the seismic analysis of spent fuel racks submerged in the spent fuel pools. This approach combines the fluid dynamic effect with the structural masses utilizing additional (fluid) diagonal and off-diagonal mass terms; consequently, the resultant fluid forces on the vibrating structural components are only the result of the acceleration time history of vibrating bodies in the fluid. According to Patton [Ref. 6], "when the forces acting on a body moving at constant velocity in a constant-density, ideal fluid are integrated over the surface of the body, the resultant force is found to be zero. This is commonly referred to as D'Alembert's paradox; i.e., the body has no resistance to motion." In the case of the body moving with unsteady motion, the resultant force is found to be identical with the force induced by a mass of fluid added to that of the body, i.e., the *added mass* or *hydrodynamic mass*. For more information on the D'Alembert's paradox, a theoretic explanation can be found in Ref. 7.

The verification of the analytical methods has been based on relatively limited test data [for example, in Refs 5 & 6]. As indicated by Patton [Ref. 6], the hydrodynamic mass is a function of frequency and the displacement magnitude. It was recognized in the same reference that the force due to hydrodynamic mass is not the only force, for example, viscous force. For high frequency vibrations, it is believed that the impact force between the oscillating body and the surrounding fluid may become significant.

Fritz's method assumes infinitesimal displacement relative to the gap between two bodies, while in reality the relative seismic displacement can be very large. The development of Fritz's method assumes rigid structural components, which may not be appropriate for large shell structures such as submerged steel containments. This method has other restrictions that have sometimes been neglected, such as fluid velocity to be less than 10% of the speed of sound in the fluid, and the flow channel length to be less than 10% of the wave length.

NUREG/CR-5912 [Ref. 8], "Review of the Technical Basis and Verification of Current Analysis Methods Used to Predict Seismic Response of Spent Fuel Storage Racks," identified some specific technical issues in the hydrodynamic mass approach and other issues that should be studied further. However, since that time, there has not been much research effort to address these issues.

This project, when reinstated in the future, should be a good opportunity to study the water-structure interaction effects and to address the specific issues identified above. It is recommended that the hydrodynamic mass approach should be verified more rigorously, for example, against test results and other simulation approaches (different fluid elements, computer codes, more complex models, and various levels of seismic excitations). The results from this project may also be applicable to the seismic analysis of submerged structures and components such as spent fuel racks submerged in the spent fuel pool.

5.3 List of Important Files

Important files developed in this study are listed below to facilitate a convenient access to these files when the project would be reinstated in the future. The following list includes only major files that are necessary for a good understanding of the project and an efficient revisit of the modeling effort.

5.3.1 On BNL's Workstation No. 146357

The root directory for the project is "C:\Users\jnie\Documents\SMR JCN V-6096 15455". Important files or subdirectories are listed below:

\Reports

15 files generated during the close out process.

<i>Special-Seismic-Issues-for-SMR-2011-02-28.docx</i>	First draft before task 1 letter report
<i>SMR Task1 Letter Report 2011-04-30.docx</i>	Task 1 letter report
<i>SMR Progress Report 2011-09-01.docx</i>	progress report
<i>BNL V-6096 close out plan 10-5-11.docx</i>	closeout plan
<i>Status-Report-for-SMR-on-a-Common-Foundation-2011-12-21.docx</i>	this report

\Input Ground Motions\SMR Input Spectra

Many files for the development of input spectra.

<i>SMR Spectra.xlsx</i> :	Generic (enveloping) input spectra
<i>CSDRS_USAPWR.py</i> :	Python functions to define the US APWR spectra
<i>env_spectra.py</i> :	Python functions to define the generic input spectra
<i>Envelope-CSDRS-Hor-final.txt</i> :	Data file to define the horizontal spectra (used by <i>env_spectra.py</i>)
<i>Envelope-CSDRS-Ver-final.txt</i> :	Data file to define the vertical spectrum (used by <i>env_spectra.py</i>)
<i>Envelope-CSDRS-Hor-final-period.txt</i> :	Data file to define the horizontal spectra for use with PEER Ground Motion Database (online)
<i>Envelope-CSDRS-Ver-final-period.txt</i> :	Data file to define the vertical spectrum for use with PEER Ground Motion Database (online)
<i>SMR Input Motion Development 2011-08-08.docx</i> :	Information collected during review of the four standard designs.

\Input Ground Motions\PGMD

Many files and two subdirectories for obtaining seed records using the online PEER Ground Motion Database.

<i>pgmd-explorer.py</i> :	Python script to determine the best seeds and generate figures such as Figure 3-3 through Figure 3-8
<i>Hor-Scaled-AccelRecords_rotated.zip</i> :	Downloaded PGMD records for the horizontal direction
<i>Ver-unscaled-AccelRecords_rotated.zip</i> :	Downloaded PGMD records for the vertical direction

\Input Ground Motions\PGMD\Hor_scaled_rotated

Seed records for the horizontal direction and processing scripts.

<i>print_summary.py</i> :	Python script to print a summary of the downloaded records
<i>check_corrcoef.py</i> :	Python script to check the correlation coefficients of three records
<i>Hor_sum_acc.txt</i> :	summary of all downloaded seed records for the horizontal directions
<i>Hor_sum_at2.txt</i> :	summary of all downloaded seed records for the vertical directions

\Input Ground Motions\PGMD\Ver_scaled_rotated
Similar to *\Hor_scaled_rotated*

\Input Ground Motions\PGMD\synthetic time histories
40 files for development of the synthetic time histories.

check_corrcoef.py: Python script to check correlation coefficients of three records

check_corrcoef_chopped_seeds.py: check correlation coefficients of chopped seed records

check_corrcoef_original_seeds.py: check correlation coefficients of original seed records

chopwaves.py: chop seed records to about 20 seconds

env_spectra.py: functions to define the generic input response spectra

syn.py: Python script to start the synthesis process

chopped-NGA180FN.txt: seed record (chopped)

SMR_H1-ACC.txt: generated acceleration records for horizontal direction 1 (similarly for other two directions)

SMR_H1-VEL.txt: velocity history

SMR_H1-DISP.txt: displacement history

SMR_H1-FC.txt: Fourier amplitude spectrum

SMR_H1-PSD.txt: power spectrum density

SMR_H1-RS.txt: response spectrum

\Input Ground Motions\References

References to develop the algorithm for generation of synthetic acceleration time histories.

\Closeout

45 files generated during the close out process.

ANSYS modal analysis.xlsx: effective mass distribution over frequency

sassi.inp: generated SASSI House model

args.txt: arguments to script *ansys2sassi.py* (which is located in *python27-site/scripts*)

smr.cdb: ANSYS CDB file

SMR-10-28-11.zip: ANSYS model and mode shape images prepared by Xing

\DOE-NRC CEUS Seismic Source Characterization

Some references on DOE-NRC CEUS seismic source characterization study.

\SASSI Models

Two Mathcad files from previous studies to develop SASSI soil profiles.

\Sketchup Models

Files to develop the sketch shown in Figure 2-1 using Google Sketchup.

\Refs about SASSI

References for the SASSI computer codes.

\HTGR Refs

References for high temperature gas reactors.

\iPWR Refs

References for integrated PWR reactors.

\LMR Refs

References for liquid metal reactors.

\Earthquake Review References

References for recent earthquakes affecting nuclear power plants.

\OECD - Earthquake Surveys

Additional references for recent earthquakes affecting nuclear power plants.

5.3.2 On BNL “BLC Cluster Head Node Spot”

\lsdyna

Various versions of the LS-DYNA (MPP, SMP, etc) code.

\lsc_server

LSTC license server files for LS-DYNA

\smr

Subdirectories for the benchmark study of the performance of various LS-DYNA versions and CPU configurations. All benchmark models were taken from previous studies. Files with extension .pbs are the job submission scripts for the cluster.

5.3.3 On BNL's Workstation No. 147395

All files needed for resuming the ANSYS model are located in the following directory in this computer:

C:\xwei\NRC\NRO\SMR\ansys model\11-28-2011

contmnt4.mac: add containment before element meshing

mmerge2.mac: merge nodes

modal2.mac: perform modal analysis

draft 2-2.db: ANSYS database file with excavated soil model

6 REFERENCES

- 1) Letter Report: *Special Seismic Issues for Small Modular Reactors*, First Draft, February 25, 2011. Prepared by Brookhaven National Laboratory.
- 2) Task 1 Letter Report: *Seismic Performance of Multiple Modular Reactors on a Common Foundation*, April 29, 2011. Prepared by Brookhaven National Laboratory.
- 3) Progress Report: *Seismic Performance of Multiple Modular Reactors on a Common Foundation*, Draft, September 1, 2011. Prepared by Brookhaven National Laboratory.
- 4) *Issues Related to the SASSI Computer Software*, Prepared by Defense Nuclear Facilities Safety Board, March 3rd, 2011. URL: <http://www.dnfsb.gov/board-activities/reports/staff-issue-reports/issues-related-sassi-computer-software>.
- 5) Fritz, R.J. (1972). "The effect of liquids on the dynamic motions of immersed solids," *Journal of Engineering for Industry*, **167**, February, 1972.
- 6) Patton K.T. (1965). *Tables of Hydrodynamic Mass Factors for Translation Motion*, presentation at the ASME Winter Annual Meeting, Chicago, Il., November 7-11, 1965.
- 7) D'Alembert's paradox, URL: http://en.wikipedia.org/wiki/D%27Alembert%27s_paradox
- 8) DeGrassi, G. (1992). *Review of the Technical Basis and Verification of Current Analysis Methods Used to Predict Seismic Response of Spent Fuel Storage Racks*, NUREG/CR-5912, prepared by Brookhaven National Laboratory for the U.S. Nuclear Regulatory Commission, Washington DC.