

**Turkey Point Nuclear Plant 2011
Senior Reactor Operator License Examination**

1.

Initial Conditions:

- A Loss of Offsite Power has occurred on both Unit 3 and 4 due an electrical grid imbalance.

Current Conditions:

- The crew is performing actions of 3-EOP-ES-0.1, Reactor Trip Response.
- Offsite Power has NOT been restored.
- RCS Thot is 565°F and slowly lowering.
- RCS Tcold is 540°F and slowly lowering.
- S/G Steam Dumps to Atmosphere are modulated open.
- Total AFW flow is 450 gpm and stable.
- All S/G levels indicate 1% NR and rising slowly.

Which ONE of the following describes the MINIMUM required actions In accordance with 3-EOP-ES-0.1?

- A. Continue dumping steam. Continue at 450 gpm AFW flow until one S/G is greater than 6% narrow range and then lower AFW flow to just above 345 gpm.
- B. Stop dumping steam. Reduce AFW flow to just above 345 gpm until at least one S/G is greater than 32% narrow range.
- C. Continue dumping steam. Continue at 450 gpm AFW flow until one S/G is greater than 50% narrow range and then control flow as necessary to maintain 50-60% level.
- D. Stop dumping steam. Continue at 450 gpm AFW flow. If cooldown continues, then reduce AFW flow to just above 345 gpm until at least one S/G is greater than 6% narrow range.

**Turkey Point Nuclear Plant 2011
Senior Reactor Operator License Examination**

2.

Given the following:

- Unit 3 was manually tripped and safety injection was manually actuated due to a Pressurizer Safety Valve leaking.
- The crew is performing actions of 3-EOP-E-0, Reactor Trip or Safety Injection.

Subsequently,

- All Unit 3 RCPs are manually tripped.
- Tcold is 548°F and slowly RISING.
- Pressurizer Pressure is 1700 psig and slowly LOWERING.
- PZR Level is 33% and slowly RISING.
- PRT Pressure is 30 psig.
- S/G Pressures are at 1015 psig.
- PI-3-1406, Condenser Vacuum, indicates 18" Hg and stable.

Which ONE of the following completes the statements below?

The downstream tailpipe temperature is ____ (1) ____.

The Steam Dump To Atmosphere Valves are operated by ____ (2) ____ to meet the RCS temperature requirements in accordance with 3-EOP-E-0.

REFERENCE PROVIDED

- A. (1) 275°F
(2) Manually adjust the S/G Steam Dump To Atmosphere Controller Setpoint in Automatic by pushing the "SV Decrease Key "(arrow points down).
- B. (1) 275°F
(2) Manually adjust the S/G Steam Dump To Atmosphere Controller Setpoint in Automatic by pushing the "MV Increase Key "(arrow points to the right).
- C. (1) 400°F
(2) Manually adjust the S/G Steam Dump To Atmosphere Controller Setpoint in Automatic by pushing the "SV Decrease Key "(arrow points down).
- D. (1) 400°F
(2) Manually adjust the S/G Steam Dump To Atmosphere Controller Setpoint in Automatic by pushing the "MV Increase Key "(arrow points to the right).

**Turkey Point Nuclear Plant 2011
Senior Reactor Operator License Examination**

3.

Given the following conditions:

- The crew is performing the actions in 3-EOP-ES-1.2, Post LOCA Cooldown and Depressurization.
- SI pumps have been stopped.
- Normal charging is aligned.
- The crew is cooling down and depressurizing the RCS using normal spray.

Which ONE of the following identifies the reason why subcooling is controlled during RCS depressurization while in 3-EOP-ES-1.2?

- A. To ensure continued RCP operation.
- B. To reduce RCS break flow.
- C. To prevent a challenge to the Core Cooling CSF.
- D. To prevent a challenge to the Integrity CSF.

**Turkey Point Nuclear Plant 2011
Senior Reactor Operator License Examination**

4.

The following plant conditions exist when exiting 3-EOP-E-0, Reactor Trip or Safety Injection:

- Containment Pressure is 29 psig and lowering.
- RCPs have been stopped.
- Core Exit Thermocouples are 710°F and rising.
- PZR Level is off scale low.
- RCS Pressure is 400 psig and lowering.
- RCS Wide Range Hot Leg Temperatures are 680°F and rising.

Which ONE of the following identifies (1) the initiating event and (2) the NEXT required procedure?

- A. (1) A Faulted S/G Inside Containment
(2) Transition to 3-EOP-FR-Z.1, Response to High Containment Pressure
- B. (1) A Faulted S/G Inside Containment
(2) Transition to 3-EOP-FR-C.2, Response to Degraded Core Cooling
- C. (1) A RCS Cold Leg Break
(2) Transition to 3-EOP-FR-Z.1, Response to High Containment Pressure
- D. (1) A RCS Cold Leg Break
(2) Transition to 3-EOP-FR-C.2, Response to Degraded Core Cooling

**Turkey Point Nuclear Plant 2011
Senior Reactor Operator License Examination**

5.

Given the following:

- Unit 3 was operating at 100% power when a Loss of Offsite Power occurred on both units.
- The operating crew has implemented 3-EOP-ES-0.1, Reactor Trip Response.
- RCS Pressure is 2210 psig and stable.
- Pressurizer Level is 35% and lowering.
- Tavg is 552 °F and lowering.
- Containment Temperature is 170°F.
- Offsite Power is expected to be restored within 24 hours.

Which ONE of the following identifies the required S/G level control band setpoints and the reason for the band in accordance with 3-EOP-ES-0.1, Reactor Trip Response, Basis Document?

- A. (1) BETWEEN 15% and 50%
(2) to preclude AFW auto re-initiation AND establish a heat sink which will enhance natural circulation
- B. (1) BETWEEN 32% and 50%
(2) to preclude AFW auto re-initiation AND establish a heat sink which will enhance natural circulation
- C. (1) BETWEEN 15% and 50%
(2) to enhance natural circulation AND ensure a Steam Generator Tube Leak is NOT in progress
- D. (1) BETWEEN 32% and 50%
(2) to enhance natural circulation AND ensure a Steam Generator Tube Leak is NOT in progress

**Turkey Point Nuclear Plant 2011
Senior Reactor Operator License Examination**

6.

The crew has transitioned from 3-EOP-ECA-0.0, Loss of All AC Power, to 3-EOP-ECA-0.1, Loss of All AC Power Recovery Without SI Required.

The following plant conditions exist:

- Annunciator A 1/2, RCP THERMAL BARR COOLING WATER HI TEMP, is lit.
- Annunciator A 1/6, RCP #1 SEAL LEAK OFF HI TEMP, is lit.
- Common Seal Water Return Temperature to CVCS is 250°F.
- No. 1 Seal Water Outlet Temperature for all RCPs is 250°F.
- RCP Thermal Barrier CCW Outlet Valve, MOV-3-626, is closed.
- RCP Seal Injection Throttle Valves, 3-297A, 3-297B, and 3-297C were initially isolated.

Which ONE of the following describes (1) the required actions and (2) the reason for this action?

- A. (1) RCP Seal Injection Throttle Valves, 3-297A, 3-297B, and 3-297C, must be left closed.
(2) To prevent thermal shock to the RCP Seals
- B. (1) RCP Seal Injection Throttle Valves, 3-297A, 3-297B, and 3-297C, must be left closed.
(2) To prevent water hammer in the RCP Thermal Barrier Heat Exchanger
- C. (1) RCP Seal Injection Throttle Valves, 3-297A, 3-297B, and 3-297C are required to be locally throttled open to establish flow of 2 gpm.
(2) To prevent thermal shock to the RCP Seals
- D. (1) RCP Seal Injection Throttle Valves, 3-297A, 3-297B, and 3-297C, are required to be locally throttled open to establish flow of 2 gpm.
(2) To prevent water hammer in the RCP Thermal Barrier Heat Exchanger

**Turkey Point Nuclear Plant 2011
Senior Reactor Operator License Examination**

7.

Given the following initial conditions:

- Unit 3 is cooling down using 'A' RHR Train.
- RCS temperature is 310°F.
- RCS pressure is 340 psig.
- PZR level is 22%.

Subsequently:

- PZR level is at 10% and slowly lowering.
- Charging is at maximum flow.
- Letdown is isolated.
- Containment radiation levels are rising.
- The running RHR pump trips.

Which ONE of the following actions is performed FIRST in accordance with 3-ONOP-041.7, Shutdown LOCA [Mode 3 (Less than 1000 PSIG) or Mode 4]?

- A. Actuate Safety Injection
- B. Manually align High Head Safety Injection Pumps to RCS Cold Legs
- C. Restore power and open Unit 3 SI Accumulator Outlet Valves
- D. Manually align the non-operating train of RHR for Injection

**Turkey Point Nuclear Plant 2011
Senior Reactor Operator License Examination**

8.

Given the following conditions:

- Unit 3 Reactor power is 100%.
- Pressurizer Pressure Control is in automatic.
- An operator inadvertently sets PC-3-444J, Pressurizer Pressure Controller potentiometer, fully clockwise (10.0).

Which ONE of the following describes the IMMEDIATE response of the Pressurizer Pressure Control System?

- A. Pressurizer PORV, PCV-3-455C will open.
- B. Both Pressurizer Spray Valves will open.
- C. Backup Group A and B Pressurizer Heaters energize.
- D. Control Group Pressurizer Heaters reduce to minimum current.

**Turkey Point Nuclear Plant 2011
Senior Reactor Operator License Examination**

9.

Given the following conditions:

- Unit 3 is at 90% power.
- RPS Testing is in progress.
- Reactor Trip Breaker A (RTA) is CLOSED.
- Reactor Trip Breaker B (RTB) is OPEN.
- Reactor Trip Bypass Breaker B (BYB) is Racked In and CLOSED.

During the testing the following occurs:

- The "A" RCP shaft seizes.
- A Reactor Trip signal is NOT generated by Protection Train B.
- Protection Train A generates a Reactor Trip signal as designed.
- The Reactor does NOT automatically trip.
- Manual Reactor Trip was successful.

Which ONE of the following identifies ALL the Reactor Trip Breaker Trip Coils and Reactor Trip Bypass Breaker Trip Coils that have changed state to trip the Reactor?

- A. The RTA Undervoltage Trip Coil and the BYB Shunt Trip Coil only.
- B. The RTA Shunt Trip Coil and the BYB Shunt Trip Coil only.
- C. The RTA Undervoltage Trip Coil, the RTA Shunt Trip Coil, and the BYB Undervoltage Trip Coil only.
- D. The RTA Undervoltage Trip Coil, the RTA Shunt Trip Coil, the BYB Undervoltage Trip Coil, and the BYB Shunt Trip Coil only.

**Turkey Point Nuclear Plant 2011
Senior Reactor Operator License Examination**

10.

Given the following:

- A Steam Generator Tube Rupture has occurred on 3C S/G.
- RCS cooldown and depressurization is complete.
- Preparations are made to transition to 3-EOP-ES-3.1, Post SGTR Cooldown using Backfill.
- Pressurizer Level is 38%.
- 3B RCP is running.
- RCS Subcooling is 40°F.
- Letdown is isolated and unavailable.
- 3C S/G Narrow Range Level is 73% and slowly rising.

Which ONE of the following identifies the MINIMUM required action and the reason in accordance with 3-EOP-E-3, Steam Generator Tube Rupture?

- A. Open one Pressurizer PORV to raise PZR Level
- B. Open one Pressurizer PORV to minimize RCS leakage
- C. Open PCV-3-455B Pressurizer Spray Valve to minimize RCS leakage
- D. Open PCV-3-455A Pressurizer Spray Valve to raise PZR Level

**Turkey Point Nuclear Plant 2011
Senior Reactor Operator License Examination**

11.

Given the following conditions:

- A steamline break has occurred on Unit 3 Turbine Deck.
- The Main Steamline Isolation Valves are OPEN and cannot be closed using the control switches on Console 3C02 or pushbuttons on VPB.

Which ONE of the following identifies the NEXT required action and where it is accomplished in accordance with 3-EOP-ECA-2.1, Uncontrolled Depressurization of All Steam Generators?

- A. Pull fuses behind Console 3C02 for **ONLY ONE** train of solenoids for the MSIVs
- B. Pull fuses behind Console 3C02 for **BOTH** trains of solenoids for the MSIVs
- C. Pull fuses at the Alternate Shutdown Panel for **ONLY ONE** train of solenoids for the MSIVs
- D. Pull fuses at the Alternate Shutdown Panel for **BOTH** trains of solenoids for the MSIVs

**Turkey Point Nuclear Plant 2011
Senior Reactor Operator License Examination**

12.

Given the following:

- Unit 4 is at 70% power.
- Steam Generator Main Feed Pumps 4A and 4B are in service.

Subsequently,

- 4A Steam Generator Main Feed Pump trips.
- Alarm SGFP A/B MOTOR OVERLOAD TRIP (D 6/1) is received.
- Turbine Load remains stable.

Which ONE of the following describes the required action and the reason for this action?

- A. Manually open the Main Feedwater Regulating Valves to stabilize S/G levels
- B. Start the standby Condensate Pump to maintain Main Feed Pump suction pressure
- C. Manually reduce turbine load to prevent exceeding rod insertion limits
- D. Manually reduce turbine load to reduce steam demand to stabilize S/G levels

**Turkey Point Nuclear Plant 2011
Senior Reactor Operator License Examination**

13.

Given the following:

- A station blackout occurred on Unit 3.
- The operating crew is performing 3-EOP-ECA-0.0, Loss of All AC Power.
- NEITHER Unit 3 EDG can be started.
- The 4KV Bus 3B Lockout Blue lights are flashing.
- BOTH Unit 4 EDGs are operating and supplying their respective 4 KV Busses.
- Off-Site power availability is NOT expected within the next 2 hours.

Which ONE of the following describes the actions that are necessary to restore power?

Align 4KV Bus ____ (1) ____ using the Station Blackout Tie Line in accordance with ____ (2) ____.

- A. (1) 3A
(2) 3-ONOP-004.1, System Restoration Following Loss of Offsite Power
- B. (1) 3B
(2) 3-ONOP-004.3, Loss of 3B 4KV Bus
- C. (1) 3B
(2) 3-ONOP-004.1, System Restoration Following Loss of Offsite Power.
- D. (1) 3A
(2) 3-ONOP-004.2, Loss of 3A 4KV Bus

**Turkey Point Nuclear Plant 2011
Senior Reactor Operator License Examination**

14.

Given the following:

- The station experiences a Loss of Offsite Power.
- One of the undervoltage relays for the 4B 4KV Bus fails to actuate.
- All 480V Load Center undervoltage and degraded voltage relays operate properly.

For Unit 4, which ONE of the following describes (1) the bus-stripping response and (2) the response of the EDG(s) Output Breakers?

- A. (1) Bus stripping will occur ONLY on Bus 4A;
(2) ONLY the 'A' EDG output breaker will close.
- B. (1) Bus stripping will occur on Bus 4A AND on Bus 4B;
(2) ONLY the 'A' EDG output breaker will close.
- C. (1) Bus stripping will occur ONLY on Bus 4A;
(2) BOTH the 'A' EDG AND the 'B' EDG output breakers will close.
- D. (1) Bus stripping will occur on Bus 4A AND on Bus 4B;
(2) BOTH the 'A' EDG AND the 'B' EDG output breakers will close.

**Turkey Point Nuclear Plant 2011
Senior Reactor Operator License Examination**

15.

Unit 3 is operating at 100% power when VITAL AC BUS INVERTER TROUBLE (F 1/2) alarms.

Subsequently, the following annunciators are received (NOT all inclusive):

- POWER RANGE LOSS OF DETECTOR VOLTAGE (B 6/5)
- INTERM RANGE N-35 LOSS OF COMP VOLTAGE (B 5/3)
- SEQUENCER 3B TROUBLE (X1/4)

Which one of the following identifies the vital panel that has lost power and the expected consequence?

- A. 3P08 lost power; control 3A S/G level in manual
- B. 3P08 lost power; control 3C S/G level in manual
- C. 3P06 lost power; control 3A S/G level in manual
- D. 3P06 lost power; control 3C S/G level in manual

**Turkey Point Nuclear Plant 2011
Senior Reactor Operator License Examination**

16.

Given the following:

- At Unit 3, a loss of Component Cooling Water (CCW) occurs and the operating crew implements 3-ONOP-030, Component Cooling Water Malfunction.
- Emergency cooling water is being aligned to the operating 3A Charging Pump's Oil Cooler per Attachment 1, Control of Emergency Cooling Water to Charging Pumps, of 3-ONOP-030.
- Subsequently, a Loss of Offsite Power occurs and the Diesel Driven Service Water pump cannot be started.

Which ONE of the choices below completes both statements regarding 3A Charging Pump operation in accordance with 3-ONOP-030 Attachment 1?

The 3A Charging Pump is required to be operated at (1) speed until Attachment 1 is complete.

If hydraulic coupling oil temperature (indicated temperature at the oil cooler outlet) reaches 195°F, the required action is to (2) .

- A. (1) REDUCED (but above minimum)
(2) stop 3A Charging Pump
- B. (1) REDUCED (but above minimum)
(2) reduce 3A Charging Pump speed to MINIMUM speed
- C. (1) MAXIMUM
(2) stop 3A Charging Pump
- D. (1) MAXIMUM
(2) reduce 3A Charging Pump speed to MINIMUM speed

**Turkey Point Nuclear Plant 2011
Senior Reactor Operator License Examination**

17.

Given the following:

- Unit 3 is in MODE 4, cooling down to MODE 5.
- 3B RCP is running.
- ONE train of Unit 3 RHR is operating in the cooldown mode.
- Unit 4 is operating at 100% power.
- Instrument Air Pressure for both units cannot be maintained greater than 65 psig.

Which ONE of the following completes both statements in accordance with ONOP-013, Loss of Instrument Air?

In order to safely continue the Unit 3 cooldown the operators are required to ____ (1) ____.

The Unit 4 Reactor is required to be tripped because of the challenge to ____ (2) ____.

UNIT 3

UNIT 4

- | | | |
|----|--|------------------------------|
| A. | Start / Stop RHR Pumps on VPB | Reactivity Control |
| B. | Start / Stop RHR Pumps on VPB | Reactor Coolant Heat Removal |
| C. | Throttle from VPB MOV-3-749A/B,
RHR Hx 3A/B CCW Outlet Valves | Reactivity Control |
| D. | Throttle from VPB MOV-3-749A/B,
RHR Hx 3A/B CCW Outlet Valves | Reactor Coolant Heat Removal |

**Turkey Point Nuclear Plant 2011
Senior Reactor Operator License Examination**

18.

Unit 3 has experienced a unit trip with a failure of Auxiliary Feedwater to supply feed flow to S/Gs. The crew has entered 3-EOP-FR-H.1, Response to Loss of Secondary Heat Sink.

Other plant conditions are as follows:

- All RCPs have been tripped
- Safety Injection Signal has been reset

Containment Conditions

- Atmospheric Air Temperature: 155°F
- Pressure: 0.5 psig
- CHRRMS Radiation Levels: 1R/hr

S/G Wide Range (WR) Levels

- 3A S/G: 24%
- 3B S/G: 34%
- 3C S/G: 25%

In accordance with 3-EOP-FR-H.1, which ONE of the following identifies whether (1) the Feedwater Bypass Isolation Reset Pushbuttons are required to be depressed to restore Feedwater to the S/Gs and (2) if any, feedwater flow restrictions apply?

- A. (1) NOT required to be depressed
(2) Main Feedwater flow may be adjusted with no restrictions
- B. (1) Required to be depressed
(2) Main Feedwater flow may be adjusted with no restrictions
- C. (1) NOT required to be depressed
(2) Main Feedwater flow is limited to 25 gpm
- D. (1) Required to be depressed
(2) Main Feedwater flow is limited to 25 gpm

**Turkey Point Nuclear Plant 2011
Senior Reactor Operator License Examination**

19.

Given the following:

- Unit 4 is operating at 80% power with all parameters at program values.
- All control systems are aligned in automatic.
- Control Bank "D" control rods are at 215 steps.
- ONE Control Bank "C" control rod is dropped, indicating 0 steps.

Which ONE of the following describes (1) the INITIAL Rod Control Power Mismatch Circuit response to the dropped rod and (2) whether power is required to be reduced?

- A. (1) A Rod Control Insertion Demand Signal is generated.
(2) Perform a power reduction.
- B. (1) A Rod Control Insertion Demand Signal is generated.
(2) A power reduction is NOT required.
- C. (1) A Rod Control Withdrawal Demand Signal is generated.
(2) Perform a power reduction.
- D. (1) A Rod Control Withdrawal Demand Signal is generated.
(2) A power reduction is NOT required.

**Turkey Point Nuclear Plant 2011
Senior Reactor Operator License Examination**

20.

Given the following:

- Unit 3 is at 88% power
- During a load reduction, it was determined that 2 rods are mechanically bound.
- One Control Rod in Bank D Group 1 is stuck at 196 steps.
- One Control Rod in Bank D Group 2 is stuck at 196 steps.
- All other Control Bank D Rods are at 192 steps.

In accordance with Technical Specification 3.1.3.1, Movable Control Assemblies - Group Height, which ONE of the following identifies the MINIMUM required action within ONE hour?

- A. Perform 0-OSP-028.8, Shutdown Margin Calculation.
- B. Be in HOT STANDBY.
- C. Perform 3-OSP-059.10, Quadrant Power Tilt Ratio Calculation.
- D. Perform 3-OSP-059.9, Computer Axial Flux Monitor Verification.

**Turkey Point Nuclear Plant 2011
Senior Reactor Operator License Examination**

21.

Given the following:

- Unit 3 is at 100% power.
- Boron Concentration is 450 ppm.
- Shutdown Margin (SDM) is 1.25% $\Delta k/k$.

Which ONE of the following describes the MINIMUM required actions, if any, by Technical Specification 3.1.1.1, Shutdown Margin - Tavg Greater than 200°F?

REFERENCE PROVIDED

- A. No Tech Spec actions are required.
- B. Immediately initiate RCS boration with at least 16 gpm.
- C. Immediately initiate an emergency boration with at least 45 gpm.
- D. Be in HOT STANDBY within 6 hours.

**Turkey Point Nuclear Plant 2011
Senior Reactor Operator License Examination**

22.

Given the following:

- A reactor startup is in progress on Unit 4.
- Tavg is 547°F.
- Control Bank "D" is at 50 steps.
- Both Source Range channels indicate approximately 2×10^3 CPS.
- Both Intermediate Range channels indicate approximately 3×10^{-11} amps.
- Source Range Channel N-31 fails LOW.
- Audio Count Rate Selector is selected to N-31.

Which ONE of the following describes whether the startup may continue in accordance with Technical Specifications and the reason?

- A. The startup may continue because Gammametrics are available.
- B. The startup may continue because the plant is above P-6.
- C. The startup may NOT continue because of a loss of the SR Audio Count Rate
- D. The startup may NOT continue because the plant is below P-6.

**Turkey Point Nuclear Plant 2011
Senior Reactor Operator License Examination**

23.

Given the following:

- Unit 3 is at 25% power and raising power.
- Annunciator INTERM RANGE N-35 LOSS OF COMP VOLTAGE (B 5/3) alarms.

Intermediate Range N-35 Drawer Indications

- N-35 Drawer – LOSS OF DETECTOR VOLT light is ON.
- N-35 Drawer – LOSS OF COMP. VOLT light is ON.
- N-35 Drawer – HIGH LEVEL TRIP light is ON.

For the given indications, which ONE of the following describes the indications on the INTERMEDIATE RANGE N-35 Drawer and status of the Reactor Trip Breakers?

	<u>Intermediate Range N-35 Drawer Indications</u>	<u>Reactor Trip Breakers</u>
A.	CONTROL POWER ON status light is OFF	are tripped
B.	CONTROL POWER ON status light is OFF	NOT tripped
C.	INSTRUMENT POWER ON status light is OFF	are tripped
D.	INSTRUMENT POWER ON status light is OFF	NOT tripped

**Turkey Point Nuclear Plant 2011
Senior Reactor Operator License Examination**

24.

Which two of the following Area Radiation Monitors are inputs to Control Room annunciator X 4/1, ARMS HI RADIATION?

- A. 1) U-3 Ctmnt High Range Rad. Monitors
AND
2) RAI-6642, Control Room HVAC Radiation Monitor
- B. 1) U-3 Ctmnt High Range Rad. Monitors
AND
2) U-4 New Fuel Storage Area
- C. 1) Spent Fuel Pit Exhaust Duct
AND
2) U-4 New Fuel Storage Area
- D. 1) Spent Fuel Pit Exhaust Duct
AND
2) RAI-6642, Control Room HVAC Radiation Monitor

**Turkey Point Nuclear Plant 2011
Senior Reactor Operator License Examination**

25.

Given the following:

The Control Room directs the ANPO to perform a Emergency/Manual Start of the Diesel Driven Fire Pump (DDFP).

The MINIMUM required action(s) to locally start the DDFP in accordance with 0-OP-016.1, Fire Protection Water System, Section 7.8, Emergency/Manual Start of the DDFP is/are to....

- A. Throttle open the Gauge Test Line Drain, 10-1054.
- B. Throttle closed the DDFP Mercoird Sensing Line Isolation Valve 10-769.
- C. Ensure Battery 1 & 2 Switches are ON, place the Control Switch to MANUAL, and push the CRANK 1 pushbutton.
- D. Ensure Battery 1 & 2 Switches are ON and push the CRANK 1 & CRANK 2 pushbuttons simultaneously.

**Turkey Point Nuclear Plant 2011
Senior Reactor Operator License Examination**

26.

Which ONE of the following describes the LOWEST S/G pressure that will meet the entry conditions of 3-EOP-FR-H.2, Response to Steam Generator Overpressure, and a required action listed in this procedure?

- A. 1075 psig; manually open the S/G Steam Dump to Atmosphere Valve
- B. 1135 psig; manually open the S/G Steam Dump to Atmosphere Valve
- C. 1075 psig; initiate S/G Blowdown flow from the affected S/G
- D. 1135 psig; initiate S/G Blowdown flow from the affected S/G

**Turkey Point Nuclear Plant 2011
Senior Reactor Operator License Examination**

27.

Given the following:

- A LOCA has occurred on Unit 3.
- RCS pressure is 100 psig.
- Containment pressure is 38 psig.
- Containment High Range Area Radiation Monitors (CHRRMS) are 6E5 R/HR.
- Actions of 3-EOP-FR-Z.3, Response to High Containment Radiation Level, are in progress.

In accordance with 3-EOP-FR-Z.3, which ONE of the following describes (1) the bases for starting Emergency Containment Filter Fans and (2) the reason for installing the Containment Purge Isolation Valve fuses?

- A. (1) To reduce the iodine concentration in the Containment atmosphere
(2) To verify the Containment Ventilation Isolation Valves are closed
- B. (1) To provide mixing and cooling of Containment atmosphere
(2) To lower Containment pressure when normal methods are unavailable
- C. (1) To reduce the iodine concentration in the Containment atmosphere
(2) To lower Containment pressure when normal methods are unavailable
- D. (1) To provide mixing and cooling of Containment atmosphere
(2) To verify the Containment Ventilation Isolation Valves are closed

**Turkey Point Nuclear Plant 2011
Senior Reactor Operator License Examination**

28.

Given the following:

- Unit 3 is operating at 100% power with all controls in Automatic.
- HIC-3-121, Charging Flow to Regen Hx Controller, is at 50% demand.

Which ONE of the following completes the following statement?

IF the pneumatic supply is lost to HCV-3-121, Charging Flow to Regen HX, THEN HCV-3-121 will fail to the fully _____ position, and the RCP seal injection flow rate will _____.

- A. (1) open
(2) rise
- B. (1) open
(2) lower
- C. (1) closed
(2) rise
- D. (1) closed
(2) lower

**Turkey Point Nuclear Plant 2011
Senior Reactor Operator License Examination**

29.

Given the following:

- Unit 4 is at 100% power.
- Pressurizer level is 55% and stable following IST on the 4A Charging Pump.
- Letdown Orifice CV-4-200C is in service.
- Excess Letdown is in service.
- VCT level is 30% and stable.

The crew places letdown orifice CV-4-200A in service to lower Pressurizer level.

Which ONE of the following identifies (1) if a CVCS Demineralizer Letdown flow design limit was exceeded after the second orifice was placed in service AND (2) the effect on Letdown flow if PCV-4-145, Low Pressure Letdown Valve, subsequently fails OPEN?

- A. (1) WAS exceeded
(2) Will initially rise
- B. (1) WAS NOT exceeded
(2) Will initially rise
- C. (1) WAS exceeded
(2) Will initially lower
- D. (1) WAS NOT exceeded
(2) Will initially lower

**Turkey Point Nuclear Plant 2011
Senior Reactor Operator License Examination**

30.

Given the following conditions:

- Unit 3 is in Mode 4 and shutting down for refueling.
- 3B RHR Cooling Train is in service.
- A tube leak occurs in the 3B RHR Exchanger.

Which ONE of the following identifies (1) a symptom of the tube leak and (2) assuming no operator action, the response of the RHR Hx Bypass Flow Valve, FCV-3-605?

- A. (1) CCW Head Tank level lowers
(2) Closes
- B. (1) CCW Head Tank level lowers
(2) Opens
- C. (1) RCS level lowers
(2) Closes
- D. (1) RCS level lowers
(2) Opens

**Turkey Point Nuclear Plant 2011
Senior Reactor Operator License Examination**

31.

Emergency Core Cooling System components operate in the following Modes of Operation: passive accumulator injection, _____ (1) _____, and cold/hot leg recirculation.

When these ECCS Modes of Operation are unavailable during a Large Break Loss of Coolant Accident, then the General Design Criteria of 10 CFR 50.46 could exceed the Peak Cladding Temperature Limit of _____ (2) _____.

(Assume NO operator action.)

- A. (1) hot leg injection
(2) 1800°F
- B. (1) hot leg injection
(2) 2200°F
- C. (1) cold leg injection
(2) 1800°F
- D. (1) cold leg injection
(2) 2200°F

**Turkey Point Nuclear Plant 2011
Senior Reactor Operator License Examination**

32.

Given the following:

- Unit 3 was initially at 100% power.
- RCS Activity level is 5.61×10^{-2} $\mu\text{Ci/gm}$.
- A Reactor Trip and Safety Injection (SI) occurred due to Pressurizer Safety Valve RV-3-551B failing open.
- PRT pressure was 85 psig and rising steadily.

Which ONE of the following predicts Containment conditions within the next hour?

- A. Containment Sump levels will remain constant
Containment Conditions will become ADVERSE
- B. Containment Sump levels will rise
Containment Conditions will become ADVERSE
- C. Containment Sump levels will remain constant
Containment Conditions will NOT become ADVERSE
- D. Containment Sump levels will rise
Containment Conditions will NOT become ADVERSE

**Turkey Point Nuclear Plant 2011
Senior Reactor Operator License Examination**

33.

Unit 3 is at 100% power.

- Total CCW Thermal Barrier Return Flow is 85 gpm.

Subsequently,

- The 3A RCP Thermal Barrier Heat Exchanger develops a leak of 25 gpm.
- CCW Head Tank Level is 80% and slowly rising.
- PRMS HI RADIATION H 1/4 is in alarm due to CCW Radiation Monitor R-3-17A/B.

Which ONE of the following states (1) the position of RCV-3-609, Head Tank Vent Valve, and (2) the position of MOV-3-626, RCP Thermal Barrier Return Isolation Valve, based on the above conditions?

- A. (1) open
(2) open
- B. (1) open
(2) closed
- C. (1) closed
(2) open
- D. (1) closed
(2) closed

**Turkey Point Nuclear Plant 2011
Senior Reactor Operator License Examination**

34.

Given the following:

- Unit 3 is operating at 50% power.
- ALL Pressurizer pressure controls are in AUTO.
- PT-3-444, Pressurizer Pressure Transmitter, fails LOW.

Which ONE of the choices below completes the following sentence?

With no operator action over the next half hour, Unit 3 will ____ (1) ____ and RCS pressure will cycle around ____ (2) ____.

- A. (1) trip
(2) PORV PCV-3-456 Setpoint
- B. (1) trip
(2) PORV PCV-3-455C Setpoint
- C. (1) remain at power
(2) PORV PCV-3-456 Setpoint
- D. (1) remain at power
(2) PORV PCV-3-455C Setpoint

**Turkey Point Nuclear Plant 2011
Senior Reactor Operator License Examination**

35.

In accordance with 0-ADM-536, Technical Specification Bases Control Program, which ONE of the following Reactor Trip Setpoints provides reactor core protection against Departure from Nucleate Boiling (DNB)?

- A. Steam/Feedwater Flow Mismatch and Low Steam Generator Water Level
- B. Reactor Coolant Pump Breaker Position Trip
- C. Pressurizer Water Level
- D. Power Range Neutron Flux – Low Range

**Turkey Point Nuclear Plant 2011
Senior Reactor Operator License Examination**

36.

Given the following:

- Unit 3 is at 100% power.
- Pressurizer Pressure is at 2235 psig.
- Pressurizer Pressure Protection Channel PT-3-455 failed.
- All actions of 3-ONOP-049.1, Deviation or Failure of Safety Related or Reactor Protection Channels, were completed.

Which ONE of the following identifies (1) the status of the permissive "BLOCK LOW PRZ. PRESS. S.I." light on VPA and (2) the MINIMUM number of additional Pressurizer Pressure Channels required to automatically actuate a Safety Injection on Pressurizer Low Pressure?

	<u>Block Light (permissive)</u>	<u>Channels</u>
A.	On	One
B.	On	Two
C.	Off	One
D.	Off	Two

**Turkey Point Nuclear Plant 2011
Senior Reactor Operator License Examination**

37.

Given the following:

- Unit 3 is at 100% power.
- An automatic Safety Injection occurs.

Which ONE of the following identifies (1) the Emergency Containment Coolers (ECCs) which will receive an automatic start signal and (2) the position of the associated CCW Cooling Water Outlet Valve if one of these ECCs fails to start?

- A. (1) 3A and 3C ECC
(2) closed
- B. (1) 3A and 3C ECC
(2) open
- C. (1) 3B and 3C ECC
(2) closed
- D. (1) 3B and 3C ECC
(2) open

**Turkey Point Nuclear Plant 2011
Senior Reactor Operator License Examination**

38.

Given the following:

- Unit 4 was operating at 100% power.
- Unit 4 has experienced a Loss of Coolant Accident (LOCA) with a Loss of Offsite Power (LOOP).
- The crew has entered to 4-EOP-E-1, Loss of Reactor or Secondary Coolant.
- RCS pressure lowered to 475 psig.
- Containment pressure peaked at 22 psig and is now 13 psig and lowering.

In accordance with 4-EOP-E-1, Loss of Reactor or Secondary Coolant, which ONE of the following identifies (1) the temperature at which the Containment Spray Pump must be stopped and (2) the time when two Emergency Containment Coolers are required to be in operation?

	<u>Containment Temperature</u>	<u>Time After LOCA Initiation</u>
A.	<180°F	12 hrs
B.	<122°F	24 hrs
C.	<180°F	24 hrs
D.	<122°F	12 hrs

**Turkey Point Nuclear Plant 2011
Senior Reactor Operator License Examination**

39.

Which ONE of the following completes the statement below with respect to how the High Main Steam Line Flow with Low Tavg Isolation Setpoint changes with power?

The isolation setpoint is _____ steam flow at _____ power and then increases linearly to about 120% steam flow at 100% power.

- A. 40%; 0%
- B. 20%; 0%
- C. 40%; 20%
- D. 20%; 20%

**Turkey Point Nuclear Plant 2011
Senior Reactor Operator License Examination**

40.

Given the following:

- Unit 4 experienced a Reactor Trip from 100% power due to a failed open Main Feedwater Regulating Valve.
- A Feedwater Isolation Signal was generated.

With repairs complete, Unit 4 is preparing for startup:

- S/G Narrow Range Levels are 45%, 55%, 68% and stable.
- Tave is 543°F and stable.
- Pressurizer Pressure is 2235 psig and stable.

Which ONE of the following describes the MINIMUM action(s) necessary to reset the Main Feedwater Regulating Valve's SLOW Close Solenoid?

- A. Reset Feedwater Bypass Isolation using the pushbuttons on VPB ONLY
- B. Close the Reactor Trip Breakers ONLY
- C. Close the Reactor Trip Breakers AND Reset Feedwater Bypass Isolation using the pushbuttons on VPB ONLY
- D. Raise Tave to greater than 554°F, close the Reactor Trip Breakers, AND Reset Feedwater Bypass Isolation using the pushbuttons on VPB

**Turkey Point Nuclear Plant 2011
Senior Reactor Operator License Examination**

41.

Given the following:

- Unit 4 was operating at 100% power.
- A Reactor Trip due to a Loss of Main Feedwater.
- 4B 4KV Bus is locked out.
- Due to equipment malfunctions, ONLY 'A' AFW Pump is in service.
- The 'A' AFW Pump speed has begun to slowly LOWER due to a malfunctioning governor.

Which ONE of the following describes how the change in AFW flow will affect Pressurizer Level, including the reason?

Indicated Pressurizer Level will initially ...

- A. rise due to a bubble formation in the Rx Vessel Head
- B. rise due to decreased primary to secondary heat transfer
- C. lower due to the density change in the RCS
- D. lower due to decreasing Charging flow

**Turkey Point Nuclear Plant 2011
Senior Reactor Operator License Examination**

42.

Given the following:

- Unit 3 is operating at 100% power.
- 3D 4KV Bus is aligned to the 3A 4KV Bus.
- A Loss of Offsite Power occurs.
- A 3A 4KV Bus undervoltage condition occurs and clears after 15 seconds.
- During the transient, the Supply From 4KV Bus 3A, 3AD01, trips OPEN.

(Assume no operator action.)

Which ONE of the following lists the components that have lost their power supply?

- A. Component Cooling Water Pump 3C and Emergency Containment Filter Fan 3C
- B. Intake Cooling Water Pump 3A and Emergency Containment Cooler Fan 3C
- C. Intake Cooling Water Pump 3C and Component Cooling Water Pump 3C
- D. Emergency Containment Filter Fan 3A and Emergency Containment Cooler Fan 3C

**Turkey Point Nuclear Plant 2011
Senior Reactor Operator License Examination**

43.

In accordance with 0-NOP-003.01, 125V Vital DC System, which ONE of the choices below completes the following statements?

If two battery chargers are connected to the battery bank, each battery charger is required to have a minimum output of (1) amps.

The 125 VDC Battery Terminal MINIMUM Voltage is required to be greater than or equal to (2) VDC.

- A. (1) 10
 (2) 129

- B. (1) 10
 (2) 105

- C. (1) 20
 (2) 129

- D. (1) 20
 (2) 105

**Turkey Point Nuclear Plant 2011
Senior Reactor Operator License Examination**

44.

Given the following:

- Unit 3 is operating at 100%.
- 3A Emergency Diesel Generator (EDG) has been started manually from the control room in accordance with 3-OSP-023.1, Diesel Generator Operability Test.

Which ONE of the following completes the following statements?

In accordance with 3-OSP-23.1 the desired ratio of load (watts) to reactive load (vars) is required to be maintained approximately (1) .

The generator is operated in the LAG position to protect against (2) .

- A. (1) 1:1
 (2) overheating generator windings
- B. (1) 1:1
 (2) disruption of the rotor/stator coupled magnetic field
- C. (1) 2:1
 (2) disruption of the rotor/stator coupled magnetic field
- D. (1) 2:1
 (2) overheating generator windings

**Turkey Point Nuclear Plant 2011
Senior Reactor Operator License Examination**

45.

Which ONE of the following describes (1) an initiating signal to cause a Control Room Ventilation Isolation and (2) the order in which the Emergency Air Supply Fans, SF-1A (V-29A) and SF-1B (V-29B) start in Recirculation mode?

- A. (1) RAI-6642, Control Room HVAC Radiation Monitor high alarm
(2) SF-1A starts first, SF-1B starts only on LOW flow
- B. (1) RI-1420B, Unit 3 & 4 Control Room Area Radiation Monitor high alarm
(2) SF-1A starts first, SF-1B starts only on LOW flow
- C. (1) RAI-6642, Control Room HVAC Radiation Monitor high alarm
(2) SF-1B starts first, SF-1A starts only on LOW flow
- D. (1) RI-1420B, Unit 3 & 4 Control Room Area Radiation Monitor high alarm
(2) SF-1B starts first, SF-1A starts only on LOW flow

**Turkey Point Nuclear Plant 2011
Senior Reactor Operator License Examination**

46.

Which ONE of the choices completes the statement below regarding limitations placed on the Intake Cooling Water Pump in accordance with 3-NOP-019, Intake Cooling Water System?

If an ICW Pump has a MAXIMUM flow greater than (1) gpm for more than twenty minutes, then the MINIMUM required action(s) is/are to (2) .

- A. (1) 10,000
(2) reduce ICW flow as soon as possible. NO pump vibration and d/p testing is required
- B. (1) 10,000
(2) reduce ICW flow as soon as possible AND perform pump vibration and d/p testing
- C. (1) 18,500
(2) reduce ICW flow as soon as possible. NO pump vibration and d/p testing is required
- D. (1) 18,500
(2) reduce ICW flow as soon as possible AND perform pump vibration and d/p testing

**Turkey Point Nuclear Plant 2011
Senior Reactor Operator License Examination**

47.

Given the following:

- The Motor Driven Air Compressor (3CM) is in LEAD.
- The Motor Driven Air Compressor (4CM) is OOS.
- The Diesel Driven Air Compressor (3CD) is in LAG.

Subsequently the following events occur,

- 0100: A valve alignment error caused Instrument Air header pressure to drop to 88 psig.
- 0115: The error was discovered and corrected.
- 0130: Instrument Air header pressure is 94 psig and rising.

Which ONE of the following identifies the status of the Instrument Air Compressors at 0130?

- A. 3CD off; 3CM running loaded
- B. 3CD running unloaded; 3CM running loaded
- C. 3CD running loaded; 3CM running unloaded.
- D. 3CD running loaded; 3CM running loaded

**Turkey Point Nuclear Plant 2011
Senior Reactor Operator License Examination**

48.

Given the following:

- Unit 3 was at 100% power.
- A manual Reactor Trip was initiated.
- A manual Safety Injection was initiated.
- Containment Pressure is 10.0 psig
- ONLY one Containment Phase A pushbutton was depressed.

Which ONE of the following correctly describes the status of the Phase A and Phase B isolation valves BEFORE any additional operator action(s)?

- A. NOT all Phase A valves are closed; all Phase B valves are closed.
- B. NOT all Phase A valves are closed; all Phase B valves are open.
- C. All Phase A valves are closed; all Phase B valves are closed.
- D. All Phase A valves are closed; all Phase B valves are open.

**Turkey Point Nuclear Plant 2011
Senior Reactor Operator License Examination**

49.

Initial conditions:

- Unit 4 is operating at 100% power.
- Annunciator SEAL WATER INJ FILTER HI ΔP (A 6/6) actuates.
- Local investigation indicates that the ΔP is 23 psid.
- RCP seal injection flow is 6.5 GPM per RCP.

Current conditions:

- Standby Seal Water Injection filter was placed in service.
- Filter ΔP is 24 psid.
- RCP Seal Injection flow is 5 GPM per RCP.

Which ONE of the following describes (1) the action required and (2) the impact on RCP operation in accordance with ARP A 6/6 and 3-ONOP-041.1, Reactor Coolant Pump Off-Normal?

- A. (1) Bypass the Seal Water Injection Filters
(2) RCPs may be operated indefinitely if CCW is available
- B. (1) Isolate Seal Injection
(2) RCPs may be operated indefinitely if CCW is available
- C. (1) Bypass the Seal Water Injection Filters
(2) RCPs may ONLY be run for 24 hours without Seal Injection even if CCW is available.
- D. (1) Isolate Seal Injection
(2) RCPs may ONLY be run for 24 hours without Seal Injection even if CCW is available.

**Turkey Point Nuclear Plant 2011
Senior Reactor Operator License Examination**

50.

Given the following:

- Unit 3 is at 100% power.
- Both of the Pressurizer Backup Heater Groups were manually placed in the "ON" position one hour ago for RCS boron equalization.
- Subsequently, PCV-3-455A, Spray Control Valve, fails to 100% OPEN.

With NO operator action, which ONE of the following completes the statement below?

PCV-3-455B Spray Valve _____ and the reactor will_____.

- A. closes; trip
- B. closes; remain at power
- C. remains open; trip
- D. remains open; remain at power

**Turkey Point Nuclear Plant 2011
Senior Reactor Operator License Examination**

51.

The (1) RPS Trip provides core protection from Departure from Nucleate Boiling (DNB).

The trip setpoint is automatically reduced when RCS pressure (2).

- | | | |
|----|----------------------------|------------|
| | <u>(1)</u> | <u>(2)</u> |
| A. | Overpower ΔT | rises |
| B. | Overtemperature ΔT | rises |
| C. | Overpower ΔT | lowers |
| D. | Overtemperature ΔT | lowers |

**Turkey Point Nuclear Plant 2011
Senior Reactor Operator License Examination**

52.

Which ONE of the following identifies the power supply to 3A EDG Sequencer, and an operational implication when this power supply is lost?

- A. 3P07; associated AFW actuation signal is lost
- B. 3P07; associated EDG will fail to auto start on undervoltage
- C. 3P06; associated AFW actuation signal is lost
- D. 3P06; associated EDG will fail to auto start on undervoltage

**Turkey Point Nuclear Plant 2011
Senior Reactor Operator License Examination**

53.

The CCW flow rate to a Containment Spray Pump Seal Water Heat Exchanger is pre-adjusted to _____.

The CSP A/B COOLING WATER LO FLOW annunciator (H 7/5) setpoint is _____.

- A. 38 gpm; 5.0 gpm
- B. 15 gpm; 7.7 gpm
- C. 15 gpm; 5.0 gpm
- D. 38 gpm; 7.7 gpm

**Turkey Point Nuclear Plant 2011
Senior Reactor Operator License Examination**

54.

Given the following condition:

- Unit 3 is in MODE 1 and all Vital AC Systems are in their normal lineups.
- 3P06 Panel lost power and remained de-energized.

Which ONE of the following completes the statements below?

In accordance with 3-ONOP-003.6, Loss of 120V Vital Instrument Panel 3P06, Panel 3P06 is required to be re-energized from the (1).

In accordance with Technical Specification 3.8.3.1 Onsite Power Distribution, the LCO is (2) after 3P06 is re-energized.

- A. (1) CS Spare Inverter
(2) Met
- B. (1) CS Spare Inverter
(2) NOT Met
- C. (1) Constant Voltage Transformer (CVT)
(2) Met
- D. (1) Constant Voltage Transformer (CVT)
(2) NOT Met

**Turkey Point Nuclear Plant 2011
Senior Reactor Operator License Examination**

55.

Given the following:

- Unit 4 is operating in Mode 3.
- All equipment is operating in a normal lineup.
- The 125 VDC Control Power FU1-UT-P Fuse to 4A RCP Breaker (4AA01) is blown.
- Main Control Board breaker indicating lights for 4A RCP are extinguished.

Which ONE of the following choices identifies (1) the status of the local breaker position indicating lights for 4A RCP Breaker (4AA01) and (2) the effect on the 4A RCP Breaker (4AA01) operation?

REFERENCE PROVIDED

- A. (1) Local indicating lights are EXTINGUISHED for 4A RCP Breaker (4AA01).
(2) The 4A RCP Breaker (4AA01) will ONLY open by depressing the Manual Trip Latch on the local breaker.
- B. (1) Local indicating lights are EXTINGUISHED for 4A RCP Breaker (4AA01).
(2) The 4A RCP Breaker (4AA01) can be opened locally by placing the NORMAL/ISOLATE switch in ISOLATE and operating the Test Switch for the breaker.
- C. (1) Local indicating lights are LIT for 4A RCP Breaker (4AA01).
(2) The 4A RCP Breaker (4AA01) will ONLY open by depressing the Manual Trip Latch on the local breaker.
- D. (1) Local indicating lights are LIT for 4A RCP Breaker (4AA01).
(2) The 4A RCP Breaker (4AA01) can be opened locally by placing the NORMAL/ISOLATE switch in ISOLATE and operating the Test Switch for the breaker.

**Turkey Point Nuclear Plant 2011
Senior Reactor Operator License Examination**

56.

Unit 3 is at 100% power.

3B S/G Steam Dump To Atmosphere Valve, CV-3-1607, fails open.

The 3B RCS Loop ΔT will rise due to (1).

In accordance with 0-ADM-200, Conduct of Operations, the required operator action to turn and reduce power below 100% is to (2).

- A. (1) That initially rising
(2) insert Control Rods
- B. (1) Tcold initially lowering
(2) insert Control Rods
- C. (1) Tcold initially lowering
(2) reduce Turbine load
- D. (1) That initially rising
(2) reduce Turbine load

**Turkey Point Nuclear Plant 2011
Senior Reactor Operator License Examination**

57.

Given the following:

- The plant is operating at 88% power.
- Tref is 571°F.
- Rod Control is in MANUAL.
- Control Bank D rods are at 200 steps.

RCS Tavg Channels

- TI-3-412D, A Loop Temp Avg.: 574.8°F
- TI-3-422D, B Loop Temp Avg.: 575.0°F
- TI-3-432D, C Loop Temp Avg.: 575.2°F

Which ONE of the following completes the statement if the Rod Control Bank Select Switch is placed to the AUTO position?

Rods will initially move at _____ and will stop as soon as the difference between Tavg and Tref is _____.

- A. 68 SPM; 1.0°F
- B. 68 SPM; 1.5°F
- C. 40 SPM; 1.0°F
- D. 40 SPM; 1.5°F

**Turkey Point Nuclear Plant 2011
Senior Reactor Operator License Examination**

58.

Which ONE of the following identifies (1) the pressure input to the Subcooled Margin Monitor, and (2) the Core Exit Thermocouple input value used for the associated QSPDS Subcooling Train?

- A. (1) Wide Range RCS Pressure
(2) the average of all Core Exit Thermocouple temperatures
- B. (1) Narrow Range Pressurizer Pressure
(2) the average of all Core Exit Thermocouple temperatures
- C. (1) Wide Range RCS Pressure
(2) the average of the three highest Core Exit Thermocouple temperatures
- D. (1) Narrow Range Pressurizer Pressure
(2) the average of the three highest Core Exit Thermocouple temperatures

**Turkey Point Nuclear Plant 2011
Senior Reactor Operator License Examination**

59.

Given the following:

- Unit 3 is at 100% power.
- A Containment entry will be performed in accordance with 0-ADM-009, Containment Entries When Containment Integrity Is Established.
- A Unit 3 Containment Purge is ongoing in accordance with 3-NOP-053, Containment Purge System with the following fans running:
 - 3V9, U-3 Cntmt Purge Supply Fan
 - 4V20, U-4 Cntmt Purge Exhaust Fan
- 5 minutes after Containment is entered, R-3-12, Gaseous Containment Radiation Monitor, alarms high.
- H 1/4, PRMS Hi Radiation, annunciator is lit.

Which ONE of the following completes the statement below?

Containment entry ____ (1) ____.

The status of the Containment Purge Supply and Exhaust Fans are ____ (2) ____.

(Assume no operator actions.)

- A. (1) may not proceed
(2) 3V9, U-3 Cntmt Purge Supply Fan, is running
4V20, U-4 Cntmt Purge Exhaust Fan, is tripped
- B. (1) may not proceed
(2) 3V9, U-3 Cntmt Purge Supply Fan, is tripped
4V20, U-4 Cntmt Purge Exhaust Fan, is running
- C. (1) may proceed
(2) 3V9, U-3 Cntmt Purge Supply Fan, is running
4V20, U-4 Cntmt Purge Exhaust Fan, is tripped
- D. (1) may proceed
(2) 3V9, U-3 Cntmt Purge Supply Fan, is tripped
4V20, U-4 Cntmt Purge Exhaust Fan, is running

**Turkey Point Nuclear Plant 2011
Senior Reactor Operator License Examination**

60.

Given the following:

- Unit 3 is at 100% power.
- Turbine First Stage Pressure transmitter 3-PT-447 fails low.
- All applicable actions in 3-ONOP-049.1, "Deviation or Failure of Safety Related or Reactor Protection Channels" have been completed.

Which ONE of the following identifies the status of the Condenser Steam Dumps?

- A. Steam Dumps are reset and can ONLY be armed by a turbine trip.
- B. Steam Dumps are reset and can ONLY be armed by a load reject.
- C. Steam Dumps are armed and will actuate if Tave exceeds Tref by 9.5°F.
- D. Steam Dumps are armed and, if actuated, will close when Tave is within 5°F of Tref.

**Turkey Point Nuclear Plant 2011
Senior Reactor Operator License Examination**

61.

Given the following conditions:

- Unit 4 is at 25% power with all systems in normal alignments.
- 4A Main Steam Isolation Valve closes on a spurious signal.

Assuming the reactor does NOT trip, which ONE of the following describes the INITIAL effect (1) on 4A S/G indicated Level and (2) on the S/G Feedwater Regulating Valve (FRV) response for 4B and 4C S/Gs?

	<u>4A S/G Indicated Level</u>	<u>4B/4C FRV position</u>
A.	higher	open more
B.	higher	closed more
C.	lower	closed more
D.	lower	open more

**Turkey Point Nuclear Plant 2011
Senior Reactor Operator License Examination**

62.

Given the following:

- Unit 4 is in STARTUP at 7% power.
- The Steam Dump Control MODE SELECTOR Switch on the Control Room Console is in the MAN position.
- The Steam Pressure Controller is in automatic.
- The Steam Pressure Controller demand is at 30%.

Which ONE of the following listed below describes (1) the Condenser Steam Dump(s) that are armed and (2) the Condenser Steam Dump Valve(s) position?

	<u>ARMED</u>	<u>POSITION</u>
A.	ONLY CV-2827	PARTIALLY OPEN
B.	ONLY CV-2827	FULLY OPEN
C.	BOTH CV-2827 & CV-2828	CV-2827 IS FULLY OPEN CV-2828 IS PARTIALLY OPEN
D.	BOTH CV-2827 & CV-2828	BOTH CV-2827 & CV-2828 ARE PARTIALLY OPEN

**Turkey Point Nuclear Plant 2011
Senior Reactor Operator License Examination**

63.

The initial conditions on Unit 3:

- This is the first plant startup after a refueling outage.
- Moderator Temperature Coefficient (MTC) is slightly positive.
- The unit is at 8% power.
- Control Rods are in Manual.

Which ONE of the following predicts the INITIAL response of RCS Tavg and Reactor Trip Breakers, if the Main Turbine is manually tripped?

	<u>RCS Tavg</u>	<u>Reactor Trip Breakers</u>
A.	Rises	Remain Closed
B.	Rises	Trip Open
C.	Lowers	Remain Closed
D.	Lowers	Trip Open

**Turkey Point Nuclear Plant 2011
Senior Reactor Operator License Examination**

64.

Unit 3 has experienced a slow loss of Main Condenser vacuum with the current conditions listed below:

- Main Condenser vacuum is at 23" Hg and stable.
- E 5/3, CONDENSER LO VACUUM, annunciator is LIT.
- Main Turbine load at 300 MW.

Which ONE of the following identifies (1) the required IMMEDIATE operator action in accordance with 3-ONOP-014, Main Condenser Loss of Vacuum, and (2) whether the Reactor is required to be manually tripped?

- A. (1) Place the standby set of Air Ejectors in service.
(2) Reactor Trip is NOT required.
- B. (1) Place the SJAE Hogging Jet in service.
(2) Reactor Trip is NOT required.
- C. (1) Place the standby set of Air Ejectors in service.
(2) Trip the Reactor.
- D. (1) Place the SJAE Hogging Jet in service.
(2) Trip the Reactor.

**Turkey Point Nuclear Plant 2011
Senior Reactor Operator License Examination**

65.

Which ONE of the choices below correctly completes the following statements regarding preparing for a liquid release?

In accordance with 0-NCOP-003, Attachment 1 – Radioactive Release Permit, a MINIMUM of _____ (1) _____ hour(s) recirc time is required when using the 1" mini recirc on Waste Monitor Tanks.

If the WMT recirc time was too short, and the chemist's specific activity result was less than actual, then this will cause the _____ (2) _____.

- A. (1) one
(2) total calculated activity released will be higher than listed on the radioactive discharge permit
- B. (1) two
(2) discharge flowrate requirement listed on the radioactive discharge permit to be lower than it should be
- C. (1) two
(2) total calculated activity released will be higher than listed on the radioactive discharge permit
- D. (1) one
(2) discharge flowrate requirement listed on the radioactive discharge permit to be lower than it should be

**Turkey Point Nuclear Plant 2011
Senior Reactor Operator License Examination**

66.

Unit 4 is Operating in Mode 1.

In accordance with 0-ADM-202, Shift Relief and Turnover, which ONE of the following describes the MINIMUM requirement to review (1) the Special Instructions Book and (2) active clearances back to the last shift worked?

- A. (1) prior to assuming EACH shift watch;
(2) prior to assuming EACH shift watch
- B. (1) prior to assuming EACH shift watch;
(2) as soon as is practical after shift turnover
- C. (1) as soon as is practical after shift turnover;
(2) prior to assuming EACH shift watch
- D. (1) as soon as is practical after shift turnover;
(2) as soon as is practical after shift turnover

**Turkey Point Nuclear Plant 2011
Senior Reactor Operator License Examination**

67.

Which ONE of the following completes both statements with respect to the ATWS Mitigation System Actuation Circuitry (AMSAC)?

The AMSAC initiation logic is designed such that it _____.

Once armed, AMSAC will actuate after S/G Levels are $< 8.65\%$ for _____.

- A. Energizes to actuate; 360 seconds
- B. De-energizes to actuate; 360 seconds
- C. Energizes to actuate; 25 seconds
- D. De-Energizes to actuate; 25 seconds

**Turkey Point Nuclear Plant 2011
Senior Reactor Operator License Examination**

68.

Given the following:

- A loss of instrument air is in progress on Unit 3.
- Instrument Air header pressure is currently 83 psig and lowering slowly as read on PI-3-1444.

Which ONE of the following describes the CURRENT status of (1) CV-3-1605, Distribution Header Pressure Control Valve and (2) the INSTR AIR SYSTEM HI TEMP/PRESS LOW (I 6/1) annunciator?

- A. (1) CLOSING
(2) Alarm is NOT lit.
- B. (1) OPENING
(2) Alarm is NOT lit.
- C. (1) CLOSING
(2) Alarm is lit.
- D. (1) OPENING
(2) Alarm is lit.

**Turkey Point Nuclear Plant 2011
Senior Reactor Operator License Examination**

69.

In accordance with Technical Specification Safety Limit 2.1.2, Reactor Coolant System Pressure, the Reactor Coolant System pressure shall NOT exceed _____.

IF the limit is exceeded when the unit is in Mode 3, THEN RCS pressure must be reduced to within its limit within _____.

- A. 2485 psig; 5 minutes
- B. 2485 psig; 1 hour
- C. 2735 psig; 5 minutes
- D. 2735 psig; 1 hour

**Turkey Point Nuclear Plant 2011
Senior Reactor Operator License Examination**

70.

Given the following:

- Unit 4 is in a refueling outage.
- A clearance order will defeat a Control Room annunciator associated with a required RHR Pump (pump is required to be operable).

In accordance with 0-ADM-219, Annunciator Response Procedure Usage, which ONE of the choices below completes both statements?

The MINIMUM requirement for tracking the defeated annunciator is in the ____ (1) ____.

The applicable portions of 0-OSP-200.5, Miscellaneous Tests, and Operating Evolutions, for Defeated/Out-Of-Service Annunciators must be completed ____ (2) ____.

- A. (1) Annunciator Status Log ONLY
(2) within ONE hour after the annunciator has been disabled
- B. (1) Annunciator Status Log ONLY
(2) PRIOR to defeating the annunciator
- C. (1) Annunciator Status Log and Equipment Out of Service Book (EOOS)
(2) within ONE hour after the annunciator has been disabled
- D. (1) Annunciator Status Log and Equipment Out of Service Book (EOOS)
(2) PRIOR to defeating the annunciator

**Turkey Point Nuclear Plant 2011
Senior Reactor Operator License Examination**

71.

Given the following:

- A Steam Generator Tube Rupture has occurred on Unit 3.
- The operating crew has implemented 3-EOP-E-3, Steam Generator Tube Rupture and has prepared for RCS cooldown using Steam Dumps To Condenser.
- The crew desires to stop Auxiliary Feedwater Pumps.

Which ONE of the following identifies the PREFERRED method of providing feedwater to the SGs during the cooldown, including the reason for this preference, in accordance with 3-EOP-E-3?

- A. Standby Feedwater System; The volume of contaminated secondary water released to the environment (post tube rupture) will be less.
- B. Standby Feedwater System; The amount of radioactivity released via an unmonitored pathway (during RCS cooldown) will be less.
- C. Normal Feedwater System; The volume of contaminated secondary water released to the environment (post tube rupture) will be less.
- D. Normal Feedwater System; The amount of radioactivity released via an unmonitored pathway (during RCS cooldown) will be less.

**Turkey Point Nuclear Plant 2011
Senior Reactor Operator License Examination**

72.

Unit 3 is in a refueling outage and fuel assemblies are being moved from the core to the Spent Fuel Pool.

Which ONE of the subsequent plant conditions will require the control room operator to evacuate non-essential personnel from the Unit 3 Containment?

- A. Containment Integrity is lost
- B. Unit 3 Containment Purge Supply Fan (3V9) trips
- C. Source Range N-31 fails low
- D. Containment Air Particulate Monitor R-3-11 red LED light illuminates

**Turkey Point Nuclear Plant 2011
Senior Reactor Operator License Examination**

73.

Which ONE of the following identifies a plant parameter that is required to determine the status of the **Heat Sink** Critical Safety Function (CSF) in accordance with EOP-F-0, Critical Safety Function Status Trees?

- A. Total FW flow
- B. Core Exit Thermocouple temperatures
- C. RCS Subcooling
- D. RCS Cold Leg temperatures

**Turkey Point Nuclear Plant 2011
Senior Reactor Operator License Examination**

74.

Which ONE of the following choices identifies a Control Board Instrument required by Technical Specification 3.3.3.3, Accident Monitoring Instrumentation, and the required color of the instrument label in accordance with 0-ADM-209, Equipment Tagging and Labeling?

- A. PI-3-444, Pressurizer Pressure; blue
- B. PI-3-444, Pressurizer Pressure; purple
- C. TI-3-410A, Loop A T-cold Wide Range; blue
- D. TI-3-410A, Loop A T-cold Wide Range; purple

**Turkey Point Nuclear Plant 2011
Senior Reactor Operator License Examination**

75.

Given the following:

- Unit 3 is in Mode 5 for a refueling outage.
- 3A RHR Train is in operation for shutdown cooling.
- Time to boil in the reactor vessel is 2 hrs.
- No extensions are authorized for the containment closure time limit in accordance with 0-ADM-051, Outage Risk Assessment and Control.

Subsequently,

- ALL running CCW Pumps are tripped after showing signs of cavitation.
- RCS temperature is rising, and the crew enters 3-ONOP-050, Loss of RHR.

Which ONE of the following identifies (1) how often RCS Heatup Rate is required to be calculated (2) the MAXIMUM time allowed prior to setting Containment Closure after RHR lost in accordance with 3-ONOP-050, Loss of RHR?

- A. (1) every 30 minutes
(2) 30 minutes
- B. (1) every 30 minutes
(2) 2 hrs
- C. (1) every 15 minutes
(2) 2 hrs
- D. (1) every 15 minutes
(2) 30 minutes

**Turkey Point Nuclear Plant 2011
Senior Reactor Operator License Examination**

76.

The following conditions exist:

- Unit 3 tripped from 100% power due to a Loss of All Feedwater.
- All HHSI Pumps are unavailable.
- The Unit 3 PORVs are cycling.

After 30 minutes into this event:

- The crew has not been able to restore any feedwater to all S/Gs.
- Unit 3 S/G Wide Range Levels are all at 5%.
- Seven of the highest Core Exit Thermocouples (CETs) are rising and temperatures are as follows: 2200°F, 2210°F, 1210°F, 1207°F, 1201°F, 1170°F, and 1151°F.
- RVLMS Plenum indicates 0%.
- CHRRMS is 2.0E4 R/hr.

Which ONE of the following describes the (1) required functional restoration procedure to immediately transition to and (2) highest required emergency classification?

REFERENCE PROVIDED

- A. (1) 3-EOP-FR-C.2, Response to Degraded Core Cooling
(2) Site Area Emergency
- B. (1) 3-EOP-FR-C.1, Response to Inadequate Core Cooling
(2) General Emergency
- C. (1) 3-EOP-FR-C.2, Response to Degraded Core Cooling
(2) General Emergency
- D. (1) 3-EOP-FR-C.1, Response to Inadequate Core Cooling
(2) Site Area Emergency

**Turkey Point Nuclear Plant 2011
Senior Reactor Operator License Examination**

77.

Unit 3 is in MODE 5 and drained down for Reduced Inventory Operations with the following:

- The RCS is depressurized at 100°F.
- RCS Heatup Rate is 9°F/ hr.
- S/G 3A, 3B and 3C Narrow Range Levels are at 20%.
- The Equipment Hatch is open.
- The following alarms are received in the Control Room:
 - H 6/2, RHR HX HI/LO FLOW
 - I 8/6, RHR SUMP PUMP ROOM A HI LEVEL.
- PZR Cold Cal Level, LI-3-462 is off-scale low.
- PZR Drain Down Levels, LI-3-6421 and LI-3-6423, are 12% and stable.
- RHR Pump 3A was manually tripped in 3-ONOP-050, Loss of RHR.

Which ONE of the following describes (1) if 3-ONOP-041.8 Shutdown LOCA [Mode 5 or 6], Attachment 2, Feed and Bleed Cooling, is required (2) and the highest required emergency classification?

REFERENCE PROVIDED

- A. (1) is required
(2) Site Area Emergency
- B. (1) is required
(2) Alert
- C. (1) is not required
(2) Site Area Emergency
- D. (1) is not required
(2) Alert

**Turkey Point Nuclear Plant 2011
Senior Reactor Operator License Examination**

78.

A Unit 3 RCS cooldown is in progress with the following:

- Unit 3 was shutdown 5 days ago.
- RCS Temperature is 105°F.
- RCS Pressure is 160 psig.
- RHR Pump 3A is in service.
- RHR Pump 3B is in Standby.
- CCW Pump 3C is out of service.
- Pressurizer level is 22%.
- S/G levels are 35% Narrow Range on all three S/Gs.

When,

- RHR Pump 3A trips.
- RHR Pump 3B is started.
- RCS Temperature is 115 °F.
- RCS Pressure is maintained greater than 150 psig.

In accordance with ADM-051, Outage Risk Assessment and Control, which ONE of the following is (1) the Enclosure that identifies the required Unit 3 Contingency Actions for Decay Heat Removal, given the initial plant status, and (2) the required Safe Shutdown Function Color Code for Decay Heat Removal AFTER the 3A RHR Pump tripped?

- A. (1) **Enclosure 1**, Minimum Required Equipment, Phase I, Large Decay Heat Load and RCS Temp Less Than 200 Degrees with RCS Loops Filled
(2) Orange
- B. (1) **Enclosure 2**, Minimum Required Equipment, Phase I, Large Decay Heat Load and RCS Temp Less Than 200 Degrees without RCS Loops Available
(2) Red
- C. (1) **Enclosure 1**, Minimum Required Equipment, Phase I, Large Decay Heat Load and RCS Temp Less Than 200 Degrees with RCS Loops Filled
(2) Red
- D. (1) **Enclosure 2**, Minimum Required Equipment, Phase I, Large Decay Heat Load and RCS Temp Less Than 200 Degrees without RCS Loops Available
(2) Orange

**Turkey Point Nuclear Plant 2011
Senior Reactor Operator License Examination**

79.

Unit 3 is in MODE 1.

Which ONE of the following completes the statements below?

A failure of a 3A 4KV Bus Loss of Voltage Relay (ESFAS) is indicated by ____ (1) ____.

NOTE: For the next statement assume NO surveillance testing and no relay actuation occurred

In accordance with Technical Specifications, if TWO 4KV Bus Loss of Voltage Relays are inoperable, then ____ (2) ____.

REFERENCE PROVIDED

- A. (1) an amber light (PL-11) at Sequencer Panel 3C23A is OFF
(2) within 6 hours, place the failed relay in the tripped condition

- B. (1) Annunciator X2/1, 4KV BUS 3A LO VOLTAGE, is LIT
(2) within 6 hours, place the failed relay in the tripped condition

- C. (1) an amber light (PL-11) at Sequencer Panel 3C23A is OFF
(2) within 1 hour, initiate action to place the unit in at least HOT STANDBY within the next 6 hours

- D. (1) Annunciator X2/1, 4KV BUS 3A LO VOLTAGE, is LIT
(2) within 1 hour, initiate action to place the unit in at least HOT STANDBY within the next 6 hours

**Turkey Point Nuclear Plant 2011
Senior Reactor Operator License Examination**

80.

Given the following:

- Unit 4 experienced a Steam Generator Tube Rupture (SGTR) from 100% power.
- Containment temperature on TE-4-6700, TE-4-6701, and TE-4-6702 is 135°F and rising.
- The operating crew is implementing 4-EOP-E-3, Steam Generator Tube Rupture.
- The crew stopped the RCS cooldown and verified the ruptured S/G pressure is increasing slowly.
- QSPDS CET Subcooling is 70°F.
- Instrument Air to Containment has been lost, and CANNOT be established.

Which ONE of the choices below completes the following statements?

In order to remain in 4-EOP-E-3, Steam Generator Tube Rupture, RCS subcooling is required to be greater than ____ (1) ____.

If below the required RCS Subcooling for 4-EOP-E-3, then transition to ____ (2) ____.

- A. (1) 50°F
(2) 4-EOP-ECA-3.1, SGTR with Loss of Reactor Coolant, Subcooled Recovery Desired
- B. (1) 100°F
(2) 4-EOP-ECA-3.1, SGTR with Loss of Reactor Coolant, Subcooled Recovery Desired
- C. (1) 50°F
(2) 4-EOP-ECA-3.3, SGTR without Pressurizer Pressure Control
- D. (1) 100°F
(2) 4-EOP-ECA-3.3, SGTR without Pressurizer Pressure Control

**Turkey Point Nuclear Plant 2011
Senior Reactor Operator License Examination**

81.

The following conditions exist:

3-EOP-ECA-1.2, LOCA Outside Containment is in progress. MOV-3-744A/B, RHR Discharge to Cold Leg Isolation Valves, have been closed.

- RCS pressure indicates 1440 psig and rising.
- RCS temperature is 525°F and stable.
- Pressurizer level is 20% and rising.
- All ECCS equipment is running as required.
- RWST Level is 290,000 gallons and slowly lowering.
- AFW flow is 350 GPM.

Which ONE of the following identifies the required procedure sequence for the above plant conditions?

- A. 3-EOP-ECA-1.1, Loss of Emergency Coolant Recirculation → 3-EOP-E-1, Loss of Reactor or Secondary Coolant → 3-EOP-ES-1.1, SI Termination
- B. 3-EOP-E-1, Loss of Reactor or Secondary Coolant → 3-EOP-ES-1.1, SI Termination
- C. 3-EOP-ECA-1.1, Loss of Emergency Coolant Recirculation → 3-EOP-E-1, Loss of Reactor or Secondary Coolant → 3-EOP-ES-1.2, Post-LOCA Cooldown and Depressurization
- D. 3-EOP-E-1, Loss of Reactor or Secondary Coolant → 3-EOP-ES-1.2, Post-LOCA Cooldown and Depressurization

**Turkey Point Nuclear Plant 2011
Senior Reactor Operator License Examination**

82.

Unit 3 is raising power from 50% to 100% power at 10%/hr by boron dilution and rod withdrawal with the following initial conditions:

- Reactor Power 85%.
- Control Bank D Rods 200 steps with Rod Control in Manual.
- 30 minutes ago, a 200 gallon dilution to the RCS was performed over 3 minutes.

Subsequently,

- The RO momentarily placed the In/Out/Hold Switch to OUT.
- TAVG/TAVG – TREF DEVIATION (B 4/4) annunciator began alarming.
- Reactor power is currently 87% and rising slowly.
- VCT level has remained stable at 32% for the last 15 minutes.

Which ONE of the following identifies (1) the event in progress, and (2) the bases for the RPS trip designed for this event in accordance with the UFSAR?

- A. (1) Uncontrolled Rod Withdrawal
(2) Minimizes the impact on hot channel factors, $F_Q(Z)$ and $F_{\Delta h}^N$
- B. (1) Uncontrolled Rod Withdrawal
(2) Prevents Axial Flux Difference (AFD) from exceeding TS limits
- C. (1) Unplanned Dilution Event
(2) Minimizes the impact on hot channel factors, $F_Q(Z)$ and $F_{\Delta h}^N$
- D. (1) Unplanned Dilution Event
(2) Prevents Axial Flux Difference (AFD) from exceeding TS limits

**Turkey Point Nuclear Plant 2011
Senior Reactor Operator License Examination**

83.

Given the following:

Unit 3 has experienced a Large Break Loss of Coolant Accident (LOCA) from 100% power.

The operating crew notes the following parameters:

- Containment pressure is 38 psig.
- Containment temperature is 220°F.
- 4A HHSI Pump is running.
- 3A Containment Spray Pump is running.
- All other ECCS equipment is TRIPPED and CANNOT be started.
- All 3 Emergency Containment Coolers are TRIPPED.
- QSPDS CET Subcooling is (-) 38°F.
- CHRRMs are reading 1.3E5 R/hr.
- RAD-6304, Plant Vent SPING, reads 5.0E-1 µC/cc for 20 minutes.
- Dose assessments based on field measurements indicate dose at the Site Area Boundary is 150 mRem TEDE.
- Wind Speed is 6 mph.
- Wind Direction is 236°

Which ONE of the following below completes the table for the MINIMUM Protective Action Recommendations (PARs) for the above conditions?

REFERENCES PROVIDED

A.

<u>Miles</u>	<u>Evacuate Sectors</u>	<u>Shelter Sectors</u>	<u>No Action Sectors</u>
0-2	ALL	None	None
2-5	BCDE	All Remaining	None
5-10	None	ALL	None

B.

<u>Miles</u>	<u>Evacuate Sectors</u>	<u>Shelter Sectors</u>	<u>No Action Sectors</u>
0-2	ALL	None	None
2-5	BCD	All Remaining	None
5-10	None	ALL	None

C.

<u>Miles</u>	<u>Evacuate Sectors</u>	<u>Shelter Sectors</u>	<u>No Action Sectors</u>
0-2	None	All	None
2-5	None	BCDE	All Remaining
5-10	None	None	ALL

D.

<u>Miles</u>	<u>Evacuate Sectors</u>	<u>Shelter Sectors</u>	<u>No Action Sectors</u>
0-2	None	All	None
2-5	None	BCD	All Remaining
5-10	None	None	ALL

**Turkey Point Nuclear Plant 2011
Senior Reactor Operator License Examination**

84.

Given the following plant conditions:

- Unit 3 at 100% power.
- R-3-20, Reactor Coolant Letdown Monitor is in High Alarm.
- Chemistry reported Dose Equivalent I-131 has exceeded 100 $\mu\text{Ci/gm}$.
- A Unit 3 shutdown is in progress.

Which ONE of the choices below completes the following statements?

In accordance with 3-ONOP-041.4, Excessive Reactor Coolant System Activity, the average Reactor Coolant System temperature is required to be less than ____ (1) ____ within 6 hours.

IF the reactor coolant activity (dose equivalent iodine) stabilizes at 320 $\mu\text{Ci/gm}$ during the shutdown, THEN the highest required emergency classification is a/an ____ (2) ____.

REFERENCE PROVIDED

- A. (1) 350°F
(2) Alert
- B. (1) 500°F
(2) Alert
- C. (1) 350°F
(2) Notification Of Unusual Event
- D. (1) 500°F
(2) Notification Of Unusual Event

**Turkey Point Nuclear Plant 2011
Senior Reactor Operator License Examination**

85.

Following a LOCA, the crew entered 3-EOP-E-1, Loss of Reactor or Secondary Coolant.

The following plant conditions exist:

- Over the past 60 minutes, Tcold has dropped 210°F and is currently 330°F and stable.
- RCS pressure is 560 psig and stable.
- S/G pressures are 580 psig and lowering slowly.
- S/G Narrow Range levels are 40% - 45%.
- AFW flow is 300 GPM.
- Pressurizer Level is 10% and rising slowly.
- Containment temperature is 195°F.
- RWST level is 195,000 gallons and lowering.
- HHSI Flow is 750 gpm.
- RHR Flow is 0 gpm.

Based on the above conditions, which ONE of the following is the required procedure at this time?

- A. 3-EOP-ES-1.1, SI Termination
- B. 3-EOP-ES-1.2, Post LOCA Cooldown and Depressurization
- C. 3-EOP-ES-1.3, Transfer To Cold Leg Recirculation
- D. 3-EOP-FR-P.1, Response to Imminent Pressurized Thermal Shock Condition

**Turkey Point Nuclear Plant 2011
Senior Reactor Operator License Examination**

86.

The following conditions exist:

- Unit 4 is operating at 100% power.
- RCP A/B/C PUMP/MOTOR HI TEMP (H 9/6) is lit.
- RCP A MOTOR BEARING HI TEMP (H 9/1) is lit.
- 4A RCP Motor Bearing temperature is 187°F and rising at 5°F/minute.
- 4A RCP Motor Stator temperature is 223°F and rising at 5°F/minute.

Which ONE of the following completes the statements below?

The parameter that will first reach its RCP Trip Criteria value listed in 4-ONOP-041.1, Reactor Coolant Pump Off-Normal, is ____ (1) ____.

After the reactor is manually tripped, the NRC Operations Center is required to be notified within ____ (2) ____, in accordance with 0-ADM-115, Notification of Plant Events.

- A. (1) Motor Bearing temperature
(2) 1 hour
- B. (1) Motor Stator temperature
(2) 1 hour
- C. (1) Motor Stator temperature
(2) 4 hours
- D. (1) Motor Bearing temperature
(2) 4 hours

**Turkey Point Nuclear Plant 2011
Senior Reactor Operator License Examination**

87.

Unit 3 was operating at 100% power with the following conditions:

<u>Time</u>	<u>Log Entry</u>
-------------	------------------

1300	3-OSP-050.2, Residual Heat Removal System Inservice Test has been started for 3A RHR Pump.
1330	3A RHR Pump was declared INOPERABLE due to a problem occurring during 3-OSP-050.2.
1357	3B RHR Pump was declared INOPERABLE due to an excessive pump seal leakage.
1444	Unit 3 shutdown was commenced.
1551	3B RHR Pump was returned to OPERABLE status after pump seal repair.
1604	3A RHR Pump was returned to OPERABLE status.

Which ONE of the following describes the Technical Specification requirements for operation of the plant?

REFERENCE PROVIDED

- A. The Unit 3 Shutdown may be stopped, but no earlier than 1551.
- B. The Unit 3 Shutdown may be stopped, but no earlier than 1604.
- C. Unit 3 must be in MODE 3 by 1957, MODE 4 by 0157, and MODE 5 within the subsequent 24 hours.
- D. Unit 3 must be in MODE 3 by 2044, MODE 4 by 0244, and MODE 5 within the subsequent 24 hours.

**Turkey Point Nuclear Plant 2011
Senior Reactor Operator License Examination**

88.

The following conditions exist:

- Unit 3 and 4 are at 100% power.
- Unit 3 Startup Transformer is INOPERABLE.
- Estimated time for restoration is unknown.

Which ONE of the following identifies (1) the required Technical Specification action in accordance with Technical Specification 3.8.1, AC Sources, and (2) the bases for this action in accordance with O-ADM-536, Technical Specifications Bases Control Program?

REFERENCE PROVIDED

- A. (1) Reduce power operation to $\leq 30\%$ on Unit 3 within 48 hours, OR place the associated unit in at least HOT STANDBY within the next 12 hours.
(2) Allows for a reasonable restoration of the Startup Transformer, bounded by online risk assessment models.
- B. (1) Reduce power operation to $\leq 30\%$ on Unit 3 within 24 hours, then power operation for Unit 3 may continue for 30 days.
(2) Allows for a reasonable restoration of the Startup Transformer, bounded by online risk assessment models.
- C. (1) Reduce power operation to $\leq 30\%$ on Unit 3 within 48 hours, OR place the associated unit in at least HOT STANDBY within the next 12 hours.
(2) $< 30\%$ power operation reduces the decay heat level and allows for automatic Feedwater Control.
- D. (1) Reduce power operation $\leq 30\%$ on Unit 3 within 24 hours, then power operation for Unit 3 may continue for 30 days.
(2) $< 30\%$ power operation reduces the decay heat level and allows for automatic Feedwater Control.

**Turkey Point Nuclear Plant 2011
Senior Reactor Operator License Examination**

89.

The following conditions exist:

- A Waste Gas Decay Tank (WGT) E release was in progress.
- R-14, Plant Vent Gaseous Monitor, FAIL indicator light illuminates with indication pegged low.
- Initial sample results for release of the tank were acceptable in accordance with 0-NCOP-004, Preparation of Gas Release Permits.

Which ONE of the following identifies (1) if RCV-14 will automatically close and (2) in accordance with the Offsite Dose Calculation Manual (ODCM), the MINIMUM required actions to recommence the release with this failure?

- A. (1) Release will automatically terminate.
(2) The WGT E release may be recommenced ONLY after Chemistry performs ONE additional sample and ONE additional calculation.
- B. (1) Release will automatically terminate.
(2) The WGT E release may be recommenced ONLY after Chemistry performs TWO independent samples and TWO independent calculations.
- C. (1) Release will NOT automatically terminate.
(2) After the release has been locally terminated, the WGT E release may be recommenced ONLY after Chemistry performs ONE additional sample and ONE additional calculation.
- D. (1) Release will NOT automatically terminate.
(2) After the release has been locally terminated, the WGT E release may be recommenced ONLY after Chemistry performs TWO independent samples and TWO independent calculations.

**Turkey Point Nuclear Plant 2011
Senior Reactor Operator License Examination**

90.

The following conditions exist:

- Unit 3 is at 100%.
- Traveling Screen D/P is 8.0" H₂O.
- ICW/CCW and ICW/TPCW Basket Strainers are clogging due to grass influx.
- 3C ICW Pump out of service.
- 3A, 3B, and 3C CCW Heat Exchangers have ICW flows at 3000 gpm each.
- CCW Heat Exchanger Outlet temperature (shell side) is 104°F and stable.

Which ONE of the following identifies the MINIMUM required ACTIONS of TS 3.7.3, Intake Cooling Water System?

REFERENCE PROVIDED

- A. TS 3.7.3 ACTION A ONLY
- B. TS 3.7.3 ACTION C ONLY
- C. TS 3.7.3 ACTIONS A and C ONLY
- D. TS LCO 3.0.3 and TS 3.7.3 ACTIONS A and C

**Turkey Point Nuclear Plant 2011
Senior Reactor Operator License Examination**

91.

The following conditions exist:

- Unit 3 is operating at 100% power.
- Annunciator F-4/6, RPIS POWER TROUBLE is lit.
- Unit 3 Turbine Operator reports the RPI Inverter Output Breaker, 3Y03-CB6, is open.

Which ONE of the following (1) identifies which Control Rod Position Analog/Group Demand Position indication that is lost, and (2) determines the required Technical Specification ACTION?

- A. (1) Analog Rod Position Indications
(2) Determine the position of the non-indicating rod(s) indirectly by the movable incore detectors at least once per 8 hours.
- B. (1) Group Step Counter Demanded Position Indicators
(2) Verify that all analog rod position indicators for the affected bank are OPERABLE and that the most withdrawn rod and the least withdrawn rod of the bank are within the Allowed Rod Misalignment of Specification 3.1.3.1 at least once per 8 hours.
- C. (1) Analog Rod Position Indications
(2) Reenergize the RPIS Loads within 1 hour OR be in at least HOT STANDBY in next 6 hours
- D. (1) Group Step Counter Demanded Position Indicators
(2) Reenergize the RPIS Loads within 1 hour OR be in at least HOT STANDBY in next 6 hours

**Turkey Point Nuclear Plant 2011
Senior Reactor Operator License Examination**

92.

Given the following conditions:

- A Liquid Release is in progress from Recycle Monitor Tank A to Discharge Canal using Monitor Tank Pump A.
- Annunciator WASTE LIQUID HI RADIATION (WB.B 5/3) is received.
- RCV-018, Liquid Waste Discharge Isolation Valve, fails to close either automatically or manually.
- The Shift Manager has determined an Unmonitored Release has occurred.

Which ONE of the following identifies (1) the NEXT action required in accordance with 0-NOP-061.11A, Controlled Liquid Release from Recycle Monitor Tank A, and (2) the MINIMUM required NRC notification(s) in accordance with 0-ADM-115, Notification of Plant Events?

- A. (1) Stop the Monitor Tank Pump A
(2) Notify the NRC Resident ONLY
- B. (1) Stop the Monitor Tank Pump A
(2) Notify the NRC Resident and the NRC Operations Center
- C. (1) Close 1282, Monitor Tank A Outlet Valve
(2) Notify the NRC Resident ONLY
- D. (1) Close 1282, Monitor Tank A Outlet Valve
(2) Notify the NRC Resident and the NRC Operations Center

**Turkey Point Nuclear Plant 2011
Senior Reactor Operator License Examination**

93.

Unit 3 is in MODE 3 during a reactor startup.

- Core Exit Thermocouples from B QSPDS Train are out of service.
- The Train A QSPDS readings are provided on the DCS printout from QSPDS CET/HJTC Channel A display.

Which ONE of the following describes (1) the ACTION(s) required for Core Exit TCs in accordance with TS 3.3.3.3, Accident Monitoring Instrumentation, and (2) the impact to the reactor startup?

REFERENCES PROVIDED

- A. (1) Action Statement 31.
(2) The startup may NOT continue.
- B. (1) Action Statement 32.
(2) The startup may NOT continue.
- C. (1) Action Statement 32.
(2) The startup may continue.
- D. (1) Action Statement 31
(2) The startup may continue.

**Turkey Point Nuclear Plant 2011
Senior Reactor Operator License Examination**

94.

Given the following:

<u>Date</u>	<u>Time</u>	<u>Activity</u>
12/31/2011	0000	A Unit 4 Shutdown to MODE 3 is commenced.
12/31/2011	0630	Unit 4 enters MODE 3.
12/31/2011	1320	Unit 4 enters MODE 4.
12/31/2011	2210	Unit 4 enters MODE 5.
01/01/2012	2200	The first Reactor Vessel Head Stud is detensioned.
01/03/2012	0100	The Reactor Vessel Head is removed.

Which ONE of the following is (1) the EARLIEST time to commence fuel movement in accordance with Technical Specifications, and (2) the basis for the time requirement?

- A. (1) 01/03/12 at 0630
(2) Ensures the heat load assumptions specified in the safety analysis are met to prevent boiling in the Spent Fuel Pool.
- B. (1) 01/03/12 at 0630
(2) Ensures that the release of fission product radioactivity, subsequent to a fuel handling accident, results in doses that are well within the values specified in the safety analysis.
- C. (1) 01/04/12 at 2200
(2) Ensures the heat load assumptions specified in the safety analysis are met to prevent boiling in the Spent Fuel Pool.
- D. (1) 01/04/12 at 2200
(2) Ensures that the release of fission product radioactivity, subsequent to a fuel handling accident, results in doses that are well within the values specified in the safety analysis.

**Turkey Point Nuclear Plant 2011
Senior Reactor Operator License Examination**

95.

A plant cooldown is in progress on Unit 3:

- RCS temperature is 260°F.
- RCS pressure is 350 psig.
- OMS was placed in service at 0900 at 275°F.
- At 1000, the crew discovered 3-OSP-041.4, Overpressure Mitigating System Nitrogen Backup Leak and Functional Test, was NOT completed for both PORVs.

Which ONE of the following describes the current MODE and the LASTEST time the OMS Surveillance is required to be completed?

REFERENCE PROVIDED

	<u>Unit 3 Status</u>	<u>3-OSP-041.4 must be complete by</u>
A.	MODE 3	0900, tomorrow
B.	MODE 3	2100, today
C.	MODE 4	2100, today
D.	MODE 4	0900, tomorrow

**Turkey Point Nuclear Plant 2011
Senior Reactor Operator License Examination**

96.

0-OSP-040.16, Initial Criticality After Refueling and Nuclear Design Verification is being performed on Unit 3.

Which ONE of the following completes the statements below in accordance with 0-ADM-217, Conduct of Infrequently Performed Tests or Evolutions?

The Management Designee role (1) .

The Management Designee role (2) to be simultaneously filled by the Unit 3 - Unit Supervisor.

- A. (1) is ONLY allowed to be Shift Managers OR Unit Supervisors
(2) is allowed
- B. (1) is ONLY allowed to be Shift Managers OR Unit Supervisors
(2) is NOT allowed
- C. (1) can be any individual designated by the Plant General Manager
(2) is allowed
- D. (1) can be any individual designated by the Plant General Manager
(2) is NOT allowed

**Turkey Point Nuclear Plant 2011
Senior Reactor Operator License Examination**

97.

A Unit 3 Containment Purge is scheduled for this shift while in MODE 1.

Which ONE of the following identifies (1) the MINIMUM requirement for radiation monitor operability, and (2) the LOWEST required authorization to initiate a Containment Purge in accordance with 3-NOP-053, Containment Purge System?

Note:

R-3-11 (Particulate) and R-3-12 (Gaseous) Containment Radiation Monitors

R-3-14 (Plant Vent) and RAD-6304 (Plant Vent SPING) Radiation Monitors

- A. (1) R-3-11, R-3-12, R-3-14, and RAD-6304
(2) Plant General Manager
- B. (1) R-3-11 or R-3-12 and R-3-14 or RAD-6304
(2) Plant General Manager
- C. (1) R-3-11, R-3-12, R-3-14, and RAD-6304
(2) Shift Manager
- D. (1) R-3-11 or R-3-12 and R-3-14 or RAD-6304
(2) Shift Manager

**Turkey Point Nuclear Plant 2011
Senior Reactor Operator License Examination**

98.

Which ONE of the following completes both statements in accordance with 0-EPIP-20111, Re-entry?

The _____ is responsible for authorizing emergency exposures that exceed 10CFR20 limits.

The emergency exposure limit for performance of actions that mitigate the escalation of the event, rescue persons from a non-life threatening situation, minimize personnel exposure or minimize effluent releases is _____.

- A. (1) Emergency Coordinator (EC)
(2) 5 REM
- B. (1) OSC Rad Protection Supervisor
(2) 5 REM
- C. (1) Emergency Coordinator (EC)
(2) 10 REM
- D. (1) OSC Rad Protection Supervisor
(2) 10 REM

**Turkey Point Nuclear Plant 2011
Senior Reactor Operator License Examination**

99.

Unit 4 experienced a 4C Steam Generator Tube Rupture with the crew responding in accordance with 4-EOP-E-3, Steam Generator Tube Rupture.

Subsequently:

- All Unit 4 Aux Feedwater Steam Supply Valves to Aux Feedwater Pumps are open with the AFW Pumps supplying S/Gs 4A and 4B.
- 4C S/G Steam Dump to Atmosphere Valve stuck open and was manually isolated.
- The Unit 4 Turbine Operator has just been directed to reposition AFSS-3-006, STM HDR TRAIN 1 AND 2 TIE VALVE, and AFSS-3-007, S/G B TO STM HDR TRAIN 1 TIE VALVE, to provide steam from an intact S/G(s) to all AFW Pumps.
- No other actions in 4-EOP-E-3 have been taken.

Which ONE of the following identifies whether a release path currently exists and the highest required emergency classification?

A release path (1) .

The highest required emergency classification is (2) .

REFERENCE PROVIDED

- A. (1) does NOT exist
(2) Alert
- B. (1) does NOT exist
(2) Site Area Emergency
- C. (1) exists
(2) Alert
- D. (1) exists
(2) Site Area Emergency

**Turkey Point Nuclear Plant 2011
Senior Reactor Operator License Examination**

100.

Initial conditions:

At 1200, Unit 3 has declared a Site Area Emergency.

At 1215, the State Warning Point was notified.

At 1240, the NRC was notified.

At 1250, Unit 4 declares an Alert.

In accordance with 0-EPIP-20134, Offsite Notifications and Protective Action Recommendations, which ONE of the following blocks is required to be checked on the Florida State Notification Form and the latest time to notify the State Warning Point concerning Unit 4?

- A. Initial/New Classification Block
No later than 1305
- B. Initial/New Classification Block
No later than 1315
- C. Update Notification Block
No later than 1305
- D. Update Notification Block
No later than 1315

Reference for Question #2

Header pages are only for ease of NRC Exam review process. They will not be included with the student exam package. In addition, References will be randomly arranged so as not to inappropriately queue students during the exam.

- SRO Exam includes all references.
- RO Exam includes references for questions 1-75.

Picture of 3A S/G Steam Dump to
Atmosphere Controller CV-3-1606

3A STEAM GENERATOR
STEAM DUMP TO ATMOSPHERE
CV-3-1606

3P07

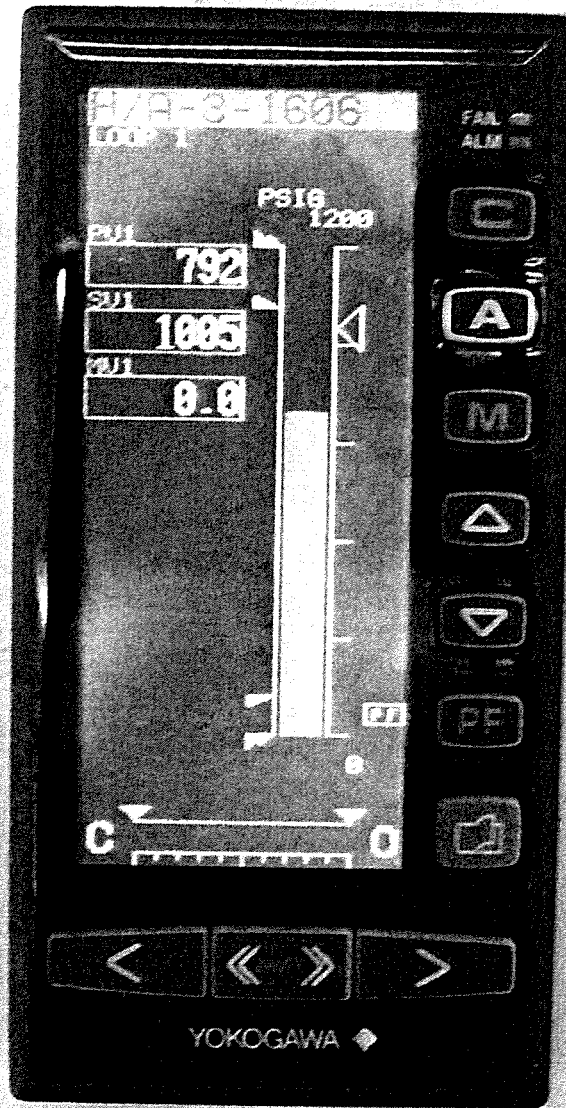

Reference for Question #21

TechSpec 3.1.1.1, page 3/4 1-3

*Figure 3.1-1 Required Shutdown Margin vs Reactor
Coolant Boron Concentration*

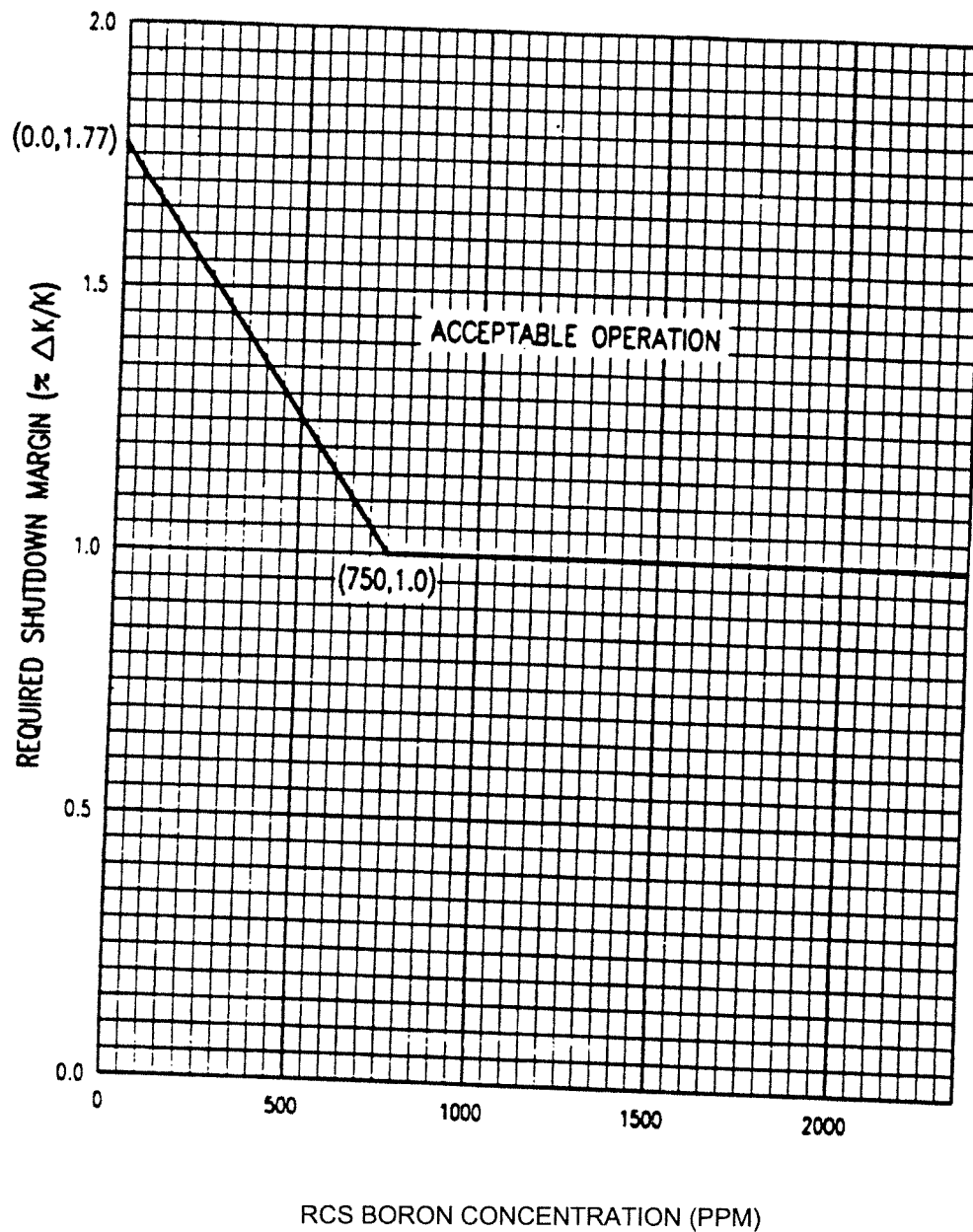

Figure 3.1-1
 Required Shutdown Margin vs Reactor Coolant
 Boron Concentration

Reference for Question #55

Drawing # 5614-E-25, Sheet 1A,
Reactor Auxiliaries Reactor Coolant Pump 4A
Breaker 4AAØ1

Drawing # 5614-E-25, Sheet 1A1
Reactor Auxiliaries Reactor Coolant Pump 4A
Breaker 4AAØ1

REV	DATE	ISSUED AS-BUILT FOR PC/M	REV	DATE	ISSUED AS-BUILT FOR PC/M
5	4/26/94	ISSUED AS-BUILT PER PC/M 03-012	4	1-15-94	ISSUED AS-BUILT FOR DCR-TRF-93-514
4	4/15/92	ISSUED AS-BUILT FOR DCR-TRF-92-058	3	11/14/91	ISSUED AS-BUILT FOR PC/M 87-257 & 87-254
2			2		

REV	DATE	INITIALS ON FILE	APP	REVISION
5		RV	APP	BY
4		RV	APP	CH
3		RV	APP	MA
2		RV	APP	MA

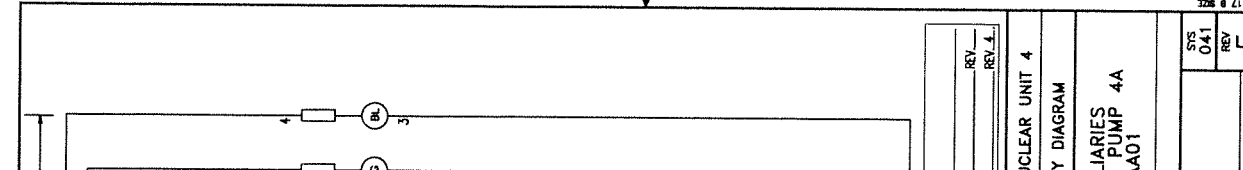
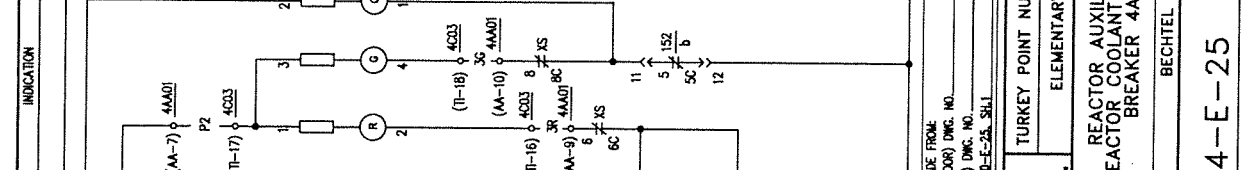
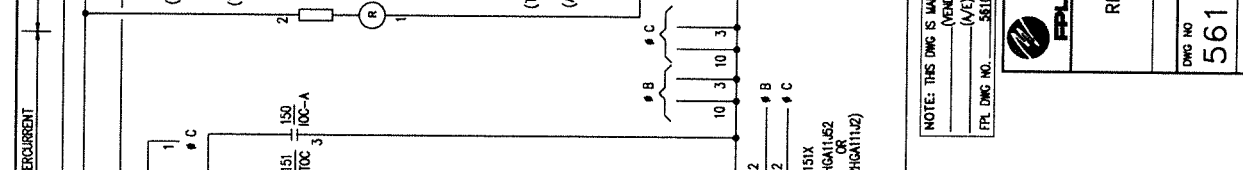
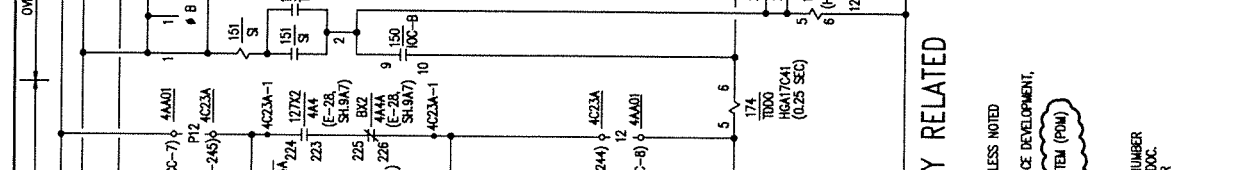
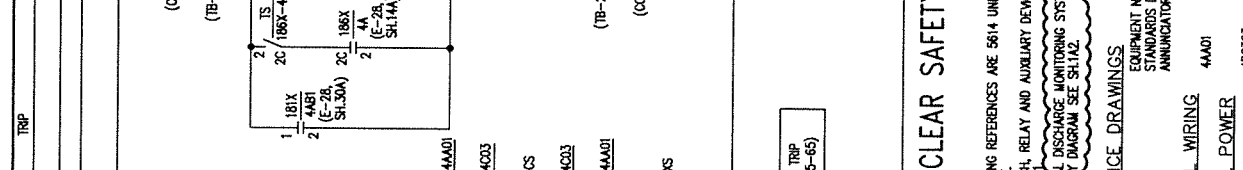
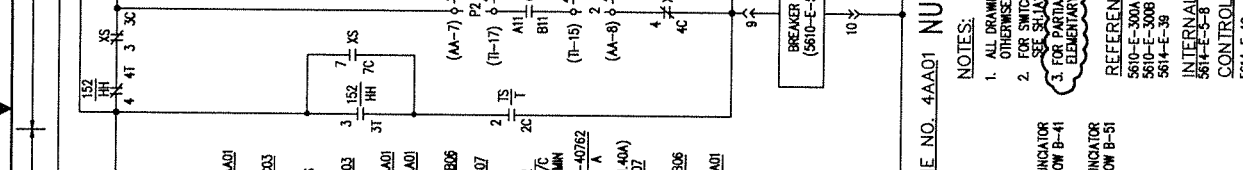
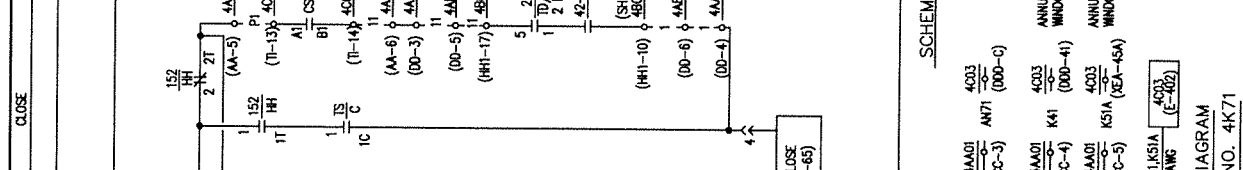
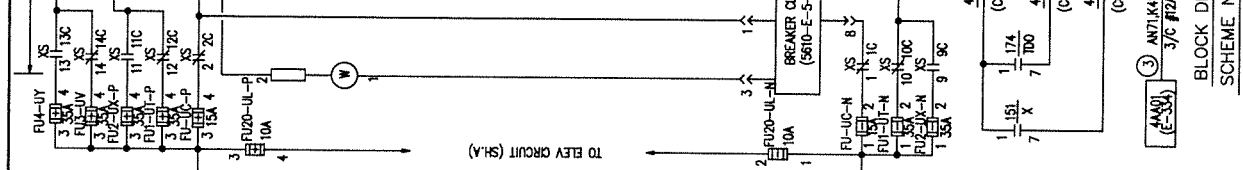
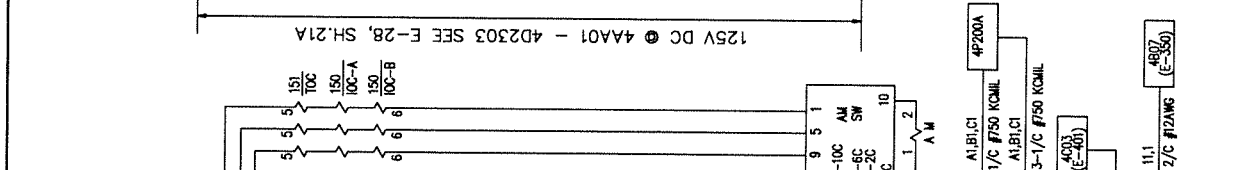
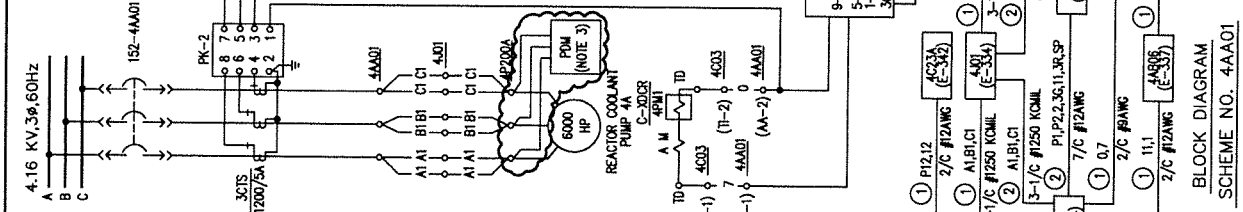

NOTE: THIS DWG IS MADE FROM (VENDOR) DWG. NO. (A/E) DWG. NO. REV. 4. FPL DWG NO. 5614-E-38, SH.1

TURKEY POINT NUCLEAR UNIT 4

ELEMENTARY DIAGRAM

REACTOR AUXILIARIES

REACTOR COOLANT PUMP 4A

BREAKER 4AA01

BECHTEL

DWG NO. **5614-E-25**

SHEET 1A

SVS 041

REV. **5**

FILE: UTE00448.DWG

SCHEME NO. 4AA01 NUCLEAR SAFETY RELATED

NOTES:

- ALL DRAWING REFERENCES ARE 5614 UNLESS NOTED OTHERWISE.
- FOR SWITCH, RELAY AND AUXILIARY DEVICE DEVELOPMENT, SEE SJA.
- FOR PARTIAL DISCHARGE MONITORING SYSTEM (PDM) ELEMENTARY DIAGRAM SEE SH.1A2.

REFERENCE DRAWINGS

5610-E-300A EQUIPMENT NUMBER

5614-E-3000 STANDARDS DOC.

5614-E-38 ANNUNCIATOR

INTERNAL WIRING

5614-E-3-8 4AA01

5614-E-12 402303

CONTROL POWER

5614-E-12 402303

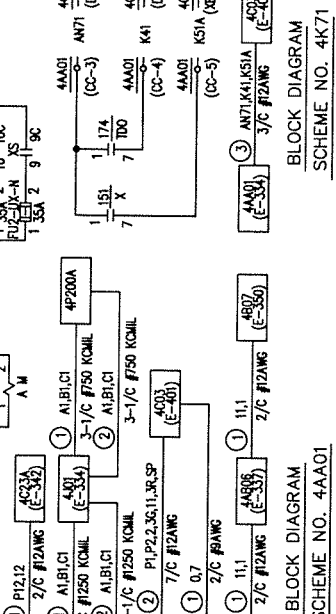

REV	DATE	ISSUED AS-BUILT FOR PC/M	REV	DATE	ISSUED AS-BUILT FOR PC/M
5	4/26/94	ISSUED AS-BUILT PER PC/M 03-012	4	1-15-94	ISSUED AS-BUILT FOR DCR-TRF-93-514
4	4/15/92	ISSUED AS-BUILT FOR DCR-TRF-92-058	3	11/14/91	ISSUED AS-BUILT FOR PC/M 87-257 & 87-254
2			2		

REV	DATE	INITIALS ON FILE	APP	REVISION
5		RV	APP	BY
4		RV	APP	CH
3		RV	APP	MA
2		RV	APP	MA

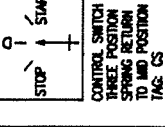

CONTACTS	POSITION		FUNCTION	DRAWING
	STOP	AFTER START		
A11-B11	X	X	TRIP CKT	E-25 SH1A
A12-B12	X	X	SPARE	E-25 SH1A
A1-B1	X	X	CLOSE CKT	E-25 SH1A
A5-A6	X	X	SPARE	
A6-A7	X	X	SPARE	
B5-B6	X	X	SPARE	
B6-B7	X	X	SPARE	
C11-D11	X	X	SPARE	
C2-D2	X	X	SPARE	
C1-D1	X	X	SPARE	
C5-C6	X	X	SPARE	
C6-C7	X	X	SPARE	
D5-D6	X	X	SPARE	
D6-D7	X	X	SPARE	

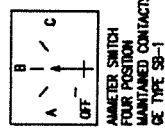

CONTACTS HANDLE END	POSITION												FUNCTION	DRAWING
	1	2	3	4	5	6	7	8	9	10	11	12		
1 1C-2C	X	X	X	X	X	X	X	X	X	X	X	X	AMMETER CIRCUIT	E-25 SH1A
2 1A-6 0-1-0	X	X	X	X	X	X	X	X	X	X	X	X	NOT USED	E-25 SH1A
3 3C	X	X	X	X	X	X	X	X	X	X	X	X	AMMETER CIRCUIT	E-25 SH1A
5 5C-6C	X	X	X	X	X	X	X	X	X	X	X	X	AMMETER CIRCUIT	E-25 SH1A
6 6A-6 0-4-0	X	X	X	X	X	X	X	X	X	X	X	X	AMMETER CIRCUIT	E-25 SH1A
7 7C	X	X	X	X	X	X	X	X	X	X	X	X	NOT USED	E-25 SH1A
9 9C-10C	X	X	X	X	X	X	X	X	X	X	X	X	AMMETER CIRCUIT	E-25 SH1A
10 10A-6 0-1-0	X	X	X	X	X	X	X	X	X	X	X	X	AMMETER CIRCUIT	E-25 SH1A
11 11C	X	X	X	X	X	X	X	X	X	X	X	X	NOT USED	E-25 SH1A
11 11-0	X	X	X	X	X	X	X	X	X	X	X	X	NOT USED	E-25 SH1A

X - DENOTES CONTACT CLOSED
* - DENOTES MAKE-BEFORE-BREAK

X - DENOTES CONTACT CLOSED

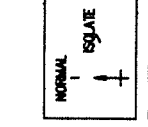

CONTACTS HANDLE END	ODD	EVEN	POSITION		FUNCTION	DRAWING
			ON	OFF		
1 1-1C	2C-2	1	X	X	CLOSE CKT	E-25 SH1A
2 3-3C	4C-4	3	X	X	CLOSE CKT	E-25 SH1A
3 5-5C	6C-6	4	X	X	TRIP CKT	E-25 SH1A
4 7-7C	8C-8	5	X	X	TRIP CKT	E-25 SH1A
5 9-9C	10C-10	6	X	X	INDICATION CKT	E-25 SH1A
6 11-11C	12C-12	7	X	X	TRIP CKT	E-25 SH1A
7 13-13C	14C-14	8	X	X	INDICATION CKT	E-25 SH1A
8 15-15C	16C-16	9	X	X	TRANSFER FUSES	E-25 SH1A
9 17-17C	18C-18	10	X	X	TRANSFER FUSES	E-25 SH1A
10 19-19C	20C-20	11	X	X	TRANSFER FUSES	E-25 SH1A
		12	X	X	TRANSFER FUSES	E-25 SH1A
		13	X	X	TRANSFER FUSES	E-25 SH1A
		14	X	X	TRANSFER FUSES	E-25 SH1A
		15	X	X	ANNUNCIATOR CKT	E-27 SH129B
		16	X	X	SPARE	
		17	X	X	SPARE	
		18	X	X	SPARE	
		19	X	X	SPARE	
		20	X	X	SPARE	

X - DENOTES CONTACT CLOSED

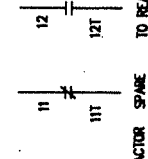
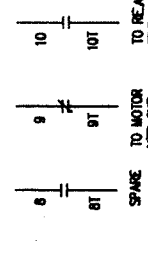
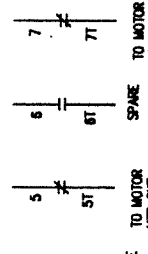
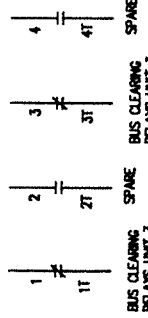

152M - BREAKER POSITION SWITCH

CONTACTS OPER. HANDLE END	ODD	EVEN	POSITION	FUNCTION	DRAWING
1T	2	1T	1	X	E-25 SH1A
2T	3	2T	2	X	E-25 SH1A
3T	4	3T	3	X	E-25 SH1A
4T	5	4T	4	X	E-25 SH1A
5T	6	5T	5	X	E-25 SH1A
6T	7	6T	6	X	E-25 SH1A

X - DENOTES CONTACT CLOSED

152 STA CONTACTS

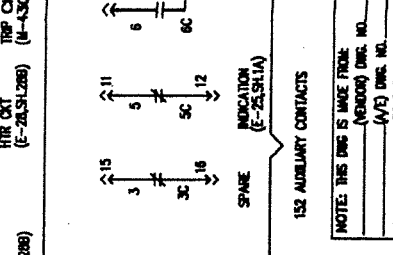

152 AUXILIARY CONTACTS

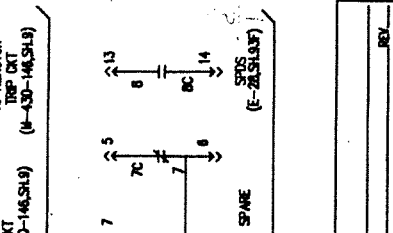

NOTE: THIS Dwg IS MADE FROM (REVISED) Dwg. NO. (A/F) Dwg. NO. FPL Dwg. NO. 5614-E-25 SH1A REV. 4

CONTACTS HANDLE END	ODD	EVEN	POSITION		FUNCTION	DRAWING
			TRIP	CLOSE		
1-1C	2C-2	1	X	X	CLOSE CKT	E-25 SH1A
		2	X	X	TRIP CKT	E-25 SH1A

X - DENOTES CONTACT CLOSED

CONT. POS.	DESCRIPTION	BREAKER	DRAWING
1-7	N.O.	ANNUNCIATION 44A01	E-25 SH1A
3-7	N.C.	NOT USED	
2-8	N.O.	SPARE	
4-8	N.C.	SPARE	

151X

174 1000(255C)

CONT. POS.	DESCRIPTION	BREAKER	DRAWING
1-7	N.O.	ANNUNCIATION 44A01	E-25 SH1A
3-7	N.C.	NOT USED	
2-8	N.O.	SPARE	

NUCLEAR SAFETY RELATED

PPPL
TURKEY POINT NUCLEAR UNIT 4
ELEMENTARY DIAGRAM
REACTOR AUXILIARIES
REACTOR COOLANT PUMP 4A
BREAKER 44A01
BECHTEL

DWG NO	5614-E-25
SHEET 1A1	2

REV 041

Reference for Question #79

Tech Spec 3.3.2, ESFAS Instrumentation,
pages 3/4 3-13, 3-19 (only Function 7),
3-20 (only Function 7), 3-21, 3-22.

INSTRUMENTATION

3/4.3.2 ENGINEERED SAFETY FEATURES ACTUATION SYSTEM INSTRUMENTATION

LIMITING CONDITION FOR OPERATION

3.3.2 The Engineered Safety Feature Actuation System (ESFAS) instrumentation channels and interlocks shown in Table 3.3-2 shall be OPERABLE with their Trip Setpoints set consistent with the values shown in the Trip Setpoint column of Table 3.3-3.

APPLICABILITY: As shown in Table 3.3-2.

ACTION:

- a. With an ESFAS Instrumentation or Interlock Trip Setpoint less conservative than the value shown in the Trip Setpoint column but more conservative than the value shown in the Allowable Value column of Table 3.3-3, adjust the Setpoint consistent with the Trip Setpoint value within permissible calibration tolerance.
- b. With an ESFAS Instrumentation or Interlock Trip Setpoint less conservative than the value shown in the Allowable Value column of Table 3.3-3, either:
 1. Adjust the Setpoint consistent with the Trip Setpoint value of Table 3.3-3 and determine within 12 hours that the affected channel is OPERABLE; or
 2. Declare the channel inoperable and apply the applicable ACTION statement requirements of Table 3.3-2 until the channel is restored to OPERABLE status with its setpoint adjusted consistent with the Trip Setpoint value.
- c. With an ESFAS instrumentation channel or interlock inoperable, take the ACTION shown in Table 3.3-2.

SURVEILLANCE REQUIREMENTS

4.3.2.1 Each ESFAS instrumentation channel and interlock and the automatic actuation logic and relays shall be demonstrated OPERABLE by performance of the ESFAS Instrumentation Surveillance Requirements specified in Table 4.3-2.

TABLE 3.3-2 (Continued)
ENGINEERED SAFETY FEATURES ACTUATION SYSTEM INSTRUMENTATION

<u>FUNCTIONAL UNIT</u>	<u>TOTAL NO. OF CHANNELS</u>	<u>CHANNELS TO TRIP</u>	<u>MINIMUM CHANNELS OPERABLE</u>	<u>APPLICABLE MODES</u>	<u>ACTION</u>
6.	[REDACTED]				
7. Loss of Power					
a. 4.16 kV Busses A and B (Loss of Voltage)	2/bus	2/bus	2/bus	1, 2, 3, 4	18
b. 480 V Load Centers 3A, 3B, 3C, 3D and 4A, 4B, 4C, 4D Undervoltage	2 per load center	2 on any load center	2 per load center	1, 2, 3, 4	18
Coincident with: Safety Injection					See Item 1. above for all Safety Injection initiating functions and requirements.

TABLE 3.3-2 (Continued)
ENGINEERED SAFETY FEATURES ACTUATION SYSTEM INSTRUMENTATION

<u>FUNCTIONAL UNIT</u>	<u>TOTAL NO. CHANNELS OF CHANNELS</u>	<u>CHANNELS TO TRIP</u>	<u>MINIMUM CHANNELS OPERABLE</u>	<u>APPLICABLE MODES</u>	<u>ACTION</u>
7. Loss of Power (Continued)					
c. 480 V Load Centers	2 per load center	2 on any load center	2 per load center	1, 2, 3, 4	18
3A, 3B, 3C, 3D and					
4A, 4B, 4C, 4D					
Degraded Voltage					

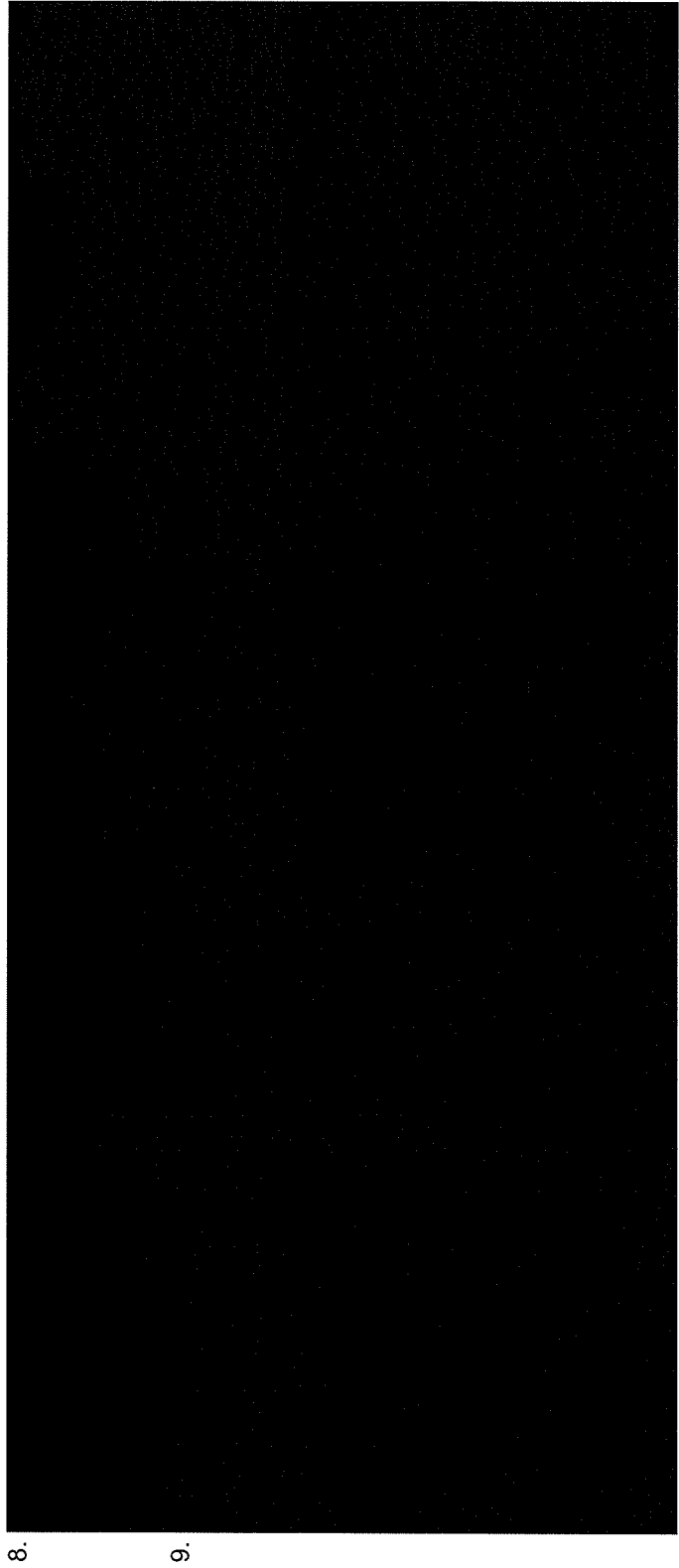

TABLE 3.3-2 (Continued)

TABLE NOTATION

- # Trip function may be blocked in this MODE below the Pressurizer Pressure Interlock Setpoint of 2000 psig.
- ## Channels are for particulate radioactivity and for gaseous radioactivity.
- ### Auxiliary feedwater manual initiation is included in Specification 3.7.1.2.
- #### Steam Generator overflow protection is not part of the Engineered Safety Features Actuation System (ESFAS), and is added to the Technical Specifications only in accordance with NRC Generic Letter 89-19.
- * Trip function may be blocked in this MODE below the T_{avg} --Low Interlock Setpoint.
- ** Only during CORE ALTERATIONS or movement of irradiated fuel within the containment.

ACTION STATEMENTS

- ACTION 14 - With the number of OPERABLE channels one less than the Minimum Channels OPERABLE requirement, be in at least HOT STANDBY within 12 hours and in COLD SHUTDOWN within the following 30 hours; however, one channel may be bypassed for up to 8 hours for surveillance testing per Specification 4.3.2.1, provided the other channel is OPERABLE.
- ACTION 15 - With the number of OPERABLE channels one less than the Total Number of Channels, operation may proceed until performance of the next required ANALOG CHANNEL OPERATIONAL TEST or TRIP ACTUATING DEVICE OPERATIONAL TEST provided the inoperable channel is placed in the tripped condition within 6 hours.
- ACTION 16 - With less than the Minimum Channels OPERABLE requirement, comply with the ACTION statement requirements of Specification 3.3.3.1 Item 1a of Table 3.3-4.
- ACTION 17 - With the number of OPERABLE channels one less than the Minimum Channels OPERABLE requirement, restore the inoperable channel to OPERABLE status within 48 hours or be in at least HOT STANDBY within the next 6 hours and in COLD SHUTDOWN within the following 30 hours.

TABLE 3.3-2 (Continued)

TABLE NOTATION (Continued)

- ACTION 18 - With the number of OPERABLE channels one less than the Total Number of Channels, STARTUP and/or POWER OPERATION may proceed provided the inoperable channel is placed in the tripped condition within 6 hours. Both channels of any one load center may be taken out of service for up to 8 hours in order to perform surveillance testing per Specification 4.3.2.1.
- ACTION 19 - With less than the Minimum Number of Channels OPERABLE, within 1 hour determine by observation of the associated permissive annunciator window(s) that the interlock is in its required state for the existing plant condition, or apply Specification 3.0.3.
- ACTION 20 - With the number of OPERABLE channels one less than the Minimum Channels OPERABLE requirement, be in at least HOT STANDBY within 6 hours and in at least HOT SHUTDOWN within the following 6 hours; however, one channel may be bypassed for up to 8 hours for surveillance testing per Specification 4.3.2.1 provided the other channel is OPERABLE.
- ACTION 21 - With the number of OPERABLE channels one less than the Total Number of Channels, restore the inoperable channel to OPERABLE status within 48 hours or declare the associated valve inoperable and take the ACTION required by Specification 3.7.1.5.
- ACTION 22 - With the number of OPERABLE channels one less than the Minimum Channels OPERABLE requirement, be in at least HOT STANDBY within 6 hours; however, one channel may be bypassed for up to 8 hours for surveillance testing per Specification 4.3.2.1 provided the other channel is OPERABLE.
- ACTION 23 - With the number of OPERABLE channels one less than the Minimum Channels OPERABLE requirement, comply with Specification 3.0.3.
- ACTION 24 - With the number of OPERABLE channels one less than the Minimum Channels OPERABLE requirement, within 1 hour isolate the control room Emergency Ventilation System and initiate operation of the Control Room Emergency Ventilation System in the recirculation mode.
- ACTION 25 - With number of OPERABLE channels one less than the Total number of channels, STARTUP and/or POWER OPERATION may proceed provided the inoperable channel is placed in the tripped condition within 6 hours. For subsequent required DIGITAL CHANNEL OPERATIONAL TESTS the inoperable channel may be placed in bypass status for up to 4 hours.

Reference for Question #83

Form F-439, Florida Nuclear Plant Emergency
Notification Form (Front and Back)

Form F-444, Guidance For Determining Protective
Action Recommendations (PARs), page 1, 2, 3, 4, 5

FLORIDA NUCLEAR PLANT EMERGENCY NOTIFICATION FORM

Online Verification: STATE MIAMI-DADE COUNTY MONROE COUNTY

- *1. A. This Is A Drill B. This Is An Actual Event
2. A. Date ____/____/____ *B. Contact Time: _____ C. Reported by: Name _____
D. Message Number: _____ E. Reported From: Control Room TSC EOF
F. Initial/New Classification OR Update Notification
*3. SITE A. Crystal River UNIT 3 B. St. Lucie UNIT 4 C. St. Lucie UNIT 2
D. Turkey Point UNIT 3 E. Turkey Point UNIT 4

- *4. EMERGENCY CLASSIFICATION: A. Notification Of Unusual Event B. Alert
C. Site Area Emergency D. General Emergency

*5. A. EMERGENCY DECLARATION: B. EMERGENCY TERMINATION Date: ____/____/____ Time: _____

*6. REASON FOR EMERGENCY DECLARATION:** A. EAL Number: _____ OR B. Description _____

7. ADDITIONAL INFORMATION OR UPDATE: A. None OR B. Description _____

*8. WEATHER DATA: A. Wind direction from _____ degrees. B. Downwind Sectors Affected _____

*9. RELEASE STATUS: A. None (Go to Item 11) B. In Progress C. Has occurred, but stopped (go to Item 11)

10. RELEASE SIGNIFICANCE CATEGORY (at the Site Boundary)

- A. Under evaluation B. Release within Normal Operating Limits (Tech Specs)
C. Non-Significant (Fraction of PAG Range) D. PAG Range (Protective Actions required)
E. Liquid release (no actions required)

*11. UTILITY RECOMMENDED PROTECTIVE ACTIONS FOR THE PUBLIC:

A. No recommended actions at this time. B. The utility recommends the following protective actions:

<u>EVACUATE ZONES:</u> NOT APPLICABLE	<u>OR</u>	<u>Miles</u>	<u>Evacuate Sectors</u>	<u>Shelter Sectors</u>	<u>No Action Sectors</u>
<u>SHELTER ZONES:</u> NOT APPLICABLE		0 - 2	_____	_____	_____
		2 - 5	_____	_____	_____
		5 - 10	_____	_____	_____

AND consider issuance of potassium iodide (KI)

If form is completed in the Control Room, go to item 15. If completed in the TSC or EOF, continue with item 12.

12. PLANT CONDITIONS:

- A. Reactor Shutdown? YES NO B. Core Adequately Cooled? YES NO
C. Containment Intact? YES NO D. Core Condition: Stable Degrading

13. WEATHER DATA: A. Wind Speed _____ mph B. Stability Class _____

14. ADDITIONAL RELEASE INFORMATION: A. Not applicable (Go to Item 15)

<u>Distance</u>	<u>Projected Thyroid Dose (CDE) for 1 Hour</u>	<u>Projected Total Dose (TEDE) for 1 Hour</u>
1 Mile (Site Boundary)	B. _____ mrem	C. _____ mrem
2 Miles	D. _____ mrem	E. _____ mrem
5 Miles	F. _____ mrem	G. _____ mrem
10 Miles	H. _____ mrem	I. _____ mrem

15. (Do not read to State) EC or RM Approval Signature _____ Date ____/____/____ Time _____

MESSAGE RECEIVED BY: Name _____ Date ____/____/____ Time _____

** IF EMERGENCY CLASS ESCALATION IS KNOWN TO BE NECESSARY AND A NEW NOTIFICATION FORM WILL BE TRANSMITTED WITHIN 15 MINUTES, THEN YOU MAY GO TO EC/RM APPROVAL SIGNATURE LINE.

* ITEMS ARE EVALUATED FOR NRC PERFORMANCE INDICATORS (PIs)

FLORIDA NUCLEAR PLANT EMERGENCY NOTIFICATION FORM

METEOROLOGICAL WORKSHEET

SECTOR REFERENCE:

The chart below can be used to determine sectors affected by a radiological release, through comparison with wind direction from the meteorological recorders in the Control Room.

If the wind direction is directly on the edge of two sectors (e.g., 11°, 33°, 56°, etc.), an additional sector should be added to the protective action recommendations. For example, if the wind direction is from 78°, then the affected sectors for PARs should be L, M, N and P.

SECTOR INFORMATION:

<u>WIND SECTOR</u>	<u>WIND FROM</u>	<u>DEGREES</u>	<u>WIND TOWARD</u>	<u>SECTORS AFFECTED</u>
[A]	N	348-11	S	HJK
[B]	NNE	11-33	SSW	JKL
[C]	NE	33-56	SW	KLM
[D]	ENE	56-78	WSW	LMN
[E]	E	78-101	W	MNP
[F]	ESE	101-123	WNW	NPQ
[G]	SE	123-146	NW	PQR
[H]	SSE	146-168	NNW	QRA
[J]	S	168-191	N	RAB
[K]	SSW	191-213	NNE	ABC
[L]	SW	213-236	NE	BCD
[M]	WSW	236-258	ENE	CDE
[N]	W	258-281	E	DEF
[P]	WNW	281-303	ESE	EFG
[Q]	NW	303-326	SE	FGH
[R]	NNW	326-348	SSE	GHJ

STABILITY CLASSIFICATION REFERENCE:

Either ERDADS or the below chart can be used to determine atmospheric stability classification for notification to the State of Florida. Primary method is from ΔT via the South Dade (60 meter) tower. Backup method is from Sigma Theta via the Ten Meter Tower. If neither meteorological tower is available, Stability Classification shall be determined using data from National Weather Service (See 0-EPIP-20126, Off-site Dose Calculations).

CLASSIFICATION OF ATMOSPHERIC STABILITY:

<u>Stability Classification</u>	<u>Pasquill Categories</u>	<u>Primary Delta T (°F)</u>	<u>Backup Sigma Theta Range (Degrees)</u>
Extremely unstable	A	$\Delta T \leq -1.7$	$ST \geq 22.5$
Moderately unstable	B	$-1.7 < \Delta T \leq -1.5$	$22.5 > ST \geq 17.5$
Slightly unstable	C	$-1.5 < \Delta T \leq -1.4$	$17.5 > ST \geq 12.5$
Neutral	D	$-1.4 < \Delta T \leq -0.5$	$12.5 > ST \geq 7.5$
Slightly stable	E	$-0.5 < \Delta T \leq +1.4$	$7.5 > ST \geq 3.8$
Moderately stable	F	$+1.4 < \Delta T \leq +3.6$	$3.8 > ST \geq 2.1$
Extremely stable	G	$+3.6 < \Delta T$	$2.1 > ST$

Meteorological information needed to fill out the Florida Nuclear Plant Emergency Notification Form is available from the Dose Calculation Worksheet (0-EPIP-20126). The Worksheet shall be filled out by Chemistry and given to the Emergency Coordinator.

**GUIDANCE FOR DETERMINING
PROTECTIVE ACTION RECOMMENDATIONS (PARS)
BASED ON PLANT CONDITIONS**

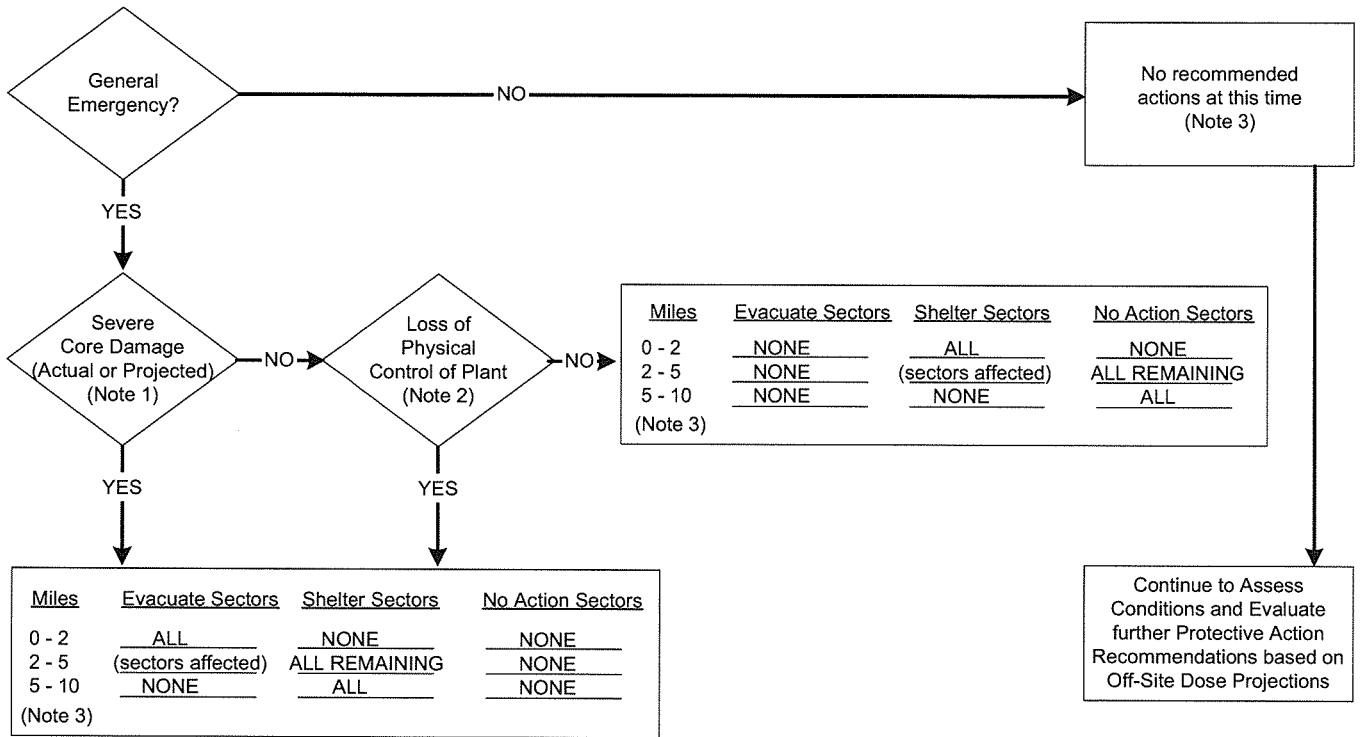

NOTES:

- (1) Severe core damage is indicated by any of the following:
 - Loss of critical functions required for core protection (e.g. loss of injection with LOCA)
 - High Core temperatures (Valid CET > 700°F)
 - CHRRM Reading of greater than or equal to 1.3E4 R/hr
- (2) Loss of physical control of Control Room or reactor operating areas required for continued safe plant operation to intruders.
- (3) See additional Guidance for Determining PARs in Emergency Plan Implementing Procedures.

BASED ON MANUAL DOSE CALCULATIONS

RELEASE DURATION LESS THAN 2 HOURS (PUFF RELEASE)

				Beyond 10 miles use this column and the 10 mile dose value.
Total Dose TEDE Dose (mRem)	Thyroid Dose CDE (mRem)	0-2 Miles Use 1 Mi. value	2-5 Miles Use 2 Mi. Value	5-10 Miles Use 5 Mi. Value
< 500 mRem	<1000 mRem	None	None	None
≥ 500 mRem but <1000 mRem	≥ 1000 mRem but <5000 mRem	S(ALL)	S(DW)	S(DW)
≥1000 mRem but <5000 mRem	≥ 5000 mRem but < 25000 mRem	S(ALL)	S(ALL)	S(ALL)
≥ 5000 mRem	≥ 25000 mRem	E(ALL)	E(DW)+S(AR)	E(DW)+S(AR)

RELEASE DURATION GREATER THAN OR EQUAL TO 2 HOURS

				Beyond 10 miles use this column and the 10 mile dose value.
Total Dose TEDE Dose (mRem)	Thyroid Dose CDE (mRem)	0-2 Miles Use 1 Mi. value	2-5 Miles Use 2 Mi. Value	5-10 Miles Use 5 Mi. Value
< 500 mRem	<1000 mRem	None	None	None
≥ 500 mRem but <1000 mRem	≥ 1000 mRem but <5000 mRem	S(ALL)	S(DW)	S(DW)
≥1000 mRem but <5000 mRem	≥ 5000 mRem but < 25000 mRem	E(ALL)	E(DW)+S(AR)	E(DW)+S(AR)
≥ 5000 mRem	≥ 25000 mRem	E(ALL)	E(ALL)	E(DW)+S(AR)

SUMMARY	0 - 2 MI.	2 - 5 MI.	5 - 10 MI.
PARs based on – Plant Conditions			
PARs based on – Total Dose (TEDE)			
PARs based on – Thyroid Dose (CDE)			
Most Conservative PARs based on Plant Conditions and Dose Projections			

LEGEND OF ABBREVIATIONS

- S – Sheltering recommended
- E – Evacuation recommended
- DW – Downwind plus 2 adjoining sectors
- AR – All Remaining sectors
- ALL – All Sectors

CAUTION

Previously issued PARs, unless found to be less conservative, are to remain in effect until the source of the threat is clearly under control.

FPL is required to provide county and state governmental authorities with recommendations for protective action to be taken by the public during radiological emergencies at the Turkey Point Nuclear Plant. The responsible authorities are the State Division of Emergency Management (DEM), Miami-Dade County Office of Emergency Management and Monroe County Office of Emergency Management.

Protective Action Recommendations (PARs) should be made utilizing all of the available data. This includes plant status, off-site dose projections, and/or field monitoring data. The more conservative recommendations should be made.

Beginning at the top left side, answer the **General Emergency** question. If yes, continue on, following the arrows, and answering the other question blocks. Record the PARs based on Plant Condition (A) in the Summary Block at the bottom of the page. From the PAR based on Plant Condition's block continue following arrow to next box, and determine PARs based on Off-site Dose Projections (B) Total Dose (TEDE) and Thyroid Dose (CDE). In determining PARs, both plant conditions AND off-site doses must be considered for all PARs. If a release has not occurred, then proceed with issuance of PARs from the plant condition determination.

To determine PARs from off-site doses, find the blocks that correspond with the Total Dose (TEDE) and Thyroid Dose (CDE) at 1, 2 and 5 miles from the Dose Calculation Worksheet (0-EPIP-20126). Follow across to the column that indicates the distance where that dose was found i.e., first block for 1 mile, second block for 2 miles, or third block for 5 miles. (B) Record the PARs based on Off-site Doses in the Summary Block. Once PARs are determined for all mile sectors for both Total Dose (TEDE) and Thyroid Dose (CDE) (B), then a comparison with the Plant Condition PARs (A) is performed, and the most conservative PARs for each mile sector is selected for issuance to off-site agencies.

The following example is provided:

EXAMPLE

A release has occurred at the Turkey Point Plant. The wind direction is from the SSE and the projected off-site accumulated Thyroid Dose (CDE) is 5,000 mRem at 1 mile, 1,000 mRem at 2 miles, and less than 1,000 mRem at 5 miles. The plant is in a General Emergency with CHRRM at 100 R/hr, no core damage indicators, and no loss of physical control of the plant.

Using the PAR Worksheet, the following recommendations should be made:

Based on our current assessment of all the information now available to use, Florida Power & Light Company recommends that you consider taking the following protective actions.

- A. EVACUATE all people between 0 and 2 miles from the plant.
- B. SHELTER all people between a 2 and 5 mile radius from the plant who are in Sectors Q, R, and A (refer to Attachment 1).
- C. No protective actions is recommended between a 5 and 10 mile radius from the plant.

Due to the large political and legal ramifications of these recommendations and the potential impact on FPL, the following guidelines, format, and content should be used.

- (1) If the emergency has not been classified as a GENERAL EMERGENCY and the off-site doses are LESS THAN 500 mRem Total Dose (TEDE) or 1,000 mRem Thyroid Dose (CDE) at 1 mile over the projected duration of the release, no protective action is recommended. When reporting to DEM and other off-site agencies who inquire, this should be reported in a manner similar to the following:

Based on our urgent assessment of all the information now available to us, Florida Power & Light Company recommends that you consider taking the following protective actions - NONE. This recommendation may change in the future, but we cannot now say when it may change or what the change may be.

- (2) When available, both plume calculation and off-site monitoring results should be evaluated when making protective action recommendations. If significant discrepancies exist between field monitoring results and plume dispersion calculations, then the discrepancy should be reviewed, and the appropriate value should be selected in the determination of protective action recommendations.
- (3) Thyroid Dose (CDE) Limits for PARs are based on adult thyroid. These limits are consistent with EPA Guidelines based on the following criteria:
 - a. Uncertainty and potential errors associated with age specific parameters, and
 - b. Level of conservatism in the adult values.
- (4) Loss of physical control of the plant to intruders shall be determined by the Emergency Coordinator based on the current operating mode requirements of the unit / plant, and the availability of equipment required for continued safe operation.

GUIDANCE FOR THE USE OF POTASSIUM IODIDE (KI) – A THYROID BLOCKING AGENT

1. The EOF RP Manager in consultation with the TSC RP Supervisor will determine the need to dispense Potassium Iodide (KI) based upon a projected or actual thyroid Committed Dose Equivalent (CDE) of greater than or equal to 5 rem. (The thyroid CDE of greater than or equal to 5 rem is based on the FDA recommended threshold for ingestion of KI by pregnant and lactating women).
2. The TSC RP Supervisor and the OSC RP Supervisor will coordinate KI distribution once a decision for use has been determined.
3. The TSC RP Supervisor is responsible for KI distribution to personnel in the Unit 3 and 4 Control Room and the TSC and Field Monitoring Teams and to Security personnel not assigned to the OSC.
4. The OSC RP Supervisor is responsible for distribution in the OSC.
5. KI should be administered and ingested within 2 hours after the determination is made that thyroid CDE is greater than or equal to 5 rem.
6. When KI is issued, thyroid intakes will be estimated by whole body counts.
7. Administering KI after an uptake may limit thyroid CDE depending on time after exposure.
8. Caution emergency response personnel of potential KI side effects if they are allergic to shellfish or iodide. Emergency response personnel who know they have such allergies should be replaced in lieu of directing them to ingest KI.
9. All KI tablets are stored in the RP kits in the Unit 3 and 4 Control Room, TSC, OSC, and Field Monitoring Team Kits.

Reference for Question #87

Tech Spec 3.5.2, ECCS Subsystems - Targ Greater Than
or Equal to 350°F, pp 3/4 5-3, 5-4,
5-5, 5-6, 5-7 and 5-8

EMERGENCY CORE COOLING SYSTEMS

3/4.5.2 ECCS SUBSYSTEMS - T_{avg} GREATER THAN OR EQUAL TO 350°F

LIMITING CONDITION FOR OPERATION

3.5.2 The following Emergency Core Cooling System (ECCS) equipment and flow paths shall be OPERABLE:

- a. Four OPERABLE Safety Injection (SI) pumps, each capable of being powered from its associated OPERABLE diesel generator[#], with discharge aligned to the RCS cold legs,*
- b. Two OPERABLE RHR heat exchangers,
- c. Two OPERABLE RHR pumps with discharge aligned to the RCS cold legs,
- d. An OPERABLE flow path capable of taking suction from the refueling water storage tank as defined in Specification 3.5.4, and
- e. Two OPERABLE flow paths capable of taking suction from the containment sump.

APPLICABILITY: MODES 1, 2, and 3**.

ACTION:

- a. With any one of the required ECCS components or flow paths inoperable, except for inoperable Safety Injection Pump(s) or an inoperable RHR pump, restore the inoperable component or flow path to OPERABLE status within 72 hours or be in at least HOT STANDBY within the next 6 hours and in HOT SHUTDOWN within the following 6 hours.
- b. In the event the ECCS is actuated and injects water in the Reactor Coolant System, a Special Report shall be prepared and submitted to the Commission pursuant to Specification 6.9.2 within 90 days describing the circumstances of the actuation and the total accumulated actuation cycles to date since January 1, 1990.
- c. With one of the four required Safety Injection pumps inoperable and the opposite unit in MODE 1, 2, or 3, restore the pump to OPERABLE status within 30 days or be in at least HOT STANDBY within the next 12 hours and in HOT SHUTDOWN within the following 6 hours.***

*Only three OPERABLE Safety Injection (SI) pumps (two associated with the unit and one from the opposite unit), each capable of being powered from its associated OPERABLE diesel generator[#], with discharge aligned to the RCS cold leg are required if the opposite unit is in MODE 4, 5, or 6.

**The provisions of Specifications 3.0.4 and 4.0.4 are not applicable for entry into MODE 3 for the Safety Injection flow paths isolated pursuant to Specification 3.4.9.3 provided that the Safety Injection flow paths are restored to OPERABLE status prior to T_{avg} exceeding 380°F. Safety Injection flow paths may be isolated when T_{avg} is less than 380°F.

***The provisions of Specifications 3.0.4 and 4.0.4 are not applicable.

[#]Inoperability of the required EDG's does not constitute inoperability of the associated Safety Injection pumps.

EMERGENCY CORE COOLING SYSTEMS

3/4.5.2 ECCS SUBSYSTEMS - T_{avg} GREATER THAN OR EQUAL TO 350°F

LIMITING CONDITION FOR OPERATION

- d. With two of the four required Safety Injection pumps inoperable and the opposite unit in MODE 1, 2, or 3, restore one of the two inoperable pumps to OPERABLE status within 72 hours or be in at least HOT STANDBY within the next 12 hours and in HOT SHUTDOWN within the following 6 hours. This ACTION applies to both units simultaneously.
- e. With one of the three required Safety Injection pumps inoperable and the opposite unit in MODE 4, 5, or 6, restore the pump to OPERABLE status within 72 hours or be in at least HOT STANDBY within the next 6 hours and in HOT SHUTDOWN within the following 6 hours.
- f. With a required Safety Injection pump OPERABLE but not capable of being powered from its associated diesel generator, restore the capability within 14 days or be in at least HOT STANDBY within the next 6 hours and in HOT SHUTDOWN within the following 6 hours.
- g. With an ECCS subsystem inoperable due to an RHR pump being inoperable, restore the inoperable RHR pump to OPERABLE status within 7 days or be in as least HOT STANDBY within the next 6 hours and in HOT SHUTDOWN within the following 6 hours.

EMERGENCY CORE COOLING SYSTEMS

SURVEILLANCE REQUIREMENTS

4.5.2 Each ECCS component and flow path shall be demonstrated OPERABLE:

- a. At least once per 12 hours by verifying by control room indication that the following valves are in the indicated positions with power to the valve operators removed:

<u>Valve Number</u>	<u>Valve Function</u>	<u>Valve Position</u>
864A and B	Supply from RWST to ECCS	Open
862A and B	RWST Supply to RHR pumps	Open
863A and B	RHR Recirculation	Closed
866A and B	H.H.S.I. to Hot Legs	Closed
HCV-758*	RHR HX Outlet	Open

To permit temporary operation of these valves for surveillance or maintenance purposes, power may be restored to these valves for a period not to exceed 24 hours.

- b. At least once per 31 days by:

- 1) Verifying that the ECCS piping is full of water by venting the ECCS pump casings and accessible discharge piping,
- 2) Verifying that each valve (manual, power-operated, or automatic) in the flow path that is not locked, sealed, or otherwise secured in position, is in its correct position, and
- 3) Verifying that each RHR Pump develops the indicated differential pressure applicable to the operating conditions in accordance with Figure 3.5-1 when tested pursuant to Specification 4.0.5.

- c. At least once per 92 days by:

- 1) Verifying that each SI pump develops the indicated differential pressure applicable to the operating conditions when tested pursuant to Specification 4.0.5.

SI pump ≥ 1083 psid at a metered flowrate ≥ 300 gpm (normal alignment or Unit 4 SI pumps aligned to Unit 3 RWST), or
 ≥ 1113 psid at a metered flowrate ≥ 280 gpm (Unit 3 SI pumps aligned to Unit 4 RWST).

*Air Supply to HCV-758 shall be verified shut off and sealed closed once per 31 days.

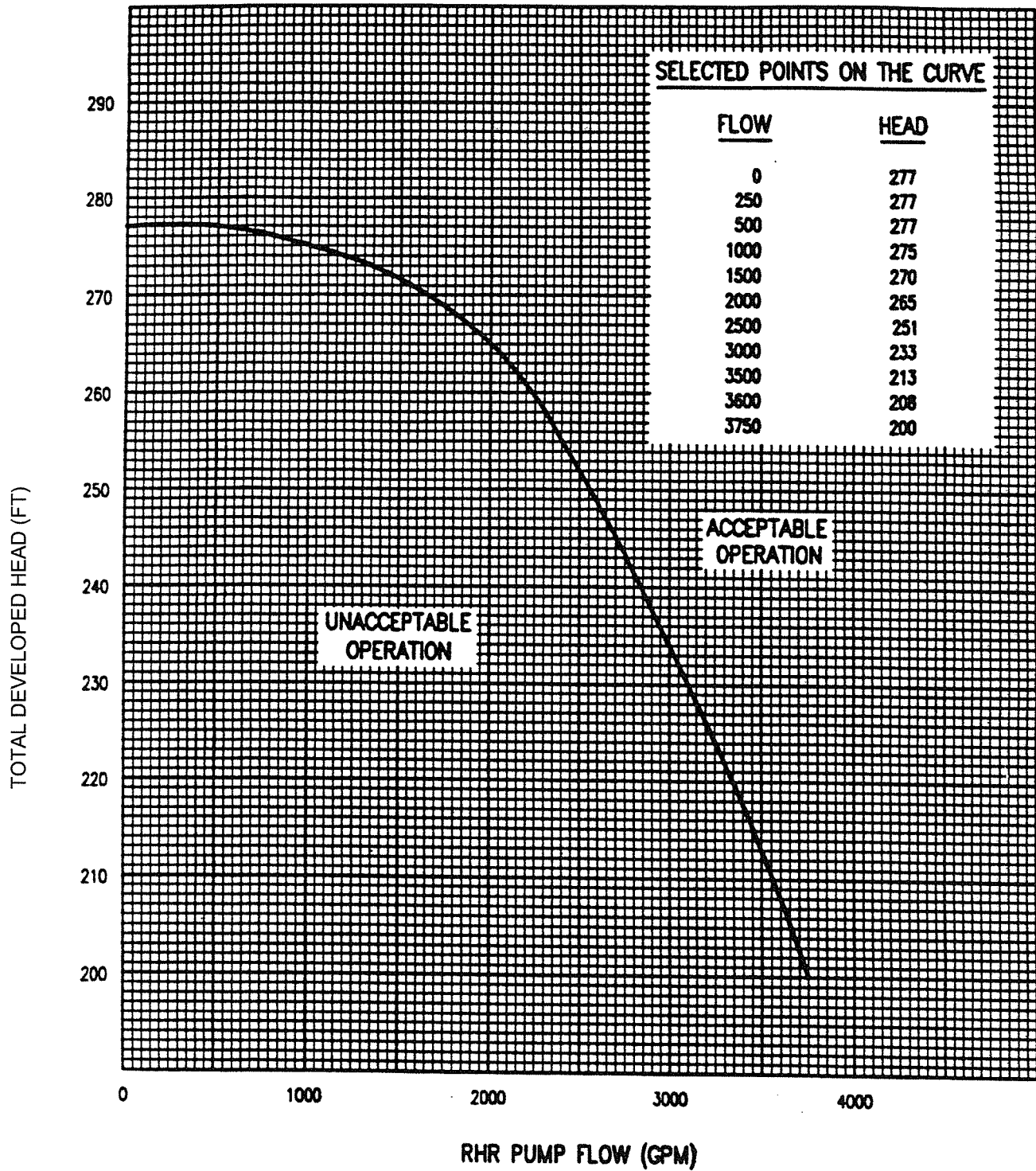

Figure 3.5-1
RHR Pump Curve

EMERGENCY CORE COOLING SYSTEMS

SURVEILLANCE REQUIREMENTS

- d. By a visual inspection which verifies that no loose debris (rags, trash, clothing, etc.) is present in the containment which could be transported to the containment sump and cause restriction of the pump suction during LOCA conditions. The visual inspection shall be performed:
 - 1) For all accessible areas of the containment prior to establishing CONTAINMENT INTEGRITY, and
 - 2) At least once daily of the areas affected within containment by containment entry and during the final entry when CONTAINMENT INTEGRITY is established.
- e. At least once per 18 months by:
 - 1) Verifying automatic isolation and interlock action of the RHR system from the Reactor Coolant System by ensuring that with a simulated or actual Reactor Coolant System pressure signal greater than or equal to 525 psig the interlocks cause the valves to automatically close and prevent the valves from being opened, and
 - 2) Verifying correct interlock action to ensure that the RWST is isolated from the RHR System during RHR System operation and to ensure that the RHR System cannot be pressurized from the Reactor Coolant System unless the above RWST Isolation Valves are closed.
 - 3) A visual inspection of the containment sump and verifying that the suction inlets are not restricted by debris and that the sump components (trash racks, screens, etc.) show no evidence of structural distress or abnormal corrosion.
- f. At least once per 18 months, during shutdown, by:
 - 1) Verifying that each automatic valve in the flow path actuates to its correct position on Safety Injection actuation test signal, and
 - 2) Verifying that each of the following pumps start automatically upon receipt of a Safety Injection actuation test signal:
 - a) Safety Injection pump, and
 - b) RHR pump.

EMERGENCY CORE COOLING SYSTEMS

SURVEILLANCE REQUIREMENTS

- g. By verifying the correct position of each electrical and/or mechanical position stop for the following ECCS throttle valves:
- 1) Within 4 hours following completion of each valve stroking operation or maintenance on the valve when the ECCS components are required to be OPERABLE, and
 - 2) At least once per 18 months.

RHR System
Valve Number

HCV-*-758
MOV-*-872

Reference for Question #88

Tech Spec 3.8.1.1, AC Sources -Operating, pp 3/4 8-1,
8-2, 8-3, 8-4, 8-4a, 8-5, 8-6, 8-7, 8-8, 8-9, and
8-10

3/4.8 ELECTRICAL POWER SYSTEMS

3/4.8.1 A.C. SOURCES

OPERATING

LIMITING CONDITION FOR OPERATION

3.8.1.1 As a minimum, the following A.C. electrical power sources shall be OPERABLE:

- a. Two startup transformers and their associated circuits, and
- b. Three separate and independent diesel generators* including,
 - 1) For Unit 3, two (3A and 3B); for Unit 4, one (3A or 3B) each with:
 - a) A separate skid-mounted fuel tank and a separate day fuel tank with an OPERABLE solenoid valve to permit gravity flow from the day tank to the skid mounted tank, and with the two tanks together containing a minimum of 2000 gallons of fuel oil.
 - b) A common Fuel Storage System containing a minimum volume of 38,000 gallons of fuel,**
 - c) A separate fuel transfer pump,**
 - d) Lubricating oil storage containing a minimum volume of 120 gallons of lubricating oil,
 - e) Capability to transfer lubricating oil from storage to the diesel generator unit, and
 - f) Energized MCC bus (MCC 3A vital section for EDG 3A, MCC 3K for EDG 3B).
 - 2) For Unit 3, one (4A or 4B); for Unit 4, two (4A and 4B) each with:
 - a) A separate day fuel tank containing a minimum volume of 230 gallons of fuel,
 - b) A separate Fuel Storage System containing a minimum volume of 34,700 gallons of fuel,
 - c) A separate fuel transfer pump, and
 - d) Energized MCC bus (MCC 4J for EDG 4A, MCC 4K for EDG 4B).

*Whenever one or more of the four EDG's is out-of-service, ensure compliance with the EDG requirements specified in Specifications 3.5.2 and 3.8.2.1.

**A temporary Class III fuel storage system containing a minimum volume of 38,000 gallons of fuel oil may be used for up to 10 days during the performance of Surveillance Requirement 4.8.1.1.2i.1 for the Unit 3 storage tank while Unit 3 is in Modes 5, 6, or defueled. If the diesel fuel oil storage tank is not returned to service within 10 days, Technical Specification 3.8.1.1 Action b and 3.8.1.2 Action apply to Unit 4 and Unit 3 respectively.

ELECTRICAL POWER SYSTEMS

LIMITING CONDITION FOR OPERATION (Continued)

APPLICABILITY: MODES 1, 2, 3, and 4.

ACTION:

- a. With one of two startup transformers or an associated circuit inoperable, demonstrate the OPERABILITY of the other startup transformer and its associated circuits by performing Surveillance Requirement 4.8.1.1.1.a within 1 hour and at least once per 8 hours thereafter. If the inoperable startup transformer is the associated startup transformer and became inoperable while the unit is in MODE 1, reduce THERMAL POWER to $\leq 30\%$ RATED THERMAL POWER within 24 hours, or restore the inoperable startup transformer and associated circuits to OPERABLE status within the next 48 hours or be in at least HOT STANDBY within the next 6 hours and in COLD SHUTDOWN within the following 30 hours. If THERMAL POWER is reduced to $\leq 30\%$ RATED THERMAL POWER within 24 hours or if the inoperable startup transformer is associated with the opposite unit restore the startup transformer and its associated circuits to OPERABLE status within 30 days of the loss of OPERABILITY, or be in at least HOT STANDBY within the next 12 hours and in COLD SHUTDOWN within the following 30 hours. If the inoperable startup transformer is the associated startup transformer and became inoperable while the unit was in MODE 2, 3, or 4 restore the startup transformer and its associated circuits to OPERABLE status within 24 hours or be in at least HOT STANDBY within 6 hours and in COLD SHUTDOWN within the following 30 hours. This ACTION applies to both units simultaneously.
- b. With one of the required diesel generators inoperable, demonstrate the OPERABILITY of the above required startup transformers and their associated circuits by performing Surveillance Requirement 4.8.1.1.1.a within 1 hour and at least once per 8 hours thereafter. If the diesel generator became inoperable due to any cause other than an inoperable support system, an independently testable component, or preplanned preventative maintenance or testing, demonstrate the OPERABILITY of the remaining required diesel generators by performing Surveillance Requirement 4.8.1.1.2.a.4 within 24 hours, unless the absence of any potential common mode failure for the remaining diesel generators is determined. If testing of remaining required diesel generators is required, this testing must be performed regardless of when the inoperable diesel generator is restored to OPERABILITY. Restore the inoperable diesel generator to OPERABLE status within 14 days** or be in at least HOT STANDBY within the next 6 hours and in COLD SHUTDOWN within the following 30 hours.
- c. With one startup transformer and one of the required diesel generators inoperable, demonstrate the OPERABILITY of the remaining A.C. sources by performing Surveillance Requirement 4.8.1.1.1.a on the remaining

** 72 hours if inoperability is associated with Action Statement 3.8.1.1.c.

ELECTRICAL POWER SYSTEMS

LIMITING CONDITION FOR OPERATION (Continued)

ACTION (Continued)

startup transformer and associated circuits within one hour and at least once per 8 hours thereafter; and if the diesel generator became inoperable due to any cause other than an inoperable support system, an independently testable component, or preplanned preventive maintenance or testing, demonstrate the OPERABILITY of the remaining required diesel generators by performing Surveillance Requirement 4.8.1.1.2a.4 within 8 hours, unless it can be confirmed that the cause of the inoperable diesel generator does not exist on the remaining required diesel generators, unless the diesel generators are already operating; restore one of the inoperable sources to OPERABLE status in accordance with Action Statements a and b, as appropriate. If testing of remaining required diesel generators is required, this testing must be performed regardless of when the inoperable diesel generator is restored to OPERABILITY. Notify the NRC within 4 hours of declaring both a start-up transformer and diesel generator inoperable. Restore the other A.C. power source (startup transformer or diesel generator) to OPERABLE status in accordance with the provisions of Section 3.8.1.1 Action Statement a or b, as appropriate, with the time requirement of that Action Statement based on the time of initial loss of the remaining inoperable A.C. power source.

- d. With one diesel generator inoperable, in addition to ACTION b. or c. above, verify that:
1. All required systems, subsystems, trains, components, and devices (except safety injection pumps) that depend on the remaining required OPERABLE diesel generators as a source of emergency power are also OPERABLE.

If this condition is not satisfied within 2 hours, be in at least HOT STANDBY within the next 6 hours and in COLD SHUTDOWN within the following 30 hours.
 2. At least two Safety Injection pumps are OPERABLE and capable of being powered from their associated OPERABLE diesel generators.

If this condition is not satisfied within 2 hours, be in at least HOT STANDBY within the next 12 hours and in HOT SHUTDOWN within the following 6 hours. This ACTION applies to both units simultaneously.
- e. With two of the above required startup transformers or their associated circuits inoperable notify the NRC within 4 hours; restore at least one of the inoperable startup transformers to OPERABLE status within 24 hours or be in at least HOT STANDBY within the next 6 hours* and in COLD

*If the opposite unit is shutdown first, this time can be extended to 42 hours.

ELECTRICAL POWER SYSTEMS

LIMITING CONDITION FOR OPERATION (Continued)

ACTION (Continued)

SHUTDOWN within the following 30 hours. This ACTION applies to both units simultaneously. With only one startup transformer and associated circuits restored, perform Surveillance Requirement 4.8.1.1.1a on the OPERABLE Startup transformer at least once per 8 hours, and restore the other startup transformer and its associated circuits to OPERABLE status or shutdown in accordance with the provisions of Action Statement 3.8.1.1a with time requirements of that Action Statement based on the time of initial loss of a startup transformer. This ACTION applies to both units simultaneously.

- f. With two of the above required diesel generators inoperable, demonstrate the OPERABILITY of two startup transformers and their associated circuits by performing the requirements of Specification 4.8.1.1.1a. within 1 hour and at least once per 8 hours thereafter; restore at least one of the inoperable diesel generators to OPERABLE status within 2 hours or be in at least HOT STANDBY within the next 6 hours and in COLD SHUTDOWN within the following 30 hours. Restore all required diesel generators to OPERABLE status within 14 days from time of initial loss or be in at least HOT STANDBY within the next 6 hours and in COLD SHUTDOWN within the following 30 hours.
- g. Following the addition of the new fuel oil* to the Diesel Fuel Oil Storage Tanks, with one or more diesel generators with new fuel oil properties outside the required Diesel Fuel Oil Testing Program limits, restore the stored fuel oil properties to within the required limits within 30 days.
- h. With one or more diesel generators with stored fuel oil total particulates outside the required Diesel Fuel Oil Testing Program limits, restore the fuel oil total particulates to within the required limits within 7 days.

* The properties of API Gravity, specific gravity or an absolute specific gravity; kinematic viscosity; clear and bright appearance; and flash point shall be confirmed to be within the Diesel Fuel Oil Testing Program limits, prior to the addition of the new fuel oil to the Diesel Fuel Oil Storage Tanks.

ELECTRICAL POWER SYSTEMS

SURVEILLANCE REQUIREMENTS

- 4.8.1.1.1 Each of the above required startup transformers and their associated circuits shall be:
- a. Determined OPERABLE at least once per 7 days by verifying correct breaker alignments, indicated power availability, and
 - b. Demonstrated OPERABLE at least once per 18 months while shutting down, by transferring manually unit power supply from the auxiliary transformer to the startup transformer.

ELECTRICAL POWER SYSTEMS

SURVEILLANCE REQUIREMENTS (Continued)

- 4.8.1.1.2 Each diesel generator shall be demonstrated OPERABLE*:
- a. At least once per 31 days on a STAGGERED TEST BASIS by:
- 1) Verifying the fuel volume in the day and skid-mounted fuel tanks (Unit 4-day tank only),
 - 2) Verifying the fuel volume in the fuel storage tank,
 - 3) Verifying the lubricating oil inventory in storage,
 - 4) Verifying the diesel starts and accelerates to reach a generator voltage and frequency of 4160 ± 420 volts and 60 ± 1.2 Hz. Once per 184 days, these conditions shall be reached within 15 seconds after the start signal from normal conditions. For all other starts, warmup procedures, such as idling and gradual acceleration as recommended by the manufacturer may be used. The diesel generator shall be started for this test by using one of the following signals:
 - a) Manual, or
 - b) Simulated loss-of-offsite power by itself, or
 - c) Simulated loss-of-offsite power in conjunction with an ESF Actuation test signal, or
 - d) An ESF Actuation test signal by itself.
 - 5) Verifying the generator is synchronized, loaded** to 2300 - 2500 kW (Unit 3), 2650-2850 kW (Unit 4)***, operates at this loaded condition for at least 60 minutes and for Unit 3 until automatic transfer of fuel from the day tank to the skid mounted tank is demonstrated, and the cooling system is demonstrated OPERABLE.
 - 6) Verifying the diesel generator is aligned to provide standby power to the associated emergency busses.

* All diesel generator starts for the purpose of these surveillances may be preceded by a prelube period as recommended by the manufacturer.

** May include gradual loading as recommended by the manufacturer so that the mechanical stress and wear on the diesel engine is minimized.

***Momentary transients outside these load bands do not invalidate this test.

ELECTRICAL POWER SYSTEMS

SURVEILLANCE REQUIREMENTS (Continued)

- b. Demonstrating at least once per 92 days that a fuel transfer pump starts automatically and transfers fuel from the storage system to the day tank,
- c. At least once per 31 days and after each operation of the diesel where the period of operation was greater than or equal to 1 hour by checking for and removing accumulated water from the day and skid-mounted fuel tanks (Unit 4-day tank only);
- d. At least once per 31 days by checking for and removing accumulated water from the fuel oil storage tanks;
- e. By verifying fuel oil properties of new fuel oil are tested in accordance with, and maintained within the limits of, the Diesel Fuel Oil Testing Program.
- f. By verifying fuel oil properties of stored fuel oil are tested in accordance with, and maintained within the limits of, the Diesel Fuel Oil Testing Program.
- g. At least once per 18 months, during shutdown (applicable to only the two diesel generators associated with the unit):
 - 1) Deleted
 - 2)* Verifying the generator capability to reject a load of greater than or equal to 380 kw while maintaining voltage at 4160 ± 420 volts and frequency at 60 ± 1.2 Hz;
 - 3)* Verifying the generator capability to reject a load of greater than or equal to 2500 kW (Unit 3), 2874 kW (Unit 4) without tripping. The generator voltage shall return to less than or equal to 4784 volts within 2 seconds following the load rejection;
 - 4) Simulating a loss-of-offsite power by itself, and:
 - a) Verifying deenergization of the emergency busses and load shedding from the emergency busses, and
 - b. Verifying the diesel starts on the auto-start signal, energizes the emergency busses with any permanently

* For the purpose of this test, warmup procedures, such as idling, gradual acceleration, and gradual loading as recommended by the manufacturer may be used.

ELECTRICAL POWER SYSTEMS

SURVEILLANCE REQUIREMENTS (Continued)

- connected loads within 15 seconds, energizes the auto-connected shutdown loads through the load sequencer and operates for greater than or equal to 5 minutes while its generator is loaded with the auto-connected shutdown loads. After automatic load sequencing, the steady-state voltage and frequency of the emergency busses shall be maintained at 4160 ± 420 volts and 60 ± 1.2 Hz during this test.
- 5) Verifying that on an ESF Actuation test signal, without loss-of-offsite power, the diesel generator starts on the auto-start signal and operates on standby for greater than or equal to 5 minutes. The generator voltage and frequency shall be 4160 ± 420 volts and 60 ± 1.2 Hz within 15 seconds after the auto-start signal; the steady-state generator voltage and frequency shall be maintained within these limits during this test;
- 6) Simulating a loss-of-offsite power in conjunction with an ESF Actuation test signal, and:
- a) Verifying deenergization of the emergency busses and load shedding from the emergency busses;
 - b) Verifying the diesel starts on the auto-start signal, energizes the emergency busses with any permanently connected loads within 15 seconds, energizes the auto-connected emergency (accident) loads through the load sequencer and operates for greater than or equal to 5 minutes while its generator is loaded with the emergency loads. After automatic load sequencing, the steady-state voltage and frequency of the emergency busses shall be maintained at 4160 ± 420 volts and 60 ± 1.2 Hz during this test; and
 - c) Verifying that diesel generator trips that are made operable during the test mode of diesel operation are inoperable.
- 7)* # Verifying the diesel generator operates for at least 24 hours. During the first 2 hours of this test, the diesel generator shall be loaded to 2550-2750 kW (Unit 3), 2950-3150 kW (Unit 4)** and during the remaining 22 hours of this test, the diesel generator shall be loaded to 2300-2500 kW (Unit 3), 2650-2850 kW (Unit 4)**. The generator voltage and frequency shall be 4160 ± 420 volts and 60 ± 1.2 Hz within 15 seconds after the start signal; the steady-state generator voltage and frequency

* For the purpose of this test, warmup procedures, such as idling, gradual acceleration, and gradual loading as recommended by the manufacturer may be used.

** Momentary transients outside these load bands do not invalidate this test.

This test may be performed during POWER OPERATION

ELECTRICAL POWER SYSTEMS

SURVEILLANCE REQUIREMENTS (Continued)

shall be maintained within these limits during this test. Within 5 minutes after completing this 24-hour test, verify the diesel starts and accelerates to reach a generator voltage and frequency of 4160 ± 420 volts and 60 ± 1.2 Hz within 15 seconds after the start signal. **

- 8) Verifying that the auto-connected loads to each diesel generator do not exceed 2500 kW (Unit 3), 2874 kW (Unit 4);
- 9) Verifying the diesel generator's capability to:
 - a) Synchronize with the offsite power source while the generator is loaded with its emergency loads upon a simulated restoration of offsite power,
 - b) Transfer its loads to the offsite power source, and
 - c) Be restored to its standby status.
- 10) Verifying that the diesel generator operating in a test mode, connected to its bus, a simulated Safety Injection signal overrides the test mode by: (1) returning the diesel generator to standby operation, and (2) automatically energizing the emergency loads with offsite power;
- 11) Verifying that the fuel transfer pump transfers fuel from the fuel storage tank (Unit 3), fuel storage tanks (Unit 4) to the day tanks of each diesel associated with the unit via the installed cross-connection lines;
- 12) Verifying that the automatic load sequence timer is OPERABLE with the interval between each load block within $\pm 10\%$ of its design interval;
- 13) Verifying that the diesel generator lockout relay prevents the diesel generator from starting;

** If verification of the diesel's ability to restart and accelerate to a generator voltage and frequency of 4160 ± 420 volts and 60 ± 1.2 Hz within 15 seconds following the 24 hour operation test of Specification 4.8.1.1.2.g.7) is not satisfactorily completed, it is not necessary to repeat the 24-hour test. Instead, the diesel generator may be operated between 2300-2500 kW Unit 3, 2650-2850 kW (Unit 4) for 2 hours or until operating temperature has stabilized (whichever is greater). Following the 2 hours/operating temperature stabilization run, the EDG is to be secured and restarted within 5 minutes to confirm its ability to achieve the required voltage and frequency within 15 seconds.

ELECTRICAL POWER SYSTEMS

SURVEILLANCE REQUIREMENTS (Continued)

- h. At least once per 10 years or after any modifications which could affect diesel generator interdependence by starting all required diesel generators simultaneously and verifying that all required diesel generators provide 60 ± 1.2 Hz frequency and 4160 ± 420 volts in less than or equal to 15 seconds: and
- i. At least once per 10 years by:
 - 1) Draining each fuel oil storage tank, removing the accumulated sediment and cleaning the tank.*
 - 2) For Unit 4 only, performing a pressure test of those portions of the diesel fuel oil system designed to Section III, subsection ND of the ASME Code in accordance with Section XI of the ASME Boiler and Pressure Vessel Code and applicable Addenda.

4.8.1.1.3 Reports - (Not Used)

* A temporary Class III fuel storage system containing a minimum volume of 38,000 gallons of fuel oil may be used for up to 10 days during the performance of Surveillance Requirement 4.8.1.1.2i.1 for the Unit 3 storage tank while Unit 3 is in Modes 5, 6, or defueled. If the diesel fuel oil storage tank is not returned to service within 10 days, Technical Specification 3.8.1.1 Action b and 3.8.1.2 Action apply to Unit 4 and Unit 3 respectively.

TABLE 4.8-1

(Not Used)

Reference for Question #90

Tech Spec 3.7.3, Intake Cooling Water System, pp 3/4 7-14.

PLANT SYSTEMS

3/4.7.3 INTAKE COOLING WATER SYSTEM

LIMITING CONDITION FOR OPERATION

3.7.3 The Intake Cooling Water System (ICW) shall be OPERABLE with:

- a. Three ICW pumps, and
- b. Two ICW headers.

APPLICABILITY: MODES 1, 2, 3, and 4.

ACTION:

- a. With only two ICW pumps with independent power supplies OPERABLE, restore the inoperable ICW pump to OPERABLE status within 14 days or be in HOT STANDBY within the next 6 hours and in COLD SHUTDOWN within the following 30 hours. The provisions of Specification 3.0.4 are not applicable.
- b. With only one ICW pump OPERABLE or with two ICW pumps OPERABLE but not from independent power supplies, restore two pumps from independent power supplies to OPERABLE status within 72 hours or be in HOT STANDBY within the next 6 hours and in COLD SHUTDOWN within the following 30 hours.
- c. With only one ICW header OPERABLE, restore two headers to OPERABLE status within 72 hours or be in HOT STANDBY within the next 6 hours and in COLD SHUTDOWN within the following 30 hours.

SURVEILLANCE REQUIREMENTS

4.7.3 The Intake Cooling Water System (ICW) shall be demonstrated OPERABLE:

- a. At least once per 31 days by verifying that each valve (manual, power-operated, or automatic) servicing safety-related equipment that is not locked, sealed, or otherwise secured in position is in its correct position; and
- b. At least once per 18 months during shutdown, by verifying that:
 - 1) Each automatic valve servicing safety-related equipment actuates to its correct position on a SI test signal, and
 - 2) Each Intake Cooling Water System pump starts automatically on a SI test signal.
 - 3) Interlocks required for system operability are OPERABLE.

Reference for Question #93

Picture of Q SPDS CET/HJTC Channel A
Display

Teh Spec 3.3.3.3, Accident Monitoring Instrumentation,
pp 3/4-3-41, 3-43, 3-44, 3-45

DATE - TODAY
TIME - NOW

28 PDS MENU

PTN
UNIT 3

QSPDS CET/HJTC
CHANNEL A

Process

HEATED JUNCTION THERMOCOUPLES

HEATER POWER		THERMOCOUPLE TEMPERATURES	
HEATER %	SENSOR	HEATED F	UNHEATED F
1	80	585	544
2	80	601	548
3	80	585	544
4	80	601	545
5	80	607	546
6	80	613	547
7	80	619	547
8	80	625	548

DIFFERENTIAL

SENSOR	DIFFERENTIAL F
1	50
2	52
3	51
4	56
5	61
6	66
7	71
8	77

CALCULATED CET DATA

HIGHEST TEMPERATURE		NEXT HIGHEST TEMPERATURE	
QUAD	ID	QUAD	ID
1	3	1	4
2	5	2	2
3	4	3	1
4	3	4	4

FIVE HIGHEST CET TEMPERATURES

QUAD	ID	F
1	2	547
2	3	547
3	1	546
4	1	546
5	4	546
6	5	546

CORE EXIT THERMOCOUPLES

QUADRANT 1		QUADRANT 2	
CET	LOC	CET	LOC
1	P7	1	M3
2	N10	2	H5
3	N8	3	H3
4	L6	4	G2
5	K8	5	E4
		6	D3

QUADRANT 3

CET	LOC	F
1	L14	2300
2	L12	2300
3	J12	546
4	J10	545
5	H11	546
6	G16	546
7	F13	546
8	F11	546

QUADRANT 4

CET	LOC	F
1	G8	546
2	E10	2300
3	E7	2300
4	D6	547
5	C12	546
6	C8	2300
7	A8	546

System

PRIMARY

SECONDARY

POWER

ESF

SUPPORT SYS

EMERG RESP

UTILITIES

LEGEND

ALARMS

TRENDS

PRINT

PREVIOUS

INSTRUMENTATION

ACCIDENT MONITORING INSTRUMENTATION

LIMITING CONDITION FOR OPERATION

3.3.3.3 The accident monitoring instrumentation channels shown in Table 3.3-5 shall be OPERABLE.

APPLICABILITY: As shown in Table 3.3-5.

ACTION:

- a. As shown in Table 3.3-5.
- b. The provisions of Specification 3.0.4 are not applicable to ACTIONS in Table 3.3-5 that require a shutdown.
- c. Separate Action entry is allowed for each Instrument.

SURVEILLANCE REQUIREMENTS

4.3.3.3 Each accident monitoring instrumentation channel shall be demonstrated OPERABLE by performance of the CHANNEL CHECK and CHANNEL CALIBRATION at the frequencies shown in Table 4.3-4.

TABLE 3.3-5 (Continued)

ACCIDENT MONITORING INSTRUMENTATION

<u>INSTRUMENT</u>	<u>TOTAL NO. OF CHANNELS</u>	<u>MINIMUM CHANNELS OPERABLE</u>	<u>APPLICABLE MODES</u>	<u>ACTIONS</u>
14. In Core Thermocouples (Core Exit Thermocouples)	4/core quadrant	2/core quadrant	1, 2, 3	31, 32
15. Containment High Range Area Radiation	2	1	1, 2, 3	34
16. Reactor Vessel Level Monitoring System	2(1)	1(1)	1, 2, 3	37, 38
17. Neutron Flux, Backup NIS (Wide Range)	2	1	1, 2, 3	31, 32
18. DELETED				
19. High Range-Noble Gas Effluent Monitors				
a. Plant Vent Exhaust	1	1	ALL	34
b. Unit 3-Spent Fuel Pit Exhaust	1	1	ALL	34
c. Condenser Air Ejectors	1	1	1, 2, 3	34
d. Main Steam Lines	1	1	1, 2, 3	34
20. RWST Water Level	2	1	1, 2, 3	31, 32
21. Steam Generator Water Level (Narrow Range)	2/stm. Gen.	1/stm. Gen.	1, 2, 3	31, 32
22. Containment Isolation Valve Position Indication*	1/valve	1/valve	1, 2, 3	39

TABLE NOTATIONS

1. A channel is eight sensors in a probe. A channel is OPERABLE if a minimum of four sensors are OPERABLE.
2. Inputs to this instrument are from instrument items 3, 4, 5 and 14 of this Table.

* Applicable for containment isolation valve position indication designated as post-accident monitoring instrumentation (containment isolation valves which receive containment isolation Phase A, Phase B, or containment ventilation isolation signals).

TABLE 3.3-5 (Continued)

ACTION STATEMENTS

- ACTION 31 With the number of OPERABLE accident monitoring instrumentation channel(s) less than the Total Number of Channels either restore the inoperable channel(s) to OPERABLE status within 30 days, or submit a Special Report to the Commission pursuant to Specification 6.9.2 within the next 14 days outlining the action taken, the cause of the inoperability, and the plans and schedule for restoring the system to OPERABLE status.
- ACTION 32 With the number of OPERABLE accident monitoring instrumentation channels less than the Minimum Channels OPERABLE, either restore the inoperable channel(s) to OPERABLE status within 7 days, or be in at least HOT STANDBY within the next 6 hours and in at least HOT SHUTDOWN within the following 6 hours.
- ACTION 33 Close the associated block valve and open its circuit breaker.
- ACTION 34 With the number of OPERABLE Channels less than required by the Minimum Channels OPERABLE requirements, initiate the preplanned alternate method of monitoring the appropriate parameter(s), within 72 hours, and:
- 1) Either restore the inoperable channel(s) to OPERABLE status within 7 days of the event, or
 - 2) Prepare and submit a Special Report to the Commission pursuant to Specification 6.9.2 within the next 14 days outlining the action taken, the cause of the inoperability, and the plans and schedule for restoring the system to OPERABLE status.
- ACTION 35 DELETED
- ACTION 36 With the number of OPERABLE accident monitoring instrumentation channels less than the Minimum Channel OPERABLE, either restore the inoperable channel to OPERABLE status within 30 days, or be in at least HOT STANDBY within the next 6 hours and in at least HOT SHUTDOWN within the following 6 hours.
- ACTION 37 With the number of OPERABLE channels one less than the Total Number of Channels, restore the system to OPERABLE status within 30 days. If repairs are not feasible without shutting down, prepare and submit a Special Report to the Commission pursuant to Specification 6.9.2 within the next 14 days outlining the action taken, the cause of the inoperability and the plans and schedule for restoring the system to OPERABLE status.

TABLE 3.3-5 (Continued)

ACTION STATEMENTS

ACTION 38 With the number of OPERABLE channels less than the Minimum Channels OPERABLE requirements, restore the inoperable channel(s) to OPERABLE status within 7 days. If repairs are not feasible without shutting down:

1. Initiate an alternate method of monitoring the reactor vessel inventory; and
2. Prepare and submit a Special Report to the Commission pursuant to Specification 6.9.2 within the next 14 days outlining the action taken, the cause of the inoperability and the plans and schedule for restoring the system to OPERABLE status; and
3. Restore at least one channel to OPERABLE status at the next scheduled refueling.

ACTION 39 With the number of OPERABLE channels less than the Minimum Channels OPERABLE requirement, verify position by an alternate means (e.g. administrative controls, ERDADS, alternate position indication, or visual observation) within 2 hours, and restore the inoperable channel(s) within 7 days, or comply with the provisions of Specification 3.6.4 for an inoperable containment isolation valve.

Reference for Question #95

*Tech Spec 3.4.9.3, Overpressure Mitigating Systems,
pp 3/4 4-36, 4-37,*

REACTOR COOLANT SYSTEM

OVERPRESSURE MITIGATING SYSTEMS

LIMITING CONDITION FOR OPERATION

3.4.9.3 The high pressure safety injection flow paths to the Reactor Coolant System (RCS) shall be isolated, and at least one of the following Overpressure Mitigating Systems shall be OPERABLE:

- a. Two power-operated relief valves (PORVs) with a lift setting of ≤ 468 psig, or
- b. The RCS depressurized with a RCS vent of greater than or equal to 2.20 square inches.

APPLICABILITY MODES 4 (when the temperature of any RCS cold leg is less than or equal to 275°F), 5, and 6 with the reactor vessel head on.

ACTION:

- a. With the high pressure safety injection flow paths to the RCS unisolated, restore isolation of these flow paths within 4 hours.
- b. With one PORV inoperable in MODE 4 (when the temperature of any RCS cold leg is less than or equal to 275°F), restore the inoperable PORV to OPERABLE status within 7 days or depressurize and vent the RCS through at least a 2.20 square inch vent within the next 8 hours.
- c. With one PORV inoperable in Modes 5 or 6 with the reactor vessel head on, either (1) restore the inoperable PORV to OPERABLE status within 24 hours, or (2) complete depressurization and venting of the RCS through at least a 2.20 square inch vent within a total of 32 hours, or (3) complete depressurization and venting of the RCS through at least one open PORV and associated block valve within a total of 32 hours.
- d. With both PORVs inoperable, either restore one PORV to OPERABLE status or complete depressurization and venting of the RCS through at least a 2.20 square inch vent within 24 hours.
- e. In the event either the PORVs or a 2.20 square inch vent is used to mitigate an RCS pressure transient, a Special Report shall be prepared and submitted to the Commission pursuant to Specification 6.9.2 within 30 days. The report shall describe the circumstances initiating the transient, the effect of the PORVs or RCS vent(s) on the transient, and any corrective action necessary to prevent recurrence. A Special Report is not required when such a transient is the result of water injection into the RCS for test purposes with an open vent path.
- f. The provisions of Specification 3.0.4 are not applicable.

REACTOR COOLANT SYSTEM

OVERPRESSURE MITIGATING SYSTEMS

SURVEILLANCE REQUIREMENTS

- 4.4.9.3.1 Each PORV shall be demonstrated OPERABLE by:
- a. Performance of an ANALOG CHANNEL OPERATIONAL TEST* on the PORV actuation channel, but excluding valve operation, within 31 days prior to entering a condition in which the PORV is required OPERABLE and at least once per 31 days thereafter when the PORV is required OPERABLE.
 - b. Performance of a CHANNEL CALIBRATION on the PORV actuation channel at least once per 18 months; and
 - c. Verifying the PORV block valve is open at least once per 72 hours when the PORV is being used for overpressure protection.
 - d. While the PORVs are required to be OPERABLE, the backup nitrogen supply shall be verified OPERABLE at least once per 24 hours.*
- 4.4.9.3.2 The 2.20 square inch vent shall be verified to be open at least once per 12 hours** when the vent(s) is being used for overpressure protection.
- 4.4.9.3.3 Verify the high pressure injection flow path to the RCS is isolated at least once per 24 hours by closed valves with power removed or by locked closed manual valves.

* Not required to be met until 12 hours after decreasing RCS cold leg temperature to $\leq 275^{\circ}\text{F}$.

** Except when the vent pathway is provided with a valve which is locked, sealed, or otherwise secured in the open position, then verify these valves open at least once per 31 days.

Reference for Questions # 76, 77, 83, 84, and 99

Turkey Point EAL Classification Tables

F-668, Hot Conditions pp 1-35

F-669, Cold Conditions pp 1-31

HOT CONDITIONS TABLE INDEX

PAGE
2

INITIATING CONDITIONS MATRIX

RECOGNITION CATEGORIES

R – Abnormal Rad Levels / Radiological Effluent..... 4-8

 Radiological Effluent..... 6

 Abnormal Rad Levels..... 8

F – Fission Product Barrier Degradation..... 10-12

 Core Exit Thermocouple Readings..... 11

 Containment Isolation Failure or Bypass..... 11

 Containment Pressure..... 11

 Containment Radiation Monitors..... 11

 Emergency Coordinator Judgment..... 11

 Primary Coolant Activity Level..... 11

 RCS Leak Rate..... 11

 Reactor Vessel Water Level..... 11

 Safety Function Status..... 11

 SG Secondary Side Release with P – to – S Leakage..... 11

 SG Tube Rupture..... 11

 Worksheet..... 11

S – System Malfunctions..... 14-20

 AC Power..... 16

 Annunciators..... 18

 Communications..... 20

 DC Power..... 16

 Failure of Reactor Protection / Criticality..... 16

 Fuel Clad..... 18

 RCS Leakage..... 18

 Tech Specs..... 18

H – Hazards and Other Conditions Affecting Plant Safety..... 22-28

 Control Room Evacuation..... 28

 Discretionary..... 30

 Fire / Explosion..... 26

 Natural or Man-Made Events..... 24

 Security..... 28

 Toxic / Flammable Gas..... 26

E – Events Related to ISFSI (Independent Spent Fuel Storage Installation) 32-34

HOT CONDITIONS TABLE
(RCS > 200°F)

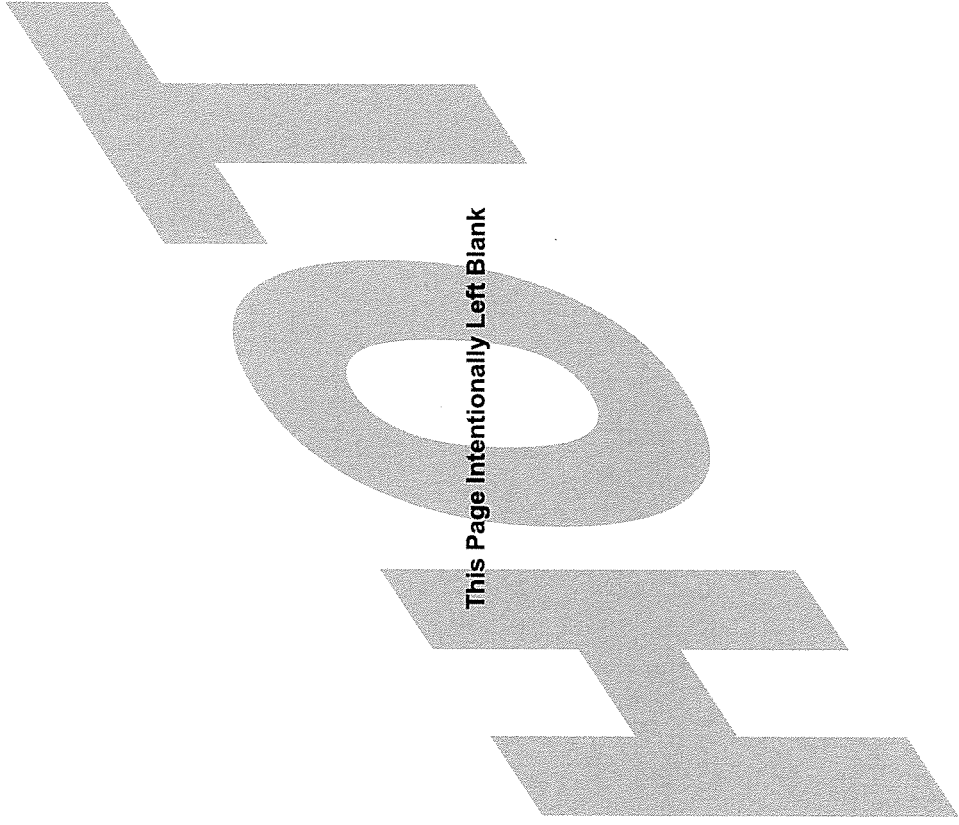

This Page Intentionally Left Blank

R - ABNORMAL RAD LEVELS/RADIOLOGICAL EFFLUENT		H - HAZARDS AND OTHER CONDITIONS AFFECTING PLANT SAFETY			E - EVENTS RELATED TO EP/IP Reference	
RADIODILOGICAL EFFLUENT	RG1	RG2	RG3	RG4	RG5	RG6
ABNORMAL RAD LEVELS	RA1	RA2	RA3	RA4	RA5	RA6
FISSION PRODUCT BREAKERS	FB1	FB2	FB3	FB4	FB5	FB6
FAILURE OF AC POWER	FS1	FS2	FS3	FS4	FS5	FS6
ANNUNCIATORS	SA1	SA2	SA3	SA4	SA5	SA6
RCS LEAK	SL1	SL2	SL3	SL4	SL5	SL6
FUEL CLAD	FL1	FL2	FL3	FL4	FL5	FL6
TECH SPECS	TS1	TS2	TS3	TS4	TS5	TS6
CONM	CM1	CM2	CM3	CM4	CM5	CM6
S - SYSTEM MALFUNCTIONS		E - EVENTS RELATED TO EP/IP Reference			E - EVENTS RELATED TO EP/IP Reference	
DC POWER	SP1	SP2	SP3	SP4	SP5	SP6
ANNUNCIATORS	SA1	SA2	SA3	SA4	SA5	SA6
RCS LEAK	SL1	SL2	SL3	SL4	SL5	SL6
FUEL CLAD	FL1	FL2	FL3	FL4	FL5	FL6
TECH SPECS	TS1	TS2	TS3	TS4	TS5	TS6
CONM	CM1	CM2	CM3	CM4	CM5	CM6
S - SYSTEM MALFUNCTIONS		H - HAZARDS AND OTHER CONDITIONS AFFECTING PLANT SAFETY			E - EVENTS RELATED TO EP/IP Reference	
DC POWER	SP1	SP2	SP3	SP4	SP5	SP6
ANNUNCIATORS	SA1	SA2	SA3	SA4	SA5	SA6
RCS LEAK	SL1	SL2	SL3	SL4	SL5	SL6
FUEL CLAD	FL1	FL2	FL3	FL4	FL5	FL6
TECH SPECS	TS1	TS2	TS3	TS4	TS5	TS6
CONM	CM1	CM2	CM3	CM4	CM5	CM6
S - SYSTEM MALFUNCTIONS		H - HAZARDS AND OTHER CONDITIONS AFFECTING PLANT SAFETY			E - EVENTS RELATED TO EP/IP Reference	
DC POWER	SP1	SP2	SP3	SP4	SP5	SP6
ANNUNCIATORS	SA1	SA2	SA3	SA4	SA5	SA6
RCS LEAK	SL1	SL2	SL3	SL4	SL5	SL6
FUEL CLAD	FL1	FL2	FL3	FL4	FL5	FL6
TECH SPECS	TS1	TS2	TS3	TS4	TS5	TS6
CONM	CM1	CM2	CM3	CM4	CM5	CM6
	Off-site Dose Resulting from an Actual or IMMINENT Release of Gaseous Radioactivity Greater Than 1000 mrem per Year or Projected Duration of the Release Using Actual Meteorology. Pg. 6	Off-site Dose Resulting from an Actual or IMMINENT Release of Gaseous Radioactivity Greater Than 100 mrem per Year or Projected Duration of the Release. Pg. 6	Any Release of Gaseous or Liquid Radioactivity to the Environment Greater Than 200 Times the ODCM for 15 Minutes or Longer. Pg. 6	Any Release of Gaseous or Liquid Radioactivity to the Environment Greater Than 2 Times the ODCM for 60 Minutes or Longer. Pg. 6	Unusual Event RU1 Nuclear or Destructive Phenomena Affecting the PROTECTED AREA. Pgs. 24	Unusual Event RU1 Nuclear or Destructive Phenomena Affecting the PROTECTED AREA. Pgs. 24
	Damage to irradiated Fuel or Loss of Fuel from the Unit or Irradiated Fuel Outside the Reactor Vessel. Pg. 8	Damage to irradiated Fuel or Loss of Fuel from the Unit or Irradiated Fuel Outside the Reactor Vessel. Pg. 8	Damage to irradiated Fuel or Loss of Fuel from the Unit or Irradiated Fuel Outside the Reactor Vessel. Pg. 8	UNPLANNED Rise in Plant Radiation Levels. Pg. 8	Alert HA1 Nuclear or Destructive Phenomena Affecting VITAL AREAS. Pgs. 24	Alert HA1 Nuclear or Destructive Phenomena Affecting VITAL AREAS. Pgs. 24
	Rise in Radiation Levels Within the Facility That Impedes Operation of Systems Required to Maintain Safe Plant Safety Functions. Pg. 8	Rise in Radiation Levels Within the Facility That Impedes Operation of Systems Required to Maintain Safe Plant Safety Functions. Pg. 8	Rise in Radiation Levels Within the Facility That Impedes Operation of Systems Required to Maintain Safe Plant Safety Functions. Pg. 8	RA3	Alert HA2 FIRE or EXPLOSION Affecting the Operability of Plant Safety Systems or Ability to Establish or Maintain Safe Shutdown. Pgs. 26	Alert HA2 FIRE or EXPLOSION Affecting the Operability of Plant Safety Systems or Ability to Establish or Maintain Safe Shutdown. Pgs. 26
	Loss of ANY Two Barriers AND Loss or Potential Loss of the third barrier. Pgs. 11-12	Loss of ANY Two Barriers AND Loss or Potential Loss of the third barrier. Pgs. 11-12	Loss of ANY Two Barriers AND Loss or Potential Loss of the third barrier. Pgs. 11-12	FA1	Alert HA3 Access to an VITAL AREA is Prohibited Due To Release of Toxic, Corrosive, Asphyxiant or Flammable Gases Which Require Systems Required to Maintain Safe Operation or Safety Shutdown the Reactor. Pgs. 26	Alert HA3 Access to an VITAL AREA is Prohibited Due To Release of Toxic, Corrosive, Asphyxiant or Flammable Gases Which Require Systems Required to Maintain Safe Operation or Safety Shutdown the Reactor. Pgs. 26
	Loss of ANY Two Barriers AND Loss or Potential Loss of the third barrier. Pgs. 11-12	Loss of ANY Two Barriers AND Loss or Potential Loss of the third barrier. Pgs. 11-12	Loss of ANY Two Barriers AND Loss or Potential Loss of the third barrier. Pgs. 11-12	FA1	Alert HA4 HOSTILE ACTION within the OWNER CONTROLLED AREA or Airborne Attack Threat. Pgs. 28	Alert HA4 HOSTILE ACTION within the OWNER CONTROLLED AREA or Airborne Attack Threat. Pgs. 28
	Prolonged Loss of All Off-site and All On-Site AC Power to Emergency Buses. Pg. 16	Loss of All Off-site and All On-site AC Power to Emergency Buses for 15 minutes or longer. Pg. 16	Loss of All Off-site and All On-site AC Power to Emergency Buses for 15 minutes or longer. Pg. 16	SA3	Alert HA5 Control Room Evacuation has been Initiated. Pgs. 28	Alert HA5 Control Room Evacuation has been Initiated. Pgs. 28
	Automatic Trip and All Manual Actions Fail to Shutdown the Reactor AND Indication of the Core Exits. Pg. 16	Automatic Trip and All Manual Actions Fail to Shutdown the Reactor AND Manual Actions Taken in the Control Room Successful in Shutting Down the Reactor. Pg. 16	Automatic Trip and All Manual Actions Taken in the Control Room Successful in Shutting Down the Reactor. Pg. 16	SA4	Alert HA6 Other Conditions Existing Which in the Judgment of the Emergency Coordinator Warrant Declaration of an Unusual Event (NOUJ). Pg. 30	Alert HA6 Other Conditions Existing Which in the Judgment of the Emergency Coordinator Warrant Declaration of an Unusual Event (NOUJ). Pg. 30
	Loss of All Vital DC Power for 15 Minutes or Longer. Pg. 16	Loss of All Vital DC Power for 15 Minutes or Longer. Pg. 16	Loss of All Vital DC Power for 15 Minutes or Longer. Pg. 16	SS3	Alert HA7 Control Room Evacuation has been Initiated and Plant Control Cannot be Established. Pgs. 28	Alert HA7 Control Room Evacuation has been Initiated and Plant Control Cannot be Established. Pgs. 28
	Inability to Monitor a Significant Transient in Progress. Pg. 16	Inability to Monitor a Significant Transient in Progress. Pg. 16	UNPLANNED Loss of Safety System Annunciation or Indication in the Control Room With Either (1) or (2) Compensatory Indications Unavailable. Pg. 18	SA4	Alert HA8 Other Conditions Existing Which in the Judgment of the Emergency Coordinator Warrant Declaration of an Unusual Event (NOUJ). Pg. 30	Alert HA8 Other Conditions Existing Which in the Judgment of the Emergency Coordinator Warrant Declaration of an Unusual Event (NOUJ). Pg. 30
			UNPLANNED Loss of Safety System Annunciation or Indication in the Control Room for 15 Minutes or Longer. Pg. 18	SU3	Alert HA9 Other Conditions Existing Which in the Judgment of the Emergency Coordinator Warrant Declaration of an Unusual Event (NOUJ). Pg. 30	Alert HA9 Other Conditions Existing Which in the Judgment of the Emergency Coordinator Warrant Declaration of an Unusual Event (NOUJ). Pg. 30
			RCS Leakage. Pg. 19	SU5	Alert HA10 Damage to a bonded cask confinement BOUNDARY. Pg. 34	Alert HA10 Damage to a bonded cask confinement BOUNDARY. Pg. 34
			Fuel Clad Degradation. Pg. 18	SU4	Alert HA11 Complete actions listed in EPIP-20101 Section 5.6	Alert HA11 Complete actions listed in EPIP-20101 Section 5.6
			Inability to Reach Required Shutdown Within Technical Specification Limits. Pg. 18	SU2	Alert HA12 Complete actions listed in EPIP-20101 Section 5.7	Alert HA12 Complete actions listed in EPIP-20101 Section 5.7
			Loss of All On-site or Off-site Communications Capabilities. Pg. 20	SU6	Alert HA13 Complete actions listed in EPIP-20101 Section 5.8	Alert HA13 Complete actions listed in EPIP-20101 Section 5.8

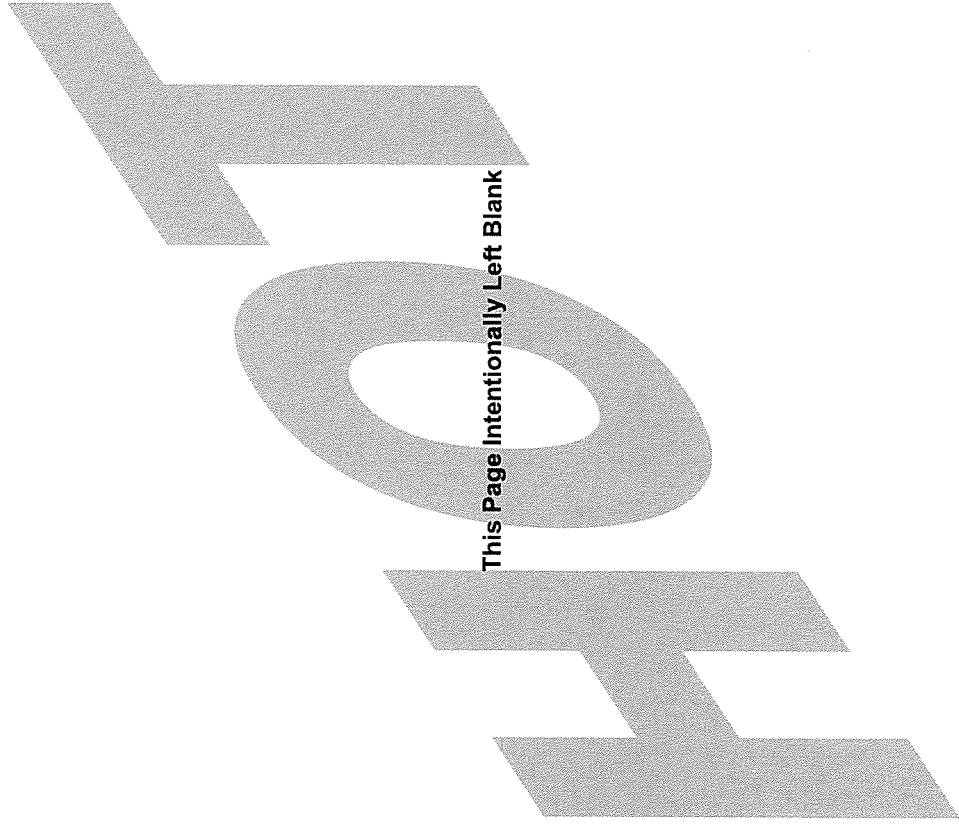

This Page Intentionally Left Blank

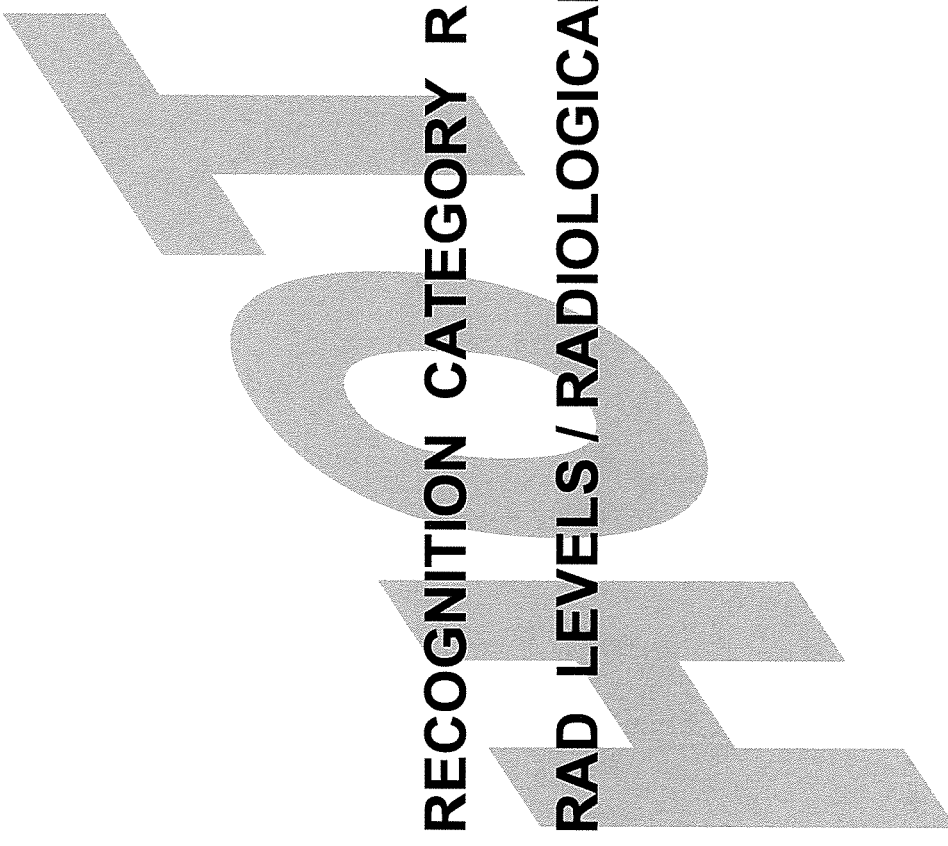

RECOGNITION CATEGORY R
ABNORMAL RAD LEVELS / RADIOLOGICAL EFFLUENT

Rec. Cat.	RG1 - Basis:	RS1 - Basis:	Site Area Emergency	Alert	Unusual Event
<p>This IC addresses radioactivity releases that result in doses at or beyond the site boundary that exceed the EPA Protective Action Guides (PAGs). Public protective actions will be necessary. Releases of this magnitude are associated with the failure of plant systems needed for the protection of the public and likely involve fuel damage.</p> <p><u>Threshold Values</u> The monitor list includes effluent monitors on all potential release pathways.</p> <p>Since dose assessment is based on actual meteorology, whereas the monitor reading Threshold is not, the results from these assessments may indicate that the classification is not warranted, or may indicate that a higher classification is warranted. For this reason, emergency implementing procedures call for the timely performance of dose assessments using actual meteorology and release information. If the results of these dose assessments are available when the classification is made (e.g., initiated at a lower classification level), the dose assessment results override the monitor reading EAL.</p>	<p>This IC addresses radioactivity releases that result in doses at or beyond the site boundary that exceed 10% of the EPA Protective Action Guides (PAGs). Releases of this magnitude are associated with the failure of plant systems needed for the protection of the public.</p> <p><u>Threshold Values</u> The monitor list in Threshold #1 includes effluent monitors on all potential release pathways.</p> <p>Since dose assessment is based on actual meteorology, whereas the monitor reading Threshold is not, the results from these assessments may indicate that the classification is not warranted, or may indicate that a higher classification is warranted. For this reason, emergency implementing procedures call for the timely performance of dose assessments using actual meteorology and release information. If the results of these dose assessments are available when the classification is made (e.g., initiated at a lower classification level), the dose assessment results override the monitor reading EAL.</p>	<p>The Emergency Coordinator should not wait until the applicable time has elapsed, but should declare the event as soon as it is determined that the condition will likely exceed the applicable time.</p> <p>This IC addresses an actual or substantial potential decrease in the level of safety of the plant as indicated by a radiological release that exceeds regulatory commitments for an extended period of time.</p> <p>Nuclear power plants incorporate features intended to control the release of radioactive effluents to the environment. Further, there are administrative controls established to prevent unintentional releases, or control and monitor intentional releases. These controls are located in the Off-site Dose Calculation Manual (ODCM). The occurrence of extended, uncontrolled radioactive releases to the environment is indicative of degradation in these features and/or controls.</p> <p>The ODCM multiples are specified in RU1 and RA1 only to distinguish between non-emergency conditions, and from each other. While these multiples obviously correspond to an off-site dose or dose rate, the emphasis in classifying these events is the degradation in the level of safety of the plant, not the magnitude of the associated dose or dose rate.</p> <p>Releases should not be prorated or averaged. For example, a release exceeding 4x ODCM for 30 minutes does not meet the threshold.</p> <p>This Threshold includes any release for which a radioactivity discharge permit was not prepared, or a release that exceeds the conditions (e.g., minimum dilution flow, maximum discharge flow, alarm setpoints, etc.) on the applicable permit.</p> <p><u>Threshold #1</u> This Threshold is intended for effluent monitoring on non-routine release pathways for which a discharge permit would not normally be prepared. The threshold values of this EAL are to be 200 times the ODCM limit or 100 times the threshold values used in RU1. This is true except for the thresholds given for the liquid release pathways: (PRMS-R-18 and PRMS-3/4/R-19). On both PRMS, the calculated values exceeded the range of the monitors. Therefore, the values used in the EAL are 95% of full scale. This lesser threshold is still indicative of a loss of control of radioactive material well in excess of that constituting an Unusual Event.</p> <p><u>Threshold #2</u> This Threshold addresses radioactivity releases, that for whatever reason, cause effluent radiation monitor readings to exceed the threshold identified in the IC established by the radioactivity discharge permit. This value may be associated with a planned batch release, or a continuous release path.</p> <p><u>Threshold #3</u> This Threshold addresses uncontrolled releases that are detected by sample analyses, particularly on unmonitored pathways, e.g., spills of radioactive liquids into storm drains, heat exchanger leakage in river water systems, etc.</p> <p>The underlying basis of this Threshold involves the degradation in the level of safety of the plant implied by the uncontrolled release.</p>	<p>The Emergency Coordinator should not wait until the applicable time has elapsed, but should declare the event as soon as it is determined that the condition will likely exceed the applicable time.</p> <p>This IC addresses a potential decrease in the level of safety of the plant as indicated by a radiological release that exceeds regulatory commitments for an extended period of time.</p> <p>Nuclear power plants incorporate features intended to control the release of radioactive effluents to the environment. Further, there are administrative controls established to prevent unintentional releases, or control and monitor intentional releases. These controls are located in the Off-site Dose Calculation Manual (ODCM). The occurrence of extended, uncontrolled radioactive releases to the environment is indicative of degradation in these features and/or controls.</p> <p>The ODCM multiples are specified in RU1 and RA1 only to distinguish between non-emergency conditions, and from each other. While these multiples obviously correspond to an off-site dose or dose rate, the emphasis in classifying these events is the degradation in the level of safety of the plant, not the magnitude of the associated dose or dose rate.</p> <p>Releases should not be prorated or averaged. For example, a release exceeding 4x ODCM for 30 minutes does not meet the threshold.</p> <p>This Threshold includes any release for which a radioactivity discharge permit was not prepared, or a release that exceeds the conditions (e.g., minimum dilution flow, maximum discharge flow, alarm setpoints, etc.) on the applicable permit.</p> <p><u>Threshold #1</u> This Threshold addresses radioactivity releases, that for whatever reason, cause effluent radiation monitor readings to exceed the threshold identified in the IC.</p> <p>This Threshold is intended for sites that have established effluent monitoring on non-routine release pathways for which a discharge permit would not normally be prepared.</p> <p><u>Threshold #2</u> This Threshold addresses radioactivity releases, that for whatever reason, cause effluent radiation monitor readings to exceed the threshold identified in the IC established by the radioactivity discharge permit. This value may be associated with a planned batch release, or a continuous release path.</p> <p><u>Threshold #3</u> This Threshold addresses uncontrolled releases that are detected by sample analyses, particularly on unmonitored pathways, e.g., spills of radioactive liquids into storm drains, heat exchanger leakage in river water systems, etc.</p> <p>The underlying basis of this Threshold involves the degradation in the level of safety of the plant implied by the uncontrolled release.</p>		

R - ABNORMAL RAD LEVELS/RADIOLOGICAL EFFLUENT

R – ABNORMAL RAD LEVELS/RADIOLOGICAL EFFLUENT		Recognition Category																																																																																																																																																																							
RADIOLOGICAL EFFLUENT																																																																																																																																																																									
<p>RG1 Off-site Dose Resulting from an Actual or IMMINENT Release of Gaseous Radioactivity Greater Than 1000 mRem TEDE or 5000 mRem Thyroid CDE for the Actual or Projected Duration of the Release Using Actual Meteorology.</p> <p>Operating Mode Applicability: All</p> <p>Threshold Values:</p> <p><i>Note:</i> The Emergency Coordinator should not wait until the applicable time has elapsed, but should declare the event as soon as it is determined that the condition will likely exceed the applicable time. If the condition is not likely to exceed the applicable time, the assessment should be based on dose assessment instead of radiation monitor values. Do not delay declaration awaiting dose assessment results.</p> <p>1. VALID reading on ANY of the following radiation monitors greater than the value shown for 15 minutes or longer:</p> <table border="1"> <thead> <tr> <th>Monitor</th> <th>Pathway</th> <th>Value</th> </tr> </thead> <tbody> <tr> <td>RAD-6304</td> <td>Plant Vent SPING</td> <td>3.0E+0 uCi/cc</td> </tr> <tr> <td>RAD 6418</td> <td>Unit 4 Via Plant Vent SPING</td> <td>1.2E+1 uCi/cc</td> </tr> <tr> <td>RAD 6426 (DAM-1)</td> <td>Main Steam Line Monitor</td> <td>2.6E+2 uCi/cc</td> </tr> <tr> <td>RAD-3141-6417</td> <td>SJAE SPING</td> <td>8.0E+3 uCi/cc</td> </tr> </tbody> </table> <p>OR</p> <p>Dose assessment using actual meteorology indicates doses greater than 1000 mRem TEDE or 5000 mRem Thyroid CDE at or beyond the site boundary.</p> <p>OR</p> <p>Field survey results indicate closed window dose rates greater than 1000 mRem TEDE or 5000 mRem Thyroid CDE (greater than 5000 mRem for one hour of inhalation, at or beyond site boundary).</p> <p>GUIDANCE BOX FOR USE OF SPING MONITORS IN RADIOLOGICAL EFFLUENT TABLES</p> <p>The calculations for the SPING monitors listed are based on NOBLE GAS levels; use SPING channels 5, 7, and 9 as appropriate for the indicated values in the tables. (Ref: DBD PTN-NEI-99-01)</p> <table border="1"> <thead> <tr> <th>Channel</th> <th>Range</th> <th>Typical Reading</th> </tr> </thead> <tbody> <tr> <td>Ch-5</td> <td>Low Range</td> <td>1.0E-07 - 6.0E-02</td> </tr> <tr> <td>Ch-7</td> <td>Mid Range</td> <td>2.5E-02 - 4.0E+02</td> </tr> <tr> <td>Ch-9</td> <td>High Range</td> <td>1.0E+00 - 1.0E+05</td> </tr> </tbody> </table> <p>DEFINITION BOX</p> <p>IMMINENT – Mitigation actions have been ineffective, additional actions are not expected to be successful, and trended information indicates that the event or condition will occur. Where IMMINENT lineframes are specified, they shall apply.</p> <p>VALID – An indication, report, or condition, is considered to be VALID when it is verified by (1) an instrument channel check, (2) indications on period or redundant indicators, or (3) by direct observation by plant personnel, such that doubt related to the indicator's operability, the accuracy of the data, or the emergency is removed. Implicit in this definition is the need for timely assessment.</p>	Monitor	Pathway	Value	RAD-6304	Plant Vent SPING	3.0E+0 uCi/cc	RAD 6418	Unit 4 Via Plant Vent SPING	1.2E+1 uCi/cc	RAD 6426 (DAM-1)	Main Steam Line Monitor	2.6E+2 uCi/cc	RAD-3141-6417	SJAE SPING	8.0E+3 uCi/cc	Channel	Range	Typical Reading	Ch-5	Low Range	1.0E-07 - 6.0E-02	Ch-7	Mid Range	2.5E-02 - 4.0E+02	Ch-9	High Range	1.0E+00 - 1.0E+05	<p>RA1 Any Release of Gaseous or Liquid Radioactivity to the Environment Greater Than 200 Times the ODCM for 15 Minutes or Longer.</p> <p>Operating Mode Applicability: All</p> <p>Threshold Values:</p> <p><i>Note:</i> The Emergency Coordinator should not wait until the applicable time has elapsed, but should declare the event as soon as it is determined that the release duration has exceeded, or will likely exceed, the applicable time. In the absence of data to the contrary, assume that the release duration has exceeded the applicable time if an ongoing release is detected and the release start time is unknown.</p> <p>1. VALID reading on ANY of the following radiation monitors greater than the value shown for 15 minutes or longer:</p> <table border="1"> <thead> <tr> <th>Monitor</th> <th>Pathway</th> <th>Value</th> </tr> </thead> <tbody> <tr> <td>RAD-6304</td> <td>Plant Vent SPING</td> <td>3.4E-2 uCi/cc</td> </tr> <tr> <td>RAD 6418</td> <td>Unit 4 Via Plant Vent SPING</td> <td>1.4E-1 uCi/cc</td> </tr> <tr> <td>RAD 6426 (DAM-1)</td> <td>N/A</td> <td>N/A</td> </tr> <tr> <td>RAD-3141-6417</td> <td>SJAE SPING</td> <td>9.1E+1 uCi/cc</td> </tr> <tr> <td>PRMS R-18</td> <td>Liquid Rad Waste Effluent Line</td> <td>2.4E+5 cpm</td> </tr> <tr> <td>PRMS-3141-R-19</td> <td>Any one Steam Generator Blowdown</td> <td>2.4E+5 cpm</td> </tr> </tbody> </table> <p>OR</p> <p>VALID reading on any effluent monitor reading that greater than 200 times the alarm setpoint established by a current radioactively discharge permit for 15 minutes or longer.</p> <p>OR</p> <p>Confirmed sample analyses for gaseous or liquid releases indicates concentrations or release rates greater than 200 times ODCM limits for 15 minutes or longer.</p> <p>GUIDANCE BOX FOR USE OF SPING MONITORS IN RADIOLOGICAL EFFLUENT TABLES</p> <p>The calculations for the SPING monitors listed are based on NOBLE GAS levels; use SPING channels 5, 7, and 9 as appropriate for the indicated values in the tables. (Ref: DBD PTN-NEI-99-01)</p> <table border="1"> <thead> <tr> <th>Channel</th> <th>Range</th> <th>Typical Reading</th> </tr> </thead> <tbody> <tr> <td>Ch-5</td> <td>Low Range</td> <td>1.0E-07 - 6.0E-02</td> </tr> <tr> <td>Ch-7</td> <td>Mid Range</td> <td>2.5E-02 - 4.0E+02</td> </tr> <tr> <td>Ch-9</td> <td>High Range</td> <td>1.0E+00 - 1.0E+05</td> </tr> </tbody> </table>	Monitor	Pathway	Value	RAD-6304	Plant Vent SPING	3.4E-2 uCi/cc	RAD 6418	Unit 4 Via Plant Vent SPING	1.4E-1 uCi/cc	RAD 6426 (DAM-1)	N/A	N/A	RAD-3141-6417	SJAE SPING	9.1E+1 uCi/cc	PRMS R-18	Liquid Rad Waste Effluent Line	2.4E+5 cpm	PRMS-3141-R-19	Any one Steam Generator Blowdown	2.4E+5 cpm	Channel	Range	Typical Reading	Ch-5	Low Range	1.0E-07 - 6.0E-02	Ch-7	Mid Range	2.5E-02 - 4.0E+02	Ch-9	High Range	1.0E+00 - 1.0E+05	<p>RA1 Any Release of Gaseous or Liquid Radioactivity to the Environment Greater Than 200 Times the ODCM for 15 Minutes or Longer.</p> <p>Operating Mode Applicability: All</p> <p>Threshold Values:</p> <p><i>Note:</i> The Emergency Coordinator should not wait until the applicable time has elapsed, but should declare the event as soon as it is determined that the release duration has exceeded, or will likely exceed, the applicable time. In the absence of data to the contrary, assume that the release duration has exceeded the applicable time if an ongoing release is detected and the release start time is unknown.</p> <p>1. VALID reading on ANY of the following radiation monitors greater than the value shown for 15 minutes or longer:</p> <table border="1"> <thead> <tr> <th>Monitor</th> <th>Pathway</th> <th>Value</th> </tr> </thead> <tbody> <tr> <td>RAD-6304</td> <td>Plant Vent SPING</td> <td>3.4E-2 uCi/cc</td> </tr> <tr> <td>RAD 6418</td> <td>Unit 4 Via Plant Vent SPING</td> <td>1.4E-1 uCi/cc</td> </tr> <tr> <td>RAD 6426 (DAM-1)</td> <td>Main Steam Line Monitor</td> <td>2.9E+0 uCi/cc</td> </tr> <tr> <td>RAD-3141-6417</td> <td>SJAE SPING</td> <td>9.1E+1 uCi/cc</td> </tr> <tr> <td>PRMS R-18</td> <td>Liquid Rad Waste Effluent Line</td> <td>2.4E+5 cpm</td> </tr> <tr> <td>PRMS-3141-R-19</td> <td>Any one Steam Generator Blowdown</td> <td>2.4E+5 cpm</td> </tr> </tbody> </table> <p>OR</p> <p>VALID reading on any effluent monitor reading that greater than 200 times the alarm setpoint established by a current radioactively discharge permit for 15 minutes or longer.</p> <p>OR</p> <p>Confirmed sample analyses for gaseous or liquid releases indicates concentrations or release rates greater than 200 times ODCM limits for 15 minutes or longer.</p> <p>GUIDANCE BOX FOR USE OF SPING MONITORS IN RADIOLOGICAL EFFLUENT TABLES</p> <p>The calculations for the SPING monitors listed are based on NOBLE GAS levels; use SPING channels 5, 7, and 9 as appropriate for the indicated values in the tables. (Ref: DBD PTN-NEI-99-01)</p> <table border="1"> <thead> <tr> <th>Channel</th> <th>Range</th> <th>Typical Reading</th> </tr> </thead> <tbody> <tr> <td>Ch-5</td> <td>Low Range</td> <td>1.0E-07 - 6.0E-02</td> </tr> <tr> <td>Ch-7</td> <td>Mid Range</td> <td>2.5E-02 - 4.0E+02</td> </tr> <tr> <td>Ch-9</td> <td>High Range</td> <td>1.0E+00 - 1.0E+05</td> </tr> </tbody> </table>	Monitor	Pathway	Value	RAD-6304	Plant Vent SPING	3.4E-2 uCi/cc	RAD 6418	Unit 4 Via Plant Vent SPING	1.4E-1 uCi/cc	RAD 6426 (DAM-1)	Main Steam Line Monitor	2.9E+0 uCi/cc	RAD-3141-6417	SJAE SPING	9.1E+1 uCi/cc	PRMS R-18	Liquid Rad Waste Effluent Line	2.4E+5 cpm	PRMS-3141-R-19	Any one Steam Generator Blowdown	2.4E+5 cpm	Channel	Range	Typical Reading	Ch-5	Low Range	1.0E-07 - 6.0E-02	Ch-7	Mid Range	2.5E-02 - 4.0E+02	Ch-9	High Range	1.0E+00 - 1.0E+05	<p>RU1 Any Release of Gaseous or Liquid Radioactivity to the Environment Greater Than 2 Times the ODCM for 60 Minutes or Longer.</p> <p>Operating Mode Applicability: All</p> <p>Threshold Values:</p> <p><i>Note:</i> The Emergency Coordinator should not wait until the applicable time has elapsed, but should declare the event as soon as it is determined that the release duration has exceeded, or will likely exceed, the applicable time. In the absence of data to the contrary, assume that the release duration has exceeded the applicable time if an ongoing release is detected and the release start time is unknown.</p> <p>1. VALID reading on ANY of the following radiation monitors greater than the value shown for 60 minutes or longer:</p> <table border="1"> <thead> <tr> <th>Monitor</th> <th>Pathway</th> <th>Value</th> </tr> </thead> <tbody> <tr> <td>RAD-6304</td> <td>Plant Vent SPING</td> <td>3.4E-4 uCi/cc</td> </tr> <tr> <td>RAD 6418</td> <td>Unit 4 Via Plant Vent SPING</td> <td>1.4E-3 uCi/cc</td> </tr> <tr> <td>RAD 6426 (DAM-1)</td> <td>N/A</td> <td>N/A</td> </tr> <tr> <td>RAD-3141-6417</td> <td>SJAE SPING</td> <td>9.1E-1 uCi/cc</td> </tr> <tr> <td>PRMS R-18</td> <td>Liquid Rad Waste Effluent Line</td> <td>1.6E+4 cpm</td> </tr> <tr> <td>PRMS-3141-R-19</td> <td>Any one Steam Generator Blowdown</td> <td>1.6E+4 cpm</td> </tr> <tr> <td>PRMS R-14</td> <td>Plant Vent (PV)</td> <td>6.8E+4 cpm</td> </tr> </tbody> </table> <p>OR</p> <p>VALID reading on any effluent monitor reading greater than 2 times the alarm setpoint established by a current radioactively discharge permit for 60 minutes or longer.</p> <p>OR</p> <p>Confirmed sample analyses for gaseous or liquid releases indicates concentrations or release rates greater than 2 times ODCM limits for 60 minutes or longer.</p> <p>GUIDANCE BOX FOR USE OF SPING MONITORS IN RADIOLOGICAL EFFLUENT TABLES</p> <p>The calculations for the SPING monitors listed are based on NOBLE GAS levels; use SPING channels 5, 7, and 9 as appropriate for the indicated values in the tables. (Ref: DBD PTN-NEI-99-01)</p> <table border="1"> <thead> <tr> <th>Channel</th> <th>Range</th> <th>Typical Reading</th> </tr> </thead> <tbody> <tr> <td>Ch-5</td> <td>Low Range</td> <td>1.0E-07 - 6.0E-02</td> </tr> <tr> <td>Ch-7</td> <td>Mid Range</td> <td>2.5E-02 - 4.0E+02</td> </tr> <tr> <td>Ch-9</td> <td>High Range</td> <td>1.0E+00 - 1.0E+05</td> </tr> </tbody> </table>	Monitor	Pathway	Value	RAD-6304	Plant Vent SPING	3.4E-4 uCi/cc	RAD 6418	Unit 4 Via Plant Vent SPING	1.4E-3 uCi/cc	RAD 6426 (DAM-1)	N/A	N/A	RAD-3141-6417	SJAE SPING	9.1E-1 uCi/cc	PRMS R-18	Liquid Rad Waste Effluent Line	1.6E+4 cpm	PRMS-3141-R-19	Any one Steam Generator Blowdown	1.6E+4 cpm	PRMS R-14	Plant Vent (PV)	6.8E+4 cpm	Channel	Range	Typical Reading	Ch-5	Low Range	1.0E-07 - 6.0E-02	Ch-7	Mid Range	2.5E-02 - 4.0E+02	Ch-9	High Range	1.0E+00 - 1.0E+05	<p>Unusual Event</p> <p>RU1 Any Release of Gaseous or Liquid Radioactivity to the Environment Greater Than 2 Times the ODCM for 60 Minutes or Longer.</p> <p>Operating Mode Applicability: All</p> <p>Threshold Values:</p> <p><i>Note:</i> The Emergency Coordinator should not wait until the applicable time has elapsed, but should declare the event as soon as it is determined that the release duration has exceeded, or will likely exceed, the applicable time. In the absence of data to the contrary, assume that the release duration has exceeded the applicable time if an ongoing release is detected and the release start time is unknown.</p> <p>1. VALID reading on ANY of the following radiation monitors greater than the value shown for 60 minutes or longer:</p> <table border="1"> <thead> <tr> <th>Monitor</th> <th>Pathway</th> <th>Value</th> </tr> </thead> <tbody> <tr> <td>RAD-6304</td> <td>Plant Vent SPING</td> <td>3.4E-4 uCi/cc</td> </tr> <tr> <td>RAD 6418</td> <td>Unit 4 Via Plant Vent SPING</td> <td>1.4E-3 uCi/cc</td> </tr> <tr> <td>RAD 6426 (DAM-1)</td> <td>N/A</td> <td>N/A</td> </tr> <tr> <td>RAD-3141-6417</td> <td>SJAE SPING</td> <td>9.1E-1 uCi/cc</td> </tr> <tr> <td>PRMS R-18</td> <td>Liquid Rad Waste Effluent Line</td> <td>1.6E+4 cpm</td> </tr> <tr> <td>PRMS-3141-R-19</td> <td>Any one Steam Generator Blowdown</td> <td>1.6E+4 cpm</td> </tr> <tr> <td>PRMS R-14</td> <td>Plant Vent (PV)</td> <td>6.8E+4 cpm</td> </tr> </tbody> </table> <p>OR</p> <p>VALID reading on any effluent monitor reading greater than 2 times the alarm setpoint established by a current radioactively discharge permit for 60 minutes or longer.</p> <p>OR</p> <p>Confirmed sample analyses for gaseous or liquid releases indicates concentrations or release rates greater than 2 times ODCM limits for 60 minutes or longer.</p> <p>GUIDANCE BOX FOR USE OF SPING MONITORS IN RADIOLOGICAL EFFLUENT TABLES</p> <p>The calculations for the SPING monitors listed are based on NOBLE GAS levels; use SPING channels 5, 7, and 9 as appropriate for the indicated values in the tables. (Ref: DBD PTN-NEI-99-01)</p> <table border="1"> <thead> <tr> <th>Channel</th> <th>Range</th> <th>Typical Reading</th> </tr> </thead> <tbody> <tr> <td>Ch-5</td> <td>Low Range</td> <td>1.0E-07 - 6.0E-02</td> </tr> <tr> <td>Ch-7</td> <td>Mid Range</td> <td>2.5E-02 - 4.0E+02</td> </tr> <tr> <td>Ch-9</td> <td>High Range</td> <td>1.0E+00 - 1.0E+05</td> </tr> </tbody> </table>	Monitor	Pathway	Value	RAD-6304	Plant Vent SPING	3.4E-4 uCi/cc	RAD 6418	Unit 4 Via Plant Vent SPING	1.4E-3 uCi/cc	RAD 6426 (DAM-1)	N/A	N/A	RAD-3141-6417	SJAE SPING	9.1E-1 uCi/cc	PRMS R-18	Liquid Rad Waste Effluent Line	1.6E+4 cpm	PRMS-3141-R-19	Any one Steam Generator Blowdown	1.6E+4 cpm	PRMS R-14	Plant Vent (PV)	6.8E+4 cpm	Channel	Range	Typical Reading	Ch-5	Low Range	1.0E-07 - 6.0E-02	Ch-7	Mid Range	2.5E-02 - 4.0E+02	Ch-9	High Range	1.0E+00 - 1.0E+05
Monitor	Pathway	Value																																																																																																																																																																							
RAD-6304	Plant Vent SPING	3.0E+0 uCi/cc																																																																																																																																																																							
RAD 6418	Unit 4 Via Plant Vent SPING	1.2E+1 uCi/cc																																																																																																																																																																							
RAD 6426 (DAM-1)	Main Steam Line Monitor	2.6E+2 uCi/cc																																																																																																																																																																							
RAD-3141-6417	SJAE SPING	8.0E+3 uCi/cc																																																																																																																																																																							
Channel	Range	Typical Reading																																																																																																																																																																							
Ch-5	Low Range	1.0E-07 - 6.0E-02																																																																																																																																																																							
Ch-7	Mid Range	2.5E-02 - 4.0E+02																																																																																																																																																																							
Ch-9	High Range	1.0E+00 - 1.0E+05																																																																																																																																																																							
Monitor	Pathway	Value																																																																																																																																																																							
RAD-6304	Plant Vent SPING	3.4E-2 uCi/cc																																																																																																																																																																							
RAD 6418	Unit 4 Via Plant Vent SPING	1.4E-1 uCi/cc																																																																																																																																																																							
RAD 6426 (DAM-1)	N/A	N/A																																																																																																																																																																							
RAD-3141-6417	SJAE SPING	9.1E+1 uCi/cc																																																																																																																																																																							
PRMS R-18	Liquid Rad Waste Effluent Line	2.4E+5 cpm																																																																																																																																																																							
PRMS-3141-R-19	Any one Steam Generator Blowdown	2.4E+5 cpm																																																																																																																																																																							
Channel	Range	Typical Reading																																																																																																																																																																							
Ch-5	Low Range	1.0E-07 - 6.0E-02																																																																																																																																																																							
Ch-7	Mid Range	2.5E-02 - 4.0E+02																																																																																																																																																																							
Ch-9	High Range	1.0E+00 - 1.0E+05																																																																																																																																																																							
Monitor	Pathway	Value																																																																																																																																																																							
RAD-6304	Plant Vent SPING	3.4E-2 uCi/cc																																																																																																																																																																							
RAD 6418	Unit 4 Via Plant Vent SPING	1.4E-1 uCi/cc																																																																																																																																																																							
RAD 6426 (DAM-1)	Main Steam Line Monitor	2.9E+0 uCi/cc																																																																																																																																																																							
RAD-3141-6417	SJAE SPING	9.1E+1 uCi/cc																																																																																																																																																																							
PRMS R-18	Liquid Rad Waste Effluent Line	2.4E+5 cpm																																																																																																																																																																							
PRMS-3141-R-19	Any one Steam Generator Blowdown	2.4E+5 cpm																																																																																																																																																																							
Channel	Range	Typical Reading																																																																																																																																																																							
Ch-5	Low Range	1.0E-07 - 6.0E-02																																																																																																																																																																							
Ch-7	Mid Range	2.5E-02 - 4.0E+02																																																																																																																																																																							
Ch-9	High Range	1.0E+00 - 1.0E+05																																																																																																																																																																							
Monitor	Pathway	Value																																																																																																																																																																							
RAD-6304	Plant Vent SPING	3.4E-4 uCi/cc																																																																																																																																																																							
RAD 6418	Unit 4 Via Plant Vent SPING	1.4E-3 uCi/cc																																																																																																																																																																							
RAD 6426 (DAM-1)	N/A	N/A																																																																																																																																																																							
RAD-3141-6417	SJAE SPING	9.1E-1 uCi/cc																																																																																																																																																																							
PRMS R-18	Liquid Rad Waste Effluent Line	1.6E+4 cpm																																																																																																																																																																							
PRMS-3141-R-19	Any one Steam Generator Blowdown	1.6E+4 cpm																																																																																																																																																																							
PRMS R-14	Plant Vent (PV)	6.8E+4 cpm																																																																																																																																																																							
Channel	Range	Typical Reading																																																																																																																																																																							
Ch-5	Low Range	1.0E-07 - 6.0E-02																																																																																																																																																																							
Ch-7	Mid Range	2.5E-02 - 4.0E+02																																																																																																																																																																							
Ch-9	High Range	1.0E+00 - 1.0E+05																																																																																																																																																																							
Monitor	Pathway	Value																																																																																																																																																																							
RAD-6304	Plant Vent SPING	3.4E-4 uCi/cc																																																																																																																																																																							
RAD 6418	Unit 4 Via Plant Vent SPING	1.4E-3 uCi/cc																																																																																																																																																																							
RAD 6426 (DAM-1)	N/A	N/A																																																																																																																																																																							
RAD-3141-6417	SJAE SPING	9.1E-1 uCi/cc																																																																																																																																																																							
PRMS R-18	Liquid Rad Waste Effluent Line	1.6E+4 cpm																																																																																																																																																																							
PRMS-3141-R-19	Any one Steam Generator Blowdown	1.6E+4 cpm																																																																																																																																																																							
PRMS R-14	Plant Vent (PV)	6.8E+4 cpm																																																																																																																																																																							
Channel	Range	Typical Reading																																																																																																																																																																							
Ch-5	Low Range	1.0E-07 - 6.0E-02																																																																																																																																																																							
Ch-7	Mid Range	2.5E-02 - 4.0E+02																																																																																																																																																																							
Ch-9	High Range	1.0E+00 - 1.0E+05																																																																																																																																																																							
TURKEY POINT EAL CLASSIFICATION TABLES																																																																																																																																																																									
ATTACHMENT 1 - F-668 - Rev 3 (EPIP-20101)																																																																																																																																																																									
HOT CONDITIONS 6																																																																																																																																																																									

R - ABNORMAL RAD LEVELS/RADIOLOGICAL EFFLUENT

RA2 - Basis:

This IC addresses increases in radiation dose rates within plant buildings, and may be a precursor to a radioactivity release to the environment. These events represent a loss of control over radioactive material and represent an actual or substantial potential degradation in the level of safety of the plant.

Threshold #1

A specific value is not specified in that the elevation of any fuel bundle in transit must be considered for evaluating this condition.

Threshold #2

This Threshold addresses radiation monitor indications of fuel uncover and/or fuel damage.

Increased ventilation monitor readings may be indication of a radioactivity release from the fuel, confirming that damage has occurred. Increased background at the ventilation monitor due to water level decrease may mask increased ventilation exhaust airborne activity and needs to be considered.

While a radiation monitor could detect an increase in dose rate due to a drop in the water level, it might not be a reliable indication of whether or not the fuel is covered.

Escalation of this emergency classification level, if appropriate, would be based on RS1 or RG1.

RA3 - Basis:

This IC addresses increased radiation levels that impact continued operation in areas requiring continuous occupancy to maintain safe operation or to perform a safe shutdown.

The cause and/or magnitude of the increase in radiation levels is not a concern of this IC. The Emergency Coordinator must consider the source or cause of the increased radiation levels and determine if any other IC may be involved.

Areas requiring continuous occupancy are the Control Room and CAS

The value of 15 mR/hr is derived from the GDC 19 value of 5 rem in 30 days with adjustment for expected occupancy times. Although Section III.D.3 of NUREG-0737, "Clarification of TMI Action Plan Requirements", provides that the 15 mR/hr value can be averaged over the 30 day, the value is used here without averaging, as a 30 day duration implies an event potentially more significant than an Alert.

RU2 - Basis:

This IC addresses increased radiation levels as a result of water level decreases above irradiated fuel or events that have resulted, or may result, in UNPLANNED increases in radiation dose rates within plant buildings. These radiation increases represent a loss of control over radioactive material and represent a potential degradation in the level of safety of the plant.

Threshold #1

The refueling pathway is the combination of the refueling cavity, transfer canal, and spent fuel pool. While a radiation monitor could detect an increase in dose rate due to a drop in the water level, it might not be a reliable indication of whether or not the fuel is covered.

For refueling events where the water level drops below the RPV flange classification would be via CU2. This event escalates to an Alert per RA2 if irradiated fuel outside the reactor vessel is uncovered. For events involving irradiated fuel in the reactor vessel, escalation would be via the Fission Product Barrier Table for events in operating modes 1-4.

Threshold #2

This Threshold addresses increases in plant radiation levels that represent a loss of control of radioactive material resulting in a potential degradation in the level of safety of the plant.

This Threshold excludes radiation level increases that result from planned activities such as use of radiographic sources and movement of radioactive waste materials. A specific list of ARMs is not required as it would restrict the applicability of the Threshold. The intent is to identify loss of control of radioactive material in any monitored area.

This event escalates to an Alert per RA3 if the increase in dose rates impedes personnel access necessary for safe operation.

GUIDANCE BOX FOR USE OF TEMPORARY MONITORS IN ABNORMAL RADIATION TABLES

Portable radiation monitors staged as compensatory actions for OOS monitors may be used in place of installed equipment, only if data is available to the Control Room, for the purpose of this EAL.

Site Area Emergency	Alert	Unusual Event	Recognition Category																
<p>DEFINITION BOX</p> <p>UNPLANNED – A parameter change or an event that is not the result of an intended evolution and requires corrective or mitigative actions.</p> <p>VALID – An indication, report, or condition, is considered to be VALID when it is verified by (1) an instrument channel check, (2) indications on related or redundant indicators, or (3) by direct observation by plant personnel, such that doubt related to the indicator's operability, the condition's existence, or the report's accuracy is removed. Implicit in this definition is the need for timely assessment.</p>	<p>RA2 Damage to irradiated fuel or Loss of Water Level that Has Resulted or Will Result in the Uncovering of Irradiated Fuel Outside the Reactor Vessel.</p> <p>Operating Mode Applicability: All</p> <p>Threshold Values:</p> <ol style="list-style-type: none"> A water level drop in the reactor refueling cavity, spent fuel pool or fuel transfer canal that will result in irradiated fuel becoming uncovered. <p>OR</p> <ol style="list-style-type: none"> A VALID elevated reading of greater than or equal to 1.0 E+4 mR/hr on ANY of the following due to damage to irradiated fuel or loss of water level: <table border="1" data-bbox="479 346 649 882"> <thead> <tr> <th>Unit 3</th> <th>Unit 4</th> </tr> </thead> <tbody> <tr> <td>RI-3-1402B, UNIT 3 CONTAINMENT OPERATING FLOOR</td> <td>RI-4-1405B, UNIT 4 CONTAINMENT OPERATING FLOOR</td> </tr> <tr> <td>RI-3-1407B, UNIT 3 SPENT FUEL PIT CANAL AREA</td> <td>RI-4-1408B, UNIT 4 SPENT FUEL PIT CANAL AREA</td> </tr> <tr> <td>RI-3-1421B, UNIT 3 SPENT FUEL PIT NORTH WALL</td> <td>RI-4-1422B, UNIT 4 SPENT FUEL PIT SOUTH WALL</td> </tr> </tbody> </table>	Unit 3	Unit 4	RI-3-1402B, UNIT 3 CONTAINMENT OPERATING FLOOR	RI-4-1405B, UNIT 4 CONTAINMENT OPERATING FLOOR	RI-3-1407B, UNIT 3 SPENT FUEL PIT CANAL AREA	RI-4-1408B, UNIT 4 SPENT FUEL PIT CANAL AREA	RI-3-1421B, UNIT 3 SPENT FUEL PIT NORTH WALL	RI-4-1422B, UNIT 4 SPENT FUEL PIT SOUTH WALL	<p>RA3 Rise in Radiation Levels Within the Facility That Impedes Operation of Systems Required to Maintain Safe Plant Safety Functions.</p> <p>Operating Mode Applicability: All</p> <p>Threshold Values:</p> <ol style="list-style-type: none"> Dose rate greater than 15 mR/hr in ANY of the following areas requiring continuous occupancy to maintain plant safety functions: <ul style="list-style-type: none"> Control Room CAS 	<p>R – ABNORMAL RAD LEVELS/RADIOLOGICAL EFFLUENT</p> <p>ABNORMAL RAD LEVELS</p> <p>RU2 UNPLANNED Rise in Plant Radiation Levels.</p> <p>Operating Mode Applicability: All</p> <p>Threshold Values:</p> <ol style="list-style-type: none"> UNPLANNED water level drop in a reactor refueling pathway as indicated by L1-3(f)-651 56 10 (8FP LO LEVEL Alarm). <p>AND</p> <p>VALID Area Radiation Monitor reading rise on any of the following:</p> <table border="1" data-bbox="820 346 974 882"> <thead> <tr> <th>Unit 3</th> <th>Unit 4</th> </tr> </thead> <tbody> <tr> <td>RI-3-1402B, UNIT 3 CONTAINMENT OPERATING FLOOR</td> <td>RI-4-1405B, UNIT 4 CONTAINMENT OPERATING FLOOR</td> </tr> <tr> <td>RI-3-1407B, UNIT 3 SPENT FUEL PIT CANAL AREA</td> <td>RI-4-1408B, UNIT 4 SPENT FUEL PIT CANAL AREA</td> </tr> <tr> <td>RI-3-1421B, UNIT 3 SPENT FUEL PIT NORTH WALL</td> <td>RI-4-1422B, UNIT 4 SPENT FUEL PIT SOUTH WALL</td> </tr> </tbody> </table> <p>OR</p> <ol style="list-style-type: none"> UNPLANNED VALID Area Radiation Monitor readings or survey results indicate a rise by a factor of 1000 over normal levels. Normal can be considered as the highest reading in the past twenty-four hours excluding the current peak value. <p>GUIDANCE BOX FOR RU2, Threshold 1</p> <p>This event addresses increased radiation levels as a result of decreasing water level above irradiated fuel. Spent Fuel Pool low level alarms resulting from routine evaporation accompanied by normal and expected area radiation levels are not subject to this EAL.</p> <p>GUIDANCE BOX FOR USE OF MONITORS IN ABNORMAL RADIATION TABLES</p> <p>Area Radiation monitors in the Control Room indicate in mR/hr up to 100 mR/hr. Monitors automatically switch to Renfhr as noted at the monitor.</p> <p>GUIDANCE BOX FOR USE OF TEMPORARY MONITORS IN ABNORMAL RADIATION TABLES</p> <p>Portable radiation monitors staged as compensatory actions for OOS monitors should be used in place of installed equipment for the purpose of this EAL.</p>	Unit 3	Unit 4	RI-3-1402B, UNIT 3 CONTAINMENT OPERATING FLOOR	RI-4-1405B, UNIT 4 CONTAINMENT OPERATING FLOOR	RI-3-1407B, UNIT 3 SPENT FUEL PIT CANAL AREA	RI-4-1408B, UNIT 4 SPENT FUEL PIT CANAL AREA	RI-3-1421B, UNIT 3 SPENT FUEL PIT NORTH WALL	RI-4-1422B, UNIT 4 SPENT FUEL PIT SOUTH WALL
Unit 3	Unit 4																		
RI-3-1402B, UNIT 3 CONTAINMENT OPERATING FLOOR	RI-4-1405B, UNIT 4 CONTAINMENT OPERATING FLOOR																		
RI-3-1407B, UNIT 3 SPENT FUEL PIT CANAL AREA	RI-4-1408B, UNIT 4 SPENT FUEL PIT CANAL AREA																		
RI-3-1421B, UNIT 3 SPENT FUEL PIT NORTH WALL	RI-4-1422B, UNIT 4 SPENT FUEL PIT SOUTH WALL																		
Unit 3	Unit 4																		
RI-3-1402B, UNIT 3 CONTAINMENT OPERATING FLOOR	RI-4-1405B, UNIT 4 CONTAINMENT OPERATING FLOOR																		
RI-3-1407B, UNIT 3 SPENT FUEL PIT CANAL AREA	RI-4-1408B, UNIT 4 SPENT FUEL PIT CANAL AREA																		
RI-3-1421B, UNIT 3 SPENT FUEL PIT NORTH WALL	RI-4-1422B, UNIT 4 SPENT FUEL PIT SOUTH WALL																		

THIS PAGE INTENTIONALLY LEFT BLANK

RECOGNITION CATEGORY F FISSION PRODUCT BARRIER DEGRADATION

**FISSION PRODUCT BARRIER TABLE WORKSHEET
(APPLICABILITY: Modes 1, 2, 3, & 4 ONLY)**

FUEL CLAD BARRIER		REACTOR COOLANT SYSTEM BARRIER		PRIMARY CONTAINMENT BARRIER	
1. Critical Safety Function Status		1. Critical Safety Function Status		1. Critical Safety Function Status	
1. CSF Status Tree for Core Cooling Red Conditions Met. (3/4 FR-C.1 Required)	1. CSF Status Tree for Core Cooling Orange Conditions Met. (3/4 FR-C.2 Required) OR 2. CSF Status Tree for Heat Sink Red Conditions Met. (3/4 FR-H.1 Required)	GUIDANCE BOX FOR SAFETY FUNCTION STATUS IN ALL THREE BARRIERS If directed to perform any mitigating step in applicable Function Restoration Procedures, THEN conditions have been met.	1. CSF Status Tree for Integrity Red Conditions Met. (3/4 FR-P.1 Required) OR 2. CSF Status Tree for Heat Sink Red Conditions Met. (3/4 FR-H.1 Required)	Not Applicable	1. CSF Status Tree for Containment Red Conditions Met. (3/4 FR-Z.1 Required)
OR		OR		OR	
2. Primary Coolant Activity Level		2. RCS Leak Rate		2. Containment Pressure	
1. Coolant activity greater than 300 uCi/gm Dose Equivalent I-131. GUIDANCE BOX See also SU4, Fuel Clad Degradation.	Not Applicable	1. RCS leak rate greater than available makeup capacity as indicated by a loss of RCS subcooling based on core exit TCs - LESS THAN 30°F [210°F]. GUIDANCE BOX See also SU5, RCS Leakage.	1. RCS leak rate indicated by greater than maximum charging with Leltdown isolated. GUIDANCE BOX Isolation of Leltdown is to distinguish between RCS leakage and CVCS leakage and is performed when procedurally required.	1. A containment pressure rise followed by a rapid unexplained drop in containment pressure. OR 2. Containment pressure or sump level response not consistent with LOCA conditions.	1. Containment pressure greater than 55 psig and rising. OR 2. 4% H ₂ in Containment OR 3.a. Containment Pressure greater than 20 psig. AND b. Less than one full train of depressurization equipment operating.
OR		OR		OR	
3. Core Exit Thermocouple Readings		3. Not Applicable		3. Core Exit Thermocouple Reading	
1. Core exit thermocouples reading greater than 1200 °F. GUIDANCE BOX At least five (5) Core Exit Thermocouples must exceed the threshold per F-0.	1. Core exit thermocouples reading greater than 700 °F. GUIDANCE BOX At least five (5) Core Exit Thermocouples must exceed the threshold per F-0.	Not Applicable		GUIDANCE BOX At least five (5) Core Exit Thermocouples must exceed the threshold per F-0. RVLMS Plenum indicating 0% indicates potential core uncover.	1.a. Core exit thermocouples in excess of 1200 °F. AND b. FR-C.1 NOT effective within 15 minutes. OR 2.a. Core exit thermocouples in excess of 700 °F. AND b. RVLMS indicates head voids. AND c. FR-C.2 NOT effective within 15 minutes.
OR		OR		OR	
4. Reactor Vessel Water Level		4. SG Tube Rupture		4. SG Secondary Side Release with P-to-S Leakage	
Not Applicable	1. RVLMS (OSPDS) 0% Plenum Indicated. GUIDANCE BOX RVLMS Plenum indicating 0% indicates potential core uncover.	1. RUPTURED SG results in a SI Actuation	Not Applicable	1. RUPTURED SG is also FAULTED outside of Containment. OR 2.a. Primary-to-Secondary leak rate greater than 10 gpm. AND b. UNISOLABLE steam release from affected SG to the environment.	Not Applicable
OR		OR		OR	
5. Not Applicable		5. Not Applicable		5. CNTMT Isolation Failure or Bypass	
Not Applicable	Not Applicable	Not Applicable	Not Applicable	1.a. Failure of all valves in any one line to close. AND b. Direct downstream pathway to the environment exists after containment isolation signal.	Not Applicable
OR		OR		OR	
6. Containment Radiation Monitoring		6. Containment Radiation Monitoring		6. Containment Radiation Monitoring	
1. CHRRM reading greater than 3.1 E+3 R/hr	Not Applicable	1. Containment Operating Floor radiation monitor RI-3-1402B [RI-4-1405B] reading greater than 110 mR/hr	Not Applicable	Not Applicable	1. CHRRM reading greater than 1.2 E+4 R/hr.
OR		OR		OR	
7. Emergency Coordinator Judgment		7. Emergency Coordinator Judgment		7. Emergency Coordinator Judgment	
1. Any condition in the opinion of the Emergency Coordinator that indicates Loss OR Potential Loss of the Fuel Clad Barrier.		1. Any condition in the opinion of the Emergency Coordinator that indicates Loss OR Potential Loss of the RCS Barrier.		1. Any condition in the opinion of the Emergency Coordinator that indicates Loss OR Potential Loss of the Containment Barrier.	
OR		OR		OR	
<input type="checkbox"/> FUEL CLAD BARRIER <input type="checkbox"/> LOSS <input type="checkbox"/> POTENTIAL LOSS		<input type="checkbox"/> REACTOR COOLANT SYSTEM BARRIER <input type="checkbox"/> LOSS <input type="checkbox"/> POTENTIAL LOSS		<input type="checkbox"/> PRIMARY CONTAINMENT BARRIER <input type="checkbox"/> LOSS <input type="checkbox"/> POTENTIAL LOSS	
ALERT <input type="checkbox"/> FA1 ANY Loss or ANY Potential Loss of EITHER Fuel Clad OR RCS				UNUSUAL EVENT <input type="checkbox"/> FU1 ANY Loss or ANY Potential Loss of Containment.	
SITE AREA EMERGENCY <input type="checkbox"/> FS1 Loss or Potential Loss of ANY two Barriers					
GENERAL EMERGENCY <input type="checkbox"/> FS2 Loss of ANY two Barriers AND Loss or Potential Loss of the Third Barrier					

**FISSION PRODUCT BARRIER TABLE BASIS
(APPLICABILITY: Modes 1, 2, 3, & 4 ONLY)**

FUEL CLAD BARRIER THRESHOLDS - BASIS	RCS BARRIER THRESHOLDS - BASIS	PRIMARY CONTAINMENT BARRIER THRESHOLDS - BASIS
<p>1. Critical Safety Function Status</p> <p>Loss Threshold #1 Core Cooling - RED indicates significant superheating and core uncover and is considered to indicate loss of the Fuel Clad Barrier. Potential Loss Threshold #1 Core Cooling - ORANGE indicates subcooling has been lost and that some clad damage may occur. Potential Loss Threshold #2 Heat Sink - RED when heat sink is required indicates the ultimate heat sink function is under extreme challenge.</p>	<p>1. Critical Safety Function Status</p> <p>Potential Loss Threshold #1 RCS integrity - RED indicates an extreme challenge to the safety function derived from appropriate instrument readings. Potential Loss Threshold #2 Heat Sink - RED when heat sink is required indicates the ultimate heat sink function is under extreme challenge. There is no Loss threshold associated with this item.</p>	<p>1. Critical Safety Function Status</p> <p>RED path indicates an extreme challenge to the safety function derived from appropriate instrument readings and/or sampling results, and thus represents a potential loss of containment. Conditions leading to a containment RED path result from RCS barrier and/or Fuel Clad Barrier Loss. Thus, this threshold is primarily a discriminator between Site Area Emergency and General Emergency representing a potential loss of the third barrier. There is no Loss threshold associated with this item.</p>
<p>2. Primary Coolant Activity Level</p> <p>The 300 µCi/gm I-131 equivalent indicates that this amount of coolant activity is well above that expected for iodine spikes and corresponds to less than 5% fuel clad damage. This amount of radioactivity indicates significant clad damage and thus the Fuel Clad Barrier is considered lost. There is no Potential Loss threshold associated with this item.</p>	<p>2. RCS Leak Rate</p> <p>Loss Threshold #1 This threshold addresses conditions where leakage from the RCS is greater than available inventory control capacity such that a loss of subcooling has occurred. The loss of subcooling is the fundamental indication that the Inventory Control Systems are inadequate in maintaining RCS pressure and inventory against the mass loss through the leak. Potential Loss Threshold #1 This threshold is based on the apparent inability to maintain normal liquid inventory within the Reactor Coolant System (RCS) by normal operation of the Chemical and Volume Control System. Isolating shutdown is a standard abnormal operating procedure action and may prevent unnecessary classifications when a non-RCS leakage path such as a CVCS leak exists. The intent of this condition is met if attempts to isolate shutdown are NOT successful.</p> <div style="border: 1px solid black; padding: 5px; text-align: center;"> <p>GUIDANCE BOX</p> <p>Minimum containment depressurization equipment requires 1 CSP and 1 ECC in the first 24 hours of the event, then 1 CSP and 2 ECCs after 24 hours. (Ref. FSAR 6.4., Containment Heat Removal Systems, Rev. 17.)</p> </div>	<p>2. Containment Pressure</p> <p>Loss Thresholds #1 or #2 Rapid unexplained loss of pressure (i.e., not attributable to containment spray or condensation effects) following an initial pressure increase from a primary or secondary high energy line break indicates a loss of containment integrity. Containment pressure and sump levels should increase as a result of mass and energy release into containment from a LOCA. Thus, sump level or pressure not increasing indicates containment bypass and a loss of containment integrity. This indicator relies on operator recognition of an unexpected response for the condition and therefore does not have a specific value associated with it. The unexpected response is important because it is the indicator for a containment bypass condition. Potential Loss Threshold #1 The Threshold Value is the containment design pressure. Potential Loss Threshold #2 Existence of an explosive mixture means a hydrogen and oxygen concentration of at least the lower deflagration limit curve exists. The indications of potential loss under this EAL corresponds to some of those leading to the RED path in potential loss threshold #1 above and may be declared by those sites using CSFSTs. Potential Loss Threshold #3 This threshold represents a potential loss of containment in that the Containment Heat Removal/Depressurization System are either lost or performing in a degraded manner, as indicated by containment pressure greater than the setpoint at which the equipment was supposed to have actuated.</p>
<p>3. Core Exit Thermocouple Readings</p> <p>Loss Threshold #1 The Threshold Value corresponds to significant superheating of the coolant. Potential Loss Threshold #1 The Threshold Value corresponds to loss of subcooling.</p>	<p>3. Not Applicable Not Applicable (included for numbering consistency between barrier tables).</p>	<p>3. Core Exit Thermocouple Reading</p> <p>There is no Loss threshold associated with this item. Potential Loss Threshold #1 The conditions in these thresholds represent an IMMINENT core melt sequence which, if not corrected, could lead to vessel failure and an increased potential for containment failure. In conjunction with the Core Cooling and RCS Leakage criteria in the Fuel and RCS barrier columns, this threshold would result in the declaration of a General Emergency - loss of two barriers and the potential loss of a third. If the function restoration procedures are ineffective, there is no "success" path. The function restoration procedures are those emergency operating procedures that address the recovery of the core cooling critical safety functions. The procedure is considered effective if the temperature is decreasing or if the vessel water level is increasing. Severe accident analyses (e.g., NUREG-1150) have concluded that function restoration procedures can arrest core degradation within the reactor vessel in a significant fraction of the core damage scenarios, and that the likelihood of containment failure is very small in these events. Filtered mixture provides a reasonable period to allow function restoration procedures to arrest the core melt sequence. Whether or not the procedures will be effective should be apparent within 15 minutes. The Emergency Coordinator should make the declaration as soon as it is determined that the procedures have been, or will be, ineffective. Potential Loss Threshold #2 The Threshold Value is consistent with the Emergency Operating Procedures.</p>
<p>4. Reactor Vessel Water Level</p> <p>There is no Loss threshold associated with this item. The Threshold Value for the Potential Loss threshold corresponds to the top of the active fuel.</p>	<p>4. SG Tube Rupture</p> <p>This threshold addresses the full spectrum of Steam Generator (SG) tube rupture events in conjunction with Containment Barrier Loss thresholds. It addresses RUPTURED SG(s) for which the leakage is large enough to cause escalation of ECCS (S1). This is consistent to the RCS leak rate barrier Potential Loss threshold. By itself, this threshold will result in the declaration of an Alert. However, if the SG is also FAULTED (i.e., two barriers failed), the declaration escalates to a Site Area Emergency per Containment Barrier Loss thresholds. There is no Potential Loss threshold associated with this item.</p> <div style="border: 1px solid black; padding: 5px;"> <p>DEFINITION BOX</p> <p>FAULTED - In a steam generator, the existence of secondary side leakage that results in an uncontrolled drop in steam generator pressure or the steam generator being completely depressurized.</p> <p>RUPTURED - In a steam generator, existence of primary-to-secondary leakage of a magnitude sufficient to require or cause a reactor trip and safety injection.</p> <p>UNISOLABLE - A breach or leak that cannot be promptly isolated.</p> </div>	<p>4. SG Secondary Side Release with P-to-S Leakage</p> <p>The loss threshold recognizes that SG tube leakage can represent a bypass of the Containment barrier as well as a loss of the RCS barrier. Users should realize that the two loss thresholds could be considered redundant. This was recognized during the development process. The inclusion of an threshold that uses Emergency Procedure commonly used terms like "RUPTURED and FAULTED" adds to the ease of the classification process and has been included based on this human factor concern. This threshold results in a NOUE for smaller breaks that: (1) do not exceed the normal charging capacity threshold in RCS leak rate barrier Potential Loss threshold, or (2) do not result in ECCS actuation in RCS SG tube rupture barrier Loss threshold. For larger breaks, RCS barrier threshold criteria would result in an Alert. For SG tube ruptures which may involve multiple steam generators or unisolable secondary line breaks, this threshold would exist in conjunction with RCS barrier thresholds and would result in a Site Area Emergency. Escalation to General Emergency would be based on "Potential Loss" of the Fuel Clad Barrier. Loss Threshold #1 This threshold addresses the condition in which a RUPTURED steam generator is also FAULTED. The condition represents a bypass of the RCS and containment barriers and is a subset of the second threshold. In conjunction with RCS leak rate barrier loss threshold, this would always result in the declaration of a Site Area Emergency. Loss Threshold #2 This threshold addresses SG tube leaks that exceed 10 gpm in conjunction with an UNISOLABLE release path to the environment from the affected steam generator. The threshold for establishing the UNISOLABLE secondary side release is intended to be a prolonged release of radioactivity from the RUPTURED steam generator directly to the environment. This could be expected to occur when the main condenser is unavailable to accept the contained steam (i.e., SG tube rupture with concurrent loss of off-site power and the RUPTURED steam generator is required for plant cooldown or a stuck open relief valve). If the main condenser is available, there may be releases via air ejectors, gland seal exhausters, and other similar controlled, and often monitored, pathways. These pathways do not meet the intent of an UNISOLABLE release path to the environment. These minor releases are assessed using Abnormal Rad Levels / Radiological Effluent ICS.</p>
<p>5. Not Applicable Not Applicable (included for numbering consistency between barrier tables).</p>	<p>5. Not Applicable Not Applicable (included for numbering consistency between barrier tables).</p>	<p>5. CNTMT Isolation Failure or Bypass</p> <p>This threshold addresses incomplete containment isolation that allows direct release to the environment. The use of the modifier "direct" in defining the release path discriminates against release paths through interfacing liquid systems. The existence of an in-line charcoal filter does not make a release path indirect since the filter is not effective at removing fission product noble gases. Typical filters have an efficiency of 95-99% removal of iodine. Given the magnitude of the core inventory of iodine, significant releases could still occur. In addition, since the fission product release would be driven by boiling in the reactor vessel, the high humidity in the release stream can be expected to render the filters ineffective in a short period. There is no Potential Loss threshold associated with this item.</p>
<p>6. Containment Radiation Monitoring</p> <p>The Threshold Value indicates the release of reactor coolant, with elevated activity indicative of fuel damage, into the containment assuming the instantaneous release and dispersal of the reactor coolant noble gas and iodine inventory associated with a concentration of 300 µCi/gm dose equivalent I-131 into the containment atmosphere. Reactor coolant concentrations of this magnitude are several times larger than the maximum concentrations (including iodine spiking) allowed within technical specifications and are therefore indicative of fuel damage. This value is higher than that specified for RCS barrier Loss threshold #1. Thus, this threshold indicates a loss of both the Fuel Clad barrier and RCS barrier that appropriately escalates the emergency classification level to a Site Area Emergency. There is no Potential Loss threshold associated with this item.</p>	<p>6. Containment Radiation Monitoring</p> <p>The Threshold Value indicates the release of reactor coolant to the containment assuming the instantaneous release and dispersal of the reactor coolant noble gas and iodine inventory associated with normal operating concentrations (i.e., within T/S) into the containment atmosphere. This value is less than that specified for Fuel Clad barrier Threshold 6.1. Thus, this threshold would be indicative of a RCS leak only. If the radiation monitor reading increased to that specified by Fuel Clad barrier threshold, fuel damage would also be indicated. There is no Potential Loss threshold associated with this item.</p>	<p>6. Containment Radiation Monitoring</p> <p>There is no Loss threshold associated with this item. The Threshold Value indicates significant fuel damage well in excess of the thresholds associated with both loss of Fuel Clad and loss of RCS barriers. A major release of radioactivity requiring off-site protective actions from core damage is not possible unless a major failure of fuel cladding allows radioactive material to be released from the core into the reactor coolant. The Threshold Value indicates the release of reactor coolant to the containment assuming the instantaneous release and dispersal of the reactor coolant noble gas and iodine inventory associated with 20% fuel clad damage into the containment atmosphere. Regardless of whether containment is challenged, this amount of activity in containment, if released, could have such severe consequences that it is prudent to treat this as a potential loss of containment, such that a General Emergency declaration is warranted.</p>
<p>7. Emergency Coordinator Judgment</p> <p>These thresholds address any other factors that are to be used by the Emergency Coordinator in determining whether the Fuel Clad barrier is lost or potentially lost. In addition, the inability to monitor the barrier should also be incorporated in this threshold as a factor in Emergency Coordinator judgment that the barrier may be considered lost or potentially lost.</p>	<p>7. Emergency Coordinator Judgment</p> <p>These thresholds address any other factors that are to be used by the Emergency Coordinator in determining whether the RCS barrier is lost or potentially lost. In addition, the inability to monitor the barrier should also be incorporated in this threshold as a factor in Emergency Coordinator judgment that the barrier may be considered lost or potentially lost.</p>	<p>7. Emergency Coordinator Judgment</p> <p>These thresholds address any other factors that are to be used by the Emergency Coordinator in determining whether the Containment barrier is lost or potentially lost. In addition, the inability to monitor the barrier should also be incorporated in this threshold as a factor in Emergency Coordinator judgment that the barrier may be considered lost or potentially lost. The Containment barrier should not be declared lost or potentially lost based on exceeding Technical Specification action statement criteria, unless there is an event in progress requiring mitigation by the Containment barrier. When no event is in progress (Loss or Potential Loss of either Fuel Clad and/or RCS) the Containment barrier status is addressed by Technical Specifications.</p>



This Page Intentionally Left Blank



RECOGNITION CATEGORY S SYSTEM MALFUNCTIONS

Rec. Cat.	Site Area Emergency	Alert	Unusual Event
<p>SG1 – Basis:</p> <p>Loss of all AC power to emergency busses compromises all plant safety systems requiring electric power including RHR, ECCS, Containment Heat Removal, and the Ultimate Heat Sink. Prolonged loss of all AC power to emergency busses will lead to loss of Fuel Clad, RCS, and containment, thus warranting declaration of a General Emergency.</p> <p>The 4 hours to restore AC power is based on a site blackout coping analysis performed in accordance with 10 CFR 50.63 and Regulatory Guide 1.155, "Station Blackout". Although this IC may be viewed as redundant to the Fission Product Barrier IC, its inclusion is necessary to better assure timely recognition and emergency response.</p> <p>This IC is specified to assure that in the unlikely event of a prolonged station blackout, timely recognition of the seriousness of the event occurs and that declaration of a General Emergency occurs as early as is appropriate, based on a reasonable assessment of the event trajectory.</p> <p>The likelihood of restoring at least one emergency bus should be based on a realistic appraisal of the situation since a delay in an upgrade decision based on only a chance of mitigating the event could result in a loss of valuable time in preparing and implementing public protective actions.</p> <p>In addition, under these conditions, fission product barrier monitoring capability may be degraded.</p> <p>Although it may be difficult to predict when power can be restored, a reasonable indication of how quickly the need to declare a General Emergency based on two major considerations:</p> <ol style="list-style-type: none"> 1. Are there any present indications that core cooling is already degraded to the point that loss or potential loss of Fission Product Barriers is IMMINENT? 2. If there are no present indications of such core cooling degradation, how likely is it that power can be restored in time to assure that loss of two barriers with a potential loss of the third barrier can be prevented? <p>Thus, indication of continuing core cooling degradation must be based on Fission Product Barrier monitoring with particular emphasis on Emergency Coordinator judgment as it relates to IMMINENT loss or potential loss of fission product barriers and degraded ability to monitor fission product barriers.</p>	<p>SS1 – Basis:</p> <p>Loss of all AC power to emergency busses compromises all plant safety systems requiring electric power including RHR, ECCS, Containment Heat Removal, and the Ultimate Heat Sink. Prolonged loss of all AC power to emergency busses will lead to loss of Fuel Clad, RCS, and Containment, thus this event can escalate to a General Emergency.</p> <p>Fifteen minutes was selected as a threshold to exclude transient or momentary losses of off-site power.</p> <p>An SBO crossite, from the unaffected unit through each unit's D 4KV buses, that can be accomplished using 3/4EOP-ECA-0.0 within the 15 minutes will provide an alternate power source.</p> <p>Escalation to General Emergency is via Fission Product Barrier Degradation or IC SG1. Prolonged Loss of All Off-site Power, and Prolonged Loss of All On-site AC Power.</p>	<p>SA5 – Basis:</p> <p>The condition indicated by this IC is the degradation of the off-site and on-site AC power systems such that any additional single failure would result in a unit blackout. This condition could occur due to a loss of off-site power with a concurrent failure of all but one emergency generator to supply power to its emergency busses. Another related condition could be the loss of all off-site power and loss of on-site emergency generators with only one train of emergency busses being backed from the unit main generator, or the loss of on-site emergency generators with only one train of emergency busses being backed from off-site power.</p> <p>The subsequent loss of this single power source would escalate the event to a Site Area Emergency in accordance with SS1.</p> <p>Fifteen minutes was selected as a threshold to exclude transient or momentary losses of power.</p> <p>An SBO crossite from the unaffected unit through each unit's D 4KV buses, that can be accomplished using 3/4EOP-ECA-0.0 within the 15 minutes, will provide an alternate power source.</p>	<p>SU1 – Basis:</p> <p>Prolonged loss of off-site AC power reduces required redundancy and potentially degrades the level of safety of the plant by rendering the plant more vulnerable to a complete loss of AC power to emergency busses. Fifteen minutes was selected as a threshold to exclude transient or momentary losses of off-site power.</p> <p>An SBO crossite, from the unaffected unit through each unit's D 4KV buses, that can be accomplished using 3/4EOP-ECA-0.0 within the 15 minutes will provide an alternate power source.</p>
<p>SS2 – Basis:</p> <p>Under these conditions, the reactor is producing more heat than the maximum decay heat load for which the safety systems are designed and efforts to bring the reactor subcritical are unsuccessful. A Site Area Emergency is warranted because conditions exist that lead to IMMINENT loss or potential loss of both fuel clad and RCS.</p> <p>Manual trip actions taken in the Control Room are any set of actions by the reactor operator(s) at which causes or should cause control rods to be rapidly inserted into the core and shuts down the reactor.</p> <p>Manual trip actions are not considered successful if action away from the reactor control console is required to trip the reactor. This threshold is still applicable even if actions taken away from Control Room are successful in shutting the reactor down because the design limits of the fuel may have been exceeded or because of the gross failure of the Reactor Protection System to shutdown the plant.</p> <p>The Subcriticality Red Path is met when power is not reduced below 5% after a trip.</p> <p>Escalation of this event to a General Emergency would be due to a prolonged condition leading to an extreme challenge to either core-cooling or heat removal.</p>	<p>SA2 – Basis:</p> <p>Manual trip actions taken in the Control Room are any set of actions by the reactor operator(s) which causes or should cause control rods to be rapidly inserted into the core and shuts down the reactor.</p> <p>This condition indicates failure of the automatic protection system to trip the reactor. This condition is more than a potential degradation of a safety system in that a front line automatic protection system did not function in response to a plant transient. Thus the plant safety has been compromised because design limits of the fuel may have been exceeded. An Alert is indicated because conditions may exist that lead to potential loss of fuel clad or RCS and because of the failure of the Reactor Protection System to automatically shutdown the plant.</p> <p>The Subcriticality Red Path is met when power is not reduced below 5% after a trip.</p> <p>If manual actions taken in the Control Room fail to shutdown the reactor, the event would escalate to a Site Area Emergency.</p>	<p>SU8 – Basis:</p> <p>This IC addresses inadvertent critically events. This IC indicates a potential degradation of the level of safety of the plant, warranting a NOUE classification. This IC excludes inadvertent criticalities that occur during planned reactivity changes associated with reactor startups (e.g., critically earlier than estimated).</p> <p>Escalation would be by the Fission Product Barrier Table, as appropriate to the operating mode at the time of the event.</p>	<p>SS3 – Basis:</p> <p>Loss of all DC power compromises ability to monitor and control plant safety functions. Prolonged loss of all DC power will cause core uncovering and loss of containment integrity when there is significant decay heat and sensible heat in the reactor system.</p> <p>105 VDC is the voltage at which continued functions of control systems is no longer guaranteed. Fifteen minutes was selected as a threshold to exclude transient or momentary power losses.</p> <p>Escalation to a General Emergency would occur by Abnormal Rad Levels/Radiological Effluent, Fission Product Barrier Degradation.</p>
<p>SG2 – Basis:</p> <p>Under these conditions, the reactor is producing more heat than the maximum decay heat load for which the safety systems are designed and efforts to bring the reactor subcritical are unsuccessful.</p> <p>CSF Subcriticality – Red is met when power is greater than 5% after a trip.</p> <p>In the event either of these challenges exists at a time that the reactor has not been brought below 5% power a core melt sequence exists. In this situation, core degradation can occur rapidly. For this reason, the General Emergency declaration is intended to be anticipatory of the fission product barrier table declaration to permit maximum off-site intervention time.</p>	<p>SA2 – Basis:</p> <p>Manual scram (trip) actions taken at the reactor control console are any set of actions by the reactor operator(s) which causes or should cause control rods to be rapidly inserted into the core and shuts down the reactor. (NEI 99-01, Rev. 5, SA2 Basis, Page 138, SS2 Basis, Page 143)</p>	<p>DEFINITION BOX</p> <p>IMMINENT – Mitigation actions have been ineffective, additional actions are not expected to be successful, and trended information indicates that the event or condition will occur. Where IMMINENT timeframes are specified, they shall apply.</p> <p>UNPLANNED – A parameter change or an event that is not the result of an intended evolution and requires corrective or mitigative actions.</p>	<p>DEFINITION BOX</p> <p>IMMINENT – Mitigation actions have been ineffective, additional actions are not expected to be successful, and trended information indicates that the event or condition will occur. Where IMMINENT timeframes are specified, they shall apply.</p> <p>UNPLANNED – A parameter change or an event that is not the result of an intended evolution and requires corrective or mitigative actions.</p>

5 – SYSTEM MALFUNCTIONS

Reception Category		S – SYSTEM MALFUNCTIONS	
SG1 Prolonged Loss of All Off-site and All On-Site AC Power to Emergency Buses. Operating Mode Applicability: 1, 2, 3, 4 Threshold Value: 1. a. Loss of all off-site and all on-site AC power to 3f4jA 4KV and 3f4jB 4KV Buses. AND b. EITHER of the following: • Restoration of at least one emergency bus in less than 4 hours is not likely. • CSF Status Tree for Core Cooling - Orange Conditions Met.	Alert SA5 AC Power Capability to Emergency Buses Reduced To A Single Power Source For 15 Minutes or Longer Such That Any Additional Single Failure Would Result In Unit Blackout Operating Mode Applicability: 1, 2, 3, 4 Threshold Value: Note: The Emergency Coordinator should not wait until the applicable time has elapsed, but should declare the event as soon as it is determined that the condition has exceeded, or will likely exceed, the applicable time. 1. Loss of all off-site AC power to 3f4jA 4KV and 3f4jB 4KV Buses for 15 minutes or longer. AND b. Any additional single power source failure will result in unit blackout.	Unusual Event SU1 Loss of All Off-site AC Power to Emergency Buses for 15 Minutes or Longer. Operating Mode Applicability: 1, 2, 3, 4 Threshold Value: Note: The Emergency Coordinator should not wait until the applicable time has elapsed, but should declare the event as soon as it is determined that the condition has exceeded, or will likely exceed, the applicable time. 1. Loss of all off-site AC power to 3f4jA 4KV and 3f4jB 4KV Buses for 15 minutes or longer.	AC POWER
SS1 Loss of All Off-site and All On-Site AC Power to Emergency Buses for 15 minutes or longer. Operating Mode Applicability: 1, 2, 3, 4 Threshold Value: Note: The Emergency Coordinator should not wait until the applicable time has elapsed, but should declare the event as soon as it is determined that the condition has exceeded, or will likely exceed, the applicable time. 1. Loss of all Off-Site and all On-Site AC power to 3f4jA 4KV and 3f4jB 4KV Buses for 15 minutes or longer.	SA2 Automatic Trip Fails to Shutdown the Reactor AND the Manual Actions Taken in the Control Room are NOT Successful in Shutting Down the Reactor. Operating Mode Applicability: 1, 2 Threshold Value: 1. a. An automatic trip failed to shutdown the reactor. AND b. Manual actions taken in the Control Room do not shutdown the reactor as indicated by CSF Status Tree Subcriticality - Red Path Conditions Met. GUIDANCE BOX FOR SS2 Manual scram (trip) actions taken at the reactor control console are any set of actions by the reactor operator(s) which causes or should cause control rods to be rapidly inserted into the core and shuts down the reactor. (NEI 99-01, Rev. 5, SS2 Basis, Page 145)	SU8 Inadvertent Criticality. Operating Mode Applicability: 3, 4 Threshold Value: 1. UNPLANNED sustained positive startup rate observed on nuclear instrumentation.	
SS2 Automatic Trip Fails to Shutdown the Reactor AND Manual Actions Taken in the Control Room are NOT Successful in Shutting Down the Reactor. Operating Mode Applicability: 1, 2 Threshold Value: 1. a. An automatic trip failed to shutdown the reactor. AND b. Manual actions taken in the Control Room do not shutdown the reactor as indicated by CSF Status Tree Subcriticality - Red Path Conditions Met. GUIDANCE BOX FOR SS2 Manual scram (trip) actions taken at the reactor control console are any set of actions by the reactor operator(s) which causes or should cause control rods to be rapidly inserted into the core and shuts down the reactor. (NEI 99-01, Rev. 5, SS2 Basis, Page 145)	SA2 Automatic Trip Fails to Shutdown the Reactor AND the Manual Actions Taken in the Control Room are NOT Successful in Shutting Down the Reactor. Operating Mode Applicability: 1, 2 Threshold Value: 1. a. An automatic trip failed to shutdown the reactor. AND b. Manual actions taken in the Control Room do not shutdown the reactor as indicated by CSF Status Tree for Subcriticality - Red Path Conditions NOT Met. GUIDANCE BOX FOR SA2 Manual scram (trip) actions taken at the reactor control console are any set of actions by the reactor operator(s) which causes or should cause control rods to be rapidly inserted into the core and shuts down the reactor. (NEI 99-01, Rev. 5, SA2 Basis, Page 138)	SU8 Inadvertent Criticality. Operating Mode Applicability: 3, 4 Threshold Value: 1. UNPLANNED sustained positive startup rate observed on nuclear instrumentation.	DC POWER
SS3 Loss of All Vital DC Power for 15 Minutes or Longer. Operating Mode Applicability: 1, 2, 3, 4 Threshold Value: Note: The Emergency Coordinator should not wait until the applicable time has elapsed, but should declare the event as soon as it is determined that the condition has exceeded, or will likely exceed, the applicable time. 1. Less than 105 VDC on all of the following Vital DC buses for 15 minutes or longer: • 3D01, 3D23 • 4D01, 4D23	DEFINITION BOX IMMINENT - Mitigation actions have been ineffective, additional actions are not expected to be successful, and trended information indicates that the event or condition will occur. Where IMMINENT timerframes are specified, they shall apply. UNPLANNED - A parameter change or an event that is not the result of an intended evolution and requires corrective or mitigative actions.		

Recognition Category		S - SYSTEM MALFUNCTIONS	
<p>Site Area Emergency</p> <p>SS6 Inability to Monitor a SIGNIFICANT TRANSIENT in Progress. Operating Mode Applicability: 1, 2, 3, 4</p> <p>Threshold Value:</p> <p>Note: The Emergency Coordinator should not wait until the applicable time has elapsed, but should declare the event as soon as it is determined that the condition has exceeded, or will likely exceed, the applicable time.</p> <p>1. a. Loss of ANY 3 of the following Annunciator panels for 15 minutes or longer: Panel A Panel B Panel C Panel H <u>OR</u> Loss of ANY 2 of the following instrument buses: 3(4)P06 3(4)P07 3(4)P08 3(4)P09 <u>AND</u> Any of the following: • Automatic turbine rumback greater than 25% thermal reactor power • Electrical load rejection greater than 25% full electrical load, • Reactor Trip • Safety Injection Activation <u>AND</u> 3. Inability to Monitor Critical Safety Functions</p>	<p>Alert</p> <p>SA4 UNPLANNED Loss of Safety System Annunciator or Indication in the Control Room With Either (1) a SIGNIFICANT TRANSIENT in Progress, or (2) Compensatory Indicators Unavailable. Operating Mode Applicability: 1, 2, 3, 4</p> <p>Threshold Value:</p> <p>Note: The Emergency Coordinator should not wait until the applicable time has elapsed, but should declare the event as soon as it is determined that the condition has exceeded, or will likely exceed, the applicable time.</p> <p>1. a. UNPLANNED Loss for 15 minutes or longer of: Panel A Panel B Panel C Panel H <u>OR</u> ANY 2 of the following instrument buses: 3(4)P06 3(4)P07 3(4)P08 3(4)P09 <u>AND</u> Any of the following: • Automatic turbine rumback greater than 25% thermal reactor power • Electrical load rejection greater than 25% full electrical load, • Reactor Trip • Safety Injection Activation <u>OR</u> b. Inability to monitor Critical Safety Functions</p>	<p>Unusual Event</p> <p>SU3 UNPLANNED Loss of Safety System Annunciator or Indication in the Control Room for 15 Minutes or Longer Operating Mode Applicability: 1, 2, 3, 4</p> <p>Threshold Value:</p> <p>Note: The Emergency Coordinator should not wait until the applicable time has elapsed, but should declare the event as soon as it is determined that the condition has exceeded, or will likely exceed, the applicable time.</p> <p>1. a. UNPLANNED Loss for 15 minutes or longer of: Panel A Panel B Panel C Panel H <u>OR</u> ANY 3 of the following Annunciator panels: 3(4)P06 3(4)P07 3(4)P08 3(4)P09 b. ANY 2 of the following instrument buses: 3(4)P06 3(4)P07 3(4)P08 3(4)P09</p>	<p>ANNUNCIATORS</p>
<p>RCS LEAKAGE</p> <p>SU5 RCS Leakage. Operating Mode Applicability: 1, 2, 3, 4</p> <p>Threshold Value:</p> <p>1. Unidentified OR pressure boundary leakage greater than 10 gpm. <u>OR</u> 2. Identified leakage greater than 25 gpm.</p>	<p>RCS LEAKAGE</p> <p>SU5 RCS Leakage. Operating Mode Applicability: 1, 2, 3, 4</p> <p>Threshold Value:</p> <p>1. Unidentified OR pressure boundary leakage greater than 10 gpm. <u>OR</u> 2. Identified leakage greater than 25 gpm.</p>	<p>FUEL CLAD</p> <p>SU4 Fuel Clad Degradation. Operating Mode Applicability: 1, 2, 3, 4</p> <p>Threshold Values:</p> <p>1. VALID High alarm on R-3(4)20, Reactor Coolant Lealdown Monitor. <u>OR</u> 2. Coolant sample activity value indicating fuel clad degradation greater than EITHER: • 1 uCi/gm Dose Equivalent I-131 • 100E uCi/gm gross radioactivity.</p>	<p>RCS LEAKAGE - According to Technical Specifications, leakage through a steam generator to any system (primary or secondary leakage) is IDENTIFIED Reactor Coolant System (RCS) leakage. (Ref: TS 1.16)</p> <p>GUIDANCE BOX FOR SU5</p> <p>GUIDANCE BOX FOR SU4</p> <p>Planned evolutions to test, manipulate, repair, perform maintenance or modifications to systems and equipment that result in an EAL value being met or exceeded are not subject to classification and activation requirements as long as the evolution proceeds as planned and is within the operational limitations imposed by the specific operating license. [Turkey Point Technical Basis, 3.9]</p>
<p>TECH SPECS</p> <p>SU2 Inability to Reach Required Shutdown Within Technical Specification Limits. Operating Mode Applicability: 1, 2, 3, 4</p> <p>Threshold Value:</p> <p>1. Plant is NOT brought to required operating mode within Technical Specifications LCO Action Statement Time.</p>	<p>TECH SPECS</p> <p>SU2 Inability to Reach Required Shutdown Within Technical Specification Limits. Operating Mode Applicability: 1, 2, 3, 4</p> <p>Threshold Value:</p> <p>1. Plant is NOT brought to required operating mode within Technical Specifications LCO Action Statement Time.</p>	<p>TECH SPECS</p> <p>SU2 Inability to Reach Required Shutdown Within Technical Specification Limits. Operating Mode Applicability: 1, 2, 3, 4</p> <p>Threshold Value:</p> <p>1. Plant is NOT brought to required operating mode within Technical Specifications LCO Action Statement Time.</p>	<p>DEFINITION BOX</p> <p>SIGNIFICANT TRANSIENT - An UNPLANNED event involving one or more of the following: (1) automatic turbine rumback greater than 25% thermal reactor power, (2) electrical load rejection greater than 25% full electrical load, (3) Reactor Trip, or (4) Safety Injection Activation.</p> <p>UNPLANNED - A parameter change or an event that is not the result of an intended evolution and requires corrective or mitigative actions.</p> <p>VALID - An indication, report, or condition, is considered to be VALID when it is verified by (1) an instrument channel check, (2) indications on related or redundant indicators, or (3) by direct observation by plant personnel, such that doubt related to the indicator's operability, the condition's existence, or the report's accuracy is removed. Implicit in this definition is the need for timely assessment.</p>

Rec. Cat.	Site Area Emergency	Alert	Unusual Event
S - SYSTEM MALFUNCTIONS			<p>SU6 - Basis:</p> <p>The purpose of this IC and its associated Thresholds is to recognize a loss of communications capability that either defeats the plant operations staff ability to perform routine tasks necessary for plant operations or the ability to communicate issues with off-site authorities.</p> <p>The availability of one method of ordinary off-site communications is sufficient to inform federal, state, and local authorities of plant problems. This Threshold is to be used only when extraordinary means (e.g., relaying of information from non-routine radio transmissions, individuals being sent to off-site locations, etc.) are being used to make communications possible.</p> <p>The lists for on-site communications and off-site communications loss encompasses the loss of all means of communications routinely used for operations and for offsite emergency notifications respectively.</p>

Emergency	Site Area Emergency	Alert	Unusual Event	Recognition Category	
			<p>SU6 Loss of All On-site or Off-site Communications Capabilities.</p> <p>Operating Mode Applicability: 1, 2, 3, 4</p> <p>Threshold Values:</p> <ol style="list-style-type: none"> Loss of all of the following on-site communication methods affecting the ability to perform routine operations. <ul style="list-style-type: none"> Plant Page Plant Radios Plant Phones <p>OR</p> <ol style="list-style-type: none"> Loss of all of the following off-site communication methods affecting the ability to perform either of the following offsite notifications. <ul style="list-style-type: none"> Commercial Telephones * Federal Telecommunications System (FTS) 	<p>S - SYSTEM MALFUNCTIONS</p> <p>COMMUNICATIONS</p>	
<p>GUIDANCE BOX FOR SU6</p> <p>The following communications systems are available for off-site notifications from the Control Room:</p> <ol style="list-style-type: none"> State and County Notifications: <ul style="list-style-type: none"> Commercial Telephones * Hot Ring Down (HRD) NRC Notification <ul style="list-style-type: none"> Emergency Notification System (ENS) Commercial Telephones <p>* Commercial phones include plant phones, direct outside lines and installed cell phones in the Control Room, but not personal cell phones</p>					

This Page Intentionally Left Blank

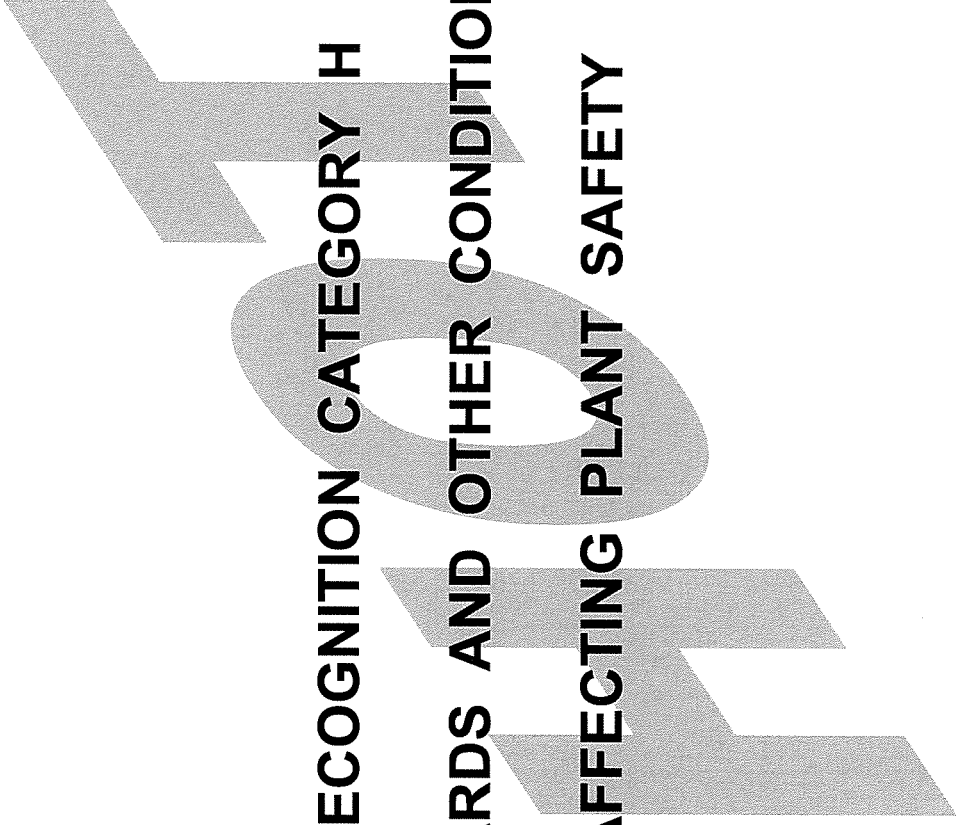

**RECOGNITION CATEGORY H
HAZARDS AND OTHER CONDITIONS
AFFECTING PLANT SAFETY**

Rec. Cat.	Site Area Emergency	Alert	Unusual Event
<p align="center">H - HAZARDS AND OTHER CONDITIONS AFFECTING PLANT SAFETY</p>	<p align="center">DEFINITION BOX</p> <p>EXPLOSION – A rapid, violent, unconfined combustion, or catastrophic failure of pressurized/energized equipment that imparts energy of sufficient force to potentially damage permanent structures, systems, or components.</p> <p>FIRE – Combustion characterized by heat and light. Sources of smoke such as slipping drive belts or overheated electrical equipment do not constitute FIRES. Observation of flame is preferred but is NOT required if large quantities of smoke and heat are observed.</p> <p>NORMAL PLANT OPERATIONS – Activities at the plant site associated with routine testing, maintenance, or equipment operations, in accordance with normal operating or administrative procedures. Entry into abnormal conditions, or specifically, the decision to depart from normal security or radiological controls posture, is a departure from NORMAL PLANT OPERATIONS.</p> <p>PROJECTILE – An object directed toward a Nuclear Power Plant (NPP) that could cause concern for its continued operability, reliability, or personnel safety.</p> <p>PROTECTED AREA – The area (within the Owner Controlled Area) occupied by the nuclear units and associated equipment and facilities enclosed within the security perimeter fence. The area within which accountability of personnel is maintained in an emergency. This does not include the ISFSI Protected Area.</p> <p>VISIBLE DAMAGE – Damage to equipment or structure that is readily observable without measurements, testing, or analysis. Damage is sufficient to cause concern regarding the continued operability or reliability of the affected structure, system, or component. Example damage includes: deformation due to heat or impact, denting, penetration, rupture, cracking, and paint blistering. Surface blemishes (e.g., paint chipping, scratches) should not be included.</p> <p>VITAL AREAS – Areas within the PROTECTED AREA, that contains equipment, systems, components, or material, the failure, destruction, or release of which could directly or indirectly endanger the public health and safety by exposure to radiation.</p>	<p>HA1 – Basis:</p> <p>These Thresholds escalate from HU1 in that the occurrence of the event has resulted in VISIBLE DAMAGE to plant structures or areas containing equipment necessary for a safe shutdown, or has caused damage to the safety systems in those structures evidenced by Control Room indications of degraded system response or performance.</p> <p>The occurrence of VISIBLE DAMAGE and/or degraded system response is intended to discriminate against lesser events. The initial report should not be interpreted as mandating a lengthy damage assessment prior to classification. No attempt is made in this Threshold to assess the actual magnitude of the damage. The significance here is not that a particular system or structure was damaged, but rather, that the event was of sufficient magnitude to cause this degradation.</p> <p>Escalation of this emergency classification level, if appropriate, would be based on System Malfunction (S).</p> <p>Threshold #1</p> <p>Seismic events of this magnitude can result in a VITAL AREA being subjected to forces beyond design basis. This includes, but is not limited to, the occurrence of a seismic event with Modified Mercalli Intensity V (0.04 – 0.09 g) is indicated by:</p> <ul style="list-style-type: none"> Felt by nearly everyone Light damage, some windows broken, or unstable objects overturned. <p>The ETNA Seismograph Event Recorder Red LED indicator ON indicates an event has been recorded. The red LED indicator flashing indicates an event is being recorded or the device is writing to memory; I&C should be contacted immediately.</p> <p>The USGS National Earthquake Information Center can confirm if an earthquake has occurred in the area of the plant.</p> <p>Threshold #2</p> <p>This Threshold is based on a tornado striking (touching down) or high winds that have caused VISIBLE DAMAGE to structures containing functions or systems required for safe shutdown of the plant.</p> <p>Threshold #3</p> <p>This Threshold addresses the effect of internal flooding caused by events such as component failures, equipment misalignment, or outage activity mishaps. It is based on the degraded performance of systems, or that has created industrial safety hazards (e.g., electrical shock) that preclude necessary access to operate or monitor safety equipment. The inability to access, operate, or monitor safety equipment represents an actual or substantial potential degradation of the level of safety of the plant.</p> <p>Flooding as used in this Threshold describes a condition where water is entering the room faster than installed equipment is capable of removal, resulting in a rise of water level within the room to isolate the water source.</p> <p>Threshold #5</p> <p>This Threshold addresses vehicle crashes within the PROTECTED AREA that results in VISIBLE DAMAGE to VITAL AREAS or indication of damage to safety structures, systems, or components containing functions and systems required for safe shutdown of the plant.</p> <p>Threshold #6</p> <p>This Threshold addresses other natural phenomena that result in VISIBLE DAMAGE to VITAL AREAS or results in indication of damage to safety structures, systems, or components containing functions and systems required for safe shutdown of the plant in the event of a hurricane and the associated storm surge that can also be precursors of more serious events.</p>	<p>HU1 – Basis:</p> <p>These Thresholds are categorized on the basis of the occurrence of an event of sufficient magnitude to be of concern to plant operators.</p> <p>Threshold #1</p> <p>Damage may be caused to some portions of the site, but should not affect ability of safety functions to operate. The Modified Mercalli Intensity IV (0.01 – 0.04 g) is indicated by:</p> <ul style="list-style-type: none"> Felt indoors by many, outdoors by few No damage <p>As defined in the EPRI-sponsored Guidelines for Nuclear Plant Response to an Earthquake, dated October 1989, a "felt earthquake" is: An earthquake of sufficient intensity such that: (a) the vibratory ground motion is felt at the nuclear plant site and recognized as an earthquake based on a consensus of Control Room operators on duty at the time, and (b) for plants with operable seismic instrumentation, the seismic switches of the plant are activated.</p> <p>The ETNA Seismograph Event Recorder Red LED indicator ON indicates an event has been recorded. The red LED indicator flashing indicates an event is being recorded or the device is writing to memory; I&C should be contacted immediately.</p> <p>The USGS National Earthquake Information Center can confirm if an earthquake has occurred in the area of the plant.</p> <p>Threshold #2</p> <p>This Threshold is based on a tornado striking (touching down) or high winds within the PROTECTED AREA.</p> <p>The high wind Threshold Value (100 mph) is based on approaching the FSAR design basis maximum wind speed value (145 mph) and is within the calibrated range of Control Room instrumentation. Escalation of this emergency classification level, if appropriate, would be based VISIBLE DAMAGE via HA1.</p> <p>Threshold #3</p> <p>This EAL addresses the effect of internal flooding caused by events such as component failures, equipment misalignment, or outage activity mishaps.</p> <p>Escalation of this emergency classification level, if appropriate, would be based VISIBLE DAMAGE via HA1, or by other plant conditions.</p> <p>Threshold #4</p> <p>This Threshold addresses main turbine rotating component failures of sufficient magnitude to cause observable damage to the turbine casing or to the seals of the turbine generator. Generator seal damage observed after generator purge does not meet the intent of this Threshold because it did not impact normal operation of the plant.</p> <p>Of major concern is the potential for leakage of combustible fluids (lubricating oils) and gases (hydrogen cooling) to the plant environs. Actual FIRES and flammable gas build up are appropriately classified via HU2 and HU3.</p> <p>This Threshold is consistent with the definition of a NOUE while maintaining the anticipatory nature desired and recognizing the risk to non-safety related equipment.</p> <p>Escalation of this emergency classification level, if appropriate, would be to HA1 based on damage done by PROJECTILES generated by the failure.</p> <p>Threshold #5</p> <p>This Threshold addresses natural phenomena for a hurricane and the associated storm surge that can also be precursors of more serious events.</p>
	<p>HA1 – Basis:</p> <p>These Thresholds escalate from HU1 in that the occurrence of the event has resulted in VISIBLE DAMAGE to plant structures or areas containing equipment necessary for a safe shutdown, or has caused damage to the safety systems in those structures evidenced by Control Room indications of degraded system response or performance.</p> <p>The occurrence of VISIBLE DAMAGE and/or degraded system response is intended to discriminate against lesser events. The initial report should not be interpreted as mandating a lengthy damage assessment prior to classification. No attempt is made in this Threshold to assess the actual magnitude of the damage. The significance here is not that a particular system or structure was damaged, but rather, that the event was of sufficient magnitude to cause this degradation.</p> <p>Escalation of this emergency classification level, if appropriate, would be based on System Malfunction (S).</p> <p>Threshold #1</p> <p>Seismic events of this magnitude can result in a VITAL AREA being subjected to forces beyond design basis. This includes, but is not limited to, the occurrence of a seismic event with Modified Mercalli Intensity V (0.04 – 0.09 g) is indicated by:</p> <ul style="list-style-type: none"> Felt by nearly everyone Light damage, some windows broken, or unstable objects overturned. <p>The ETNA Seismograph Event Recorder Red LED indicator ON indicates an event has been recorded. The red LED indicator flashing indicates an event is being recorded or the device is writing to memory; I&C should be contacted immediately.</p> <p>The USGS National Earthquake Information Center can confirm if an earthquake has occurred in the area of the plant.</p> <p>Threshold #2</p> <p>This Threshold is based on a tornado striking (touching down) or high winds that have caused VISIBLE DAMAGE to structures containing functions or systems required for safe shutdown of the plant.</p> <p>Threshold #3</p> <p>This Threshold addresses the effect of internal flooding caused by events such as component failures, equipment misalignment, or outage activity mishaps. It is based on the degraded performance of systems, or that has created industrial safety hazards (e.g., electrical shock) that preclude necessary access to operate or monitor safety equipment. The inability to access, operate, or monitor safety equipment represents an actual or substantial potential degradation of the level of safety of the plant.</p> <p>Flooding as used in this Threshold describes a condition where water is entering the room faster than installed equipment is capable of removal, resulting in a rise of water level within the room to isolate the water source.</p> <p>Threshold #5</p> <p>This Threshold addresses vehicle crashes within the PROTECTED AREA that results in VISIBLE DAMAGE to VITAL AREAS or indication of damage to safety structures, systems, or components containing functions and systems required for safe shutdown of the plant.</p> <p>Threshold #6</p> <p>This Threshold addresses other natural phenomena that result in VISIBLE DAMAGE to VITAL AREAS or results in indication of damage to safety structures, systems, or components containing functions and systems required for safe shutdown of the plant in the event of a hurricane and the associated storm surge that can also be precursors of more serious events.</p>	<p>Alert</p> <p>HA1 – Basis:</p> <p>These Thresholds escalate from HU1 in that the occurrence of the event has resulted in VISIBLE DAMAGE to plant structures or areas containing equipment necessary for a safe shutdown, or has caused damage to the safety systems in those structures evidenced by Control Room indications of degraded system response or performance.</p> <p>The occurrence of VISIBLE DAMAGE and/or degraded system response is intended to discriminate against lesser events. The initial report should not be interpreted as mandating a lengthy damage assessment prior to classification. No attempt is made in this Threshold to assess the actual magnitude of the damage. The significance here is not that a particular system or structure was damaged, but rather, that the event was of sufficient magnitude to cause this degradation.</p> <p>Escalation of this emergency classification level, if appropriate, would be based on System Malfunction (S).</p> <p>Threshold #1</p> <p>Seismic events of this magnitude can result in a VITAL AREA being subjected to forces beyond design basis. This includes, but is not limited to, the occurrence of a seismic event with Modified Mercalli Intensity V (0.04 – 0.09 g) is indicated by:</p> <ul style="list-style-type: none"> Felt by nearly everyone Light damage, some windows broken, or unstable objects overturned. <p>The ETNA Seismograph Event Recorder Red LED indicator ON indicates an event has been recorded. The red LED indicator flashing indicates an event is being recorded or the device is writing to memory; I&C should be contacted immediately.</p> <p>The USGS National Earthquake Information Center can confirm if an earthquake has occurred in the area of the plant.</p> <p>Threshold #2</p> <p>This Threshold is based on a tornado striking (touching down) or high winds that have caused VISIBLE DAMAGE to structures containing functions or systems required for safe shutdown of the plant.</p> <p>Threshold #3</p> <p>This Threshold addresses the effect of internal flooding caused by events such as component failures, equipment misalignment, or outage activity mishaps. It is based on the degraded performance of systems, or that has created industrial safety hazards (e.g., electrical shock) that preclude necessary access to operate or monitor safety equipment. The inability to access, operate, or monitor safety equipment represents an actual or substantial potential degradation of the level of safety of the plant.</p> <p>Flooding as used in this Threshold describes a condition where water is entering the room faster than installed equipment is capable of removal, resulting in a rise of water level within the room to isolate the water source.</p> <p>Threshold #5</p> <p>This Threshold addresses vehicle crashes within the PROTECTED AREA that results in VISIBLE DAMAGE to VITAL AREAS or indication of damage to safety structures, systems, or components containing functions and systems required for safe shutdown of the plant.</p> <p>Threshold #6</p> <p>This Threshold addresses other natural phenomena that result in VISIBLE DAMAGE to VITAL AREAS or results in indication of damage to safety structures, systems, or components containing functions and systems required for safe shutdown of the plant in the event of a hurricane and the associated storm surge that can also be precursors of more serious events.</p>	<p>Unusual Event</p> <p>HU1 – Basis:</p> <p>These Thresholds are categorized on the basis of the occurrence of an event of sufficient magnitude to be of concern to plant operators.</p> <p>Threshold #1</p> <p>Damage may be caused to some portions of the site, but should not affect ability of safety functions to operate. The Modified Mercalli Intensity IV (0.01 – 0.04 g) is indicated by:</p> <ul style="list-style-type: none"> Felt indoors by many, outdoors by few No damage <p>As defined in the EPRI-sponsored Guidelines for Nuclear Plant Response to an Earthquake, dated October 1989, a "felt earthquake" is: An earthquake of sufficient intensity such that: (a) the vibratory ground motion is felt at the nuclear plant site and recognized as an earthquake based on a consensus of Control Room operators on duty at the time, and (b) for plants with operable seismic instrumentation, the seismic switches of the plant are activated.</p> <p>The ETNA Seismograph Event Recorder Red LED indicator ON indicates an event has been recorded. The red LED indicator flashing indicates an event is being recorded or the device is writing to memory; I&C should be contacted immediately.</p> <p>The USGS National Earthquake Information Center can confirm if an earthquake has occurred in the area of the plant.</p> <p>Threshold #2</p> <p>This Threshold is based on a tornado striking (touching down) or high winds within the PROTECTED AREA.</p> <p>The high wind Threshold Value (100 mph) is based on approaching the FSAR design basis maximum wind speed value (145 mph) and is within the calibrated range of Control Room instrumentation. Escalation of this emergency classification level, if appropriate, would be based VISIBLE DAMAGE via HA1.</p> <p>Threshold #3</p> <p>This EAL addresses the effect of internal flooding caused by events such as component failures, equipment misalignment, or outage activity mishaps.</p> <p>Escalation of this emergency classification level, if appropriate, would be based VISIBLE DAMAGE via HA1, or by other plant conditions.</p> <p>Threshold #4</p> <p>This Threshold addresses main turbine rotating component failures of sufficient magnitude to cause observable damage to the turbine casing or to the seals of the turbine generator. Generator seal damage observed after generator purge does not meet the intent of this Threshold because it did not impact normal operation of the plant.</p> <p>Of major concern is the potential for leakage of combustible fluids (lubricating oils) and gases (hydrogen cooling) to the plant environs. Actual FIRES and flammable gas build up are appropriately classified via HU2 and HU3.</p> <p>This Threshold is consistent with the definition of a NOUE while maintaining the anticipatory nature desired and recognizing the risk to non-safety related equipment.</p> <p>Escalation of this emergency classification level, if appropriate, would be to HA1 based on damage done by PROJECTILES generated by the failure.</p> <p>Threshold #5</p> <p>This Threshold addresses natural phenomena for a hurricane and the associated storm surge that can also be precursors of more serious events.</p>

Site Area Emergency

DEFINITION BOX

EXPLOSION – A rapid, violent, unconfined combustion, or catastrophic failure of pressurized/energized equipment that imparts energy of sufficient force to potentially damage permanent structures, systems, or components.

FIRE – Combustion characterized by heat and light. Sources of smoke such as slipping drive belts or overheated electrical equipment do not constitute FIRES. Observation of flame is preferred but is NOT required if large quantities of smoke and heat are observed.

NORMAL PLANT OPERATIONS – Activities at the plant site associated with routine testing, maintenance, or equipment operations, in accordance with normal operating or administrative procedures. Entry into abnormal or emergency operating procedures, or deviation from normal security or radiological control posture, is a departure from NORMAL PLANT OPERATIONS.

PROJECTILE – An object directed toward a Nuclear Power Plant (NPP) that could cause concern for its continued operability, reliability, or personnel safety.

PROTECTED AREA – The area (within the Owner Controlled Area) occupied by the nuclear units and associated equipment and facilities enclosed within the security perimeter fence. The area within which accountability of personnel is maintained in an emergency. This does not include the SFES Protected Area.

VISIBLE DAMAGE – Damage to equipment or structure that is readily observable without measurements, testing, or analysis. Damage is sufficient to cause concern regarding the continued operability or reliability of the affected structure, system, or component. Example damage includes: deformation due to heat or impact, denting, penetration, rupture, cracking, and paint blistering. Surface blemishes (e.g., paint chipping, scratches) should not be included.

VITAL AREAS – Areas within the PROTECTED AREA, that contain equipment, systems, components, or material, the failure, destruction, or release of which could directly or indirectly endanger the public health and safety by exposure to radiation.

Alert

HA1 Natural or Destructive Phenomena Affecting VITAL AREAS.

Operating Mode Applicability: All

Threshold Values:

- a. Earthquake confirmed by ANY of the following:
 - Earthquake felt in plant
 - Modified Mercalli intensity V evaluated
 - USGS National Earthquake Information Center
- AND
- b. Control Room indication of degraded performance of systems required for the safe shutdown of the plant.

OR
- c. Seismic event greater than Operating Basic Earthquake (OBE) as indicated by the ETNA Seismograph Event Recorder indicating greater than or equal to 0.05 g.

OR
2. Tornado striking OR high winds greater than 100 mph resulting in VISIBLE DAMAGE to ANY of the Table H1 plant structures containing safety systems or components OR Control Room indication of degraded performance of those safety systems.

OR
3. Internal flooding in the RHR Pump Rooms resulting in an electrical shock hazard that precludes access to operate or monitor safety equipment OR Control Room indication of degraded performance of those safety systems.

OR
4. Turbine failure-generated PROJECTILES resulting in VISIBLE DAMAGE to or penetration of ANY of the Table H1 plant structures containing safety systems or components OR Control Room indication of degraded performance of those safety systems.

OR
5. Vehicle crash resulting in VISIBLE DAMAGE to ANY of the Table H1 plant structures containing safety systems or components OR Control Room indication of degraded performance of those safety systems.

OR
6. Natural occurrences resulting in VISIBLE DAMAGE to ANY of the Table H1 plant structures containing safety systems or components OR Control Room indication of degraded performance of those safety systems.

TABLE H1

Turbine Building	Feedwater Platforms
Control Building/Roof	Condensate Storage Tanks
EDG Buildings	U3 DOST
Containment Buildings	Spent Fuel Areas
Primary Building/Roof	Charged Cooling Water Area
X-25 Buildings and 74 ELC	Fuel Handling Building
DWS EXHAUSTS	Main/Aux/Startup XFMRS
Main/Aux/Startup XFMRS	Refueling Water Storage Tanks
U4 Laydown Area	Primary Water Storage Tanks
Main Steam Platforms	Intake

Unusual Event

HU1 Natural or Destructive Phenomena Affecting the PROTECTED AREA.

Operating Mode Applicability: All

Threshold Value:

1. Seismic event identified by ANY 2 of the following:
 - Seismic event confirmed by the ETNA Seismograph Event Recorder Red LED Indicator ON.
 - Earthquake felt in plant
 - Modified Mercalli intensity IV evaluated
 - USGS National Earthquake Information Center

OR
2. Tornado striking within PROTECTED AREA boundary or high winds greater than 100 mph.

OR
3. Internal flooding in the RHR Pump Rooms that has the potential to affect safety related equipment required by Technical Specifications for the current operating mode.

OR
4. Turbine failure resulting in casing penetration or damage to turbine or generator seals.

OR
5. Natural occurrences affecting the PROTECTED AREA.
 - Confirmed hurricane warning is in effect.
 - Flood surge that prevents land access to the site

H – HAZARDS AND OTHER CONDITIONS AFFECTING PLANT SAFETY

NATURAL OR MAN-MADE EVENTS

Recognition Category

Rec. Cat.	Site Area Emergency	Alert	Unusual Event
H - HAZARDS AND OTHER CONDITIONS AFFECTING PLANT SAFETY	<p>DEFINITION BOX</p> <p>EXPLOSION - A rapid, violent, unconfined combustion, or catastrophic failure of pressurized/energized equipment that imparts energy of sufficient force to potentially damage permanent structures, systems, or components.</p> <p>FIRE - Combustion characterized by heat and light. Sources of smoke such as slipping drive belts or overheated electrical equipment do not constitute FIRES. Observation of flame is preferred but is NOT required if large quantities of smoke and heat are observed.</p> <p>NORMAL PLANT OPERATIONS - Activities at the plant site associated with routine testing, maintenance, or equipment operations, in accordance with normal operating or administrative procedures. Entry into abnormal or emergency operating procedures, or deviation from normal security or radiological controls posture, is a departure from NORMAL PLANT OPERATIONS.</p> <p>PROJECTILE - An object directed toward a Nuclear Power Plant (NPP) that could cause concern for its continued operability, reliability, or personnel safety.</p> <p>PROTECTED AREA - The area (within the Owner Controlled Area) occupied by the nuclear units and associated equipment and facilities enclosed within the security perimeter fences. The area within which accountability of personnel is maintained in an emergency. This does not include the ISFSI Protected Area.</p> <p>VISIBLE DAMAGE - Damage to equipment or structure that is readily observable without measurements, testing, or analysis. Damage is sufficient to cause concern regarding the continued operability or reliability of the affected structure, system, or component. Example damage includes: deformation due to heat or impact; denting; penetration; rupture, cracking, and paint blistering. Surface blemishes (e.g., paint chipping, scratches) should not be included.</p> <p>VITAL AREAS - Areas within the PROTECTED AREA, that contains equipment, systems, components, or material, the failure, destruction, or release of which could directly or indirectly endanger the public health and safety by exposure to radiation.</p>	<p>HA2 - Basis:</p> <p>VISIBLE DAMAGE is used to identify the magnitude of the FIRE or EXPLOSION included to discriminate against minor FIRES and EXPLOSIONS.</p> <p>The reference to structures containing safety systems or components is included to discriminate against FIRES or EXPLOSIONS in areas having a low probability of affecting safe operation. The significance here is not that a safety system was degraded but the fact that the FIRE or EXPLOSION was large enough to cause damage to these systems.</p> <p>The use of VISIBLE DAMAGE should not be interpreted as mandating a lengthy damage assessment prior to classification. The declaration of an Alert and the activation of the Technical Support Center will provide the Emergency Coordinator with the resources needed to perform detailed damage assessments.</p> <p>The Emergency Coordinator also needs to consider any security aspects of the EXPLOSION.</p> <p>Escalation of this emergency classification level, if appropriate, will be based on System Malfunctions, Fission Product Barrier Degradation or Abnormal Rad Levels / Radiological Effluent ICS.</p> <p>HA3 - Basis:</p> <p>Gases in a VITAL AREA can affect the ability to safely operate or safely shutdown the reactor.</p> <p>The fact that SCBA may be worn does not eliminate the need to declare the event.</p> <p>Declaration should not be delayed for confirmation from atmospheric testing if the atmosphere poses an immediate threat to life and health or an immediate hazard to plant operations. It could be based upon documented analysis, indication of personnel effects from exposure, or operating experience with the hazards.</p> <p>If the equipment in the stated area was already inoperable, or out of service, before the event occurred, then this EAL should not be declared as it will have no adverse impact on the ability of the plant to safely operate or safely shutdown beyond that already allowed by Technical Specifications at the time of the event.</p> <p>An asphyxiant is a gas capable of reducing the level of oxygen in the body to dangerous levels. Most commonly, asphyxiants work by merely displacing air in an enclosed environment. This reduces the concentration of oxygen below the normal level of around 19%, which can lead to breathing difficulties, unconsciousness, or even death.</p> <p>An uncontrolled release of flammable gasses within a facility structure has the potential to affect safe operation of the plant by limiting either operator or equipment operations due to the potential for ignition and resulting equipment damage/personnel injury. Flammable gasses, such as hydrogen and acetylene, are routinely used to maintain plant systems (hydrogen) or to repair equipment/components (acetylene - used in welding). This Threshold assumes concentrations of flammable gasses which can ignite/support combustion.</p> <p>Escalation of this emergency classification level, if appropriate, will be based on System Malfunctions, Fission Product Barrier Degradation or Abnormal Rad Levels / Radiological Effluent ICS.</p>	<p>HA2 - Basis:</p> <p>This Threshold addresses the magnitude and extent of FIRES or EXPLOSIONS that may be potentially significant precursors of damage to safety systems. It addresses the FIRE / EXPLOSION, and not the degradation in performance of affected systems that may result.</p> <p>As used here, detection is visual observation and report by plant personnel or sensor alarm indication.</p> <p>Threshold #1</p> <p>The 15 minute time period begins with a credible notification that a FIRE is occurring, or indication of a fire detection system alarm/actuation. Verification of a fire detection system alarm/actuation includes actions that can be taken within the Control Room or directly on site to ensure that it is not spurious. An alarm is assumed to be an indication of a FIRE in the area of the alarm. An alarm may be verified by being dispatched to the scene. In other words, a personnel report from the scene may be used to disprove a sensor alarm if received within 15 minutes of the alarm, but shall not be required to verify the alarm.</p> <p>The intent of this 15 minute duration is to size the FIRE and to discriminate against small FIRES that are readily extinguished (e.g., smoldering waste paper basket).</p> <p>Threshold #2</p> <p>This Threshold addresses only those EXPLOSIONS of sufficient force to damage permanent structures or equipment within the PROTECTED AREA.</p> <p>No attempt is made to assess the actual magnitude of the damage. The occurrence of the EXPLOSION is sufficient for declaration.</p> <p>The Emergency Coordinator also needs to consider any security aspects of the EXPLOSION, if applicable.</p> <p>Escalation of this emergency classification level, if appropriate, would be based on HAZ.</p> <p>HA3 - Basis:</p> <p>This Threshold is based on the release of toxic, corrosive, asphyxiant, or flammable gases of sufficient quantity to affect NORMAL PLANT OPERATIONS.</p> <p>The fact that SCBA may be worn does not eliminate the need to declare the event.</p> <p>This IC is not intended to require significant assessment or quantification. It assumes an uncontrolled process that has the potential to affect plant operations. This would preclude small or incidental releases, or releases that do not impact structures needed for plant operation.</p> <p>An asphyxiant is a gas capable of reducing the level of oxygen in the body to dangerous levels. Most commonly, asphyxiants work by merely displacing air in an enclosed environment. This reduces the concentration of oxygen below the normal level of around 19%, which can lead to breathing difficulties, unconsciousness, or even death.</p> <p>Escalation of this emergency classification level, if appropriate, would be based on HAZ.</p>

DEFINITION BOX		Recognition Category																																									
<p>EXPLOSION – A rapid, violent, unconfined combustion, or catastrophic failure of pressurized/energized equipment that imparts energy of sufficient force to potentially damage permanent structures, systems, or components.</p> <p>FIRE – Combustion characterized by heat and light. Sources of smoke such as slipping drive belts or overheated electrical equipment do not constitute fires. Observation of flame is preferred but is NOT required if large quantities of smoke and heat are observed.</p> <p>NORMAL PLANT OPERATIONS – Activities at the plant site associated with routine testing, maintenance, or equipment operations, in accordance with normal operating or administrative procedures. Entry into abnormal or emergency operating procedures, or deviation from normal security or radiological controls posture, is a departure from NORMAL PLANT OPERATIONS.</p> <p>PROJECTILE – An object directed toward a Nuclear Power Plant (NPP) that could cause concern for its continued operability, reliability, or personnel safety.</p> <p>PROTECTED AREA – The area (within the Owner Controlled Area) occupied by the nuclear units and associated equipment and facilities enclosed within the security perimeter fence. The area within which accountability of personnel is maintained in an emergency. This does not include the ISFSI Protected Area.</p> <p>VISIBLE DAMAGE – Damage to equipment or structure that is readily observable without measurements, testing, or analysis. Damage is sufficient to cause concern regarding the continued operability or reliability of the affected structure, system, or component. Example damage includes: deformation due to heat or impact, denting, penetration, rupture, cracking, and paint blistering. Surface blemishes (e.g., paint chipping, scratches) should not be included.</p> <p>VITAL AREAS – Areas within the PROTECTED AREA, that contains equipment, systems, components, or material, the failure, destruction, or release of which could directly or indirectly endanger the public health and safety by exposure to radiation.</p>		<p>H – HAZARDS AND OTHER CONDITIONS AFFECTING PLANT SAFETY</p>																																									
<p>Site Area Emergency</p>		<p>Unusual Event</p>																																									
<p>HAZ FIRE or EXPLOSION Affecting the Operability of Plant Safety Systems Required to Establish or Maintain Safe Shutdown.</p> <p>Operating Mode Applicability: All</p> <p>Threshold Value:</p> <p>1. FIRE or EXPLOSION resulting in VISIBLE DAMAGE to ANY of the following structures containing safety systems or components OR Control Room indication of degraded performance of those safety systems.</p> <table border="1"> <tr><td>Turbine Building</td><td>Feedwater Platforms</td></tr> <tr><td>Control Building/Roof</td><td>Condensate Storage Tanks</td></tr> <tr><td>EDG Buildings</td><td>U3 DOST</td></tr> <tr><td>Containment Buildings</td><td>Spent Fuel Areas</td></tr> <tr><td>Auxiliary Building/Roof</td><td>Component Cooling Water Area</td></tr> <tr><td>3/4 C Bus/XFMRs and 3/4 E LC</td><td>HHST Pump Area</td></tr> <tr><td>DWST</td><td>Fuel Handling Building</td></tr> <tr><td>Main/Aux/Startup XFMRs</td><td>Refueling Water Storage Tanks</td></tr> <tr><td>U4 Laydown Area</td><td>Primary Water Storage Tanks</td></tr> <tr><td>Main Steam Platforms</td><td>Intake</td></tr> </table>		Turbine Building	Feedwater Platforms	Control Building/Roof	Condensate Storage Tanks	EDG Buildings	U3 DOST	Containment Buildings	Spent Fuel Areas	Auxiliary Building/Roof	Component Cooling Water Area	3/4 C Bus/XFMRs and 3/4 E LC	HHST Pump Area	DWST	Fuel Handling Building	Main/Aux/Startup XFMRs	Refueling Water Storage Tanks	U4 Laydown Area	Primary Water Storage Tanks	Main Steam Platforms	Intake	<p>HU2 FIRE Within the PROTECTED AREA Not Extinguished Within 15 Minutes of Detection OR EXPLOSION within the PROTECTED AREA.</p> <p>Operating Mode Applicability: All</p> <p>Threshold Value:</p> <p>Note: The Emergency Coordinator should not wait until the applicable time has elapsed, but should declare the event as soon as it is determined that the duration has exceeded, or will likely exceed, the applicable time.</p> <p>1. FIRE in any of the following areas not extinguished within 15 minutes of a FIRE Alarm or Control Room notification.</p> <table border="1"> <tr><td>Turbine Building</td><td>Feedwater Platforms</td></tr> <tr><td>Control Building/Roof</td><td>Condensate Storage Tanks</td></tr> <tr><td>EDG Buildings</td><td>U3 DOST</td></tr> <tr><td>Containment Buildings</td><td>Spent Fuel Areas</td></tr> <tr><td>Auxiliary Building/Roof</td><td>Component Cooling Water Area</td></tr> <tr><td>3/4 C Bus/XFMRs and 3/4 E LC</td><td>HHST Pump Area</td></tr> <tr><td>DWST</td><td>Fuel Handling Building</td></tr> <tr><td>Main/Aux/Startup XFMRs</td><td>Refueling Water Storage Tanks</td></tr> <tr><td>U4 Laydown Area</td><td>Primary Water Storage Tanks</td></tr> <tr><td>Main Steam Platforms</td><td>Intake</td></tr> </table>		Turbine Building	Feedwater Platforms	Control Building/Roof	Condensate Storage Tanks	EDG Buildings	U3 DOST	Containment Buildings	Spent Fuel Areas	Auxiliary Building/Roof	Component Cooling Water Area	3/4 C Bus/XFMRs and 3/4 E LC	HHST Pump Area	DWST	Fuel Handling Building	Main/Aux/Startup XFMRs	Refueling Water Storage Tanks	U4 Laydown Area	Primary Water Storage Tanks	Main Steam Platforms	Intake
Turbine Building	Feedwater Platforms																																										
Control Building/Roof	Condensate Storage Tanks																																										
EDG Buildings	U3 DOST																																										
Containment Buildings	Spent Fuel Areas																																										
Auxiliary Building/Roof	Component Cooling Water Area																																										
3/4 C Bus/XFMRs and 3/4 E LC	HHST Pump Area																																										
DWST	Fuel Handling Building																																										
Main/Aux/Startup XFMRs	Refueling Water Storage Tanks																																										
U4 Laydown Area	Primary Water Storage Tanks																																										
Main Steam Platforms	Intake																																										
Turbine Building	Feedwater Platforms																																										
Control Building/Roof	Condensate Storage Tanks																																										
EDG Buildings	U3 DOST																																										
Containment Buildings	Spent Fuel Areas																																										
Auxiliary Building/Roof	Component Cooling Water Area																																										
3/4 C Bus/XFMRs and 3/4 E LC	HHST Pump Area																																										
DWST	Fuel Handling Building																																										
Main/Aux/Startup XFMRs	Refueling Water Storage Tanks																																										
U4 Laydown Area	Primary Water Storage Tanks																																										
Main Steam Platforms	Intake																																										
<p>HA3 Access to a VITAL AREA is Prohibited Due To Toxic, Corrosive, Asphyxiant or Flammable Gases Which Jeopardize Operation of Operable Equipment Required to Maintain Safe Operations or Safely Shutdown the Reactor.</p> <p>Operating Mode Applicability: All</p> <p>Threshold Values:</p> <p>Note: If the equipment in the stated area was already inoperable or out of service before the event occurred, then this EAL should not be declared as it will have no adverse impact on the ability of the plant to safely operate or safely shutdown beyond that already allowed by Technical Specifications at the time of the event.</p> <p>1. Access to a VITAL AREA is prohibited due to toxic, corrosive, asphyxiant, or flammable gases which jeopardize operation of systems required to maintain safe operations or safely shutdown the reactor.</p>		<p>HU3 Release of Toxic, Corrosive, Asphyxiant, or Flammable Gases Deemed Detrimental to NORMAL PLANT OPERATIONS.</p> <p>Operating Mode Applicability: All</p> <p>Threshold Values:</p> <p>1. Toxic, corrosive, asphyxiant, or flammable gases in amounts that have or could adversely affect NORMAL PLANT OPERATIONS.</p> <p>2. Report by local, county or state officials for evacuation or sheltering of site personnel based on an off-site event.</p>																																									
<p>GUIDANCE BOX FOR HU3, HA3</p> <p>Planned controlled activities, such as Containment entry at power, do not meet the intent of HU3 or HA3.</p>		<p>FIRE / EXPLOSION</p>																																									
<p>TOXIC / FLAMMABLE GAS</p>		<p>TOXIC / FLAMMABLE GAS</p>																																									

H - HAZARDS AND OTHER CONDITIONS AFFECTING PLANT SAFETY

Rec. Cat.	HGI - Basis:	Site Area Emergency	Alert	Unusual Event
<p>HGI - Basis:</p> <p>Threshold #1</p> <p>This Threshold encompasses conditions under which a HOSTILE ACTION has resulted in a loss of physical control of VITAL AREAS (containing vital equipment or controls of vital equipment) required to maintain safety functions at another location.</p> <p>These safety functions are reactivity control, RCS inventory, and secondary heat removal.</p> <p>If control of the plant equipment necessary to maintain safety functions can be transferred to another location, then the threshold is not met.</p> <p>Threshold #2</p> <p>This Threshold addresses failure of Spent Fuel Cooling Systems as a result of HOSTILE ACTION if IMMINENT fuel damage is likely, such as when a freshly off-loaded reactor core is in the spent fuel pool.</p>	<p>HSA - Basis:</p> <p>This condition represents an escalated threat to plant safety above that contained in the Alert in that a HOSTILE FORCE has progressed from the OWNER CONTROLLED AREA to the PROTECTED AREA.</p> <p>This Threshold addresses the contingency for a very rapid progression of events, such as that experienced on September 11, 2001. It is not premised solely on the potential for a radiological release. Rather the issue includes the need for rapid assistance due to the possibility for significant and indeterminate damage from additional air, land, or water attack elements.</p> <p>The fact that the site is under serious attack with minimal time available for further preparation or additional assistance to arrive at the site is a condition that can be effective (such as on-site evacuation, disposal or sheltering).</p> <p>Threshold #1</p> <p>This Threshold addresses the potential for a very rapid progression of events due to a HOSTILE ACTION. It is not intended to address incidents that are accidental events or acts of civil disobedience, such as small aircraft impact, hijackers, or physical disputes between employees within the OCA. Those events are adequately addressed by other EALs.</p> <p>Note that this EAL is applicable for any HOSTILE ACTION occurring, or that has occurred, in the OWNER CONTROLLED AREA. This includes ISFSIs that may be outside the PROTECTED AREA but still within the OWNER CONTROLLED AREA.</p> <p>Threshold #2</p> <p>This Threshold addresses the immediacy of an expected threat arrival or impact on the site within a relatively short time.</p> <p>The intent of this Threshold is to ensure that notifications for the AIRLINER attack threat are made in a timely manner and that OROs and plant personnel are at a state of heightened awareness regarding the credible threat. AIRLINER is meant to be a large aircraft with the potential for causing significant damage to the plant.</p> <p>This Threshold is met when a plant receives information regarding an AIRLINER attack threat from NRC and the airliner is within 30 minutes of the plant. Only the plant to which the specific threat is made need declare the Alert.</p> <p>The NRC Headquarters Operations Officer (HOO) will communicate to the licensee if the threat involves an AIRLINER (AIRLINER is meant to be a large aircraft with the potential for causing significant damage to the plant). The status and size of the plane may be provided by NORAD through the NRC.</p>	<p>HA4 - Basis:</p> <p>Note:</p> <p>These Thresholds address the contingency for a very rapid progression of events, such as that experienced on September 11, 2001. They are not premised solely on the potential for a radiological release. Rather the issue includes the need for rapid assistance due to the possibility for significant and indeterminate damage from additional air, land, or water attack elements.</p> <p>The fact that the site is under serious attack or is an identified attack target with minimal time available for further preparation or additional assistance to arrive at the site is a condition that can be effective (such as on-site evacuation, disposal or sheltering).</p> <p>Threshold #1</p> <p>This Threshold addresses the potential for a very rapid progression of events due to a HOSTILE ACTION. It is not intended to address incidents that are accidental events or acts of civil disobedience, such as small aircraft impact, hijackers, or physical disputes between employees within the OCA. Those events are adequately addressed by other EALs.</p> <p>Note that this EAL is applicable for any HOSTILE ACTION occurring, or that has occurred, in the OWNER CONTROLLED AREA. This includes ISFSIs that may be outside the PROTECTED AREA but still within the OWNER CONTROLLED AREA.</p> <p>Threshold #2</p> <p>This Threshold addresses the immediacy of an expected threat arrival or impact on the site within a relatively short time.</p> <p>The intent of this Threshold is to ensure that notifications for the AIRLINER attack threat are made in a timely manner and that OROs and plant personnel are at a state of heightened awareness regarding the credible threat. AIRLINER is meant to be a large aircraft with the potential for causing significant damage to the plant.</p> <p>This Threshold is met when a plant receives information regarding an AIRLINER attack threat from NRC and the airliner is within 30 minutes of the plant. Only the plant to which the specific threat is made need declare the Alert.</p> <p>The NRC Headquarters Operations Officer (HOO) will communicate to the licensee if the threat involves an AIRLINER (AIRLINER is meant to be a large aircraft with the potential for causing significant damage to the plant). The status and size of the plane may be provided by NORAD through the NRC.</p>	<p>HA5 - Basis:</p> <p>With the Control Room evacuated, additional support, monitoring, and direction through the Technical Support Center and/or other emergency response facilities may be necessary.</p> <p>Inability to establish plant control from outside the Control Room will escalate this event to a Site Area Emergency.</p>	
<p>HG1 - Basis:</p> <p>This Threshold encompasses conditions under which a HOSTILE ACTION has resulted in a loss of physical control of VITAL AREAS (containing vital equipment or controls of vital equipment) required to maintain safety functions at another location.</p> <p>These safety functions are reactivity control, RCS inventory, and secondary heat removal.</p> <p>If control of the plant equipment necessary to maintain safety functions can be transferred to another location, then the threshold is not met.</p> <p>Threshold #2</p> <p>This Threshold addresses failure of Spent Fuel Cooling Systems as a result of HOSTILE ACTION if IMMINENT fuel damage is likely, such as when a freshly off-loaded reactor core is in the spent fuel pool.</p>	<p>HS2 - Basis:</p> <p>The intent of this (C) is to capture those events where control of the plant cannot be reestablished in a timely manner, in this case, expeditious transfer of control of safety systems has not occurred (although fission product barrier damage may not yet be indicated).</p> <p>The intent of the Threshold is to establish control of important plant equipment (such as emergency generators) in a timely manner. Primary emphasis should be placed on the status and instruments that supply protection for and information about safety functions.</p> <p>These safety functions are reactivity control, RCS inventory, and secondary heat removal.</p> <p>The determination of whether or not control is established at the remote shutdown panel is based on Emergency Coordinator judgment. The Emergency Coordinator is expected to make a reasonable, informed judgment within the time for transfer that the licensee has control of the plant from the remote shutdown panel.</p> <p>Escalation of the emergency classification level, if appropriate, would be by Fission Product Barrier Degradation or Abnormal Rad Levels/Radiological Effluent EALs.</p>	<p>HA4 - Basis:</p> <p>Note:</p> <p>These Thresholds address the contingency for a very rapid progression of events, such as that experienced on September 11, 2001. They are not premised solely on the potential for a radiological release. Rather the issue includes the need for rapid assistance due to the possibility for significant and indeterminate damage from additional air, land, or water attack elements.</p> <p>The fact that the site is under serious attack with minimal time available for further preparation or additional assistance to arrive at the site is a condition that can be effective (such as on-site evacuation, disposal or sheltering).</p> <p>Threshold #1</p> <p>This Threshold addresses the potential for a very rapid progression of events due to a HOSTILE ACTION. It is not intended to address incidents that are accidental events or acts of civil disobedience, such as small aircraft impact, hijackers, or physical disputes between employees within the OCA. Those events are adequately addressed by other EALs.</p> <p>Note that this EAL is applicable for any HOSTILE ACTION occurring, or that has occurred, in the OWNER CONTROLLED AREA. This includes ISFSIs that may be outside the PROTECTED AREA but still within the OWNER CONTROLLED AREA.</p> <p>Threshold #2</p> <p>This Threshold addresses the immediacy of an expected threat arrival or impact on the site within a relatively short time.</p> <p>The intent of this Threshold is to ensure that notifications for the AIRLINER attack threat are made in a timely manner and that OROs and plant personnel are at a state of heightened awareness regarding the credible threat. AIRLINER is meant to be a large aircraft with the potential for causing significant damage to the plant.</p> <p>This Threshold is met when a plant receives information regarding an AIRLINER attack threat from NRC and the airliner is within 30 minutes of the plant. Only the plant to which the specific threat is made need declare the Alert.</p> <p>The NRC Headquarters Operations Officer (HOO) will communicate to the licensee if the threat involves an AIRLINER (AIRLINER is meant to be a large aircraft with the potential for causing significant damage to the plant). The status and size of the plane may be provided by NORAD through the NRC.</p>	<p>HA5 - Basis:</p> <p>With the Control Room evacuated, additional support, monitoring, and direction through the Technical Support Center and/or other emergency response facilities may be necessary.</p> <p>Inability to establish plant control from outside the Control Room will escalate this event to a Site Area Emergency.</p>	
<p>HG1 - Basis:</p> <p>This Threshold encompasses conditions under which a HOSTILE ACTION has resulted in a loss of physical control of VITAL AREAS (containing vital equipment or controls of vital equipment) required to maintain safety functions at another location.</p> <p>These safety functions are reactivity control, RCS inventory, and secondary heat removal.</p> <p>If control of the plant equipment necessary to maintain safety functions can be transferred to another location, then the threshold is not met.</p> <p>Threshold #2</p> <p>This Threshold addresses failure of Spent Fuel Cooling Systems as a result of HOSTILE ACTION if IMMINENT fuel damage is likely, such as when a freshly off-loaded reactor core is in the spent fuel pool.</p>	<p>HS2 - Basis:</p> <p>The intent of this (C) is to capture those events where control of the plant cannot be reestablished in a timely manner, in this case, expeditious transfer of control of safety systems has not occurred (although fission product barrier damage may not yet be indicated).</p> <p>The intent of the Threshold is to establish control of important plant equipment (such as emergency generators) in a timely manner. Primary emphasis should be placed on the status and instruments that supply protection for and information about safety functions.</p> <p>These safety functions are reactivity control, RCS inventory, and secondary heat removal.</p> <p>The determination of whether or not control is established at the remote shutdown panel is based on Emergency Coordinator judgment. The Emergency Coordinator is expected to make a reasonable, informed judgment within the time for transfer that the licensee has control of the plant from the remote shutdown panel.</p> <p>Escalation of the emergency classification level, if appropriate, would be by Fission Product Barrier Degradation or Abnormal Rad Levels/Radiological Effluent EALs.</p>	<p>HA4 - Basis:</p> <p>Note:</p> <p>These Thresholds address the contingency for a very rapid progression of events, such as that experienced on September 11, 2001. They are not premised solely on the potential for a radiological release. Rather the issue includes the need for rapid assistance due to the possibility for significant and indeterminate damage from additional air, land, or water attack elements.</p> <p>The fact that the site is under serious attack with minimal time available for further preparation or additional assistance to arrive at the site is a condition that can be effective (such as on-site evacuation, disposal or sheltering).</p> <p>Threshold #1</p> <p>This Threshold addresses the potential for a very rapid progression of events due to a HOSTILE ACTION. It is not intended to address incidents that are accidental events or acts of civil disobedience, such as small aircraft impact, hijackers, or physical disputes between employees within the OCA. Those events are adequately addressed by other EALs.</p> <p>Note that this EAL is applicable for any HOSTILE ACTION occurring, or that has occurred, in the OWNER CONTROLLED AREA. This includes ISFSIs that may be outside the PROTECTED AREA but still within the OWNER CONTROLLED AREA.</p> <p>Threshold #2</p> <p>This Threshold addresses the immediacy of an expected threat arrival or impact on the site within a relatively short time.</p> <p>The intent of this Threshold is to ensure that notifications for the AIRLINER attack threat are made in a timely manner and that OROs and plant personnel are at a state of heightened awareness regarding the credible threat. AIRLINER is meant to be a large aircraft with the potential for causing significant damage to the plant.</p> <p>This Threshold is met when a plant receives information regarding an AIRLINER attack threat from NRC and the airliner is within 30 minutes of the plant. Only the plant to which the specific threat is made need declare the Alert.</p> <p>The NRC Headquarters Operations Officer (HOO) will communicate to the licensee if the threat involves an AIRLINER (AIRLINER is meant to be a large aircraft with the potential for causing significant damage to the plant). The status and size of the plane may be provided by NORAD through the NRC.</p>	<p>HA5 - Basis:</p> <p>With the Control Room evacuated, additional support, monitoring, and direction through the Technical Support Center and/or other emergency response facilities may be necessary.</p> <p>Inability to establish plant control from outside the Control Room will escalate this event to a Site Area Emergency.</p>	
<p>HG1 - Basis:</p> <p>This Threshold encompasses conditions under which a HOSTILE ACTION has resulted in a loss of physical control of VITAL AREAS (containing vital equipment or controls of vital equipment) required to maintain safety functions at another location.</p> <p>These safety functions are reactivity control, RCS inventory, and secondary heat removal.</p> <p>If control of the plant equipment necessary to maintain safety functions can be transferred to another location, then the threshold is not met.</p> <p>Threshold #2</p> <p>This Threshold addresses failure of Spent Fuel Cooling Systems as a result of HOSTILE ACTION if IMMINENT fuel damage is likely, such as when a freshly off-loaded reactor core is in the spent fuel pool.</p>	<p>HS2 - Basis:</p> <p>The intent of this (C) is to capture those events where control of the plant cannot be reestablished in a timely manner, in this case, expeditious transfer of control of safety systems has not occurred (although fission product barrier damage may not yet be indicated).</p> <p>The intent of the Threshold is to establish control of important plant equipment (such as emergency generators) in a timely manner. Primary emphasis should be placed on the status and instruments that supply protection for and information about safety functions.</p> <p>These safety functions are reactivity control, RCS inventory, and secondary heat removal.</p> <p>The determination of whether or not control is established at the remote shutdown panel is based on Emergency Coordinator judgment. The Emergency Coordinator is expected to make a reasonable, informed judgment within the time for transfer that the licensee has control of the plant from the remote shutdown panel.</p> <p>Escalation of the emergency classification level, if appropriate, would be by Fission Product Barrier Degradation or Abnormal Rad Levels/Radiological Effluent EALs.</p>	<p>HA4 - Basis:</p> <p>Note:</p> <p>These Thresholds address the contingency for a very rapid progression of events, such as that experienced on September 11, 2001. They are not premised solely on the potential for a radiological release. Rather the issue includes the need for rapid assistance due to the possibility for significant and indeterminate damage from additional air, land, or water attack elements.</p> <p>The fact that the site is under serious attack with minimal time available for further preparation or additional assistance to arrive at the site is a condition that can be effective (such as on-site evacuation, disposal or sheltering).</p> <p>Threshold #1</p> <p>This Threshold addresses the potential for a very rapid progression of events due to a HOSTILE ACTION. It is not intended to address incidents that are accidental events or acts of civil disobedience, such as small aircraft impact, hijackers, or physical disputes between employees within the OCA. Those events are adequately addressed by other EALs.</p> <p>Note that this EAL is applicable for any HOSTILE ACTION occurring, or that has occurred, in the OWNER CONTROLLED AREA. This includes ISFSIs that may be outside the PROTECTED AREA but still within the OWNER CONTROLLED AREA.</p> <p>Threshold #2</p> <p>This Threshold addresses the immediacy of an expected threat arrival or impact on the site within a relatively short time.</p> <p>The intent of this Threshold is to ensure that notifications for the AIRLINER attack threat are made in a timely manner and that OROs and plant personnel are at a state of heightened awareness regarding the credible threat. AIRLINER is meant to be a large aircraft with the potential for causing significant damage to the plant.</p> <p>This Threshold is met when a plant receives information regarding an AIRLINER attack threat from NRC and the airliner is within 30 minutes of the plant. Only the plant to which the specific threat is made need declare the Alert.</p> <p>The NRC Headquarters Operations Officer (HOO) will communicate to the licensee if the threat involves an AIRLINER (AIRLINER is meant to be a large aircraft with the potential for causing significant damage to the plant). The status and size of the plane may be provided by NORAD through the NRC.</p>	<p>HA5 - Basis:</p> <p>With the Control Room evacuated, additional support, monitoring, and direction through the Technical Support Center and/or other emergency response facilities may be necessary.</p> <p>Inability to establish plant control from outside the Control Room will escalate this event to a Site Area Emergency.</p>	

Recognition Category		H – HAZARDS AND OTHER CONDITIONS AFFECTING PLANT SAFETY	
<p>HG1 HOSTILE ACTION Resulting in Loss of Physical Control of the Facility.</p> <p>Operating Mode Applicability: All</p> <p>Threshold Value:</p> <ol style="list-style-type: none"> A HOSTILE ACTION has occurred such that plant personnel are unable to operate any equipment required to maintain safety functions. <p>OR</p> <ol style="list-style-type: none"> A HOSTILE ACTION has caused failure of Spent Fuel Cooling Systems and IMMINENT fuel damage is likely for a FRESHLY OFF-LOADED REACTOR CORE in pool. 	<p>Site Area Emergency</p> <p>HS4 HOSTILE ACTION within the PROTECTED AREA</p> <p>Operating Mode Applicability: All</p> <p>Threshold Value:</p> <ol style="list-style-type: none"> A HOSTILE ACTION is occurring or has occurred within the PROTECTED AREA as reported by the Security Shift Supervisor. This threshold does not apply to a hostile action to the (SFESI) Protected Area only. 	<p>Alert</p> <p>HA4 HOSTILE ACTION within the OWNER CONTROLLED AREA or Airborne Attack Threat</p> <p>Operating Mode Applicability: All</p> <p>Threshold Value:</p> <ol style="list-style-type: none"> A HOSTILE ACTION is occurring or has occurred within the OWNER CONTROLLED AREA as reported by the Security Shift Supervisor. <p>OR</p> <ol style="list-style-type: none"> A validated notification from NRC of an ARLINER attack threat within 30 minutes of the site. 	<p>Unusual Event</p> <p>HU4 Confirmed SECURITY CONDITION or Threat Which Indicates a Potential Degradation in the Level of Safety of the Plant.</p> <p>Operating Mode Applicability: All</p> <p>Threshold Value:</p> <ol style="list-style-type: none"> A SECURITY CONDITION that does NOT involve a HOSTILE ACTION as reported by the Security Shift Supervisor. <p>OR</p> <ol style="list-style-type: none"> A credible Turkey Point security threat notification. A validated notification from NRC providing information of an aircraft threat.
DEFINITION BOX			
<p>ARLINER – Airliner is meant to be a large aircraft with the potential for causing significant damage to the plant.</p> <p>FRESHLY OFF-LOADED REACTOR CORE IN POOL – A freshly off-loaded reactor core, in the Spent Fuel Pool, exists during the period of time when core off-load begins until core reload is complete.</p> <p>HOSTILE ACTION – An act toward a Nuclear Power Plant (NPP) or its personnel that includes the use of violent force to destroy equipment, take HOSTAGES, and/or intimidate the licensee to achieve an end. This includes attack by air, land, or water using guns, explosives, PROJECTILES, vehicles, or other devices used to deliver destructive force. Other acts that satisfy the overall intent may be included. HOSTILE ACTION should not be construed to include acts of civil disobedience or felonious acts that are not part of a concerted attack on the NPP. Non-terrorism-based EALs should be used to address such activities (i.e., this may include violent acts between individuals in the owner controlled area).</p> <p>IMMINENT – Mitigation actions have been ineffective, additional actions are not expected to be successful, and trended information indicates that the event or condition will occur. Where IMMINENT timeframes are specified, they shall apply.</p> <p>OWNER CONTROLLED AREA – That portion of FPL property surrounding and including the Turkey Point Nuclear Power Plant which is subject to limited access and control as deemed appropriate by FPL. (EPlan)</p> <p>PROTECTED AREA – The area (within the Owner Controlled Area) occupied by the nuclear units and associated equipment and facilities enclosed within the security perimeter fence. The area within which accountability of personnel is maintained in an emergency. This does not include the (SFESI) Protected Area.</p> <p>SECURITY CONDITION – Any Security Event as listed in the approved security contingency plan that constitutes a threat/compromise to site security, threat/risk to site personnel, or a potential degradation to the level of safety of the plant. A SECURITY CONDITION does not involve a HOSTILE ACTION.</p> <p>VISIBLE DAMAGE – Damage to equipment or structure that is readily observable without measurements, testing, or analysis. Damage is sufficient to cause concern regarding the continued operability or reliability of the affected structure, system, or component. Example damage includes: deformation due to heat or impact, denting, penetration, rupture, cracking, and paint blistering. Surface blemishes (e.g., paint chipping, scratches) should not be included.</p> <p>VITAL AREAS – Areas within the PROTECTED AREA, that contains equipment, systems, components, or material, the failure, destruction, or release of which could directly or indirectly endanger the public health and safety by exposure to radiation.</p>			

Rec. Cat.	General Emergency	Site Area Emergency	Alert	Unusual Event
H - HAZARDS AND OTHER CONDITIONS AFFECTING PLANT SAFETY	HG2 - Basis: This EAL addresses unanticipated conditions not addressed explicitly elsewhere but that warrant declaration of an emergency because conditions exist which are believed by the Emergency Coordinator to fall under the emergency classification level for General Emergency.	HS3 - Basis: This EAL addresses unanticipated conditions not addressed explicitly elsewhere but that warrant declaration of an emergency because conditions exist which are believed by the Emergency Coordinator to fall under the emergency classification level description for Site Area Emergency.	HA6 - Basis: This EAL addresses unanticipated conditions not addressed explicitly elsewhere but that warrant declaration of an emergency because conditions exist which are believed by the Emergency Coordinator to fall under the Alert emergency classification level.	HU5 - Basis: This EAL addresses unanticipated conditions not addressed explicitly elsewhere but that warrant declaration of an emergency because conditions exist which are believed by the Emergency Coordinator to fall under the Notification of Unusual Event (NOUE) emergency class.

Recognition Category	H – HAZARDS AND OTHER CONDITIONS AFFECTING PLANT SAFETY
	<p align="center">DISCRETIONARY</p>
<p align="center">Unusual Event</p>	<p>HU5 Other Conditions Existing Which in the Judgment of the Emergency Coordinator Warrant Declaration of a Notification of Unusual Event (NOUE).</p> <p>Operating Mode Applicability: All</p> <p>Threshold Value:</p> <p>1. Other conditions exist which in the judgment of the Emergency Coordinator indicate that events are in progress or have occurred which indicate a potential for a security event that could result in substantial degradation of the level of safety of the plant or a security event that involves probable life threatening risk to site personnel or equipment because of HOSTILE ACTION. Any releases are expected to be limited to small fractions of the EPA Protective Action Guideline exposure levels.</p>
<p align="center">Alert</p>	<p>HA6 Other Conditions Existing Which in the Judgment of the Emergency Coordinator Warrant Declaration of an Alert.</p> <p>Operating Mode Applicability: All</p> <p>Threshold Value:</p> <p>1. Other conditions exist which in the judgment of the Emergency Coordinator indicate that events are in progress or have occurred which indicate a potential for a security event that could result in substantial degradation of the level of safety of the plant or a security event that involves probable life threatening risk to site personnel or equipment because of HOSTILE ACTION. Any releases are expected to be limited to small fractions of the EPA Protective Action Guideline exposure levels.</p>
<p align="center">Site Area Emergency</p>	<p>HS3 Other Conditions Existing Which in the Judgment of the Emergency Coordinator Warrant Declaration of Site Area Emergency.</p> <p>Operating Mode Applicability: All</p> <p>Threshold Value:</p> <p>1. Other conditions exist which in the judgment of the Emergency Coordinator indicate that events are in progress or have occurred which indicate a potential for a security event that could result in substantial degradation of the level of safety of the plant or a security event that involves probable life threatening risk to site personnel or equipment because of HOSTILE ACTION. Any releases are expected to be limited to small fractions of the EPA Protective Action Guideline exposure levels beyond the site boundary.</p>
<p>HG2 Other Conditions Existing Which in the Judgment of the Emergency Coordinator Warrant Declaration of General Emergency.</p> <p>Operating Mode Applicability: All</p> <p>Threshold Value:</p> <p>1. Other conditions exist which in the judgment of the Emergency Coordinator indicate that events are in progress or have occurred which involve actual or IMMINENT substantial core degradation or melting with potential for loss of containment integrity or HOSTILE ACTION that results in an actual loss of physical control of the facility. Releases can be reasonably expected to exceed EPA Protective Action Guideline exposure levels off-site for more than the immediate site area.</p>	<p align="center">DEFINITION BOX</p> <p>HOSTILE ACTION – An act toward a Nuclear Power Plant (NPP) or its personnel that includes the use of violent force to destroy equipment, take HOSTAGES, and/or intimidate the licensee to achieve an end. This includes attack by air, land, or water using guns, explosives, PROJECTILES, vehicles, or other devices used to deliver destructive force. Other acts that satisfy the overall intent may be included. HOSTILE ACTION should not be construed to include acts of civil disobedience or felonious acts that are not part of a concerted attack on the NPP. Non-terrorism-based EALS should be used to address such activities (i.e., this may include violent acts between individuals in the owner controlled area).</p> <p>IMMINENT – Mitigation actions have been ineffective, additional actions are not expected to be successful, and trended information indicates that the event or condition will occur. Where IMMINENT timeframes are specified, they shall apply.</p> <p>PROJECTILE – An object directed toward a Nuclear Power Plant (NPP) that could cause concern for its continued operability, reliability, or personnel safety.</p>

This Page Intentionally Left Blank



**RECOGNITION CATEGORY E
EVENTS RELATED TO ISFSI**

Rec. Cat.	Site Area Emergency	Alert	Unusual Event
E - EVENTS RELATED TO ISFSI		<p>DEFINITION BOX</p> <p>CONFINEMENT BOUNDARY – The barrier(s) between areas containing radioactive substances and the environment.</p> <p>EXPLOSION – A rapid, violent, unconfined combustion, or catastrophic failure of pressurized energized equipment that imparts energy of sufficient force to potentially damage permanent structures, systems, or components.</p> <p>FIRE – Combustion characterized by heat and light. Sources of smoke such as slipping drive belts or overheated electrical equipment do not constitute FIRES. Observation of flame is preferred but is NOT required if large quantities of smoke and heat are observed.</p> <p>PROJECTILE – An object directed toward a Nuclear Power Plant (NPP) that could cause concern for its continued operability, reliability, or personnel safety.</p>	<p>E-HU1 – Basis:</p> <p>A Notification of Unusual Event (NOUE) in this IC is categorized on the basis of the occurrence of an event of sufficient magnitude that a loaded cask CONFINEMENT BOUNDARY is damaged or violated. This includes classification based on a loaded fuel storage cask CONFINEMENT BOUNDARY loss leading to the degradation of the fuel during storage or posing an operational safety problem with respect to its removal from storage as indicated by elevated radiation readings from the loaded fuel storage cask.</p> <p>The results of the ISFSI Safety Analysis Report (SAR) per NUREG 1636 or SAR referenced in the cask's Certificate of Compliance and the related NRC Safety Evaluation Report identify natural phenomena events and accident conditions that could potentially affect the CONFINEMENT BOUNDARY. This EAL addresses a dropped cask, a tipped over cask, EXPLOSION, PROJECTILE damage, FIRE damage or natural phenomena affecting a cask (e.g., seismic event, tornado, etc.).</p>

<p style="text-align: center;">Site Area Emergency</p>	<p style="text-align: center;">Alert</p>	<p style="text-align: center;">Unusual Event</p>	<p style="text-align: center;">Reconition Category</p>
<p style="text-align: center;">CONFINEMENT BOUNDARY – The barrier(s) between areas containing radioactive substances and the environment.</p>		<p>E-HU1 Damage to a loaded cask CONFINEMENT BOUNDARY. Operating Mode Applicability: Not applicable Threshold Value: 1. Damage to a loaded cask CONFINEMENT BOUNDARY.</p>	<p style="text-align: center;">E – EVENTS RELATED TO ISFSI</p>
<p style="text-align: center;">DEFINITION BOX</p>		<p style="text-align: center;">ISFSI</p>	

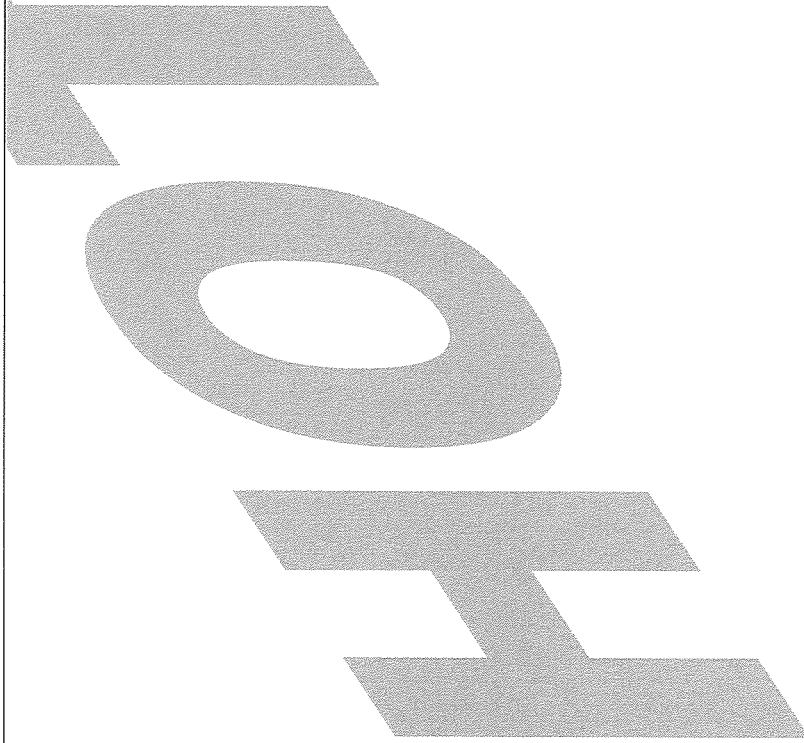



This Page Intentionally Left Blank

COLD CONDITIONS TABLE INDEX

PAGE
2

EMERGENCY ACTION LEVELS MATRIX.....

RECOGNITION CATEGORIES

R – Abnormal Rad Levels / Radiological Effluent.....	4-8
Radiological Effluent.....	6
Abnormal Rad Levels.....	8
C – Cold Shutdown / Refueling System Malfunction.....	10-16
AC Power.....	12
Communications.....	16
Criticality.....	14
DC Power.....	14
Decay Heat.....	14
RCS Leakage / Inventory.....	12
H – Hazards and Other Conditions Affecting Plant Safety.....	18-26
Control Room Evacuation.....	24
Discretionary.....	26
Fire / Explosion.....	22
Natural or Man-Made Events.....	20
Security.....	24
Toxic / Flammable Gas.....	22
E – Events Related to ISFSI (Independent Spent Fuel Storage Installation).....	28-30

COLD CONDITIONS TABLE
(RCS ≤ 200°F)

This Page Intentionally Left Blank

R - ABNORMAL RAD LEVELS/RADIOLOGICAL EFFLUENT		RADILOGICAL EFFLUENT		RCS INVENTORY / RCS LEAKAGE / AC POWER		DC POWER		CRITICALITY		COMM.								
R - ABNORMAL RAD LEVELS/RADIOLOGICAL EFFLUENT	RG1	Off-site Dose Resulting from an Actual IMMINENT Release (C) with Core Radioactivity Greater Than 1000 mrem TEDE or 5000 mrem Thyroid ODE for the Actual or Projected Duration of the Release, Using Actual Meteorology.	Pg. 6	RA1	Any Release of Gaseous or Liquid Radionuclides to the Environment Greater Than 200 Times the ODCM for 15 Minutes or Longer.	Pg. 6	RU1	Any Release of Gaseous or Liquid Radionuclides to the Environment Greater Than 2 Times the ODCM for 60 Minutes or Longer.	Pg. 6	Alert	HA1	Natural or Destructive Phenomena Affecting the PROTECTED AREA.	Pgs. 20	Unusual Event	HU1	Natural or Destructive Phenomena Affecting the PROTECTED AREA.	Pgs. 20	
				RA2	Damage to Irradiated Fuel or Loss of Water Level that Has Resulted or Will Result in the Uncovering of Irradiated Fuel Outside the Reactor Vessel.	Pg. 8	RU2	UNPLANNED Rise in Plant Radiation Levels.	Pg. 8	HA2	FIRE or EXPLOSION Affecting the Core or Fuel Elements of the Reactor Required to Establish or Maintain Safe Shutdown.	Pg. 22	HA3	Access to a VITAL AREA is Prohibited due to Release of Toxic, Corrosive, Asphyxiant or Flammable Gases Which Jeopardize Operation of Systems Required to Maintain Safe Operations of the Reactor.	Pg. 22	HU2	FIRE Within the PROTECTED AREA or Uncontrolled Release of Radioactive Material or EXPLOSION within the PROTECTED AREA.	Pg. 22
				RA3	Rise in Radiation Levels Within the Facility that Impedes Operation of System Safety Functions.	Pg. 8				HA4	HOSTILE ACTION within the OWNER CONTROLLED AREA or Airborne Attack Threat.	Pg. 24	HA5	Control Room Evacuation has been Initiated.	Pg. 24	HU3	Release of Toxic, Corrosive, Asphyxiant or Flammable Gases Deleterious to NORMAL PLANT OPERATIONS.	Pg. 24
				CA1	Loss of RCS Inventory.	Pg. 12	CU1	RCS Leakage.	Pg. 12	HA6	Other Conditions Existing Which in the Judgment of the Emergency Coordinator Warrant Declaration of an Alert.	Pg. 26	HA7	Control Room Evacuation Has Been Initiated and Plant Control Cannot be Established.	Pg. 24	HU4	Confirmed SECURITY CONDITION or Threat Which Indicates a Potential Degradation in the Level of Safety of the Plant.	Pg. 24
				CA3	Loss of all Off-site and all On-site AC power to emergency busses for 15 minutes or longer.	Pg. 12	CU2	UNPLANNED loss of RCS inventory.	Pg. 12	HA8	Other Conditions Existing Which in the Judgment of the Emergency Coordinator Warrant Declaration of a General Emergency.	Pg. 26	HA9	Control Room Evacuation Has Been Initiated and Plant Control Cannot be Established.	Pg. 24	HU5	Other Conditions Existing Which in the Judgment of the Emergency Coordinator Warrant Declaration of a Notification of Unusual Event.	Pg. 26
				CA4	Inability to Maintain Plant in Cold Shutdown.	Pg. 14	CU3	AC power capability to emergency busses reduced to a single power source for 15 minutes or longer such that any additional single failure would result in unit tripout.	Pg. 12	HA10	Other Conditions Existing Which in the Judgment of the Emergency Coordinator Warrant Declaration of an Emergency.	Pg. 26	HA11	Control Room Evacuation Has Been Initiated and Plant Control Cannot be Established.	Pg. 24	HU6	Damage to a located cask confinement BOUNDARY.	Pg. 30
							CU4	UNPLANNED Loss of Decay Heat Removal Capability with Irradiated Fuel in the Reactor Vessel.	Pg. 14	HA12	Complete actions listed in EPIP-20101 Section 5.6	HA13	Complete actions listed in EPIP-20101 Section 5.7	HA14	Complete actions listed in EPIP-20101 Section 5.8	HA15	Complete actions listed in EPIP-20101 Section 5.5	
							CU5	Loss of Required DC Power for 15 Minutes Or Longer.	Pg. 14	HA16	Complete actions listed in EPIP-20101 Section 5.6	HA17	Complete actions listed in EPIP-20101 Section 5.7	HA18	Complete actions listed in EPIP-20101 Section 5.8	HA19	Complete actions listed in EPIP-20101 Section 5.5	
							CU6	Inadvertent Criticality.	Pg. 14	HA20	Complete actions listed in EPIP-20101 Section 5.6	HA21	Complete actions listed in EPIP-20101 Section 5.7	HA22	Complete actions listed in EPIP-20101 Section 5.8	HA23	Complete actions listed in EPIP-20101 Section 5.5	
										HA24	Complete actions listed in EPIP-20101 Section 5.6	HA25	Complete actions listed in EPIP-20101 Section 5.7	HA26	Complete actions listed in EPIP-20101 Section 5.8	HA27	Complete actions listed in EPIP-20101 Section 5.5	
										HA28	Complete actions listed in EPIP-20101 Section 5.6	HA29	Complete actions listed in EPIP-20101 Section 5.7	HA30	Complete actions listed in EPIP-20101 Section 5.8	HA31	Complete actions listed in EPIP-20101 Section 5.5	
										HA32	Complete actions listed in EPIP-20101 Section 5.6	HA33	Complete actions listed in EPIP-20101 Section 5.7	HA34	Complete actions listed in EPIP-20101 Section 5.8	HA35	Complete actions listed in EPIP-20101 Section 5.5	
										HA36	Complete actions listed in EPIP-20101 Section 5.6	HA37	Complete actions listed in EPIP-20101 Section 5.7	HA38	Complete actions listed in EPIP-20101 Section 5.8	HA39	Complete actions listed in EPIP-20101 Section 5.5	
										HA40	Complete actions listed in EPIP-20101 Section 5.6	HA41	Complete actions listed in EPIP-20101 Section 5.7	HA42	Complete actions listed in EPIP-20101 Section 5.8	HA43	Complete actions listed in EPIP-20101 Section 5.5	
										HA44	Complete actions listed in EPIP-20101 Section 5.6	HA45	Complete actions listed in EPIP-20101 Section 5.7	HA46	Complete actions listed in EPIP-20101 Section 5.8	HA47	Complete actions listed in EPIP-20101 Section 5.5	
										HA48	Complete actions listed in EPIP-20101 Section 5.6	HA49	Complete actions listed in EPIP-20101 Section 5.7	HA50	Complete actions listed in EPIP-20101 Section 5.8	HA51	Complete actions listed in EPIP-20101 Section 5.5	
										HA52	Complete actions listed in EPIP-20101 Section 5.6	HA53	Complete actions listed in EPIP-20101 Section 5.7	HA54	Complete actions listed in EPIP-20101 Section 5.8	HA55	Complete actions listed in EPIP-20101 Section 5.5	
										HA56	Complete actions listed in EPIP-20101 Section 5.6	HA57	Complete actions listed in EPIP-20101 Section 5.7	HA58	Complete actions listed in EPIP-20101 Section 5.8	HA59	Complete actions listed in EPIP-20101 Section 5.5	
										HA60	Complete actions listed in EPIP-20101 Section 5.6	HA61	Complete actions listed in EPIP-20101 Section 5.7	HA62	Complete actions listed in EPIP-20101 Section 5.8	HA63	Complete actions listed in EPIP-20101 Section 5.5	
										HA64	Complete actions listed in EPIP-20101 Section 5.6	HA65	Complete actions listed in EPIP-20101 Section 5.7	HA66	Complete actions listed in EPIP-20101 Section 5.8	HA67	Complete actions listed in EPIP-20101 Section 5.5	
										HA68	Complete actions listed in EPIP-20101 Section 5.6	HA69	Complete actions listed in EPIP-20101 Section 5.7	HA70	Complete actions listed in EPIP-20101 Section 5.8	HA71	Complete actions listed in EPIP-20101 Section 5.5	
										HA72	Complete actions listed in EPIP-20101 Section 5.6	HA73	Complete actions listed in EPIP-20101 Section 5.7	HA74	Complete actions listed in EPIP-20101 Section 5.8	HA75	Complete actions listed in EPIP-20101 Section 5.5	
										HA76	Complete actions listed in EPIP-20101 Section 5.6	HA77	Complete actions listed in EPIP-20101 Section 5.7	HA78	Complete actions listed in EPIP-20101 Section 5.8	HA79	Complete actions listed in EPIP-20101 Section 5.5	
										HA80	Complete actions listed in EPIP-20101 Section 5.6	HA81	Complete actions listed in EPIP-20101 Section 5.7	HA82	Complete actions listed in EPIP-20101 Section 5.8	HA83	Complete actions listed in EPIP-20101 Section 5.5	
										HA84	Complete actions listed in EPIP-20101 Section 5.6	HA85	Complete actions listed in EPIP-20101 Section 5.7	HA86	Complete actions listed in EPIP-20101 Section 5.8	HA87	Complete actions listed in EPIP-20101 Section 5.5	
										HA88	Complete actions listed in EPIP-20101 Section 5.6	HA89	Complete actions listed in EPIP-20101 Section 5.7	HA90	Complete actions listed in EPIP-20101 Section 5.8	HA91	Complete actions listed in EPIP-20101 Section 5.5	
										HA92	Complete actions listed in EPIP-20101 Section 5.6	HA93	Complete actions listed in EPIP-20101 Section 5.7	HA94	Complete actions listed in EPIP-20101 Section 5.8	HA95	Complete actions listed in EPIP-20101 Section 5.5	
										HA96	Complete actions listed in EPIP-20101 Section 5.6	HA97	Complete actions listed in EPIP-20101 Section 5.7	HA98	Complete actions listed in EPIP-20101 Section 5.8	HA99	Complete actions listed in EPIP-20101 Section 5.5	
										HA100	Complete actions listed in EPIP-20101 Section 5.6	HA101	Complete actions listed in EPIP-20101 Section 5.7	HA102	Complete actions listed in EPIP-20101 Section 5.8	HA103	Complete actions listed in EPIP-20101 Section 5.5	

This Page Intentionally Left Blank

RECOGNITION CATEGORY R

ABNORMAL RAD LEVELS / RADIOLOGICAL EFFLUENT

Rec. Cat.	Site Area Emergency	Alert	Unusual Event
<p>R01 – Basis:</p> <p>This IC addresses radioactivity releases that result in doses at or beyond the site boundary that exceed the EPA Protective Action Guides (PAGs). Public protective actions will be necessary. Releases of this magnitude are associated with the failure of plant systems needed for the protection of the public and likely involve fuel damage.</p> <p><u>Threshold Values</u></p> <p>The monitor list includes effluent monitors on all potential release pathways.</p> <p>Since dose assessment is based on actual meteorology, whereas the monitor reading Threshold is not, the results from these assessments may indicate that the classification is warranted. For this reason, emergency higher classification is warranted. For this reason, emergency assessments using actual meteorology and release information. If the results of these dose assessments are available when the classification is made (e.g., initiated at a lower classification level), the dose assessment results override the monitor reading EAL.</p>	<p>RS1 – Basis:</p> <p>This IC addresses radioactivity releases that result in doses at or beyond the site boundary that exceed 10% of the EPA Protective Action Guides (PAGs). Releases of this magnitude are associated with the failure of plant systems needed for the protection of the public.</p> <p><u>Threshold Values</u></p> <p>The monitor list in Threshold #1 includes effluent monitors on all potential release pathways.</p> <p>Since dose assessment is based on actual meteorology, whereas the monitor reading Threshold is not, the results from these assessments may indicate that the classification is warranted. For this reason, emergency higher classification is warranted. For this reason, emergency assessments using actual meteorology and release information. If the results of these dose assessments are available when the classification is made (e.g., initiated at a lower classification level), the dose assessment results override the monitor reading EAL.</p>	<p>RA1 – Basis:</p> <p>The Emergency Coordinator should not wait until the applicable time has elapsed, but should declare the event as soon as it is determined that the condition will likely exceed the applicable time.</p> <p>This IC addresses an actual or substantial potential decrease in the level of safety of the plant as indicated by a radiological release that exceeds regulatory commitments for an extended period of time.</p> <p>Nuclear power plants incorporate features intended to control the release of radioactive effluents to the environment. Further, there are administrative controls established to prevent unintentional releases, or control and monitor intentional releases. These controls are located in the Off-site Dose Calculation Manual (ODCM). The occurrence of extended, uncontrolled radioactive releases to the environment is indicative of a degradation in these features and/or controls.</p> <p>The ODCM multiples are specified in RU1 and RA1 only to distinguish between non-emergency conditions, and from each other. While these multiples obviously correspond to an off-site dose or dose rate, the emphasis in classifying these events is the degradation in the level of safety of the plant, not the magnitude of the associated dose or dose rate.</p> <p>This Threshold includes any release for which a radioactivity discharge permit was not prepared, or a release that exceeds the conditions (e.g., minimum dilution flow, maximum discharge flow, alarm setpoints, etc.) on the applicable permit.</p> <p>Threshold #1</p> <p>This Threshold is intended for effluent monitoring on non-routine release pathways for which a discharge permit would not normally be prepared. The threshold values of this EAL are to be 200 times the ODCM limit or 100 times the threshold values used in RU1. This is true except for the thresholds given for the liquid release pathways (PRMS-R-18 and PRMS-314-R-19). On both PRMS, the calculated values exceeded the range of the monitors. Therefore, the values used in the EAL are 95% of full scale. This lesser threshold is still indicative of a loss of control of radioactive material well in excess of that constituting an Unusual Event.</p> <p>Threshold #2</p> <p>This Threshold addresses radioactivity releases, that for whatever reason, cause effluent radiation monitor readings to exceed the threshold identified in the IC established by the radioactivity discharge permit. This value may be associated with a planned batch release, or a continuous release path.</p> <p>Threshold #3</p> <p>This Threshold addresses uncontrolled releases that are detected by sample analyses, particularly on unmonitored pathways, e.g., spills of radioactive liquids into storm drains, heat exchanger leakage in river water systems, etc.</p> <p>The underlying basis of this Threshold involves the degradation in the level of safety of the plant implied by the uncontrolled release.</p>	<p>RU1 – Basis:</p> <p>The Emergency Coordinator should not wait until the applicable time has elapsed, but should declare the event as soon as it is determined that the condition will likely exceed the applicable time.</p> <p>This IC addresses a potential decrease in the level of safety of the plant as indicated by a radiological release that exceeds regulatory commitments for an extended period of time.</p> <p>Nuclear power plants incorporate features intended to control the release of radioactive effluents to the environment. Further, there are administrative controls established to prevent unintentional releases, or control and monitor intentional releases. These controls are located in the Off-site Dose Calculation Manual (ODCM). The occurrence of extended, uncontrolled radioactive releases to the environment is indicative of a degradation in these features and/or controls.</p> <p>The ODCM multiples are specified in RU1 and RA1 only to distinguish between non-emergency conditions, and from each other. While these multiples obviously correspond to an off-site dose or dose rate, the emphasis in classifying these events is the degradation in the level of safety of the plant, not the magnitude of the associated dose or dose rate.</p> <p>Releases should not be prorated or averaged. For example, a release exceeding 4x ODCM for 30 minutes does not meet the threshold.</p> <p>This Threshold includes any release for which a radioactivity discharge permit was not prepared, or a release that exceeds the conditions (e.g., minimum dilution flow, maximum discharge flow, alarm setpoints, etc.) on the applicable permit.</p> <p>Threshold #1</p> <p>This Threshold addresses radioactivity releases, that for whatever reason, cause effluent radiation monitor readings to exceed the threshold identified in the IC.</p> <p>This Threshold is intended for sites that have established effluent monitoring on non-routine release pathways for which a discharge permit would not normally be prepared.</p> <p>Threshold #2</p> <p>This Threshold addresses radioactivity releases, that for whatever reason, cause effluent radiation monitor readings to exceed the threshold identified in the IC established by the radioactivity discharge permit. This value may be associated with a planned batch release, or a continuous release path.</p> <p>Threshold #3</p> <p>This Threshold addresses uncontrolled releases that are detected by sample analyses, particularly on unmonitored pathways, e.g., spills of radioactive liquids into storm drains, heat exchanger leakage in river water systems, etc.</p> <p>The underlying basis of this Threshold involves the degradation in the level of safety of the plant implied by the uncontrolled release.</p>
<p>R – ABNORMAL RAD LEVELS/RADIOLOGICAL EFFLUENT</p>	<p>ATTACHMENT 2 - F-669 - REV 1 (EPIP-20101)</p>	<p>TURKEY POINT CLASSIFICATION TABLE</p>	<p>COLD CONDITIONS 5</p>

R – ABNORMAL RAD LEVELS/RADIOLOGICAL EFFLUENT

RADIOLOGICAL EFFLUENT

Recognition Category

Unusual Event

RU1 Any Release of Gaseous or Liquid Radioactivity to the Environment Greater Than 2 Times the ODCM for 60 Minutes or Longer.
Operating Mode Applicability: All
Threshold Values:
Note: The Emergency Coordinator should not wait until the applicable time has elapsed, but should declare the event as soon as it is determined that the release duration has exceeded, or will likely exceed, the applicable time. In the absence of data to the contrary, assume that the release duration has exceeded the applicable time if an ongoing release is detected and the release start time is unknown.
 1. VALID reading on ANY of the following radiation monitors greater than the value shown for 60 minutes or longer.

Monitor	Pathway	Value
RAD-6304	Plant Vent SPING	3.4E-4 uCi/cc
RAD 6418	Unit 4 Via Plant Vent SPING	1.4E-3 uCi/cc
RAD 6426 (DAM-1)	N/A	N/A
RAD-3(4)-6417	SJAE SPING	9.1E-1 uCi/cc
PRMS R-18	Liquid Rad Waste Effluent Line	1.8E+4 cpm
PRMS-3(4)-R-19	Any one Steam Generator Blowdown	1.8E+4 cpm
PRMS R-14	Plant Vent (PV)	6.8E+4 cpm

2. VALID reading on any effluent monitor reading greater than 2 times the alarm setpoint established by a current radioactivity discharge permit for 60 minutes or longer.
 3. Confirmed sample analyses for gaseous or liquid releases indicates concentrations or release rates greater than 2 times ODCM limits for 60 minutes or longer.

GUIDANCE BOX FOR USE OF SPING MONITORS IN RADIOLOGICAL EFFLUENT TABLES

The calculations for the SPING monitors listed are based on NOBLE GAS levels; use SPING channels 5, 7, and 9 as appropriate for the indicated values in the tables. (Ref: DBD PTFN-NEI-99-01)

Channel	Range	Typical Reading
Ch-5	1.0E-07 - 6.0E-02	5.0E-07
Ch-7	2.5E-02 - 4.0E+02	1.0E-04
Ch-9	1.0E+00 - 1.0E+05	1.0E-01

Alert

RA1 Any Release of Gaseous or Liquid Radioactivity to the Environment Greater Than 200 Times the Radiological Effluent Technical Specifications/ODCM for 15 Minutes or Longer.
Operating Mode Applicability: All
Threshold Values:
Note: The Emergency Coordinator should not wait until the applicable time has elapsed, but should declare the event as soon as it is determined that the release duration has exceeded, or will likely exceed, the applicable time. In the absence of data to the contrary, assume that the release duration has exceeded the applicable time if an ongoing release is detected and the release start time is unknown.
 1. VALID reading on ANY of the following radiation monitors greater than the value shown for 15 minutes or longer.

Monitor	Pathway	Value
RAD-6304	Plant Vent SPING	3.4E-2 uCi/cc
RAD 6418	Unit 4 Via Plant Vent SPING	1.4E-1 uCi/cc
RAD 6426 (DAM-1)	Main Steam Line Monitor	2.9E+0 uCi/cc
RAD-3(4)-6417	SJAE SPING	9.1E+1 uCi/cc
PRMS R-18	Liquid Rad Waste Effluent Line	2.4E+5 cpm
PRMS-3(4)-R-19	Any one Steam Generator Blowdown	2.4E+5 cpm

2. VALID reading on any effluent monitor reading that greater than 200 times the alarm setpoint established by a current radioactivity discharge permit for 15 minutes or longer.
 3. Confirmed sample analyses for gaseous or liquid releases indicates concentrations or release rates greater than 200 times ODCM limits for 15 minutes or longer.

GUIDANCE BOX FOR USE OF SPING MONITORS IN RADIOLOGICAL EFFLUENT TABLES

The calculations for the SPING monitors listed are based on NOBLE GAS levels; use SPING channels 5, 7, and 9 as appropriate for the indicated values in the tables. (Ref: DBD PTFN-NEI-99-01)

Channel	Range	Typical Reading
Ch-5	1.0E-07 - 6.0E-02	5.0E-07
Ch-7	2.5E-02 - 4.0E+02	1.0E-04
Ch-9	1.0E+00 - 1.0E+05	1.0E-01

Site Area Emergency

RS1 Off-site Dose Resulting from an Actual or IMMINENT Release of Gaseous Radioactivity Greater Than 100 mrem TEDE or 500 mrem Thyroid CDE for the Actual or Projected Duration of the Release.
Operating Mode Applicability: All
Threshold Values:
Note: The Emergency Coordinator should not wait until the applicable time has elapsed, but should declare the event as soon as it is determined that the condition will likely exceed the applicable time. If dose assessment results are available, declaration should be based on dose assessment instead of radiation monitor values. Do not delay declaration awaiting dose assessment results.
 1. VALID reading on ANY of the following radiation monitors greater than the value shown for 15 minutes or longer.

Monitor	Pathway	Value
RAD-6304	Plant Vent SPING	3.0E-1 uCi/cc
RAD 6418	Unit 4 Via Plant Vent SPING	1.2E+0 uCi/cc
RAD 6426 (DAM-1)	Main Steam Line Monitor	2.8E+1 uCi/cc
RAD-3(4)-6417	SJAE SPING	8.0E+2 uCi/cc

2. Dose assessment using actual meteorology indicates doses greater than 100 mrem TEDE or 500 mrem thyroid CDE at or beyond the site boundary.
 3. Field survey results indicate closed window dose rates greater than 100 mR/hr expected to continue for 60 minutes or longer; or analyses of field survey samples indicate thyroid CDE greater than 5000 mrem for one hour of inhalation, at or beyond the site boundary.

GUIDANCE BOX FOR USE OF SPING MONITORS IN RADIOLOGICAL EFFLUENT TABLES

The calculations for the SPING monitors listed are based on NOBLE GAS levels; use SPING channels 5, 7, and 9 as appropriate for the indicated values in the tables. (Ref: DBD PTFN-NEI-99-01)

Channel	Range	Typical Reading
Ch-5	1.0E-07 - 6.0E-02	5.0E-07
Ch-7	2.5E-02 - 4.0E+02	1.0E-04
Ch-9	1.0E+00 - 1.0E+05	1.0E-01

Site Area Emergency

RG1 Off-site Dose Resulting from an Actual or IMMINENT Release of Gaseous Radioactivity Greater Than 1000 mrem TEDE or 5000 mrem Thyroid CDE for the Actual or Projected Duration of the Release Using Actual Meteorology.
Operating Mode Applicability: All
Threshold Values:
Note: The Emergency Coordinator should not wait until the applicable time has elapsed, but should declare the event as soon as it is determined that the condition will likely exceed the applicable time. If dose assessment results are available, declaration should be based on dose assessment instead of radiation monitor values. Do not delay declaration awaiting dose assessment results.
 1. VALID reading on ANY of the following radiation monitors greater than the value shown for 15 minutes or longer.

Monitor	Pathway	Value
RAD-6304	Plant Vent SPING	3.0E+0 uCi/cc
RAD 6418	Unit 4 Via Plant Vent SPING	1.2E+1 uCi/cc
RAD 6426 (DAM-1)	Main Steam Line Monitor	2.8E+2 uCi/cc
RAD-3(4)-6417	SJAE SPING	8.0E+3 uCi/cc

2. Dose assessment using actual meteorology indicates doses greater than 1000 mrem TEDE or 5000 mrem thyroid CDE at or beyond the site boundary.
 3. Field survey results indicate closed window dose rates greater than 1000 mR/hr expected to continue for 60 minutes or longer; or analyses of field survey samples indicate thyroid CDE greater than 5000 mrem for one hour of inhalation, at or beyond site boundary.

GUIDANCE BOX FOR USE OF SPING MONITORS IN RADIOLOGICAL EFFLUENT TABLES

The calculations for the SPING monitors listed are based on NOBLE GAS levels; use SPING channels 5, 7, and 9 as appropriate for the indicated values in the tables. (Ref: DBD PTFN-NEI-99-01)

Channel	Range	Typical Reading
Ch-5	1.0E-07 - 6.0E-02	5.0E-07
Ch-7	2.5E-02 - 4.0E+02	1.0E-04
Ch-9	1.0E+00 - 1.0E+05	1.0E-01

DEFINITION BOX
IMMINENT – Mitigation actions have been ineffective, additional actions are not expected to be successful, and trended information indicates that the event or condition will occur. Where **IMMINENT** timeframes are specified, they shall apply.
VALID – An indication, report, or condition, is considered to be VALID when it is verified by (1) an instrument channel check, (2) indications on related or redundant indicators, or (3) by direct indication by personnel, each that doubt related to the indication is removed, the condition's occurrence, or the report's accuracy is removed. Implicit in this definition is the need for timely assessment.

Rec. Cat.	Site Area Emergency	Alert	Unusual Event
R - ABNORMAL RAD LEVELS/RADIOLOGICAL EFFLUENT		<p>RA2 - Basis:</p> <p>This IC addresses increases in radiation dose rates within plant buildings, and may be a precursor to a radioactivity release to the environment. These events represent a loss of control over radioactive material and represent an actual or substantial potential degradation in the level of safety of the plant.</p> <p>Threshold #1 A specific value is not specified in that the elevation of any fuel bundles in transit must be considered for evaluating this condition.</p> <p>Threshold #2 This Threshold addresses radiation monitor indications of fuel uncover and/or fuel damage.</p> <p>Increased ventilation monitor readings may be indication of a radioactivity release from the fuel, confirming that damage has occurred. Increased background at the ventilation monitor due to water level decrease may mask increased ventilation exhaust airborne activity and needs to be considered.</p> <p>While a radiation monitor could detect an increase in dose rate due to a drop in the water level, it might not be a reliable indication of whether or not the fuel is covered.</p> <p>Escalation of this emergency classification level, if appropriate, would be based on RST or RGT.</p> <p>RA3 - Basis:</p> <p>This IC addresses increased radiation levels that impact continued operation in areas requiring continuous occupancy to maintain safe operation or to perform a safe shutdown.</p> <p>The cause and/or magnitude of the increase in radiation levels is not a concern of this IC. The Emergency Coordinator must consider the source or cause of the increased radiation levels and determine if any other IC may be involved.</p> <p>Areas requiring continuous occupancy are the Control Room and CAS</p> <p>The value of 15mR/hr is derived from the GDC 19 value of 5 rem in 30 days with adjustment for expected occupancy times. Although Section III.D.3 of NUREG-0737, "Clarification of TMI Action Plan Requirements", provides that the 15 mR/hr value can be averaged over the 30 days, the value is used here without averaging, as a 30 day duration implies an event potentially more significant than an Alert.</p>	<p>RU2 - Basis:</p> <p>This IC addresses increased radiation levels as a result of water level decreases above irradiated fuel or events that have resulted, or may result, in UNPLANNED increases in radiation dose rates within plant buildings. These radiation increases represent a loss of control over radioactive material and represent a potential degradation in the level of safety of the plant.</p> <p>Threshold #1 The refueling pathway is the combination of the refueling cavity, transfer canal and spent fuel pool. While a radiation monitor could detect an increase in dose rate due to a drop in the water level, it might not be a reliable indication of whether or not the fuel is covered.</p> <p>For refueling events where the water level drops below the RPV flange classification level per the CU2, this event escalates to an Alert per RA2, if irradiated fuel is uncovered. For refueling events involving irradiated fuel in the reactor vessel, escalation would be via the Fission Product Barrier Table for events in operating modes 1-4.</p> <p>Threshold #2 This Threshold addresses increases in plant radiation levels that represent a loss of control of radioactive material resulting in a potential degradation in the level of safety of the plant.</p> <p>This Threshold excludes radiation level increases that result from planned activities such as use of radiographic sources and movement of radioactive waste materials. A specific list of ARMs is not required as it would restrict the applicability of the Threshold. The intent is to identify loss of control of radioactive material in any monitored area.</p> <p>This event escalates to an Alert per RA3 if the increase in dose rates impedes personnel access necessary for safe operation.</p>
<p>GUIDANCE BOX FOR USE OF TEMPORARY MONITORS IN ABNORMAL RADIATION TABLES</p> <p>Portable radiation monitors staged as compensatory actions for OOS monitors should be used in place of installed equipment for the purpose of this EAL.</p>			

Site Area Emergency

Alert

Unusual Event

Recognition Category

R - ABNORMAL RAD LEVELS/RADIOLOGICAL EFFLUENT

ABNORMAL RAD LEVELS

RA2 Damage to Irradiated Fuel or Loss of Water Level that Has Resulted or Will Result in the Uncovering of Irradiated Fuel Outside the Reactor Vessel.

Operating Mode Applicability: All

Threshold Values:

1. A water level drop in the reactor refueling cavity, spent fuel pool or fuel transfer canal that will result in irradiated fuel becoming uncovered.
- OR
2. A VALID elevated reading of greater than or equal to 1.0 E+4 mR/hr on ANY of the following due to damage to irradiated fuel or loss of water level.

Unit 3	Unit 4
RI-3-1402B UNIT 3 CONTAINMENT OPERATING FLOOR	RI-4-1405B, UNIT 4 CONTAINMENT OPERATING FLOOR
RI-3-1407B, UNIT 3 SPENT FUEL PIT CANAL AREA	RI-4-1408B, UNIT 4 SPENT FUEL PIT CANAL AREA
RI-3-1421B UNIT 3 SPENT FUEL PIT NORTH WALL	RI-4-1422B UNIT 4 SPENT FUEL PIT SOUTH WALL

RU2 UNPLANNED Rise in Plant Radiation Levels.

Operating Mode Applicability: All

Threshold Values:

- 1.a. UNPLANNED water level drop in a reactor refueling pathway as indicated by LT-3(41-651 56" 10" (SFP LO LEVEL Alarm).
- AND
- b. VALID Area Radiation Monitor reading rise on any of the following:

Unit 3	Unit 4
RI-3-1402B, UNIT 3 CONTAINMENT OPERATING FLOOR	RI-4-1405B, UNIT 4 CONTAINMENT OPERATING FLOOR
RI-3-1407B, UNIT 3 SPENT FUEL PIT CANAL AREA	RI-4-1408B, UNIT 4 SPENT FUEL PIT CANAL AREA
RI-3-1421B UNIT 3 SPENT FUEL PIT NORTH WALL	RI-4-1422B UNIT 4 SPENT FUEL PIT SOUTH WALL

OR

2. UNPLANNED VALID Area Radiation Monitor readings or survey results indicate a rise by a factor of 1000 over normal* levels.

*Normal can be considered as the highest reading in the past twenty-four hours excluding the current peak value.

GUIDANCE BOX FOR RUIZ, Threshold 1

This event addresses increased radiation levels as a result of decreasing water level above irradiated fuel. Spent Fuel Pool low level alarms resulting from routine evaporation accompanied by normal and expected area radiation levels are not subject to this EAL.

RA3 Rise in Radiation Levels Within the Facility That Impedes Operation of Systems Required to Maintain Safe Plant Safety Functions.

Operating Mode Applicability: All

Threshold Values:

1. Dose rate greater than 15 mR/hr in ANY of the following areas requiring continuous occupancy to maintain plant safety functions:
 - Control Room
 - CAS

GUIDANCE BOX FOR USE OF MONITORS IN ABNORMAL RADIATION TABLES

Area Radiation monitors in the Control Room indicate in mR/hr up to 100 mR/hr. Monitors automatically switch to Rem/hr as noted at the monitor.

GUIDANCE BOX FOR USE OF TEMPORARY MONITORS IN ABNORMAL RADIATION TABLES

Portable radiation monitors staged as compensatory actions for OOS monitors may be used in place of installed equipment, only if data is available to the control room, for the purpose of this EAL.

DEFINITION BOX

UNPLANNED - A parameter change or an event that is not the result of an intended evolution and requires corrective or mitigative actions.

VALID - An indication, report, or condition, is considered to be VALID when it is verified by (1) an instrument channel check, (2) indications on related or redundant indicators, or (3) by direct observation by plant personnel, such that doubt related to the indicator's operability, the condition's existence, or the report's accuracy is removed. Implicit in this definition is the need for timely assessment.

This Page Intentionally Left Blank

RECOGNITION CATEGORY C
COLD SHUTDOWN / REFUELING
SYSTEM MALFUNCTIONS

Recognition Category		C – COLD SHUTDOWN / REFUELING SYSTEM MALFUNCTIONS					
Unusual Event		Alert					
CG1 Loss of RCS Inventory Affecting Fuel Clad Integrity with Containment Challenged. Operating Mode Applicability: 5, 6 Threshold Value: Note: <i>The Emergency Coordinator should not wait until the applicable time has elapsed, but should declare the event as soon as it is determined that the condition will likely exceed the applicable time.</i> 1. RCS level less than 10% on EITHER LIS-3(4)-6421 or LIS-3(4)-6423 for 30 minutes or longer. AND 2. ANY containment challenge indication (see Table); OR a. RCS level cannot be monitored with core uncover indicated by ANY of the following for 30 minutes or longer: <ul style="list-style-type: none"> • RAD-3(4)-6311B reading greater than 1.2E+3 R/hr. • Erratic source range monitor indication. • Unexplained level rise in <ul style="list-style-type: none"> • Containment Sump • #1 Waste Holdup Tank • CVCS Holdup Tank • RWST AND b. ANY containment challenge indication: Containment Challenge Indications <ul style="list-style-type: none"> • CONTAINMENT CLOSURE not established. • 4% H₂ inside containment. • UNPLANNED rise in containment pressure. 	CS1 Loss of RCS Inventory Affecting Core Decay Heat Removal Capability. Operating Mode Applicability: 5, 6 Threshold Values: Note: <i>The Emergency Coordinator should not wait until the applicable time has elapsed, but should declare the event as soon as it is determined that the condition will likely exceed the applicable time.</i> 1. With CONTAINMENT CLOSURE not established, RCS level less than 15% on EITHER LIS-3(4)-6421 or LIS-3(4)-6423. OR 2. With CONTAINMENT CLOSURE established, RCS level less than 10% on EITHER LIS-3(4)-6421 or LIS-3(4)-6423. OR 3. RCS level cannot be monitored for 30 minutes or longer with a loss of RCS inventory as indicated by ANY of the following: <ul style="list-style-type: none"> • RAD-3(4)-6311B reading greater than 7.6E+1 R/hr. • Erratic Source Range Monitor Indication. • Unexplained level rise in <ul style="list-style-type: none"> • Containment Sump • #1 Waste Holdup Tank • CVCS Holdup Tank • RWST 	CA1 Loss of RCS Inventory. Operating Mode Applicability: 5, 6 Threshold Values: Note: <i>The Emergency Coordinator should not wait until the applicable time has elapsed, but should declare the event as soon as it is determined that the condition will likely exceed the applicable time.</i> 1. Loss of RCS inventory as indicated by RX VESSEL DRAIN/DOWN LO, LO LEVEL Alarm I 7/3 (24% on either LIS-3(4)-6421 or LIS-3(4)-6423) OR 2. RCS level cannot be monitored for 15 minutes or longer with a loss of RCS inventory as indicated by an unexplained level rise in ANY of the following: <ul style="list-style-type: none"> • Containment Sump • #1 Waste Holdup Tank • CVCS Holdup Tank • RWST 	CU2 UNPLANNED Loss of RCS Inventory. Operating Mode Applicability: 6 Threshold Values: Note: <i>The Emergency Coordinator should not wait until the applicable time has elapsed, but should declare the event as soon as it is determined that the condition will likely exceed the applicable time.</i> 1. UNPLANNED RCS level drop as indicated by either of the following: <ul style="list-style-type: none"> • RCS water level drop below the RPV flange for 15 minutes or longer when the RCS level band is established above the RPV flange. • RCS water level drop below the RCS level band for 15 minutes or longer when the RCS level band is established below the RPV flange. OR 2. RCS level cannot be monitored with a loss of RCS inventory as indicated by an unexplained level rise in: <ul style="list-style-type: none"> • Containment Sump • #1 Waste Holdup Tank • CVCS Holdup Tank • RWST CU1 RCS Leakage. Operating Mode Applicability: 5 Threshold Values: Note: <i>The Emergency Coordinator should not wait until the applicable time has elapsed, but should declare the event as soon as it is determined that the condition will likely exceed the applicable time.</i> 1. RCS leakage results in the inability to maintain or restore level within the pressurizer or RCS level target band for 15 minutes or longer.				
				CG2 Loss of RCS Inventory Affecting Core Decay Heat Removal Capability. Operating Mode Applicability: 5, 6 Threshold Values: Note: <i>The Emergency Coordinator should not wait until the applicable time has elapsed, but should declare the event as soon as it is determined that the condition will likely exceed the applicable time.</i> 1. With CONTAINMENT CLOSURE not established, RCS level less than 15% on EITHER LIS-3(4)-6421 or LIS-3(4)-6423. OR 2. With CONTAINMENT CLOSURE established, RCS level less than 10% on EITHER LIS-3(4)-6421 or LIS-3(4)-6423. OR 3. RCS level cannot be monitored for 30 minutes or longer with a loss of RCS inventory as indicated by ANY of the following: <ul style="list-style-type: none"> • RAD-3(4)-6311B reading greater than 7.6E+1 R/hr. • Erratic Source Range Monitor Indication. • Unexplained level rise in <ul style="list-style-type: none"> • Containment Sump • #1 Waste Holdup Tank • CVCS Holdup Tank • RWST 	CA2 Loss of RCS Inventory. Operating Mode Applicability: 5, 6 Threshold Values: Note: <i>The Emergency Coordinator should not wait until the applicable time has elapsed, but should declare the event as soon as it is determined that the condition will likely exceed the applicable time.</i> 1. Loss of RCS inventory as indicated by RX VESSEL DRAIN/DOWN LO, LO LEVEL Alarm I 7/3 (24% on either LIS-3(4)-6421 or LIS-3(4)-6423) OR 2. RCS level cannot be monitored for 15 minutes or longer with a loss of RCS inventory as indicated by an unexplained level rise in ANY of the following: <ul style="list-style-type: none"> • Containment Sump • #1 Waste Holdup Tank • CVCS Holdup Tank • RWST 	CU2 UNPLANNED Loss of RCS Inventory. Operating Mode Applicability: 6 Threshold Values: Note: <i>The Emergency Coordinator should not wait until the applicable time has elapsed, but should declare the event as soon as it is determined that the condition will likely exceed the applicable time.</i> 1. UNPLANNED RCS level drop as indicated by either of the following: <ul style="list-style-type: none"> • RCS water level drop below the RPV flange for 15 minutes or longer when the RCS level band is established above the RPV flange. • RCS water level drop below the RCS level band for 15 minutes or longer when the RCS level band is established below the RPV flange. OR 2. RCS level cannot be monitored with a loss of RCS inventory as indicated by an unexplained level rise in: <ul style="list-style-type: none"> • Containment Sump • #1 Waste Holdup Tank • CVCS Holdup Tank • RWST CU1 RCS Leakage. Operating Mode Applicability: 5 Threshold Values: Note: <i>The Emergency Coordinator should not wait until the applicable time has elapsed, but should declare the event as soon as it is determined that the condition will likely exceed the applicable time.</i> 1. RCS leakage results in the inability to maintain or restore level within the pressurizer or RCS level target band for 15 minutes or longer.	CU3 AC Power Capability To Emergency Buses Reduced to a Single Power Source for 15 Minutes or longer such that Any Additional Single Failure Would Result in Unit Blackout. Operating Mode Applicability: 5, 6 Threshold Value: Note: <i>The Emergency Coordinator should not wait until the applicable time has elapsed, but should declare the event as soon as it is determined that the condition will likely exceed the applicable time.</i> 1. a. AC power capability to 3(4)A 4KV and 3(4)B 4KV Buses reduced to a single power source for 15 minutes or longer. AND b. Any additional single power source failure will result in unit blackout.
GUIDANCE BOX FOR CUI Planned evolutions to test, manipulate, repair, perform maintenance or modifications to systems and equipment that result in an EAL value being met or exceeded are not subject to classification and activation requirements as long as the evolution proceeds as planned and is within the operational limitations imposed by the specific operating license. [Turkey Point Technical Basis, Section 3.9]	GUIDANCE BOX FOR CUI The difference between CUI1 and CUI2 deals with the RCS conditions that exist between cold shutdown and refueling modes. In the refueling mode the RCS is not intact and Reactor Pressure Vessel level and inventory are monitored by different means. In cold shutdown the RCS will normally be intact and standard RCS inventory and level monitoring means are available. [NEI 99-01, page 45 of 167]						
DEFINITION BOX CONTAINMENT CLOSURE – The procedurally defined actions taken to secure containment and its associated structures, systems, and components as a functional barrier to fission product release under existing plant conditions. UNPLANNED – A parameter change or an event that is not the result of an intended evolution and requires corrective or mitigative actions.							

Rec. Cat.

C - COLD SHUTDOWN / REFUELING SYSTEM MALFUNCTIONS

Site Area Emergency

Alert

Unusual Event

CA4 - Basis:

For Threshold 1, the RCS Reheat Duration Threshold table addresses complete loss of functions required for core cooling for greater than 60 minutes during refueling and cold shutdown modes when RCS integrity is established. RCS integrity should be considered to be in place when the RCS pressure boundary is in its normal condition for the cold shutdown mode of operation (e.g., no freeze seals or nozzle dams). The status of CONTAINMENT CLOSURE in this condition is immaterial given that the RCS is providing a high pressure barrier to fission product release to the environment. The 60 minute time frame should allow sufficient time to restore cooling without there being a substantial degradation in plant safety.

The RCS Reheat Duration Threshold table also addresses the complete loss of functions required for core cooling for greater than 20 minutes during refueling and cold shutdown modes when CONTAINMENT CLOSURE is established but RCS integrity is not established or RCS inventory is reduced. The allowed 20 minute time frame was included to allow operator action to restore the heat removal function, if possible.

Complete loss of functions required for core cooling during refueling and cold shutdown modes when neither CONTAINMENT CLOSURE nor RCS integrity are established. No delay time is allowed because the evaporated reactor coolant that may be released into the Containment during this heatup condition could also be directly released to the environment.

The note (*) indicates that this Threshold is not applicable if actions are successful in restoring an RCS heat removal system to operation and RCS temperature is being reduced within the specified time frame.

In Threshold 2, the 10 psi pressure increase addresses situations where, due to high decay heat loads, the time provided to restore temperature control, should be less than 60 minutes.

Escalation to Site Area Emergency would be via CS1 should boiling result in significant RPV level loss leading to core uncover.

NRC analyses show that there are sequences that can cause core uncover in 15 to 20 minutes and severe core damage within an hour after decay heat removal is lost.

A loss of Technical Specification components alone is not intended to constitute an Alert. The same is true of a momentary UNPLANNED excursion above the Technical Specification cold shutdown temperature limit when the heat removal function is available.

The Emergency Coordinator must remain alert to events or conditions that lead to the conclusion that exceeding the Threshold is IMMINENT. If, in the judgment of the Emergency Coordinator, an IMMINENT situation is at hand, the classification should be made as if the Threshold has been exceeded.

CA4 - Basis:

This IC is a precursor of more serious conditions and, as a result, is considered to be a potential degradation of the level of safety of the plant. In cold shutdown, the ability to remove decay heat relies primarily on forced cooling flow. Operation of the systems that provide this forced cooling may be jeopardized due to the unlikely loss of electrical power or RCS inventory. Since the RCS usually remains intact in the cold shutdown mode a large inventory of water is available to keep the core covered.

During refueling, the level in the RPV will normally be maintained above the RPV flange. Refueling evolutions that decrease water level below the RPV flange are carefully planned and procedurally controlled. Loss of forced decay heat removal at reduced inventory may result in more rapid increases in RCS temperatures depending on the time since shutdown.

Normal means of core temperature indication and RCS level indication may not be available in the refueling mode. Redundant means of RPV level indication are therefore procedurally installed to assure that the ability to monitor level will not be interrupted. However, if all level and temperature indicator were to be lost in either the cold shutdown or refueling modes, Threshold 2 would result in declaration of a NOUE if both temperature and level indication cannot be restored within 15 minutes from the loss of both means of indication. Escalation to Alert would be via CA1 based on an inventory loss or CA4 based on exceeding its temperature criteria.

CU6 - Basis:

The purpose of this IC and its associated Threshold Values is to recognize a loss of communications capability that either defeats the plant operations staff ability to perform routine tasks necessary for plant operations or the ability to communicate issues with off-site authorities. The loss of off-site communications ability is expected to be significantly more comprehensive than the condition addressed by 10 CFR 50.72.

The availability of one method of ordinary off-site communications is sufficient to inform federal, state, and local authorities of plant issues. This Threshold is intended to be used only when extraordinary means (e.g. relaying of information from radio transmissions, individuals being sent to off-site locations, etc.) are being utilized to make communications possible.

The list for on-site and off-site communications loss encompasses the loss of all means of routine communications and all means of communications with off-site authorities.

CU7 - Basis:

The purpose of this IC and its associated Threshold Values is to recognize a loss of DC power compromising the ability to monitor and control the removal of decay heat during Cold Shutdown or Refueling operations.

It is intended that the loss of the operating (operable) train is to be considered. If this loss results in the inability to maintain cold shutdown, the escalation to an Alert will be per CA4.

Fifteen minutes was selected as a Threshold to exclude transient or momentary power losses.

CU8 - Basis:

This IC addresses critically events that occur in Cold Shutdown or Refueling modes such as fuel mis-loading events and inadvertent dilution events. This IC indicates a potential degradation of the level of safety of the plant, warranting a NOUE classification.

The term "sustained" is used in order to allow exclusion of expected short term startup rates from planned fuel bundle or control rod movements during core alteration. These short term positive startup rates are the result of the increase in neutron population due to subcritical multiplication. Escalation would be by Emergency Coordinator Judgment.

DEFINITION BOX
CONTAINMENT CLOSURE - The procedurally defined actions taken to secure containment and its associated structures, systems, and components as a functional barrier to fission product release under existing plant conditions.
IMMINENT - Mitigation actions have been ineffective, additional actions are not expected to be successful, and trended information indicates that the event or condition will occur. Where IMMINENT timeframes are specified, they shall apply.

Site Area Emergency

DEFINITION BOX
 UNPLANNED – A parameter change or an event that is not the result of an intended evolution and requires corrective or mitigative actions.

Alert

CA4 Inability to Maintain Plant in Cold Shutdown.
 Operating Mode Applicability: 5, 6
 Threshold Values:
 Note: The Emergency Coordinator should not wait until the applicable time has elapsed, but should declare the event as soon as it is determined that the condition will likely exceed the applicable time.
 1. An UNPLANNED event results in RCS temperature greater than 200 F for greater than the specified duration on table.

Table: RCS Reheat Duration Thresholds

RCS	Containment Closure	Duration
Intact (Vent Path NOT Established) (but not Reduced Inventory)	N/A	60 minutes*
Not Intact (Vent Path Established) or Reduced Inventory	Established	20 minutes*
	Not Established	0 minutes

* If an RCS heat removal system is in operation within this time frame and RCS temperature is being reduced, the EAL is not applicable.

OR
 2. An UNPLANNED event results in RCS pressure increase greater than 10 psi due to a loss of Shutdown Cooling. (This Threshold does not apply in Solid Plant conditions.)

Recognition Category

C – COLD SHUTDOWN / REFUELING SYSTEM MALFUNCTIONS

Unusual Event

CU4 UNPLANNED Loss of Decay Heat Removal Capability with Irradiated Fuel in the Reactor Vessel
 Operating Mode Applicability: 5, 6
 Threshold Values:
 Note: The Emergency Coordinator should not wait until the applicable time has elapsed, but should declare the event as soon as it is determined that the condition will likely exceed the applicable time.
 1. UNPLANNED event results in RCS temperature exceeding 200 F.
 OR
 2. Loss of all RCS temperature and RCS level indication for 15 minutes or longer.

CU7 Loss of Required DC Power for 15 Minutes Or Longer.
 Operating Mode Applicability: 5, 6
 Threshold Values:
 Note
 The Emergency Coordinator should not wait until the applicable time has elapsed, but should declare the event as soon as it is determined that the condition will likely exceed the applicable time.
 1. Less than 105 VDC on ANY 2 of the following required Vial DC buses for 15 minutes or longer:
 • 3D01
 • 3D03
 • 4D01
 • 4D23

CU8 Inadvertent Criticality.
 Operating Mode Applicability: 5, 6
 Threshold Values:
 1. UNPLANNED sustained positive startup rate observed on nuclear instrumentation.

Rec. Cat.	Site Area Emergency	Alert	Unusual Event
C - COLD SHUTDOWN / REFUELING SYSTEM MALFUNCTIONS			<p>CU6 - Basis:</p> <p>The purpose of this IC and its associated Threshold Values is to recognize a loss of communications capability that either defeats the plant operators staff ability to perform routine tasks necessary for plant operations or the ability to communicate issues with off-site authorities. The loss of off-site communications ability is expected to be significantly more comprehensive than the condition addressed by 10 CFR 50.72.</p> <p>The availability of one method of ordinary off-site communications is sufficient to inform federal, state, and local authorities of plant issues. This Threshold is intended to be used only when extraordinary means (e.g., relaying of information from radio transmissions, individuals being sent to off-site locations, etc.) are being utilized to make communications possible.</p> <p>The list for on-site and off-site communications loss encompasses the loss of all means of routine communications and all means of communications with off-site authorities.</p>

Recognition Category	C – COLD SHUTDOWN / REFUELING SYSTEM MALFUNCTIONS	
Unusual Event	<p>CU6 Loss of All On-site or Off-site Communications Capabilities.</p> <p>Operating Mode Applicability: 5, 6, Defueled</p> <p>Threshold Values:</p> <ol style="list-style-type: none"> Loss of all of the following on-site communication methods affecting the ability to perform routine operations. <ul style="list-style-type: none"> Plant Page Portable Radios Commercial Telephones (PBX) <p>OR</p> <ol style="list-style-type: none"> Loss of all of the following off-site communication methods affecting the ability to perform either of the following offsite notifications. <ul style="list-style-type: none"> Commercial Telephones * Federal Telecommunications System (FTS) 	Alert
Site Area Emergency	<p>GUIDANCE FOR CU6</p> <p>The following communications systems are available for off-site notifications from the control room:</p> <ol style="list-style-type: none"> State and County Notifications: <ul style="list-style-type: none"> Commercial Telephones * Hot Ring Down (HRD) Emergency Satellite Communications NRC Notification <ul style="list-style-type: none"> Emergency Notification System (ENS) Commercial Telephones <ul style="list-style-type: none"> Commercial phones include plant phones, direct outside lines and installed cell phones in the Control Room, but not personal cell phones 	Alert

This Page Intentionally Left Blank

RECOGNITION CATEGORY H

HAZARDS AND OTHER CONDITIONS

AFFECTING PLANT SAFETY

Rec. Cat.

H - HAZARDS AND OTHER CONDITIONS AFFECTING PLANT SAFETY

Site Area Emergency

DEFINITION BOX

EXPLOSION - A rapid, violent, unconfined combustion, or catastrophic failure of pressurized/energized equipment that imparts energy of sufficient force to potentially damage permanent structures, systems, or components.

FIRE - Combustion characterized by heat and light. Sources of smoke such as slipping drive belts or overheated electrical equipment do not constitute FIRES. Observation of flames is preferred but is NOT required if large quantities of smoke and heat are observed.

NORMAL PLANT OPERATIONS - Activities at the plant site associated with routine testing, maintenance, or equipment operations, in accordance with normal operating or administrative procedures. Entry into abnormal or emergency posture, or a departure from normal security or radiological controls posture, is a departure from NORMAL PLANT OPERATIONS.

PROJECTILE - An object directed toward a Nuclear Power Plant (NPP) that could cause concern for its continued operability, reliability, or personnel safety.

PROTECTED AREA - The area (within the Owner Controlled Area) occupied by the nuclear units and associated equipment and facilities enclosed within the security perimeter fence. The area within which accountability of personnel is maintained in an emergency. This does not include the ISFSI Protected Area.

VISIBLE DAMAGE - Damage to equipment or structure that is readily observable without measurements, testing, or analysis. Damage is sufficient to cause concern regarding the continued operability or reliability of the affected structure, system, or component. Example damage includes: deformation due to heat or impact, denting, penetration, rupture, cracking, and paint blistering. Surface blemishes (e.g., paint chipping, scratches) should not be included.

VITAL AREAS - Areas within the PROTECTED AREA that contains equipment, systems, components, or material, the failure, destruction, or release of which could directly or indirectly endanger the public health and safety by exposure to radiation.

Alert

HA1 - Basis:

These Thresholds escalate from HU1 in that the occurrence of the event has resulted in VISIBLE DAMAGE to plant structures or areas containing equipment necessary for a safe shutdown, or has caused damage to the safety systems in those structures evidenced by Control Room indications of degraded system response or performance.

The occurrence of VISIBLE DAMAGE and/or degraded system response is intended to discriminate against lesser events. The initial report should not be interpreted as mandating a lengthy damage assessment prior to classification. No attempt is made in this Threshold to assess the actual magnitude of the damage. The significance here is not that a particular system or structure was damaged, but rather, that the event was of sufficient magnitude to cause this degradation.

Escalation of this emergency classification level, if appropriate, would be based on System Malfunction CS.

Threshold #1

Seismic events of this magnitude can result in a VITAL AREA being subjected to forces beyond design limits, and thus damage may be assumed to have occurred to plant safety systems. The Modified Mercalli Intensity V (0.04 - 0.09 g) is indicated by:

- Felt by nearly everyone
- Light damage, some windows broken or unstable objects overturned.

The ETNA Seismograph Event Recorder Red LED Indicator ON indicates an event has been recorded. The red LED indicator flashing indicates an event is being recorded or the device is writing to memory. I&C should be contacted immediately.

The USGS National Earthquake Information Center can confirm if an earthquake has occurred in the area of the plant.

Threshold #2

This Threshold is based on a tornado striking (touching down) or high winds that have caused VISIBLE DAMAGE to structures containing functions or systems required for safe shutdown of the plant.

Threshold #3

This Threshold addresses the effect of internal flooding caused by events such as component failures, equipment misalignment, or outage activity mishaps. It is based on the degraded performance of systems, or that has created industrial safety hazards (e.g., electrical shock) that preclude necessary access to operate or monitor safety equipment. The inability to access, operate or monitor safety equipment represents an actual or substantial potential degradation of the level of safety of the plant.

Flooding as used in this Threshold describes a condition where water is entering the room faster than installed equipment is capable of removal, resulting in a rise of water level within the room. Classification of this Threshold should not be delayed while corrective actions are being taken to isolate the water source.

Threshold #5

This Threshold addresses vehicle crashes within the PROTECTED AREA that results in VISIBLE DAMAGE to VITAL AREAS or indication of damage to safety structures, systems, or components containing functions and systems required for safe shutdown of the plant.

Threshold #6

This Threshold addresses other natural phenomena that result in VISIBLE DAMAGE to VITAL AREAS or results in indication of damage to safety structures, systems, or components containing functions and systems required for safe shutdown of the plant in the event of a hurricane and the associated storm surge that can also be precursors of more serious events.

Unusual Event

HU1 - Basis:

These Thresholds are categorized on the basis of the occurrence of an event of sufficient magnitude to be of concern to plant operators.

Threshold #1

Damage may be caused to some portions of the site, but should not affect ability of safety functions to operate. The Modified Mercalli Intensity IV (0.01 - 0.04 g) is indicated by:

- Felt indoors by many, outdoors by few
- No damage

As defined in the EPRI-sponsored Guidelines for Nuclear Plant Response to an Earthquake, dated October 1985, a "felt earthquake" is: An earthquake of sufficient intensity such that: (a) the vibratory ground motion is felt at the nuclear plant site and recognized as an earthquake based on a consensus of Control Room operators on duty at the time, and (b) for plants with operable seismic instrumentation, the seismic switches of the plant are activated.

The ETNA Seismograph Event Recorder Red LED Indicator ON indicates an event has been recorded. The red LED indicator flashing indicates an event is being recorded or the device is writing to memory. I&C should be contacted immediately.

The USGS National Earthquake Information Center can confirm if an earthquake has occurred in the area of the plant.

Threshold #2

This Threshold is based on a tornado striking (touching down) or high winds within the PROTECTED AREA.

The high wind Threshold Value (100 mph) is based on approaching the FSAR design basis maximum wind speed value (WS mph) and is within the calibrated range of control room instrument wind escalation of this emergency classification level, if appropriate, would be based on VISIBLE DAMAGE via HA1.

Threshold #3

This Threshold addresses the effect of internal flooding caused by events such as component failures, equipment misalignment, or outage activity mishaps.

Escalation of this emergency classification level, if appropriate, would be based on VISIBLE DAMAGE via HA1, or by other plant conditions.

Threshold #4

This Threshold addresses main turbine rotating component failures of sufficient magnitude to cause observable damage to the turbine casing or to the seals of the turbine generator. Generator seal damage observed after generator purge does not meet the intent of this Threshold because it did not impact normal operation of the plant.

Of major concern is the potential for leakage of combustible fluids (lubricating oils) and gases (hydrogen cooling) to the plant environs. Actual FIRES and flammable gas build up are appropriately classified via HU2 and HU3.

This Threshold is consistent with the definition of a NOUE while maintaining the anticipatory nature desired and recognizing the risk to non-safety related equipment.

Escalation of this emergency classification level, if appropriate, would be to HA1 based on damage done by PROJECTILES generated by the failure.

Threshold #5

This Threshold addresses natural phenomena for a hurricane and the associated storm surge that can also be precursors of more serious events.

H – HAZARDS AND OTHER CONDITIONS AFFECTING PLANT SAFETY

NATURAL OR MAN-MADE EVENTS

HA1 Natural or Destructive Phenomena Affecting VITAL AREAS.

Operating Mode Applicability: All

Threshold Values:

1. a. Earthquake confirmed by ANY of the following:
 - Earthquake felt in plant
 - Modified Mercalli Intensity V evaluated
 - USGS National Earthquake Information Center

AND

- b. Control Room indication of degraded performance of systems required for the safe shutdown of the plant.

OR

- c. Seismic event greater than Operating Basis Earthquake (OBE) as indicated by the ETNA Seismograph Event Recorder indicating greater than or equal to 0.05g.

OR

2. Tornado striking OR high winds greater than 100 mph resulting in VISIBLE DAMAGE to ANY of the Table H1 plant structures containing safety systems or components OR Control Room indication of degraded performance of those safety systems.

OR

3. Internal flooding in the RHR Pump Rooms resulting in an electrical shock hazard that precludes access to operate or monitor safety equipment OR Control Room indication of degraded performance of those safety systems.

OR

4. Turbine failure resulting in VISIBLE DAMAGE to or degradation of ANY of the Table H1 plant structures containing safety systems or components OR control room indication of degraded performance of those safety systems.

OR

5. Vehicle crash resulting in VISIBLE DAMAGE to ANY of the Table H1 plant structures containing safety systems or components OR Control Room indication of degraded performance of those safety systems.

OR

6. Natural occurrences resulting in VISIBLE DAMAGE to ANY of the Table H1 plant structures containing safety systems or components OR Control Room indication of degraded performance of those safety systems.

HA1 Natural or Destructive Phenomena Affecting VITAL AREAS.

Operating Mode Applicability: All

Threshold Values:

1. Seismic event confirmed by ANY 2 of the following:
 - Seismic event confirmed by the ETNA Seismograph Event Recorder Red LED Indicator ON.
 - Earthquake felt in plant
 - Modified Mercalli Intensity IV evaluated
 - USGS National Earthquake Information Center

OR

2. Tornado striking within PROTECTED AREA boundary or high winds greater than 100 mph.

OR

3. Internal flooding in the RHR Pump Rooms that has the potential to affect safety related equipment required by Technical Specifications for the current operating mode:

OR

4. Turbine failure resulting in casing penetration or damage to turbine or generator seals.

OR

5. Natural occurrences affecting the PROTECTED AREA.
 - Confirmed hurricane warning is in effect.
 - Flood surge that prevents land access to the site

HA1 Natural or Destructive Phenomena Affecting VITAL AREAS.

Operating Mode Applicability: All

Threshold Values:

1. a. Earthquake confirmed by ANY of the following:
 - Earthquake felt in plant
 - Modified Mercalli Intensity V evaluated
 - USGS National Earthquake Information Center

AND

- b. Control Room indication of degraded performance of systems required for the safe shutdown of the plant.

OR

- c. Seismic event greater than Operating Basis Earthquake (OBE) as indicated by the ETNA Seismograph Event Recorder indicating greater than or equal to 0.05g.

OR

2. Tornado striking OR high winds greater than 100 mph resulting in VISIBLE DAMAGE to ANY of the Table H1 plant structures containing safety systems or components OR Control Room indication of degraded performance of those safety systems.

OR

3. Internal flooding in the RHR Pump Rooms resulting in an electrical shock hazard that precludes access to operate or monitor safety equipment OR Control Room indication of degraded performance of those safety systems.

OR

4. Turbine failure resulting in VISIBLE DAMAGE to or degradation of ANY of the Table H1 plant structures containing safety systems or components OR control room indication of degraded performance of those safety systems.

OR

5. Vehicle crash resulting in VISIBLE DAMAGE to ANY of the Table H1 plant structures containing safety systems or components OR Control Room indication of degraded performance of those safety systems.

OR

6. Natural occurrences resulting in VISIBLE DAMAGE to ANY of the Table H1 plant structures containing safety systems or components OR Control Room indication of degraded performance of those safety systems.

TABLE H1

Turbine Building	Feedwater Platforms
Control Building/Roof	Condensate Storage Tanks
EDG Buildings	UR DOST
Containment Buildings	Spent Fuel Areas
Auxiliary Building/Roof	Component Cooling Water Area
3/4 C Bus/XFMRs and 1/2 E LC	HHSI Pump Area
DWST	Fuel Handling Building
Main/Aux/Startup XFMRs	Refueling Water Storage Tanks
UA Laidown Area	Primary Water Storage Tanks
Main Steam Platforms	Intake

DEFINITION BOX

EXPLOSION – A rapid, violent, unconfined combustion, or catastrophic failure of pressurized/energized equipment that imparts energy of sufficient force to potentially damage permanent structures, systems, or components.

FIRE – Combustion characterized by heat and light. Sources of smoke such as slipping drive belts or overheated electrical equipment do not constitute FIRES. Observation of flames is preferred but is NOT required if large quantities of smoke and heat are observed.

NORMAL PLANT OPERATIONS – Activities at the plant site associated with routine testing, maintenance, or equipment operations, in accordance with normal operating or administrative procedures. Entry into abnormal or emergency operating procedures, or deviation from normal security or radiological controls posture, is a departure from NORMAL PLANT OPERATIONS.

PROJECTILE – An object directed toward a Nuclear Power Plant (NPP) that could cause concern for its continued operability, reliability, or personnel safety.

PROTECTED AREA – The area (within the Owner Controlled Area) occupied by the nuclear units and associated equipment and facilities enclosed within the security perimeter fence. The area within which accountability of personnel is maintained in an emergency. This does not include the ISFSI Protected Area.

VISIBLE DAMAGE – Damage to equipment or structure that is readily observable without measurements, testing, or analysis. Damage is sufficient to cause concern regarding the continued operability or reliability of the affected structure, system, or component. Example damage includes: deformation due to heat or impact, denting, penetration, rupture, cracking, and paint blistering. Surface blemishes (e.g., paint chipping, scratches) should not be included.

VITAL AREAS – Areas within the PROTECTED AREA that contains equipment, systems, components, or material, the failure, destruction, or release of which could directly or indirectly endanger the public health and safety by exposure to radiation.

Site Area Emergency	Alert	Unusual Event
<p>DEFINITION BOX</p> <p>VITAL AREAS – Areas within the PROTECTED AREA, that contains equipment, systems, components, or material, the failure, destruction, or release of which could directly or indirectly endanger the public health and safety by exposure to radiation.</p> <p>EXPLOSION – A rapid, violent, unconfined combustion, or catastrophic failure of pressurized/energized equipment that imparts energy of sufficient force to potentially damage permanent structures, systems, or components.</p> <p>FIRE – Combustion characterized by heat and light. Sources of smoke such as slipping drive belts or overheated electrical equipment do not constitute FIRES. Observation of flame is preferred but is NOT required if large quantities of smoke and heat are observed.</p> <p>NORMAL PLANT OPERATIONS – Activities at the plant site associated with routine testing, maintenance, or equipment operations, in accordance with normal operating or administrative procedures. Entry into abnormal or emergency operating procedures, or deviation from normal security or radiological controls posture, is a departure from NORMAL PLANT OPERATIONS.</p> <p>PROJECTILE – An object directed toward a Nuclear Power Plant (NPP) that could cause concern for its continued operability, reliability, or personnel safety.</p> <p>PROTECTED AREA – The area (within the Owner Controlled Area) occupied by the nuclear units and associated equipment and facilities enclosed within the security perimeter fence. The area within which accountability of personnel is maintained in an emergency. This does not include the (SPS) Protected Area.</p> <p>VISIBLE DAMAGE – Damage to equipment or structure that is readily observable without measurements, testing, or analysis. Damage is sufficient to cause concern regarding the continued operability or reliability of the affected structure, system, or component. Example damage includes: deformation due to heat or impact, denting, penetration, rupture, cracking, and paint blistering. Surface blemishes (e.g., paint chipping, scratches) should not be included.</p>	<p>HA2 – Basis:</p> <p>VISIBLE DAMAGE is used to identify the magnitude of the FIRE or EXPLOSION and to discriminate against minor FIRES and EXPLOSIONS. The reference to structures containing safety systems, or components is included to discriminate against FIRES or EXPLOSIONS in areas having a low probability of affecting safe operation. The significance here is not that a safety system was degraded but the fact that the FIRE or EXPLOSION was large enough to cause damage to these systems.</p> <p>The use of VISIBLE DAMAGE should not be interpreted as mandating a lengthy damage assessment prior to classification. The declaration of an Alert and the activation of the Technical Support Center will provide the Emergency Coordinator with the resources needed to perform detailed damage assessments.</p> <p>The Emergency Coordinator also needs to consider any security aspects of the EXPLOSION.</p> <p>Escalation of this emergency classification level, if appropriate, will be based on System Malfunctions, Fission Product Barrier Degradation or Abnormal Rad Levels / Radiological Effluent ICs.</p> <p>HA3 – Basis:</p> <p>Gases in a VITAL AREA can affect the ability to safely operate or safety shutdown the reactor.</p> <p>The fact that SCBA may be worn does not eliminate the need to declare the event.</p> <p>Declaration should not be delayed for confirmation from atmospheric testing if the atmosphere poses an immediate threat to life and health or an immediate threat of severe exposure to gases. This could be based upon documented analysis, indication of personal ill effects from exposure, or operating experience with the hazards.</p> <p>If the equipment in the stated area was already inoperable, or out of service, before the event occurred, then this EAL should not be declared as it will have no adverse impact on the ability of the plant to safely operate or safely shutdown beyond that already allowed by Technical Specifications at the time of the event.</p> <p>An asphyxiant is a gas capable of reducing the level of oxygen in the body to dangerous levels. Most commonly, asphyxiants work by merely displacing air in an enclosed environment. This reduces the concentration of oxygen from the normal level of around 19%, which can lead to breathing difficulties, unconsciousness or even death.</p> <p>An uncontrolled release of flammable gasses within a facility structure has the potential to affect safe operation of the plant by limiting either operator or equipment operations due to the potential for ignition and resulting equipment damage/personnel injury. Flammable gasses, such as hydrogen and acetylene, are routinely used to maintain plant systems (hydrogen) or to repair equipment/components (acetylene - used in welding). This Threshold assumes concentrations of flammable gasses which can ignite/support combustion.</p> <p>Escalation of this emergency classification level, if appropriate, will be based on System Malfunctions, Fission Product Barrier Degradation or Abnormal Rad Levels / Radiological Effluent ICs.</p>	<p>HA2 – Basis:</p> <p>This Threshold addresses the magnitude and extent of FIRES or EXPLOSIONS that may be precursors of damage to safety systems. It addresses the FIRE/EXPLOSION, and not the degradation in performance of affected systems that may result.</p> <p>As used here, detection is visual observation and report by plant personnel or sensor alarm indication.</p> <p>Threshold #1</p> <p>The 15 minute time period begins with a credible notification that a FIRE is occurring, or indication of a fire detection system alarm/actuation. Verification of a fire detection system alarm/actuation includes actions that can be taken within the Control Room or other nearby location to ensure that it is not spurious. An alarm is not to be considered a FIRE unless it is disproved within the 15 minute period by personnel dispatched to the area. If a credible alarm report from the same may be used to disprove a sensor alarm if received within 15 minutes of the alarm, but shall not be required to verify the alarm.</p> <p>The intent of this 15 minute duration is to size the FIRE and to discriminate against small FIRES that are readily extinguished (e.g., smoldering waste paper basket).</p> <p>Threshold #2</p> <p>This Threshold addresses only those EXPLOSIONS of sufficient force to damage permanent structures or equipment within the PROTECTED AREA. No attempt is made to assess the actual magnitude of the damage. The occurrence of the EXPLOSION is sufficient for declaration.</p> <p>The Emergency Coordinator also needs to consider any security aspects of the EXPLOSION, if applicable.</p> <p>Escalation of this emergency classification level, if appropriate, would be based on HA2.</p> <p>HA3 – Basis:</p> <p>This Threshold is based on the release of toxic, corrosive, asphyxiant or flammable gases of sufficient quantity to affect NORMAL PLANT OPERATIONS.</p> <p>The fact that SCBA may be worn does not eliminate the need to declare the event.</p> <p>This IC is not intended to require significant assessment or quantification. It assumes an uncontrolled process that has the potential to affect plant operations. This would preclude small or incidental releases, or releases that do not impact structures needed for plant operation.</p> <p>An asphyxiant is a gas capable of reducing the level of oxygen in the body to dangerous levels. Most commonly, asphyxiants work by merely displacing air in an enclosed environment. This reduces the concentration of oxygen below the normal level of around 19%, which can lead to breathing difficulties, unconsciousness or even death.</p> <p>Escalation of this emergency classification level, if appropriate, would be based on HA3.</p>

Site Area Emergency

Alert

Unusual Event

Recognition Category

DEFINITION BOX

VITAL AREAS – Areas within the PROTECTED AREA, that contains equipment, systems, components, or material, the failure, destruction, or release of which could directly or indirectly endanger the public health and safety by exposure to radiation.

EXPLOSION – A rapid, violent, unconfined combustion, or catastrophic failure of pressurized/energized equipment that imparts energy of sufficient force to potentially damage permanent structures, systems, or components.

FIRE – Combustion characterized by heat and light. Sources of smoke such as slipping drive belts or overheated electrical equipment do not constitute FIRES. Observation of flame is preferred but is NOT required if large quantities of smoke and heat are observed.

NORMAL PLANT OPERATIONS – Activities at the plant site associated with routine testing, maintenance, or equipment operations, in accordance with normal operating or administrative procedures. Entry into abnormal or emergency operating procedures, or deviation from normal security or radiological controls posture, is a departure from NORMAL PLANT OPERATIONS.

PROJECTILE – An object directed toward a Nuclear Power Plant (NPP) that could cause concern for its continued operability, reliability, or personnel safety.

PROTECTED AREA – The area (within the Owner Controlled Area) occupied by the nuclear units and associated equipment and facilities enclosed within the security perimeter fence. The area within which accountability of personnel is maintained in an emergency. This does not include the ISFSI Protected Area.

VISIBLE DAMAGE – Damage to equipment or structure that is readily observable without measurements, testing, or analysis. Damage is sufficient to cause concern regarding the continued operability or reliability of the affected structure, system, or component. Example damage includes: deformation due to heat or impact; denting, penetration, rupture, cracking, and paint blistering. Surface blemishes (e.g., paint chipping, scratches) should not be included.

HA2 FIRE or EXPLOSION Affecting the Operability of Plant Safety Systems Required to Establish or Maintain Safe Shutdown.

Operating Mode Applicability: All

Threshold Value:

- FIRE or EXPLOSION resulting in VISIBLE DAMAGE to ANY of the following structures containing safety systems or components OR Control Room indication or degraded performance of those safety systems.

Turbine Building
Control Building/Roof
EDG Buildings
Containment Buildings
Auxiliary Building/Roof
3/4 C Bus/XFMRs and 3/4 E LC
DWST
Main/Aux/Startup XFMRs
U4 Laydown Area
Main Steam Platforms
Intake

HU2 FIRE Within the PROTECTED AREA Not Extinguished Within 15 Minutes of Detection OR EXPLOSION within the PROTECTED AREA.

Operating Mode Applicability: All

Threshold Value:

Note: The Emergency Coordinator should not wait until the applicable time has elapsed, but should declare the event as soon as it is determined that the duration has exceeded, or will likely exceed, the applicable time.

FIRE in any of the following areas not extinguished within 15 minutes of a FIRE Alarm or Control Room notification.

Turbine Building
Control Building/Roof
EDG Buildings
Containment Buildings
Auxiliary Building/Roof
3/4 C Bus/XFMRs and 3/4 E LC
DWST
Main/Aux/Startup XFMRs
U4 Laydown Area
Main Steam Platforms
Intake

H – HAZARDS AND OTHER CONDITIONS AFFECTING PLANT SAFETY

FIRE / EXPLOSION

TOXIC / FLAMMABLE GAS

HA3 Access to a VITAL AREA is Prohibited Due To Toxic, Corrosive, Asphyxiant or Flammable Gases Which Jeopardize Operation of Operable Equipment Required to Maintain Safe Operations or Safety Shutdown the Reactor.

Operating Mode Applicability: All

Threshold Values:

Note: If the equipment in the stated area was already inoperable, or out of service, before the event occurred, then this EAL should not be declared as it will have no adverse impact on the ability of the plant to safely operate or safely shutdown beyond that already allowed by Technical Specifications at the time of the event.

- Access to a VITAL AREA is prohibited due to toxic, corrosive, asphyxiant or flammable gases which jeopardize operation of systems required to maintain safe operations or safety shutdown the reactor.

HU3 Release of Toxic, Corrosive, Asphyxiant, or Flammable Gases Deleterious to NORMAL PLANT OPERATIONS.

Operating Mode Applicability: All

Threshold Values:

- Toxic, corrosive, asphyxiant or flammable gases in amounts that have or could adversely affect NORMAL PLANT OPERATIONS.
- Report by local, county or state officials for evacuation or sheltering of site personnel based on an off-site event.

GUIDANCE BOX FOR HU3, HA3

Planned controlled activities, such as Containment entry at power, do not meet the intent of HU3 or HA3.

Rec. Cat.	Site Area Emergency	Alert	Unusual Event
<p>HG1 – Basis:</p> <p>Threshold #1</p> <p>This Threshold encompasses conditions under which a HOSTILE ACTION has resulted in a loss of physical control of VITAL AREAS (containing vital equipment or controls of vital equipment) required to maintain safety functions and control of that equipment cannot be transferred to and operated from another location.</p> <p>These safety functions are reactivity control, RCS inventory, and secondary heat removal.</p> <p>If control of the plant equipment necessary to maintain safety functions can be transferred to another location, then the threshold is not met.</p> <p>Threshold #2</p> <p>This Threshold addresses failure of spent fuel cooling systems as a result of HOSTILE ACTION if IMMINENT fuel damage is likely, such as when a freshly off-loaded reactor core is in the spent fuel pool.</p> <p>DEFINITION BOX</p> <p>AIRLINER – Airliner is meant to be a large aircraft with the potential for causing significant damage to the plant.</p> <p>FRESHLY OFF-LOADED REACTOR CORE - A freshly off-loaded Reactor core in the Spent Fuel Pool exists during the period of time when core off-load begins until core reload is complete.</p> <p>HOSTILE ACTION – An act toward a NPP or its personnel that includes the use of violent force to destroy equipment, take HOSTAGES, and/or intimidate the licensee to achieve an end. This includes attack by air, land, or water using guns, explosives, PROJECTILES, vehicles, or other devices used to deliver destructive force. Other acts that satisfy the overall intent may be included. HOSTILE ACTION should not be construed to include acts of civil disobedience or felonious acts that are not part of a concerted attack on the NPP. Non-terrorism-based EALS should be used to address such activities (i.e., this may include violent acts between individuals in the owner controlled area).</p> <p>IMMINENT – Mitigation actions have been ineffective, additional actions are not expected to be successful, and trended information indicates that the event or condition will occur. Where IMMINENT timeframes are specified, they shall apply.</p> <p>OWNER CONTROLLED AREA – That portion of FFL property surrounding and including the Turkey Point Nuclear Power Plant which is subject to limited access and control as deemed appropriate by FFL.</p> <p>PROTECTED AREA – The area (within the Owner Controlled Area) occupied by the nuclear units and associated equipment and facilities enclosed within the security perimeter fences. The area within which accountability of personnel is maintained in an emergency. This does not include the ISFSI Protected Area.</p> <p>SECURITY CONDITION – Any Security Event as listed in the approved security contingency plan that constitutes a threat/compromise to the security, threat/risk to site personnel, or a potential degradation to the level of safety of the plant. A SECURITY CONDITION does not involve a HOSTILE ACTION.</p> <p>VISIBLE DAMAGE – Damage to equipment or structure that is readily observable without measurements, testing, or analysis. Damage is sufficient to cause concern regarding the continued operability or reliability of the affected structure, system, or component. Example damage includes: deformation due to heat or impact, denting, penetration, rupture, cracking, and paint blistering. Surface blemishes (e.g., paint chipping, scratches) should not be included.</p>	<p>HS4 – Basis:</p> <p>This condition represents an escalated threat to plant safety above that contained in the Alert in that a HOSTILE FORCE has progressed from the OWNER CONTROLLED AREA to the PROTECTED AREA.</p> <p>This Threshold addresses the contingency for a very rapid progression of events, such as that experienced on September 11, 2001. It is not premised solely on the potential for a radiological release. Rather, the issue includes the need for rapid assistance due to the possibility for significant and indeterminate damage from additional air, land or water attack elements.</p> <p>The fact that the site is under serious attack with minimal time available for further preparation or additional assistance to arrive requires ORO readiness and preparation for the implementation of protective measures.</p> <p>This Threshold addresses the potential for a very rapid progression of events due to a HOSTILE ACTION. It is not intended to address incidents that are accidental events or acts of civil disobedience, such as small aircraft impact, hunters, or physical disputes between employees within the PROTECTED AREA. Those events are adequately addressed by other Thresholds.</p> <p>This initiating condition and EAL do not apply to an attack solely in the ISFSI Protected Area. An attack on the ISFSI Protected Area should be considered an attack within the Owner Controlled Area and classified as an Alert per Initiating Condition HA4.</p> <p>Escalation of this emergency classification level, if appropriate, would be based on actual plant status after impact or progression of attack.</p>	<p>HA4 – Basis:</p> <p>Note: Timely and accurate communication between Security Shift Supervision and the Control Room is crucial for the implementation of effective Security EALS.</p> <p>These Thresholds address the contingency for a very rapid progression of events, such as that experienced on September 11, 2001. They are not premised solely on the potential for a radiological release. Rather, the issue includes the need for rapid assistance due to the possibility for significant and indeterminate damage from additional air, land or water attack elements.</p> <p>The fact that the site is under serious attack or is an identified attack target with minimal time available for further preparation or additional assistance to arrive requires a heightened state of readiness and implementation of protective measures that can be effective (such as on-site evacuation, dispersal or sheltering).</p> <p>Threshold #1</p> <p>This Threshold addresses the potential for a very rapid progression of events due to a HOSTILE ACTION. It is not intended to address incidents that are accidental events or acts of civil disobedience, such as small aircraft impact, hunters, or physical disputes between employees within the OCA. Those events are adequately addressed by other EALS.</p> <p>Note: that this EAL is applicable for any HOSTILE ACTION occurring, or that has occurred, in the OWNER CONTROLLED AREA. This includes ISFSIs that may be outside the PROTECTED AREA but still within the OWNER CONTROLLED AREA.</p> <p>Threshold #2</p> <p>This Threshold addresses the immediacy of an expected threat arrival or impact on the site within a relatively short time.</p> <p>The intent of this Threshold is to ensure that notifications for the airliner attack threat are made in a timely manner and that ORCs and plant personnel are at a state of heightened awareness regarding the credible threat. Airliner is meant to be a large aircraft with the potential for causing significant damage to the plant.</p> <p>This Threshold is met when a plant receives information regarding an airliner attack threat from NRC and the airliner is within 30 minutes of the plant. Only the plant to which the specific threat is made need declare the Alert.</p> <p>The NRC Headquarters Operations Officer (HOO) will communicate to the licensee if the threat involves an airliner (airliner is meant to be a large aircraft with the potential for causing significant damage to the plant). The status and size of the plane may be provided by NORAD through the NRC.</p> <p>HA5 – Basis:</p> <p>With the Control Room evacuated, additional support, monitoring and direction through the Technical Support Center and/or other emergency response facilities may be necessary.</p> <p>Inability to establish plant control from outside the Control Room will escalate this event to a Site Area Emergency.</p>	<p>HU4 – Basis:</p> <p>Note: Timely and accurate communication between Security Shift Supervision and the Control Room is crucial for the implementation of effective Security EALS.</p> <p>Security events which do not represent a potential degradation in the level of safety of the plant are reported under 10 CFR 73.71 or in some cases under 10 CFR 50.72. Security events assessed as HOSTILE ACTIONS are classifiable under HA4, HS4 and HG1.</p> <p>A higher initial classification could be made based upon the nature and timing of the security threat and potential consequences. The licensee shall consider upgrading the emergency response status and emergency classification level in accordance with the site's Physical Security Plan and Emergency Plan.</p> <p>Threshold #1</p> <p>Reference is made to security shift supervision because these individuals are the designated personnel on-site qualified and trained to confirm that a security event is occurring or has occurred. Training on security event classification confirmation is closely controlled due to the strict secrecy controls placed on the plant Physical Security Plan.</p> <p>Physical Security Plans are based on guidance provided by NEI 03-12.</p> <p>Threshold #2</p> <p>This threshold is included to ensure that appropriate notifications for the security threat are made in a timely manner. This includes information of a credible threat. Only the plant to which the specific threat is made need declare the Notification of an Unusual Event.</p> <p>The determination of "credible" is made through use of information found in the Physical Security Plan.</p> <p>Threshold #3</p> <p>The intent of this Threshold is to ensure that notifications for the aircraft threat are made in a timely manner and that ORCs and plant personnel are at a state of heightened awareness regarding the credible threat. It is not the intent of this threshold to replace existing non-hostile related Thresholds involving aircraft.</p> <p>This Threshold is met when a plant receives information regarding an aircraft threat from NRC. Validation is performed by calling the NRC or by other approved methods of authentication. Only the plant to which the specific threat is made need declare the Unusual Event.</p> <p>The NRC Headquarters Operations Officer (HOO) will communicate to the licensee if the threat involves an airliner (airliner is meant to be a large aircraft with the potential for causing significant damage to the plant). The status and size of the plane may be provided by NORAD through the NRC.</p> <p>Escalation to Alert emergency classification level would be via HA4 would be appropriate if the threat involves an airliner within 30 minutes of the plant.</p>
<p>H – HAZARDS AND OTHER CONDITIONS AFFECTING PLANT SAFETY</p>	<p>HS2 – Basis:</p> <p>The intent of this IC is to capture those events where control of the plant cannot be reestablished in a timely manner. In this case, expeditious transfer of control of safety systems has not occurred (although fission product barrier damage may not yet be indicated).</p> <p>The intent of the Threshold is to establish control of important plant equipment and knowledge of important plant parameters in a timely manner. Primary emphasis should be placed on those components and instruments that supply protection for and information about safety functions.</p> <p>These safety functions are reactivity control, RCS inventory, and secondary heat removal.</p> <p>The determination of whether or not control is established at the remote shutdown panel is based on Emergency Coordinator judgment. The Emergency Coordinator is expected to make a reasonable, informed judgment within the time for transfer that the licensee has control of the plant from the remote shutdown panel.</p> <p>Escalation of this emergency classification level, if appropriate, would be by Fission Product Barrier Degradation or Abnormal Rad Levels/Radiological Effluent EALS.</p>	<p>HA5 – Basis:</p> <p>With the Control Room evacuated, additional support, monitoring and direction through the Technical Support Center and/or other emergency response facilities may be necessary.</p> <p>Inability to establish plant control from outside the Control Room will escalate this event to a Site Area Emergency.</p>	<p>HA5 – Basis:</p> <p>With the Control Room evacuated, additional support, monitoring and direction through the Technical Support Center and/or other emergency response facilities may be necessary.</p> <p>Inability to establish plant control from outside the Control Room will escalate this event to a Site Area Emergency.</p>
<p>ATTACHMENT 2 - F-669 - REV 1 (EPIP-2010)</p> <p>TURKEY POINT CLASSIFICATION TABLE</p> <p>COLD CONDITIONS 23</p>	<p>COLD CONDITIONS 23</p>	<p>COLD CONDITIONS 23</p>	<p>COLD CONDITIONS 23</p>

H – HAZARDS AND OTHER CONDITIONS AFFECTING PLANT SAFETY

Recognition Category		H – HAZARDS AND OTHER CONDITIONS AFFECTING PLANT SAFETY				
<p>HG1 HOSTILE ACTION Resulting in Loss of Physical Control of the Facility.</p> <p>Operating Mode Applicability: All</p> <p>Threshold Values:</p> <ol style="list-style-type: none"> A HOSTILE ACTION has occurred such that plant personnel are unable to operate equipment required to maintain safety functions. <p>OR</p> <ol style="list-style-type: none"> A HOSTILE ACTION has caused failure of Spent Fuel Cooling Systems and IMMINENT fuel damage is likely for A FRESHLY OFF-LOADED REACTOR CORE in pool. 	<p>HS4 HOSTILE ACTION within the PROTECTED AREA</p> <p>Operating Mode Applicability: All</p> <p>Threshold Value:</p> <ol style="list-style-type: none"> A HOSTILE ACTION is occurring or has occurred within the PROTECTED AREA as reported by the Security Shift Supervisor. This threshold does not apply to a hostile action to the ISFSI Protected Area only. 	<p>HA4 HOSTILE ACTION within the OWNER CONTROLLED AREA or Airborne Attack Threat</p> <p>Operating Mode Applicability: All</p> <p>Threshold Values:</p> <ol style="list-style-type: none"> A HOSTILE ACTION is occurring or has occurred within the OWNER CONTROLLED AREA as reported by the Security Shift Supervisor. <p>OR</p> <ol style="list-style-type: none"> A validated notification from NRC of an airliner attack threat within 30 minutes of the site. 	<p>HU4 Confirmed SECURITY CONDITION or Threat Which indicates a Potential Degradation in the Level of Safety of the Plant.</p> <p>Operating Mode Applicability: All</p> <p>Threshold Values:</p> <ol style="list-style-type: none"> A SECURITY CONDITION that does NOT involve a HOSTILE ACTION as reported by the Security Shift Supervisor. <p>OR</p> <ol style="list-style-type: none"> A credible Turkey Point security threat notification. <p>OR</p> <ol style="list-style-type: none"> A validated notification from NRC providing information of an aircraft threat. 	<p>SECURITY</p>		
				<p>HS2 Control Room Evacuation Has Been Initiated and Plant Control Cannot be Established.</p> <p>Operating Mode Applicability: All</p> <p>Threshold Values:</p> <ol style="list-style-type: none"> a. Control Room evacuation has been initiated. <p>AND</p> <ol style="list-style-type: none"> Control of the plant cannot be established within 15 minutes. 	<p>HA5 Control Room Evacuation has been Initiated.</p> <p>Operating Mode Applicability: All</p> <p>Threshold Value:</p> <ol style="list-style-type: none"> 0-ONOP-105, Control Room Evacuation, requires Control Room evacuation. 	<p>CR EVACUATION</p>
				<p>UNUSUAL EVENT</p>		

Rec. Cat.	H2 – Basis:	Site Area Emergency	Alert	Unusual Event
H - HAZARDS AND OTHER CONDITIONS AFFECTING PLANT SAFETY	<p>H2 – Basis:</p> <p>This EAL addresses unanticipated conditions not addressed explicitly elsewhere but that warrant declaration of an emergency because conditions exist which are believed by the Emergency Coordinator to fall under the emergency classification level for General Emergency.</p>	<p>HS3 – Basis:</p> <p>This EAL addresses unanticipated conditions not addressed explicitly elsewhere but that warrant declaration of an emergency because conditions exist which are believed by the Emergency Coordinator to fall under the emergency classification level description for Site Area Emergency.</p>	<p>HA6 – Basis:</p> <p>This EAL addresses unanticipated conditions not addressed explicitly elsewhere but that warrant declaration of an emergency because conditions exist which are believed by the Emergency Coordinator to fall under the Alert emergency classification level.</p>	<p>HU5 – Basis:</p> <p>This EAL addresses unanticipated conditions not addressed explicitly elsewhere but that warrant declaration of an emergency because conditions exist which are believed by the Emergency Coordinator to fall under the Notification of Unusual Event (NOUE) emergency class.</p>

Recognition Category	H - HAZARDS AND OTHER CONDITIONS AFFECTING PLANT SAFETY			
DISCRETIONARY				
HG2	Other Conditions Existing Which in the Judgment of the Emergency Coordinator Warrant Declaration of General Emergency.	All	Operating Mode Applicability: All	Unusual Event
HS3	Other Conditions Existing Which in the Judgment of the Emergency Coordinator Warrant Declaration of Site Area Emergency.	All	Operating Mode Applicability: All	Alert
HA6	Other Conditions Existing Which in the Judgment of the Emergency Coordinator Warrant Declaration of an Alert.	All	Operating Mode Applicability: All	HU5
HU5	Other Conditions Existing Which in the Judgment of the Emergency Coordinator Warrant Declaration of a Notification of Unusual Event (NOUE).	All	Operating Mode Applicability: All	

HG2 Other Conditions Existing Which in the Judgment of the Emergency Coordinator Warrant Declaration of General Emergency.

HS3 Other Conditions Existing Which in the Judgment of the Emergency Coordinator Warrant Declaration of Site Area Emergency.

HA6 Other Conditions Existing Which in the Judgment of the Emergency Coordinator Warrant Declaration of an Alert.

HU5 Other Conditions Existing Which in the Judgment of the Emergency Coordinator Warrant Declaration of a Notification of Unusual Event (NOUE).

Operating Mode Applicability:
All

Operating Mode Applicability:
All

Operating Mode Applicability:
All

Operating Mode Applicability:
All

Threshold Value:
1. Other conditions exist which in the judgment of the Emergency Coordinator indicate that events are in progress or have occurred which involve actual or imminent substantial core degradation or melting with potential for loss of containment integrity or HOSTILE ACTION that results in an actual loss of physical control of the facility. Releases can be reasonably expected to exceed EPA Protective Action Guideline exposure levels off-site for more than the immediate site area.

Threshold Value:
1. Other conditions exist which in the judgment of the Emergency Coordinator indicate that events are in progress or have occurred which involve actual or likely major failures of plant functions needed for protection of the public or HOSTILE ACTION that results in intentional damage or malicious acts; (1) toward site personnel or equipment that could lead to the likely failure of; (2) that prevent effective access to equipment needed for the protection of the public. Any releases are not expected to result in exposure levels which exceed EPA Protective Action Guideline exposure levels beyond the site boundary.

Threshold Value:
1. Other conditions exist which in the judgment of the Emergency Coordinator indicate that events are in progress or have occurred which involve actual or likely major failures of plant functions needed for protection of the public or HOSTILE ACTION that results in intentional damage or malicious acts; (1) toward site personnel or equipment that could lead to the likely failure of; (2) that prevent effective access to equipment needed for the protection of the public. Any releases are not expected to result in exposure levels which exceed EPA Protective Action Guideline exposure levels beyond the site boundary.

Threshold Value:
1. Other conditions exist which in the judgment of the Emergency Coordinator indicate that events are in progress or have occurred which involve actual or imminent substantial core degradation or melting with potential for loss of containment integrity or HOSTILE ACTION that results in an actual loss of physical control of the facility. Releases can be reasonably expected to exceed EPA Protective Action Guideline exposure levels off-site for more than the immediate site area.

DEFINITION BOX

HOSTILE ACTION – An act toward a Nuclear Power Plant (NPP) or its personnel that includes the use of violent force to destroy equipment, take HOSTAGES, or otherwise impede the licensee to achieve an end. This includes attack by air, land, or water using guns, explosives, PROJECTILES, vehicles, or other devices used to deliver destructive force. Other acts that satisfy the overall intent may be included. HOSTILE ACTION should not be construed to include acts of civil disobedience or felonious acts that are not part of a concerted attack on the NPP. Non-terrorism-based EALS should be used to address such activities (i.e., this may include violent acts between individuals in the owner controlled area).

IMMINENT – Mitigation actions have been ineffective, additional actions are not expected to be successful, and trended information indicates that the event or condition will occur. Where IMMINENT timeframes are specified, they shall apply.

PROJECTILE – An object directed toward a Nuclear Power Plant (NPP) that could cause concern for its continued operability, reliability, or personnel safety.

This Page Intentionally Left Blank

RECOGNITION CATEGORY E EVENTS RELATED TO ISFSI

Rec. Cat.	Site Area Emergency	Alert	Unusual Event
E - EVENTS RELATED TO ISFSI		<p>DEFINITION BOX</p> <p>CONFINEMENT BOUNDARY - The barrier(s) between areas containing radioactive substances and the environment.</p> <p>EXPLOSION - A rapid, violent, unconfined combustion, or catastrophic failure of pressurized/energized equipment that imparts energy or sufficient force to potentially damage permanent structures, systems, or components.</p> <p>FIRE - Combustion characterized by heat and light. Sources of smoke such as slipping drive belts or overheated electrical equipment do not constitute FIRES. Observation of flame is preferred but is NOT required if large quantities of smoke and heat are observed.</p> <p>PROJECTILE - An object directed toward a Nuclear Power Plant (NPP) that could cause concern for its continued operability, reliability, or personnel safety.</p>	<p>E-HU1 - Basis:</p> <p>A Notification of Unusual Event (NOUE) in this IC is categorized on the basis of the occurrence of an event of sufficient magnitude that a loaded cask CONFINEMENT BOUNDARY is damaged or violated. This includes classification based on a loaded fuel storage cask CONFINEMENT BOUNDARY loss leading to the degradation of the fuel during storage or posing an operational safety problem with respect to its removal from storage as indicated by elevated radiation readings from the loaded fuel storage cask.</p> <p>The results of the (ISFSI) Safety Analysis Report (SAR) per NUREG, 1536 or SAR referenced in the cask's Certificate of Compliance and the related NRC Safety Evaluation Report identify natural phenomena events and accident conditions that could potentially affect the CONFINEMENT BOUNDARY. This EAL addresses a dropped cask, a tipped over cask, EXPLOSION, PROJECTILE damage, FIRE damage or natural phenomena affecting a cask (e.g., seismic event, tornado, etc.).</p>

Recognition Category	E - EVENTS RELATED TO ISFSI	
	ISFSI	
Unusual Event	Site Area Emergency	Alert
E-HU1	Damage to a loaded cask CONFINEMENT BOUNDARY.	<p data-bbox="261 1087 285 1260">Operating Mode Applicability: Not applicable</p> <p data-bbox="261 1260 285 1407">Threshold Value:</p> <p data-bbox="261 1407 285 1963">1. Damage to a loaded cask CONFINEMENT BOUNDARY.</p>
		<p data-bbox="285 1087 293 1260">DEFINITION BOX.</p> <p data-bbox="293 1087 438 1963">CONFINEMENT BOUNDARY – The barrier(s) between areas containing radioactive substances and the environment.</p>

This Page Intentionally Left Blank

ATTACHMENT TO L-2011-535

Turkey Point

Questions 1-75 RO

Questions 76-100 SRO only

Examination Answer Key December 14, 2011

1	D	26	B	51	D	76	B
2	A	27	A	52	A	77	A
3	B	28	B	53	B	78	A
4	D	29	B	54	A	79	C
5	A	30	D	55	B	80	A
6	A	31	D	56	C	81	B
7	B	32	B	57	C	82	A
8	C	33	C	58	C	83	A
9	C	34	C	59	B	84	B
10	C	35	B	60	A	85	B
11	A	36	C	61	A/D	86	D
12	D	37	A	62	C	87	A
13	D	38	B	63	A	88	D
14	D	39	C	64	D	89	D
15	C	40	B	65	C	90	D
16	C	41	B	66	A	91	C
17	B	42	C	67	C	92	A
18	B	43	A	68	C	93	D
19	C	44	C	69	C	94	B
20	A	45	C	70	D	95	C
21	B	46	D	71	C	96	D
22	D	47	D	72	D	97	B
23	D	48	D	73	A	98	C
24	C	49	D	74	D	99	D
25	C	50	A	75	D	100	C

Facility: Turkey Point
Vendor: WEC
Exam Date: 2011
Exam Type: SRO ONLY

Examination Outline Cross-reference:	Level	RO	SRO
	Tier #		1
	Group #		1
	K/A #	008	AA2.30
	Importance Rating		4.7

Ability to determine and interpret the following as they apply to the Pressurizer Vapor Space Accident: Inadequate core cooling

Proposed Question: SRO Question # 76

The following conditions exist:

- Unit 3 tripped from 100% power due to a Loss of All Feedwater.
- All HHSI Pumps are unavailable.
- The Unit 3 PORVs are cycling.

After 30 minutes into this event:

- The crew has not been able to restore any feedwater to all S/Gs.
- Unit 3 S/G Wide Range Levels are all at 5%.
- Seven of the highest Core Exit Thermocouples (CETs) are rising and temperatures are as follows: 2200°F, 2210°F, 1210°F, 1207°F, 1201°F, 1170°F, and 1151°F.
- RVLMS Plenum indicates 0%.
- CHRRMS is 2.0E4 R/hr.

Which ONE of the following describes the (1) required functional restoration procedure to immediately transition to and (2) highest required emergency classification?

REFERENCE PROVIDED

- A. (1) 3-EOP-FR-C.2, Response to Degraded Core Cooling
(2) Site Area Emergency

- B. (1) 3-EOP-FR-C.1, Response to Inadequate Core Cooling
(2) General Emergency
- C. (1) 3-EOP-FR-C.2, Response to Degraded Core Cooling
(2) General Emergency
- D. (1) 3-EOP-FR-C.1, Response to Inadequate Core Cooling
(2) Site Area Emergency

Proposed Answer: B

Explanation (Optional):

- A. Incorrect. 5 CETs are greater than 1200°F; therefore the correct priority is 3-EOP-FR-C.1. Plausibility – Student must count all CET instruments which leads to 3-EOP-FR.C.1. If the operator believes he doesn't have to count the failed CETs then he would determine he was in an Orange Path vice a RED Path for Core Cooling. SAE plausible because if the student miscounts failed barriers he would be directed towards a SAE vice a GE in classification.
- B. Correct.
- C. Incorrect. 5 CETs are greater than 1200°F; therefore the correct priority is 3-EOP-FR-C.1. Plausibility Student must count all CET instruments which leads to 3-EOP-FR.C.1. If the operator believes he doesn't have to count the failed CETs then he would determine he was in an Orange Path vice a RED Path for Core Cooling. Also, plausible because 2nd part is correct.
- D. Incorrect, The wrong procedure actions are selected. Plausibility – RCPs are operated in 3-EOP-FR-C.1. The RCP is only started after RCS temperatures continue to rise at Step 19. SAE plausible because if the student miscounts failed barriers he would be directed towards a SAE vice a GE in classification.

Technical Reference(s): 3-EOP-F-0 (Attach if not previously provided)
3-EOP-FR.C.1
3-EOP-FR.C.2

Proposed References to be provided to applicants during examination: F668 and F669

Learning Objective:

(As available)

Question Source: Bank #

Modified Bank #

(Note changes or attach parent)

New

X

Question History:

Last NRC Exam:

Question Cognitive Level: Memory or Fundamental Knowledge

Comprehension or Analysis

(3SPK)

Question Difficulty Level: B

10 CFR Part 55 Content: 55.41

55.43 5

Assessment of facility conditions and selection of appropriate procedures during normal, abnormal, and emergency situations.

Comments:

Matches KA because the applicant must determine and interpret if inadequate core cooling condition exists and prioritize the best mitigation strategy during a vapor space break.

Facility: Turkey Point
 Vendor: WEC
 Exam Date: 2011
 Exam Type: SRO ONLY

Examination Outline Cross-reference:	Level	RO	SRO
	Tier #		1
	Group #		1
	K/A #	011	2.4.9
	Importance Rating		4.2

(Large Break LOCA) Emergency Procedures / Plan: Knowledge of low power / shutdown implications in accident (e.g., loss of coolant accident or loss of residual heat removal) mitigation strategies.

Proposed Question: SRO Question # 77

Unit 3 is in MODE 5 and drained down for Reduced Inventory Operations with the following:

- The RCS is depressurized at 100°F.
- RCS Heatup Rate is 9°F/ hr.
- S/G 3A, 3B and 3C Narrow Range Levels are at 20%.
- The Equipment Hatch is open.
- The following alarms are received in the Control Room:
 - H 6/2, RHR HX HI/LO FLOW
 - I 8/6, RHR SUMP PUMP ROOM A HI LEVEL.
- PZR Cold Cal Level, LI-3-462 is off-scale low.
- PZR Drain Down Levels, LI-3-6421 and LI-3-6423, are 12% and stable.
- RHR Pump 3A was manually tripped in 3-ONOP-050, Loss of RHR.

Which ONE of the following describes (1) if 3-ONOP-041.8 Shutdown LOCA [Mode 5 or 6], Attachment 2, Feed and Bleed Cooling, is required (2) and the highest required emergency classification?

REFERENCE PROVIDED

- A. (1) is required
(2) Site Area Emergency
- B. (1) is required
(2) Alert

- C. (1) is not required
(2) Site Area Emergency
- D. (1) is not required
(2) Alert

Proposed Answer: A

Explanation (Optional):

- A. CORRECT. They perform Attachment 2 to initiate Feed and Bleed RCS cooling. The event is classified as a Site Area Emergency by EAL CS1.
- B. Incorrect because this is the wrong EAL. The event is a SAE and not an Alert by EAL CA1. Plausible because Attachment 2 is required to establish feed and bleed cooling.
- C. Incorrect since this procedure body is not the correct mitigation strategy for a Shutdown LOCA when in MODE 5 or 6. Plausible because the actions are possible under different conditions in 3-ONOP-041.8. Also plausible because the classification is proper.
- D. Incorrect since this classification is improper and the mitigation strategy for a Shutdown LOCA when in MODE 5 or 6 requires using Attachment 2. However, with the reduced inventory status of RCS level, 3-ONOP-041.8 cools the RCS by use of Feed and Bleed.

Technical Reference(s): 3-ONOP-041.8, Shutdown LOCA (Attach if not previously provided)
 [Mode 5 or 6]
 3-ONOP-050, Loss of RHR

Proposed References to be provided to applicants during examination: F668 and F669

Learning Objective: None (As available)

Question Source: Bank #
 Modified Bank # (Note changes or attach parent)
 New X

Question History: Last NRC Exam:

Question Cognitive Level: Memory or Fundamental Knowledge
 Comprehension or Analysis (3SPR)

Question Difficulty Level: B

10 CFR Part 55 Content: 55.41

55.43 5

Assessment of facility conditions and selection of appropriate procedures during normal, abnormal, and emergency situations.

Comments:

K/A Match Justification:

This question matches the K/A in that it tests knowledge of the parameters (RCS inventory loss) used to assess the status of safety functions, such as core cooling and heat removal, during a Loss of RHR.

SRO ONLY Justification:

From SRO Only guidance:

Assessment of facility conditions and selection of appropriate procedures during normal, abnormal, and emergency situations. [10 CFR 55.43(b)(5)]

This 10 CFR 55.43 topic involves both 1) assessing plant conditions (normal, abnormal, or emergency) and then 2) selecting a procedure or section of a procedure to mitigate, recover, or with which to proceed. One area of SRO level knowledge (with respect to selecting a procedure) is knowledge of the content of the procedure versus knowledge of the procedure's overall mitigative strategy or purpose.

The applicant's knowledge can be evaluated at the level of 10 CFR 55.43(b)(5) by ensuring that the additional knowledge of the procedure's content is required to correctly answer the written test item, for example:

- Knowledge of when to implement attachments and appendices, including how to coordinate these items with procedure steps.
- Knowledge of diagnostic steps and decision points in the emergency operating procedures (EOP) that involve transitions to event specific subprocedures or emergency contingency procedures.
- Knowledge of administrative procedures that specify hierarchy, implementation, and/or coordination of plant normal, abnormal, and emergency procedures.

Facility: Turkey Point
Vendor: WEC
Exam Date: 2011
Exam Type: SRO ONLY

Examination Outline Cross-reference:	Level	RO	SRO
	Tier #		1
	Group #		1
	K/A #	025	2.4.21
	Importance Rating		4.6

(Loss of RHR) Emergency Procedures / Plan: Knowledge of the parameters and logic used to assess the status of safety functions, such as reactivity control, core cooling and heat removal, reactor coolant system integrity, containment conditions, radioactivity release control, etc.

Proposed Question: SRO Question # 78

A Unit 3 RCS cooldown is in progress with the following:

- Unit 3 was shutdown 5 days ago.
- RCS Temperature is 105°F.
- RCS Pressure is 160 psig.
- RHR Pump 3A is in service.
- RHR Pump 3B is in Standby.
- CCW Pump 3C is out of service.
- Pressurizer level is 22%.
- S/G levels are 35% Narrow Range on all three S/Gs.

When,

- RHR Pump 3A trips.
- RHR Pump 3B is started.
- RCS Temperature is 115 °F.
- RCS Pressure is maintained greater than 150 psig.

In accordance with ADM-051, Outage Risk Assessment and Control, which ONE of the following is (1) the Enclosure that identifies the required Unit 3 Contingency Actions for Decay Heat Removal, given the initial plant status, and (2) the required Safe Shutdown Function Color Code for Decay Heat Removal AFTER the 3A RHR Pump tripped?

- A. (1) **Enclosure 1**, Minimum Required Equipment, Phase I, Large Decay Heat Load and RCS Temp Less Than 200 Degrees with RCS Loops Filled
(2) Orange
- B. (1) **Enclosure 2**, Minimum Required Equipment, Phase I, Large Decay Heat Load and RCS Temp Less Than 200 Degrees without RCS Loops Available
(2) Red

- C. (1) **Enclosure 1**, Minimum Required Equipment, Phase I, Large Decay Heat Load and RCS Temp Less Than 200 Degrees with RCS Loops Filled
(2) Red
- D. (1) **Enclosure 2**, Minimum Required Equipment, Phase I, Large Decay Heat Load and RCS Temp Less Than 200 Degrees without RCS Loops Available
(2) Orange

Proposed Answer: A

Explanation (Optional):

- A. CORRECT. RCS Loops are filled and available since RCS Pressure is at 150 psig. Also, one RHR Pump is out of service which is a classification of the Safe Shutdown Function Color Code of Orange.
- B. Incorrect because **Enclosure 2**, Minimum Required Equipment, Phase I, Large Decay Heat Load and RCS Temp Less Than 200 Degrees without RCS Loops Available is the wrong enclosure. Plausible since RCS pressure is low and a loss of a RHR Pump is top priority for restoration which is assumed to be a Red Safe Shutdown Function Color Code.
- C. Incorrect because a loss of a RHR Pump is an Orange Safe Shutdown Function Color Code. Plausible since RCS pressure is low and a loss of a RHR Pump is top priority for restoration which is assumed to be a Red Safe Shutdown Function Color Code.
- D. Incorrect because **Enclosure 2**, Minimum Required Equipment, Phase I, Large Decay Heat Load and RCS Temp Less Than 200 Degrees without RCS Loops Available is the wrong enclosure. Plausible since a loss of a RHR Pump is top priority for restoration which is an Orange Safe Shutdown Function Color Code.

Technical Reference(s): ADM-051 Enclosure 1 & 2 (Attach if not previously provided)

Proposed References to be provided to applicants during examination: None

Learning Objective: None (As available)

Question Source: Bank #
 Modified Bank # (Note changes or attach parent)
 New X

Question History: Last NRC Exam:

Question Cognitive Level: Memory or Fundamental Knowledge
Comprehension or Analysis (2DR)

Question Difficulty Level: B

10 CFR Part 55 Content: 55.41
55.43 5

Assessment of facility conditions and selection of appropriate procedures during normal, abnormal, and emergency situations.

Comments:

K/A Match Justification:

This question matches the K/A in that it tests knowledge of the parameters (RCS inventory loss) used to assess the status of safety functions, such as core cooling and heat removal, during a Loss of RHR.

SRO ONLY Justification:

From SRO Only guidance:

Assessment of facility conditions and selection of appropriate procedures during normal, abnormal, and emergency situations. [10 CFR 55.43(b)(5)]

This 10 CFR 55.43 topic involves both 1) assessing plant conditions (normal, abnormal, or emergency) and then 2) selecting a procedure or section of a procedure to mitigate, recover, or with which to proceed. One area of SRO level knowledge (with respect to selecting a procedure) is knowledge of the content of the procedure versus knowledge of the procedure's overall mitigative strategy or purpose.

The applicant's knowledge can be evaluated at the level of 10 CFR 55.43(b)(5) by ensuring that the additional knowledge of the procedure's content is required to correctly answer the written test item, for example:

- Knowledge of when to implement attachments and appendices, including how to coordinate these items with procedure steps.
- Knowledge of diagnostic steps and decision points in the emergency operating procedures (EOP) that involve transitions to event specific subprocedures or emergency contingency procedures.
- Knowledge of administrative procedures that specify hierarchy, implementation, and/or coordination of plant normal, abnormal, and emergency procedures.

Facility: Turkey Point
Vendor: WEC
Exam Date: 2011
Exam Type: SRO ONLY

Examination Outline Cross-reference:	Level	RO	SRO
	Tier #		1
	Group #		1
	K/A #	056	AA2.53
	Importance Rating		3.2

Ability to determine and interpret the following as they apply to the Loss of Offsite Power:
Status of emergency bus under voltage relays

Proposed Question: SRO Question # 79

Unit 3 is in MODE 1.

Which ONE of the following completes the statements below?

A failure of a 3A 4KV Bus Loss of Voltage Relay (ESFAS) is indicated by (1).

NOTE: For the next statement assume NO surveillance testing and no relay actuation occurred

In accordance with Technical Specifications, if TWO 4KV Bus Loss of Voltage Relays are inoperable, then (2).

REFERENCE PROVIDED

- A. (1) an amber light (PL-11) at Sequencer Panel 3C23A is OFF
(2) within 6 hours, place the failed relay in the tripped condition
- B. (1) Annunciator X2/1, 4KV BUS 3A LO VOLTAGE, is LIT
(2) within 6 hours, place the failed relay in the tripped condition
- C. (1) an amber light (PL-11) at Sequencer Panel 3C23A is OFF
(2) within 1 hour, initiate action to place the unit in at least HOT STANDBY within the next 6 hours

- D. (1) Annunciator X2/1, 4KV BUS 3A LO VOLTAGE, is LIT
- (2) within 1 hour, initiate action to place the unit in at least HOT STANDBY within the next 6 hours

Proposed Answer: C

Explanation (Optional):

- A. Incorrect because the action is for a different ESFAS channel failure (Action 17)
Plausible because the first part is correct.
- B. Incorrect because Annunciator X2/1, 4KV BUS 3A LO VOLTAGE, setpoint at 3325 VAC is not use indicative of a bus undervoltage (2975 VAC). Plausible since the LO Voltage relay gives an alarm associated with the bus. Also correct action
- C. CORRECT. RO Daily Logs, 3-OSP-201.1, check the amber light (PL-11) at Sequencer Panel 3C23A is ON to satisfy TS 3.3.2 FU 7.a. Action 18
- D. Incorrect because Annunciator X2/1, 4KV BUS 3A LO VOLTAGE, setpoint at 3325 VAC is not use indicative of a bus undervoltage (2975 VAC). Plausible since the LO Voltage relay gives an alarm associated with the bus.

ACTION 18 - With the number of OPERABLE channels one less than the Total Number of Channels, STARTUP and/or POWER OPERATION may proceed provided the inoperable channel is placed in the tripped condition within 6 hours. Both channels of any one load center may be taken out of service for up to 6 hours in order to perform surveillance testing per Specification 4.3.2.1.

Technical Reference(s): TS Table 4.3-2, Engineered Safety Features Actuation System Instrumentation Surveillance Requirements (Attach if not previously provided)
 0-ADM-218
 3-OSP-201.1, pg. 31
 3-ARP-097.CR.X, X2/1
 5613-E-3 Sheet 11

Proposed References to be provided to applicants during examination: T.S. pages 119, 125 (function 7 only), 126,127 and128

Learning Objective: LP 6902157, Obj. 11 (As available)

Question Source: Bank #
 Modified Bank # (Note changes or attach parent)
 New X

Question History:

Last NRC Exam:

Question Cognitive Level: Memory or Fundamental Knowledge (1F)
Comprehension or Analysis

Question Difficulty Level: B

10 CFR Part 55 Content: 55.41

55.43 2

Facility operating limitations in the technical specifications and their bases.

Comments:

K/A Match Justification:

This question matches the K/A in that it tests how to check the status of the Loss of Voltage relays that are used to sense a Loss of Offsite Power, including the surveillance requirements that check the operability of those relays.

SRO Only Justification:

This question is SRO Only because it satisfies the guidance in the "SRO Only document," Page 3, as highlighted below:

B. Facility operating limitations in the TS and their bases. [10 CFR 55.43(b)(2)]

Some examples of SRO exam items for this topic include:

- Application of Required Actions (Section 3) and Surveillance Requirements (SR) (Section 4) in accordance with rules of application requirements (Section 1).

Facility: Turkey Point
 Vendor: WEC
 Exam Date: 2011
 Exam Type: SRO ONLY

Examination Outline Cross-reference:	Level	RO	SRO
	Tier #		1
	Group #		1
	K/A #	038	2.2.44
	Importance Rating		4.4

Equipment Control: Ability to interpret control room indications to verify the status and operation of a system, and understand how operator actions and directives affect plant and system conditions.

Proposed Question: SRO Question # 80

Given the following:

- Unit 4 experienced a Steam Generator Tube Rupture (SGTR) from 100% power.
- Containment temperature on TE-4-6700, TE-4-6701, and TE-4-6702 is 135°F and rising.
- The operating crew is implementing 4-EOP-E-3, Steam Generator Tube Rupture.
- The crew stopped the RCS cooldown and verified the ruptured S/G pressure is increasing slowly.
- QSPDS CET Subcooling is 70°F.
- Instrument Air to Containment has been lost, and CANNOT be established.

Which ONE of the choices below completes the following statements?

In order to remain in 4-EOP-E-3, Steam Generator Tube Rupture, RCS subcooling is required to be greater than (1).

If below the required RCS Subcooling for 4-EOP-E-3, then transition to (2).

- A. (1) 50°F
(2) 4-EOP-ECA-3.1, SGTR with Loss of Reactor Coolant, Subcooled Recovery Desired
- B. (1) 100°F
(2) 4-EOP-ECA-3.1, SGTR with Loss of Reactor Coolant, Subcooled Recovery Desired
- C. (1) 50°F

(2) 4-EOP-ECA-3.3, SGTR without Pressurizer Pressure Control

- D. (1) 100°F
(2) 4-EOP-ECA-3.3, SGTR without Pressurizer Pressure Control

Proposed Answer: *A based on post exam comment*

*BUC
1/4/12*

Explanation (Optional):

- A. Incorrect since the proper transition is to 4-EOP-ECA-3.3, not 4-EOP-ECA-3.1. Plausible because the 1st part is correct. Also plausible because 4-EOP-ECA-3.1 would be entered for RCS cooldown if PZR Pressure Control was available. In this case, PZR PORVs, Spray and Aux Spray are lost due to loss of IA to containment.
- B. Incorrect since the minimum subcooling under these conditions is 50°F, not 100°F. Plausible because 4-EOP-ECA-3.1 would be entered for RCS cooldown if all PZR Pressure Control was available. In this case, PZR PORVs, Spray and Aux Spray are lost due to loss of IA to containment. Also plausible because the 1st part would be correct if adverse containment conditions existed.
- C. CORRECT
- D. Incorrect since the minimum subcooling under these conditions is 50°F, not 100°F. Also plausible because the 2nd part is correct.

LP 6902339, Steam Generator
Tube Rupture

Technical Reference(s): 4-EOP-E-3, Steam Generator Tube Rupture (Attach if not previously provided)

Proposed References to be provided to applicants during examination: None

Learning Objective: LP 6902339, Obj. 6 (As available)

Question Source: Bank #
Modified Bank # (Note changes or attach parent)
New X

Question History:

Last NRC Exam:

Question Cognitive Level: Memory or Fundamental Knowledge (1P)
Comprehension or Analysis

Question Difficulty Level: B

10 CFR Part 55 Content: 55.41

55.43 5

Assessment of facility conditions and selection of appropriate procedures during normal, abnormal, and emergency situations.

Comments:

K/A Match Justification:

This question matches the K/A in that it tests ability to monitor CR indications (subcooling) to verify the status of a system (RCS) and understanding of how actions (go to 4-EOP-ECA-3.1) affect the plant.

SRO ONLY Justification:

From SRO Only guidance:

Assessment of facility conditions and selection of appropriate procedures during normal, abnormal, and emergency situations. [10 CFR 55.43(b)(5)]

This 10 CFR 55.43 topic involves both 1) assessing plant conditions (normal, abnormal, or emergency) and then 2) selecting a procedure or section of a procedure to mitigate, recover, or with which to proceed. One area of SRO level knowledge (with respect to selecting a procedure) is knowledge of the content of the procedure versus knowledge of the procedure's overall mitigative strategy or purpose.

The applicant's knowledge can be evaluated at the level of 10 CFR 55.43(b)(5) by ensuring that the additional knowledge of the procedure's content is required to correctly answer the written test item, for example:

- Knowledge of when to implement attachments and appendices, including how to coordinate these items with procedure steps.
- Knowledge of diagnostic steps and decision points in the emergency operating procedures (EOP) that involve transitions to event specific sub-procedures or emergency contingency procedures.
- Knowledge of administrative procedures that specify hierarchy, implementation, and/or coordination of plant normal, abnormal, and emergency procedures.

Facility: Turkey Point
Vendor: WEC
Exam Date: 2011
Exam Type: SRO ONLY

Examination Outline Cross-reference:	Level	RO	SRO
	Tier #		1
	Group #		1
	K/A #	E04	EA2.1
	Importance Rating		4.3

Ability to determine and interpret the following as they apply to the (LOCA Outside Containment) Facility conditions and selection of appropriate procedures during abnormal and emergency operations.

Proposed Question: SRO Question # 81

The following conditions exist:

3-EOP-ECA-1.2, LOCA Outside Containment is in progress. MOV-3-744A/B, RHR Discharge to Cold Leg Isolation Valves, have been closed.

- RCS pressure indicates 1440 psig and rising.
- RCS temperature is 525°F and stable.
- Pressurizer level is 20% and rising.
- All ECCS equipment is running as required.
- RWST Level is 290,000 gallons and slowly lowering.
- AFW flow is 350 GPM.

Which ONE of the following identifies the required procedure sequence for the above plant conditions?

- A. 3-EOP-ECA-1.1, Loss of Emergency Coolant Recirculation → 3-EOP-E-1, Loss of Reactor or Secondary Coolant → 3-EOP-ES-1.1, SI Termination
- B. 3-EOP-E-1, Loss of Reactor or Secondary Coolant → 3-EOP-ES-1.1, SI Termination
- C. 3-EOP-ECA-1.1, Loss of Emergency Coolant Recirculation → 3-EOP-E-1, Loss of Reactor or Secondary Coolant → 3-EOP-ES-1.2, Post-LOCA Cooldown and Depressurization
- D. 3-EOP-E-1, Loss of Reactor or Secondary Coolant → 3-EOP-ES-1.2, Post-LOCA Cooldown and Depressurization

Proposed Answer: B

Explanation (Optional):

- A. Incorrect. Leak is isolated. Transition should be to 3-EOP-E-1 since RCS pressure is rising
- B. CORRECT. The SRO should transition to 3-EOP-E-1 based on RCS pressure rising, then will go to ES-1.1 to terminate SI.
- C. Incorrect. The strategy is to isolate the leak, verify isolation, and return to 3-EOP-E-1 for these conditions. Plausible because 3-EOP-ECA-1.1 is the correct procedure to transition to if RCS pressure is stable or lowering
- D. Incorrect. The conditions are met for transition to 3-EOP-E-1. However, a post LOCA cooldown and depressurization is not necessary due to isolation of the leak. Plausible because 3-EOP-EOP-E-1 is the correct procedure.

Technical Reference(s): 3-EOP-ECA-1.2
3-EOP-E-1 (Attach if not previously provided)

Proposed References to be provided to applicants during examination: None

Learning Objective: LP 6900333 Obj 6 (As available)

Question Source: Bank #
Modified Bank # WTSI 66716 (Note changes or attach parent)
New

Question History: Last NRC Exam:

Question Cognitive Level: Memory or Fundamental Knowledge
Comprehension or Analysis (3SPK)

Question Difficulty: Moderate (B)

10 CFR Part 55 Content: 55.41
55.43 5

Assessment of facility conditions and selection of appropriate procedures during normal, abnormal, and emergency situations.

Comments:

Modified from 2009 Turkey Point Exam. Changed conditions in stem and changed correct answer. Modified other distracters for plausibility of conditions

Facility: Turkey Point
 Vendor: WEC
 Exam Date: 2007
 Exam Type: SRO ONLY

Examination Outline Cross-reference:	Level	RO	SRO
	Tier #		1
	Group #		2
	K/A #	001	AA2.05
	Importance Rating		4.6

Ability to determine and interpret the following as they apply to the Continuous Rod Withdrawal:
 Uncontrolled rod withdrawal, from available indications

Proposed Question: SRO Question # 82

Unit 3 is raising power from 50% to 100% power at 10%/hr by boron dilution and rod withdrawal with the following initial conditions:

- Reactor Power 85%.
- Control Bank D Rods 200 steps with Rod Control in Manual.
- 30 minutes ago, a 200 gallon dilution to the RCS was performed over 3 minutes.

Subsequently,

- The RO momentarily placed the In/Out/Hold Switch to OUT.
- TAVG/TAVG – TREF DEVIATION (B 4/4) annunciator began alarming.
- Reactor power is currently 87% and rising slowly.
- VCT level has remained stable at 32% for the last 15 minutes.

Which ONE of the following identifies (1) the event in progress, and (2) the bases for the RPS trip designed for this event in accordance with the UFSAR?

- A. (1) Uncontrolled Rod Withdrawal
 (2) Minimizes the impact on hot channel factors, $F_Q(Z)$ and $F_{\Delta h}^N$
- B. (1) Uncontrolled Rod Withdrawal
 (2) Prevents Axial Flux Difference (AFD) from exceeding TS limits

- C. (1) Unplanned Dilution Event
(2) Minimizes the impact on hot channel factors, $F_Q(Z)$ and $F_{\Delta h}^N$
- D. (1) Unplanned Dilution Event
(2) Prevents Axial Flux Difference (AFD) from exceeding TS limits

Proposed Answer: A

Explanation (Optional):

- A. Correct. Correct event. Bases is IAW T.S.
- B. Incorrect. Plausibility - Correct event. Plausible because AFD will be affected. Incorrect since AFD will not result in exceeding limits at 200 steps.
- C. Incorrect. Plausibility - Incorrect event. The candidate should realize VCT level will increase for a constant rate dilution. For a over dilution (batch) event, they will understand diluting 200 gallons (enough for 1% increase) which is about ten times the water used for temperature control at 100% power. Also, plausible because the correct reason is listed to minimize the impact on power distribution limits
- D. Incorrect. Plausibility - Incorrect event. The candidate should realize VCT level will increase for a constant rate dilution. For a over dilution (batch) event, they will understand diluting 200 gallons (enough for 1% increase) which is about ten times the water used for temperature control at 100% power. Also, plausible because AFD will be affected.

Technical Reference(s): 3-ONOP-028 (Attach if not previously provided)

Proposed References to be provided to applicants during examination: None

Learning Objective: None Found (No LP for this procedure?) (As available)

Question Source: Bank #
Modified Bank # WTSI 68772 (Note changes or attach parent)
New

Question History: Last NRC Exam:

Question Cognitive Level: Memory or Fundamental Knowledge
Comprehension or Analysis (2DR)

Question Difficulty Level: B

10 CFR Part 55 Content: 55.41 5
55.43

Facility operating characteristics during steady state and transient conditions, including coolant chemistry, causes and effects of temperature, pressure and reactivity changes, effects of load changes, and operating limitations and reasons for these operating characteristics.

Comments: Modified from VC Summer 2007 exam

Facility: Turkey Point
 Vendor: WEC
 Exam Date: 2011
 Exam Type: SRO ONLY

Examination Outline Cross-reference:	Level	RO	SRO
	Tier #		1
	Group #		2
	K/A #	069	2.4.41
	Importance Rating		4.6

Emergency Procedures / Plan: Knowledge of the emergency action level thresholds and classifications.

Proposed Question: SRO Question # 83

Given the following:

Unit 3 has experienced a Large Break Loss of Coolant Accident (LOCA) from 100% power.

The operating crew notes the following parameters:

- Containment pressure is 38 psig.
- Containment temperature is 220°F.
- 4A HHSI Pump is running.
- 3A Containment Spray Pump is running.
- All other ECCS equipment is TRIPPED and CANNOT be started.
- All 3 Emergency Containment Coolers are TRIPPED.
- QSPDS CET Subcooling is (-) 38°F.
- CHRRMs are reading 1.3E5 R/hr.
- RAD-6304, Plant Vent SPING, reads 5.0E-1 µC/cc for 20 minutes.
- Dose assessments based on field measurements indicate dose at the Site Area Boundary is 150 mRem TEDE.
- Wind Speed is 6 mph.
- Wind Direction is 236°

Which ONE of the following below completes the table for the MINIMUM Protective Action Recommendations (PARs) for the above conditions?

REFERENCES PROVIDED

A.

<u>Miles</u>	<u>Evacuate Sectors</u>	<u>Shelter Sectors</u>	<u>No Action Sectors</u>
0-2	ALL	None	None
2-5	BCDE	All Remaining	None
5-10	None	ALL	None

B.

<u>Miles</u>	<u>Evacuate Sectors</u>	<u>Shelter Sectors</u>	<u>No Action Sectors</u>
0-2	ALL	None	None
2-5	BCD	All Remaining	None
5-10	None	ALL	None

C.

<u>Miles</u>	<u>Evacuate Sectors</u>	<u>Shelter Sectors</u>	<u>No Action Sectors</u>
0-2	None	All	None
2-5	None	BCDE	All Remaining
5-10	None	None	ALL

D.

<u>Miles</u>	<u>Evacuate Sectors</u>	<u>Shelter Sectors</u>	<u>No Action Sectors</u>
0-2	None	All	None
2-5	None	BCD	All Remaining
5-10	None	None	ALL

Proposed Answer: A

Explanation (Optional):

- A. Correct
- B. Incorrect. This does not include ALL correct sectors for wind direction. Question is plausible if the student does not recognize the wind direction is on the edge between to sectors.
- C. Incorrect. Plausibility- student may not recognize that this is an event with fuel damage and uses PARs for an event without fuel damage.
- D. Incorrect. Plausibility- student may not recognize that this is an event with fuel damage and uses PARs for an event without fuel damage and the student does not recognize the wind direction is on the edge between to sectors.

Technical Reference(s): 0-EPIP-20101, Duties of
Emergency Coordinator

(Attach if not previously provided)

0-EPIP-20134, Offsite Notifications
and Protective Action
Recommendations

Proposed References to be provided to applicants during examination: F439, F444, F668,
and F669

Learning Objective: (As available)

Question Source: Bank #
Modified Bank # (Note changes or attach parent)
New X

Question History: Last NRC Exam:

Question Cognitive Level: Memory or Fundamental Knowledge
Comprehension or Analysis (3PEO)

Question Difficulty Level: B

10 CFR Part 55 Content: 55.41
55.43 5

Assessment of facility conditions and selection of appropriate procedures during normal,
abnormal, and emergency situations.

Comments:

SRO Only Justification:

This question is SRO Only because it tests ability to declare the proper EAL.

K/A Match Justification:

This question matches the K/A in that it tests Loss of Containment Integrity (Potential Loss of the Primary Containment Barrier) and its impact on an EAL Threshold (GE - based on loss of 2/3 barriers and potential loss of the 3rd).

Facility: Turkey Point
Vendor: WEC
Exam Date: 2011
Exam Type: SRO ONLY

Examination Outline Cross-reference:	Level	RO	SRO
	Tier #		1
	Group #		2
	K/A #	076	2.4.31
	Importance Rating		4.1

Emergency Procedures / Plan: Knowledge of annunciator alarms, indications, or response procedures.

Proposed Question: SRO Question # 84

Given the following plant conditions:

- Unit 3 at 100% power.
- R-3-20, Reactor Coolant Letdown Monitor is in High Alarm.
- Chemistry reported Dose Equivalent I-131 has exceeded 100 $\mu\text{Ci/gm}$.
- A Unit 3 shutdown is in progress.

Which ONE of the choices below completes the following statements?

In accordance with 3-ONOP-041.4, Excessive Reactor Coolant System Activity, the average Reactor Coolant System temperature is required to be less than (1) within 6 hours.

IF the reactor coolant activity (dose equivalent iodine) stabilizes at 320 $\mu\text{Ci/gm}$ during the shutdown, THEN the highest required emergency classification is a/an (2).

REFERENCE PROVIDED

- A. (1) 350°F
(2) Alert
- B. (1) 500°F
(2) Alert
- C. (1) 350°F
(2) Notification Of Unusual Event
- D. (1) 500°F
(2) Notification Of Unusual Event

Proposed Answer: B

Explanation (Optional):

- A. Incorrect since the required temperature is < 500°F, not 350°F. Plausible because the 2nd part is correct.
- B. CORRECT.

Per 3-ONOP-041.4, Section 5.4 (Page 5):

Be in at least Hot Standby with average reactor coolant temperature less than 500°F within 6 hours. (T.S. 3.4.8) When specific activity exceeds 1 μCi/gm Dose Equivalent I-131 for more than 48 hours during one continuous time interval. After the Reactor Coolant activity rises to 300 uCi/gm. The emergency classification is Alert.

- C. Incorrect since after the Reactor Coolant activity rises above 300 uCi/gm. The emergency classification is Alert. Plausible because being in at least Hot Standby with an average reactor coolant temperature at 350°F sounds reasonable due to being a mode change temperature.
- D. Incorrect since after the Reactor Coolant activity rises above 300 uCi/gm. The emergency classification is Alert. Plausible 2nd part is correct.

0-EPIP-20101, Duties of
Emergency Coordinator

Technical Reference(s): 3-ONOP-041.4, Excessive Reactor Coolant System Activity (Attach if not previously provided)

F668 and F669

Proposed References to be provided to applicants during examination: F668 and F669

Learning Objective: LP 6902228, Obj. 6 (As available)

Question Source: Bank #
Modified Bank # (Note changes or attach parent)
New X

Question History: Last NRC Exam:

Question Cognitive Level: Memory or Fundamental Knowledge
Comprehension or Analysis (2DR)

Question Difficulty Level: B

10 CFR Part 55 Content: 55.41
55.43 2

Facility operating limitations in the technical specifications and their bases.

Comments:

K/A Match Justification:

This question matches the K/A in that it tests knowledge of a response procedure (3-ONOP-041.4) for a High RCS Activity.

Question Selection Methodology:

Deleted original question selected by the Exam Generator because it had nothing to do with RCS activity. It was a Service Water System question. Wrote a new question to replace it.

SRO Only Justification:

This question is SRO Only because it tests knowledge of bases for a TS that is not a Safety Limit. Additionally, it tests knowledge of a TS action that is greater than 1 hour.

Facility: Turkey Point
Vendor: WEC
Exam Date: 2011
Exam Type: SRO ONLY

Examination Outline Cross-reference:	Level	RO	SRO
	Tier #		1
	Group #		2
	K/A #	E03	EA2.2
	Importance Rating		4.1

Ability to determine and interpret the following as they apply to the (LOCA Cooldown and Depressurization) Adherence to appropriate procedures and operation within the limitations in the facility's license and amendments.

Proposed Question: SRO Question # 85

Following a LOCA, the crew entered 3-EOP-E-1, Loss of Reactor or Secondary Coolant.

The following plant conditions exist:

- Over the past 60 minutes, Tcold has dropped 210°F and is currently 330°F and stable.
- RCS pressure is 560 psig and stable.
- S/G pressures are 580 psig and lowering slowly.
- S/G Narrow Range levels are 40% - 45%.
- AFW flow is 300 GPM.
- Pressurizer Level is 10% and rising slowly.
- Containment temperature is 195°F.
- RWST level is 195,000 gallons and lowering.
- HHSI Flow is 750 gpm.
- RHR Flow is 0 gpm.

Based on the above conditions, which ONE of the following is the required procedure at this time?

- A. 3-EOP-ES-1.1, SI Termination
- B. 3-EOP-ES-1.2, Post LOCA Cooldown and Depressurization
- C. 3-EOP-ES-1.3, Transfer To Cold Leg Recirculation
- D. 3-EOP-FR-P.1, Response to Imminent Pressurized Thermal Shock Condition

Proposed Answer: B

Explanation (Optional):

- A. Incorrect procedure transition based on above conditions. Plausible because SI Termination is a transition from 3-EOP-E-1.
- B. Correct. IAW 3-EOP-E-1, Step 19, if RCS pressure is > 250 [650] psig, go to 3-EOP-ES-1.2.
- C. Incorrect procedure transition based on above conditions. Plausible because transition to 3-EOP-ES-1.3 will occur at 155,000 gallons in the RWST.
- D. Incorrect procedure transition based on above conditions. Plausible because the transition to 3-EOP-FR-P.1 will occur at 320°F.

Technical Reference(s): 3-EOP-E-1, Step 19 (Attach if not previously provided)
3-EOP-ES-1.2, Step 1

Proposed References to be provided to applicants during examination: None

Learning Objective: LP 6902327, Obj 6 (As available)

Question Source: Bank #
Modified Bank # WTSI 62347 (Note changes or attach parent)
New

Question History: Last NRC Exam:

Question Cognitive Level: Memory or Fundamental Knowledge
Comprehension or Analysis (2DR)

Question Difficulty: Moderate (B)

10 CFR Part 55 Content: 55.41
55.43 5

Assessment of facility conditions and selection of appropriate procedures during normal, abnormal, and emergency situations.

Comments:

From Turkey Point 2005 NRC Exam. Stem Modification and Major changes to Distracters A, C, and D

Facility: Turkey Point
Vendor: WEC
Exam Date: 2011
Exam Type: SRO ONLY

Examination Outline Cross-reference:	Level	RO	SRO
	Tier #		2
	Group #		1
	K/A #	003	A2.03
	Importance Rating		3.1

Ability to (a) predict the impacts of the following malfunctions or operations on the RCPS; and (b) based on those predictions, use procedures to correct, control, or mitigate the consequences of those malfunctions or operations: Problems associated with RCP motors, including faulty motors and current, and winding and bearing temperature problems

Proposed Question: SRO Question # 86

The following conditions exist:

- Unit 4 is operating at 100% power.
- RCP A/B/C PUMP/MOTOR HI TEMP (H 9/6) is lit.
- RCP A MOTOR BEARING HI TEMP (H 9/1) is lit.
- 4A RCP Motor Bearing temperature is 187°F and rising at 5°F/minute.
- 4A RCP Motor Stator temperature is 223°F and rising at 5°F/minute.

Which ONE of the following completes the statements below?

The parameter that will first reach its RCP Trip Criteria value listed in 4-ONOP-041.1, Reactor Coolant Pump Off-Normal, is (1).

After the reactor is manually tripped, the NRC Operations Center is required to be notified within (2), in accordance with 0-ADM-115, Notification of Plant Events.

- A. (1) Motor Bearing temperature
(2) 1 hour
- B. (1) Motor Stator temperature
(2) 1 hour
- C. (1) Motor Stator temperature

(2) 4 hours

- D. (1) Motor Bearing temperature
(2) 4 hours

Proposed Answer: D

Explanation (Optional):

- A. Incorrect. Plausible because it is the correct parameter. However, the time is incorrect for notification. 1 hour is plausible since it is the time associated with emergency notification per 0-ADM-115.
- B. Incorrect. Incorrect parameter. The calculated time is close, but RCP Motor Bearing temperature will be exceeded first. However, the time is incorrect for notification. 1 hour is plausible since it is the time associated with emergency notification per 0-ADM-115.
- C. Incorrect. Incorrect parameter. The calculated time is close, but RCP Motor Bearing temperature will be exceeded first. However, the time is correct for notification. 4 hours is the required NRC notification time for an unplanned trip due to faulty equipment operation per 0-ADM-115.
- D. Correct.
4A RCP Motor Bearing temperature is 187°F. $(195-187)/5 = 1.6$ minutes
4A RCP Motor Stator temperature is 223°F. $(248-223)/5 = 5$ minutes

Trip the Unit 4 Reactor and 4A RCP based on RCP Motor Bearing temperature.

4 hours is the required NRC notification time for an unplanned trip due to faulty equipment operation per 0-ADM-115

Technical Reference(s): 4-ONOP-041.1 (Attach if not previously provided)
H-9/1 & 6 (4-ARP-097.CR.H)
0-ADM-115

Proposed References to be provided to applicants during examination: None

Learning Objective: 6902205 Obj 7 (As available)

Question Source: Bank #
Modified Bank # (Note changes or attach parent)
New X

Question History:

Last NRC Exam:

Question Cognitive Level: Memory or Fundamental Knowledge

Comprehension or Analysis (2DR)

Question Difficulty Level: B

10 CFR Part 55 Content: 55.41

55.43 5

Assessment of facility conditions and selection of appropriate procedures during normal, abnormal, and emergency situations.

Comments:

SRO because procedure selection must be made based upon prioritization of multiple abnormal indications

Facility: Turkey Point
Vendor: WEC
Exam Date: 2011
Exam Type: SRO ONLY

Examination Outline Cross-reference:	Level	RO	SRO
	Tier #		2
	Group #		1
	K/A #	005	2.2.40
	Importance Rating		3.4

Equipment Control: Ability to apply technical specifications for a system.
Proposed Question: SRO Question # 87

Unit 3 was operating at 100% power with the following conditions:

Time Log Entry

- 1300 3-OSP-050.2, Residual Heat Removal System Inservice Test has been started for 3A RHR Pump.
- 1330 3A RHR Pump was declared INOPERABLE due to a problem occurring during 3-OSP-050.2.
- 1357 3B RHR Pump was declared INOPERABLE due to an excessive pump seal leakage.
- 1444 Unit 3 shutdown was commenced.
- 1551 3B RHR Pump was returned to OPERABLE status after pump seal repair.
- 1604 3A RHR Pump was returned to OPERABLE status.

Which ONE of the following describes the Technical Specification requirements for operation of the plant?

REFERENCE PROVIDED

- A. The Unit 3 Shutdown may be stopped, but no earlier than 1551.
- B. The Unit 3 Shutdown may be stopped, but no earlier than 1604.
- C. Unit 3 must be in MODE 3 by 1957, MODE 4 by 0157, and MODE 5 within the subsequent 24 hours.
- D. Unit 3 must be in MODE 3 by 2044, MODE 4 by 0244, and MODE 5 within the subsequent 24 hours.

Proposed Answer: A

Explanation (Optional):

- A. Correct. With two RHR Pumps no longer inoperable, TS 3.0.3 no longer applies.
- B. Incorrect. The plant can be terminated earlier than 1604. Plausible because the applicant may require the 2nd RHR to be returned to service prior to exiting TS 3.0.3.
- C. Incorrect. Plausible since action has to be taken within 1 hour to shutdown. The applicant applies this knowledge to the transition to MODE 3, 4, 5.
- D. Incorrect. Plausible since this is the time to be in MODE 3, 4, 5 if the shutdown were to continue.

Technical Reference(s): TS 3.5.2, SR 4.5.2
TS 3.0.3

TS 3.5.2, SR 4.5.2

Proposed References to be provided to applicants during examination: ~~None~~ T.S. 3.5.2
PP 3/4 5-3 thru
3/4 5-8

Learning Objective: 6900121A, Obj 12c (As available)

Question Source: Bank #
Modified Bank # (Note changes or attach parent)
New X

Question History: Last NRC Exam:

Question Cognitive Level: Memory or Fundamental Knowledge
Comprehension or Analysis (2RI)

Question Difficulty Level: B

10 CFR Part 55 Content: 55.41
55.43 2

Facility operating limitations in the technical specifications and their bases.

Comments:

Facility: Turkey Point
Vendor: WEC
Exam Date: 2011
Exam Type: SRO ONLY

Examination Outline Cross-reference:	Level	RO	SRO
	Tier #		2
	Group #		1
	K/A #	062	2.2.22
	Importance Rating		2.1

Equipment Control: Knowledge of limiting conditions for operations and safety limits.

Proposed Question: SRO Question # 88

The following conditions exist:

- Unit 3 and 4 are at 100% power.
- Unit 3 Startup Transformer is INOPERABLE.
- Estimated time for restoration is unknown.

Which ONE of the following identifies (1) the required Technical Specification action in accordance with Technical Specification 3.8.1, AC Sources, and (2) the bases for this action in accordance with 0-ADM-536, Technical Specifications Bases Control Program?

REFERENCE PROVIDED

- A. (1) Reduce power operation to $\leq 30\%$ on Unit 3 within 48 hours, OR place the associated unit in at least HOT STANDBY within the next 12 hours.
(2) Allows for a reasonable restoration of the Startup Transformer, bounded by online risk assessment models.
- B. (1) Reduce power operation to $\leq 30\%$ on Unit 3 within 24 hours, then power operation for Unit 3 may continue for 30 days.
(2) Allows for a reasonable restoration of the Startup Transformer, bounded by online risk assessment models.
- C. (1) Reduce power operation to $\leq 30\%$ on Unit 3 within 48 hours, OR place the associated unit in at least HOT STANDBY within the next 12 hours.
(2) $< 30\%$ power operation reduces the decay heat level and allows for automatic Feedwater Control.
- D. (1) Reduce power operation $\leq 30\%$ on Unit 3 within 24 hours, then power operation for Unit 3 may continue for 30 days.
(2) $< 30\%$ power operation reduces the decay heat level and allows for automatic

Feedwater Control.

Proposed Answer: D

Explanation (Optional):

- A. Incorrect. Plausibility – Power reduction to $\leq 30\%$ is correct, but in 24 hrs not 48 hrs. However, 48 hrs is the limited time requirement prior to plant shutdown. Also, the associated unit is taken to Hot Stby in 6 hrs vice 12 hrs. 12 hrs is a value required for a dual unit shutdown to MODE 3. The basis is incorrect and something that is used in the work planning and execution process.
- B. Incorrect. Plausibility – The first part is the correct action per Tech Specs. Also, the basis is incorrect and something that is used in the work planning and execution process.
- C. Incorrect. Plausibility – Power reduction to $\leq 30\%$ is correct, but in 24 hrs not 48 hrs. However, 48 hrs is the limited time requirement prior to plant shutdown. Also, the associated unit is taken to Hot Stby in 6 hrs vice 12 hrs. 12 hrs is a value required for a dual unit shutdown to MODE 3. The basis is correct < 30% power operations reduces the decay heat level and allows for automatic Feedwater Control.
- D. Correct.

Technical Reference(s): TS 3.8.1.1, 3.8.1.2 (Attach if not previously provided)

Proposed References to be provided to applicants during examination: TS 3.8.1.1

Learning Objective: 6902136 Obj 15 (As available)

Question Source: Bank #
Modified Bank # (Note changes or attach parent)
New X

Question History: Last NRC Exam:

Question Cognitive Level: Memory or Fundamental Knowledge
Comprehension or Analysis (2DR)

Question Difficulty Level: B

10 CFR Part 55 Content: 55.41

55.43 2

Facility operating limitations in the technical specifications and their bases.

Comments:

Facility: Turkey Point
Vendor: WEC
Exam Date: 2011
Exam Type: SRO ONLY

Examination Outline Cross-reference:	Level	RO	SRO
	Tier #		2
	Group #		1
	K/A #	073	A2.02
	Importance Rating		3.2

Ability to (a) predict the impacts of the following malfunctions or operations on the PRM system; and (b) based on those predictions, use procedures to correct, control, or mitigate the consequences of those malfunctions or operations: Detector failure

Proposed Question: SRO Question # 89

The following conditions exist:

- A Waste Gas Decay Tank (WGT) E release was in progress.
- R-14, Plant Vent Gaseous Monitor, FAIL indicator light illuminates with indication pegged low.
- Initial sample results for release of the tank were acceptable in accordance with 0-NCOP-004, Preparation of Gas Release Permits.

Which ONE of the following identifies (1) if RCV-14 will automatically close and (2) in accordance with the Offsite Dose Calculation Manual (ODCM), the MINIMUM required actions to recommence the release with this failure?

- A. (1) Release will automatically terminate.
(2) The WGT E release may be recommenced ONLY after Chemistry performs ONE additional sample and ONE additional calculation.
- B. (1) Release will automatically terminate.
(2) The WGT E release may be recommenced ONLY after Chemistry performs TWO independent samples and TWO independent calculations.
- C. (1) Release will NOT automatically terminate.
(2) After the release has been locally terminated, the WGT E release may be recommenced ONLY after Chemistry performs ONE additional sample and ONE additional calculation.
- D. (1) Release will NOT automatically terminate.
(2) After the release has been locally terminated, the WGT E release may be recommenced ONLY after Chemistry performs TWO independent samples and TWO independent calculations.

Proposed Answer: D

Explanation (Optional):

- A. Incorrect due to the release will not automatically terminate if the rad monitor fails low. Plausible because the release will terminate automatically if the rad monitor fails high. One independent sample is plausible if the student assumes the first independent sample to start the discharge counts towards the 2 required to recommence the discharge.
- B. Incorrect due to the release will not automatically terminate if the rad monitor fails low. Plausible because the release will terminate automatically if the rad monitor fails high. Also plausible because 2nd part is correct.
- C. Incorrect - One independent sample is plausible if the student assumes the first independent sample to start the discharge counts towards the 2 required to recommence the discharge. Also plausible because 1st part is correct.
- D. Correct.

Technical Reference(s): ODCM Table 3.1-1 (Attach if not previously provided)
3-ONOP-067

Proposed References to be provided to applicants during examination: None

Learning Objective: 6900150 EO12 (As available)

Question Source: Bank #
Modified Bank # WTSI 71329 (Note changes or attach parent)
New

Question History: Last NRC Exam:

Question Cognitive Level: Memory or Fundamental Knowledge
Comprehension or Analysis (2RI)

Question Difficulty Level: B

10 CFR Part 55 Content: 55.41

Radiation hazards that may arise during normal and abnormal situations, including maintenance activities and various contamination conditions.

Comments:

Reworded question and changed correct answer.

This item is SRO level because it meets the requirements of 10CFR55.43(b) 4 as shown below:

D. Radiation hazards that may arise during normal and abnormal situations, including maintenance activities and various contamination conditions.

[10 CFR 55.43(b)(4)]

Some examples of SRO exam items for this topic include:

- Process for gaseous/liquid release approvals, i.e., release permits.
- Analysis and interpretation of radiation and activity readings as they pertain to selection of administrative, normal, abnormal, and emergency procedures.

Analysis and interpretation of coolant activity, including comparison to emergency plan criteria and/or regulatory limits.

SRO-only knowledge should not be claimed for questions that can be answered *solely* based on RO knowledge of radiological safety principles; e.g., RWP requirements, stay-time, DAC-hours, etc.

Modified from 2010-2 PTN exam

Facility: Turkey Point
Vendor: WEC
Exam Date: 2011
Exam Type: SRO ONLY

Examination Outline Cross-reference:	Level	RO	SRO
	Tier #		2
	Group #		1
	K/A #	076	A2.01
	Importance Rating		3.7

Ability to (a) predict the impacts of the following malfunctions or operations on the SWS; and (b) based on those predictions, use procedures to correct, control, or mitigate the consequences of those malfunctions or operations: Loss of SWS

Proposed Question: SRO Question # 90

The following conditions exist:

- Unit 3 is at 100%.
- Traveling Screen D/P is 8.0" H₂O.
- ICW/CCW and ICW/TPCW Basket Strainers are clogging due to grass influx.
- 3C ICW Pump out of service.
- 3A, 3B, and 3C CCW Heat Exchangers have ICW flows at 3000 gpm each.
- CCW Heat Exchanger Outlet temperature (shell side) is 104°F and stable.

Which ONE of the following identifies the MINIMUM required ACTIONS of TS 3.7.3, Intake Cooling Water System?

REFERENCE PROVIDED

- A. TS 3.7.3 ACTION A ONLY
- B. TS 3.7.3 ACTION C ONLY
- C. TS 3.7.3 ACTIONS A and C ONLY
- D. TS LCO 3.0.3 and TS 3.7.3 ACTIONS A and C

Proposed Answer: D

Explanation (Optional):

- A. Incorrect because with low system flow additional action statements are required. Plausible because student may miss flow required action statements and one ICW pump is out of service.
- B. Incorrect because all headers are OOS due to low flow. Plausible because student may miss flow required action statements and one ICW pump is out of service.
- C. Incorrect. Headers are not inoperable at this time. Shutdown is related to TS 3.0.3 for inoperable headers
- D. Correct.

Technical Reference(s): 3-ONOP-019 (Attach if not previously provided)
3-ARP-097.E E2/2
TS 3.7.3

Proposed References to be provided to applicants during examination:

None T.S. 3.7.3
PP 3/47-14

Learning Objective: 6902277 Obj 7 (As available)

Question Source: Bank #
Modified Bank # X (Note changes or attach parent)
New

Question History: Last NRC Exam:

Question Cognitive Level: Memory or Fundamental Knowledge
Comprehension or Analysis (3SPK)

Question Difficulty Level: B

10 CFR Part 55 Content: 55.41
55.43 5

Assessment of facility conditions and selection of appropriate procedures during normal, abnormal, and emergency situations.

Comments:

Mod from ILC 25 #53

Facility: Turkey Point
Vendor: WEC
Exam Date: 2011
Exam Type: SRO ONLY

Examination Outline Cross-reference:	Level	RO	SRO
	Tier #		2
	Group #		2
	K/A #	014	A2.02
	Importance Rating		3.6

Ability to (a) predict the impacts of the following malfunctions or operations on the RPIS; and (b) based on those on those predictions, use procedures to correct, control, or mitigate the consequences of those malfunctions or operations: Loss of power to the RPIS

Proposed Question: SRO Question # 91

The following conditions exist:

- Unit 3 is operating at 100% power.
- Annunciator F-4/6, RPIS POWER TROUBLE is lit.
- Unit 3 Turbine Operator reports the RPI Inverter Output Breaker, 3Y03-CB6, is open.

Which ONE of the following (1) identifies which Control Rod Position Analog/Group Demand Position indication that is lost, and (2) determines the required Technical Specification ACTION?

- A. (1) Analog Rod Position Indications
(2) Determine the position of the non-indicating rod(s) indirectly by the movable incore detectors at least once per 8 hours.
- B. (1) Group Step Counter Demanded Position Indicators
(2) Verify that all analog rod position indicators for the affected bank are OPERABLE and that the most withdrawn rod and the least withdrawn rod of the bank are within the Allowed Rod Misalignment of Specification 3.1.3.1 at least once per 8 hours.
- C. (1) Analog Rod Position Indications
(2) Reenergize the RPIS Loads within 1 hour OR be in at least HOT STANDBY in next

6 hours

- D. (1) Group Step Counter Demanded Position Indicators
- (2) Reenergize the RPIS Loads within 1 hour OR be in at least HOT STANDBY in next 6 hours

Proposed Answer: C

Explanation (Optional):

- A. Incorrect. Plausible because ALL Analog Rod Position Indications are extinguished is a correct statement. Also, the second part is plausible because it is an action required for different circumstance
- B. Incorrect since the Group Step Counter Demanded Position Indicators maintain power. Plausible because it is logical with Annunciator RPIS POWER TROUBLE to assume they have lost power. Also, the second part is plausible because it is an action required for different circumstance
- C. Correct. ALL Analog Rod Position Indications are extinguished. The unit is in a 3.0.3 condition.
- D. Incorrect since the Group Step Counter Demanded Position Indicators maintain power. Plausible because it is logical with Annunciator RPIS POWER TROUBLE to assume they have lost power. Also, the second part is plausible because it is correct.

Technical Reference(s): TS 3.1.3.2, TS LCO 3.0.3 (Attach if not previously provided)
3-ARP-097.CR.F, F-4/9
3-NOP-028.01

Proposed References to be provided to applicants during examination: None

Learning Objective: 6900106, Obj 8c (As available)

Question Source: Bank #
Modified Bank # (Note changes or attach parent)
New X

Question History: Last NRC Exam:

Question Cognitive Level: Memory or Fundamental Knowledge
Comprehension or Analysis (2DR)

Question Difficulty Level: B

10 CFR Part 55 Content: 55.41
55.43 2

Facility operating limitations in the technical specifications and their bases.

Comments:

Facility: Turkey Point
Vendor: WEC
Exam Date: 2011
Exam Type: SRO ONLY

Examination Outline Cross-reference:	Level	RO	SRO
	Tier #		2
	Group #		2
	K/A #	068	A2.04
	Importance Rating		3.3

Ability to (a) predict the impacts of the following malfunctions or operations on the Liquid Radwaste System ; and (b) based on those predictions, use procedures to correct, control, or mitigate the consequences of those malfunctions or operations: Failure of automatic isolation

Proposed Question: SRO Question # 92

Given the following conditions:

- A Liquid Release is in progress from Recycle Monitor Tank A to Discharge Canal using Monitor Tank Pump A.
- Annunciator WASTE LIQUID HI RADIATION (WB.B 5/3) is received.
- RCV-018, Liquid Waste Discharge Isolation Valve, fails to close either automatically or manually.
- The Shift Manager has determined an Unmonitored Release has occurred.

Which ONE of the following identifies (1) the NEXT action required in accordance with 0-NOP-061.11A, Controlled Liquid Release from Recycle Monitor Tank A, and (2) the MINIMUM required NRC notification(s) in accordance with 0-ADM-115, Notification of Plant Events?

- A. (1) Stop the Monitor Tank Pump A
(2) Notify the NRC Resident ONLY
- B. (1) Stop the Monitor Tank Pump A
(2) Notify the NRC Resident and the NRC Operations Center
- C. (1) Close 1282, Monitor Tank A Outlet Valve
(2) Notify the NRC Resident ONLY
- D. (1) Close 1282, Monitor Tank A Outlet Valve
(2) Notify the NRC Resident and the NRC Operations Center

Proposed Answer: A

Explanation (Optional):

- A. Correct
- B. Incorrect. Plausible because first part is correct. Also plausible because student may mistake a failure of the isolation valve to be classified as an unusual or abnormal release of radioactive effluents in accordance with Enclosure 1 of O-ADM-115.
- C. Incorrect since the NEXT step is to stop the Monitor Tank Pump, not close tank outlet. Plausible because second part is correct and closing the valve may stop the discharge, but could damage the pump. Also plausible because the 2nd part is correct.
- D. Incorrect since the NEXT step is to stop the Monitor Tank Pump, not close tank outlet. Plausible because second part is correct and closing the valve may stop the discharge, but could damage the pump. Also plausible because student may mistake a failure of the isolation valve to be classified as an unusual or abnormal release of radioactive effluents in accordance with Enclosure 1 of O-ADM-115.

Technical Reference(s): 0-NOP-061.11A, Controlled Liquid Release from Recycle Monitor Tank A (Attach if not previously provided)

Proposed References to be provided to applicants during examination: None

Learning Objective: LP 6902242, Obj. 7 (As available)

Question Source: Bank #
Modified Bank # (Note changes or attach parent)
New X

Question History: Last NRC Exam:

Question Cognitive Level: Memory or Fundamental Knowledge (1P)
Comprehension or Analysis

Question Difficulty Level: B

10 CFR Part 55 Content: 55.41
55.43 4

Radiation hazards that may arise during normal and abnormal situations, including maintenance

activities and various contamination conditions.

Comments:

This item meets requirements of 10CFR55.43(b) 4 based upon the criteria below:

D. Radiation hazards that may arise during normal and abnormal situations, including maintenance activities and various contamination conditions.

[10 CFR 55.43(b)(4)]

Some examples of SRO exam items for this topic include:

- Process for gaseous/liquid release approvals, i.e., release permits.
- Analysis and interpretation of radiation and activity readings as they pertain to selection of administrative, normal, abnormal, and emergency procedures.

Analysis and interpretation of coolant activity, including comparison to emergency plan criteria and/or regulatory limits.

SRO-only knowledge should not be claimed for questions that can be answered *solely* based on RO knowledge of radiological safety principles; e.g., RWP requirements, stay-time, DAC-hours, etc.

Facility: Turkey Point
Vendor: WEC
Exam Date: 2011
Exam Type: SRO ONLY

Examination Outline Cross-reference:	Level	RO	SRO
	Tier #		2
	Group #		2
	K/A #	017	2.4.3
	Importance Rating		3.9

Emergency Procedures / Plan: Ability to identify post-accident instrumentation.

017 – Incore Temperature Monitoring System

Proposed Question: SRO Question # 93

Unit 3 is in MODE 3 during a reactor startup.

- Core Exit Thermocouples from B QSPDS Train are out of service.
- The Train A QSPDS readings are provided on the DCS printout from QSPDS CET/HJTC Channel A display.

Which ONE of the following describes (1) the ACTION(s) required for Core Exit TCs in accordance with TS 3.3.3.3, Accident Monitoring Instrumentation, and (2) the impact to the reactor startup?

REFERENCES PROVIDED

- A. (1) Action Statement 31.
(2) The startup may NOT continue.
- B. (1) Action Statement 32.
(2) The startup may NOT continue.
- C. (1) Action Statement 32.
(2) The startup may continue.
- D. (1) Action Statement 31
(2) The startup may continue.

Proposed Answer: D

Explanation (Optional):

- A. Incorrect. Plausible because this is the correct Action Statement. On Part 2, the student believes a Mode change cannot be made while in an Action Statement which is a true fact if SR 3.04 is not applicable.
- B. Incorrect. Plausible because this Action Statement applies to out of service CETs. However, this is an incorrect Action Statement. On Part 2, the student believes a Mode change cannot be made while in an Action Statement which is a true fact if SR 3.04 is not applicable.
- C. Incorrect. Plausible because this Action Statement applies to out of service CETs. However, this is an incorrect Action Statement. On Part 2, the student believes a Mode change cannot be made while in an Action Statement which is a true fact if SR 3.04 is not applicable.
- D. Correct.

Technical Reference(s): TS 3.3.3.3 amendments 227/223 (Attach if not previously provided)

Proposed References to be provided to applicants during examination:

TS 3.3.3.3
QSPDS DCS Printout

Learning Objective: 6902103 Obj 10a

(As available)

Question Source: Bank #

Modified Bank #

(Note changes or attach parent)

New

X

Question History:

Last NRC Exam:

Question Cognitive Level: Memory or Fundamental Knowledge

Comprehension or Analysis

(2RI)

Question Difficulty Level: B

10 CFR Part 55 Content: 55.41

55.43 2

Facility operating limitations in the technical specifications and their bases.

Comments:

SRO because TS action on Mode change is 'below the line' knowledge exclusive to SRO

Facility: Turkey Point
Vendor: WEC
Exam Date: 2011
Exam Type: SRO ONLY

Examination Outline Cross-reference:	Level	RO	SRO
	Tier #		3
	Group #		1
	K/A #	G1	2.1.36
	Importance Rating		4.1

Conduct of Operations: Knowledge of procedures and limitations involved in core alterations.
Proposed Question: SRO Question # 94

Given the following:

<u>Date</u>	<u>Time</u>	<u>Activity</u>
12/31/2011	0000	A Unit 4 Shutdown to MODE 3 is commenced.
12/31/2011	0630	Unit 4 enters MODE 3.
12/31/2011	1320	Unit 4 enters MODE 4.
12/31/2011	2210	Unit 4 enters MODE 5.
01/01/2012	2200	The first Reactor Vessel Head Stud is detensioned.
01/03/2012	0100	The Reactor Vessel Head is removed.

Which ONE of the following is (1) the EARLIEST time to commence fuel movement in accordance with Technical Specifications, and (2) the basis for the time requirement?

- A. (1) 01/03/12 at 0630
(2) Ensures the heat load assumptions specified in the safety analysis are met to prevent boiling in the Spent Fuel Pool.
- B. (1) 01/03/12 at 0630
(2) Ensures that the release of fission product radioactivity, subsequent to a fuel handling accident, results in doses that are well within the values specified in the safety analysis.

- C. (1) 01/04/12 at 2200
(2) Ensures the heat load assumptions specified in the safety analysis are met to prevent boiling in the Spent Fuel Pool.
- D. (1) 01/04/12 at 2200
(2) Ensures that the release of fission product radioactivity, subsequent to a fuel handling accident, results in doses that are well within the values specified in the safety analysis.

Proposed Answer: B

Explanation (Optional):

- A. Incorrect. Plausible because the time is correct and because the basis is incorrect but heat load in the SFP is a concern for time to boil.
- B. CORRECT. See TS 3.9.3 and ADM-536, page 106 of 112
- C. Incorrect. Plausible because the time is 72 hours from Mode 6 entry and because the basis is incorrect but heat load in the SFP is a concern for time to boil.
- D. Incorrect. Plausible because the time is 72 hours from Mode 6 entry and because the basis is correct

Technical Reference(s): TS 3.9.3 (Attach if not previously provided)
ADM-536

Proposed References to be provided to applicants during examination: None

Learning Objective: (As available)

Question Source: Bank #
Modified Bank # (Note changes or attach parent)
New X

Question History: Last NRC Exam:

Question Cognitive Level: Memory or Fundamental Knowledge

Comprehension or Analysis (1F)
Question Difficulty Level: B
10 CFR Part 55 Content: 55.41
55.43 7

Comments:

Facility: Turkey Point
 Vendor: WEC
 Exam Date: 2011
 Exam Type: SRO ONLY

Examination Outline Cross-reference:	Level	RO	SRO
	Tier #		3
	Group #		2
	K/A #	G2	2.2.35
	Importance Rating		4.5

Equipment Control: Ability to determine Technical Specification Mode of Operation.

Proposed Question: SRO Question # 95

A plant cooldown is in progress on Unit 3:

- RCS temperature is 260°F.
- RCS pressure is 350 psig.
- OMS was placed in service at 0900 at 275°F.
- At 1000, the crew discovered 3-OSP-041.4, Overpressure Mitigating System Nitrogen Backup Leak and Functional Test, was NOT completed for both PORVs.

Which ONE of the following describes the current MODE and the LASTEST time the OMS Surveillance is required to be completed?

REFERENCE PROVIDED

- | | <u>Unit 3 Status</u> | <u>3-OSP-041.4 must be complete by</u> |
|----|----------------------|--|
| A. | MODE 3 | 0900, tomorrow |
| B. | MODE 3 | 2100, today |
| C. | MODE 4 | 2100, today |
| D. | MODE 4 | 0900, tomorrow |

Proposed Answer: C

Explanation (Optional):

- A. Incorrect. Plausible because the unit passes through Mode 3 during a cooldown for refueling. Plausible because most missed TS surveillances allow 24 hours grace.
- B. Incorrect. Plausible because the unit passes through Mode 3 during a cooldown for refueling. Also the 2nd part is correct.
- C. Correct. See TS 3.4.9.3 and 0-ADM-536 Technical Specification Bases.
- D. Incorrect. Plausible because the MODE is correct. Also plausible because most missed TS surveillances allow 24 hours grace.

Technical Reference(s): TS 3.4.9.3 (Attach if not previously provided)
TS Definitions
3-GOP-305

Proposed References to be provided to applicants during examination: TS 3.4.9.3

Learning Objective: 6900121B Obj 8 (As available)

Question Source: Bank #
Modified Bank # (Note changes or attach parent)
New X

Question History: Last NRC Exam:

Question Cognitive Level: Memory or Fundamental Knowledge
Comprehension or Analysis (1F)

Question Difficulty Level: B

10 CFR Part 55 Content: 55.41
55.43 2

Facility operating limitations in the technical specifications and their bases.

Comments:

Facility: Turkey Point
Vendor: WEC
Exam Date: 2011
Exam Type: SRO ONLY

Examination Outline Cross-reference:	Level	RO	SRO
	Tier #		3
	Group #		2
	K/A #	G2	2.2.7
	Importance Rating		3.6

Equipment Control: Knowledge of the process for conducting special or infrequent tests.

Proposed Question: SRO Question # 96

0-OSP-040.16, Initial Criticality After Refueling and Nuclear Design Verification is being performed on Unit 3.

Which ONE of the following completes the statements below in accordance with 0-ADM-217, Conduct of Infrequently Performed Tests or Evolutions?

The Management Designee role (1).

The Management Designee role (2) to be simultaneously filled by the Unit 3 - Unit Supervisor.

- A. (1) is ONLY allowed to be Shift Managers OR Unit Supervisors
(2) is allowed
- B. (1) is ONLY allowed to be Shift Managers OR Unit Supervisors
(2) is NOT allowed
- C. (1) can be any individual designated by the Plant General Manager
(2) is allowed

- D. (1) can be any individual designated by the Plant General Manager
(2) is NOT allowed

Proposed Answer: D

Explanation (Optional):

- A. Incorrect. Both parts incorrect but plausible because it is logical that the SM would be the only management designee, and there are conditions (Unit startup/shutdown) where the on shift managers may be the management designee
- B. Incorrect. First part incorrect but logical as in A. Second part is correct
- C. Incorrect. First part is correct. Second part incorrect but plausible because other IPTEs allow the on shift crew to be management designee
- D. Correct. See 0-ADM-217

Technical Reference(s): 0-ADM-217 (Attach if not previously provided)

Proposed References to be provided to applicants during examination: None

Learning Objective: 6902045 Obj 2 (As available)

Question Source: Bank #
Modified Bank # (Note changes or attach parent)
New X

Question History: Last NRC Exam:

Question Cognitive Level: Memory or Fundamental Knowledge (1P)
Comprehension or Analysis

Question Difficulty Level: B

10 CFR Part 55 Content: 55.41
55.43 5

Assessment of facility conditions and selection of appropriate procedures during normal, abnormal, and emergency situations.

Comments:

Facility: Turkey Point
Vendor: WEC
Exam Date: 2011
Exam Type: SRO ONLY

Examination Outline Cross-reference:	Level	RO	SRO
	Tier #		3
	Group #		3
	K/A #	G3	2.3.5
	Importance Rating		2.9

Radiation Control: Ability to use radiation monitoring systems, such as fixed radiation monitors and alarms, portable survey instruments, personnel monitoring equipment, etc.

Proposed Question: SRO Question # 97

A Unit 3 Containment Purge is scheduled for this shift while in MODE 1.

Which ONE of the following identifies (1) the MINIMUM requirement for radiation monitor operability, and (2) the LOWEST required authorization to initiate a Containment Purge in accordance with 3-NOP-053, Containment Purge System?

Note:

R-3-11 (Particulate) and R-3-12 (Gaseous) Containment Radiation Monitors

R-3-14 (Plant Vent) and RAD-6304 (Plant Vent SPING) Radiation Monitors

- A. (1) R-3-11, R-3-12, R-3-14, and RAD-6304
(2) Plant General Manager
- B. (1) R-3-11 or R-3-12 and R-3-14 or RAD-6304
(2) Plant General Manager
- C. (1) R-3-11, R-3-12, R-3-14, and RAD-6304
(2) Shift Manager
- D. (1) R-3-11 or R-3-12 and R-3-14 or RAD-6304
(2) Shift Manager

Proposed Answer: B

Explanation (Optional):

- A. Incorrect. Plausibility – Only one of each radiation monitor is required, not both. Each of the radiation monitors listed provides required monitoring if it was in service as the operable monitor. Also, if these monitors were OOS. There would be compensatory actions. Also, 2nd part is correct.
- B. Correct. Only one of each radiation monitor is correct. The PGM is required for approval for MODE 1, 2, & 3 releases.
- C. Incorrect. Plausibility – Only one of each radiation monitor is required, not both. Each of the radiation monitors listed provides required monitoring if it was in service as the operable monitor. Also, the SM is required for approval for MODE 4-6 releases.
- D. Incorrect. Plausibility – 1st part of the question is correct. Also, the SM is required for approval for MODE 4-6 releases.

Technical Reference(s): 3-NOP-053 R2 (Attach if not previously provided)

Proposed References to be provided to applicants during examination: None

Learning Objective: 6902129 Obj 10c (As available)

Question Source: Bank #
 Modified Bank # (Note changes or attach parent)
 New X

Question History: Last NRC Exam:

Question Cognitive Level: Memory or Fundamental Knowledge (1P)
 Comprehension or Analysis

Question Difficulty Level: B

10 CFR Part 55 Content: 55.41
 55.43 4

Radiation hazards that may arise during normal and abnormal situations, including maintenance activities and various contamination conditions.

Comments:

Radiation hazards that may arise during normal and abnormal situations, including maintenance activities and various contamination conditions.

[10 CFR 55.43(b)(4)]

Some examples of SRO exam items for this topic include:

- Process for gaseous/liquid release approvals, i.e., release permits.
- Analysis and interpretation of radiation and activity readings as they pertain to selection of administrative, normal, abnormal, and emergency procedures.

Analysis and interpretation of coolant activity, including comparison to emergency plan criteria and/or regulatory limits.

SRO-only knowledge should not be claimed for questions that can be answered *solely* based on RO knowledge of radiological safety principles; e.g., RWP requirements, stay-time, DAC-hours, etc.

Facility: Turkey Point
Vendor: WEC
Exam Date: 2011
Exam Type: SRO ONLY

Examination Outline Cross-reference:	Level	RO	SRO
	Tier #		3
	Group #		3
	K/A #	G3	2.3.4
	Importance Rating		3.7

Radiation Control: Knowledge of radiation exposure limits under normal or emergency conditions.
Proposed Question: SRO Question # 98

Which ONE of the following completes both statements in accordance with 0-EPIP-20111,
Re-entry?

The _____ is responsible for authorizing emergency exposures that exceed 10CFR20 limits.

The emergency exposure limit for performance of actions that mitigate the escalation of the event, rescue persons from a non-life threatening situation, minimize personnel exposure or minimize effluent releases is _____.

- A. (1) Emergency Coordinator (EC)
(2) 5 REM
- B. (1) OSC Rad Protection Supervisor
(2) 5 REM
- C. (1) Emergency Coordinator (EC)
(2) 10 REM
- D. (1) OSC Rad Protection Supervisor
(2) 10 REM

Proposed Answer: C

Explanation (Optional):

- A. Incorrect. The EC is the correct position for authorization. TEDE limit is 5 Rem. Emergency exposures are 10 Rem

- B. Incorrect. The OSC Rad Protection Supervisor is the incorrect position for authorization. However, they will give radiological briefings, will issue emergency dosimetry with maximum exposure capabilities, will ensure the Nuclear Division Medical Review Officer notification, and will sign emergency exposure authorization form. Emergency exposures are 10 Rem Not 25 Rem.
- C. Correct
- D. Incorrect. The OSC Health Physics Supervisor is the incorrect position for authorization. However, they will give radiological briefings, will issue emergency dosimetry with maximum exposure capabilities, will ensure the Nuclear Division Medical Review Officer notification, and will sign emergency exposure authorization form. Also, this is plausible because the second part is true

Technical Reference(s): 0-EPIP-20111 Steps including Enclosure 1 (Attach if not previously provided)

Proposed References to be provided to applicants during examination: None

Learning Objective: 3200001 Obj. 10 (As available)

Question Source: Bank #
 Modified Bank # WTSI 66661 (Note changes or attach parent)
 New

Question History: Last NRC Exam:

Question Cognitive Level: Memory or Fundamental Knowledge (1F)
 Comprehension or Analysis

Question Difficulty: Moderate (C)

10 CFR Part 55 Content: 55.41
 55.43 4

Radiation hazards that may arise during normal and abnormal situations, including maintenance activities and various contamination conditions.

Comments:

Modified from Turkey Point 2009 NRC Exam. Changed dose rates to change correct answer.

SRO only because a decision must be made to minimize radiation exposure with an injured person in a high radiation area. This decision would be made by the SRO acting as the E-Plan Emergency Coordinator

Radiation hazards that may arise during normal and abnormal situations, including maintenance activities and various contamination conditions.

[10 CFR 55.43(b)(4)]

Some examples of SRO exam items for this topic include:

- Process for gaseous/liquid release approvals, i.e., release permits.
- Analysis and interpretation of radiation and activity readings as they pertain to selection of administrative, normal, abnormal, and emergency procedures.

Analysis and interpretation of coolant activity, including comparison to emergency plan criteria and/or regulatory limits.

SRO-only knowledge should not be claimed for questions that can be answered *solely* based on RO knowledge of radiological safety principles; e.g., RWP requirements, stay-time, DAC-hours, etc.

Facility: Turkey Point
Vendor: WEC
Exam Date: 2011
Exam Type: SRO ONLY

Examination Outline Cross-reference:	Level	RO	SRO
	Tier #		3
	Group #		4
	K/A #	G4	2.4.29
	Importance Rating		4.4

Emergency Procedures / Plan: Knowledge of the emergency plan.

Proposed Question: SRO Question # 99

Unit 4 experienced a 4C Steam Generator Tube Rupture with the crew responding in accordance with 4-EOP-E-3, Steam Generator Tube Rupture.

Subsequently:

- All Unit 4 Aux Feedwater Steam Supply Valves to Aux Feedwater Pumps are open with the AFW Pumps supplying S/Gs 4A and 4B.
- 4C S/G Steam Dump to Atmosphere Valve stuck open and was manually isolated.
- The Unit 4 Turbine Operator has just been directed to reposition AFSS-3-006, STM HDR TRAIN 1 AND 2 TIE VALVE, and AFSS-3-007, S/G B TO STM HDR TRAIN 1 TIE VALVE, to provide steam from an intact S/G(s) to all AFW Pumps.
- No other actions in 4-EOP-E-3 have been taken.

Which ONE of the following identifies whether a release path currently exists and the highest required emergency classification?

A release path (1) .

The highest required emergency classification is (2) .

REFERENCE PROVIDED

- A. (1) does NOT exist
(2) Alert
- B. (1) does NOT exist
(2) Site Area Emergency
- C. (1) exists
(2) Alert

- D. (1) exists
(2) Site Area Emergency

Proposed Answer: D

Explanation (Optional):

- A. Incorrect because release is ongoing, however this is plausible after the S/G is isolated in 4-EOP-E-3. The highest emergency classification is a SAE.
- B. Incorrect because release is ongoing, however this is plausible after the S/G is isolated in 4-EOP-E-3. The highest emergency classification is a SAE.
- C. Incorrect. It is correct that the release is ongoing. However, the highest emergency classification is a SAE.
- D. Correct.

Technical Reference(s): 0-EPIP-20101 (Attach if not previously provided)
0-EPIP-20110 step 5.1.5

Proposed References to be provided to applicants during examination: F668 and F669

Learning Objective: 3200003 Obj. 4 (As available)

Question Source: Bank #
Modified Bank # (Note changes or attach parent)
New X

Question History: Last NRC Exam:

Question Cognitive Level: Memory or Fundamental Knowledge
Comprehension or Analysis (3SPK)

Question Difficulty: Moderate (B)

10 CFR Part 55 Content: 55.41
55.43 5

Assessment of facility conditions and selection of appropriate procedures during normal, abnormal, and emergency situations.

Comments: SRO because the test item evaluates SRO knowledge without any evaluation of RO knowledge items

Facility: Turkey Point
Vendor: WEC
Exam Date: 2011
Exam Type: SRO ONLY

Examination Outline Cross-reference:	Level	RO	SRO
	Tier #		3
	Group #		4
	K/A #	G4	2.4.40
	Importance Rating		4.5

Emergency Procedures / Plan: Knowledge of the SRO's responsibilities in emergency plan implementation.

Proposed Question: SRO Question # 100

Initial conditions:

At 1200, Unit 3 has declared a Site Area Emergency.

At 1215, the State Warning Point was notified.

At 1240, the NRC was notified.

At 1250, Unit 4 declares an Alert.

In accordance with 0-EPIP-20134, Offsite Notifications and Protective Action Recommendations, which ONE of the following blocks is required to be checked on the Florida State Notification Form and the latest time to notify the State Warning Point concerning Unit 4?

- A. Initial/New Classification Block
No later than 1305
- B. Initial/New Classification Block
No later than 1315
- C. Update Notification Block
No later than 1305
- D. Update Notification Block
No later than 1315

Proposed Answer: C

Explanation (Optional):

- A. Incorrect. See 0-EPIP-20101, Step 5.1.19 and 5.1.20.
- B. Incorrect. See 0-EPIP-20101, Step 5.1.19 and 5.1.20.
- C. Correct. See 0-EPIP-20101, Step 5.1.19 and 5.1.20. If a unit is in a classifiable event, then subsequent events on that or the opposite unit only require an additional notification if the event is higher than the current classification. Only 1 classification will exist on the site at any time. If the event is of a lower classification then the update shall be made "as soon as possible" iaw 0-EPIP-20134, Step 5.1.16.1.
- D. Incorrect. See 0-EPIP-20101, Step 5.1.19 and 5.1.20

Technical Reference(s): 0-EPIP-20101, rev 2 (Attach if not previously provided)

Proposed References to be provided to applicants during examination: None

Learning Objective: None Found (As available)

Question Source: Bank #
Modified Bank # (Note changes or attach parent)
New X

Question History: Last NRC Exam:

Question Cognitive Level: Memory or Fundamental Knowledge (1F)
Comprehension or Analysis

Question Difficulty Level: B

10 CFR Part 55 Content: 55.41
55.43 5

Assessment of facility conditions and selection of appropriate procedures during normal, abnormal, and emergency situations.

Comments: