

$$\frac{Tq_{output}}{Th_{stem}} = \frac{d(0.96815 \tan \alpha + \mu)}{24(0.9685 - \mu \tan \alpha)} = \text{stem factor}$$

Equation (3-17)

Where

Tq_{output} = output torque of the actuator

Th_{stem} = stem thrust

d = outside diameter of the stem minus 1/2 the pitch

$$\tan a = \frac{\text{Lead}}{\pi d}$$

μ = stem friction (coefficient of friction at the interface between the stem and the stem nut).

This equation is written for U.S. Customary units, where torque is in foot-pounds, thrust is in pounds force, and stem diameter and thread pitch and lead are in inches. The pitch is the distance from the peak of one thread to the peak of an adjacent thread (inches/thread). The lead is the distance the stem travels in one revolution of the stem nut (inches/stem revolution). As an example, if the configuration consists of two threads spiraling the stem instead of one, the lead is different from the pitch. (If only one thread spirals the stem, the pitch and the lead are the same.) The output torque consists of the torque delivered to the stem nut. The stem thrust is the thrust applied to the valve stem to move the stem and valve disc. The ratio of torque to thrust, shown in

Equation 3-17, is the stem factor. The term d represents the mean diameter of the stem in terms of the thread contact area, treated as the midpoint of the depth of the thread. The design of Acme power threads is such that the depth of a single thread is equal to half the pitch, so d is equal to the outside diameter of the stem minus 1/2 the pitch (1/4 the pitch on one side, and 1/4 the pitch on the other side; refer to Figure 3-22). The term $\tan a$ is the slope of the thread. The term 0.96815 is a constant in the Acme power thread equation, representing the cosine of half the thread angle (14.5 degrees for Acme threads). The 24 ($2 * 12$) in the numerator represents the $d/2$ calculation that provides the mean radius of the stem, combined with the conversion from inches to feet; stem measurements are in inches but torque values are in ft-lb.

The mean stem diameter, the thread pitch, and the thread lead for any stem/stem-nut configuration are constants in the power thread equation. The only variable is the coefficient of friction at the interface between the stem and the stem nut. This variable is sometimes referred to in the literature as the stem/stem-nut coefficient of friction.

The results of the NRC/INEEL test programs showed that the actual stem friction at the crucial moments in the valve closing stroke (at flow isolation and at torque switch trip) can vary significantly, depending on the load profile applied to the

valve before torque switch trip. The literature sometimes refers to this phenomenon either as load-sensitive behavior or as the rate-of-loading effect. Figure 3-23 shows the stem thrust traces from four tests of the same valve, with the same torque switch setting, but with different load histories preceding torque switch trip. In this figure, the sudden increase in stem thrust, as indicated by the vertical portion of the trace, is caused when the disc wedges in the seats. The increase in thrust after torque switch trip is caused mostly by motor and gearbox momentum. Flow isolation occurs just before the disc wedges in the seats. The margin is indicated as the difference between the thrust needed for flow isolation and the thrust delivered at torque switch trip. One expects the margin

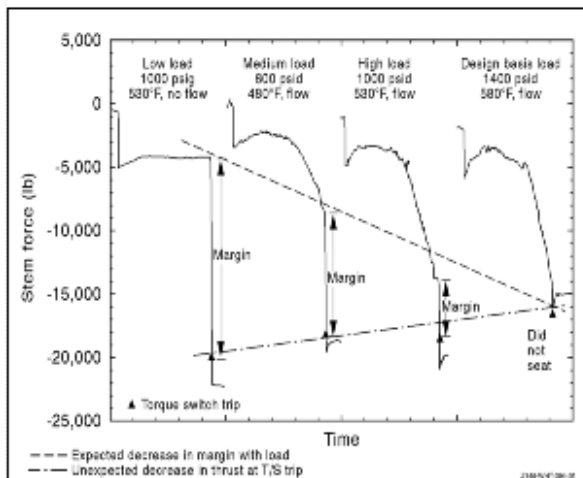

Figure 3-23 Four Stem Thrust Traces

to decrease with higher loads, as more thrust is needed for flow isolation. However, the decrease in thrust at torque switch trip at higher loads was unexpected. Since the

torque switch setting was the same in all four tests, the actuator torque at torque switch trip was presumably about the same as well. Remember, though, that the torque switch controls the torque output of the actuator, not the thrust. A decrease in thrust at a given torque indicates an increase in friction at the interface between the stem and the stem nut. Such a decrease in thrust at torque switch trip is evident in the data shown in Figure 3-23.

The data trace on the left is from a low-load test, with a stem rejection load created by the 1000 psig pressure in the valve and with a packing friction load, but with no flow load. The other three data traces are from tests with flow (and with differential pressure at flow isolation). In the low-load test, the load increases suddenly when wedging occurs, and the torque switch trips during this sudden increase in the load. This kind of load profile produces the lowest possible stem friction and the highest possible stem thrust at torque switch trip, apparently because the abundance of grease at the interface between the stem and the stem-nut allows the stem-nut threads to "float" on a layer of pressurized grease, with little or no metal to metal contact. In contrast, a load profile with a load that steadily increases, as in the other three traces, produces higher friction at torque switch trip, because more of the grease has been squeezed out of the interface by the high load before torque switch trip. Higher friction at torque switch trip corresponds

with lower stem thrust at torque switch trip. The thrust at torque switch trip in the first test shown in Figure 3-23 was 19,900 lb_f; in the fourth test, it was 16,500 lb_f.

One of the problems created by this phenomenon is the possibility that the valve analyst might perform a low-load test to obtain data for a valve evaluation, then use the stem factor, stem friction, or stem thrust data from the low-load test (data measured at torque switch trip) to estimate the actuator's capability at design basis flow and pressure conditions. This practice would produce a nonconservative estimate, since the stem friction in the design basis case is almost certain to be significantly higher than the value determined from measurements in the low-load test.

When performing an evaluation of valve operability, analysts in the U.S. typically use a stem friction value derived from plant data, that is, data from in-plant testing of many valves in that particular plant. Formerly, analysts typically used values recommended by the valve or actuator manufacturer. Recommended industry default values ranged from 0.15 to 0.20 in evaluations addressing valve operability at design basis loads. In the NRC/INEEL tests of valves and actuators, we have seen design basis stem friction values (friction near or at flow isolation in tests with loads representing significant flow and pressure) generally ranging from about 0.08 to 0.14 with freshly lubricated stems.

This is a rather broad range, but it is, in fact, bounded by the 0.15 default value formerly used in the industry. The difference between the low end of the range and the high end of the range can have a significant effect on the analyst's evaluation of valve operability.

Diagnostic tests of valves in the plants have sometimes indicated stem friction values as high as 0.20. This corresponds with the high end of the default values formerly used in the U.S. nuclear industry. Today, a valve analyst at a U.S. utility would use plant data to justify use of a stem friction value in the range of 0.15. In some cases, a higher default value of 0.20 is necessary. When performing instrumented in-plant tests to determine the actual stem friction for a valve, the analyst must take special care to ensure that the values derived from the in-plant tests are used appropriately and conservatively. To repeat: results from NRC/INEEL laboratory tests of valves and actuators show that the stem friction can vary significantly. The variability depends on:

- The particular stem and stem nut configuration. Each stem and stem nut have their own friction characteristics. Some stems show higher friction than others, and some stems show higher friction at lower loads than at higher loads, while other stems show the opposite.
- The brand of lubricant used on the stem. NRC/INEEL testing of two

- popular lubricants on eight stems showed a difference of about 0.01 to 0.02 in the stem friction. Most of the eight stems performed better (lower friction) with one lubricant than with the other; the difference was greater for some stems than for others.
- Elevated temperature and lubricant aging. As the stem/stem nut temperature changes or the grease ages, the friction is likely to change. NRC/INEEL tests investigating this issue have shown significant increases in stem nut friction at elevated temperature and age-related increases for some lubricants (NUREG/CR-6750, *Performance of MOV Stem Lubricants at Elevated Temperature* and NUREG/CR-6806, *MOV Stem Lubricant Aging Research*).
 - Load magnitude. During a closing stroke against flow and pressure, the stem friction tends to be different (either higher or lower) at the beginning of the stroke, when the load is low, than later in the stroke just before flow isolation, when the load is higher. Further, the friction tends to be lower during wedging, when the stem experiences a sudden increase in the load, than at the critical moment at or just before flow isolation, when the stem is experiencing a gradual increase in the load.

- Load profile. As shown in Figure 3-23 (discussed above), the friction at torque switch trip varies depending on the profile of the load that preceded torque switch trip. In general, a large load before flow isolation corresponds with high friction at torque switch trip, while a low load before flow isolation corresponds with low friction at torque switch trip.

This last item is of particular importance. Remember, the analyst must take care not to use a friction value determined from measurements at torque switch trip in a no-load test (no flow or pressure) as the stem friction estimate for a design basis case.

3.3.1.1 Load-Sensitive Behavior (Rate-of-Loading)

As part of the NRC/INEEL test program, we developed two methods that are helpful in efforts to use the results of low-load tests to estimate bounding values for the stem friction; the resulting estimates are conservative without being excessively so. We call the first one the threshold method. For all of the stems we tested, the stem friction data at or near flow isolation formed a plateau above a certain stem thread pressure. With the threshold method, the analyst performs a test with a low to moderate load and determines the stem friction from measurements at or near flow

isolation. The load must be high enough to produce a stem thread pressure of at least

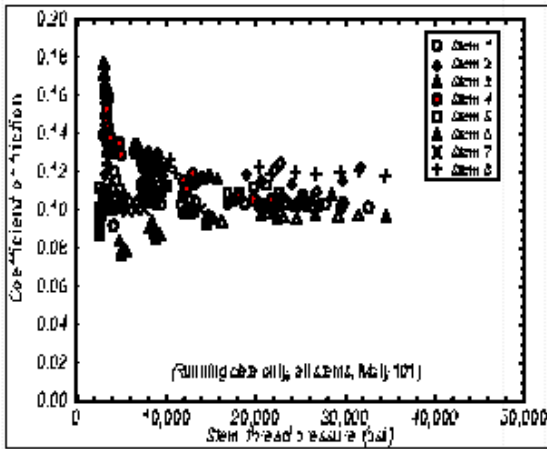

Figure 3-24 Stem Friction Before Seating

10,000 psi, as determined from a calculation of the stem thrust divided by the stem thread surface area for one thread revolution (pounds of force per square inch of thread surface area). The stem packing load plus a significant stem rejection load might be sufficient, or it might be necessary to include a flow load, such as a pump flow load. In any case, stem friction measured above the 10,000-psi thread pressure threshold provides a good indication of what the stem friction will be at flow isolation with higher loads. Figure 3-24 shows the test data upon which the threshold method is based. The data points shown on this plot represent the stem friction immediately before seating (a point representing flow isolation) in tests of eight stems at various loads. A discussion of the development of the threshold method is included in NUREG/CR-6100, *Gate Valve and Motor-Operator Research Findings*.

We call the second method the fold line method. This method is useful for valves where in-plant testing with no flow or pressure is feasible, but testing with flow combined with pressure is not. The analyst performs a no-load test and measures actuator torque and stem thrust at a frequency high enough to produce a stem friction trace for the very small moment in time during which the disc wedges in the seat. We call this trace the wedging transient. The upper plot in Figure 3-25 shows an example of such a transient, from one of the eight stems we tested, and illustrates how the highest stem friction in the wedging transient marks the friction

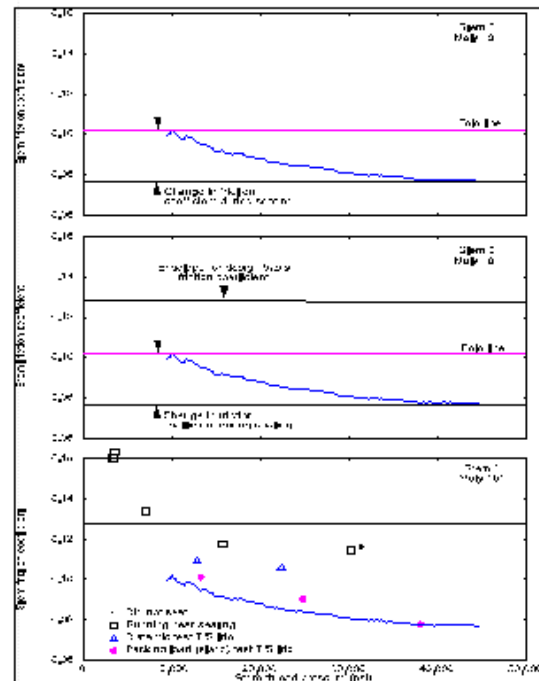

Figure 3-25 Fold Line Method of Determining Stem Friction

value that becomes the "fold line." The lowest stem friction (lower line) marks the

amount of change in the friction during the wedging transient. Quantifying this change and adding it to the value represented by the fold line produces a value (represented by the top line the middle plot in Figure 3-25) that envelopes the data and serves as a conservative estimate of the stem friction that will occur at flow isolation in the design basis case, as shown in the lower plot. A discussion of the development of the fold line method is included in NUREG/CR-6100, *Gate Valve and Motor- Operator Research Findings*.

3.3.1.2 Stem Lubrication and Friction

The effectiveness of the lubricant used on the threaded portion of the valve stem can greatly impact the thrust output of the valve actuator and reduce the margin for ensuring MOV performance at design basis. Recent testing indicates that an elevated temperature environment can lead to significant increases in the friction coefficient at the stem/stem nut interface. Lubricant aging is another phenomenon that can have a deleterious effect on the thrust output of the actuator.

Most valve actuator qualification tests incorporating actual stems, stem nuts, and lubricants are performed at room temperature. Similarly, in-service tests are run at ambient plant temperatures, usually 70 to 100°F. Since design conditions can lead to valve operating temperatures in the 200 to 300°F range, it is important to

consider whether a temperature-induced or aging related increase in friction at the stem/stem nut interface will limit the operation of critical valves.

The NRC Office of Nuclear Research sponsored a series of stem lubricant tests at the INEEL to address the effectiveness of stem/stem nut lubrication under elevated temperature conditions and after extended periods of time in service. A complete description of the testing, methods, results, and conclusions can be found in NUREG/CR-6750, *Performance of MOV Stem Lubricants at Elevated Temperature* and NUREG/CR-6806, *MOV Stem Lubricant Aging Research*. The findings of these test programs are summarized in the following paragraphs.

Elevated Temperature Performance

This research effort was performed to address the effectiveness of the lubricant used on the threaded portion of the valve stem. The effectiveness of this lubricant can greatly impact the thrust output of the valve actuator and reduce the margin for ensuring MOV performance at design basis. Our analysis looked at the performance of five lubricants on four stem and stem nut combinations. The following conclusions are based on this work.

- The physical characteristics of each lubricant change at elevated temperature. Some lubricants thicken

while others thin, allowing the lubricant to move away from loaded surfaces. Some lubricants lose their oily components.

- The repeatability of the stem friction coefficient over multiple strokes depends upon the unique stem/stem nut and lubricant combination. Large variations in stem friction can occur between strokes. Complete breakdown of the stem lubrication can occur.
- Operation at elevated temperature can have a significant effect on the stem coefficient of friction. For many of the stem, stem nut, and lubricants, large increases in stem nut friction occurred. Some lubricants showed no effect and some stem/stem nut combinations produced decreasing friction.
- The value and the direction of change in the end of stroke friction behavior (ESFB) is highly dependent on the stem/stem nut and lubricant being tested.
- Each individual stem and stem/nut combination has unique characteristics with regard to the repeatability of the stem friction coefficient over multiple strokes, the elevated temperature performance, and the ESFB.

Aged Stem Lubricant Performance

This research effort was performed to address the effectiveness of the lubricant used on the threaded portion of the valve stem. The effectiveness of this lubricant can greatly impact the thrust output of the valve actuator and reduce the margin for ensuring MOV performance at design basis. Our analysis looked at the aged performance of two lubricants on one valve stem. It also looked at a new lubricant on one stem to determine its load and end of stroke friction behavior, elevated temperature, and aging performance.

The results of this research provide an indication of how aging might affect stem and stem nut performance: however, one must keep in mind the limited sample size. The research used only one stem and stem nut combination and no repeat tests were performed. Past testing has shown that lubricants can perform quite differently on different stem and stem nut combinations. Also, stem and stem nut performance is not always repeatable with some lubricants. Additional testing with lubricants being applied to several different stem and stem nut combinations would be necessary in order to make more generic conclusions. Also, the accelerated aging applies to valves that operate in a cold environment. The data must be considered naturally aged for valves in environments near 250°F.

The following conclusions are based on this work.

- For Chevron SRI and Mobil Mobilgrease 28, lubrication aging does not appear to degrade the performance of stem and stem nut interface. For the single stem tested (Stem 2), the stem and stem nut friction did not increase during the aging period. In some cases, the final friction values for both the hot and cold tests were lower than the initial hot and cold values.
- On the single stem tested, the MOV Long Life lubricant's performance was similar or an improvement over that of other lubricants previously tested. MOV Long Life frictional performance, including end of stroke friction behavior, was stable and repeatable over a wide load range. Elevated temperature resulted in a lower friction coefficient than that observed at room temperature but resulted in greater rate-of loading. Stem nut friction appears to be stable over the simulated aging period.

3.3.2 Butterfly Valve Stem Torque

Figure 3-26 shows an overall assembly of a motor-operated butterfly valve and its principal components. It identifies the butterfly valve, a Limitorque HBC gear operator (for quarter-turn valves), and a Limitorque SMB motor actuator.

The operating torque characteristics of a butterfly valve are quite different from

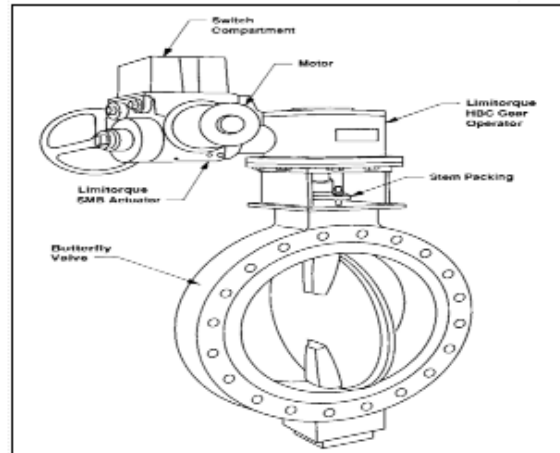

Figure 3-26 Motor Operated Butterfly Valve Assembly

those of gate and globe valves. An important consideration in determining the operating torque requirements for butterfly valves is that the maximum torque may be dictated by the seating/unseating torque or by the dynamic torque at some intermediate disc position. The magnitude of the dynamic torque is strongly dependent upon valve size, disc design, pressure drop, and mass flow through the valve.

The most common butterfly valve disc designs used in nuclear power plants are:

1. Symmetric (lens-type) disc with concentric stem (Figure 3-27a). The symmetric disc design is often called a standard disc, conventional disc, or lenticular disc. Flow and torque characteristics do not depend on flow

- direction. The valve has no preferred flow direction.
2. Nonsymmetric disc with single offset stem (Figure 3-27b). In the single offset nonsymmetric disc design, the stem centerline (and the center of disc rotation) is offset axially from the plane of the valve seat along the pipe centerline. The disc face away from the stem is flat or curved slightly and is often referred to as the flat face. The stem side of the disc is the curved face. Flow and torque characteristics depend on the flow direction with respect to the disc. Valve orientation to flow is often referred to as shaft downstream (flat face forward) or shaft upstream (curved face forward as shown in Figure 3-28).
 3. Nonsymmetric disc with double offset stem (Figure 3-27c). This design has a seat offset similar to the nonsymmetric single offset and a small lateral offset. The double offset produces a cam-like action, claimed to reduce wear and enhance sealing. In double offset designs, the resultant force due to differential pressure does not pass through the stem centerline and producing a stem torque even in the closed position.

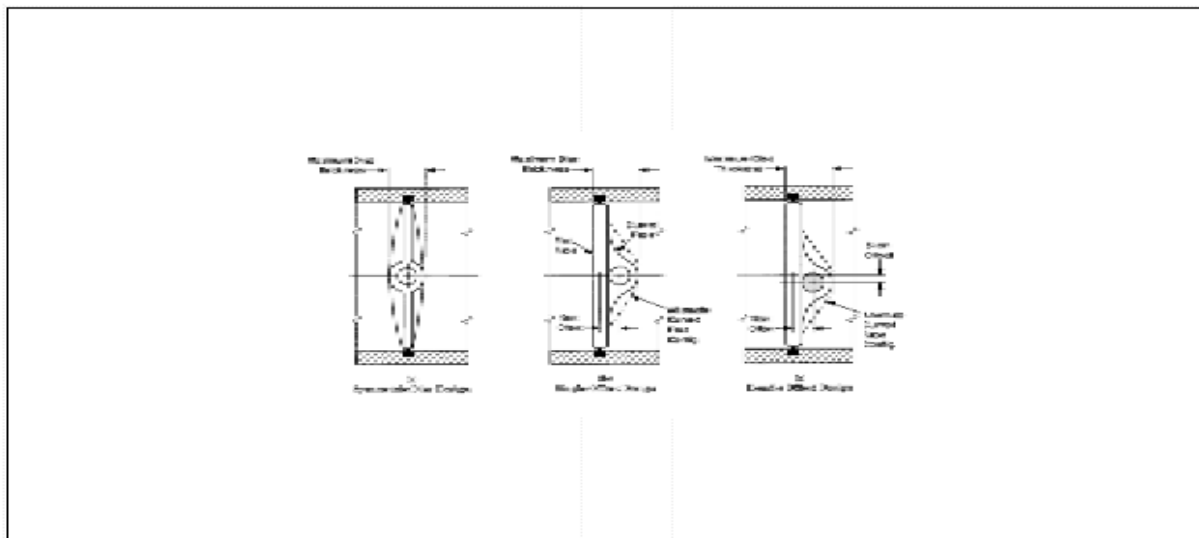

Figure 3-27 Butterfly Valve Disc Designs

Other butterfly disc designs exist, such as triple-offset discs, but are relatively uncommon in U.S. nuclear power plants. The performance characteristics of these designs are not discussed in this course.

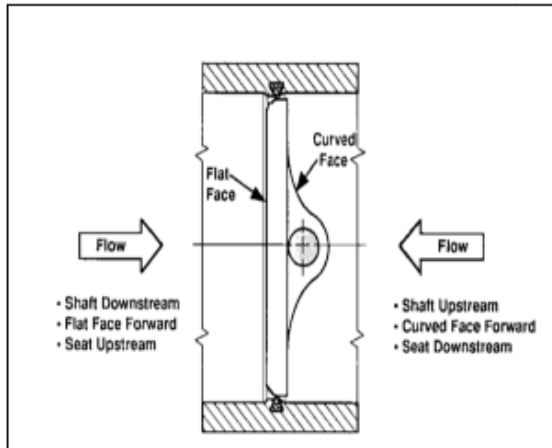

Figure 3-28 Valve Orientation to Flow

Whether the maximum torque requirements are governed by the dynamic torque or by the seating/unseating torque depends upon its size, design, and its application fluid conditions. For example, dynamic torque values for butterfly valves smaller than 20-inch operating in water at less than 16 ft/s flow [American Water Works Association (AWWA) Class “B” maximum velocity limit] are typically bounded by the seating/unseating torque values for tight shut-off seat designs. For butterfly valves in higher velocity applications, dynamic torque values can exceed the seating/unseating torque, even for small diameter valves. Therefore, the analysis of butterfly valve torque must include both the total seating/unseating torque and the total dynamic torque.

Total Seating/Unseating Torque

The total torque required to seat or unseat a butterfly valve is the sum of four components as shown in the following equation.

$$T_{TS} = T_{seat} + T_{Bearing} + T_{Packing} + T_{Hydrostatic}$$

Equation (3-18)

The seat torque (T_{Seat}) depends on the specific details of the valve seat design. The magnitude of the seat torque varies considerably due to variations in materials, design interferences, and maximum shut-off pressure requirements. Most valve manufacturers provide seat torque values and calculations for their seat designs.

Tight shut-off valves typically require a higher torque to unseat the disc than to seat the disc. For elastomeric interference type seat designs, the “break-out” torque may increase significantly after the valve has been closed for several days. The magnitude of increase depends on the seat design and lubricating qualities of the fluid, and may be as high as three times. Furthermore, seat hardening, degradation, and foreign material may increase seat torque requirements.

The bearing torque ($T_{Bearing}$) is proportional to the differential pressure across the disc. The maximum bearing torque is reached when the disc is seated and pressure drop across the valve is at its

maximum. For a known pressure drop across the valve, the bearing torque can be calculated using the valve manufacturer's bearing torque coefficients, or by using bearing geometry and the stem-to-bearing coefficient of friction.

The packing torque ($T_{Packing}$) is normally small compared to the total required torque and is often neglected in both the total seating/unseating torque and the dynamic torque calculations. The magnitude of the packing torque depends upon the stuffing box type, packing material, packing length, and gland preload. The required packing load can be determined using valve or packing manufacturers' data or calculated using packing geometry, coefficient of friction, and gland preload. Variations in packing load due to changes in valve internal pressure are very small; therefore, the packing torque is assumed to be constant over the entire valve stroke.

The hydrostatic torque ($T_{Hydrostatic}$) results from the fluid pressure acting on the valve disc to produce a torque load on the valve stem. If the valve is installed with the stem horizontal, the hydrostatic torque results from the variation in the static head of the process fluid from the top to the bottom of the pipe as shown in Figure 3-29. Depending on the direction of the hydrostatic torque and the direction of disc rotation, this torque can either assist or oppose stem rotation. Likewise, valve disc

designs with offset stems can experience significant hydrostatic torques.

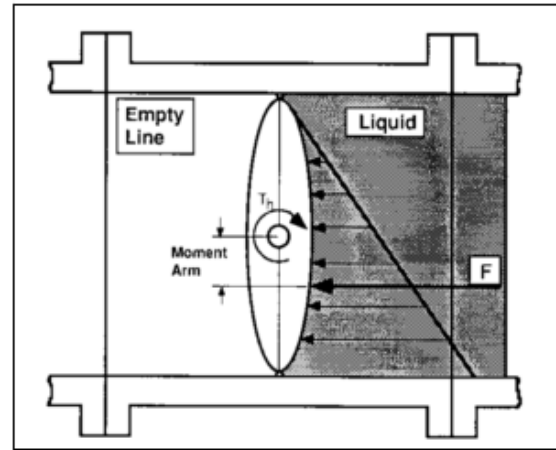

Figure 3-29 Hydrostatic Torque Load

In general, hydrostatic torque becomes very small and is often neglected for the following conditions:

- Valve stem is vertical. This orientation results in zero moment for symmetrical and single offset discs, and a negligible moment for a majority of the double offset.
- Liquid levels in both the upstream and downstream pipes are the same (either full, empty, or partially full).
- Process fluid is air, gas, or steam.

In some large valves, the hydrostatic torque component can be high enough to overcome the total seating/unseating torque. In the absence of the valve actuator resistance, the valve may open by itself.

Total Dynamic Torque

The total torque required to operate a butterfly valve is the sum of three components as shown in the following equation.

$$T_{TD} = T_{\text{Bearing}} + T_{\text{Packing}} + T_{\text{Hydrodynamic}}$$

Equation (3-19)

The bearing and packing torque are both friction related and oppose the stem rotation for both the closing and opening directions. The hydrodynamic torque ($T_{\text{Hydrodynamic}}$) can be in either direction depending on the disc design, valve orientation to the flow stream, and even the nearby piping configuration. The major characteristic of the hydrodynamic torque is that it always acts in a particular direction regardless of the direction of stem rotation. The hydrodynamic torque direction will be

- self-closing for symmetric discs and for nonsymmetric discs installed with the shaft upstream (curved face forward),
- self-opening over a portion of the stroke or the entire stroke for nonsymmetric discs installed with the shaft downstream (flat face forward).

The actual performance depends upon the disc design and flow conditions. Upstream flow disturbances, such as pipe elbows, can have a strong influence on the

direction and magnitude of the hydrodynamic torque.

Hydrodynamic torque ($T_{\text{Hydrodynamic}}$)

Flow around a butterfly valve disc produces both lift and drag forces similar to the forces acting on an airplane wing. The nonuniform pressure distribution on the upstream and downstream faces of the disc has a resultant force that does not pass through the stem axis, as shown in Figure 3-30.

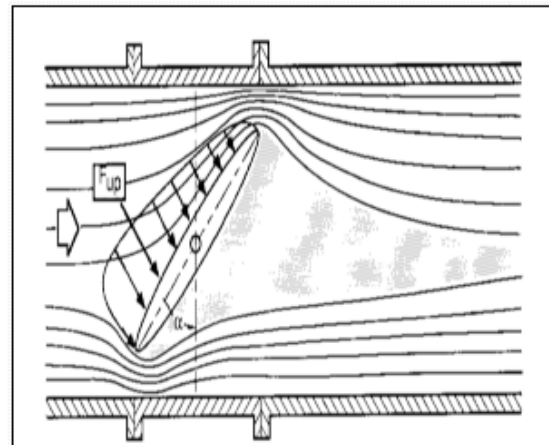

Figure 3-30 Resultant Force from Nonuniform Pressure Distribution

The product of this resultant force and its moment arm is the hydrodynamic torque. For a given disc shape, the hydrodynamic torque is proportional to the valve pressure drop, and disc diameter cubed as follows.

$$T_{\text{Hydrodynamic}} = C_t d^3 \Delta P$$

Equation (3-20)

Where:

C_t = hydrodynamic torque coefficient
(dimensionless)

d = valve nominal diameter

ΔP = differential pressure across the valve.

To simplify sizing butterfly valves, manufacturers use hydrodynamic torque coefficients that are based on the valve nominal diameter instead of the disc diameter. Most manufacturers determine their torque (and flow) coefficients by performing flow loop test on valves of selected sizes and pressure ratings, or on scaled models of their product line. The tests are typically performed under fully turbulent, non-choked flow conditions using water, or with air using low pressure drop ratio conditions (flow velocity well below the speed of sound) to simulate nearly incompressible flow. Due to test facility limitations, valve sizes are typically small, four to eight-inch diameter.

Limited verification of extrapolation techniques by flow loop testing has been done by some manufacturers and laboratories for valve sizes in the 18 to 24-inch range. Extrapolation techniques are often justified by satisfactory performance under normal operating conditions. However, test data at or near design basis conditions (i.e. high flow rates under blowdown) are limited..

Incompressible flow

Figure 3-31 shows typical incompressible flow hydrodynamic torque coefficients for symmetric disc butterfly valves and both orientations of nonsymmetric disc butterfly valves. The torque coefficient is given as a function of disc opening angle, with 0 degrees being the closed position. Positive values of the hydrodynamic torque coefficient indicate a self-closing torque, whereas negative values indicate self-opening torque. It should be stressed that even though the peak in the non-dimensional hydrodynamic torque

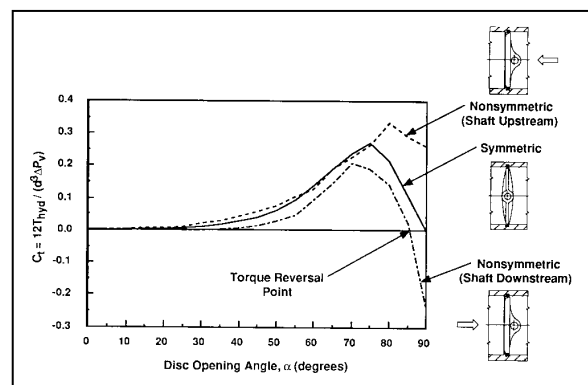

Figure 3-31 Typical Incompressible Flow Disc Butterfly Valves

coefficient occurs near 70 degrees, the actual peak in hydrodynamic torque will be at this location only if the differential pressure across the valve is constant. In most applications, the differential pressure across the valve is not constant and the disc angle associated with the peak hydrodynamic torque will shift.

For symmetric disc butterfly valves, the hydrodynamic torque coefficient is self-closing throughout the stroke. It is zero at the fully closed position, reaches a maximum near 70 degrees, and returns to zero at the fully open position. For nonsymmetric disc butterfly valves, the torque coefficient depends on flow direction. The shaft upstream orientation is characterized by a slightly higher peak value at a slightly greater angle than the symmetric disc. The torque coefficient does not drop to zero at the fully open position because the disc geometry is nonsymmetric with respect to the flow field, resulting in a net closing moment on the stem.

A nonsymmetric disc butterfly valve with the shaft oriented downstream produces a significantly lower, but positive peak at about 60 degrees, and a negative torque coefficient (self-opening) beyond 80 degrees. At the fully open position, the disc has a negative torque coefficient due to its nonsymmetric shape with respect to the flow field. The magnitude of the hydrodynamic torque coefficient at full open position with the shaft downstream is equal in magnitude, but opposite in sign, to its value with the shaft upstream.

Compressible flow

Butterfly valve hydrodynamic torque under compressible flow is more complicated to predict and the analysis is beyond the scope of this course. It is often

referred to as aerodynamic torque by the industry. Limited testing performed on symmetric and nonsymmetric butterfly valve designs under compressible flow conditions shows important performance differences from incompressible flow. The differences include:

- The effect of fluid compressibility on the mass flow rate is significant, even before choked flow (sonic velocity) conditions are reached.
- With constant upstream pressure, a terminal value of pressure drop ratio is reached beyond which any further increase in the pressure drop by decreasing the downstream pressure causes no further increases in mass flow rate.
- Continued increase in pressure drop ratio beyond the initiation of choked flow conditions causes changes in the locations of the stagnation point near the leading edge of the disc, the shock front, the separation point, and the reattachment point of flow around the disc. The resultant pressure distribution and hydrodynamic torque are sensitive to all of the above factors, which in turn depend on disc shape, the disc opening angle, the flow direction, and the amount of seat offset.
- With shaft upstream and at a given disc angle, hydrodynamic torque increases with continued increase in

pressure drop ratio, reaching a saturation level beyond choking.

- With shaft downstream, nonsymmetric discs typically exhibit a negative torque (self-opening) throughout the stroke at pressure ratios beyond choking. At pressure ratios below choking and approaching choked flow conditions, the torque is initially self-closing; it gradually reaches a peak in the self-closing direction, and then reverses as pressure drop ratio is increased beyond choking. It should be noted that, under design basis conditions, the typical operation of butterfly valves in containment purge and vent applications is under choked flow conditions.

Effects of flow disturbances

The hydrodynamic torque characteristics discussed earlier in this course are based on a uniform approach velocity encountered in a long straight pipe. Any flow disturbance can significantly affect the magnitude of the hydrodynamic torque component in butterfly valves. The presence of an upstream disturbance is most often accounted for by a multiplying factor:

$$T'_{Hydrodynamic} = C_{up} T_{Hydrodynamic}$$

Equation (3-21)

Where

$T'_{Hydrodynamic}$ = hydrodynamic torque with an upstream disturbance

$T_{Hydrodynamic}$ = hydrodynamic torque with no upstream disturbance

C_{up} = factor to account for the effect of an upstream disturbance

The magnitude of the upstream disturbance effect depends upon:

- the type of flow disturbance (e.g. elbow, pump, or tee),
- its orientation with respect to the valve stem axis (parallel or perpendicular) and the direction of operation (clockwise or counterclockwise),
- its proximity to the valve,
- the disc opening angle, and
- the direction of hydrodynamic torque (self-closing or self-opening).

Figure 3-32 shows examples of how an upstream flow disturbance, in this example an elbow, might alter the velocity profile with reference to disc orientation. The uniform velocity profile encountered in a straight pipe acquires a skew as it exits an elbow. The higher velocity on one side of the pipe can cause an increase, a decrease, or a negligible effect on the hydrodynamic torque, depending upon the relative orientation between the elbow plane and the valve stem axis as well as the direction of rotation of the valve disc.

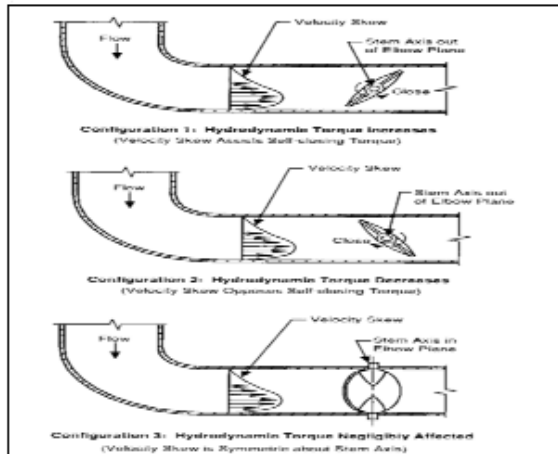

Figure 3-32 Velocity Profiles with Upstream Flow Disturbance

through the valve. Therefore, no adjustments in hydrodynamic torque are needed to account for their presence.

The published data to address the effect of upstream disturbances on butterfly valve hydrodynamic torque are limited. Present state-of-the-art guidance includes:

- For compressible flow under choked flow conditions, a factor of 1.5 to account for elbow effects was identified by the INEEL purge and vent valve tests performed on two 8-inch valves and one 24-inch valve.
- For incompressible flow, one manufacturer reports data varying from the most severe factor of 1.5 for a pump to 1.3 for an elbow or a tee. Another manufacturer states that at the discharge of a pump, the unsymmetric flow can result in a hydrodynamic torque up to twice its magnitude in straight pipe.

In general, the presence of a downstream disturbance has a negligible effect on the velocity profile of the flow

