

PSEG NUCLEAR L.L.C.

**METEOROLOGICAL MONITORING SYSTEM CALIBRATION AND
MAINTENANCE**

REVISION SUMMARY:

- ◆ This is a new procedure, no revision bars were used.
 - ◆ This procedure supersedes NC.CH-SC.MET-1206(Q), Meteorological Monitoring System Calibration and Maintenance, IAW Order #70079685-1990. No commitments have been changed or deleted. This is an OEM consolidation activity.
 - ◆ DCP 80067994, which implements the HC SPDS computer replacement, is incorporated in this revision.
 - ◆ DCP 80095184, which implements the MET System new devices and MET Tower modification, is incorporated in this revision.
 - ◆ Subsection 5.4 adds information for Wind Direction and Speed sensor exchange.
 - ◆ Subsection 5.5 adds information for annual inspection frequencies for the tower and once per three year inspection frequency for the guy wire anchors.
 - ◆ Due to the technical content and complexity of usage of this document, some deviations to the AD-AA-101 formatting process were approved by the CFAM.
-

METEOROLOGICAL MONITORING SYSTEM CALIBRATION AND MAINTENANCE

TABLE OF CONTENTS

| <u>Section</u> | <u>Title</u> | <u>Page</u> |
|-----------------|--------------------------------------------------------------------|-------------|
| 1.0 | PURPOSE..... | 2 |
| 2.0 | PREREQUISITES | 2 |
| 3.0 | PRECAUTIONS & LIMITATIONS | 2 |
| 4.0 | EQUIPMENT/ MATERIAL REQUIRED..... | 3 |
| 5.0 | PROCEDURE | 4 |
| 5.1 | Monthly Maintenance Checks | 4 |
| 5.2 | Pre-Calibration Set Up..... | 7 |
| 5.3 | Calibrations..... | 7 |
| 5.4 | Annual Sensor Exchange | 14 |
| 5.5 | Tower Functional Checks | 14 |
| 5.6 | Return To Service..... | 15 |
| 6.0 | RECORDS | 16 |
| 7.0 | REFERENCES..... | 16 |
| 8.0 | GLOSSARY | 17 |
| ATTACHMENTS | | |
| | Attachment 1, Wind Sensor Components | 18 |
| | Attachment 2, Wind Sensor Mounting Options | 19 |
| | Attachment 3, Met Parameters | 20 |
| | Attachment 4 Wind Sensor Alignment | 24 |
| EXHIBITS | | |
| | Exhibit 1, Meteorological Monitoring Display System | 25 |
| | Exhibit 2, Meteorological Monitoring Data Acquisition System | 27 |
| | Exhibit 3, Meteorological Tower..... | 28 |
| | Exhibit 4, Support System Contacts..... | 29 |
| FORMS | | |
| | Form 1, Test Equipment List..... | 31 |
| | Form 2, Meteorological Tower Calibration | 33 |
| | Form 3, Monthly Maintenance Check Sheet..... | 34 |

1.0 **PURPOSE**

- 1.1 Provide calibration instruction during system calibration and preventive maintenance activities.
- 1.2 Provide instruction for Meteorological Monitoring System repair.
- 1.3 Provide instruction for monthly system performance checks.

2.0 **PREREQUISITES**

- 2.1 Personnel performing the calibrations described in this procedure should have a comprehensive knowledge of the Meteorological Monitoring System.
- 2.2 Prior to performing system calibration or maintenance, **NOTIFY** Salem Unit 1 and Hope Creek Control Rooms.
- 2.3 Work on the Meteorological Monitoring System requires a valid Order.
- 2.4 A full set of sonic wind sensors must be available for system calibration as calibration is performed by a wind tunnel test at an approved facility.

3.0 **PRECAUTIONS AND LIMITATIONS**

- 3.1 IF it is suspected that test equipment is not performing properly, THEN PERFORM a comparison check with a similar device OR CHECK the device for calibration against a standard. This should be done prior to taking any other corrective actions.
- 3.2 IF deficiencies are encountered during the performance of the procedure, THEN REPORT the deficiency to the job supervisor AND CREATE a notification IAW LS-AA-120, Issue Identification and Screening Process. **NOTE** these deficiencies and any corrective action (repairs or commitments to rework) in the REMARKS section of the Data Package Cover Sheet.
- 3.3 IF "AS FOUND" data is unobtainable, THEN NOTE the reason on the appropriate data sheet Index.
- 3.4 Equipment repair is limited to meteorological instrument components (e.g., meteorological sensors, signal processing circuit boards, data loggers) for which a "like for like" replacement can be accomplished.
- 3.5 Any major equipment replacement should be done IAW with CC-AA-103, Configuration Change Control for Permanent Physical Plant Changes.
- 3.6 **REPLACE** delta temperature thermistors only in matching sets.

- 3.7 Specific instruments on the main tower provide signals that are not transmitted to the Salem and Hope Creek stations. Reference Attachment 3.
- 3.8 This procedure maybe completed in whole or in part. Applicable steps within a section should be completed prior to starting the next section. When individual sections are performed out of sequence the applicable pre-requisite conditions for that section must still be met. The maintenance supervisor should determine which sections and what steps are to be performed.

4.0 **EQUIPMENT/MATERIALS REQUIRED**

- 4.1 Meters or electronic test equipment used for calibration and/or repair should be NIST traceable and calibrated by the Measurements & Test Equipment (M&TE) Lab.
- 4.2 The following equipment is required:

NOTE: Calibration of the Met One or RTP 2000 data loggers is a separate activity and is performed under separate contract administrated by PSEG Nuclear Digital Systems Group.

- ◆ Functional MET-A & Met-B DAS (PC hardware).
- ◆ Met One Instrument Manual (VTD 325493) Ref. 7.1
- ◆ Sufficient number of thermos bottles with crushed ice & distilled water.
- ◆ M&TE calibrated multimeter (12 month calibration cycle)
- ◆ Safety climbing equipment
- ◆ Pulley, rope, bucket assembly
- ◆ Sound-powered head sets
- ◆ Voltage standard (12 month calibration cycle)
- ◆ Psychrometer (12 month calibration cycle)
- ◆ Soft sound-absorbent cloth
- ◆ Data Forms
- ◆ Calibration fixture – MetOne Model 70.5

5.0 **PROCEDURE**

5.1 **Monthly Maintenance Checks**

NOTE: The following section is specific to monthly PMs, display system surveillances, and instrument performance checks.

- 5.1.1 **PRIOR** to starting PMs, **CONTACT** both Salem and Hope Creek Control Rooms.
- 5.1.2 **RECORD** "As Found" readings on the monthly check sheet prior to any adjustments.
- 5.1.3 **PERFORM** channel check and any required adjustments using the appropriate section of the Met One Instrument Manual, VTD 325493.
- 5.1.4 **IF** the adjustments are minor and do not affect system calibration, **THEN PERFORM** the adjustments. **DOCUMENT** as appropriate using the SAP corrective action process. **IF** significant instruments, data logger or computer problems are found **THEN CREATE** a Notification using the appropriate SAP corrective action process.
- 5.1.5 **RECORD** "As Left" readings on the appropriate monthly check sheets Forms.
- 5.1.6 **CHECK** aspirator operation. **IF** inoperative, **THEN CREATE** a Notification IAW corrective action program **AND REPAIR** aspirator.
- 5.1.7 **CHECK** EdgeTech dew point system as follows:
- A. **CHECK** insect screen for cleanliness.
 - B. **CHECK** current dew-point reading with psychrometer readings.
 - C. **COMPARE** the EdgeTech dew point temperature with the MetOne humidity monitoring system using the appropriate conversion techniques.
 - D. **COMPARE** dew point temperature against the ambient temperature to ensure that dew point is lower.
- 5.1.8 **CHECK** solar radiation system as follows:
- A. **WIPE** the glass bulb of pyranometer clean and dry with fine muslin cloth or tissue paper.
 - B. **CHECK** spirit level to verify instrument is level.
 - C. **IF** condensation is observed, **THEN REPLACE** desiccant.

5.1.9 **CHECK** precipitation system as follows:

- A. **TEST** MetOne tipping bucket rain gauge by manually tipping bucket at 30 second intervals.
- B. **TIP** bucket 5 times.
- C. **WAIT** 15 minutes and the system will reset itself.
- D. **NOTE** the time of the test in the log book.
- E. **RECORD** any problems on the monthly maintenance check sheet.

5.1.10 Wind speed and direction reviews.

- A. **REVIEW** wind speed and direction trends using the appropriate trending functions on the MET-A, MET-B computers (i.e., TRENDS menu option or the SYSTEM FUNCTIONS, ARCHIVE RETRIEVAL menus).
- B. **REVIEW** problem log report. **TAKE** appropriate corrective action as necessary.
- C. **REVIEW INPUT CROSS CHECKS.** **TAKE** appropriate action as necessary

NOTE: Wind direction fluctuations generally decrease with height and prevailing wind speed. Wind speed generally increases with height.

- D. **RECORD** any suspected problems on monthly maintenance check sheet Form.

5.1.11 Delta Temperature reviews.

- A. **REVIEW** temperature trends for the 150-33 foot, 197-33 foot and 300-33 foot delta temperature for behavior trace using the TRENDS or the SYSTEM FUNCTIONS, Archive Retrieval menu.

NOTE: Generally, the three delta temperatures should show the same trends. The longer interval (300-33 ft.) trace will likely be more positive or negative than the 197-33 ft and the 150-33 ft. interval trace.

- B. **RECORD** any suspected problems on monthly maintenance check sheet Form as appropriate.

5.1.12 MetOne humidity check.

- A. **COMPARE** current dew-point and humidity reading with psychrometer readings.
- B. **COMPARE** the Met One humidity values with the Edge Tech dew point monitoring system using the appropriate conversion techniques.

5.1.13 Instrument power supply check

- A. **VERIFY** DC instrument power for +12v, -12v output.
- B. **USE** a voltmeter and extender board AND LOCATE test points 2, 12, & 21 using the VTD Manual Reference 7.1.
- C. Verify DC instrument power for the +15v power supplies mounted near the surge protected terminal boards for each of the wind sensor loops.
- D. **USE** a voltmeter AND LOCATE the appropriate terminals using the VTD Manual Reference 7.1.
- E. **RECORD** any suspected problems on the appropriate monthly maintenance check sheet Form.

5.1.14 Verification of Data Acquisition Operability

NOTE: List of commands and operating instructions for MET-A and MET-B DAS are located in Met One Instrument Manual (VTD 325493) and Scientech Meteorological System Users Manual.

- A. **CHECK** the System time to ensure current time. System time is displayed in the right top corner of the display screen. .

NOTE: Database time is maintained as Greenwich Mean Time (GMT) but displays will be local time.

- B. **USE** the "15 MINUTE AVERAGE DATA" menu function to check averages.
- C. **USE** the TRENDS menu to obtain current instantaneous values (use Attachment 3 to identify channel IDs of interest). THEN CHECK instantaneous input value or SYSTEM FUNCTIONS, ARCHIVE RETRIEVAL.
- D. **RECORD** any suspected problems on the appropriate monthly maintenance check sheet Form as appropriate.

5.2 Pre-Calibration Setup

- 5.2.1 **COMPLETE** Test Equipment documentation using Form-1.
- 5.2.2 **VERIFY** that power supply of translator cards provides a positive and negative 12.0 ± 0.5 vdc.
- 5.2.3 **Verify** the separately mounted 15 vdc power supplies for the wind sensor loops provide $+15$ vdc ± 0.5 vdc.
- 5.2.4 **PREPARE** a sufficient number of thermos bottles with ice-liquid mixture.
- 5.2.5 **ENSURE** that channels to be calibrated are removed from service using Data Acquisition System (DAS) software IAW Met One VTD 325493 [**Reference 7.1**]
- 5.2.6 Prior to any adjustment or repair, **RECORD "AS FOUND"** zero and span data for all channels on appropriate form.

NOTE: The Meteorological Monitor System vendor manual – Met One VTD 325493 [Ref. 7.1] – which provides detailed information on all system instruments (i.e., sensor, transmitters, translator cards, power supplies, etc.), may be used in conjunction with system calibration procedures.

5.3 Calibrations

NOTE: Procedure Section 5.3 directions are specific to system calibration. These steps may also be used for trouble shooting and other corrective maintenance activities as necessary.

NOTE: While the Salem and Hope Creek Updated Final Safety Analysis Report (UFSAR) require daily channel checks and six month channel calibration, the Stations are currently calibrating the meteorological tower instruments on a Quarterly frequency, reference order 70102140.

NOTE: USE Form 1 Test Equipment List for all calibration activities.

5.3.1 **Wind Direction System Calibrations**

NOTE: The annual sonic wind instrument calibration is performed in a wind tunnel at the manufacturer's or other approved facility. Ensure that a complete set of replacement sensors is available prior to initiating the calibration.

- A. **TAKE** the wind direction channels out of service on the Master Computer using the *Group Update* menu function.

◆ AWD300S - (*Wind Direction @ 300'*)

- ◆ AWD197S – (Wind Direction @ 197')
- ◆ AWD150S - (Wind Direction @ 150')
- ◆ AWD33S - (Wind Direction @ 33')
- ◆ AWDBUS - (Wind Direction B/U @ 33')

- B. **USE** the “15 Minute Average Data” display **AND VERIFY** that the appropriate channels indicate OS [Out of Service].
- C. **RETRACT** the instrumentation boom.

NOTE: Orientation to true North was established during installation (DCP 80035257). Wind sensor orientation can only be visibly checked (see VTD 325493 for documentation).

- D. **CHECK** alignment of MetOne 50.5 sensor using the MetOne orientation device Model 50.5. **ALIGN** the orientation device with the black and white ground marking (and 4th fence post west of the north apex of the security fence. **REFER** to Attachment 4).
- E. **USE** Met One Users Manual VTD 325493 to make the necessary adjustments.
- F. **ORIENT** the backup tower sensor using the calibration fixture [Met One Model 70.5] siting on the 3rd fence post west of the north apex of the security fence. **REFER** to Attachment 4.
- G. **IF** troubleshooting is required **THEN REFER** to Ref 7.1 **AND FOLLOW** the maintenance/ trouble shooting direction.
- H. **Every quarterly calibration, CHECK** the wind direction by covering the north-south transponder elements of the sonic sensor as directed in VTD 325493 [Attachment 1] also include east and west directions.
- I. **PERFORM** an electronic zero and span using the zero and span switches on the respective translator cards and Ref 7.1.
- J. **RECORD** the "AS LEFT" values on data calibration sheet Form-2, Meteorological Tower Calibration.
- K. **VERIFY** that heat tracing to the sensors mounted on the tower is operating properly.
- L. **PUT** the direction channels back in service on the Master Computer using the system function menu, group updates for wind direction instruments.

- M. **VERIFY** that all wind direction channels have been properly returned to service by using a suitable display menu such as MET INPUT DATA or INPUT CROSS CHECK to assure that the OS identifier is no longer present.
- N. Following every other six month calibration, **PACKAGE AND SEND** the replaced instruments to an approved facility for calibration.

5.3.2 Wind Speed System

NOTE: The annual sonic wind instrument calibration is performed in a wind tunnel at the manufacturer's or other approved facility. Assure that a complete set of replacement sensors is available prior to performing the calibration.

- A. **TAKE** the wind speed channels out of service on the Master Computer using the Group Update menu function.
- ◆ AWS300S - (*Wind Speed @ 300'*)
 - ◆ AWS197S - (*Wind Speed @ 197'*)
 - ◆ AWS150S - (*Wind Speed @ 150'*)
 - ◆ AWS33S - (*Wind Speed @ 33'*)
 - ◆ AWSBUS - (*Wind Speed B/U @ 33'*)
- B. **USE** the "15 Minute Average Data" display **AND VERIFY** that the wind speed channels indicate OS [Out of Service]
- C. **RETRACT** the instrumentation boom.
- D. **REFER** to VTD 325493 **AND FOLLOW** the wind speed translator calibration sequence.
- E. **Every quarterly calibration, CHECK** the wind speed instrument by covering wind sensor transponder elements. **IF** this is a six month calibration, **THEN PROCEED** to the next step.
- F. **MOUNT** the instrument on the appropriate boom and check as follows:
1. **VERIFY** directional alignment is correct, **THEN SECURE** sensor in mounting fixture.
 2. **CONNECT** instrument cable and heat trace cable.
 3. **COVER** sonic wind sensor IAW VTD 325493 Ref 7.1 **AND RECORD** wind speed.

4. IF the wind speed does not go full scale THEN ADJUST IAW VTD 325493.
5. **EXTEND** boom AND CLAMP in place.
- G. **RETURN** the wind speed channels to service on the computer by using the appropriate Group Update menu function.
- H. **USE** a suitable display menu such as MET INPUT DATA or INPUT CROSS CHECK AND VERIFY that the OS identifier is no longer present.
- I. Following six month calibration, **PACKAGE AND SEND** the replaced instruments to an approved facility for calibration.
- J. **RETURN** the system to normal operation.

5.3.3 EdgeTech Dew Point and Temperature System

NOTE: The EdgeTech Model 200M Dewtrack Meteorological System Operator Manual is included in the Met One Manual (Ref 7.1). This manual should be referred to for calibration and repair of the dew point monitoring system.

- A. **REFER** to Section 6.4 of the EdgeTech manual for calibration and repair of the dew point sensor.
- B. **INSPECT** the sensor insect screen and mirror. **CLEAN** if required.
- C. **RETURN** the system to normal operation.
- D. **CHECK** current dew point reading with Psychrometer reading AND CONVERT from wet bulb to dew point temperature.
- E. **RETURN** the dew point and EdgeTech temperature channels to service on the Master Computer using the SYSTEM FUNCTIONS, GROUP UPDATE menu
- F. **USE** the “15 Minute Average Data” menu AND VERIFY that the OS flag has been removed.

5.3.4 Met One Ambient, Delta Temperature and Humidity System

NOTE: The "Met One" temperature monitoring system consists of eight channels:

- ◆ Ambient temperature at 33' and 300'
- ◆ Ambient temperature at 300'
- ◆ Delta temperature 300-33'
- ◆ Delta temperature 197-33'
- ◆ Delta temperature 150-33'
- ◆ Humidity – 300'
- ◆ Humidity – 33' and 300'
- ◆ Shelter temperature

- A. **REMOVE** the temperature channels from service on the Master Computer by using the appropriate group update functions.
- B. **CHECK** the zero and span of all 8 channels.
- C. **PLACE** the thermistor probes in the ice baths.
- D. **RECORD** the "AS FOUND" values of all 8 channels on the appropriate Form.
- E. **REFER** to MetOne Instrument Manual (VTD 325493) AND PERFORM the ambient temperature calibration sequence as indicated in the manual.
- F. **RECORD** "AS LEFT" values for zero, span and the ice bath values on the appropriate Form.
- G. **REFER** to MetOne Instrument Manual (VTD 325493) AND PERFORM the delta temperature calibration sequence as indicated in Reference 7.1.
- H. **RECORD** "AS LEFT" values for zero, span and the ice bath values on the appropriate Form.
- I. **REFER** to MetOne Instrument Manual (VTD 325493) AND PERFORM the humidity calibration sequence using the M&TE calibrated psychrometer as the reference point. IF necessary, **CLEAN** the sensor element as directed in the MetOne manual. IF adjustments are required THEN PERFORM them as indicated in the manual.
- J. **RECORD** "AS LEFT" values for zero, span values on the appropriate Form.
- K. **REFER** to MetOne Instrument Manual (VTD 325493) AND as necessary, **PERFORM** the shelter temperature calibration sequence as indicated in the manual. (Shelter sensor is not part of the required parameters)

- L. **RECORD** "AS LEFT" values for zero, span and the ice bath values on the appropriate Form.
- M. **PLACE** the temperature channels back in service on the Master Computer using the appropriate System Function, Group Update menu functions.
- N. **VERIFY** that all temperature and humidity channels have been properly returned to service by viewing the "15 Minute Average Data" menu options.
- O. **VERIFY** that each temperature probe aspirator is operating by listening for the sound of the fan. IF not operating, THEN **CONSULT** VTD 325493 for troubleshooting.

5.3.5 Precipitation

- A. **REMOVE** the precipitation channel from service on the Master Computer using the appropriate Group Update menu.
- B. **RECORD** the "AS FOUND" zero and span values using the translator fixed inputs.
- C. **REMOVE** precipitation gauge cover AND **SLOWLY TIP** bucket ten times. **RECORD** "AS FOUND" values for 0.10 inches of precipitation.
- D. **REFER** to *Rainfall Calibration Sequence* and the VTD Manual for instruction on rain gauge instrument calibration.
- E. **RECORD** the "AS LEFT" values for the translator fixed input zero and span.
- F. **SLOWLY TIP** bucket 10 times. **RECORD** "AS LEFT" values for 0.10 inches of precipitation.
- G. **PLACE** the precipitation channel back in service on the Master Computer using the appropriate Group Update menu function.
- H. **USE MET INPUT DATA** OR **INPUT CROSS CHECK** AND **VERIFY** that the DAS channel no longer indicates OS.

5.3.6 Barometric Pressure

- A. **REMOVE** the barometric channel from service on the Master Computer by using appropriate Group Update menu function.
- B. PRIOR to any adjustments, **CHECK** the system zero and span.
- C. **RECORD** the "AS FOUND" values on the check sheet.
- D. **REFER** to *Pressure Calibration Sequence* and the Met One Instrument Manual (Ref 7.1) for barometric pressure instrument calibration instruction.
- E. **RECORD** the "AS LEFT" zero and span values.
- F. **RETURN** the system to normal operation.
- G. **COMPARE** the barometric pressure reading with the M&TE Lab.
- H. **RECORD** the "AS LEFT" value on the appropriate data calibration Form.
- I. **PLACE** the barometric channel back in service on the Master Computer using the appropriate Group Update menu function.
- J. **USE** the "15 Minute Average Data" to verify that the OS indication is no longer present.

5.3.7 Solar Radiation

- A. **REMOVE** the solar channel from service on the Master Computer using the appropriate Group Update menu.
- B. **RECORD** the "AS FOUND" zero and span values on the calibration check sheet.
- C. **REFER** to (Reference 7.1) instrument calibration procedure to perform the calibration of this channel.
- D. **RECORD** the "AS LEFT" zero and span values on the appropriate data calibration Form.
- E. **PLACE** the solar channel back in service on the Master Computer using the appropriate Group Update menu function.
- F. **USE** the "15 Minute Average Data" to verify that the OS indication is no longer present.

5.4 Annual Sensor Exchange

5.4.1 Wind Direction Sensors

- 5.4.1.1 **Every other six months calibration** (once per year) **REMOVE** all transmitters from the tower AND REPLACE as follows:
- 5.4.1.2 **REMOVE** sonic sensors. **REFER** to Attachment 2, *Wind Transmitter*.
- 5.4.1.3 **INSTALL** the primary tower transmitters AND ORIENT all sonic wind sensors IAW Step 5.2.1.D.
- 5.4.1.4 **INSTALL** the back-up pole transmitter AND ORIENT IAW Step 5.2.1.F

5.4.2 Wind Speed Sensors

- 5.4.2.1 **Once a year (every other six month calibration)** **REMOVE** the transmitter from the tower AND REPLACE as follows:
- 5.4.2.2 Prior to any adjustments and with the boom retracted **COVER** the sonic wind sensor AND RECORD the "AS FOUND" wind speed zero value for the digital display.
- 5.4.2.3 **DISCONNECT** instrument sensor cable and heating cable AND LOWER sensor to the ground.
- 5.4.2.4 **REPLACE** the wind speed sensors AND RETURN new sensors to the respective tower elevation.

5.5 Tower Functional Checks

| |
|------------------------------------------------------------------------------------------------------------------------------------------------------------|
| <p>Note: <u>IF</u> the tower navigation light bulbs are out, <u>THEN NOTIFY IT</u> who will contact the vendor to arrange for bulb replacement.</p> |
|------------------------------------------------------------------------------------------------------------------------------------------------------------|

- 5.5.1 **VISUALLY** check the tower lightning ground system for broken or loose cables.
- 5.5.2 **CHECK** the junction boxes for weather tight integrity.
- 5.5.3 **RECORD** any tower maintenance required on the remarks sheet.

5.5.4 **CHECK** the material condition of the tower area including:

- Weeds and grass
- Trash
- Security fence
- Signage

5.5.5 Annually **PERFORM** tower inspections to ANSI/TIA/EIA-222 standards.

5.5.6 **PERFORM** guy wire inspections annually.

5.5.7 **PERFORM** guy wire anchor inspections once per three years.

5.6 **Return to Service**

5.6.1 **ENSURE** that all systems and equipment are returned to normal operation.

5.6.2 **VERIFY** that both DAS computers display the correct local time.

5.6.3 **COMPLETE** log book entries.

5.6.4 **COMPLETE** the check sheets.

5.6.5 **MAKE** the following "RETURN TO SERVICE" notifications:

- Salem Unit 1 Control Room
- Hope Creek Control Room

5.6.6 **ENSURE** that the Order is complete and signed off.

6.0 **RECORDS**

- 6.1 **RETAIN** and **PROCESS** all records IAW RM-AA-101, Records Management Program.
- 6.2 Copies of records generated by this procedure may be stored locally for information and program support. All completed forms, i.e. completed work order and technician field notes from inspections, calibrations, etc., should be attached to the appropriate orders for proper work closeout.

7.0 **REFERENCES**

- 7.1 Salem and Hope Creek Nuclear Generating Stations Meteorological System Owners Manual, VTD 325493
- 7.2 Salem Unit 1 Nuclear Generating Station MET One Model 50.5 Wind Sensor Operation Manual, VTD 325462
- 7.3 Hope Creek UFSAR Sections 2.3 and 7.7.1.11
- 7.4 Salem UFSAR Sections 2.3, 7.2, and 7.7.2.13.
- 7.5 LS-AA-120, Issue Identification and Screening Process
- 7.6 AD-AA-101-1002, Writer's Guide and Process Guide for Procedures and T&RMs
- 7.7 NRC Regulatory Guide 1.23
- 7.8 ANS/ANSI 3.11-2000, Determining Meteorological Information At Nuclear Facilities
- 7.9 ANSI/TIA/EIA-222 Structural Standards for Steel Antenna Towers and Antenna Supporting Structures
- 7.10 NC.CH-AP.MET-1201(Q), Meteorological Monitoring Program Administration
- 7.11 NC.CH-TI.MET-1202(Q), Meteorological System Operation/ Interrogation
- 7.12 Order 80077897
- 7.13 PCR Order 70102140
- 7.14 DCP 80067994
- 7.15 DCP 80095184

7.16 **Cross-References**

- 7.16.1 CC-AA-103, Configuration Change Control for Permanent Physical Plant Changes
- 7.16.2 RM-AA-101, Records Management Program

8.0 **GLOSSARY**

- 8.1 MET-A and MET-B - Meteorological data acquisition system computers located in the meteorological monitoring system instrument building. These computers are also referred to as Met Host A and Host B in some Scientech documentation. MET-A and MET-B are standard PCs running MS Windows and Scientech software.
- 8.2 DVM - Digital Volt Meter
- 8.3 Channel Calibration - A loop calibration as defined in the Station Technical Specifications. [There are no alarms or trip functions associated with any meteorological monitoring parameter (There is an alarm associated with loss of AC power at the meteorological tower. This is not considered part of the meteorological instrument system)]
- 8.4 Surveillance - Examination of channel information to determine operability. [See Technical Specification definition for Hope Creek.]
- 8.5 PCB - Printed Circuit Board The boards are also referred to as a logic cards or translator cards. The electric components which translate an electronic signal from a meteorological instrument sensor to an output which is supplied to the data loggers and the DAS.
- 8.6 Functional check – Test performed to check the correct functional operation of the instrument being observed/ tested. The sonic wind instrument are functional check for proper operation using the procedure described in the MetOne Instrument Manual.
- 8.7 Loop Check -A loop check is performed by simulating the input to the sensor with the output displayed by the channel read out. Sonic wind instruments must be calibrated at an approved facility using a wind tunnel. Therefore loop check cannot be performed from the instrument to the data acquisition system. Wind instrument will be checked using Functional Testing. Ambient and delta temperature measurements will be loop checked from the instrument to the data acquisition computers.

ATTACHMENT 1

WIND SENSOR COMPONENTS

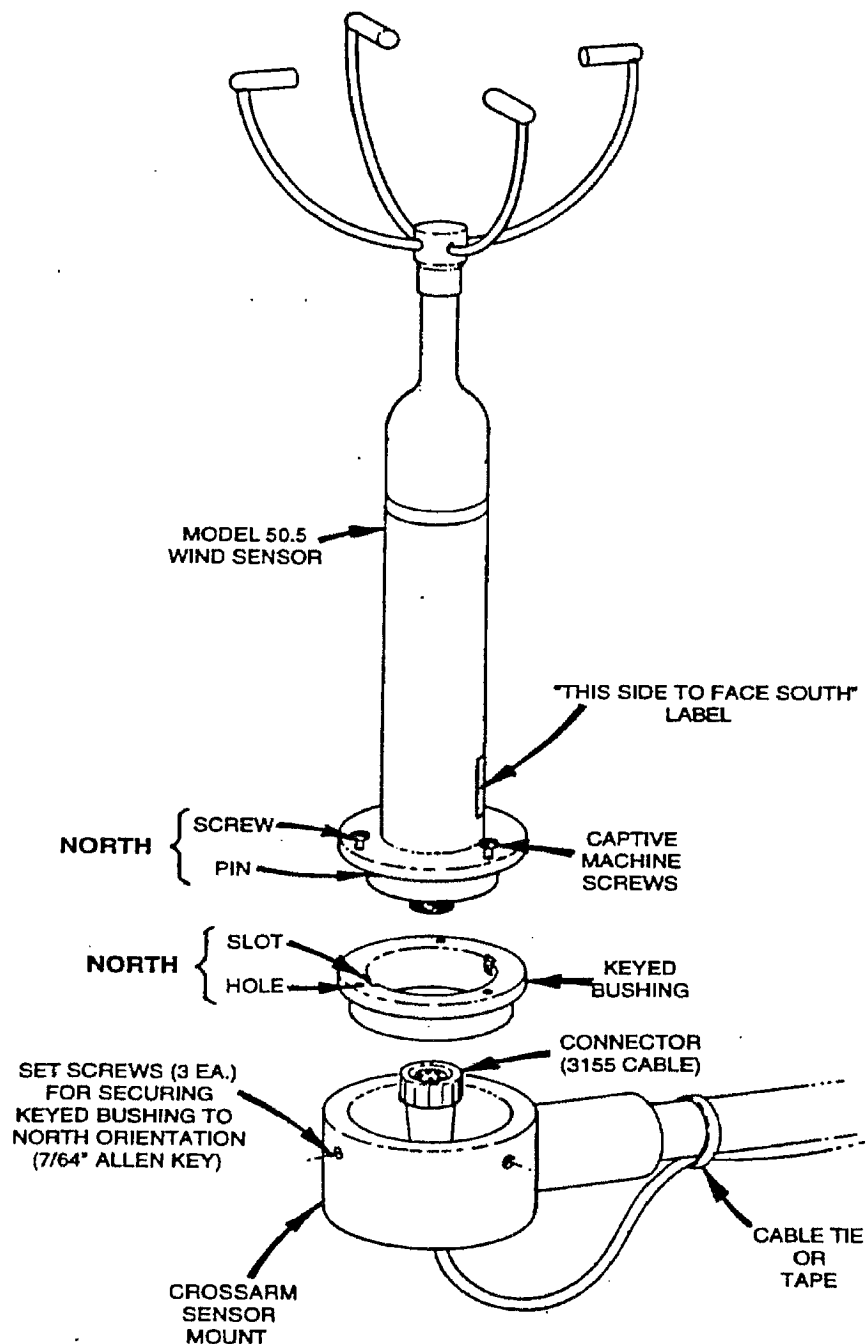

ATTACHMENT 2

WIND SENSOR MOUNTING OPTIONS

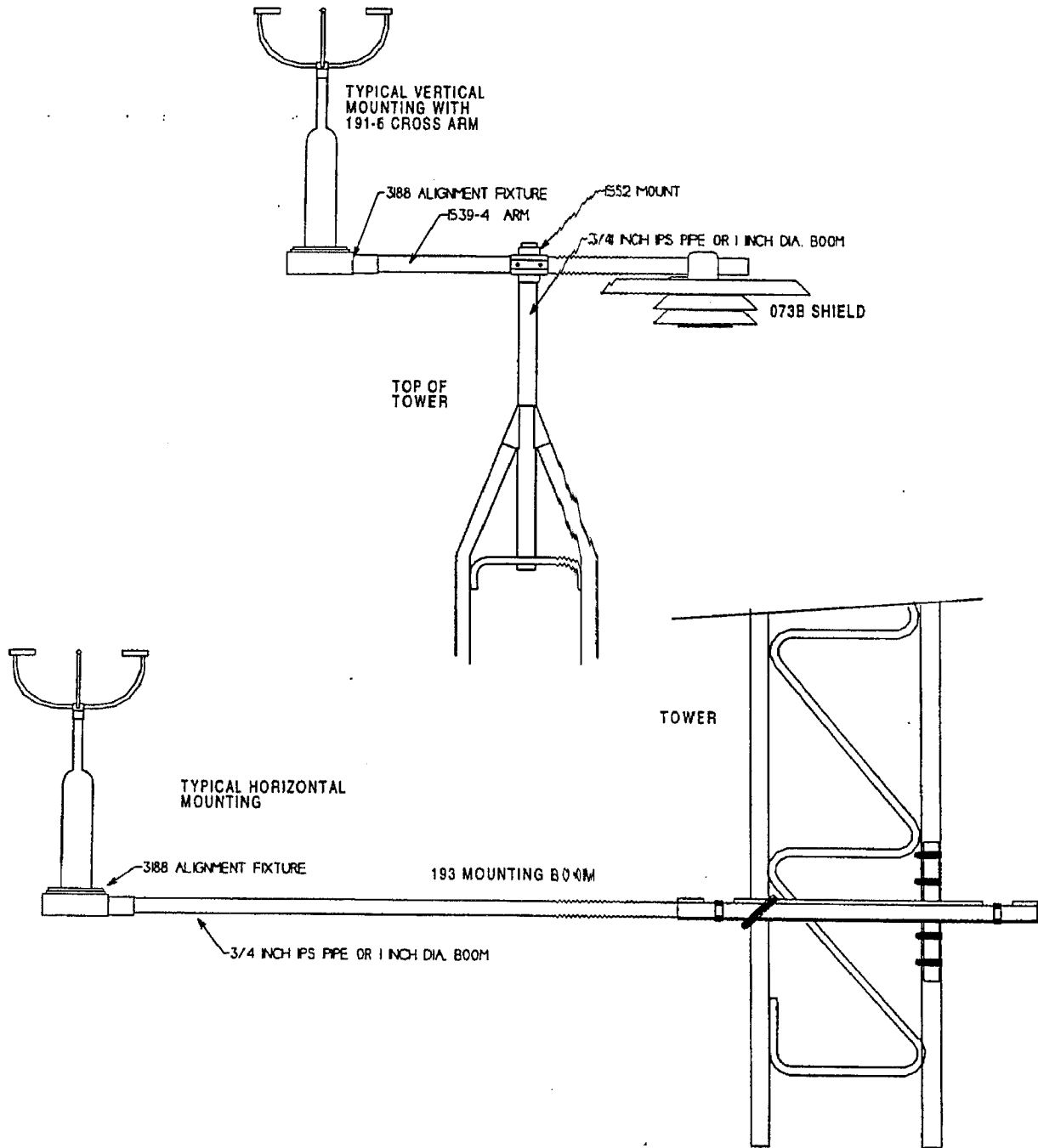

ATTACHMENT 3

Page 1 of 4

MET PARAMETERS

| | |
|-----------|---------------------------------------------------|
| AWD33DL | 0 - 33 Foot Wind Direction from Data Logger |
| AWD150DL | 1 - 150 Foot Wind Direction from Data Logger |
| AWD300DL | 2 - 300 Foot Wind Direction from Data Logger |
| AWD33RT | 3 - 33 Foot Wind Direction from RTP |
| AWD150RT | 4 - 150 Foot Wind Direction from RTP |
| AWD300RT | 5 - 300 Foot Wind Direction from RTP |
| AWS33DL | 6 - 33 Foot Wind Speed from Data Logger |
| AWS150DL | 7 - 150 Foot Wind Speed from Data Logger |
| AWS300DL | 8 - 300 Foot Wind Speed from Data Logger |
| AWS33RT | 9 - 33 foot Wind Speed From RTP |
| AWS150RT | 10 - 150 foot Wind Speed From RTP |
| AWS300RT | 11 - 300 foot Wind Speed From RTP |
| AWDBDL | 12 - Backup Tower Wind Direction from Data Logger |
| AWSBDL | 13 - Backup Tower Wind Speed from Data Logger |
| AWDBRT | 14 - Backup Tower Wind Direction from RTP |
| AWSBRT | 15 - Backup Tower Wind Speed from RTP |
| ABARODL | 16 - Barometric Pressure from Data Logger |
| ABARORT | 17 - Barometric Pressure from RTP |
| ASIG33DL | 18 - 33 Foot Sig Theta From Data Logger |
| ASIG33RT | 19 - 33 Foot Sig Theta From RTP |
| ASIG150DL | 20 - 150 Foot Sig Theta From Data Logger |
| ASIG150RT | 21 - 150 Foot Sig Theta From RTP |
| ASIG300DL | 22 - 300 Foot Sig Theta From Data Logger |
| ASIG300RT | 23 - 300 Foot Sig Theta From RTP |
| ASIGBDL | 24 - Backup Sig Theta From Data Logger |
| ASIGBRT | 25 - Backup Sig Theta From RTP |
| ATAMBDL | 26 - 33 Foot Ambient Temp from Data Logger |
| ATAMBRT | 27 - 33 Foot Ambient Temp from RTP |
| ADT300DL | 28 - Delta T from 300-33 Foot Level - Data Logger |
| ADT300RT | 29 - Delta T From 300-33 Foot Level - RTP |
| ADT150DL | 30 - Delta T From 150-33 Foot Level - Data Logger |
| ADT150RT | 31 - Delta T From 150-33 Foot Level - RTP |
| ASOLDL | 32 - Solar Radiation From Data Logger |
| ASOLRT | 33 - Solar Radiation From RTP |
| ADEWDL | 34 - 33 Foot Dew Point From Data Logger |
| ADEWRT | 35 - 33 Foot Dew Point From RTP |
| ARHDL | 36 - 33 Foot Relative Humidity from Data Logger |
| ARHRT | 37 - 33 Foot Relative Humidity from RTP |
| APRECIPDL | 38 - Precipitation From Data Logger |
| APRECIPRT | 39 - Precipitation From RTP |

The following parameters are available at the Meteorological System DAS in the Met Shelter and are not transmitted to the Salem or Hope Creek Stations:

| | |
|-----------|---------------------------------------------------|
| ADT197DL | 40 - Delta T from 197-33 Foot Level - Data Logger |
| ADT197RT | 41 - Delta T from 197-33 Foot Level - RTP |
| ATAM300DL | 42 - Ambient Temp 300 Foot Level - Data Logger |
| ATAM300RT | 43 - Ambient Temp 300 Foot Level - RTP |
| AWD197DL | 44 - 197 Foot Wind Direction from Data Logger |
| AWD197RT | 45 - 197 Foot Wind Direction from RTP |
| AWS197DL | 46 - 197 Foot Wind Speed from Data Logger |
| AWS197RT | 47 - 197 Foot Wind Speed from RTP |
| ARH300DL | 48 - 300 Foot Relative Humidity from Data Logger |
| ARH300RT | 49 - 300 Foot Relative Humidity from RTP |
| ASIG197DL | 50 - 197 Foot Sigma Theta from Data Logger |
| ADEW300DL | 51 - 300 Foot Dew Point from Data Logger |

ATTACHMENT 3
Page 2 of 4

MET PARAMETERS

The following 16 outputs are 15-minute average data points that duplicate the signals in the current MET system.

| | | | |
|-------|---------------------------------|-------|----------------------------------------|
| A9800 | 0 Wind Speed @33 FT 15-Min Avg | A9811 | 8 Barometric Pressure 15-Min Avg |
| A9801 | 1 Wind Speed @150 FT 15-Min Avg | A9812 | 9 Net Solar Radiation 15-Min Avg |
| A9802 | 2 Wind Speed @300 FT 15-Min Avg | A9991 | 10 Ambient Temp @33 FT 15-Min Avg |
| A9803 | 3 Wind Dir @33 FT 15-Min Avg | A9992 | 11 Dew Point @33 FT 15-Min Avg |
| A9804 | 4 Wind Dir @150 FT 15-Min Avg | A9993 | 12 Δ Temp 150-33 FT 15-Min Avg |
| A9805 | 5 Wind Dir @150 FT 15-Min Avg | A9994 | 13 Δ Temp 300-33 FT 15-Min Avg |
| A9806 | 6 Backup Wind Speed 15-Min Avg | A9998 | 14 Relative Humidity @33 FT 15-Min Avg |
| A9807 | 7 Backup Wind Dir 15-Min Avg | A9999 | 15 15-Minute Total Precipitation |

The following parameters are available at the Meteorological System DAS in the Met Shelter and are not transmitted to the Salem or Hope Creek Stations:

| | |
|-------|------------------------------------|
| A9900 | 16 Wind Dir @197 FT 15-Min Avg |
| A9901 | 17 Wind Speed @197 FT 15-Min Avg |
| A9902 | 18 Ambient Temp @300 FT 15-Min Avg |
| A9903 | 19 Relative Humidity @300 FT |
| A9904 | 20 Δ Temp 197-33 FT 15-Min Avg |

The following 16 outputs are 15-minute rolling average data points.

| | | |
|--------|---|---------------------------------------|
| A9800R | 0 | Wind Speed @33 FT 15-Min Rolling Avg |
| A9801R | 1 | Wind Speed @150 FT 15-Min Rolling Avg |
| A9802R | 2 | Wind Speed @300 FT 15-Min Rolling Avg |
| A9803R | 3 | Wind Dir @33 FT 15-Min Rolling Avg |
| A9804R | 4 | Wind Dir @150 FT 15-Min Rolling Avg |
| A9805R | 5 | Wind Dir @150 FT 15-Min Rolling Avg |

ATTACHMENT 3
Page 3 of 4

MET PARAMETERS

| | | |
|--------|----|-----------------------------------------|
| A9806R | 6 | Backup Wind Speed 15-Min Rolling Avg |
| A9807R | 7 | Backup Wind Dir 15-Min Rolling Avg |
| A9811R | 8 | Barometric Pressure 15-Min Rolling Avg |
| A9812R | 9 | Net Solar Radiation 15-Min Rolling Avg |
| A9991R | 10 | Ambient Temp 15-Min Rolling Avg |
| A9992R | 11 | Dew Point 15-Min Rolling Avg |
| A9993R | 12 | Delta Temp 150-33 FT 15-Min Rolling Avg |
| A9994R | 13 | Delta Temp 300-33 FT 15-Min Rolling Avg |
| A9998R | 14 | Relative Humidity 15-Min Rolling Avg |
| A9999R | 15 | 15- Minute Total Precipitation |

The following parameters are available at the Meteorological System DAS in the Met Shelter and are not transmitted to the Salem or Hope Creek Stations:

| | | |
|---------|----|-----------------------------------------------|
| A9900H | 16 | Wind Dir @197 FT 15-Min Avg - Hourly |
| A9900R | 17 | Wind Dir @197 FT 15-Min Avg – Rolling |
| A9900RT | 18 | Wind Dir @197 FT 15-Min Avg – Rolling Towards |
| A9900S | 19 | Wind Dir @197 FT 15-Min Avg – Selected |
| A9900T | 19 | Wind Dir @197 FT 15-Min Avg – Towards |
| A9901H | 20 | Wind Speed @197 FT 15-Min Avg - Hourly |
| A9901R | 21 | Wind Speed @197 FT 15-Min Avg – Rolling |
| A9901S | 22 | Wind Speed @197 FT 15-Min Avg – Selected |
| A9902H | 23 | Ambient Temp @300 FT 15-Min Avg - Hourly |
| A9902R | 24 | Ambient Temp @300 FT 15-Min Avg – Rolling |
| A9902S | 25 | Ambient Temp @300 FT 15-Min Avg – Selected |
| A9904H | 26 | Delta Temp @197-33 FT 15-Min Avg - Hourly |
| A9904R | 27 | Delta Temp @197-33 FT 15-Min Avg – Rolling |
| A9904S | 28 | Delta Temp @197-33 FT 15-Min Avg – Selected |

The following group of signals are used to produce X-Y plot data for wind vectors

| | |
|----------|-----------------------|
| AWD33XV | 0 – 33 Foot X vector |
| AWD33YV | 1 – 33 foot Y vector |
| AWD150XV | 2 - 150 Foot X vector |
| AWD150YV | 3 - 150 Foot Y vector |
| AWD300XV | 4 - 300 Foot X vector |
| AWD300YV | 5 - 300 Foot Y vector |

ATTACHMENT 3

Page 4 of 4

MET PARAMETERS

The following points are 15 minute standard deviation calculation results

| | |
|-------|--------------------------------------|
| A9813 | 0 Backup Sig Theta @33 FT 15-Min Avg |
| A9995 | 1 Sig Theta @33 FT 15-Min Avg |
| A9996 | 2 Sig Theta @150 FT 15-Min Avg |
| A9997 | 3 Sig Theta @300 FT 15-Min Avg |

The following parameters are available at the Meteorological System DAS in the Met Shelter and are not transmitted to the Salem or Hope Creek Stations:

| | |
|--------|-------------------------------------------|
| A9905 | 4 Sig Theta @197 FT 15-Min Avg |
| A9905H | 5 Sig Theta @197 FT 15-Min Avg - Hourly |
| A9905R | 6 Sig Theta @197 FT 15-Min Avg - Rolling |
| A9905S | 7 Sig Theta @197 FT 15-Min Avg - Selected |

The following points are the PASQUILL Stability Class Points

| | |
|-------------|------------------------------------------|
| APASQ33 | 0 Pasquill Stability Class - 33ft |
| APASQ150 | 1 Pasquill Stability Class - 150ft |
| APASQ300 | 2 Pasquill Stability Class - 300ft |
| APASQ33B | 3 Pasquill Stability Class - 33ft Backup |
| APASQUILL | 4 Selected Pasquill Stability Class |
| APASQDT1505 | Delta T stability class, 150 FT |
| APASQDT3006 | Delta T stability class, 300 FT |

The following parameters are available at the Meteorological System DAS in the Met Shelter and are not transmitted to the Salem or Hope Creek Stations:

| | |
|------------|------------------------------------------------------|
| APASQ197 | 7 Pasquill Stability Index – Rolling – 197ft |
| APASQ197A | 8 Pasquill Stability Index – 197 ft |
| APASQDT197 | 9 Delta T Pasquill Stability Index – Rolling – 197ft |
| APASQDT197 | 10 Delta T Pasquill Stability Index – 197ft |

ATTACHMENT 4
WIND SENSOR ALIGNMENT

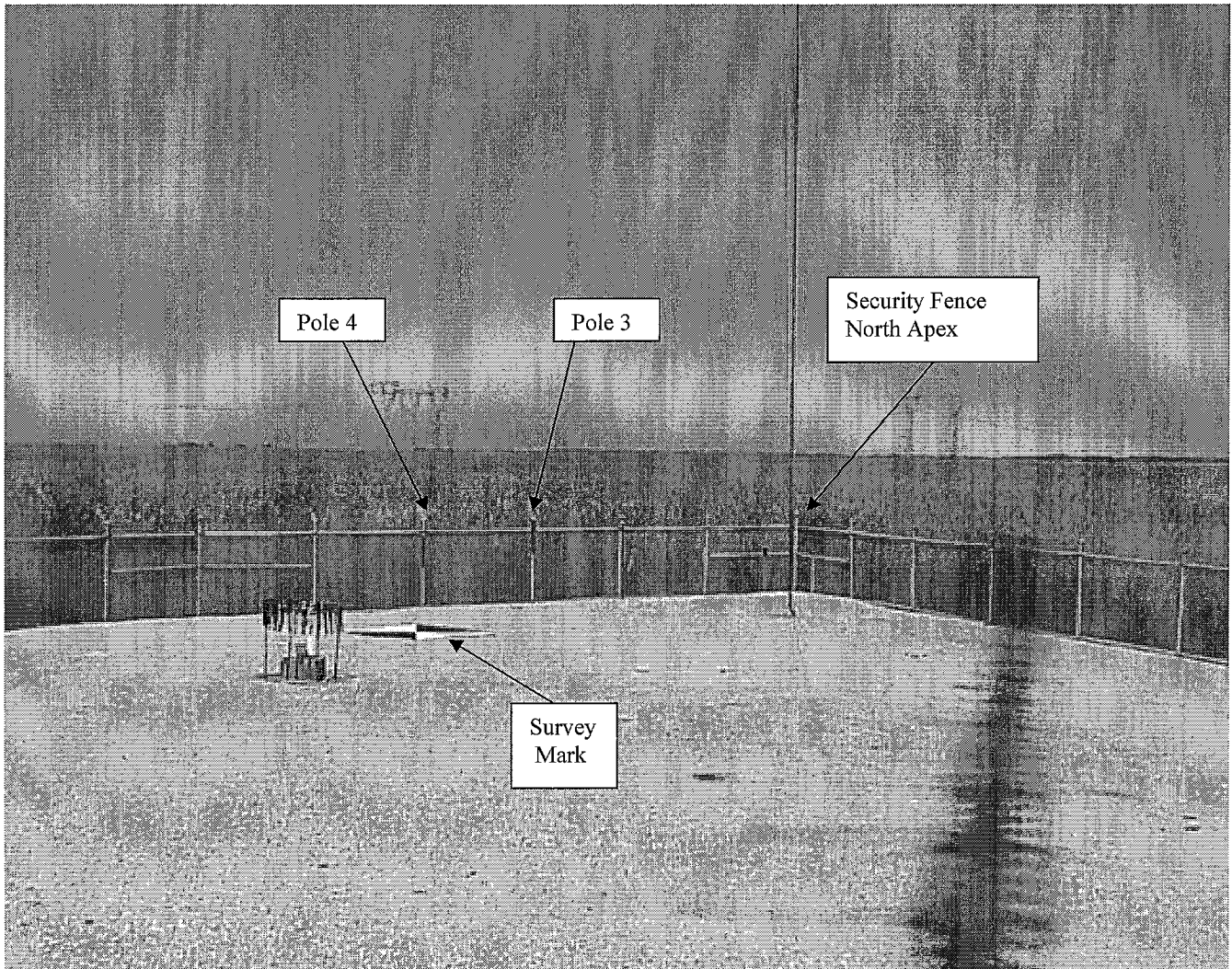
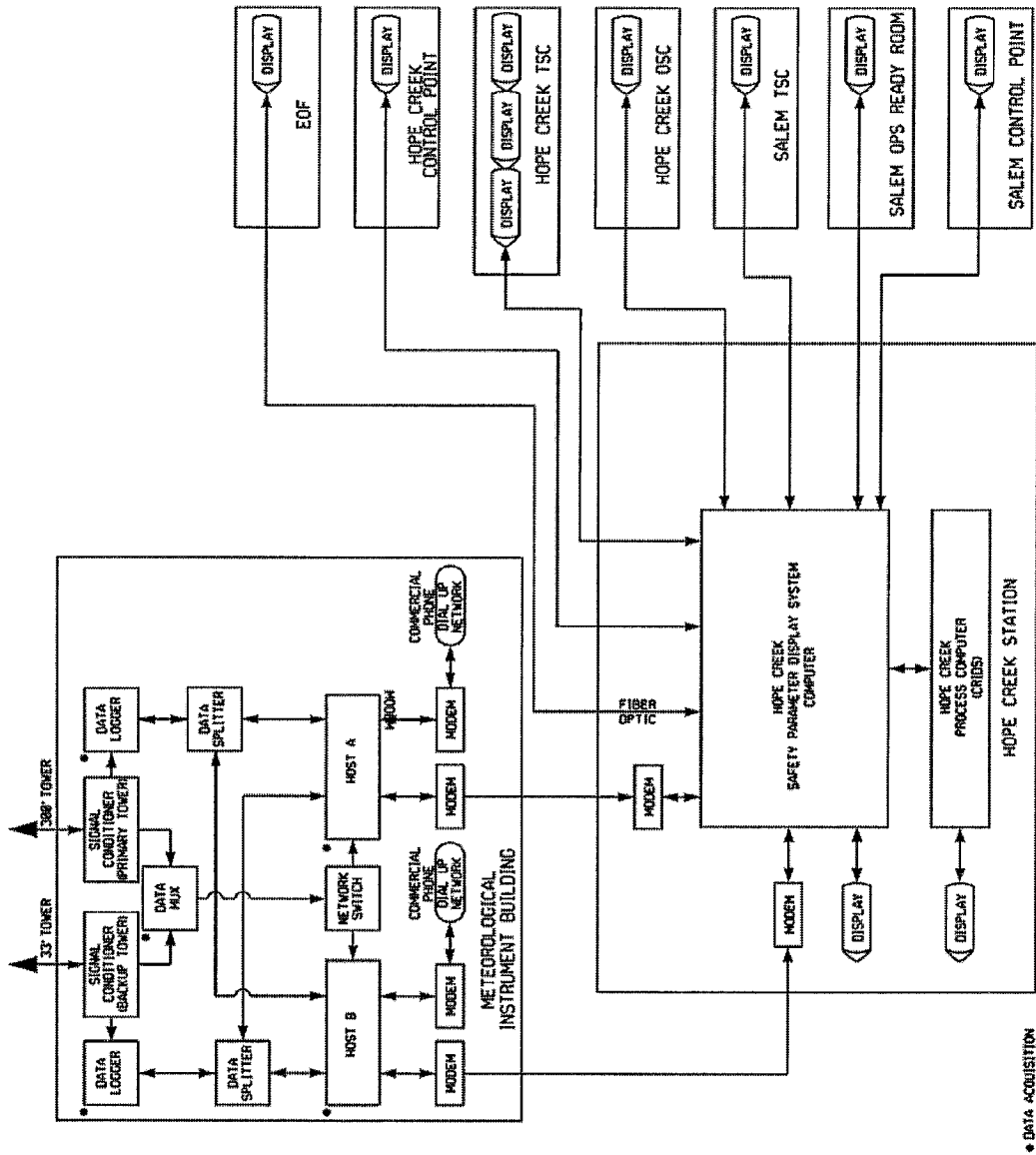

EXHIBIT 1

METEOROLOGICAL MONITORING DISPLAY SYSTEM



Revision 17, June 23, 2009

| | |
|------------------------------------------------------------|--------------------------------------------------------------------------------------------|
| PSEG Nuclear, LLC HOPE CREEK NUCLEAR GENERATING STATION | Hope Creek Nuclear Generating Station METEOROLOGICAL DATA ACQUISITION DISPLAY SYSTEM |
| | Updated FSAR Figure 2.3-6 |

© 2009 PSEG Nuclear, LLC. All Rights Reserved.

EXHIBIT 1

METEOROLOGICAL MONITORING DISPLAY SYSTEM

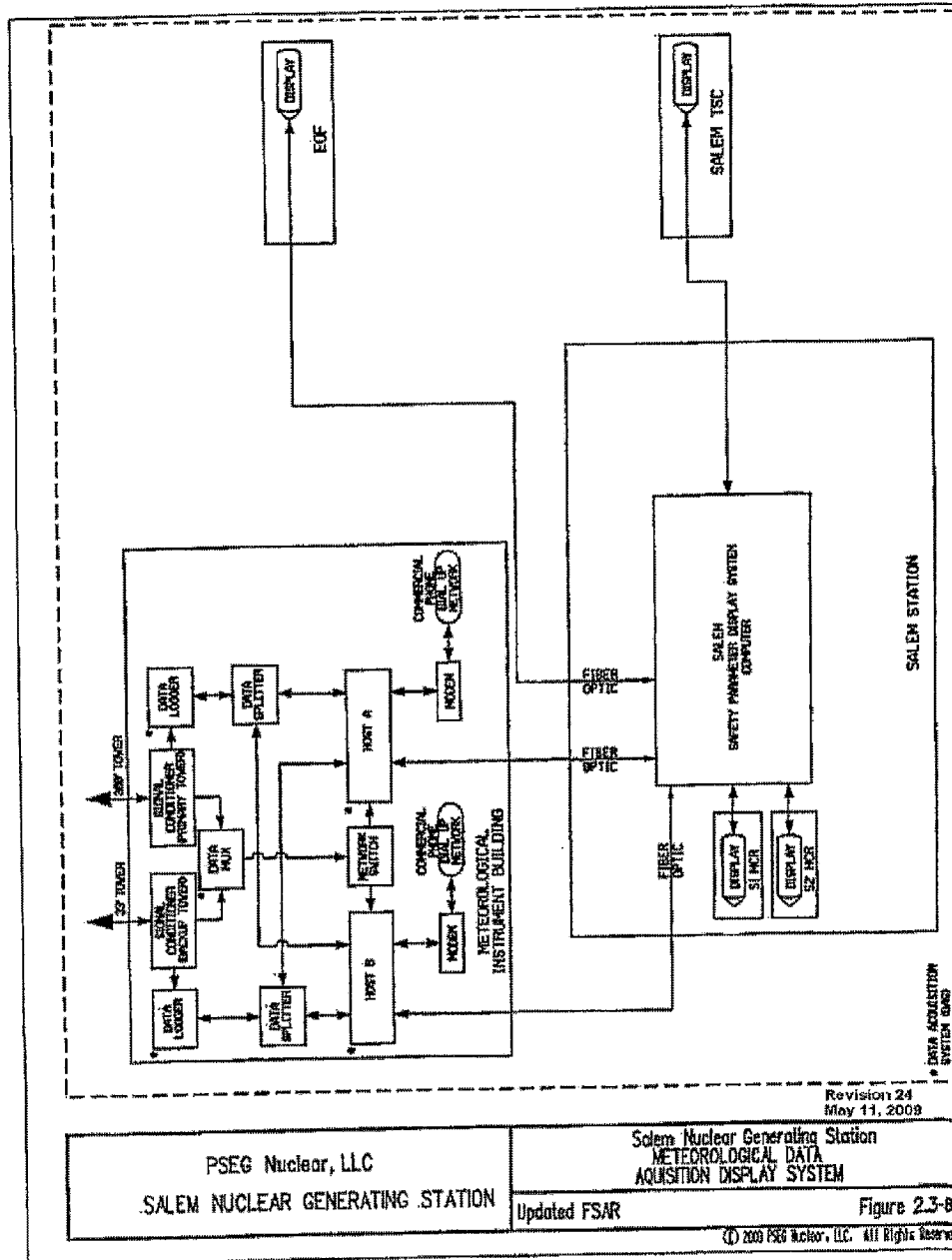

EXHIBIT 2

METEOROLOGICAL MONITORING DATA ACQUISITION SYSTEM

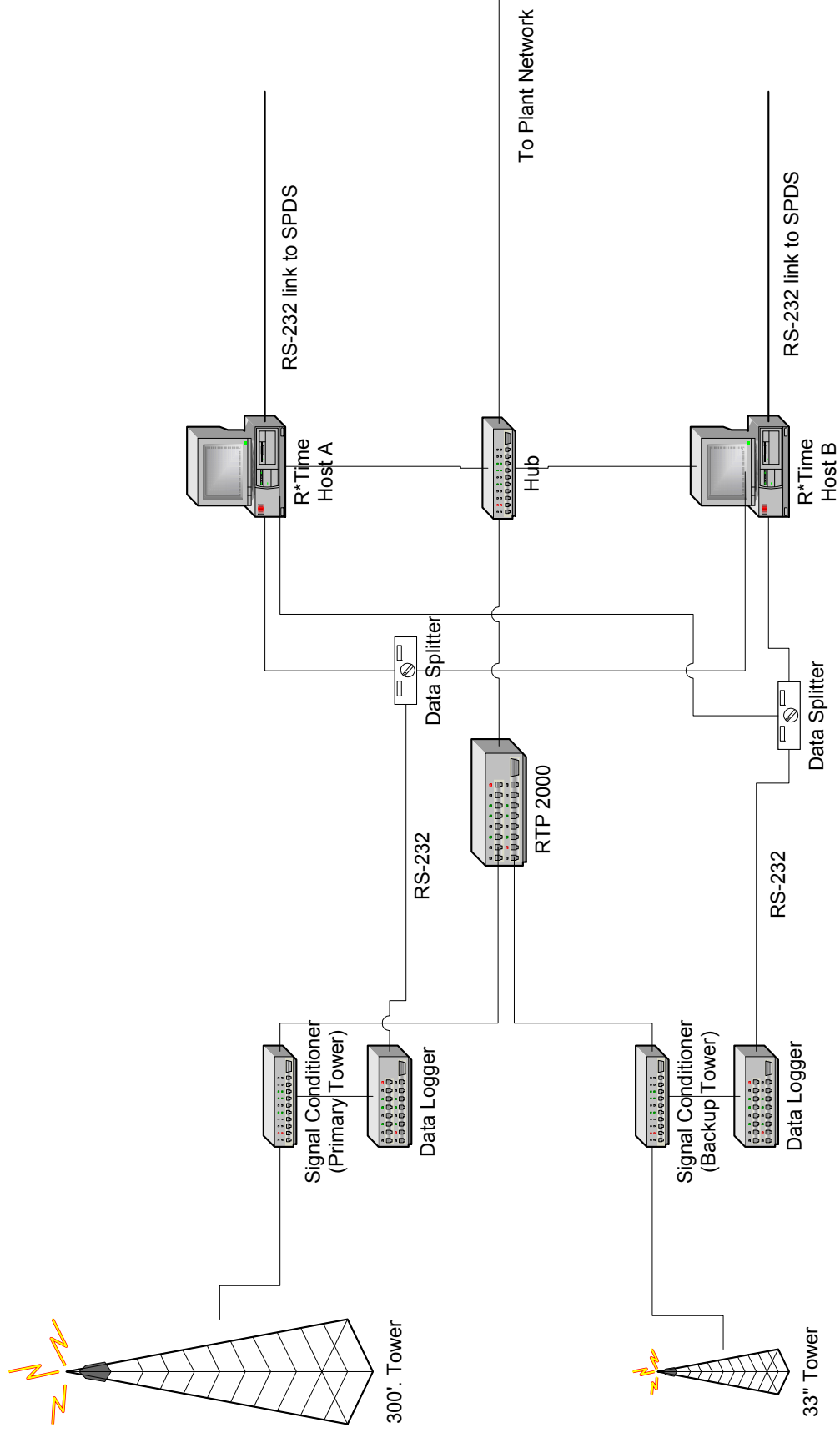
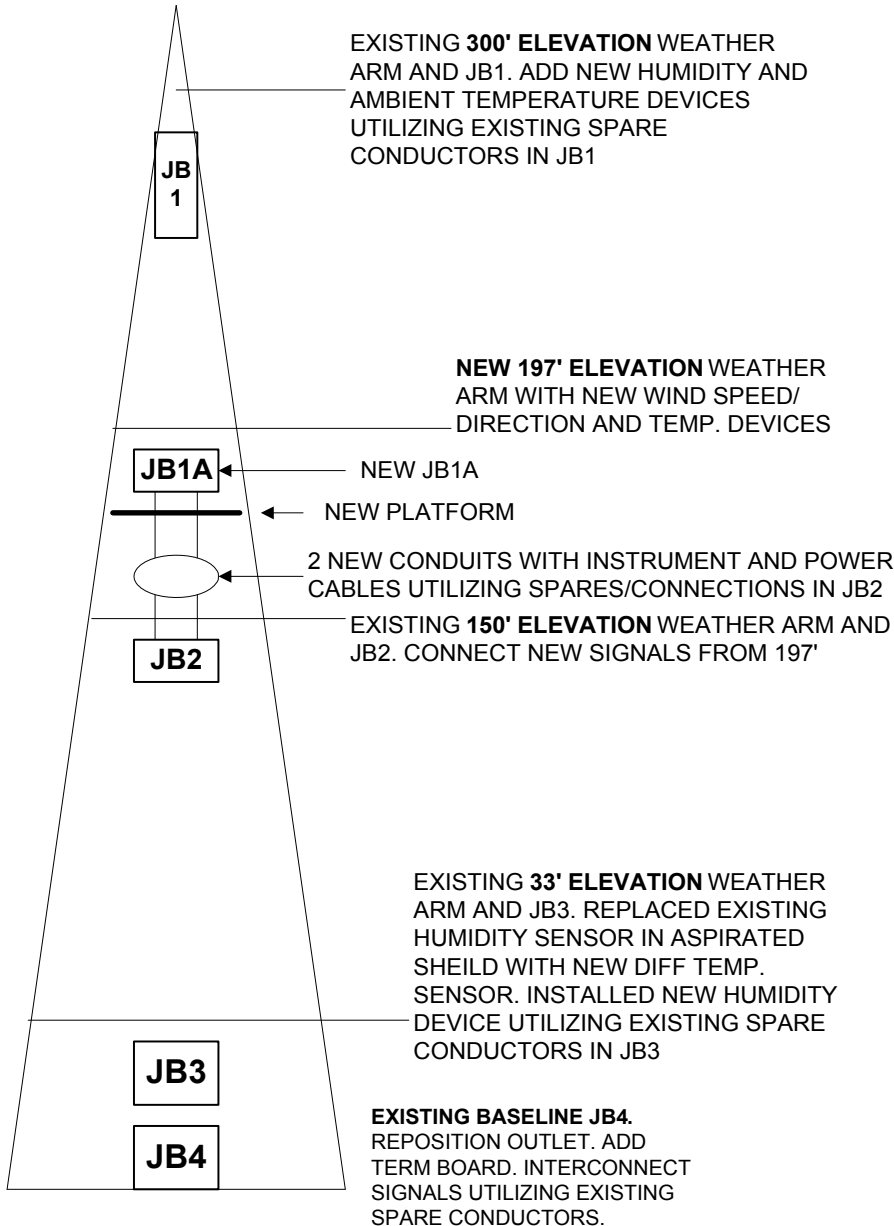

EXHIBIT 3

METEOROLOGICAL TOWER



NOTES:

1. PICTOGRAM IS NOT TO SCALE
2. ALL WEATHER ARMS EXTEND APPROX. 8'-0"
3. NEW JB1A IS 12H x 14W x 6D

REFERENCE DRAWINGS:

- MET TOWER EQUIPMENT DWG. #211019
- MET TOWER TRANSMITTERS DWG. #249635
- MET TOWER ARRANGEMENT DWG. #239850
- MET BUILDING 1PNL14131 DWG. #605799
- DCP 80095184 ADL

**80095184R0
SUP01R0
PICTOGRAM**

MET TOWER
SIMET-1MET

EXHIBIT 4

SUPPORT SYSTEM CONTACTS

| Name/Organization | Function | Telephone Number |
|------------------------------------------------------------------------------------------------------|-----------------------------------------------------------------------|----------------------------------|
| Salem Control Room Shift Manager | Operations | 339-5201/5111 339-5200 |
| Hope Creek Control Room Shift Manager | Operations | 339-3059 339-3027 |
| Healy Company Mike Healy | Maintenance and Calibration Consultant | (717) 548-3786 (717) 548-3035 |
| Meteorological Evaluation Srvs Pat Brennan | Meteorological Consultant (data interrogation and analysis) | (631) 691-3395 |
| ABS Consulting LLC Mark Abrams | MIDAS | (301) 907-9100 |
| Meteorological Instrument Bldg | Support | 339-2596 |
| Hope Creek Chemistry Jenny Shelton | Meteorological Monitoring Program Support:Sensor Cal / Maintenance | 339-1138 |
| Dial-up Data Acquisition Primary DAS Back-up DAS Meteorological data display J. Southers | Meteorological Display & Data Acquisition | 339-5630 |
| Help Desk | Telecomm | 339-5555 |
| Security | Security, Building and Grounds | 339-2222 |
| Scientech | DAS | (860) 563-7572 |
| Emergency Preparedness G. Young | Emergency Preparedness Support | 339-3804 |
| Maintenance Salem WIN | Maintenance Support – CM/PM Workorders | 2390 / 5180 |
| Facilities Maintenance Don Adams | Fill MET diesel | 1040 / 5022 |
| Information Technology J. Southers J. Harris | Computer System Support | 339-5630 339-1519 |
| Supplemental Network/Radio Support Hobart Burnett | IT Services | 339-1728 |
| Salem System Engineering G. Greer | System Engineer | 339-3651 |

| | | |
|---------------------------------------------------|----------------------------------------------------------------------------------------------|--------------|
| Information Technology Netops | Tower Beacon Lights Network Hardware Radio Systems (including alarms) Pager Systems | 339-7008 |
| Information Technology Mark Ferelli | Structural Inspection | 339-5049 |
| IT Corp Tom Chipko | UPS System | 609-799-6900 |
| Salem System Engineering D. Kolasinski | Diesel Generator Technical Issues | 339-2055 |
| Facilities Maintenance D. Barner | Diesel Generator fuel and oil | 339-1601 |
| Salem Mechanical Maintenance D. Brown | Diesel Generator Maintenance | 339-2770 |
| Yard Maintenance Electrical, I&C S. Sheehan | Power, Oversight for Maintenance Vendor- Healy | 339-2389 |
| Hope Creek Design Engineering A. Ghose | Met Structure | 339-2034 |
| Fire Protection FP Duty Supervisor | Fire Protection | 339-2803 |

FORM – 1

Page 1 of 2

TEST EQUIPMENT LIST

TEST EQUIPMENT

| Test Equipment | Id No. | Cal Date |
|----------------------------------|--------|----------|
| Data Precision Model 8100 DC Std | | |
| Psychrometer Model 566 | | |
| Fluke DPC Model 701 | | |

CALIBRATION TOLERANCE

| INSTRUMENT | UNITS | VALUE | Zero – Span ¹ | NOTES |
|-----------------------------|--------------------|------------|--------------------------|-------------------------------------------|
| Wind Direction 300 ft. | Deg. | (+/-) 5 | 358 - 359 | Tolerance on factory certs ² |
| Wind Speed 300 ft. | MPH | (+/-) 0.5 | 0 – 111.8 | Tolerance on factory certs ² |
| Wind Direction 150 ft. | Deg. | (+/-) 5 | 358 - 359 | Tolerance on factory certs ² |
| Wind Speed 150 ft. | MPH | (+/-) 0.5 | 0 – 111.8 | Tolerance on factory certs ² |
| Wind Direction 33 ft. | Deg. | (+/-) 5 | 358 - 359 | Tolerance on factory certs ² |
| Wind Speed 33 ft. | MPH | (+/-) 0.5 | 0 – 111.8 | Tolerance on factory certs ² |
| Wind Direction B/U 33 ft. | Deg. | (+/-) 5 | 358 - 359 | Tolerance on factory certs ² |
| Wind Speed B/U 33 ft. | MPH | (+/-) 0.5 | 0 – 111.8 | Tolerance on factory certs ² |
| Ambient Temperature 33 ft. | Deg C. | (+/-) 0.5 | -50 to +50 | Ice Bath = 0 Deg C |
| Δ Temperature 300 – 33 ft. | Deg C. | (+/-) 0.1 | -5.0 to 10.0 | Ice Bath = 0 Deg C |
| Δ Temperature 150 – 33 ft. | Deg. C. | (+/-) 0.1 | -5.0 to 10.0 | Ice Bath = 0 Deg C |
| EdgeTech Dew Point 33 ft. | Deg. C. | (+/-) 0.5 | -50 to +50 | |
| Pressure | In. Hg | (+/-) 0.1 | 26.0 to 32.0 | |
| Solar Radiation | Lg/cm ² | (+/-) 0.02 | 0 to 2.0 | |
| Relative Humidity 33 ft. | % | (+/-) 4 | 0 to 100 | Range 10% - 100% |
| Precipitation | 1n. | (+/-) 0.01 | 0 to 1 | |
| Ambient Temperature 300 ft. | Deg C. | (+/-) 0.5 | -50 to +50 | Ice Bath = 0 Deg C ³ |
| Relative Humidity 300 ft. | % | (+/-) 4 | 0 to 100 | Range 10% - 100% ³ |
| Wind Direction 197 ft. | Deg. | (+/-) 5 | 358 - 359 | Tolerance on factory certs ^{2,3} |
| Wind Speed 197 ft. | MPH | (+/-) 0.5 | 0 – 111.8 | Tolerance on factory certs ^{2,3} |
| Δ Temperature 197 – 33 ft. | Deg C. | (+/-) 0.1 | -5.0 to 10.0 | Ice Bath = 0 Deg C ³ |
| | | | | |

1. Zero & Span are MetOne Translator Expected Outputs
2. Factory calibration certification provides calibration record (not settable).
3. Sensor values are not transmitted to the Salem or Hope Creek Stations

FORM – 1
Page 2 of 2

TEST EQUIPMENT LIST

VERIFICATION

| Instrument Power Supply | | | |
|-------------------------|-------|---------------------|-------|
| Design +12v +/- 0.5 | | Design -12v +/- 0.5 | |
| Actual | volts | Actual | volts |
| DC | | DC | |

| Wind Sensor Loop Power Supply | |
|-------------------------------|-------|
| Design +15v +/- 0.5 | |
| Actual | volts |
| DC | |

| Barometric Pressure | |
|---------------------|---------|
| Met Tower | M&TE |
| | |
| in. Hg. | in. Hg. |

| Dew Point | |
|-----------|---------------|
| EdgeTech | Psychrometer* |
| | |
| Deg C | Deg C. |

*Calculate from wet bulb reading

Calibration Period From: _____ To: _____ Order No. _____

Performed by: _____ Date: _____

Reviewed by: _____ Date: _____

METEOROLOGICAL TOWER CALIBRATION

| PARAMETER | As Found | | | | As Left | | | | | |
|-------------------------------------|----------|------|----------------------|----------------------|----------|------|------|----------------------|----------------------|----------|
| | ZERO | SPAN | Functional Check N-S | Functional Check E-W | Ice Bath | ZERO | SPAN | Functional Check N-S | Functional Check E-W | Ice Bath |
| Wind Dir 300' | | | | | | | | | | |
| Wind Spd 300' | | | | | | | | | | |
| Wind Dir 150' | | | | | | | | | | |
| Wind Spd 150' | | | | | | | | | | |
| Wind Dir 33' | | | | | | | | | | |
| Wind Spd 33' | | | | | | | | | | |
| Wind Dir BU - 33' | | | | | | | | | | |
| Wind Spd BU - 33' | | | | | | | | | | |
| Temp Amb 33' | | | | | | | | | | |
| Δ T 300'-33' | | | | | | | | | | |
| Δ T 150'-33' | | | | | | | | | | |
| Dew Pt EdgeTech | | | | | | | | | | |
| Barometric Pres | | | | | | | | | | |
| Solar Rad | | | | | | | | | | |
| Relative Humidity 33' | | | | | | | | | | |
| Temp Amb 300' ² | | | | | | | | | | |
| Relative Humidity 300' ² | | | | | | | | | | |
| Wind Dir 197' ² | | | | | | | | | | |
| Wind Spd 197' ² | | | | | | | | | | |
| Δ T 197'-33' ² | | | | | | | | | | |

| Prec. Tip Bkt | Zero | Span | 0.0 | 0.1 | 0.2 | 0.3 | 0.4 | 0.5 | 0.6 | 0.7 | 0.8 | 0.9 | 1.0 |
|-----------------------|------|------|-----|-----|-----|-----|-----|-----|-----|-----|-----|-----|-----|
| As Found ¹ | | | | | | | | | | | | | |
| As Left | | | | | | | | | | | | | |

1. Calibration of tipping Bucket requires only 20 tips (0.2 in).
 2. Sensor values are not transmitted to the Salem or Hope Creek Stations
- Performed By: _____ Date: _____
 Reviewed By: _____ Date: _____

FORM-3
Page 1 of 1
MONTHLY MAINTENANCE CHECK SHEET

LOCATION: Meteorological Tower

Work Order # _____

Digital System

| PARAMETER | AS FOUND ¹ | | AS LEFT ¹ | | REMARKS ² |
|-----------------------------------|-----------------------|------|----------------------|------|----------------------|
| | ZERO | SPAN | ZERO | SPAN | |
| WD 300' | | | | | |
| WS 300' | | | | | |
| WD 150' | | | | | |
| WS 150' | | | | | |
| WD 33' | | | | | |
| WS 33' | | | | | |
| WD BU – 33' | | | | | |
| WS BU – 33' | | | | | |
| Ambient Temp 33' | | | | | |
| ΔT 300'-33' | | | | | |
| ΔT 150'-33' | | | | | |
| EdgeTech Dew Pt | | | | | |
| MetOne Humidity 33' | | | | | |
| Barometric Pressure | | | | | |
| Precipitation Tip Bkt | | | | | |
| Solar Rad | | | | | |
| Ambient Temp 300' ₃ | | | | | |
| WD 197' ³ | | | | | |
| WS 197' ³ | | | | | |
| ΔT 197'-33' ³ | | | | | |
| MetOne Humidity 300' ³ | | | | | |

¹ If data are missing due to equipment malfunction indicate as N/A (not available)

² Instrument tolerances are specified on Form-1

³ Sensor values are not transmitted to the Salem or Hope Creek Stations

Performed by: _____ Date: _____

Reviewed by: _____ Date: _____