

MATERIAL: SB-265 (UNS R56404)
8 REQUIRED

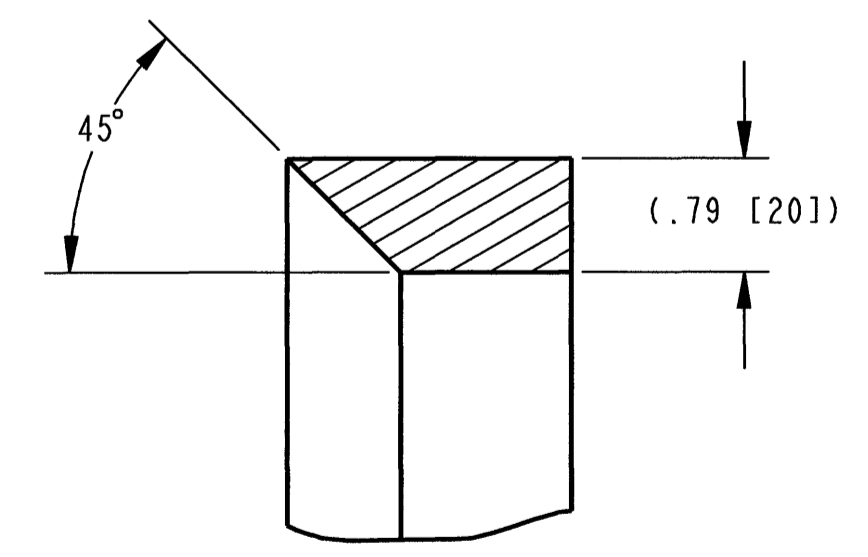

SECTION S-S
SCALE 3/4

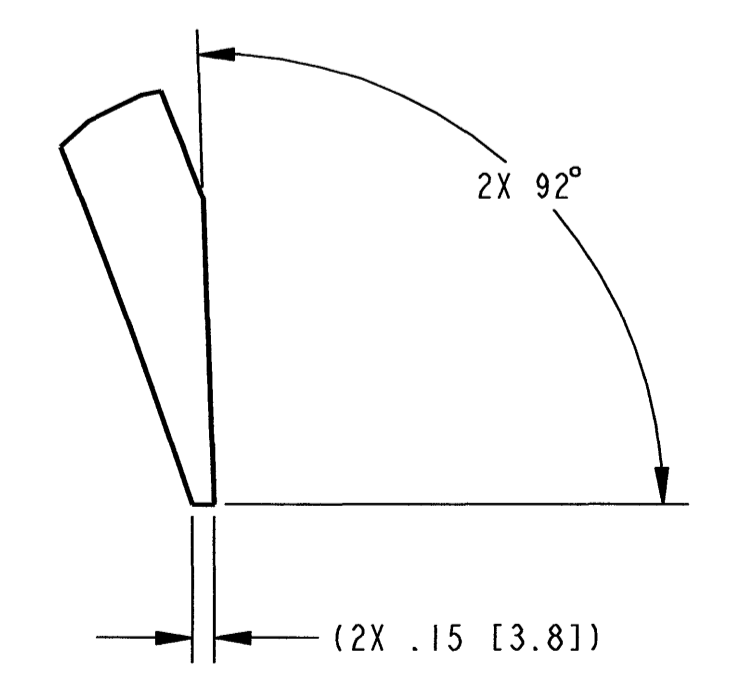

DETAIL A
SCALE 3/4

THIS DRAWING IS PRELIMINARY AND NOT INTENDED FOR CONSTRUCTION, PROCUREMENT OR FABRICATION.

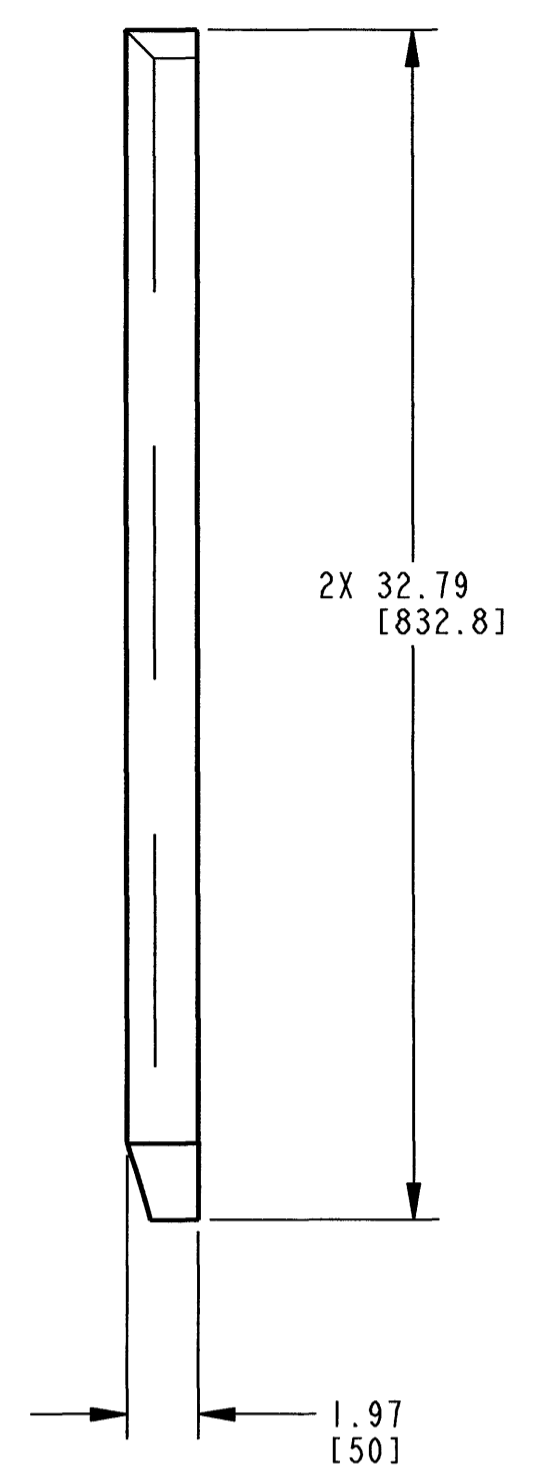

NOTES:

1. ALL DIMENSIONS ARE IN INCHES MILLIMETERS ARE IN BRACKETS.
2. ALL DIMENSIONS ARE REFERENCE ONLY.
3. DO NOT SCALE FROM DRAWING.
4. THE DRIP SHIELD IS CLASSIFIED AS IMPORTANT TO WASTE ISOLATION (ITWI).

DESIGN INPUT REFERENCE LIST

BASIS OF DESIGN FOR THE TAD CANISTER-BASED REPOSITORY DESIGN CONCEPT 000-3DR-MGR0-00300-000-000.

REFERENCE DRAWINGS

- 000-M00-SSE0-00101-000 INTERLOCKING DRIP SHIELD CONFIGURATION
- 000-M00-SSE0-00102-000 INTERLOCKING DRIP SHIELD CONFIGURATION
- 000-M00-SSE0-00103-000 INTERLOCKING DRIP SHIELD CONFIGURATION

00B	EXTENSIVE REVISION - CHANGED MATERIAL FROM SB-265 (UNS R56405) TO SB-265 (UNS R56404) PER TMRB-2006-004. UPDATED DIMENSIONS TO CONFORM WITH CURRENT DRAFTING STANDARDS. REMOVED EXTRA DIMENSIONS. REVISED NOTE 4. ADDED DESIGN INPUT REFERENCE LIST. ADDED REFERENCE DRAWINGS.	4/29/07																			
00A	INITIAL ISSUE	3/3/04	ZC	TD	AS	CC	N/A														
REV	DESCRIPTION	DATE	ORG	CHK	EGS	FE	DEM	OE													
REVISION HISTORY																					
ORIGINATOR	Z. CEYLAN	INITIAL/DATE	ZC 3/3/04	U.S. DEPARTMENT OF ENERGY Office of Civilian Radioactive Waste Management Management and Operation of the Office of SAIC Civilian Radioactive Waste Management Program																	
CHECKER	T. DEBUES	TD 3/3/04																			
ENGINEERING GROUP SUPERVISOR	A. SCHEIDER	AS 3/3/04																			
PROJECT ENGINEER	C. CHAGNON	CC 3/3/04																			
DISCIPLINE ENGINEERING MANAGER	N/A	N/A																			
QA CONCURRENCE	J. HEANEY	JH 3/3/04																			
SAFETY CLASSIFICATION		AS NOTED		DOCUMENT IDENTIFIER: 000-M00-SSE0-01601-000																	
SIZE		D		CAD FILE: 000-M00-SSE0-01601-000.DRW																	
SCALE		NONE		REV: 00B																	

CASE CODE:

RECORD DESIGNATOR QA:QA