

---

---

# Assessment of the NRC Enforcement Program

---

---

**U.S. Nuclear Regulatory Commission**

**Review Team Report**



## AVAILABILITY NOTICE

### Availability of Reference Materials Cited in NRC Publications

Most documents cited in NRC publications will be available from one of the following sources:

1. The NRC Public Document Room, 2120 L Street, NW., Lower Level, Washington, DC 20555-0001
2. The Superintendent of Documents, U.S. Government Printing Office, P. O. Box 37082, Washington, DC 20402-9328
3. The National Technical Information Service, Springfield, VA 22161-0002

Although the listing that follows represents the majority of documents cited in NRC publications, it is not intended to be exhaustive.

Referenced documents available for inspection and copying for a fee from the NRC Public Document Room include NRC correspondence and internal NRC memoranda; NRC bulletins, circulars, information notices, inspection and investigation notices; licensee event reports; vendor reports and correspondence; Commission papers; and applicant and licensee documents and correspondence.

The following documents in the NUREG series are available for purchase from the Government Printing Office: formal NRC staff and contractor reports, NRC-sponsored conference proceedings, international agreement reports, grantee reports, and NRC booklets and brochures. Also available are regulatory guides, NRC regulations in the *Code of Federal Regulations*, and *Nuclear Regulatory Commission Issuances*.

Documents available from the National Technical Information Service include NUREG-series reports and technical reports prepared by other Federal agencies and reports prepared by the Atomic Energy Commission, forerunner agency to the Nuclear Regulatory Commission.

Documents available from public and special technical libraries include all open literature items, such as books, journal articles, and transactions. *Federal Register* notices, Federal and State legislation, and congressional reports can usually be obtained from these libraries.

Documents such as theses, dissertations, foreign reports and translations, and non-NRC conference proceedings are available for purchase from the organization sponsoring the publication cited.

Single copies of NRC draft reports are available free, to the extent of supply, upon written request to the Office of Administration, Distribution and Mail Services Section, U.S. Nuclear Regulatory Commission, Washington, DC 20555-0001.

Copies of industry codes and standards used in a substantive manner in the NRC regulatory process are maintained at the NRC Library, Two White Flint North, 11545 Rockville Pike, Rockville, MD 20852-2738, for use by the public. Codes and standards are usually copyrighted and may be purchased from the originating organization or, if they are American National Standards, from the American National Standards Institute, 1430 Broadway, New York, NY 10018-3308.

---

---

# Assessment of the NRC Enforcement Program

---

---

Manuscript Completed: April 1995  
Date Published: April 1995

**Team Leader:**  
James Lieberman, Director, Office of Enforcement

**Team Members:**  
E. William Brach, Deputy Director, Division of Industrial  
and Medical Nuclear Safety, NMSS  
James A. Fitzgerald, Former Acting Director, Office of Investigations  
Luis A. Reyes, Deputy Regional Administrator, Region II  
Roy P. Zimmerman, Associate Director for Projects, NRR

**Legal Advisor:**  
Jack R. Goldberg, Deputy Assistant General Counsel for Enforcement

**U. S. Nuclear Regulatory Commission  
Washington, DC 20555-0001**



1. The first part of the document discusses the importance of maintaining accurate records of all transactions and activities. It emphasizes that this is essential for ensuring transparency and accountability in the organization's operations.

2. The second part of the document outlines the various methods and tools used to collect and analyze data. It highlights the need for consistent data collection procedures and the use of advanced analytical techniques to derive meaningful insights from the data.

3. The third part of the document focuses on the implementation of data-driven decision-making processes. It discusses how the collected data is used to identify trends, assess risks, and make strategic decisions that align with the organization's goals and objectives.

4. The fourth part of the document addresses the challenges and risks associated with data management and analysis. It provides strategies to mitigate these risks, such as ensuring data security, maintaining data integrity, and addressing privacy concerns.

5. The fifth part of the document concludes by summarizing the key findings and recommendations. It emphasizes the ongoing nature of data management and the importance of continuous monitoring and improvement of the data-driven processes.

6. The final part of the document provides a list of references and resources used in the research and analysis. It includes books, articles, and online resources that provide further information on the topics discussed in the document.



### *Abstract*

On May 13, 1994, the Nuclear Regulatory Commission's (NRC's) Executive Director for Operations established a review team to assess the NRC enforcement program. The team evaluated the current system, and solicited comments from various NRC offices, other Federal agencies, members of industry, and the public. This report presents the team's assessment.

The report summarizes current processes and suggests certain changes. It proposes: (1) increased clarity, focus, and simplicity in the enforcement program; (2) retention of four severity levels of violations, with a clear focus on safety; (3) holding enforcement conferences only when needed, clarifying their status as predecisional, and making open conferences the norm; (4) a streamlined civil penalty assessment process, with fewer decisional points and limited outcomes, and the use of discretion where appropriate; and (5) implementation changes to increase efficiency. Recommendations are given in each area.



## *Contents*

Acknowledgements .....	viii
Abbreviations .....	ix
Executive Summary .....	ES-1

### *Part I: Introduction*

<i>Section I.A: Background and Definitions</i> .....	I.A-1
<i>Section I.B: Review Team Methods</i> .....	I.B-1
<i>Section I.C: Overview of Current NRC Enforcement Program</i> .....	I.C-1
1. Severity Levels .....	I.C-1
2. Enforcement Conferences .....	I.C-2
3. Enforcement Actions .....	1.C-2
4. Notices of Violation .....	1.C-2
5. Civil Penalties .....	1.C-3
6. Orders and Confirmatory Action Letters .....	1.C-4
7. Discretion .....	1.C-4
8. Enforcement Data .....	1.C-5

### *Part II. Discussion of Issues*

<i>Section II.A: Purpose and Objectives of the NRC Enforcement Program</i> .....	II.A-1
1. Appropriateness of the Stated Purpose and Objectives .....	II.A-1
2. Achieving a Balance Between Punishment and Incentives .....	II.A-5
3. Effectiveness of Sanctions .....	II.A-9
4. Clarity of the Regulatory Message .....	II.A-10
5. Consistency and Predictability .....	II.A-13
6. The Effect of Publicity .....	II.A-14
7. Considering Different Policies for Different Types of Licensees .....	II.A-16
Recommendations .....	II.A-18
<i>Section II.B: Severity Level and Notices of Violation</i> .....	II.B-1
1. Comments .....	II.B-1
2. Violation Significance .....	II.B-2

---

3. Review of Severity Level Examples . . . . .	II.B-3
4. Severity Level IV and V Violations . . . . .	II.B-4
5. Non-Cited Violations (NCVs) . . . . .	II.B-6
Recommendations . . . . .	II.B-8
<b>Section II.C: Enforcement Conferences</b> . . . . .	II.C-1
1. Purpose and Use . . . . .	II.C-1
2. Open Enforcement Conferences . . . . .	II.C-7
Recommendations . . . . .	II.C-21
<b>Section II.D: Civil Penalties</b> . . . . .	II.D-1
1. Background and Summary of Comments . . . . .	II.D-1
2. Purpose and Philosophy of Civil Penalties . . . . .	II.D-3
3. Increasing Civil Penalty Amounts . . . . .	II.D-11
4. Application of Individual CP Adjustment Factors . . . . .	II.D-16
5. Interrelatedness of CP Adjustment Factors . . . . .	II.D-22
6. Proposed CP Assessment Strategy . . . . .	II.D-25
7. Other CP-Related Considerations . . . . .	II.D-38
Recommendations . . . . .	II.D-40
<b>Section II.E: Other Sanctions</b> . . . . .	II.E-1
1. Background and Summary of Comments . . . . .	II.E-1
2. Discussion . . . . .	II.E-1
Recommendations . . . . .	II.E-1
<b>Section II.F: Violations Involving Willfulness and Individual Wrongdoing</b> . . . . .	II.F-1
1. Background and Summary of Comments . . . . .	II.F-1
2. Discussion . . . . .	II.F-2
Recommendations . . . . .	II.F-4
<b>Section II.G: Implementation, Delegation, and Oversight</b> . . . . .	II.G-1
1. Staff Oversight . . . . .	II.G-1
2. Dissemination of Significant Enforcement Actions . . . . .	II.G-3
3. Commission Consultation . . . . .	II.G-4
4. Placement of the Enforcement Policy in the Code of Federal Regulations . . . . .	II.G-8

5. Timeliness of Enforcement Actions ..... II.G-9  
    Recommendations ..... II.G-10

**Part III: Summary and Recommendations**

**Section III.A: Conclusions** ..... III.A-1

**Section III.B: Consolidated List of Recommendations**

1. Recommendations to the Commission ..... III.B-1  
2. Recommendations to the Staff ..... III.B-4

Appendix A: Review Team Charter

Appendix B: *Federal Register* Notices, August and September 1994

Appendix C: Legislative History of NRC Civil Penalty Authority

Appendix D: History of the Enforcement Policy

Appendix E: Enforcement Data

Appendix F: Background on Open Conferences

Appendix G: Examples of Applying the Identification Assessment Factor

## ***Acknowledgements***

The Review Team offers its sincere appreciation to Laban L. Coblentz for his assistance in the coordination of this effort and preparation of this report. In addition, the Review Team expresses its appreciation to the following NRC staff members who assisted in this effort:

Dawn R. Burrier	Stephen H. Lewis	Egan Y. Wang
Catherine T. Haney	Renée M. Pedersen	Louis L. Wheeler
William D. Hutchison	Betty T. Summers	

Finally, the Review Team appreciates the cooperation shown by the regions, the program offices, and other Federal agencies during this review.

---

---

## *Abbreviations*

AEA	Atomic Energy Act
AEC	Atomic Energy Commission
AIT	Augmented Inspection Team
APA	Administrative Procedure Act
CAL	Confirmatory Action Letter
CFR	<i>Code of Federal Regulations</i>
CP	Civil Penalty
DEDO	Deputy Executive Director for Operations
DFI	Demand for Information
EC	Enforcement Conference
EDO	Executive Director for Operations
EGM	Enforcement Guidance Memorandum
EN	Enforcement Notification
EPA	Environmental Protection Agency
FAA	Federal Aviation Administration
FCC	Federal Communications Commission
FR	<i>Federal Register</i>
GAO	General Accounting Office
GL	Generic Letter
IG	Inspector General
INPO	Institute of Nuclear Power Operations
IPE	Individual Plant Examination
LOR	Letter of Reprimand
NCV	Non-Cited Violation
NMSS	Office of Nuclear Material Safety and Safeguards
NOED	Notice of Enforcement Discretion
NOV	Notice of Violation
NRC	Nuclear Regulatory Commission
NRR	Office of Nuclear Reactor Regulation
OE	Office of Enforcement
OGC	Office of the General Counsel
OI	Office of Investigations
OPA	Office of Public Affairs
PDR	Public Document Room
PRA	Probabilistic Risk Assessment
SALP	Systematic Assessment of Licensee Performance
SL	Severity Level
SRM	Staff Requirements Memorandum

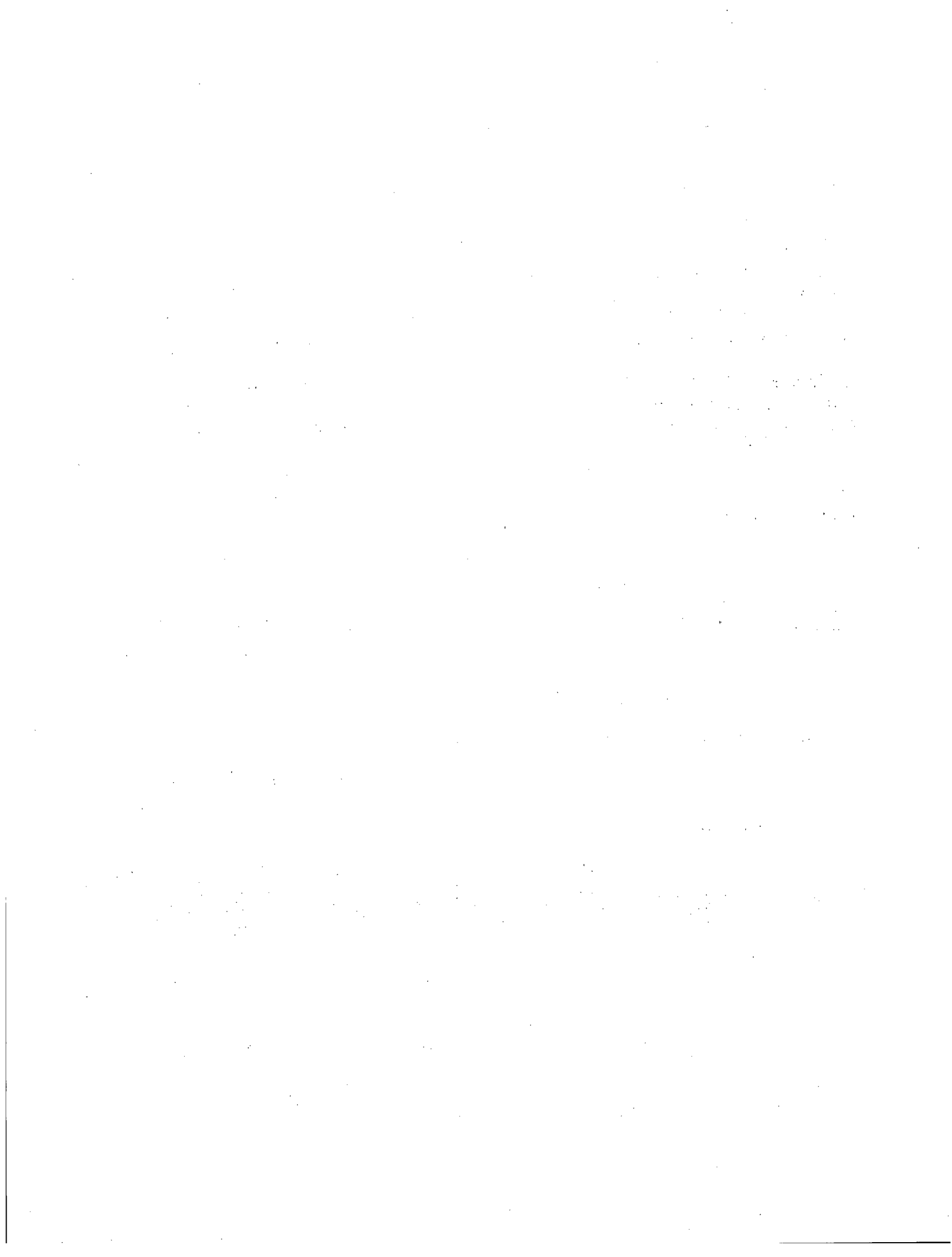



## *Executive Summary*

On May 13, 1994, the Executive Director for Operations established a review team to assess the NRC enforcement program (hereafter referred to as "Review Team" or "Team"). A copy of the Review Team's charter is enclosed as Appendix A. The charter asked the Review Team to consider: (1) whether the defined purposes of the program are appropriate; and (2) whether the NRC's enforcement practices and procedures are consistent with those purposes.

As directed by the charter, the Team approached these questions from several perspectives, reviewing the evolution of the current enforcement program and considering the views of the NRC staff, other Federal agencies, licensees and other industry representatives, and concerned members of the public. Meetings were held with each of the NRC regions, NRC program offices, and various Federal agencies. Relevant documents were reviewed, including applicable statutes and regulations, NRC policies and procedures, previous assessments, responses to requests for comment in the *Federal Register*, and policies of other agencies.

Under the Atomic Energy Act, the Commission is given authority to take appropriate enforcement action for violations of Commission requirements. The NRC's enforcement program is guided by the Commission's "General Statement of Policy and Procedure for NRC Enforcement Actions" (hereafter referred to as "Enforcement Policy" or "Policy"), as promulgated in 10 CFR Part 2, Appendix C. More detailed procedures for staff implementation of the Policy are given in the *NRC Enforcement Manual*.

### *1. General Assessment of the Current Program*

The Review Team concludes that the existing NRC enforcement program, as implemented, is appropriately directed toward supporting the agency's overall safety mission. This conclusion is reflected in several aspects of the program:

- ◆ The Policy recognizes that violations have differing degrees of safety significance. As reflected in the severity levels, safety significance includes actual safety consequence, potential safety consequence, and regulatory significance. The use of graduated sanctions, from Notices of Violation to orders, further reflects the varying seriousness of noncompliances.
- ◆ The enforcement conference is an important step in achieving a mutual understanding of facts and issues before making significant enforcement decisions. While these conferences take time and effort for both the NRC and licensees, they generally

contribute to better decision-making.

- ◆ Enforcement actions deliver regulatory messages properly focused on safety. These messages emphasize the need for licensees to identify and correct violations, to address the root causes, and to be responsive to initial opportunities to identify and prevent violations.
- ◆ The use of discretion and judgment throughout the deliberative process recognizes that enforcement of NRC requirements does not lend itself to mechanistic treatment.

The Review Team also finds, however, that the existing program at times provided mixed regulatory messages to the licensees, and room for improvement existed in both the Enforcement Policy and implementation. The Team believes that the overall program focus should be clarified as follows:

- ◆ Emphasize the importance of identifying problems before events occur, and of taking prompt, comprehensive corrective action when problems are identified;
- ◆ Direct agency attention at licensees with multiple enforcement actions in a relatively short period; and
- ◆ Focus on current performance of licensees.

In addition, the Team believes the process can be simplified to improve the predictability of decision-making and obtain better consistency among regions. Implementation improvements can improve timeliness and increase the efficiency of the deliberative process without adversely affecting either the effectiveness or consistency of the overall program.

## ***2. Significant Observations and Recommendations***

The scope of the Team's review included the entire range of NRC enforcement actions. However, few substantive proposals were made related to orders, Confirmatory Action Letters, violations involving willfulness and individual wrongdoing, or timeliness of enforcement actions. Substantial recommendations were primarily focused on the areas of enforcement philosophy, Notices of Violation, civil penalties, and enforcement conferences.

### ***a. Purpose of the Enforcement Program***

The purpose of the NRC enforcement program should be clarified. The program

should supplement the NRC's overall safety mission in protecting the public, workers, and the environment. Consistent with that purpose, enforcement actions should be used to create deterrence by: (1) emphasizing the importance of compliance with requirements, and (2) encouraging prompt identification and prompt, comprehensive correction of violations.

***b. Use of Graduated Enforcement Sanctions***

The NRC should continue to use a graduated system of enforcement actions, in a manner that reflects the varying safety significance of different violations, and that can be adjusted based on the circumstances of the violation.

The NRC's enforcement efforts should be focused most on matters of greatest safety significance. In the broadest sense, this focus should be directed at Severity Level (SL) I and II violations, licensees with multiple SL III problems, and willful violations.

SL V violations should be eliminated. Formal enforcement actions should only be taken for violations categorized at SL I to IV, to better focus the inspection and enforcement process on safety. Minor violations, if documented, should be treated as Non-Cited Violations.

***c. Increased Clarity***

The Enforcement Policy should be designed to convey clear regulatory messages, and should attempt to minimize the number and complexity of decision points. The Policy should be simplified to ensure, where possible, a consistent and predictable result. While the need remains for judgment and discretion, this change should reinforce the overall objectives of the enforcement program and highlight the actions expected of licensees in order to avoid civil penalties (i.e., identifying and correcting violations before events occur).

***d. Enforcement Conferences***

To emphasize their status as part of the deliberative process, enforcement conferences should be renamed "predecisional enforcement conferences." These conferences should be considered when the agency reasonably expects that an escalated enforcement action will result, and held when additional information is needed to make an enforcement

decision. They should also normally be held if requested by a licensee.

Predecisional enforcement conferences should normally be public meetings held in regional offices. The intent of open conferences is not to maximize public attendance, but rather to provide the public with an opportunity to observe the regulatory process. Conferences should be announced in a manner consistent with other NRC open meetings. Press releases should not normally be used.

*e. Civil Penalties: General Philosophy*

Applied with discretion and judgment, civil penalties (CPs) can provide an additional effective deterrent against future violations, by: (1) emphasizing the importance of adherence to requirements; and (2) reinforcing those aspects of licensee performance that are especially crucial in ensuring quality (e.g., self-identification of problems and root causes, prompt and comprehensive correction of errors, and recognition and avoidance of adverse trends).

With limited exceptions, maintaining the existing base CP amounts should result in meaningful civil penalties, and should allow meaningful differentiation among violations of varying significance. In addition, increasing the incentives for strong self-monitoring and corrective action programs could be better accomplished by revising the overall CP assessment process, as discussed below, than by raising the base CP amounts.

*f. Civil Penalties: Proposed Assessment Process*

The flowchart given below is a graphic representation of the proposed CP assessment process. Once a violation has been determined to be SL III or above, the CP assessment process should consist, at most, of four basic decisional points: (1) whether the licensee has had a previous escalated enforcement action during the past 2 years or past 2 inspections, whichever is longer; (2) whether the licensee should be given credit for actions related to identification; (3) whether the licensee's corrective actions may reasonably be considered prompt and comprehensive; and (4) whether, in view of all the circumstances, the case in question requires the exercise of discretion. While each of these decisional points may have several associated considerations for any given case, the outcome of that case, absent the exercise of discretion, should be limited to three outcomes: no CP, a base CP, or a base CP +100%.

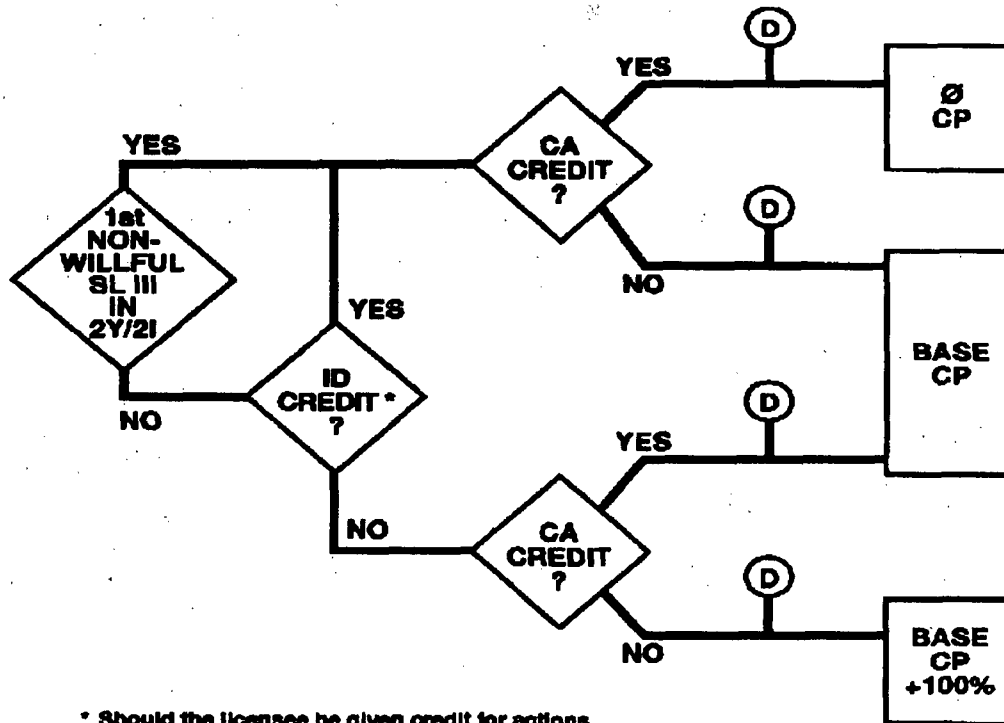

\* Should the licensee be given credit for actions related to identification?

**(D)** Discretion, e.g., SL I and II violations should normally result in a civil penalty regardless of ID and CA.

**(1) Initial Escalated Action**

When the NRC determines that a non-willful SL III violation has occurred, and the licensee has not had a previous escalated action during the past 2 years or 2 inspections, the only consideration should be whether the licensee's corrective action for the present violation may reasonably be considered prompt and comprehensive (see discussion under (3), below).

If the corrective action is judged to be prompt and comprehensive, the Notice of Violation should be issued with no associated CP. If the corrective action is judged to be less than prompt and comprehensive, the Notice of Violation should be issued with a base CP.

## **(2) Credit for Actions Related to Identification**

If an SL I or II violation or a willful SL III violation has occurred--or if, during the past 2 years or 2 inspections, the licensee has been issued at least one other escalated action--additional factors should be considered in the CP assessment. The first of these is whether the licensee should be given credit for actions related to identification. This decision requires considering who identified the problem, whether the problem resulted in an event, the ease of discovery, the degree of licensee initiative shown, whether prior opportunities existed to identify the problem, and other similar factors. The following general guidance is provided:

- ◆ When a problem requiring corrective action is licensee-identified (i.e., identified before the problem has resulted in an event), the NRC should normally give the licensee credit for actions related to identification, regardless of whether prior opportunities existed to identify the problem.
- ◆ When a problem requiring corrective action is identified through an event, the decision on whether to give the licensee credit for actions related to identification should consider the ease of discovery, whether the event occurred as the result of a licensee self-monitoring effort (i.e., whether the licensee was "looking for the problem"), the degree of licensee initiative in identifying the problem or problems requiring corrective action, and whether prior opportunities existed to identify the problem. Any of these considerations may be overriding if particularly noteworthy or particularly egregious.
- ◆ When a problem requiring corrective action is NRC-identified, the decision on identification credit should be based on whether the licensee should reasonably have identified the problem (and taken action) earlier.
- ◆ For "mixed" identification situations (i.e., where multiple violations exist, some NRC-identified, some licensee-identified), the NRC's evaluation should determine whether the licensee could reasonably have been expected to identify the violation in the NRC's absence.

When the NRC determines that the licensee should receive credit for actions related to identification, the CP assessment should normally result in either no CP or a base CP, based on whether corrective action is judged to be reasonably prompt and comprehensive. When the licensee is not given credit for actions related to identification, the same judgment on corrective action should normally

result in either a base CP or a base CP +100%.

**(3) *Credit for Prompt and Comprehensive Corrective Action***

This factor encourages licensees to (1) take the immediate actions necessary upon discovery of a violation that will restore safety and compliance with the requirement; and (2) develop and implement (in a timely manner) the lasting actions that will not only prevent recurrence of the violation at issue, but will be appropriately comprehensive, given the significance and complexity of the violation, to prevent occurrence of violations with similar root causes.

In assessing this factor, consideration will be given to the timeliness of the corrective action, the adequacy of the licensee's root cause analysis, and, given the significance and complexity of the issue, the comprehensiveness of the corrective action (i.e., whether the action is focused narrowly to the specific violation or broadly to the general area of concern). Even in cases where the NRC, at the time of the predecisional enforcement conference, identifies additional peripheral or minor corrective action still to be taken, the licensee may be given credit in this area, as long as the licensee's actions addressed the underlying root cause and are considered sufficient to prevent recurrence of the violation and similar violations.

**(4) *Exercise of Discretion***

The ability to exercise discretion (in tailoring sanctions to the circumstances of each case) must be preserved. The recommended approach provides for the use of discretion to deviate from the normal approach where necessary to ensure that the sanction reflects the significance of the circumstances and conveys the appropriate regulatory message.

**g. *Implementation***

In implementing the Enforcement Policy, the need for agency-wide consistency should be balanced against the resource cost of implementing the program. While no changes are recommended to existing delegation practices, the streamlined approach will give more responsibility to the regions while maintaining Headquarters oversight. The Team recommends an approach that focuses the Office of Enforcement review on enforcement strategy, severity levels, violations, and enforcement policy rather than on the actual correspondence. The Team also recommends more staff flexibility in deciding which cases require consultation with the Commission. These changes should provide the necessary oversight to achieve a relatively consistent enforcement program

while obtaining the benefits of a streamlined approach. They should also result in decreasing the time to process cases.

Finally, to reinforce the longstanding Commission position that the Enforcement Policy is a statement of general application rather than a binding regulation, the Enforcement Policy should be removed from the Code of Federal Regulations.

### 3. *Conclusion*

The Review Team believes that these recommendations should produce an enforcement program with clearer regulatory focus and more predictability. The Review Team expects that these recommendations should increase the public health and safety by better emphasizing the prevention, detection, and correction of violations before events occur with impact on the public.



## *Part I: Introduction*



*Section I.A: Background and Definitions*

On May 13, 1994, the Executive Director for Operations (EDO) established a Review Team composed of senior NRC managers to reexamine the NRC enforcement program. A copy of the Review Team's charter is enclosed as Appendix A.

The purposes of this review effort are: (1) to perform an assessment of the NRC's enforcement program to determine whether the defined purposes of the enforcement program are appropriate; (2) to determine whether the NRC's enforcement practices and procedures for issuing enforcement actions are consistent with those purposes; and (3) to provide recommendations on any changes the Review Team believes advisable. The Review Team initially was to complete its review and issue its report, including recommendations, by the end of January 1995. This date was extended to March 31, 1995 after discussions with the EDO.

In accordance with its charter, the Review Team considered the following principal issues in conducting its assessment of the enforcement program:

- ◆ The balance between providing deterrence and incentives (both positive and negative) for the identification and correction of violations;
- ◆ The appropriateness of NRC sanctions;
- ◆ Whether the Commission should seek statutory authority to increase the amount of civil penalties;<sup>1</sup>
- ◆ Whether the NRC should use different enforcement policies and practices for different licensees (e.g., materials licensees in contrast to power reactors or large fuel facilities); and
- ◆ Whether the Commission should establish open enforcement conferences as the normal practice.<sup>2</sup>

---

<sup>1</sup>In 1993, the Commission conducted a reassessment of the NRC's program for protecting allegers against retaliation. That Review Team recommended, among other things, that the NRC should seek an amendment to Section 234 of the Atomic Energy Act of 1954 to increase the current maximum civil penalty from \$100,000 per violation per day to \$500,000 per violation per day, to be normally used for willful violations (see NUREG-1499, January 7, 1994, p. II.D-5). Additional discussion of this recommendation is given in Section II.D of this report. The Commission did not act on this recommendation, but instead approved a staff proposal to defer action on the recommendation pending this review.

<sup>2</sup>In 1992, the NRC established a two-year trial program for making enforcement conferences open to attendance by members of the public (57 FR 30762, July 10, 1992). This trial program was to end July 11, 1994, upon which date comments were due on whether NRC should routinely conduct open enforcement conferences. However, in light of the current broad-scope

As part of its assessment, the Review Team also considered the degree of staff effort required to implement the existing program.

Part II of this report discusses each of these areas in detail. To place these discussions in context, Section I.B gives a summary of the Review Team's methods, and Section I.C gives an overview of the existing NRC enforcement program.

The following list clarifies, for the purposes of this report, certain relevant terms and concepts:

- ◆ **Commenter:** refers to any individual or group who responded to the Review Team's requests for comment. Commenters included licensees, contractors, industry representatives, NRC management and staff, and members of the public. Comments were received in a variety of forums, both orally and in writing.
- ◆ **Deterrence:** in the context of enforcement, refers to the effect of discouraging future non-compliance. The concept of deterrence is discussed more fully in Section II.A.1.c.
- ◆ **Escalated Enforcement Action:** (or "escalated action") refers to an enforcement action in one of the following categories: (1) a Notice of Violation for an SL I, II, or III violation; (2) a CP, regardless of severity level; or (3) an order based on a violation.
- ◆ **Licensee:** as used in this report, should be taken to include licensees, vendors, certificate holders, and other persons subject to NRC enforcement jurisdiction. The Enforcement Policy primarily addresses the activities of NRC licensees; therefore, the term "licensee" is used throughout this report. However, in cases where the NRC finds it appropriate to take enforcement action against a non-licensee or individual, the applicable guidance in the Policy is used.
- ◆ **Missed Opportunity:** refers to a licensee's failure to take advantage of an opportunity to identify a problem and take corrective action. This concept is also referred to as "prior opportunity" or "prior opportunity to identify."
- ◆ **Requirement:** a legally binding requirement such as a statute, regulation, license condition (including technical specifications), or order.

---

assessment of the enforcement program, the trial program was extended pending the outcome of this review (59 FR 36796, July 19, 1994). In addition to the larger review of the enforcement program, this report analyzes the trial program on open enforcement conferences.

---

---

*Section I.B: Review Team Methods*

The Review Team issued two *Federal Register* notices to solicit comments on a variety of issues associated with its charter. Copies of these notices are given as Appendix B. The first notice, published August 23, 1994 (59 *FR* 43298), addressed a wide range of issues associated with NRC enforcement philosophy, policy and practice. The second notice, published September 27, 1994 (59 *FR* 49215), addressed the use of Notices of Enforcement Discretion (NOEDs) under Section VII.C of the Enforcement Policy. Copies of both notices were sent to several thousand licensees and interested members of the public. About 60 responses were received, providing many thoughtful insights that proved to be of use to the Team.

The Team met with each of the NRC Commissioners, the Office Directors of NRR, NMSS, and AEOD, the Regional Administrators, the Director of Public Affairs, other agency representatives, and representatives from several Agreement State programs. Written comments were solicited from the regions and program offices. The Team also sought views from various Federal agencies and met with senior representatives from the Federal Aviation Administration (FAA) and the Environmental Protection Agency (EPA).

In addition to the public comments received, the Team considered the following documents as background material:

- ◆ Past NRC and Atomic Energy Commission (AEC) Enforcement Policies and revisions
- ◆ Enforcement policies of other Federal agencies (including EPA, Department of Energy (DOE), and FAA)
- ◆ Enforcement policies of a number of Agreement States
- ◆ Law review articles addressing enforcement philosophy
- ◆ The 1979 Administrative Conference of the United States, Recommendation 79-3, "Agency Assessment of Civil Monetary Penalties" (July 23, 1979)
- ◆ The "Report of the Advisory Committee for Review of the Enforcement Policy" (November 22, 1985)
- ◆ The August 1989 "Review of NRC's Enforcement Program," conducted by the NRC Inspector General
- ◆ The 1992 "Assessment of the Reactor Inspection Program" (OPP-92-01), performed by the NRC Office of Policy Planning
- ◆ Nuclear Regulatory Review Study, prepared for the Nuclear Energy Institute by Towers Perrin (October 24, 1994)
- ◆ Comments received in response to the *Federal Register* notice on open enforcement conferences (see Appendix F)

The September 1994 *Federal Register* notice reflected the Team's intention, at that time, to

review the agency's NOED practices. This intention was later revised to avoid duplicating the efforts of a separate staff evaluation on NOED use. Specifically, prior to the *Federal Register* notice, an NOED review group was established to evaluate the staff's implementation of the existing NOED policy, and recommend changes to the policy if appropriate. The group issued its conclusions and recommendations on September 12, 1994, in its report entitled "Notice of Enforcement Discretion Review Team Report." The NRC staff then considered the review group's recommendation, the October 1, 1994 report of the NRC Inspector General on NRC's compliance with NOED policy and procedure, and public comments received in response to the September 1994 *Federal Register* notice. The staff is providing a separate paper to the Commission on NOED policy.

### ***Section I.C: Overview of Current NRC Enforcement Program***

The NRC's enforcement program is guided by the Commission's "General Statement of Policy and Procedure for NRC Enforcement Actions" (Enforcement Policy). The procedural requirements for enforcement actions are found in 10 CFR Part 2, Subpart B. The Enforcement Policy itself is published at 10 CFR Part 2, Appendix C, to provide widespread dissemination of the Commission's enforcement philosophy and guidance. Despite being published in the Code of Federal Regulations, however, the Policy is considered *only* a policy, and not a regulation. As such, the introduction to the Policy notes that the Commission, as appropriate under the circumstance of a particular case, can deviate from it.

The Enforcement Policy was first published in 1980 as an interim policy (45 FR 66754, October 7, 1980). On March 9, 1982 (47 FR 9987), the Commission published a final version of the Policy. Since that time, it has been modified on a number of occasions to address changing requirements and additional experience. The current Enforcement Policy is contained in the 1994 Code of Federal Regulations, supplemented by a July 15, 1994 (59 FR 36026) modification to address decommissioning and decontamination matters and a November 28, 1994 (59 FR 60697) modification to address certain discrimination matters.

In addition to the Commission guidance in the Enforcement Policy, the NRC Office of Enforcement, which is responsible for the management of the NRC Enforcement Program, has issued the *NRC Enforcement Manual*, NUREG/BR-0195. This manual, which is publicly available, provides guidance for the NRC staff who prepare, review, and coordinate enforcement actions. The manual provides detailed delegation and implementation information relevant to each step in the escalated and non-escalated enforcement process for various NRC enforcement actions.

#### ***1. Severity Levels***

The Enforcement Policy provides for a graduated set of sanctions based on the severity of the violations. Normally, each violation or grouping of violations is categorized into one of five severity levels based on the relative importance of the violation, including both the technical significance (i.e., the actual and potential consequences) and the regulatory significance, including any willfulness associated with the violation. Specific examples of severity levels for particular violations are given in the Enforcement Policy supplements to improve consistency and enhance the ability to apply the Policy. Enforcement actions involving CPs, orders, or violations at SL I, II, or III are considered significant and are referred to as "escalated actions." An SL IV violation for which a CP is issued is also considered an escalated action.

## 2. *Enforcement Conferences*

When the NRC learns of a potential violation for which escalated action may be warranted, the NRC normally gives the licensee an opportunity for an enforcement conference before taking enforcement action. A conference may also be held for an SL IV violation if increased management attention is warranted. The purpose of the conference is to discuss the potential violations, their significance, the reason for their occurrence including the root causes, and the licensee's corrective actions. The conference provides NRC management an opportunity to emphasize, directly with senior licensee management, the significance of the violations and the need for effective lasting corrective action. Also, the NRC uses the conference to determine whether there were any aggravating or mitigating circumstances, and to obtain any other information (including licensee questioning of the inspection findings) that may assist in determining the appropriate enforcement action.

Enforcement conferences are not routinely open to the public. However, a trial program to open about 25% of the conferences to the public is currently underway (see Section I.A, Footnote 2).

## 3. *Enforcement Actions*

Formal sanctions include Notices of Violation (NOVs), CPs, and orders. In selecting the enforcement sanctions to be applied, the NRC will consider enforcement actions taken by other Federal or State regulatory bodies having concurrent jurisdiction, such as in transportation matters. If a violation of NRC requirements is identified, some enforcement action is usually taken. The nature and extent of the enforcement action is intended to reflect the seriousness of the violation involved. For most noncompliances, a Notice of Violation is the normal enforcement action.

## 4. *Notices of Violation*

A Notice of Violation (NOV) is a written notice used to formalize the identification of one or more violations of a legally binding requirement. The NOV requires the recipient to provide a written statement, normally describing: (1) the reasons for the violation or, if contested, the basis for disputing the violation; (2) corrective steps that have been taken and the results achieved; (3) corrective steps that will be taken to prevent recurrence; and (4) the date when full compliance will be achieved. The provisions for issuing an NOV are found in 10 CFR 2.201.

Under certain circumstances set forth in the Enforcement Policy, the NRC may choose not to issue a formal NOV. Use of a Non-Cited Violation (NCV), as this process is called, is



designed to provide incentives for identification and corrective action for violations at SL IV, as well as to save both NRC and licensee resources for violations at SL V. In general, where the licensee has identified a non-recurring violation at SL IV and taken appropriate corrective action, the inspection finding is documented in the inspection report and closed out as an NCV, with no written response required.

In addition, licensees are not ordinarily cited for violations resulting from matters not within their control, such as equipment failures that were not avoidable by reasonable licensee quality assurance measures or management controls. Generally, however, licensees are held responsible for the acts of their employees. Accordingly, this policy should not be construed to excuse personnel errors.

The materials program uses NRC Form 591, "Safety Inspections," which allows an inspector to document less significant violations and, after the licensee signs the form stating that corrective action will be taken within 30 days, serves as an NOV. Form 591 is generally issued by the inspector directly to the licensee without further agency review at the conclusion of the inspection.

In addition to NOVs, the NRC issues two other types of enforcement actions as notices requiring response. A Notice of Deviation is used when a licensee has failed to keep a written commitment to the NRC (or failed to adhere to a code, standard, guide, or accepted industry practice), but did not otherwise violate an NRC requirement. A Notice of Nonconformance is issued to a vendor or certificate holder who has failed to meet contract requirements related to NRC activities, in situations where the NRC has not placed requirements directly on the vendor or certificate holder. Both of these enforcement actions are more limited in scope (and less frequently used) than NOVs.

## **5. *Civil Penalties***

A civil penalty (CP) is a monetary penalty that may be imposed for violation of (1) certain specified licensing provisions of the AEA or supplementary NRC regulations or orders; (2) any requirement for which a license may be revoked; or (3) reporting requirements under Section 206 of the Energy Reorganization Act. Civil penalties are intended to emphasize the need for lasting remedial action, and to deter future violations both by the licensed party and by other licensees conducting similar activities. Section 234 of the AEA authorizes the NRC to issue CPs of up to \$100,000 per violation per day. It further provides that each day a violation continues a separate assessment may be made. The AEA does not provide any guidance as to how this authority should be applied (see discussion under legislative history, Appendix C). The procedures for issuing CPs are found at 10 CFR 2.205.

The Enforcement Policy in Table 1A establishes base CPs for different types of licensees. Generally, operations involving greater nuclear inventories and greater potential consequences to the public and licensee employees receive higher CPs. Table 1A provides a single penalty amount for a given type of licensee though there can be a wide range in sizes, abilities to pay, and potential hazards (e.g., large, broad-based hospitals vs. small rural community hospitals, large research reactors vs. very small reactors, or national radiography firms vs. one-person radiographers).

The Enforcement Policy provides factors to adjust CPs to an amount higher or lower than the base amount. These factors are designed to encourage good performance (e.g., prompt identification, prompt and comprehensive corrective action, and ensuring that violations do not recur) and to deter poor performance (e.g., the failure to identify the problem, the lack of prompt or comprehensive corrective action, not being responsive to opportunities to identify violations, and allowing violations to recur). The maximum percentage provided for each factor collectively allows a total range of reductions of up to 200% subtracted from the base CP or increases up to 500% above the base CP. In addition, discretion is allowed to further adjust the penalty amount, to ensure that the resulting action reflects the level of NRC concern regarding the violation at issue, and conveys the appropriate regulatory message to the licensee.

#### **6. *Orders and Confirmatory Action Letters***

Sections 161 and 186 of the AEA provide broad authority to issue a variety of orders. The NRC uses orders to modify, suspend, or revoke a license, to direct a licensee to cease and desist from a specific practice or activity, or to address deliberate misconduct by persons subject to NRC jurisdiction.

Confirmatory Action Letters (CALs) are documents that reflect commitments made by a licensee that may in some cases reflect significant obligations. Unlike an order, a CAL does not create a legal obligation other than a reporting requirement (under Section 182 of the AEA) if an obligation is not met.

#### **7. *Discretion***

The Enforcement Policy in Sections VII.A and VII.B provides guidance on when discretion may be exercised. This may result in either escalating or mitigating an enforcement sanction, to ensure that the resulting enforcement action appropriately reflects the level of NRC concern, and conveys the appropriate regulatory message to the licensee. Section VII.C. of the Enforcement Policy, entitled "Exercise of Discretion for an Operating Reactor," addresses "Notices of Enforcement Discretion" (NOEDs).

**8. Enforcement Data**

Appendix E provides data concerning escalated enforcement actions during the past 6 years. Table E-1 shows the frequency of various activities associated with escalated actions, including enforcement conferences, NOVs without CPs, CPs, orders imposing CPs, enforcement orders, and hearings requested on enforcement actions. Table E-2 lists the numbers of NOVs at SL I, II, or III, both those issued with CPs and those without CPs, separated by type of licensee.



## *Part II: Discussion of Issues*

This part of the report addresses the review and analysis of information considered by the Review Team. The organization is generally consistent with that of the questions presented for comment in the August and September 1994 *Federal Register* notices. However, the discussions on severity levels and Notices of Violation have been grouped into one section (II.B), a section on implementation has been added, and several minor sections were included in other areas.

- II.A Purpose and Objectives of the NRC Enforcement Program
- II.B Severity Levels and Notices of Violation
- II.C Enforcement Conferences
- II.D Civil Penalties
- II.E Other Sanctions
- II.F Violations Involving Willfulness and Individual Wrongdoing
- II.G Implementation, Delegation, and Oversight

Recommendations have been given at the end of each section or subsection. Recommendations designated with an asterisk (\*) are those involving staff action that, presumably, would not require Commission approval.



***Section II.A: Purpose and Objectives of the NRC Enforcement Program***

As stated in the existing Enforcement Policy (10 CFR Part 2, Appendix C):

The purpose of the NRC enforcement program is to promote and protect the radiological health and safety of the public, including employees' health and safety, the common defense and security, and the environment by:

- ◆ Ensuring compliance with NRC regulations and license conditions;
- ◆ Obtaining prompt correction of violations and adverse quality conditions which may affect safety;
- ◆ Deterring future violations and occurrences of conditions adverse to quality; and
- ◆ Encouraging improvement of licensee and vendor performance, and by example, that of industry, including the prompt identification and reporting of potential safety problems.

Issue A of the Review Team's August 1994 *Federal Register* notice asked questions associated with the purpose and objectives of the Policy. The topics covered included:

- ◆ the appropriateness of the purpose and objectives, as stated;
- ◆ the balance between punishment and incentives;
- ◆ the effectiveness of various sanctions in achieving comprehensive and lasting corrective action, deterrence, and improvement in performance;
- ◆ the clarity of the regulatory message as delivered by various sanctions;
- ◆ the consistency and predictability of sanctions (including any associated impact on the exercise of NRC judgment and Policy simplification);
- ◆ the effect of publicity on sanctions; and
- ◆ whether the NRC should have different policies for different types of licensees.

Each of these topics is addressed in this section.

***1. Appropriateness of the Stated Purpose and Objectives******a. Comments***

All commenters favored directing the focus of enforcement toward safety issues. Most commenters supported the stated purpose of the Policy. One commenter suggested that the phrase "promote and protect" should be changed to "protect" the public health and safety because the term "promote" suggests that there may be an endless spiral of increasing performance standards. Other commenters, while not taking issue with the

stated purpose, questioned whether, as implemented, the focus was on protecting the public health and safety. Those commenters took the view that enforcement action for violations of lesser safety significance dilutes the attention and resources of both licensees and the NRC that could otherwise be directed at more significant safety matters.

As to the Policy's objectives, most commenters agreed with the first three stated objectives, although several questioned the use of the term "prompt" as applied to corrective action and some questioned the relative need for enforcement as a deterrent (in addition to other existing deterrents to noncompliance). Commenters noted that NRC should consider the effect of other activities that influence licensees, such as facility shutdown time, Systematic Assessments of Licensee Performance (SALPs), management meetings, Public Utilities Commissions, insurance, financial markets, litigation, and public scrutiny. One commenter noted that, since 1980, the utility arena has changed with the creation of the Institute of Nuclear Power Operations (INPO), SALP, and resident inspectors, so that the effort to use enforcement to provide messages and get the attention of senior licensee management is no longer necessary. One commenter proposed adding the objective of removing individuals who willfully violate requirements. Some noted that enforcement may be warranted for poor performers.

A number of commenters disagreed with the fourth objective of encouraging improvement in performance. The basis of the objection was that, according to the commenters, a focus on improvement of performance results in adding rules informally (i.e., constitutes an attempt to amend regulatory standards without complying with the Administrative Procedures Act).

**b. *Maintaining a Safety Focus***

The principal statutory mission of the NRC is to protect the public health and safety.<sup>1</sup> NRC's regulations and license conditions reflect a degree of judgment as to what is required to protect the public and licensee employees from the hazards inherent in the use of radioactive material.<sup>2</sup> The Commission has historically emphasized (as stated in the introduction to the current Enforcement Policy) that licensees must demonstrate

---

<sup>1</sup>The term "public health and safety," as used in this report, means radiological health and safety of the public, including employees' health and safety. The NRC's Enforcement Policy and this report apply equally to violations involving the common defense and security and the environment.

<sup>2</sup>This idea was articulated in *Atlantic Research Corporation*, CLI-80-7, 11 NRC, at 413, 425 (1980).



meticulous attention to detail and maintain high standards of compliance.<sup>3</sup> As the Commission stated in *Atlantic Research*, given the potentially dangerous nature of nuclear energy and its applications, "when one becomes a licensee of this Commission he must accept and be held to an extraordinary responsibility for safety" (11 NRC, at 425).

The Review Team agrees that, as implemented, the enforcement program must maintain a clear focus on safety. Violations vary in their degree of safety significance; for that reason, the Enforcement Policy provides a graduated system of sanctions, varied according to safety significance. This graduated system appears both in the range of severity levels assigned to different violations, and in the availability of different enforcement actions (e.g., NCVs, NOVs, CPs, and orders).

Disagreements may occur as to the safety significance of any particular violation. In the view of the NRC, a violation need not result in actual impact to the public or to an employee (e.g., a release of radioactive material to the public or an employee overexposure to radiation) before it is considered significant. In resolving differing views on safety significance, considerations should include all aspects of safety significance as applied to enforcement, including the actual safety consequence, the potential safety consequence, and the regulatory significance.

This latter component of safety significance (i.e., regulatory significance) highlights the importance the NRC places on certain types of noncompliances, such as those involving willfulness. A willful violation has, by its nature, greater significance than a non-willful violation of the same requirement, because willful noncompliance undermines a basic tenet of the regulatory process: that is, it invalidates the basic assumption that licensees and their employees will act with integrity and candor. As a result, the Review Team believes that the enforcement program, in maintaining a focus on safety issues, should continue to include a strong emphasis of deterrence against willful violations.

As a final note in this area, the Review Team observes that, even with the emphasis on performance-based inspections, so-called "administrative" or "paper-work" violations are not always minor in safety significance. Many of the surveillance, quality control, and auditing systems on which both the NRC and the licensees rely (in order to monitor compliance with safety standards) are based primarily on complete, accurate, and timely recordkeeping and reporting.

---

<sup>3</sup>*X-Ray Engineering Co.*, 1 AEC, at 553, 555 (1960). See also *Hamlin Testing Laboratories*, 2 AEC, at 423, 428 (1964).

c. *Deterrence as an Enforcement Objective*

As noted earlier, some industry commenters characterized deterrence (as expressed in CPs and other enforcement sanctions) to be an unnecessary aspect of the NRC enforcement program. This viewpoint highlights other motivations for compliance, such as dual regulation by other agencies, reputation in the local community and among industry peers, the economic rewards of being a "good performer," professional dedication to quality, and the overriding motivation of safety. In such a context, these commenters state, the possibility of NRC enforcement action (including the threat of a CP) is superfluous; it accomplishes no additional improvement in licensee performance.

The Review Team considered this view, but continues to find deterrence, in its broadest sense, to be a legitimate goal of enforcement. All enforcement is, by nature, *after the fact*; while licensing, inspection, and other NRC functions can help to anticipate and prevent violations and other safety problems from occurring, enforcement action is only taken when the noncompliance has already occurred (i.e., after the other motivations for compliance have, at least in this instance, been insufficient). As such, enforcement action is intended to emphasize the importance of the requirement that was breached, to focus attention on what went wrong, to maximize the benefit of the lessons to be learned, and to achieve those goals in a *deterrent* fashion: that is, in a manner that discourages recurrence of the violation.

In the NRC enforcement program, deterrence is achieved in two ways. The first is by emphasizing the importance of compliance: that is, by applying an enforcement sanction commensurate with the safety significance of the noncompliance. The second aspect of deterrence is in giving credit for those licensee characteristics that will be most effective in avoiding continuing or future violations. These characteristics are prompt self-identification of violations and prompt, comprehensive corrective actions. Thus, in creating deterrence, the NRC enforcement program should include both punitive aspects and incentives (see discussion under Section II.A.2, below).

If the enforcement action is delivered properly, two audiences should receive the message of deterrence. The first audience is the licensee subject to the enforcement action. Ideally, that licensee, after being subject to the enforcement process, the resulting sanction, and the associated attention, desires not to have such a process repeated, and takes action to correct the violation, pursue and correct the root causes, and avoid similar future violations. The second audience--other licensees who could be subject to similar violations--should view the enforcement action as an opportunity to examine their own operations and avoid or correct any similar problems. In both

cases, the deterrent value of the enforcement should create an additional motivation for future compliance.

*d. Improving Performance as an Enforcement Objective*

The Review Team notes that many commenters disagreed with the objective of improving performance, on the grounds that enforcement might be applied in a manner that actually added rules without proper process. When a violation has occurred, licensees frequently take action (to address the root causes and prevent recurrence) in a manner that exceeds requirements. In such cases, while taking appropriate corrective action *is* required, the individual actions may of themselves *not* be requirements.

The Review Team agrees that enforcement should not be used to create new requirements. The intent of this objective is simply to suggest that improved performance should result when enforcement is applied to increase adherence to *existing* standards. After considering alternate viewpoints, however, the Team recommends removing this objective to eliminate ambiguity.

*e. Conclusion*

The Team concludes that the purpose and objectives, as stated in the current Enforcement Policy, were appropriate. The Team believes, however, that certain changes might be made to strengthen the focus and avoid misinterpretation. The overall purpose of enforcement should clearly be to supplement the NRC's overall safety mission of protecting the public, workers, and the environment. Within that purpose, the enforcement program should be geared toward creating deterrence (i.e., taking action in a manner that will effectively identify and correct violations that have occurred and discourage future violations) by (1) emphasizing the importance of compliance with requirements, and (2) encouraging prompt identification and prompt, comprehensive correction of violations.

**2. Achieving a Balance Between Punishment and Incentives**

*a. Comments*

A high percentage of commenters from industry responded to this issue, stating almost universally that the NRC enforcement program was too heavily focused on punishment. Many commenters felt that the punitive aspects of enforcement overshadowed any credit given for self-identification and corrective action. As a positive incentive for good performers, commenters suggested financial incentives (e.g., reduction in fees),

reduced inspections, and fewer documentation and reporting requirements. One commenter stated that the proper balance could only be achieved by making compliance more attractive than noncompliance (i.e., ensuring that enforcement action taken in response to a noncompliance would be sufficient to offset any economic benefit that might have resulted to the licensee from the noncompliance).

**b. *Punitive and Positive Aspects of NRC Enforcement***

In principle, deterrence can be achieved with either positive or negative inducements. That is, if one wishes someone not to do X, one can either pay him not to do it or punish him for doing it. Either way, you eliminate the advantage of doing X.<sup>4</sup>

Enforcement, by its nature, is negative. As acknowledged above, enforcement differs from certain other NRC activities because it occurs *after* a problem has already taken place. However presented, it is nonetheless a recognition that something bad has occurred.

On the other hand, enforcement actions sometimes highlight positive aspects of a licensee's performance. The NRC recognizes that in activities as complex as most nuclear operations, with hundreds and even thousands of requirements, some violations will inevitably occur. Based on this recognition, the enforcement program seeks to encourage those aspects of performance that will (1) minimize the negative effects of a noncompliance, and (2) maximize the lessons learned in a manner that will avoid future violations.

The incentive aspects of NRC enforcement generally appear as the reduction or removal of disincentives. Like most regulatory agencies, the NRC is somewhat constrained in its use of *positive* incentives (e.g., it cannot provide direct subsidies). More realistically, negative incentives are removed or reduced. For example, for a violation that would normally result in a CP, the licensee's prompt self-identification and prompt, comprehensive correction of that violation might legitimately result in no CP (but normally would still result in an NOV). Sustained good performance may result in reduced inspection oversight.

**c. *Improving Trends in Industry Performance***

Within this discussion, the Review Team considered a major contention made by

---

<sup>4</sup>From the Report of the Advisory Committee for Review of the Enforcement Policy (1985), p. 12.

industry commenters, that the existing trend toward improving industry safety performance calls for a substantial shift away from "punitive" NRC enforcement actions.

The relationship between NRC enforcement and the industry's improving performance trend is, obviously, open to interpretation. In other words, the data do not conclusively show whether industry's improvements have *resulted* from a vigorous enforcement program or have occurred *in spite of* an overly negative NRC emphasis (in the latter case, maintaining a strong enforcement program would be somewhat superfluous).

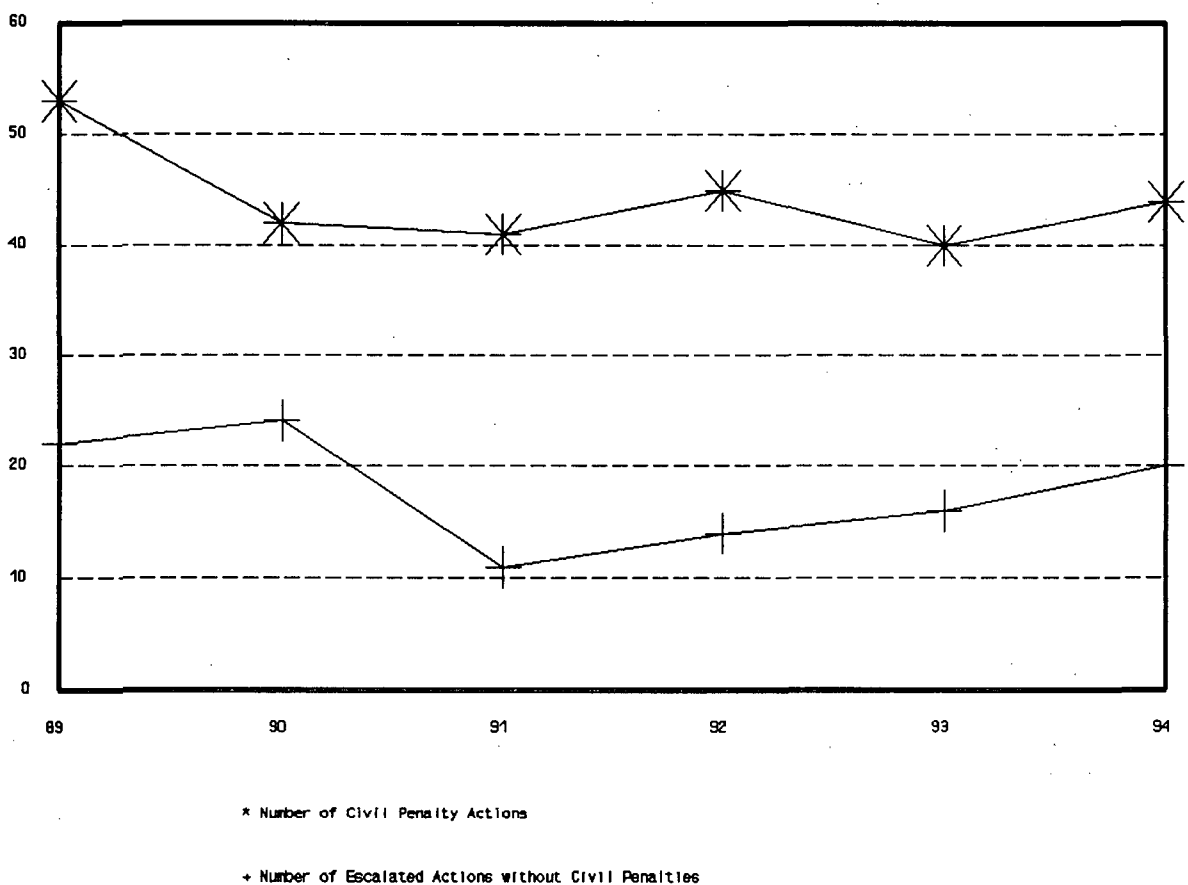

**Figure II.A-1: Number of Reactor Escalated Enforcement Actions**

The Review Team proceeded on the general premise that a strong enforcement policy, applied with discretion and judgment, can provide an effective deterrent against future

violations, by: (1) emphasizing the importance of adherence to requirements; and (2) reinforcing, by design, those aspects of licensee performance that are especially crucial in ensuring quality (e.g., self-identification of problems and root causes, prompt and comprehensive correction of errors, and recognition and avoidance of adverse trends).

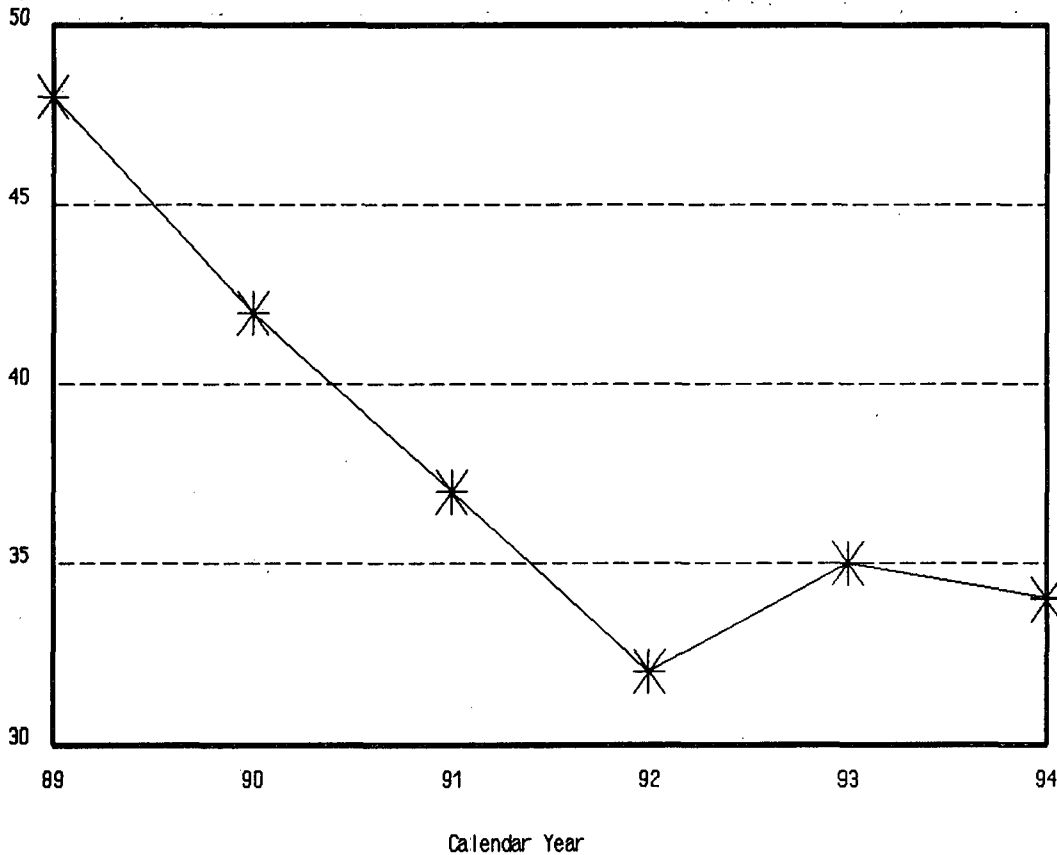

**Figure II.A-2: Number of Reactor Sites With Escalated Enforcement Actions**

In evaluating historical enforcement data, the Team observes that, as indicated by Figures II.A-1 and II.A-2, the number of CPs and other escalated actions being issued has remained relatively constant, but the number of licensees receiving these penalties appears to be decreasing (see, in addition, the data tables in Appendix E).

The Team takes this to indicate that, while overall industry performance has been improving, certain licensees have been less responsive than others in achieving high quality assurance standards (i.e., programs for prompt, effective identification and

correction of problems). These data do *not* support a substantial shift in policy (i.e., a shift away from a strong enforcement program); however, the Team finds that encouraging licensee excellence in self-identifying and correcting conditions adverse to quality is clearly consistent with safety and with the overall objectives of enforcement. The Team concludes that, if changes are made to the methods of assessing and issuing escalated enforcement actions, those changes should increase the incentives for strong self-monitoring and corrective action programs, and should focus the pressure on less responsive licensees to achieve high standards of safety performance.

*d. Conclusion*

In the Review Team's view, the proper balance between punishment and incentives involves retaining both aspects in the Enforcement Policy. The Team observes, however, that attempting to include both punishment and recognition of good performance in a single enforcement action may sometimes result in a mixed message. In such cases, the enforcement correspondence must be especially clear in outlining the reasons for the sanction as issued. The Team concludes that, where possible, any changes to the Enforcement Policy (1) should be structured to achieve clarity in the overall message delivered; and (2) should seek to strengthen the incentives for licensee self-identification and prompt, comprehensive corrective action.

*3. Effectiveness of Sanctions*

*a. Comments*

Several comments questioned the overall value of sanctions, stating that the NRC was focused more on compliance and less on significant safety issues, and that enforcement was therefore distracting both NRC and licensee resources and attention from significant safety issues. A number of commenters felt that enforcement should only be taken for violations of high safety significance. Some commenters found that the NRC, under the guise of providing a strong regulatory message, was causing licensees to make non-safety-related commitments, which are costly and time-consuming.

Similar comments stated that enforcement actions, as currently administered: (1) concentrated too often on vague, general requirements (e.g., 10 CFR Part 50, Appendix B criteria); (2) were driven by subjective, inspector-driven concerns; and (3) undermined NRC credibility by focusing on literal compliance and trivial violations in a manner that seemed inconsistent with improving industry performance.

***b. Differences Between Sanctions***

A basic tenet of the NRC enforcement program is that some violations are of more concern than others. Enforcement actions should be correspondingly applied on a graduated scale commensurate with the varying degrees of safety significance of violations. Under the current Policy, this scale ranges from NCVs to orders to revoke or suspend a license.

In addition, the sanctions issued may differ based on the licensee's responsiveness to the violation, the corrective action taken, and other relevant factors. For a specific SL III violation, the NRC's evaluation of the licensee's related actions might result in issuing only an NOV (with no associated CP), an NOV with a small-to-moderate CP, or an NOV with a substantial CP.

***c. Conclusion***

The Review Team believes that the NRC should continue to use a graduated system of enforcement actions, in a manner that reflects the varying safety significance of different violations, and which can be adjusted based on the circumstances of the violation, including the licensee's efforts to identify and promptly, comprehensively correct the problem or problems. In addition, the Review Team agrees that the NRC's efforts should be focused most on matters of greatest safety significance. In an overall sense, this focus should be directed at significant violations (problems categorized at SL I and II), licensees with multiple SL III problems, and willful violations.

***4. Clarity of the Regulatory Message******a. Comments***

A number of licensees were concerned with the language in cover letters that addressed weaknesses and management concerns that the NRC perceived were the root causes of violations. These commenters suggested that the cover letters be neutral, letting the violations speak for themselves and allowing the licensee's proposed corrective actions to address root causes. These commenters were also concerned that the NRC, in encouraging the licensee to address specific weaknesses, was essentially directing certain results in a manner that was not in fact based on the violations or on regulatory requirements.



***b. Enforcement Action Transmittal Letters***

Enforcement action transmittal letters communicate with a range of audiences, some more familiar than others with the inspection findings. While the primary audience is the involved licensee, secondary audiences may include site management, corporate officials not directly involved in nuclear activities, other licensees with similar activities, NRC staff, the media, and interested members of the public.

The *NRC Enforcement Manual* provides detailed guidance on preparing enforcement correspondence. The intent is to provide the reader with (1) a brief summary of the violations, (2) the NRC's perspectives on the significance of the violations (i.e., to support the severity level decision); (3) the areas of regulatory concern, their causes, and the licensee's response to them, (4) recognition of corrective actions taken and the need, where applicable, for additional actions, and (5) an explanation of how the sanction was derived.

The Review Team disagrees with the contention that these letters should be neutral and simply transmit the enforcement sanction. The letters serve a valuable purpose in making sure that licensees and other audiences understand NRC concerns and expectations. As such, the letters should be constructed to convey the regulatory message derived from applying the Enforcement Policy to the circumstances of the particular case.

On the other hand, with the evolution of new enforcement insights and shifting emphases, the length of these letters has increased in an attempt to better convey the message. The NRC has encouraged, for instance, including a description of the licensee's corrective action, to give credit where good action has been taken. By emphasizing those aspects of licensee commitments that the NRC considers important, other licensees gain ideas on how to improve their performance in similar areas. In addition, the letters may address the need to avoid violations, the need to be responsive to opportunities to identify violations, the need to reverse past poor performance and sustain good performance, the significance of multiple violations, the impact of violations of extended duration, and the need to maintain high standards of integrity.

As the transmittal letters get longer, they may communicate less effectively, especially for those not familiar with the underlying inspection findings. The Review Team believes that enforcement correspondence should continue to be used to provide a regulatory message, including the NRC's perspectives on the violations and the need for corrective action. However, the Office of Enforcement should review the guidance to simplify and shorten the letters. Briefer explanations of the violations and events

and internal references to details of the NOV or inspection report may be ways to increase clarity without diluting the desired regulatory message.

*c. Complexity of the Message*

The Review Team observes that, under the current system, the NRC may be attempting to send multiple messages within the issuance of a single sanction. For instance, for a single SL III problem identified and corrected by the licensee, the NRC will generally issue the SL III NOV and transmittal letter (acknowledging the safety significance of the problem), but may choose to fully or partially mitigate the CP (recognizing the licensee's commendable actions). In the same case, a CP may be issued, or even issued at an escalated amount, because the licensee had a history of poor performance in the area of concern, or because the violation existed for an extended duration--or because the violation, while categorized at SL III, involved an overexposure or release of radioactive material. The resultant cover letter may try to convey each of these messages, some negative, some relatively positive, each couched within a weighting factor or severity level as part of the single overall sanction.

While the current system is not unworkable, the Review Team believes that trying to convey too many messages in a single sanction may at times result in confusion, or may result in not achieving a clear message of what the NRC finds to be most important. For example, some may argue that a licensee who is trying to reverse a trend of negative performance may be discouraged when a self-identified and corrected violation still results in a CP action, due to escalation for the poor past performance. In such a circumstance, the strength of any regulatory message may be diluted.

As a secondary concern, the Review Team observes that attempting to incorporate multiple messages into a single sanction may result in internal NRC inefficiency, because of differences of opinion on how the various messages should be weighted. The inspector might feel, for example, that the licensee's failure to capitalize on earlier opportunities to identify the violation outweigh the fact that it was, eventually, licensee identified. The section chief, however, might feel that both the prior opportunity and the eventual identification are less relevant than the overall good performance this licensee has shown--performance in which the present issue seems relatively isolated and uncharacteristic. A third NRC reviewer might emphasize another point (e.g., that the safety significance of the violation, in this instance, should override all mitigating factors). The more decision points applied in assessing the final sanction, the greater the potential for regulatory inefficiency, and the higher the chance of a resulting complex regulatory message.

*d. Conclusion*

The Review Team concludes that any changes proposed to the overall Enforcement Policy should bear in mind the need to convey a clear regulatory message (as well as the need for efficiency), and should attempt to minimize the number and complexity of decision points while preserving the desired emphases of the current Policy. In addition, the Team recommends that the Office of Enforcement (OE) review the existing guidance on enforcement correspondence, to simplify and shorten standard letters to better convey regulatory concerns.

**5. Consistency and Predictability**

*a. Comments*

Commenters generally favored a high degree of consistency in enforcement, and preferred centralized review of enforcement actions to ensure that consistency. Some industry commenters gave specific suggestions on making the Enforcement Policy more specific to minimize inconsistency among inspectors and regions. Several asked that a third-party appeal process be created to ensure consistent Policy application and safety focus.

*b. Discussion*

In addition to maintaining the clarity of the regulatory message, the Review Team believes that enforcement actions, to be effective, should be predictable and relatively consistent. For instance, if separate violations occur in different regions but are characterized by essentially the same sets of facts, then the resulting sanctions should be similar, if not identical.

This predictability is especially important in strengthening the deterrence associated with providing incentives for positive aspects of licensee performance. If the NRC wants to encourage licensee identification and prompt, comprehensive correction of violations, then that encouragement must be credible; the licensee should feel assured that, ordinarily, the result described in the Enforcement Policy will in fact appear in the sanction issued (e.g., full mitigation of the CP for a self-identified and corrected non-willful SL III). In other words, the licensee's paths to full mitigation of the CP should be clearly defined and, where deserved, should be consistently applied in NRC assessments.

Consistency is also important in making more punitive sanctions an effective deterrent.

Even when disagreements exist, the licensee should not feel that a decision has been made arbitrarily, either to mitigate or escalate a sanction. Routine cases should result in routine application of the Policy, and departures from the routine should be clearly justified.

On the other hand, the Enforcement Policy should not be reduced to a formula for rigid application. Few cases are entirely straightforward, and the NRC must always apply judgment in determining whether to give credit for the licensee's actions. Despite years of industry experience, new types of cases frequently arise, and in some cases, strict application of the Policy could result in delivering an inappropriate message.

In addition to allowing judgment on individual decision points, the Review Team believes that the Enforcement Policy should designate certain types of cases as warranting discretion. For example, violations categorized at SL I and II, by definition, involve either actual or potential impact on the public, and therefore should be considered for additional attention. Similarly, it may be difficult to use an assessment formula for achieving the proper regulatory message for a violation involving willful wrongdoing on the part of the licensee or a licensee employee.

*c. Conclusion*

The Review Team recommends that the Enforcement Policy be simplified in a manner to ensure, where possible, a consistent and predictable result. This change should reinforce the overall objectives of the enforcement program and highlight the actions expected of licensees in order to achieve the "path to success." However, efforts to achieve consistency should also recognize the need to preserve judgment, and should provide guidance on the types of non-routine situations that may warrant applying discretion.

**6. *The Effect of Publicity***

*a. Comments*

In general, industry respondents stated that the impact of press releases had been to create unwarranted negativity in the public's view of nuclear licensees. Several commenters stated that NRC press releases serve more to embarrass the licensee and enhance NRC credibility than actually to benefit the public. Some commenters asked that the NRC stop issuing multiple press releases for a single problem (i.e., at different stages of the enforcement process). Others felt that press releases should be limited

to extraordinary situations where detailed technical public information is needed.

The most consistent argument opposing the NRC's use of press releases was that, in seeking to inform, they actually confuse the public. Commenters mentioned this confusion in relation to (1) the NRC issuing multiple press releases for a single problem (i.e., at different stages of the enforcement process), (2) national press releases implying an event of national importance, (3) diluting public attention as to what is important, and (4) creating an unbalanced public image for nuclear licensees, since the NRC rarely issues positive press releases. One commenter characterized the resulting situation as one in which: (1) the NRC makes a case for significance, (2) the licensee makes the case for realism, and (3) the public is confused by the perception of an adversarial NRC/licensee relationship.

*b. Discussion*

For most enforcement actions (i.e., those not associated with safeguards, proprietary, or other similarly protected information), all final documents associated with the action are placed in the Public Document Room (PDR). This typically includes the inspection report, a summary of the enforcement conference (including the licensee's presentation materials, if applicable), and a copy of the final action (e.g., NOV with no CP, or NOV with proposed imposition of CP).<sup>5</sup> In addition, the NRC has traditionally issued a press release to announce the issuance of a proposed CP action or order (see also the discussion, in Section II.C.2.e, of press releases for open enforcement conferences).

Public disclosure of enforcement actions is warranted simply on the basis that the NRC should conduct its business in the public eye; however, all parties (the NRC, industry groups, and other commenters) acknowledge that the publicity associated with certain escalated actions significantly augments the deterrent effect of those actions. In particular, the press release associated with a proposed imposition of a CP reaches a substantially broader media audience than is likely to frequent the PDR, and many licensees feel that the press coverage of a proposed CP can be far more damaging than the dollar amount of the actual CP.

Issuing press releases to announce proposed CPs is important because the CPs represent a significant NRC action (i.e., more significant, based on safety significance and/or licensee response to the violation, than an NOV issued without a CP). The Team

---

<sup>5</sup>The NRC also periodically publishes NUREG-0940, "Significant Enforcement Actions Resolved," which includes a copy of the final version of all escalated enforcement actions for that period, including the accompanying transmittal letters.

believes that such information should be volunteered to the public at the time the action is proposed. Persons living near the plant, as well as other members of the public, should be informed of significant agency actions at the time they occur.<sup>6</sup>

On the other hand, the Review Team gives some weight to the licensee's view that the adverse publicity associated with escalated enforcement actions can undermine public confidence in the licensee, and in the industry in general. Newspaper accounts frequently deal more strongly with the negative aspects associated with the violation, and subsequent positive developments rarely come to the public's attention. A single enforcement action may result in several occasions for publicity (i.e., at the times of the initiating event, the enforcement conference (if open; see discussion in Section II.C.2.e), the announcement of proposed CP, any licensee attempts to contest the NOV or ask for CP mitigation, and the payment of the final penalty). To the public, it may appear that the licensee has had several distinct issues of noncompliance. In short, the NRC's attempts to keep the public informed reinforce the deterrence; the licensee's motivation to improve future performance may be influenced more by avoidance of adverse publicity than by avoidance of the enforcement action itself.

*c. Conclusion*

The Review Team recommends that the NRC maintain its current practice of conducting enforcement in the public eye, including issuing press releases for proposed impositions of CP (see separate recommendation regarding press releases for open enforcement conferences). The Team also recommends that, in issuing such press releases, the NRC should continue to make every effort to ensure that the information presented is factual and balanced.

**7. *Considering Different Policies for Different Types of Licensees***

*a. Comments*

Several commenters suggested that there should be one Enforcement Policy, uniformly applied, based on the significance of the violations and not on the type of licensee. Others noted that a given violation may have varying degrees of significance depending on the type of activity. Commenters also stated that the Enforcement Policy, by its application, should account for the acute public health hazard from power reactors being more significant (in the commenter's view) than that from materials licensees.

---

<sup>6</sup>An exception to this approach might be warranted when individuals are accused of wrongdoing. It is appropriate in such cases to obtain a response from the individual before deciding to publicly release the material.

***b. Discussion***

The Team evaluated the need for different enforcement policies both in a broad-scope sense (i.e., general enforcement principles) and in relation to specific implementation issues. In general, the Team believes that the purpose and objectives of the NRC enforcement program apply to all types of NRC licensees. For both reactor and materials licensees, enforcement should seek to achieve deterrence by emphasizing compliance and encouraging self-identification and correction of problems. Concepts such as maintaining a safety focus, balancing punishment and incentives, providing clear, focused communication, and seeking consistency and predictability are similarly applicable to both types of licensees.

In addition, the Team recognizes the benefit of implementing the Policy, to the extent possible, in a manner similar for all types of licensees. For example, the logic of having multiple severity levels is equally useful for materials and reactor noncompliances. Using the same strategy for CP assessment is considerably easier for the regulator than having various strategies for various licensees.

On the other hand, the Team believes that implementation should not force similarity where differences are appropriate. The current Policy distinguishes the amounts of base CPs for power reactor licensees from those for various types of materials licensees. These differences are based on the size and characterization of the licensee's material inventory, the scope of licensed activities, the degree of hazard, and other similar factors. In addition, many materials licensees are inspected much less frequently than power reactors, and they may be less familiar with NRC enforcement practices. The Team believes that some differences of implementation are appropriate.

***c. Conclusion***

The Team concludes that the NRC should continue to maintain one overall Policy for materials and reactor licensees, in terms of general principles and philosophy. In Policy implementation, the Team believes that current practice should continue: general strategies such as CP assessment methods should be as similar as practical; the severity of sanctions and the construction of enforcement supplements should recognize the differences between licensee size, type, activities, and associated hazards; and methods of dealing with licensees (e.g., in enforcement conferences) should be varied as needed.

**8. Recommendations**

**a. Recommendations to the Commission**

The Review Team recommends:

II.A-1 That the purpose of the enforcement program, as stated in the Enforcement Policy, be modified to read as follows:

The purpose of the NRC enforcement program is to support the NRC's overall safety mission in protecting the public, workers, and the environment. Consistent with that purpose, enforcement actions should be used to create deterrence by:

- ◆ Emphasizing the importance of compliance with requirements, and
- ◆ Encouraging prompt identification and prompt, comprehensive correction of violations.

**b. Recommendations to the Staff**

The Review Team recommends:

II.A-2\* That the Office of Enforcement review existing staff guidance on enforcement correspondence, to simplify and shorten standard letters to better convey regulatory concerns.



### *SECTION II.B: Severity Level and Notices of Violation*

This section addresses Issue B, "Severity Level of Violations," and Issue D, "Notices of Violation" of the August 1994 *Federal Register* notice. Under the current Policy, five severity levels are used to categorize the significance of violations. A Notice of Violation (NOV) is normally issued for a violation, regardless of severity level. However, Section VII.B of the Enforcement Policy describes certain SL IV and V cases in which, instead of issuing a formal citation, the violation may be labeled as a Non-Cited Violation (NCV).

The Review Team sought comments on:

- ◆ whether the NRC should continue to use five severity levels;
- ◆ whether the Enforcement Policy gives enough examples of the various severity levels;
- ◆ whether the NRC should continue to use NCVs;
- ◆ whether NCVs contribute to the incentive for self-identification;
- ◆ whether NCVs should be treated differently than other violations in considering enforcement history;
- ◆ whether NOVs should be issued for SL V violations;
- ◆ whether written responses should be required for all NOVs; and
- ◆ whether Form 591s should be expanded for use in fuel cycle and reactor cases.

#### *1. Comments*

Many commenters supported retaining five severity levels, based on varying degrees of safety significance. Some, however, favored eliminating SL IV and SL V, or renaming these less significant violations as "non-material discrepancies." This term, as proposed, would apply to administrative violations having little or no impact on plant hardware, and would result in a less punitive, non-enforcement process. Some commenters stated, in addition, that issuing SL IV and V violations for minor concerns creates confusion and undermines developing an accurate picture of a licensee's more meaningful safety strengths and weaknesses.

Commenters also favored more specificity in the examples, to allow less judgement in applying severity level criteria to specific situations. Several commenters asked for more discipline in the NRC process for assessing a violation's safety significance. For example, probabilistic risk assessment (PRA) and individual plant examination (IPE) results were suggested as techniques for developing a more credible, reliable assessment of a violation's true safety significance. Other commenters suggested revising specific examples, such as those addressing degraded systems (Example I.C.2.b in the Policy), breakdown in the

control of licensed activities (I.C.7 and IV.H.13), substantial potential for an overexposure (IV.H.8), and fitness-for-duty matters (VII.B.7).

Almost all commenters favored an expanded use of NCVs under the existing criteria. NCVs were viewed as a direct incentive for self-identification. Some responses also pointed out the positive impact NCVs have on the public perception of a licensee's level of safety. Some asked that NCVs be used for licensee-identified and corrected SL III violations. One commenter, however, favored eliminating NCVs, claiming that they inhibit the detection of emerging trends, and suggesting that if a requirement is not worth citing, it should be reconsidered (rather than *not* citing an existing regulation). Another commenter suggested renaming NCVs to avoid a public perception that licensees are being allowed to violate safety regulations.

Several commenters agreed that NCVs should be included whenever a licensee's enforcement history is being considered. These commenters generally found NCVs to be a positive indicator of a licensee's good questioning attitude and commitment to safety and self-monitoring.

Some commenters felt that all NOV's should require a written response; others felt that minor NOV's should not require a written response. Some respondents pointed out that, where the inspection report gave essentially the same information that would appear in the written response, a licensee response to the NRC should not be necessary.

Finally, none of the reactor or fuel cycle commenters sought to expand the use of Form 591s to their activities.

## **2. *Violation Significance***

Violations vary in safety significance. As stated in Section II.A.3.b, enforcement actions should be correspondingly fitted on a graduated scale in a manner commensurate with the significance of the violations. As a starting point, the NRC uses severity levels to categorize violations by different levels of significance.

The five current severity levels are described as follows:

SL I and II violations are by definition of very significant regulatory concern. These violations generally involve integrity issues or involve actual or high potential impact on the public, employees, safety equipment, or the environment.

SL III violations are cause for significant regulatory concern. Such violations require

prompt and comprehensive corrective action because of their potential for impact on safety.

SL IV violations are of more than minor concern and need to be corrected. If left uncorrected, they could lead to a more significant concern.

SL V violations are of minor concern, and do not normally require NRC attention. Even if such violations persist, they would not be expected to lead to a significant regulatory concern.

Based on the number and variety of licensed activities the NRC regulates, the range of potential safety problems and situations to which the enforcement program must be applied cannot easily be anticipated or defined. In developing enforcement policy and practice, the NRC continually acknowledges the need for substantial flexibility. Thus, by design, the definitions of severity levels are general, and leave latitude for judgment in fitting the circumstances of a violation into the appropriate category.

Recognizing the need for flexibility, the Review Team does not support adopting narrow severity level definitions, such as connecting the levels to PRA analysis. To provide consistency in assigning severity levels, the Policy lists examples in eight supplements, each representing an activity area. As the Policy states, comparison of significance between activity areas may not be appropriate. The examples in the supplements are neither controlling nor exhaustive. Judgment must be applied in assigning the appropriate severity level to the circumstances of any case. Unusual circumstances, such as direct repetitiveness or willfulness, can increase the severity level. Violations may be aggregated into an overall problem, and the overall problem used to categorize significance.<sup>1</sup>

The Review Team believes that some of the comments show misunderstanding of the standards used to categorize the significance of violations. The NRC's basis for severity level categorization clearly is safety significance; however, this does not mean that a violation must have safety *consequences* to be of significant concern. In judging safety significance, the NRC considers (1) actual consequences, (2) potential consequences, and (3) regulatory significance. Regulatory significance involves such NRC concerns as repetitiveness, willful violations, and the submission of inaccurate and incomplete information.

### ***3. Review of Severity Level Examples***

The Review Team believes it is appropriate to continue using three levels of significant

---

<sup>1</sup>SL I and II violations are not normally aggregated.

violations to distinguish among significant violations. Historically, relatively few cases have involved SL I and II violations, compared to the number of SL III cases. The table below shows this comparison for 1993 and 1994.

*Table II.B-1: Number of Significant Cases in 1993 and 1994*

	SL I	SL II	SL III
Reactor Cases	1	5	110
Materials Cases	5	14	156

Non-escalated cases (i.e., SL IV and V violations) are tracked by individual violations, rather than enforcement actions, and are much more numerous. In 1993, for example, about 900 SL IV violations and about 30 SL V violations were issued.<sup>2</sup>

The examples in the Enforcement Policy supplements are generally adequate for categorizing the severity level of this wide range of violations. These examples need periodic review, however, to ensure they continue to reflect current regulatory views. Over time, the examples have been changed to reflect experience and changing requirements.

The Review Team considered the comments requesting reconsideration of specific examples in the supplements. Without agreeing or disagreeing with the changes recommended by various commenters, the Team does recommend that OE work with NRR, NMSS, and the regions to review the severity level examples in the supplements, to see if any changes are warranted to ensure a continued focus on safety significance. In some cases the examples may be adequate, but additional guidance may be needed to clarify application (e.g., describing circumstances for determining when individual violations constitute a breakdown of control in licensed activities).

#### **4. Severity Level IV and V Violations**

The Review Team believes that the NRC should continue to use formal citations to document SL IV violations, as being of more than minor concern. To do otherwise would remove the ability to formally address less significant regulatory concerns that have the potential, if not corrected, to become precursors to problems of greater safety significance. However, in appropriate cases where the licensee has identified the violation and corrected

<sup>2</sup>For additional comparison, note that the materials and reactors inspection program had over 2000 inspections each in 1993, with less than 5% of those inspections resulting in an SL I, II or III violation.

it, formal citations need not be issued. As noted below, the NRC should continue to use NCVs for SL IV violations. The Team does not recommend, however, that the use of Form 591, "Safety Inspections," be expanded to include fuel cycle or reactor facilities.

*a. Deletion of Severity Level V Categorization*

The use of SL V violations has decreased over time. Based on the 1992 Enforcement Policy revision, SL V violations, even if NRC-identified, can be treated as NCVs so long as they are not willful, not recurring, and properly corrected (and the corrective action described in the inspection report). Because they are classified as minor, SL V violations are not likely to become a significant concern even if repeated several times.

In view of their minor nature, and considering how rarely they are used, the Review Team recommends deleting SL V as a category. Under this approach, violations of minor concern should not be the subject of formal enforcement action. Based on the limited significance of these violations, a licensee response is not needed nor should NRC effort normally be expended to check on the corrective action. In those few cases where a licensee repeatedly commits a minor violation or does not take corrective action such that a formal response would be needed, the violation should be categorized at SL IV. Additionally, since willful violations in themselves have a degree of regulatory significance, willful minor violations should be categorized at least at SL IV, as provided for in Section IV.C of the current Policy.

Since SL IV violations may result in formal enforcement action and minor violations will not, it is important to define the threshold for when a violation is considered minor. A test of whether a violation should be categorized as a minor violation is whether, if it recurred several times, it would still be of minor concern. Such violations normally are characterized by (1) having no actual impact and little or no potential for impact on safety, (2) being isolated, evidencing implementation and not programmatic weaknesses, and (3) relating to licensee administrative limits rather than to NRC regulatory limits. For example, an isolated record-keeping failure may be a minor violation. However, where record-keeping problems interfere in the ability to monitor or audit activities or identify performance problems, the failures are more significant.

From the standpoint of consistency, the Team recognizes that other than the brief words in the Enforcement Policy, guidance has not been issued for minor violations. This is because the focus in the enforcement program has been on the more significant violations. Consequently, it is important to develop better guidance as to what should be considered a minor violation.

The Team recognizes that, in terms of actual impact, this recommendation will change very little. Under the current system, an SL V violation is seldom cited unless willful or recurring, and frequently may not even be documented in an inspection report. However, this change may assist the agency in keeping its focus on violations of more significant concern.

***b. Responses to Notices of Violation at SL IV***

SL IV violations are typically violations that may have an impact on equipment, interfere with monitoring and auditing activities, demonstrate programmatic weaknesses, and/or other failures that if uncorrected may lead to more significant concerns. For these violations, the licensee should be identifying the root causes and taking comprehensive corrective actions so that the violations will not lead to more significant concerns. The NRC normally requires the licensee to respond in writing on the docket for these violations.

In some cases, however, the NRC may determine that the information normally required in such a response has already been adequately addressed on the docket (e.g., in a Licensee Event Report), and that no additional response, therefore, is needed. In addition, if the NRC inspection report adequately describes the licensee's corrective actions, the NRC may decide that no additional response is required, unless the licensee determines that the inspection report does not accurately characterize the corrective actions taken or planned. While a licensee is always free to provide additional information, the Review Team believes that 10 CFR 2.201, which establishes legal NOV requirements, should be interpreted as not requiring a written response if the staff is satisfied that the needed information is already adequately addressed on the docket.

**5. *Non-Cited Violations (NCVs)***

Section VII.B.2 of the current Enforcement Policy provides the staff with the discretion not to issue citations for certain SL IV licensee-identified and corrected violations. Issuing an NCV does not change the fact that a violation occurred, but it is intended to encourage the voluntary identification and correction of violations. Based on the review of comments, the NRC's use of NCVs is viewed as having a positive impact on overall safety, and the Team supports its continuation.

While the use of NCVs is discretionary, it should also be consistent. If the NRC decides to issue an NOV, rather than an NCV, for a licensee-identified and corrected SL IV violation, the reason for the decision should be articulated in the accompanying

documentation. As an example, the violation may be repetitive, and past corrective action considered inadequate.

*a. Use of Non-Cited Violations for SL III Violations*

The Team does not believe that the use of NCVs should be expanded to include SL III violations, as some commenters suggested. Violations at that level are considered significant, and the use of an NCV could dilute the seriousness with which the NRC views such matters. Regardless of who identifies SL III violations, their root causes should be documented, the corrective action described on the public record, and the need for other action (such as an enforcement conference) evaluated. As described in Section II.D, other incentives should be provided for identifying and correcting SL III violations; however, the NRC practice of issuing at least an NOV for SL III cases may help to deter such violations from occurring.

*b. Documenting Non-Cited Violations*

Although the enforcement process normally begins with the description of potential violations in the inspection report, the enforcement program does not dictate what matters an inspector should document. Some discretion clearly applies; not every potential NCV need be documented in an inspection report.

Given the inspection program's focus on safety, inspectors are not normally expected to document violations of minor concern. However, at times there may be reasons why NRC wishes to document minor violations in an inspection report. It might be appropriate to do so when the pursuit of allegations identifies minor violations. A significant matter may involve several associated violations, some of which may be minor. For completeness it may be warranted to describe these minor violations. Treatment of such violations as NCVs will preserve a method to disposition minor matters.

The Review Team believes, as noted above, that added guidance is needed in this area to ensure that inspectors are not focused on less significant matters, and to protect inspectors from being accused of not pursuing, describing, or citing a violation which is a minor matter. The Team recommends that the OE work with the program offices and the regions to develop additional guidance on what should constitute a minor violation. The program offices, along with the regions and OE, should also develop guidance as to when a violation that meets the threshold for an NCV should be documented in an inspection report.

In addition, to reduce the formality and effort associated with NCVs, OE should review the *NRC Enforcement Manual* and make changes to reduce the effort associated with documenting NCVs in inspection reports. When an inspection report describes an SL IV violation as an NCV, the licensee's corrective action should be briefly described, with a statement that "this licensee-identified and corrected violation is being treated as a non-cited violation, consistent with Section [x] of the Enforcement Policy."

When an NCV involving a minor violation is described in the inspection report, it should be sufficient to state that "this failure constitutes a violation of minor significance and is being treated as a non-cited violation, consistent with Section [x] of the Enforcement Policy. The licensee is required to take appropriate corrective action." It is not necessary to describe the corrective action in the inspection report.

*c. Renaming Non-Cited Violations*

The Review Team considered whether a different term should be given to NCVs to remove any perception of a negative connotation. For a more-than-minor violation, the NRC's issuance of an NCV, rather than an NOV, should generally be viewed as reflecting positive action on the part of the licensee in identifying and correcting it. Although several other terms were considered, the Team believes that the use of "non-cited violation" provides an appropriate balance by emphasizing the value of licensees taking action to identify and correct violations while still recognizing that a legal violation has occurred. A new name has the potential for causing confusion and raising questions as to why the NRC does not want to call a violation a violation. Accordingly, the Team does not recommend a change in this area.

**6. Recommendations**

*a. Recommendations to the Commission*

The Review Team recommends:

II.B-1 That the Enforcement Policy be modified to delete SL V violations, and to provide that formal enforcement action is only taken for violations categorized at or above SL IV. To the extent that minor violations are described in an inspection report, they should be labeled as NCVs. Where a licensee does not take corrective action or repeatedly or willfully commits a minor violation such that a formal response would be needed, the matter should be categorized at least at SL IV.



II.B-2 That the Enforcement Policy be clarified to permit that a licensee not be required to provide a written response to an NOV where, in the staff's judgment, the information normally included in such a response has already been addressed on the docket.

***b. Staff Recommendations***

The Review Team recommends:

II.B-3\* That OE work with the program offices and regions to review the severity level examples in the supplements to ensure that the examples are appropriately focused on safety significance.

II.B-4\* That OE work with the program offices and regions to develop additional guidance to describe the threshold for minor violations. The program offices should also work with the regions and OE to develop guidance on when a violation meeting the threshold of an NCV should be documented in an inspection report.

II.B-5\* That OE review the *NRC Enforcement Manual* to remove unnecessary formality and effort associated with documenting NCVs.

II.B-6\* That the program offices enhance their inspection tracking systems to be able to monitor the number of NOVs issued and the associated number of violations.

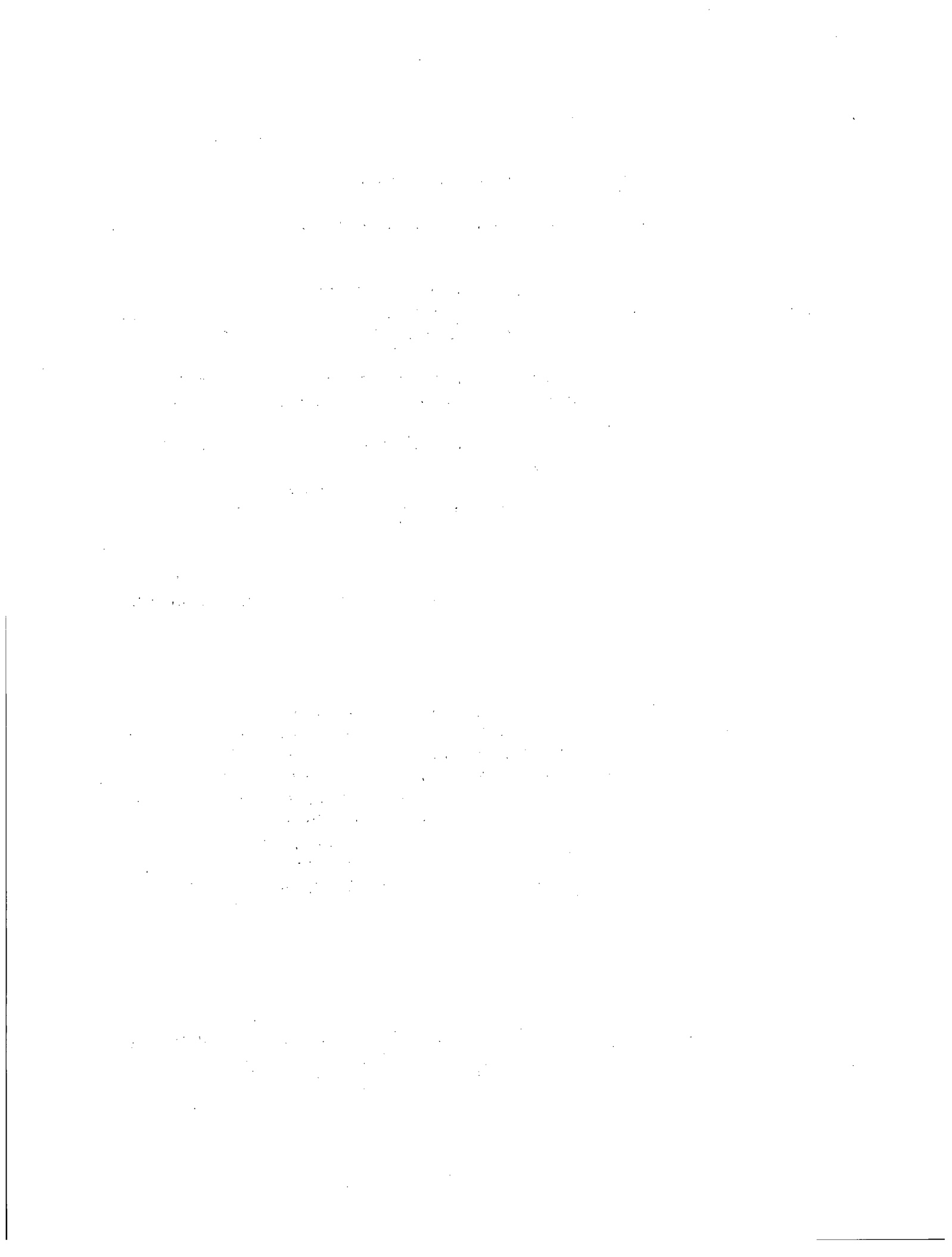

### *Section II.C: Enforcement Conferences*

Issue C of the *Federal Register* notice addressed enforcement conferences, and sought comments on:

- ◆ whether they serve the purposes defined in the Enforcement Policy;
- ◆ benefits and weaknesses of conducting enforcement conferences;
- ◆ whether the licensee's wishes should be considered when deciding whether to hold an enforcement conference;
- ◆ whether the current criteria for holding an enforcement conference are appropriate;
- ◆ whether the NRC should continue to issue inspection reports addressing apparent violations before enforcement conferences;
- ◆ whether the NRC should continue to hold most enforcement conferences in the regional offices rather than near licensed facilities;
- ◆ whether enforcement conferences should be open to public observation; and
- ◆ whether Demands for Information (DFIs) would be a viable substitute for enforcement conferences.

Section II.C.1 discusses the purpose and use of enforcement conferences. Section II.C.2 addresses the issue of open enforcement conferences, and discusses where enforcement conferences should be conducted.

#### *1. Purpose and Use*

Section V of the current Enforcement Policy provides that when the NRC learns of a potential violation for which escalated action may be warranted, the NRC normally provides the licensee an opportunity for an enforcement conference prior to taking the enforcement action. Although enforcement conferences are not normally held for SL IV violations, they may be scheduled if increased management attention is warranted (e.g., if the violations are repetitive). The purpose of the enforcement conference is to (1) discuss the violations, their significance, the reason for their occurrence, including the apparent root causes, and the licensee's corrective actions, (2) determine whether there were any aggravating or mitigating circumstances, and (3) obtain other information that will help the NRC determine the appropriate enforcement action.

##### *a. Summary of Comments*

Although most commenters considered enforcement conferences valuable meetings to ensure the NRC fully understands the facts and circumstances of potential violations and associated corrective actions, many commenters believed that recent NRC practice

in conducting these conferences is not consistent with the stated purposes and objectives. These commenters stated that conferences have moved away from being candid meetings to gather and exchange information, and have become formal meetings to restate pre-existing positions. Many commenters questioned the value of having a conference when the facts and positions of both parties are already known or the issues already addressed.

Some commenters felt that conferences have focused more on NRC emphasizing the significance of issues and the need for effective corrective action. These commenters were concerned that this use of conferences for "management emphasis" implies a level of prejudgment that should follow, not precede, the enforcement conference. Commenters further questioned the appropriateness of conducting enforcement conferences to discuss management concerns, broad performance issues, or policy issues, or to "suggest" improvements to licensee programs where such improvements are not required by regulation.

Many commenters also stated that the threshold for conducting enforcement conferences is too low. Several expressed their concern that inspectors and managers force-fit observations into vague concerns to justify conducting enforcement conferences. Commenters provided various criteria for when enforcement conferences should be conducted, including when issues have real safety significance, when the NRC has sufficient information to conclude that escalated action is highly likely, when a CP will likely be issued, or when violations are contested.

A major concern expressed regarding enforcement conferences was that they pose a major expense and resource burden to licensees and distract in a way that could impact plant safety. This concern was especially important for commenters who felt that many conferences were not necessary to gather information or were not being conducted for issues of real safety significance.

The overwhelming majority of commenters believed that a written summary of NRC concerns was necessary to provide licensees sufficient notice to prepare for enforcement conferences and to take and plan appropriate corrective actions. Commenters also expressed their concern that existing scheduling practices impact conference usefulness. Commenters stated that the 1-2 weeks that licensees are given from the end of an inspection to complete inquiries on facts, assess root causes, reach consensus, develop corrective action, and prepare detailed, accurate enforcement conference presentations is much less time than the NRC takes to judge issues.

Many commenters proposed alternatives to the existing practice of conducting

enforcement conferences. As previously stated, some felt the threshold for holding a conference should be raised. Many suggested using earlier and less resource-intensive information-gathering techniques (e.g., smaller management meetings or conference calls) when safety significance is unclear or the facts complex. Others proposed delaying the inspection exit and including NRC management participation to precisely define the reasons for considering escalated action. Inspection reports would subsequently be issued, licensees would respond to the inspection reports, and any escalated enforcement action would occur after the licensee's response. Some commenters proposed issuing proposed enforcement actions with inspection reports, providing meaningful time for licensee preparation, and providing for a non-adversarial exchange of information at enforcement conferences that would be predecisional to any final enforcement action.

One commenter suggested that the NRC use enforcement conferences in a manner similar to the Environmental Protection Agency (EPA) or the Federal Aviation Administration (FAA). This commenter suggested using *informal* conferences either before or after a Notice of Violation (NOV) is issued (in a manner similar to that of FAA), subsequently allowing compromise and possible CP settlement with no NOV (like FAA), and reserving formal enforcement conferences for contested violations as a means of providing a final opportunity for finding a common ground before going to a formal hearing.

**b. Discussion**

Enforcement conferences have traditionally been viewed as an important part of the Commission's enforcement program. They allow NRC management to deal directly with licensee management on issues that may represent cause for significant regulatory concern. The NRC practice has been generally to conduct these conferences before issuing escalated enforcement action. In doing so, the agency ensures that it has sufficient information to make an enforcement decision, and provides licensees an opportunity (*before* they are subjected to significant enforcement actions) to present their views directly to senior NRC management on the circumstances of a particular case. This presentation may include whether the licensee believes the violation exists, why or why not, what they believe the significance to be, what corrective actions they have taken or believe are warranted, and any other information they believe the agency should consider before making its final enforcement decision.

This meeting also provides licensees an opportunity to identify any errors in the NRC's inspection report or issues that warrant clarification. At times, following the conference additional inspection or investigation is conducted to resolve factual issues

raised during the conference. As a result, NRC enforcement actions, when disputed, tend to focus on regulatory issues and significance and not factual disputes.

Because enforcement conferences have routinely been conducted in the preliminary stages of the enforcement process, the agency has emphasized that the decision to hold a conference does not mean that the agency has concluded that a violation has occurred or that enforcement action will be taken. On the other hand, while conferences are intended to gather facts or clarify information, the general agency practice has been to have sufficient information before the conference to believe that escalated action may be warranted.

**(1) *Uses Other Than Fact-Finding***

A major contention of some commenters was that the agency was using enforcement conferences, not to gain information, but to restate pre-existing views. Many commenters questioned the value of enforcement conferences when the facts and positions of both parties were already known or the issues already addressed. In considering this view, the Review Team observes that although current staff guidance states that the NRC may refrain from conducting a enforcement conference (provided that the NRC has enough information to determine the appropriate enforcement action, the licensee understands the NRC's concerns, and appropriate corrective action has been taken or planned), standard agency practice is that conferences are *normally* conducted. The Team believes that enforcement conferences should be conducted only when necessary.

Another major comment was that the NRC appeared to use enforcement conferences beyond their stated purposes, to emphasize the significance of issues and the need for effective corrective action. The Review Team notes that this use of conferences is not included as a stated purpose in the current Policy; the Team believes, however, that such discussions are within the general purpose of the conference (i.e., to discuss the significance of the violation). Enforcement conferences provide NRC senior management the opportunity to directly emphasize to licensee senior management the agency's preliminary views on the significance of the violations and the need for lasting corrective action. The purpose of the conference, in the Team's view, is not to lecture the licensee; however, certain situations may warrant a candid face-to-face dialogue to ensure that the licensee understands the NRC's cause for (and level of) concern.

**(2) *Threshold of Significance for Holding a Conference***

Tables F-1 and F-2 provide information on the number of conferences in the reactor and materials area. The tables also show the outcome of the conferences. In the past 2 years, about 70% of the conferences resulted in escalated enforcement action. The Review Team believes that enforcement conferences should be considered only when it is reasonably expected that escalated enforcement action will be subsequently issued. In other words, enforcement conferences should not be conducted to address issues that would not reasonably be categorized at SL III or higher. Similarly, enforcement conferences should not be conducted for repetitive SL IV violations unless they likely represent a significant regulatory concern (i.e., the agency believes they will likely rise to an SL III).

This threshold should not be interpreted as requiring certainty that the outcome of an enforcement conference will be an SL III or higher action. Enforcement conferences are predecisional, and an SL IV outcome would not necessarily mean that the conference was inappropriate. Enforcement decisions should be made following the conference based on all available information, including that developed in or following the conference, or new perspectives gained as a result of the conference.

**(3) *Criteria for Holding Enforcement Conferences***

The Review Team believes that enforcement conferences should not be viewed as automatic, nor should they be viewed as expected periodic opportunities to recalibrate the NRC-to-licensee relationship. The conference carries with it substantial resource effort for both the licensee and the NRC. To justify that effort, the Review Team believes that enforcement conferences, rather than being held as a matter of standard practice for escalated actions, should be conducted only when necessary. For instance, in a case where corrective action has been taken and the staff is satisfied that the significance and root causes are understood, an enforcement conference may not be necessary. A conference may be redundant in a situation where the staff and the licensee have already exchanged information and views, such as in a public meeting on a restart matter, an Augmented Inspection Team exit meeting, or a management meeting.

The Team also notes that for SL I and II violations, willful cases, or matters involving multiple SL III violations over a relatively short period, there will likely be a need for a common understanding of the root causes, corrective action, and/or significance. As a result, conferences should generally be held for such matters.

The Team recommends that predecisional enforcement conferences be held only when needed to obtain information to make enforcement decisions, such as:

- ◆ a common understanding of facts, root causes, and missed opportunities to identify the violation sooner,<sup>1</sup>
- ◆ a common understanding of corrective actions taken and planned, or
- ◆ a common understanding of the significance of the issues and the need for lasting and effective corrective action.

In addition, a conference may be held if the licensee requests it.

If an enforcement conference is not held, prior to resolving the escalated enforcement matter, the Review Team believes it is appropriate to obtain from the licensee a written response to the inspection report. This response should address corrective action, and should provide an opportunity to dispute inspection findings. Following the receipt of such a document, the decision not to have an enforcement conference may be reconsidered.

#### **(4) *Timeline for Licensee Preparation***

The Team finds it essential that licensees are given enough time to prepare for enforcement conferences. In current practice, a licensee receives the inspection report about 3 weeks after the inspection, and about 1 week prior to the enforcement conference. The Review Team believes that the licensee should receive the inspection report 2 weeks prior to the enforcement conference to allow additional preparation time. Licensees should have adequate time to perform necessary reviews or investigations, develop corrective action plans, and prepare presentations. While licensees are expected to begin their preparation based on the inspection exit meeting, the specific findings or issues of concern may not be fully understood until the licensee has received the written report.

Additional time may be needed to prepare for conferences involving complex issues. The timeliness of the process is also dependent on effective exit meetings. The licensee should be put on notice if, after the exit meeting, the agency concludes that different issues should be the focus of the enforcement conference. This should also be considered in scheduling the conference.

---

<sup>1</sup>See Section II.D.4.d for more discussion on these missed opportunities.



*c. Recommendations*

*(1) Recommendations to the Commission*

The Review Team recommends:

- II.C-1 That the Enforcement Policy be modified to discontinue conducting enforcement conferences for matters categorized at SL IV.
- II.C-2 That the criteria for holding predecisional enforcement conferences be modified to provide that they be held only when needed to obtain information to make enforcement decisions, such as:
- ◆ a common understanding of the facts, root causes, and missed opportunities to identify the violation sooner,
  - ◆ a common understanding of corrective actions, or
  - ◆ a common understanding of the significance of the issues and the need for lasting and effective corrective action.

In addition, a conference may be held if the licensee requests it.

*(2) Recommendations to the Staff*

The Review Team recommends:

- II.C-3\* That the staff revise existing guidance to provide licensees with the inspection report normally 2 weeks in advance of an enforcement conference.

*2. Open Enforcement Conferences*

Section V of the current Enforcement Policy states that, "enforcement conferences will not normally be open to the public." However, on July 10, 1992, the Commission established a 2-year trial program to determine whether the Policy should be changed to make most enforcement conferences open to attendance by the public. On July 19, 1994, the Commission announced that the trial program would be continued until the Commission had acted on the Enforcement Review Team's recommendations.

Appendix F includes a copy of the original *Federal Register* notice announcing the trial program. The policy statement explained that the Commission's decision on whether to

establish a permanent policy for making enforcement conferences open would be based on an assessment of the following criteria: (1) whether the fact that the conference was open impacted the NRC's ability to conduct a meaningful conference and/or implement the NRC's enforcement program; (2) whether the open conference impacted the licensee's participation in the conference; (3) whether the NRC expended a significant amount of resources in making the conference public; and (4) the extent of public interest in opening the enforcement conference.

Under the trial program, approximately 25% of all eligible enforcement conferences were open to public observation. Open enforcement conferences were conducted in each regional office, and were conducted with various types of licensees. Eighty-seven conferences were open during this period. Members of the public attended 43% of these open conferences. In most cases, three or fewer members of the public attended. Appendix F includes statistics on enforcement conferences.

*a. Summary of Comments*

This section summarizes comments solicited from (1) the open enforcement conference trial program, (2) this enforcement program assessment, and (3) staff surveys conducted during the trial program.

*(1) Summary of Comments From the Trial Program*

The NRC first solicited comments on the issue of conducting open enforcement conferences when it originally announced the trial program on July 10, 1992. The *Federal Register* notice stated that comments could be submitted on or before the completion of the program, and the policy statement noted that persons attending open conferences would be provided an opportunity to submit written comments anonymously. The NRC received about 20 responses on the trial program, including comments from licensees, State and local governments, members of the media, members of interested citizen groups, and members of the public.

Because the NRC did not solicit comments on specific questions regarding the trial program (such as whether the program should be made a permanent policy), comments covered a range of issues. Several commenters addressed issues related to the four criteria identified in the trial program policy statement, while other commenters addressed issues such as open conference selection criteria, notification, location, and opportunities for public education and input.

Some commenters believed that more senior-level NRC managers attended open

conferences regardless of the severity level of the apparent violations, and questioned whether this was an efficient use of NRC resources. These commenters were also concerned that public attendance makes the NRC feel compelled to be a "tough regulator," regardless of the significance of the issues, and that the NRC staff may be less forthcoming or direct in its views because of the presence of observers.

Several licensees commented that they believed the information they had conveyed in open enforcement conferences was of the same quality and quantity as if the conferences were closed, while others commented that open conferences may inhibit a frank and candid exchange of information and may reduce a licensee's willingness to verbally admit violations or commit to corrective actions.

Many licensees commented that open conferences (and particularly the associated presentations) have taken significantly more time and effort, consuming resources better applied to safety issues. Licensees commented that they are motivated to take additional actions because of the concern that the media will provide an inaccurate or unbalanced view of the discussions and issues at open enforcement conferences. Several commenters observed that the NRC seems to have spent additional time preparing for these conferences for much the same reasons. In some instances, commenters reported that more NRC personnel attended open conferences than had attended closed conferences.

Many commenters noted that public attendance at open enforcement conferences has been negligible. Some stated that the relatively slight public interest in attending these conferences reinforces a conclusion that the public is adequately served by communicating enforcement actions and their basis through other NRC channels currently in place. Other commenters stated that despite low attendance, open enforcement conferences provide the public an opportunity to hear firsthand the background, associated dialogue, root causes, and corrective actions, and licensee and NRC positions on important issues.

One commenter stated that the criteria for having a closed enforcement conference should be expanded to include situations in which the licensee determines that a particularly knowledgeable individual should attend the conference. The comment was based on the concern that an individual may not be accustomed to the stressful conditions of public speaking and that it may not be fair to hold such an individual under public scrutiny. Consequently, the commenter stated that a licensee should be allowed to participate in the decision of whether a conference is to be open or closed. Another commenter stated that, because of the potential for public

confusion or premature conclusions in certain cases, the NRC should revise its selection criteria to only consider routine enforcement matters as appropriate subjects for open conferences.

One commenter found the NRC's current methods of providing notice on open conferences to be inadequate, and stated that the NRC should consider direct mailing of upcoming conferences to interested citizens (based on pre-registration). Several commenters recommended providing more advanced notice of open enforcement conferences. Two commenters attending the same conference noted that the associated press release included incorrect information.

Several commenters addressed the issue of where open enforcement conferences should be conducted. One commenter stated that the NRC should maintain its practice of holding conferences in the regional offices. The commenter stated that the minimal interest evidenced doesn't justify the added expense for the NRC to conduct local conferences, and that it would be a poor use of license fee dollars. On the other hand, many commenters supported having the NRC hold open enforcement conferences in the vicinity of the licensee.

One commenter suggested several ways to educate the public and the media, to overcome the inherent potential that licensees (and individual licensee representatives) will be prejudged as guilty simply because the conference is being held. The commenter suggested that the NRC educate attendees at open enforcement conferences in terms of the meaning and purposes of open conferences, and remind attendees that the "apparent violations" being discussed are subject to review and may change prior to any resulting enforcement action. The commenter further suggested that the NRC subsequently mail the attendees a summary of the conclusions and their bases in the event the NRC issues an enforcement action that varies significantly from the issues discussed at an open enforcement conference. Several commenters suggested that the NRC allow observers to provide input at the end of open enforcement conferences.

Comments were mixed on whether open enforcement conferences should be adopted as a permanent policy. Some commenters supported making all conferences open, based on the public benefit and the view that open enforcement conferences are more likely to produce positive results because licensees are more likely to maintain compliance when they are subject to public scrutiny. Other commenters did not favor making all enforcement conferences open, based on concerns that open conferences would or could inhibit a frank and candid exchange of information, and that the lack of public interest does not justify the added

expenditure of NRC and licensee resources. One commenter suggested that if the NRC would like to maintain some openness in the process, it should at most hold only a small fraction of all conferences as open conferences.

**(2) *Summary of Comments From This Enforcement Assessment***

Section C.7 of the August 1994 *Federal Register* notice solicited views on open enforcement conferences, including whether they affected either the NRC's conduct or licensees' participation during the conferences, whether they impacted the licensees' costs, whether the public benefited from them, whether they should be transcribed, whether the NRC (or the public) should be able to participate in them by telephone, and, ultimately, whether open conferences should be made a permanent policy.

The overwhelming majority of commenters stated that open enforcement conferences have either affected or have the potential to affect the NRC's conduct or licensees' participation during the conferences. Although none cited specific examples to support their remarks, commenters stated that open enforcement conferences limited frank and open discussions, that NRC questions were more formal and less probing, and that open enforcement conferences were less productive than closed enforcement conferences.

All of the commenters stated that making enforcement conferences open impacted their cost of participation. Commenters observed that the extra time, expense, and management effort in preparation for the conference, the fact that licensees were simplifying their presentations for the benefit of the public and media, and the fact that licensees felt compelled to send legal, public relations, and other staff to the conference because of the possibility of public attendance. Commenters were concerned that technical issues would need to be simplified to ensure public and media understanding. One commenter based the extra cost on the fact that the licensee would likely be incurring the cost of State personnel travel.

As to whether the public benefited from the ability to observe enforcement conferences, a few commenters said yes, while most said no. Commenters stated that open enforcement conferences have not been well attended, that enforcement conferences normally include complex technical issues with no provisions for educating the public or media on the issues, and that enforcement conferences have not been scheduled at times convenient to public attendance.<sup>2</sup>

---

<sup>2</sup>See Appendix F for statistics on attendance at open enforcement conferences.

Although a few commenters supported transcribing open enforcement conferences and subsequently making them publicly available as an alternative to conducting open conferences, most commenters did not favor transcribing open enforcement conferences. The bases for the comment included that transcriptions would further constrain communications, that they would chill candor, that they could cause the NRC and licensees to become more defensive and less open to new information, that they could be misinterpreted and taken out of context, and that they would serve little purpose.

With regard to NRC participation in open enforcement conferences by telephone, some commenters stated that NRC Headquarters' participation should not affect whether an enforcement conference is public. Some commenters stated that the NRC should be allowed to use any means to collect and understand information provided by licensees, that telephone participation was a better use of resources, and that telephone participation might be appropriate for discussing minor issues. Several commenters noted the limitations of telephone participation in that telephone participants would not be able to view written materials.

Most commenters did not favor allowing the public to listen to open enforcement conferences by telephone, based on the view that public attendance by telephone would have the same negative impact as public attendance in person. Some commenters stated that public access by telephone would be preferable to no access, but that public attendance would be better. Others supported allowing the public to listen in when an enforcement conference is conducted by telephone. Some commenters mentioned that, if the public listened in by telephone, it should not be at the NRC's or licensee's expense.

The majority of commenters did not favor making open enforcement conferences a permanent part of the Enforcement Policy. The bases given for this view included that open enforcement conferences could inhibit candid discussion of technical issues not easily presented to lay-persons, that the media could take things out of context and cause misrepresentations, that enforcement conferences should be informal meetings to exchange information solely between the NRC and licensees, that many licensees may not attend open enforcement conferences and instead request hearings (causing inefficiency and increased cost), that the public and media would tend to prejudge the licensee as guilty, that open enforcement conferences could impact an individual's reputation and career before the NRC has made a final enforcement determination, and that the added expense does not justify the purported benefit of public observation, since the public has shown little interest.

Some commenters that favored open enforcement conferences stressed that the public must be able to participate, observe, and learn the NRC rationale for mitigation. Commenters stated that closed enforcement conferences imply an NRC/licensee compromise. One commenter stated that open enforcement conferences were beneficial because they provided an opportunity for the public and other agencies to assess the significance of enforcement issues, rather than depending on sensationalized media versions. Another suggested that, if open conferences were discontinued, the NRC should still allow State or local regulator attendance.

Several commenters also addressed issues regarding open enforcement conference notification, adverse publicity prior to the issuance of enforcement actions, and opportunities for public input. One commenter stated that open conferences need more notice of the meeting and of possible cancellations. One commenter expressed the concern that enforcement conferences become enforcement actions in and of themselves when they are publicized or open to the public because the media and the public will prejudge licensees as guilty. The commenter suggested that the NRC enforcement program should not lead to an NOV or adverse publicity until completion of the process. Another commenter stated that anyone present should be able to present a prepared statement at an enforcement conference for NRC consideration.

### *(3) Summary of Comments From Staff Surveys*

To help assess issues related to the four criteria in the open enforcement conference policy statement, the staff developed an internal survey. These surveys were completed after each open enforcement conference.

A strong majority of staff responses indicated that conducting open enforcement conferences did not impact the NRC's ability to conduct meaningful conferences and/or implement the NRC's enforcement program. An overwhelming majority also indicated that conducting open enforcement conferences did not impact licensees' participation in enforcement conferences. The staff observed little or no difference in the candor and manner of communications with licensees, and found that most licensees were freely admitting violations and thoroughly explaining root causes.

The staff indicated that the agency had expended additional resources during initial stages of the trial program (based on extra staff preparation, additional staff attendance, and special equipment purchases). As experience was gained in

conducting open enforcement conferences, however, the staff indicated that this resource expenditure lessened. Staff comments did indicate that open enforcement conferences frequently increased demands on the agency's public affairs staff (based on associated press releases and attendance).

Finally, staff responses indicated that open enforcement conferences have not been widely attended by members of the media or members of the public.

***b. Discussion: Continuation of Open Enforcement Conferences***

The NRC has a longstanding practice of conducting business in an open manner, providing the public with the fullest information practicable on its activities while balancing the need for the NRC staff to exercise its regulatory and safety responsibilities without undue administrative burden.<sup>3</sup> Enforcement conferences have traditionally been closed meetings between the NRC and licensees to exchange information regarding potential safety issues. The trial program was intended to evaluate whether that practice should be changed.

***(1) Inhibiting Communications***

The most significant concern in allowing public observation at enforcement conferences is that open conferences could inhibit open and candid discussions between the NRC and licensees, limit the free exchange of information, and thereby reduce conference effectiveness and negatively impact the effectiveness of the enforcement program. Before the trial program was implemented, this concern was shared by the regulated industry as well as by many NRC staff and managers.

Although many industry commenters continued to reiterate this concern, the Review Team does not find that open enforcement conferences conducted during the trial program were substantially less frank and open, nor was the NRC prevented from obtaining the information required to implement its enforcement program. The staff did indicate, in certain cases, the need to ask licensees additional questions, but the information ultimately provided was always sufficient to meet enforcement conference goals. Several licensees also commented that the

---

<sup>3</sup>The Review Team recognizes that having highly technical meetings open to the public exposes participants to the risk that information may be misunderstood or misconstrued; however, the Team does not find that risk to be of sufficient concern to outweigh the public confidence gained by allowing open observation of NRC enforcement conferences. Public observation at NRC meetings is the normal policy of the agency ("Staff Meetings Open to the Public; Final Policy Statement," 59 FR 48340, September 20, 1994).



information they had conveyed in open enforcement conferences was of the same quality and quantity as if the conferences had been closed.

**(2) *Additional Resource Demands***

The Review Team considered licensee concerns regarding the added expense of conducting open enforcement conferences. The intent of making enforcement conferences open is not to make the process more expensive for licensees, nor to divert resources from safety issues. Although the Team recognizes licensees' motivations regarding enforcement conference presentations, licensees should keep in mind that the NRC is the audience to whom they must convey information.

The NRC must also be careful to balance providing public opportunities for observation of the regulatory process against the need to exercise its regulatory and safety responsibilities without undue administrative burden. Although some additional resources were spent initially, the Review Team finds that the long-term resource impact of the trial program was nominal. To manage the impact on agency resources, the Review Team recommends that, if adopted, open enforcement conferences be conducted similar to other open meetings and similar to previous practices for enforcement conferences (see the discussion on "Conduct of Open Enforcement Conferences," below).

**(3) *Conclusion***

Although open enforcement conferences were not widely attended during the trial program, the Team believes that opening enforcement conferences is consistent with the agency's principles of good regulation. The intent of open conferences was not to maximize public attendance, but rather to provide the public with an opportunity to observe the regulatory process publicly and candidly.

After considering the impact on the NRC's ability to exercise its regulatory and safety responsibilities, the impact on the candor and openness of communications during enforcement conferences, the impact on NRC resources, and the benefit to the public, the Review Team recommends that the Enforcement Policy be modified to provide that most enforcement conferences be open to public observation. While, as for any public meeting, the NRC retains the discretion to close the conference for a specific case, the Review Team believes that the criteria for closing enforcement conferences addressed in Section I of the trial program policy statement are normally sufficient.

The Team also recommends that the Policy be clear that enforcement conferences are open for public observation and not participation. This is consistent with the agency's policy on open meetings.

*c. Conduct of Open Enforcement Conferences*

To manage the impact on agency resources, the Review Team recommends that open enforcement conferences be conducted similar to other open meetings and similar to previous practices for enforcement conferences. These provisions include: (1) using notification mechanisms already in place for open meetings, (2) normally holding conferences in the regional offices, (3) allowing limited staff participation by telephone, and (4) not requiring the NRC to routinely transcribe or tape-record open conferences. These four issues are addressed below.

*(1) Notification for Open Enforcement Conferences*

On September 20, 1994, the NRC published its final policy statement on staff meetings open to the public (59 FR 48340). As part of the policy statement, the NRC established mechanisms for public notification, including a toll-free telephone recording, a toll-free electronic bulletin board, weekly distribution of public meeting announcements to the press, and posting meeting announcements in the NRC PDR. The Review Team believes that these mechanisms provide sufficient notice to the public for open meetings, and should, therefore, provide sufficient notice for open enforcement conferences. Although direct mailing (as one commenter suggested) could provide interested citizens with direct notification, it would impose too great an administrative burden on the agency.

Further, the Team believes that the public has a responsibility to take action to access available information to decide if they are interested in attending a particular enforcement conference. The Team also believes that providing 10 days notice (consistent with the current policy on open meetings) provides sufficient notice to the public. Providing more notice (as several commenters suggested) would impact the agency's responsibility to implement the enforcement program in a timely manner.

During the trial program, notification was also provided by the press releases announcing open conferences. For additional discussion on whether press releases should be continued, see Section II.C.2.e, below.

### **(2) *Location of Open Enforcement Conferences***

Enforcement conferences have routinely been held in the regional offices. Although holding open enforcement conferences near licensed facilities could provide individuals with a greater opportunity to observe the agency's regulatory process, the Review Team believes that doing so would impact the agency's ability to carry out its regulatory and safety responsibilities and create a resource burden. The NRC may conduct over 100 enforcement conferences in a year. Conducting enforcement conferences near licensed facilities would have a significant impact on NRC resources, both in the time spent in travel by NRC managers and inspectors and in the related costs. The NRC could also be burdened with the cost of securing a facility to conduct certain enforcement conferences.

The Review Team notes that the purpose of conducting open enforcement conferences is not to maximize public attendance, but rather to provide the public the opportunity to observe how the NRC conducts this phase of the enforcement process, while balancing the need for the NRC staff to exercise its regulatory and safety responsibilities without undue administrative burden. The Review Team believes that a practice of normally holding open enforcement conferences at the regional offices meets this objective.

### **(3) *Telephone Participation and Telephone Conferences***

Enforcement conferences have also routinely included Headquarters staff participation by telephone. This practice was established to control agency resources while providing agency-wide perspectives on enforcement issues, thereby enhancing the NRC's ability to efficiently and effectively implement its enforcement program. Given the agency benefit, the Team believes that it is appropriate to allow Headquarters staff participation by telephone for open enforcement conferences. Telephone participation is enhanced by ensuring that written materials and handouts are faxed to Headquarters participants.

The Review Team also believes that enforcement conferences should not be open if they are being conducted exclusively by telephone. This is consistent with the definition of a public meeting in the Commission's policy statement on open meetings, and with the current practice during the trial program.

Although allowing public observation by telephone would increase the opportunity for the public to observe the regulatory process, the Team questions whether it would represent a meaningful opportunity. Many enforcement conferences involve

technically and scientifically complex matters that would be difficult for the general public to follow during a telephone conference call. Observation by telephone would be further limited because written materials would not be available to the public and the public would not be able to easily distinguish between NRC and licensee speakers. The quality of the telephone communications may compound the difficulty of following the discussions. Moreover, providing for public observation by telephone could be disruptive to enforcement conference proceedings and could present an administrative burden. The Team believes that allowing public observation when conferences are held in the regional offices provides a sufficient opportunity for the public to observe the enforcement process.

**(4) *Transcribing or Tape-Recording Open Enforcement Conferences***

The Review Team also believes that enforcement conferences should not routinely be transcribed or tape-recorded. Enforcement conferences have not normally been transcribed unless the agency believes that circumstances warrant a written record (e.g., the case involves a potential wrongdoing issue, or action against an individual). The Team believes that transcribing (or tape-recording) all enforcement conferences would represent an administrative burden without a commensurate benefit. Current mechanisms are already in place to notify the public of the outcome of enforcement conferences, by placing enforcement conference summaries and enforcement actions in the PDR. The Review Team also notes that for normal cases, the agency has been able to implement its enforcement program without the use of transcriptions or tape recordings.

The NRC began the practice of tape-recording open enforcement conferences as a precautionary measure to ensure that the agency had its own record of proceedings in the event a licensee or member of the public recorded an open enforcement conference and subsequently referenced it. This practice has become an administrative burden both in equipment purchases and in the effort of making the recordings available in the PDR. The Team notes that the tape-recordings from open conferences have seldom been used in the enforcement process. Moreover, the Team believes that if an agency record is required, then a transcript should be used instead of a tape-recording. The Team recommends that the practice of tape-recording open enforcement conferences be discontinued.

**d. *Treating Enforcement Conferences as Predecisional***

A major reason why licensees did not support open enforcement conferences was their concern that the public and the media would consider licensees "guilty" simply by

participating in enforcement conferences. Licensees expressed their concern that, despite the fact that the agency has not yet issued an enforcement action, the open enforcement conference becomes an enforcement action in itself because of the associated publicity.

The Review Team agrees that enforcement conferences should be viewed as predecisional. While it is true that the decision to hold an enforcement conference generally means that the staff believes escalated enforcement action may be warranted, the final decision has yet to be made.

In view of making enforcement conferences open, the Team believes it is important that NRC emphasize the meeting's predecisional nature as an early evaluative stage in the enforcement process. Based on past data, up to 30 percent of enforcement conferences do not result in escalated enforcement action. Accordingly, the Review Team recommends that the *NRC Enforcement Manual* guidance continue to require that the staff acknowledge and emphasize the preliminary nature of enforcement conferences, and that the apparent violations being discussed are subject to review and may change prior to any resulting enforcement action.

In addition, the Team recommends that enforcement conferences be renamed "predecisional enforcement conferences." The Team believes that the use of this term in the Enforcement Policy, public announcements, and licensee correspondence will emphasize that the plan to hold an enforcement conference does not mean that a violation has occurred or that escalated enforcement action will be taken.

*e. Use of Press Releases to Announce Open Enforcement Conferences*

During the trial program, press releases were normally issued for open enforcement conferences, and typically highlighted the fact that the enforcement conferences were open as part of a trial program. Both before and during the trial program, press releases were not issued for closed enforcement conferences. In recommending that the open enforcement conference policy be made permanent, the Review Team believes that the use of press releases for open enforcement conferences should be reconsidered (see also the discussion of publicity in Section II.A.6.b).

At the outset, the Team notes that the NRC's Office of Public Affairs (OPA) strongly supports continuing to use press releases for open enforcement conferences, for several reasons. First, OPA would characterize the open enforcement conference as a significant NRC action, and therefore a matter on which the Commission should inform the public. Secondly, a press release should not be viewed as an instrument of

enforcement, but rather as an effort to build and retain credibility with the public (again, by providing helpful information on significant NRC action in the public domain). Thirdly, a "bare-bones" notice in the PDR and electronic bulletin boards will not reach most reporters or interested members of the public, which in OPA's opinion belies the concept of an "open" conference. Finally, since the PDR and bulletin boards are monitored by anti-nuclear groups who might be expected to issue their own press releases, OPA feels that the resultant publicity would in many cases be negatively skewed.

The Team discussed this issue at length. The Team agrees that press releases are appropriate for significant NRC actions. In the Team's view, however, enforcement conferences are not of themselves significant agency actions, but rather are *predecisional* to what may later result in a significant agency action. For comparison, the Team observes that press releases are characteristically made at the time an NOV with CP is issued, but are *not* made when an NOV of the same severity is not accompanied by a CP. This distinction is made based on the relative significance of the two actions; from this line of reasoning, issuing press releases for open conferences suggests that the predecisional conference itself may be more significant than the resulting enforcement action. The Team notes again that many conferences do not result in CPs, and some do not even result in enforcement action (see the Appendix F data).

Moreover, the publicity associated with issuance of significant enforcement actions has traditionally been viewed as reinforcing the action itself. While the Team agrees that the press release should not be viewed as an instrument of enforcement (i.e., it is not intended to serve as a sanction), the Team also notes that both large and small licensees view the negative publicity and attention resulting from the press release as having a greater impact than the financial impact of the CP. The NRC believes that licensees will be motivated to identify and correct violations if they believe that the CP will be fully mitigated as a result; that motivation may be increased by the desire to avoid the negative publicity associated with the CP press release. Issuing press releases at the predecisional enforcement conference stage will, in essence, appear to the licensee as if a sanction is being received before the agency has in fact reached an enforcement decision. Thus, to issue a press release at this stage is inconsistent with the predecisional nature of the conference, and may interfere with the incentive system built into the proposed enforcement approach.

The Team also recognizes the contention that, when a press release is issued at various stages of a single enforcement action, the public may often mistakenly interpret each press release to be related to a separate licensee failure. For instance, when a violation

is revealed through an event, a press release might be issued for the event if significant enough. If an Augmented Inspection Team (AIT) is sent to the site, a second press release may be issued to report the AIT findings. If escalated action results, press releases might also conceivably be issued for the conference (if open), for the Proposed Imposition of Civil Penalty (if applicable), and for any later significant revision to the CP action. Depending on the time elapsing between press releases and the clarity of each description, a member of the public might believe that three or four separate problems have occurred. This concern reinforces the Review Team's view that press releases should not be issued for predecisional enforcement conferences.

The Review Team notes again that the reason for conducting open conferences is not to maximize or facilitate public attendance at NRC meetings. Rather the intent is to conduct the agency's business in public, to the extent practical. Based on this understanding, the Team recommends that open enforcement conferences be treated similarly to other open meetings. In other words, open enforcement conferences should normally be announced through existing public meeting notification mechanisms as described in Manual Directive 3.5, Part 2, Section A. Information associated with the conference, such as the conference summary and inspection report, should be made publicly available, as in current practice. Press releases should not routinely be issued for open conferences, but rather issued only when specific issues exist that the agency believes are of sufficient interest to the public, as would occur with other meetings of the NRC.<sup>4</sup> In the event press releases are issued, they should include standard language that acknowledges and emphasizes the predecisional nature of the meeting, and should note that the apparent violations being discussed are subject to review and may change prior to any resulting enforcement action.

As a final observation in this area, the Team recognizes that some may feel that no longer issuing press releases for open enforcement conferences will be perceived as a move toward being less open. The Team disagrees; in fact, this change in practice simply reflects the transition from the open enforcement conference trial program (in which only 25% of conferences were open) to a permanent policy in which conferences are normally open. As such, this change removes the need to distinguish by a press release those conferences that will be open to the public.

*f. Recommendations to the Commission*

The Review Team recommends:

---

<sup>4</sup>For example, press releases are issued for significant Commission meetings on a case-by-case basis only.

II.C-4 That the Enforcement Policy be modified to state that predecisional enforcement conferences will normally be open to public observation, but not to public participation. The Enforcement Policy should also state under what circumstances predecisional enforcement conferences will not be open to the public (i.e., when involving privacy, safeguards, proprietary, and investigational issues).

II.C-5 That the Enforcement Policy be modified to include the following purpose statement for conducting open enforcement conferences:

The purpose of conducting predecisional enforcement conferences in the open is not to maximize public attendance, but rather to provide the public with opportunities to be informed of NRC activities while balancing the need for the NRC staff to exercise its regulatory and safety responsibilities without undue administrative burden.

II.C-6 That open enforcement conferences be announced using existing notification mechanisms. The practice of issuing press releases for open conferences should be discontinued.

II.C-7 That the practice of taping open enforcement conferences be discontinued.

II.C-8 That enforcement conferences be renamed "predecisional enforcement conferences."



---

*Section II.D: Civil Penalties***1. Background and Summary of Comments**

Issue E of the *Federal Register* notice addressed the NRC's use of civil monetary penalties (CPs) as an escalated enforcement sanction. The authority to issue CPs is rooted in Section 234 of the AEA. CPs are intended to emphasize the need for lasting remedial action, and to deter future violations both by the licensed party and by other licensees conducting similar activities.

As discussed in Appendix D, the use of CPs has evolved with NRC experience, with changes occurring in the maximum CP amount authorized by statute, the use of discretion in escalating and mitigating CPs, and the weight of various factors used to determine the appropriate value for a given CP. In a recent NRC study, the Review Team for Reassessment of the NRC's Program for Protecting Allegers Against Retaliation recommended that the CP statutory authority be increased to \$500,000. The Commission deferred making a decision on the increased CP authority related to allegation issues, asking instead that the Enforcement Review Team study CP increases in an overall enforcement context and provide the Commission with a recommendation.

In the area of CPs, the Review Team sought comments on:

- ◆ whether the NRC should continue to use CPs, and, if so, how and when;
- ◆ whether the Commission should seek higher CP authority, to increase the compliance incentive, to account for inflation, and/or to consider processing and investigative costs;
- ◆ whether the CP amount should be based solely on a violation's occurrence (i.e., as opposed to considering the surrounding circumstances, such as licensee responsiveness and the violation's root cause);
- ◆ whether the NRC should continue to use the current CP adjustment factors, eliminate certain factors, add new factors, or weight various factors differently;
- ◆ whether more or less flexibility in arriving at CP amounts would improve their overall application, and whether the delegation of CP decisions should be increased; and
- ◆ whether the current categories of base CP amounts, based on licensee type, potential hazard, and violation severity level, should be reclassified.

Nearly all commenters felt that the NRC should continue to use CPs, but opinions differed as to how and when. Many industry responses indicated that CPs provided only a minimal deterrent effect, because other pressures (such as economics, adverse publicity, and professionalism) already provided forceful motivations to maintain safety and compliance.

Most of these commenters felt that the use of CPs should be considerably reduced--for example, by reserving CPs for matters involving actual safety consequence (i.e., events threatening public health and safety) or for violations involving willfulness. Several respondents felt that, rather than collecting a CP, the NRC should order the licensee to spend equivalent funds in specific ways that would contribute to safety.

On the issue of whether CPs should be higher, many commenters from industry emphasized that no correlation had been demonstrated between higher CPs and an increased licensee commitment to safety; as a result, these responses favored either lowered CPs or keeping the status quo. One such respondent stated that any increase in CP amounts should be linked to better NRC discipline in basing violations on facts and meeting burdens of proof. Several industry commenters stated that higher CPs could increase the potential for litigation, or could actually discourage self-identifying and reporting violations. One commenter suggested that higher penalties could be achieved simply by fully implementing the current assessment factors (e.g., *Duration*).

By contrast, several commenters supported increasing CPs for specific types of violations (e.g., those involving discrimination or willfulness). Two commenters felt that CPs should be increased to account for inflation, and one stated that the CP increase should be based on making compliance more financially attractive than non-compliance. Little support existed for tying CPs to processing and investigative costs, and one response pointed out that a more simplified process would reduce those costs.

Only one respondent favored using a fixed CP for certain violations (i.e., not considering the surrounding circumstances). Most felt that other factors, such as *Identification*, *Corrective Action*, and the root cause, should be considered in assessing a CP. Although some favored escalating or mitigating based on various factors, most commenters agreed that the existence of the CP itself was more important than adjustments in the actual amount.

Although comments varied as to how each CP adjustment factor should be treated, many commenters felt that the current factors were too heavily weighted toward escalation (total possible 500% above the base CP) versus mitigation (total possible 200% from the base CP). Respondents generally favored a heavy emphasis on self-identification and corrective action, and most felt that prompt, comprehensive corrective action should override other considerations. Several stated that the NRC definition of "self-disclosing," as applied to an event or violation, should be clarified, and that the current application of the Policy was reluctant to give licensee credit for self-disclosing issues.

The response on other factors was mixed. Commenters disagreed on how and when a

licensee's past performance should be considered an escalating or mitigating factor, but one commenter noted that the NRC's inconsistent use of this factor decreased its effectiveness. Two commenters stated that the application of *Duration* should be maximized; others felt that *Duration* should only be applied based on an increase in risk or licensee knowledge of the violation. Opinions differed on whether reporting a violation should be a factor considered in CP assessment.

Few respondents commented on the need for more or less flexibility in applying the CP adjustment factors, but comments elsewhere (responding to Section A of the *Federal Register* notice) strongly favored measures to improve the consistency and predictability of the enforcement program. In general, those comments encouraged more centralized review of enforcement decisions based on the severity of the sanction. Nearly all commenters opposed further delegation of escalated enforcement actions to Regional Administrators or below.

Few responses addressed the questions on whether the current categories of base CP amounts should be reclassified. One commenter felt that the divisions should be made according to radionuclide hazard and activity level. Two others stated that CP amounts should consider a licensee's ability to pay.

## 2. *Purpose and Philosophy of Civil Penalties*

As many of the commenters suggested, and as discussed in Section II.A, avoiding escalated NRC enforcement action is only one among many motivations for compliance in the nuclear industry. When a violation occurs, however, the other motivations have not been sufficient. At such times, the appropriate NRC enforcement action, applied with discretion and judgment, can provide an additional effective deterrent against future violations, by: (1) emphasizing the importance of adherence to requirements; and (2) reinforcing those aspects of licensee performance that are especially crucial in ensuring quality (e.g., self-identification of problems and root causes, prompt and comprehensive correction of errors, and recognition and avoidance of adverse trends).

The Review Team discussed extensively the purpose and philosophy of CPs as they fit into the overall context of the NRC enforcement program. Within that program, the CP exists as a flexible sanction for providing appropriate emphasis and deterrence. The CP clearly provides more of a negative incentive than just an NOV, but stops short of more extreme

measures such as license revocation or suspension.<sup>1</sup> To be effective, a CP should be financially relevant (but not financially crippling),<sup>2</sup> the message it is intended to reinforce should be focused and clear, and the range of CPs available must be wide enough both to differentiate between the significance of different violations and to apply to the full gamut of licensees.

As to using CP funds in alternate ways, the Review Team believes that a licensee should not normally be permitted, in lieu of a CP, to spend equivalent funds on ways to improve safety. A CP should be viewed as a penalty. If a licensee believes that additional corrective action is needed to safely operate the facility, then that action should be taken. Significant legal issues also exist with the concept of offsetting CPs.<sup>3</sup>

The Team notes, however, that certain limited circumstances may arise in which alternatives may be considered in lieu of issuing a CP. For example, cleanup costs may be an appropriate consideration in determining whether to issue a CP to a facility undergoing decommissioning.<sup>4</sup>

#### *a. Financial Relevance*

Determining the proper amount of any CP can be a topic of debate; determining the proper amount for the statutory maximum, or for the agency-wide *standard* CP for a given class of licensee, can be (and historically has been) the focus of abundant discussion. Central to this discussion is the concept of financial relevance.

If CPs are to be issued at all, then their benefit should be that their function and impact are distinct from those of other available sanctions. A financial penalty is less harsh than license revocation. Similarly, while many licensees contend that upper-level executives give earnest attention to all violations, a CP clearly gets (and should get)

---

<sup>1</sup>The legislative history indicates that a CP was intended to be an intermediate sanction between an NOV and more extreme measures (in terms of impact on employees and the public) such as license revocation.

<sup>2</sup>Financial relevance can be interpreted in various ways. See the discussion under "Financial Relevance," below.

<sup>3</sup>See *NRC's Authority to Mitigate Civil Penalties*, GAO Decision B-238419 (October 9, 1990).

<sup>4</sup>The April 10, 1992 "Action Plan to Ensure Timely Cleanup of Site Decommissioning Management Plan Sites" provides that CPs should be limited to two situations. Specifically, the plan provides that "the NRC will consider civil penalties where (1) the licensee or responsible party fails to comply with an order compelling payment into an escrow account; or (2) the licensee or responsible party fails to comply with a requirement or an order compelling cleanup when there is already sufficient decommissioning funding" (57 FR 13389, April 16, 1992).

more attention than just an NOV, whatever the severity categorization.

In maintaining this distinctness from other enforcement actions, a crucial feature of the CP is its financial relevance. Issuing a \$500 CP to a power reactor licensee for a significant violation would be disproportionate to the point of being trivial; issuing a \$50,000 CP to a small licensee might be equally inappropriate, if the action, in effect, put the licensee out of business.<sup>5</sup> However, while inappropriate extremes are easy to hypothesize, giving more exact dimensions to a CP's financial relevance (i.e., tying maximum and routine CP amounts to an objective standard) remains difficult. The CP should be financially relevant, but relevant to *what*? relevant to licensee income? to inflation? to the potential economic benefit of noncompliance?

Several attempts have been made to tie CPs to an objective standard. In the 1982 version of the Enforcement Policy, the Commission stated, "It is the Commission's intent that noncompliance should be more expensive than compliance." This statement implies a quantifiable comparative standard for situations in which the licensee's failure to comply resulted in an economic benefit (e.g., a case where, by not following a license requirement to shutdown for a specific equipment failure, the reactor licensee received profits for several additional days of power operation). This approach might provide increased deterrence; however, issuing CPs based on offsetting licensee economic benefits has several problems: (1) each CP would require an individually researched (but still defensible) calculation; (2) some violations warranting CPs have little or no associated licensee economic benefit; and (3) the relative amounts of CPs may have no relation to the violation's significance (except for deliberate violations), and relatively few violations are the result of a deliberate judgment regarding economic benefit.<sup>6</sup>

In NUREG-1499, the Review Team for Reassessment of the NRC's Program for Protecting Allegers Against Retaliation recommended raising the statutory maximum CP to \$500,000 per violation, per day. This recommendation was based, in part, on \$500,000 being within the range of the typical cost of a day of replacement power for a power reactor facility. While this proposal attempts, once again, to link CP amounts to an economic standard, the amount is still somewhat arbitrary (i.e., one might, on

---

<sup>5</sup>The current Enforcement Policy uses a licensee's ability to pay as the "bottom-line" standard of a CP's financial relevance. As stated in the Policy: ". . . it is not the NRC's intention that the economic impact of a civil penalty be so severe that it puts a licensee out of business . . . or adversely affects a licensee's ability to safely conduct licensed activities."

<sup>6</sup>The Review Team has proposed in Section II.D.6.d that, as a matter of discretion, a CP may be increased where the licensee made a conscious decision to be in noncompliance in order to obtain an economic benefit. See also the discussion in Appendix D on the history of the "cost of noncompliance" concept.

the same basis, choose \$750,000 or \$1,000,000), and no clear reason exists to justify "a day of replacement power" as the *correct* standard (i.e., why not a ½-day, or 2 days, or a standard linked to some other measure?). In addition, this substantial increase would require a legislative change, a proposal the Enforcement Review Team rejected for other reasons (see discussion under II.D.3, below).

The Team also considered inflation as a measure of financial relevance. The original Enforcement Policy, in October 1980, set the base CP for an SL III violation issued to a power reactor at \$40,000; inflation in the intervening 15 years (based on the Consumer Price Index, in accordance with the Civil Penalty Inflation Act of 1990) has been about 80%, but base CP amounts have only increased by 25% (\$50,000 for SL III). Applying inflation since 1980 would result in an SL III base CP of \$72,000 (and an SL I base CP of \$144,000). While such an increase does not seem unreasonable, the Team does not believe that the overall financial relevance of CP amounts would be substantially impacted by this change.

The Team observes, as a final perspective in this area, that the idea of financial relevance may be interpreted differently by different individuals. The strongest impact of receiving a CP is not necessarily in the actual amount of money paid, but in the accompanying publicity, the cost of corrective actions, the lost operating time (in some cases), increased regulatory attention, and other similar factors. As such, the Team does not believe that a CP, to be effective, must be financially relevant in the sense of *making an independent economic impact*. Rather, it should be financially relevant in the sense that the amount of money should not be viewed as trivial--either by the licensee, the rest of the industry, or the public.

Given this understanding, the Team believes that the CP amount should be contextually relevant. In other words, one measure of a CP's significance is how it compares to other CPs issued under the same statute. In this sense, the last 15 years of NRC regulation provide a context of financial relevance, a backdrop against which members of industry and the public can measure the significance of a given CP. For instance, if a power reactor receives a \$50,000 CP, an observer mildly familiar with NRC enforcement would generally infer that the case in question, while significant, was not unusual. Penalties of \$100,000 or \$300,000 would each provoke a different reaction, even without knowing the case details, simply based on comparing the raw number to the historical context.<sup>7</sup> This perspective suggests that in determining the value of a CP, while the *absolute* dollar amount is important, the *relative* amount may be equally

---

<sup>7</sup>Penalties issued by other Federal agencies under similar statutes also help to provide a context. See the discussion under "Increasing Civil Penalty Amounts."

important.

**b. Reinforcing the Message**

When CPs are properly applied, they serve to draw additional attention to a given problem area, reinforcing the message of the accompanying NOV and transmittal letter. The effectiveness of CPs is reduced, however, unless the impact is focused and the accompanying message clear. This need for focus and clarity should be given attention both in individual actions and in the overall system for CP assessment.

**(1) Focus**

The current Enforcement Policy focuses the application of CPs in two general ways. First, CPs are issued based on a violation's significance; they *may* be proposed at SL IV, are *normally* proposed (absent mitigating circumstances) at SL III, and are considered even more rigorously at SL II and I (with particular consideration if the violation involves an overexposure, etc.). Secondly, the issuance of CPs is focused on a licensee's performance in relation to the violation--how the violation was identified, the extent of corrective action, the existence of prior opportunities to identify the violation, the licensee's relevant past performance, whether multiple examples of the violation exist, and the duration of the violation.

The Review Team believes that, in general, these two areas of focus are appropriate, but that the objectives of the overall system could be improved if the focus were even more defined. Although all SL I, II, and III violations are considered significant, certain situations suggest, more than others, the existence of an underlying performance problem that could lead to an adverse trend. For instance, a single non-willful SL III problem should not represent a broad performance problem, as long as the violation is fully corrected. When a licensee has performed for a sustained period without an escalated action, this performance generally demonstrates the ability to achieve lasting corrective action. Reducing the focus on this type of case has the potential of preserving for other regulatory activities the resources that would otherwise be expended in processing and litigating cases.

By contrast, a licensee who has had multiple escalated actions--or who is slow to identify and/or correct significant violations--is clearly an appropriate recipient of

strong regulatory attention. As shown in Figures II.D-1 and II.D-2, below, a relatively high percentage of escalated actions are issued to a relatively small percentage of reactor licensees.

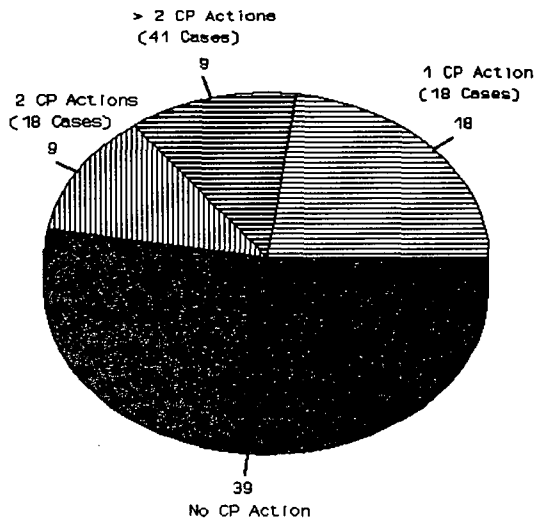

**Figure II.D-1: Sites With Civil Penalty Actions**

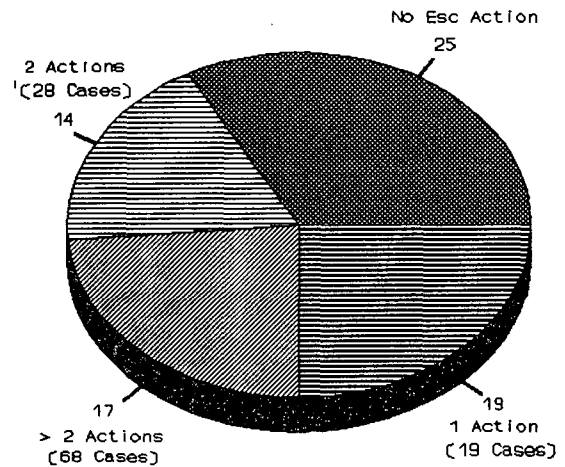

**Figure II.D-2: Sites With Escalated Actions**

Very few materials licensees have multiple escalated enforcement actions. While no SL III violation is acceptable, the Team believes that certain cases--such as (1) any SL I or II violation, (2) a willful SL III violation, or (3) the second SL III violation in a 2-year or two-inspection period--warrant additional NRC attention, especially if the licensee did not identify the violation or if an event resulted. In such cases, it is appropriate to consider not only corrective actions but also the circumstances of identification in considering whether a CP should be added to the deterrent value of the NOV.

As a result, the Review Team proposes that the CP assessment strategy should be designed to focus the NRC's attention on (1) licensees who have had more than one significant violation in a 2-year or two-inspection period (whichever is



longer)<sup>8</sup>; (2) licensees who fail to identify significant violations; and (3) licensees who fail to pursue the root causes of significant violations, or who fail to take prompt, comprehensive corrective action in a manner that will prevent recurrence. This would be consistent with the proposed revision to the purpose of the Enforcement Policy (see Recommendation II.A-1). In addition, the Team recommends that CPs no longer be considered for SL IV violations; if repetitiveness or other justification exists for a CP, then the SL IV violation may legitimately be raised to SL III.

## *(2) Clarity*

As discussed in detail in Section II.A.4.c, the complexity of the current system sometimes results in trying to send multiple messages within the issuance of a single sanction. The Review Team believes that this may at times result in each part of the message being diluted, or may send a mixed message as to what the NRC finds to be most important. In other words, if the CP is intended to strengthen the regulatory message, then that message should also be clear.

In considering changes to the CP assessment strategy, therefore, the Review Team gave particular attention to simplifying the process in a manner that would increase clarity, minimizing the number and complexity of decision points while preserving the desired emphases of the current Policy. The Team believes that the proposed approach will also result in a more predictable, understandable process. If a licensee can readily comprehend the NRC's assessment method, and if that assessment method reflects the overall objectives of the enforcement process (i.e., emphasizing compliance while reinforcing the need for identification and corrective action), then the licensee's "path to success" (i.e., the means to avoiding future violations and CPs) should be equally evident, and improved performance should result.

### *c. Differentiating Between Civil Penalties*

As discussed in Section II.A.3.b, some violations are of more concern than others, and enforcement actions should be applied on a graduated scale commensurate with the varying degree of safety significance (e.g., NCVs, NOVs, CPs, orders). In addition,

---

<sup>8</sup>For power reactor licensees, the 2-year period will generally apply; for some materials licensees, the two-inspection period would be longer than 2 years, and would therefore apply.

within the CP sanction, a wide range of penalties may be used to differentiate between violations. This differentiation may be based on:

- ◆ the type of licensee (i.e., the characterization of the nuclear material inventory, the scope of licensed activities, and the corresponding potential hazard to the public and employees);
- ◆ the safety significance of the violation, including the regulatory significance and the actual or potential safety consequence (i.e., as generally designated by the severity level);
- ◆ the degree of licensee culpability in the violation (e.g., the degree of attentiveness, whether circumstances existed beyond the licensee's control, or whether management involvement or willfulness was present);
- ◆ the circumstances of the violation (e.g., who identified it, was it promptly and comprehensively corrected, etc.); and
- ◆ the licensee's ability to pay (generally treated on a case-by-case basis).

The Review Team believes that the NRC should continue to use a graduated system of CP assessment, and that the reasons given above are appropriate bases for differentiating the size of the CP.

In addition, the Team finds merit in designating limited outcomes for the CP assessment process. Under the current system, the adjustment factors are weighted, and the final CP amount can theoretically be any number along a continuum, based on combining full or partial percentage values for the different factors. The Team notes, however, that relatively small differences in the final dollar amount (e.g., for a power reactor licensee, a CP of \$62,500 vs. a CP of \$50,000, or for a materials licensee, a CP of \$2500 vs. a CP of \$3750) make little difference in the impact of how the CP is received--even though considerable NRC discussion and effort is exerted in determining the exact weighting of each factor. Conversely, larger differences in CP amounts may, by comparison, deliver a significant message to the licensee. Therefore, while the idea of "limited outcomes" is not a goal in itself, the Team believes that a CP assessment strategy designed to result in only a few discrete options (with clear differences in CP amounts) will be more efficient, and should result in no loss of CP effectiveness.

Based on these concepts, the Team sought to design a new CP assessment strategy that would continue to differentiate CP amounts based on licensee categories, significance,

and the circumstances of the violation, but would limit the possible outcomes for routine cases, while allowing discretion for cases of unusual significance or with unique circumstances.

### 3. *Increasing Civil Penalty Amounts*

As stated earlier, the recent Review Team for Reassessment of the NRC's Program for Protecting Allegers Against Retaliation recommended, in NUREG-1499, that the Commission seek an amendment to Section 234 of the AEA, to increase the statutory maximum penalty from \$100,000 per violation, per day to \$500,000 per violation, per day. The Allegation Review Team felt that higher CPs would increase the deterrent effect by adding to the negative publicity, and that a maximum CP of \$500,000 would be more financially relevant (i.e., it would be within the range of the average cost of a day of replacement power for a power reactor). The Commission deferred making a decision on the increased CP authority related to allegation issues, asking instead that the Enforcement Review Team study CP increases in an overall enforcement context and provide the Commission with a recommendation.

In evaluating this question, the Review Team considered concepts discussed earlier, such as the overall purpose of CPs, the need for deterrence, the meaning of financial relevance, the importance of focus and clarity, and the goal of providing meaningful differentiation between CP amounts. The reasons for raising or not raising CP amounts, as presented below, were discussed extensively in meetings with NRC regional and Headquarters management at all levels. The final decision on whether to recommend an increase in CPs was made in the context of the Review Team's overall proposal for a revised method of CP assessment, as presented in Section II.D.6.

#### *a. Increased Deterrence*

As discussed in Section II.A.1.c, industry responses to the *Federal Register* request for comment argued almost uniformly that the deterrent value of NRC enforcement was largely redundant in relation to other motivations for compliance. In addition, most licensee commenters emphasized that no existing evidence links higher CPs to greater deterrence. The Team acknowledges, in the strict sense, the merits of this contention--that is, that no such *evidence* exists (in the sense of objective, empirically derived statistics). Obtaining the "evidence" to either prove or disprove the effects of raising CPs would require eliminating or systematically varying other elements (e.g., unrelated motivations for compliance, such as economic incentives or simple professionalism--or

reasons for non-compliance, such as demanding time and schedule pressures or basic human error). As such, obtaining this evidence remains implausible.

The Team considers it generally self-evident, however, that severe sanctions provide a stronger disincentive than those less severe. Factors that influence this disincentive, such as publicity and management attention, might be augmented by an overall increase in CP amounts. From that standpoint, an Enforcement Policy revision to raise overall CP amounts might be a means of heightening the pressure on less responsive licensees to improve performance.

On the other hand, as discussed earlier, the financial relevance of a given CP is not measured simply by its absolute economic impact on the licensee, but also by how it compares to other CPs issued under the same statute. Even a significant increase in CP amounts (e.g., raising the statutory maximum to \$500,000) would not ensure financial relevance in any absolute sense. As such, the deterrent effect associated with any *individual* CP under an increased statutory limit would still be largely a function of how that CP compared to others (i.e., how it compared to the new average).

**b. Increased Range**

The Team also evaluated whether an increase in overall CP amounts was needed to differentiate between violations of varying significance. Under the current strategy, an SL III base CP for a power reactor licensee is \$50,000, an SL II \$80,000, and an SL I \$100,000. In some viewpoints, these ratios do not create a meaningful differentiation between CPs of varying significance (i.e., a CP of \$80,000 does not make a substantially different impression than a CP of \$50,000 or \$100,000). Increasing the statutory maximum to \$500,000 per violation, per day would provide a much wider range of CP amounts, and would permit expanding these ratios.

The Team observes, however, that in actual application, violations of unusual significance frequently result in CPs well above average (exercising discretion as considered appropriate), in a manner that achieves meaningful differentiation even under the current strategy. Violations categorized at SL I and II are relatively rare, and the uniqueness of such cases may result in applying enforcement discretion where needed. Similarly, where an SL III violation involves unusual circumstances such as willfulness or particularly poor licensee performance, discretion may be used to provide the appropriate regulatory message.

For more routine cases, the Team believes that the goal of meaningful differentiation

between violations of varying significance may be achieved by limiting the outcomes of the CP assessment process. As discussed earlier, small differences in CP amounts may make little impact on licensees. Limiting the outcomes of the process should ensure more substantial differences between CP amounts, and should help to clarify the overall regulatory message. The Team believes that this method of differentiating between CPs can be effectively implemented with no overall increase in CP amounts.

*c. Increasing the Statutory Maximum*

The Team reviewed an extensive history of escalated enforcement actions, and observed that the NRC does not routinely exercise the maximum existing CP authority provided under the AEA (i.e., \$100,000 per violation, per day). In actual application, most of the NRC's Proposed Impositions of Civil Penalty involve more than one violation, and many violations occur over a period of 2 days or more.

For example, a proposed enforcement action for an SL III "problem" might actually involve multiple violations that, individually, would be classified as SL III or SL IV, but have been grouped into a single action to better encapsulate the overall scope. Even a single SL III violation frequently involves two or more examples, or involves an operability issue (e.g., a post-maintenance testing failure) that may have existed for an appreciable time. Maximizing the NRC's statutory CP authority of \$100,000 per violation, per day could result in penalties ranging, in some cases, in the millions of dollars. As a result, the NRC rarely finds itself limited by statutory authority in seeking to issue a CP.<sup>9</sup>

To place the NRC's CP practices in a broader context, the enforcement practices of other Federal agencies were considered. The Team observed, as an example, that the Federal Aviation Administration issues CPs of several hundred thousand dollars (based on multiple violations) to a single certificate holder covered under the Federal Aviation Act (FA Act), even though the maximum CP provisions under the FA Act authorize only \$10,000 per violation, per day. The Food and Drug Administration, the Environmental Protection Agency, and the Consumer Product Safety Commission are only a few examples of other agencies that also issue CPs in the range of several hundred thousand (or even several million) dollars, based on multiple examples (or extended duration) of violations for which the individual CP is limited by statute to a much smaller amount.

---

<sup>9</sup>The team notes that, at SL I and II, where violations are less likely to be grouped in a particular problem area, the CP may more frequently be limited (e.g., for a significant overexposure or single act of discrimination).

Based on this context, and based on the recognition that the NRC does not routinely exercise its current maximum CP authority, the Team believes that asking Congress to increase the statutory maximum would be inappropriate. The Team concludes that attention should instead be given to whether using the existing authority to raise overall base CP amounts would better meet the objectives of NRC enforcement.

**d. Overall Regulatory Message**

As a final consideration, the Team observes that, within the current socio-political climate, a move to raise overall CP amounts might be perceived as contrary to demands for less intrusive government. The Team does not believe that, of itself, this should be a determining factor; however, the Team observes that the overall enforcement objective of encouraging licensees to self-identify and correct problems without NRC involvement is consistent with the concept of reduced regulatory intrusiveness. To the extent that a reduction in regulatory impact can be accomplished while maintaining the other primary enforcement objective (i.e., emphasizing the importance of compliance), the Team believes that an appropriate balance should be achieved.

To reach a final decision on whether CP amounts should be increased or remain the same, the Team attempted to place the above considerations in the context of its overall proposal for revising the NRC's method of CP assessment. The reasoning supporting this proposed strategy is discussed in the later subsections of this report, and the strategy itself is presented in Section II.D.6.

In evaluating the overall impact and effectiveness of this proposed change, the Team spent considerable time in overlaying the proposed strategy retroactively on 1993-94 enforcement cases, and comparing the outcomes under the current and proposed systems. Differences in application and definition of the various assessment factors (as well as the use of judgment) made this effort, at best, an inexact analysis. The Team used these general estimates, however, as an aid to assessing whether, under the proposed revision, CP amounts would increase, decrease, or remain the same.

For a hypothesized "worst-case" violation, application of the Team's proposed CP assessment strategy (see Figure II.D-3) would result in issuing a CP at the base amount +100% (or \$100,000 for an SL III violation issued to a power reactor licensee). Postulating the same violation under the current Policy would, in the worst case, result in escalating for *Identification, Corrective Action, Licensee Performance, and Prior Opportunity to Identify*--for a total of the base amount +300% (or \$200,000 for a SL

III violation). On first glance, this would seem to be a substantial reduction in CP amounts under the Team's proposed strategy. In reality, however, the Team found that the average CP issued for violations in this group was approximately \$102,000.<sup>10</sup>

For CP assessments in the intermediate category (i.e., the middle outcome as shown on Figure II.D-3), the proposed strategy would result in issuing a CP at the base amount (\$50,000 at SL III). The average CP actually issued for violations in this group was about \$70,000. This suggests that the proposed strategy, if adopted, would result in a moderate decrease in CP amounts for some violations.

The Team recognizes that the overall regulatory message implicit in such a change, if viewed superficially, might be interpreted to be a relaxing of the NRC's enforcement posture. The Team believes, however, that the proposed strategy will draw a distinct difference in CP amounts, and should actually increase deterrence by clarifying the NRC's overall focus on sustained performance, prompt identification, and corrective action. The Team believes, in addition, that raising the overall base CP amounts would not substantially increase overall deterrence or provide a more appropriate regulatory message.

#### e. Conclusion

In summary, the Team concludes that, with limited exceptions as discussed in Section II.D.7.c, maintaining the existing base CP amounts should result in meaningful CPs, and should allow meaningful differentiation between violations of varying significance. In addition, the Team concludes that increasing the incentives for strong self-monitoring and corrective action programs should be better accomplished by revising the overall CP assessment process than by raising the standard CP amounts. Discretion should remain available to address situations where increased CPs are warranted to achieve the appropriate regulatory message. The Team concludes that no increase in base CPs is needed.<sup>11</sup>

---

<sup>10</sup>This difference in "hypothesized" and "real" outcomes is primarily a reflection of differences between the current and proposed assessment strategies. Under the current strategy, it would be very unusual for a licensee to receive full escalation for all four of the adjustment factors named. As the case review suggested, however, it would be less rare under the proposed strategy for the NRC to find fault with a licensee for its performance related both to *Identification* and *Corrective Action*.

<sup>11</sup>One Review Team member holds a contrary view on this issue. He believes that increasing CP amounts should be an important element in the overall proposal for revamping the NRC Enforcement Policy, for the following reasons: (1) simply adjusting for inflation suggests that base CPs should be increased; (2) increased penalties would provide a more financially relevant fine, which presumably would lead to greater deterrence, provide a better differentiation between violations of varying significance, and convey a stronger, more appropriate regulatory message to licensees and the public; and (3) the proposed policy

#### 4. *Application of Individual CP Adjustment Factors*

The Review Team deliberated extensively over this area of the Enforcement Policy. Respondents to the *Federal Register* notice almost uniformly favored some NRC consideration of the surrounding circumstances, but opinions varied widely as to how those circumstances should be applied and/or weighted in assessing any associated CP. In the Team's regional NRC discussions, the most consistent comment on CP adjustment factors was that their application should be less complex. As noted earlier, one of the Team's overall objectives in the CP area was to sharpen the focus, increase the clarity, and improve the efficiency of the process for assessing and issuing CPs, while maintaining the appropriate emphases on areas of NRC concern. This objective resulted in the Team considering a wide range of options for CP assessment.

Under the current Policy, six CP adjustment factors are used--including *Identification*, *Corrective Action*, *Licensee Performance*, *Prior Opportunity to Identify*, *Multiple Occurrences*, and *Duration*--with a possible escalating and/or mitigating CP adjustment of up to 50% or 100% for each factor. In addition, several caveats are given in the Policy: (1) allowing partial or full mitigation of the CP (or extended payments) based on a licensee's demonstrated financial hardship; (2) clarifying that a CP of at least 50% of the base amount will normally be issued for an SL I or II violation involving an overexposure, release of radioactive material, or loss of radioactive material; (3) permitting the discretion to refrain from issuing CPs under certain circumstances, including violations identified during extended shutdowns or work stoppages, violations involving old design issues, violations identified due to previous escalated enforcement, or violations involving certain discrimination issues; and (4) providing catch-all discretion to escalate or mitigate a CP as needed when application of the standard adjustment factors does not provide the appropriate regulatory message.

While, as noted below, each factor is assessed separately, the current system combines the assessments in a formula, according to the weighted percentages. The sanction that results is not always helpful in clearly focusing on the regulatory message.

The Team reviewed each factor in isolation and in relation to the other factors, and then evaluated the overall structure, including the various caveats. Section II.D.6 outlines the Review Team's proposal for simplifying and restructuring the overall CP assessment

---

should provide incentives to all licensees to identify and correct violations, reward those who do so, and penalize meaningfully those who do not.

As a result, this view concludes that a base SL III CP of \$100,000 (for power reactors) would more effectively accomplish the objectives of the Policy.



process. The following discussions give specific considerations for each factor:

**a. Identification**

The current Policy allows escalation or mitigation up to 50% of the base CP based on whether NRC or the licensee identified the issue. In addition, this factor considers licensee identification of violations resulting from self-disclosing events (i.e., an event readily obvious by human observation or instrumentation, such as a spill of liquid or an annunciator alarm). Where the licensee displays initiative in identifying the root cause of such violations, up to 25% mitigation may be applied.

In actual practice, the application of this factor to an escalated enforcement action is not always straightforward. Multiple violations are frequently involved, often with some identified by the licensee and some by the NRC. This is particularly true following an event, when the NRC and the licensee are simultaneously investigating the surrounding circumstances and seeking to identify the underlying root cause or causes. In addition, interpretations often differ on whether an event should be considered "self-disclosing."

In assessing how this factor should be applied, the Team sought to answer a wide range of questions. For example: Is it more important that the licensee identify the event, the violation, or the underlying root cause? When an NRC inspector, following an event, identifies a violation that the licensee would likely have identified independently, should the licensee be given credit? If a "self-disclosing event" occurs as the result of licensee initiative (e.g., performing a surveillance or designing an alarm panel to provide conservative indication of developing trends), why should the licensee not be given full identification credit? If a licensee audit identifies a problem that later turns out to be a violation but was not initially recognized as such, should the licensee be denied identification credit (or conversely, given credit for identification but penalized for lack of prompt corrective action)?

The Team sought to design a CP assessment strategy that would address the following objectives related to *Identification*:

- (1) Increase the overall incentive for licensee self-monitoring. Normally, eliminate CPs for cases in which the licensee identifies the violation and takes prompt, comprehensive corrective action (this objective is discussed in more detail under *Corrective Action*, below).
- (2) Increase the credit given to the licensee for promptly identifying any underlying

violations and root causes for self-disclosing events, where those events resulted from licensee self-monitoring initiatives, such as performing surveillances, audits, or radiological surveys.

- (3) Clarify the NRC method of giving or not giving licensee *Identification* credit when the violation has been revealed through an event.
- (4) Clarify the NRC practice of giving credit when an NRC-identified violation would likely have been independently identified by the licensee, based on timing, licensee resources, and other factors.
- (5) Clarify the meaning of *Identification* to mean identification of the problem requiring corrective action.

**b. Corrective Action**

The current Policy allows escalation or mitigation up to 50% of the base CP based on whether the licensee's immediate and long-term corrective actions were prompt and comprehensive. Immediate actions are assessed for effectiveness in restoring safety and compliance. Long-term actions are assessed for effectiveness in addressing the root cause and adequacy in preventing recurrence of the same or similar violations. The assessment also considers the timing of the actions, and whether excessive NRC prompting was needed. This consideration is further complicated by provisions that, in some instances, the failure to achieve lasting corrective action is a significant violation in itself.

In earlier versions of the Enforcement Policy, the standard for this factor was termed "*unusually* prompt and comprehensive" corrective action. In 1988, the NRC changed this standard to simply "prompt and comprehensive." This change reflects the NRC's recognition that, in some cases, there is nothing unusual about the corrective action even though it is clear that the action taken was prompt and extensive. Furthermore, even when the licensee has addressed the underlying root cause in a manner that should prevent recurrence of the violation, the NRC may note additional peripheral or minor corrective action still to be taken.

The Review Team believes that judgment on the adequacy of corrective actions should hinge on whether the NRC needs to take action to focus the licensee's evaluative and corrective process in order to obtain comprehensive corrective action. This is normally judged at the time of the predecisional enforcement conference (e.g., by outlining

important additional areas where corrective action is needed). Earlier informal discussions between the licensee and NRC inspectors or management may result in improved corrective action, but should not normally be a basis to deny credit for *Corrective Action*.

The Team also notes that, under the current Policy, the factors of *Licensee Performance*, *Prior Opportunity to Identify*, and *Duration* are weighted more heavily (at 100% each) than *Identification* or *Corrective Action* (at 50% each). As a result, a self-identified and corrected violation may still result in a CP.<sup>12</sup> The Team concludes that changes are appropriate in order to strengthen the focus on licensee identification and correction of conditions adverse to quality. The Team sought to design a CP assessment strategy that would achieve the following objectives related to *Corrective Action*:

- (1) Normally, eliminate CPs for cases in which the licensee identifies the violation and takes prompt, comprehensive corrective action.
- (2) Clarify the NRC's method of assessing comprehensiveness, promptness, and the relative weight of immediate and long-term corrective action.
- (3) Clarify that timeliness, for this factor, is assessed from the point at which the licensee realizes that the problem requires corrective action.

*c. Licensee Performance*

The current Policy allows escalation or mitigation up to 100% of the base CP based on the licensee's performance. Under this factor, normally the past 2 years or past 2 inspections, whichever is longer, may be considered both in terms of overall performance and performance specifically related to the area of the violation. Particular consideration is given to overall declining or improving performance trends, both general and specific. The significance of specific past violations is also assessed, particularly if the corrective actions for a previous violation should have prevented the present one.

As noted earlier, the Review Team believes that a relatively isolated SL III violation in a given area over a 2-year period may not indicate a significant licensee performance

---

<sup>12</sup>Note that the 50% weighting currently assigned to *Identification* and *Corrective Action* is based on not giving full mitigation credit unless the licensee has *both* identified and corrected the problem.

problem if fully corrected. The Team also concludes that the scope of consideration for *Licensee Performance* should be narrowed, and that current performance should be given more weight than past performance. In part, these conclusions are based on the existence of other NRC tools, such as Systematic Assessment of Licensee Performance (SALP), that can be used to encourage good performance. The Team also concludes that reducing consideration of *Licensee Performance* as a CP adjustment factor in certain cases (where the licensee identifies and corrects the violation) is consistent with the overall enforcement objectives.<sup>13</sup>

The Team sought to design a CP assessment strategy that would achieve the following objectives related to *Licensee Performance*.

- (1) Normally, eliminate CPs for cases involving a relatively isolated SL III violation over a 2-year or two-inspection period (whichever is longer), as long as the violation has been fully corrected.
- (2) Give less emphasis to poor past performance when the licensee's current performance is characterized by self-identifying and promptly, comprehensively correcting the violation.
- (3) For cases in which *Licensee Performance* is considered, normally narrow the scope to apply only when a significant violation is directly repetitive, or when the corrective action for a previous violation should have prevented the present instance. These considerations should normally apply to violations occurring within the past 2 years or 2 inspections (whichever is longer).

**d. *Prior Opportunity to Identify***

The current Policy allows escalation up to 100% of the base CP when the licensee has had a prior opportunity to identify the violation. These prior opportunities may include internal quality assurance (QA) audit findings, NRC generic industry notices, or other reasonable indications such as employee or contractor observations that should have been addressed. Escalation for this factor is not normally considered when the licensee took or planned to take reasonable action for the notification.

The Team's assessment of how this factor ought to be applied involves logic similar to that for *Licensee Performance*. Again, the Team concludes that the weight given

---

<sup>13</sup>Note that discretion should still be preserved to address issues where poor performance is recurring.

this factor should be reduced for cases in which the licensee self-identifies and promptly, comprehensively corrects the problem. The Team believes, however, that this factor should be retained for NRC-identified cases, or for cases in which the violation is revealed through an event. As under the current Policy, the Team concludes that prior opportunities should normally be considered over the period of the past 2 years or past 2 inspections, whichever is longer.

The Team sought to design a CP assessment strategy that would achieve the following objectives related to *Prior Opportunity to Identify*:

- (1) Normally, eliminate consideration of *Prior Opportunity to Identify* when the licensee's current efforts result in identifying and promptly, comprehensively correcting the violation.
- (2) For cases in which the NRC identifies the violation or the violation is revealed through an event, consider any prior licensee opportunities to identify or prevent the violation as a basis on which to determine whether the licensee should be given credit for its actions related to *Identification*. These prior opportunities should normally have occurred within the past 2 years or 2 inspections.
- (3) Clarify the NRC's method of assessing *Prior Opportunity to Identify*.

*e. Multiple Occurrences*

The current Policy allows escalation up to 100% of the base CP for violations involving multiple examples. In general, this factor is only applied when the examples have the same root cause.

The Team finds this factor to be unnecessary, based on the overall goal of reducing the complexity of the CP assessment process. Where the NRC desires to give additional emphasis because of multiple occurrences of a violation, that emphasis may be achieved by separately assessing a CP for each violation. The proposed CP assessment process discussed in Section II.D.6 eliminates this adjustment factor.

*f. Duration*

The current Policy allows escalation up to 100% of the base CP for continuing violations of more than 1 day in duration or where the impact continues for more than

1 day. As implemented, this factor has not been routinely used. Current guidance proposes use of this factor only for violations of particular safety or regulatory significance, where the NRC wishes to emphasize the significance of the violation remaining uncorrected for more than 1 day.

The Team finds this factor also to be unnecessary, given its relatively rare use and based on the overall objective of reducing the complexity of the CP assessment process. The proposed CP assessment process discussed in Section II.D.6 eliminates this adjustment factor. Any use of *Duration* to increase the CP amount will be considered within the exercise of discretion.

### 5. *Interrelatedness of CP Adjustment Factors*

As might be inferred from the above discussions, the individual CP adjustment factors are often interrelated. The historical evolution of strategies for applying adjustment factors, as outlined in Appendix D, reflects this interrelatedness.

At times, the relationship between factors is one of overlap. For example, a repetitive violation generally results in a negative adjustment for *Licensee Performance* in the area of concern--yet the licensee's efforts to correct the first violation might also be considered a *Prior Opportunity to Identify* the current problem. Similarly, when a violation has multiple examples or has existed for an extended duration, the *Multiple Occurrences* or *Duration* might also be seen as *Prior Opportunities to Identify*.

For other cases, the logic of applying one factor may interfere with another. As an illustration: why should a licensee be given credit for self-identifying a violation if there has clearly been a failure to take advantage of prior opportunities to identify it? Similarly, if a licensee identifies a violation, but fails to take comprehensive corrective action, should any credit be given for *Identification*?

The interrelation of factors also emerges for enforcement cases in which multiple licensee-identified (or self-disclosing) violations are combined into an overall SL III problem. These cases often arise because the NRC has determined that a larger, "programmatic" problem exists. The assessment of such a case may show that the licensee was correcting the individual symptoms of each violation as it arose, but failing to address the overall root cause linking the violations together. As a result, one application of the current adjustment factors might be to say that the licensee identified the individual violations but failed to take comprehensive corrective action for the aggregate problem. Conversely, another equally valid application might be to say that the NRC identified the problem requiring corrective

action (i.e., identified the programmatic issue), and that the licensee's corrective action was prompt and comprehensive once the NRC had given the licensee notice.

*a. Use of a Formula*

Since 1980, the various CP adjustment strategies included in the Enforcement Policy have tried to solve this interrelation of factors by separating the factors and giving a specific weight to each. The result is a formula in which the dollar amount of the base CP is adjusted by a fixed percentage (or fraction of the fixed percentage) based on the evidence related to each adjustment factor. Although multiple alternative strategies were reviewed, the Team determined that any formula of this type would encounter certain disadvantages:

- (1) Since different types of cases make different factors more important, the relative weighting of factors according to a fixed formula will fit some cases better than others. Thus, it is difficult to construct a universal system by assigning a fixed weight to all conceivable adjustment factors.
- (2) By focusing on the percentage value assigned to each factor in a given case, this adjustment process creates the mistaken impression that the *regulatory message* received by the licensee (as well as the rest of the industry and the public) is closely tied to the exact *amount* (or fractional amount) of the CP. As a result, a great deal of time and energy is diverted into judgments over the fractional adjustments to be made for each factor, when in fact most concerned parties agree that small differences in the amount of the final CP are relatively inconsequential in terms of the message delivered.

In view of these considerations, the Team sought to design a CP assessment strategy that would be less focused on the numeric weighting to be given each factor (in a manner universally applicable to all enforcement cases), and would focus instead on reinforcing the overall objectives of the enforcement program.

*b. "Double Counting"*

Another difficulty that arises from adjustment factors being interrelated is the accusation of "double counting" (i.e., using the same set of circumstances as the basis for escalating on two or more different adjustment factors). Under the current CP adjustment scheme, double counting of this sort is generally to be avoided. For

example, if multiple examples of a violation exist, it might be appropriate to escalate for *Multiple Occurrences*, or to view the earliest examples as *Prior Opportunities to Identify*; however, it would probably not be appropriate to escalate for *both* factors.

More frequently, the problem of double counting occurs when the same facts are used to establish the violation, categorize the severity level, and adjust the CP amount. This issue is always fact-dependent. For example, consider a case where, for several shifts, a control room annunciator is overlooked by the licensed operators. The failure to respond to the annunciator establishes the violation; extension of the failure over several shifts may be used to justify raising the violation to an SL III; depending on how long the problem lasts, the same facts (i.e., overlooking the annunciator) might be used to increase the CP amount for *Prior Opportunity to Identify* (or for *Multiple Examples or Duration*).

As another example, suppose that, within a 2-week period, various operational errors cause four separate events, each resulting in a violation that, in itself, would be classified at SL IV. The NRC might determine, in this case, that an overall programmatic problem exists with the licensee's command and control of operational procedures, and combine the violations to constitute an SL III problem. If sufficient examples of the violation exist, the basis might also exist to escalate for *Multiple Occurrences*; to do so could be considered double counting, since the multiple instances were also the justification for raising the overall problem to SL III. The Review Team believes that, in each situation, the merits of the case must be individually weighed.<sup>14</sup>

The Team sought to design a CP assessment strategy that would clarify application of interrelated factors, in a manner that would minimize the use of double counting in the application of assessment factors. The Review Team believes it is appropriate to continue to make a case-by-case determination as to whether the same facts are appropriate to be used in determining the violation, the severity level, and the sanction.

**c. *Factors Relating to Identifying the Violation***

The interrelatedness of adjustment factors is particularly evident in the area of Identification. Each version of the Enforcement Policy since 1980 has proposed generally giving some mitigation when the licensee clearly identified the violation. Certain versions have also included, as part of applying this factor: (1) weighing the

---

<sup>14</sup>Depending on the severity of the circumstances, such a case might also be assessed for separate violations or daily civil penalties.



promptness of identification, (2) assessing the ease of discovery, (3) considering whether the identified condition was also reported, if required, (4) evaluating the degree of licensee initiative demonstrated in identifying the problem, (5) escalating when NRC identifies the violation, (6) mitigating partially when the violation was identified as the result of a self-disclosing event, and (7) giving less credit when the licensee failed to take advantage of prior opportunities to identify the violation.

Under the current Policy, the *Identification* factor only considers *who* identified the violation (i.e., the NRC or the licensee) and for self-disclosing events, the degree of licensee initiative demonstrated in finding the root causes. Elements such as promptness, ease of discovery, and prior opportunities are considered separately under the *Prior Opportunity to Identify* factor. Where reports are required, the failure to report an identified violation is addressed as a separate violation.

The Team observes that separating these interrelated elements does little to increase predictability or to ensure the proper weighting of the circumstances for a given case--primarily because each consideration related to *Identification* becomes more or less important depending on the specific case. For instance, the existence of prior opportunities might be a major factor in judging whether or not to give credit for a self-disclosing event, but might be viewed less negatively in a case where the licensee identifies the problem before an event results.<sup>15</sup> As a result, the Team believes that more focus should be placed on clarifying how these considerations might vary from case to case. Rather than insisting on a fixed set of percentages that might result in a mixed message, the NRC evaluators should seek to answer a basic question: should the licensee be given credit for actions related to *Identification*?

The Team sought to design a CP assessment strategy that would be less focused on *separating the elements for consideration* related to *Identification*, and more focused on *distinguishing among different types of cases* (i.e., giving guidance as to which elements should be considered most strongly for a given type of case).

## 6. *Proposed CP Assessment Strategy*

The Team devoted considerable time and deliberation toward constructing a workable, practical CP assessment strategy that would, if possible, maintain a clear focus on the overall enforcement objectives while reducing the overall level of enforcement-related effort

---

<sup>15</sup>Presumably, in order to achieve self-identification before the event occurred, the licensee would have to have been responsive to one of the "prior" opportunities.

(time, paperwork, and resources). The resultant proposed strategy is summarized graphically in Figure II.D-3, below:

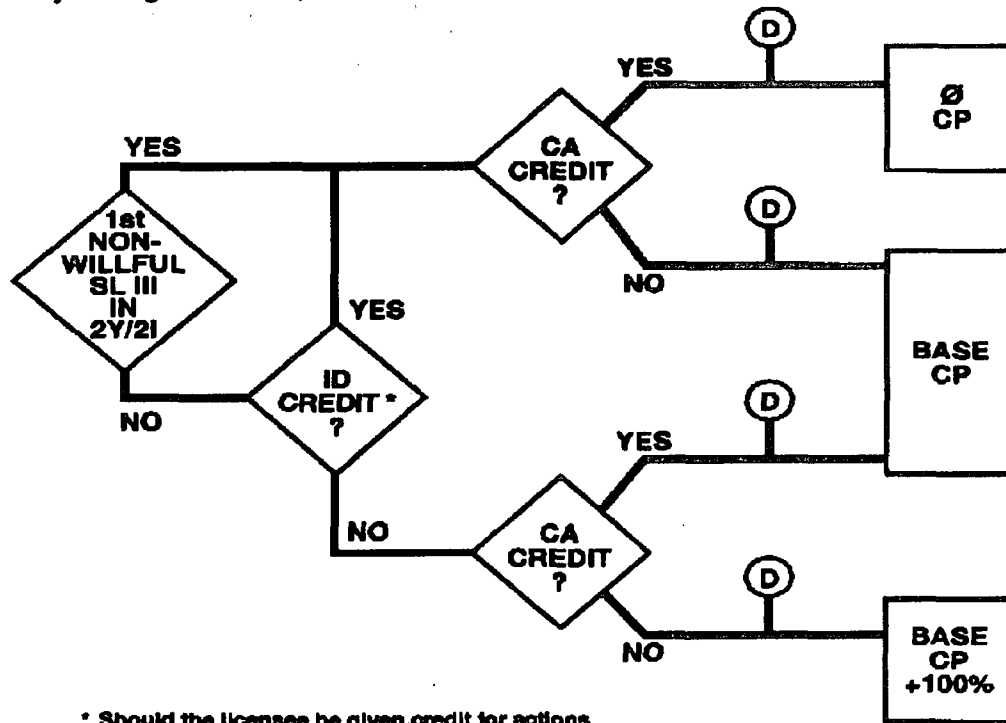

\* Should the licensee be given credit for actions related to identification?

**(D)** Discretion, e.g., SL I and II violations should normally result in a civil penalty regardless of ID and CA.

The Team believes that this assessment strategy, as summarized in the flowchart and as discussed in the narrative that follows, should:

- ◆ Continue to emphasize compliance in a manner that deters future violations;
- ◆ Encourage prompt identification and prompt, comprehensive correction of violations;
- ◆ Apply the recognition of good past performance to give credit to a licensee committing a non-willful SL III violation who has had no previous significant violations during the past 2 years or 2 inspections (whichever is longer);
- ◆ Place greater attention on situations of greater concern (i.e., where a licensee has had

more than one significant violation in a 2-year or two-inspection period, where corrective action is less than prompt and comprehensive, or where egregious circumstances such as direct repetitiveness or willfulness are involved);

- ◆ Streamline the NRC decisional process in a manner that will preserve judgment and discretion, but will provide a clear normative standard and produce relatively predictable results for routine cases; and
- ◆ Provide clear guidance on applying fewer factors in various types of cases, in order to increase consistency and predictability.

The flowchart in Figure II.D-3 provides a graphic representation of the proposed CP assessment process. Once a violation has been determined to be SL III or above, the entire process consists, at most, of four basic decisional points: (1) whether the licensee has had a previous escalated enforcement action during the past 2 years or past 2 inspections, whichever is longer; (2) whether the licensee should be given credit for actions related to *Identification*; (3) whether the licensee's corrective actions may reasonably be considered prompt and comprehensive; and (4) whether, in view of all the circumstances, the case in question requires the exercise of discretion.

While each of these decisional points may have several associated considerations, the outcome for a routine case (i.e., no CP, a base CP, or a base CP +100%) should be predictable according to this standard strategy--that is, differing groups of NRC evaluators, given the same set of circumstances, should come to the same conclusion.

#### *a. Initial Escalated Action*

The decision regarding previous escalated actions should focus on the past 2 years or previous 2 inspections, whichever is longer. Using 2 years as the basis for assessment is expected to cover most situations, but considering a slightly longer or shorter period might be warranted based on the circumstances of a particular case. The starting point of this period should be considered the date when the licensee was put on notice of the need to take corrective action. For a licensee-identified violation or an event, this would be when the licensee is aware that a problem or violation exists requiring corrective action. For an NRC-identified violation, the starting point would be when the NRC puts the licensee on notice, which could be during the inspection, at the inspection exit meeting, or as part of post-inspection communication. The enforcement correspondence should reference the date when the licensee was put on notice.

As shown in the partial flowchart above, when the NRC determines that a non-willful

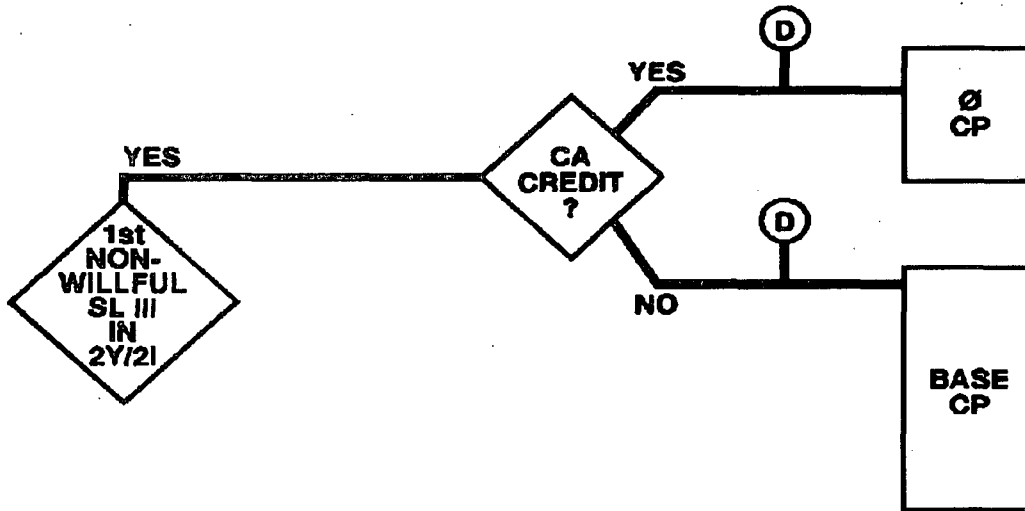

SL III violation has occurred, and the licensee has not had a previous escalated action during the past 2 years or 2 inspections, the only additional consideration should be whether the licensee's corrective action for the present violation may reasonably be considered prompt and comprehensive. If the corrective action is judged to be prompt and comprehensive, the NOV should be issued with no associated CP. If the corrective action is judged to be less than prompt and comprehensive (see the discussion in Section II.D.6.c, below), the NOV should be issued with a base CP. This decisional point recognizes that a relatively isolated SL III problem, if promptly and comprehensively corrected, may not represent a significant performance problem.

Regardless of the CP assessment outcome (i.e., whether or not a CP is issued), an escalated action should result in the licensee being reinspected within 6 to 12 months after having been put on notice of the problem.

**b. Credit for Actions Related to Identification**

As illustrated by the partial flowchart below, when the NRC determines that, during the past 2 years or 2 inspections, the licensee has been issued at least one other

escalated action, additional factors should be considered in the CP assessment.<sup>16</sup> The first of these is whether the licensee should be given credit for actions related to *Identification*.

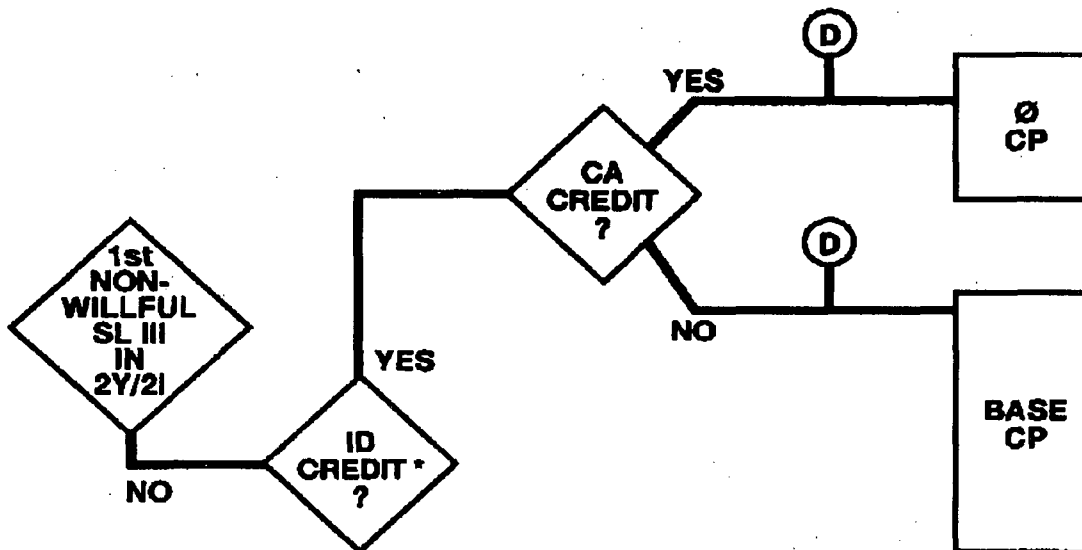

As discussed earlier, a wide range of factors may be considered in deciding whether to grant licensee credit for *Identification*. These factors include:

- ◆ whether the problem requiring corrective action was NRC-identified, licensee-identified, or revealed through an event;
- ◆ whether prior opportunities existed to identify the problem requiring corrective action, and if so, the age and number of those opportunities;
- ◆ whether the problem was revealed as the result of a licensee self-monitoring effort, such as conducting an audit, a test, a surveillance, a design review, or troubleshooting;

<sup>16</sup>For an SL I or II violation or a willful SL III violation, the CP assessment process will normally begin here. This is because, for these violations, credit is not normally given for the absence of a previous action in the past 2 years or 2 inspections.

- ◆ for a problem revealed through an event, the ease of discovery, and the degree of licensee initiative in identifying the root cause of the problem and any associated violations;
- ◆ for NRC-identified issues, whether the licensee would likely have identified the issue in the same time-period if the NRC had not been involved;
- ◆ for NRC-identified issues, whether the licensee should have identified the issue (and taken action) earlier; and
- ◆ for cases in which the NRC identifies the overall problem requiring corrective action (e.g., a programmatic issue), the degree of licensee initiative or lack of initiative in identifying the problem or problems requiring corrective action.

Based on this range of factors, the decision on whether to grant the licensee credit for actions related to *Identification* will clearly involve some judgment. Note that, in each case, the decision should be focused on identification of *the problem requiring corrective action*.<sup>17</sup> In other words, while giving credit for *Identification* and *Corrective Action* should be separate decisions, the concept of *Identification* presumes that the identifier recognizes the existence of a problem, and understands that corrective action is needed.<sup>18</sup>

Although some cases may consider all of the above factors, the importance of each factor will vary based on the type of case, as discussed in the following guidance (see Appendix G for additional examples of applying this factor):

- (1) When a problem requiring corrective action is licensee-identified (i.e., identified before the problem has resulted in an event),<sup>19</sup> the NRC should normally give the

---

<sup>17</sup>The term "problem" is used here, rather than "violation," because the NRC does not generally focus on whether the licensee identified the particular provision of the NRC regulation or other requirement violated, but instead on whether the licensee identified the *issue of concern*. The NRC also uses the term "problem" to refer to an overall escalated enforcement action (e.g., "a Severity Level III problem"), in cases where more than one violation is associated with the overall action.

<sup>18</sup>For example, if an operator notices an alarm and simply silences it without considering what is being signalled, *Identification* may not have occurred because the problem requiring corrective action has not been recognized. As such, credit for *Identification* may not be given if no indication exists that the licensee understood the need for action at some level.

<sup>19</sup>An "event," as used here, means (1) an event characterized by an active adverse impact on equipment or personnel, readily obvious by human observation or instrumentation, or (2) a radiological impact on personnel or the environment in excess of regulatory limits, such as an overexposure, a release of radioactive material above NRC limits, or a loss of radioactive material. For example, an equipment failure discovered through a spill of liquid, a loud noise, the failure to have a system respond properly, or an annunciator alarm would be considered an event; a system discovered to be inoperable through a document

licensee credit for actions related to *Identification*, regardless of whether prior opportunities existed to identify the problem.

- (2) When a problem requiring corrective action is identified through an event, the decision on whether to give the licensee credit for actions related to *Identification* should consider the ease of discovery, whether the event occurred as the result of a licensee self-monitoring effort (i.e., whether the licensee was "looking for the problem"), the degree of licensee initiative in identifying the problem or problems requiring corrective action, and whether prior opportunities existed to identify the problem.

Any of these considerations may be overriding if particularly noteworthy or particularly egregious. For example, if the event occurred as the result of conducting a surveillance or similar self-monitoring effort (i.e., the licensee was looking for the problem), the licensee should normally be given credit for identification. As a second instance, even if the problem was easily discovered (e.g., revealed by a large spill of liquid), the NRC may choose to give credit because noteworthy licensee effort was exerted in ferreting out the root cause and associated violations, or simply because no prior opportunities (e.g., procedural cautions, post-maintenance testing, quality control failures, readily observable parameter trends, or repeated or locked-in annunciator warnings) existed to identify the problem.

- (3) When a problem requiring corrective action is NRC-identified, the decision on whether to give the licensee credit for actions related to *Identification* should be based on an additional question: should the licensee have reasonably identified the problem (and taken action) earlier? If the NRC decides that the licensee *should* have identified the problem earlier, the NRC should articulate the reason for that decision.

In most cases, this reasoning may be based simply on the ease of the NRC inspector's discovery (e.g., conducting a walkdown, observing in the control room, performing a confirmatory NRC radiation survey, hearing a cavitating pump, or finding a valve obviously out of position). In some cases, the licensee's

---

review would not. Similarly, if a licensee discovered, through quarterly dosimetry readings, that employees had been inadequately monitored for radiation, the issue would normally be considered licensee-identified; however, if the same dosimetry readings disclosed an overexposure, the issue would be considered an event (see Appendix G for additional examples).

missed opportunities to identify the problem might include a similar previous violation, NRC or industry notices, internal audits, or readily observable trends.

If the NRC identifies the violation but concludes that, under the circumstances, the licensee's actions related to *Identification* were not unreasonable, the matter would be treated as licensee-identified for purposes of assessing the CP. In such cases, the question of *Identification* credit shifts to whether the licensee should be penalized for NRC's identification of the problem.

- (4) The evaluation of missed opportunities should hinge on whether the information available to the licensee should reasonably have caused action that would have prevented the violation. This assessment of "reasonable licensee action" requires weighing the facts of the case. For example, a licensee might respond to an NRC information notice by auditing a sample of related activities to determine whether a problem exists. Assuming that the sample size was reasonably established and the audit was professionally performed, the fact that the licensee missed a violation does not mean that the response to the NRC notice was unreasonable (i.e., the notice need not be considered a missed opportunity).

In some situations the missed opportunity is a violation in itself. The failure to perform post-maintenance testing may be a missed opportunity to identify faulty maintenance that results in inoperable equipment. Similarly, the failure to perform a radiological survey with a resulting overexposure would be a missed opportunity to prevent the overexposure. In these cases, unless the missed opportunity is an SL III violation in itself, the missed opportunity violation may be grouped with the other violations into a single SL III "problem."

However, if the missed opportunity is the *only* violation, then it should not normally be counted twice (i.e., both as the violation and as a missed opportunity--"double counting"). An example of this is a failure to survey where the radiation exposure received was not in itself a violation. Another example might be a failure to respond to annunciators for several shifts where the annunciators were signaling a degraded condition that did not in itself constitute a violation or result from a violation. The failure to survey or respond may, depending on the circumstances, rise to an SL III violation; however, neither would normally be considered a missed opportunity in the situation described, unless the number of opportunities missed was particularly significant.

The timing of the missed opportunity should also be considered. Escalating a



current CP action for an opportunity missed many years ago may have little purpose in addressing current performance. While a rigid time-frame is unnecessary, a 2-year period should generally be considered for consistency in implementation, as the period reflecting relatively current performance.

This manner of considering timing should not be taken to imply that a licensee is only responsible for information (such as NRC, industry, and vendor notices) issued within the previous 2 years. For example, consider a case where a valve failure that results in a violation was caused by a faulty limit switch, and the vulnerability of that type of limit switch was the subject of an industry notice 7 years earlier. The existence of a 7-year-old industry notice may not in itself constitute a missed opportunity (absent a reason to more recently review the design); however, if a system design review performed 1 year ago failed to consider all relevant information (including the 7-year-old notice), that design review might be considered a missed opportunity.

- (5) For "mixed" identification situations (i.e., where multiple violations exist, some NRC-identified, some licensee-identified), the NRC's evaluation should determine whether the licensee could reasonably have been expected to identify the violation in the NRC's absence. This determination should consider, among other things, the timing of the NRC's discovery, the scope of the licensee's efforts, the level of licensee resources given to the investigation, and whether the NRC's path of analysis had been dismissed or was being pursued in parallel by the licensee.
- (6) For cases in which the NRC determines that a programmatic breakdown has occurred, this determination is generally based on a series of violations or events for which the root cause is similar. In some cases, the licensee may have addressed the isolated symptoms of each violation (and may have identified the violations), but failed to recognize the common root cause and take broad-scope action. Where this is true, the decision on whether to give licensee credit for actions related to *Identification* should focus on identification of *the problem requiring corrective action* (i.e., the programmatic breakdown). As such, depending on the chronology of the various violations, the earliest of the individual violations might be considered missed opportunities for the licensee to have identified the larger problem.

When the NRC determines that the licensee should receive credit for actions related to *Identification*, the CP assessment should normally result in either no CP or a base CP, based on whether *Corrective Action* is judged to be reasonably prompt and comprehensive. As shown in the partial flowchart below, when the licensee is *not*

given credit for actions related to *Identification*, the same judgment on *Corrective Action* should normally result in either a base CP or a base CP +100%, because the licensee's performance is clearly not acceptable.

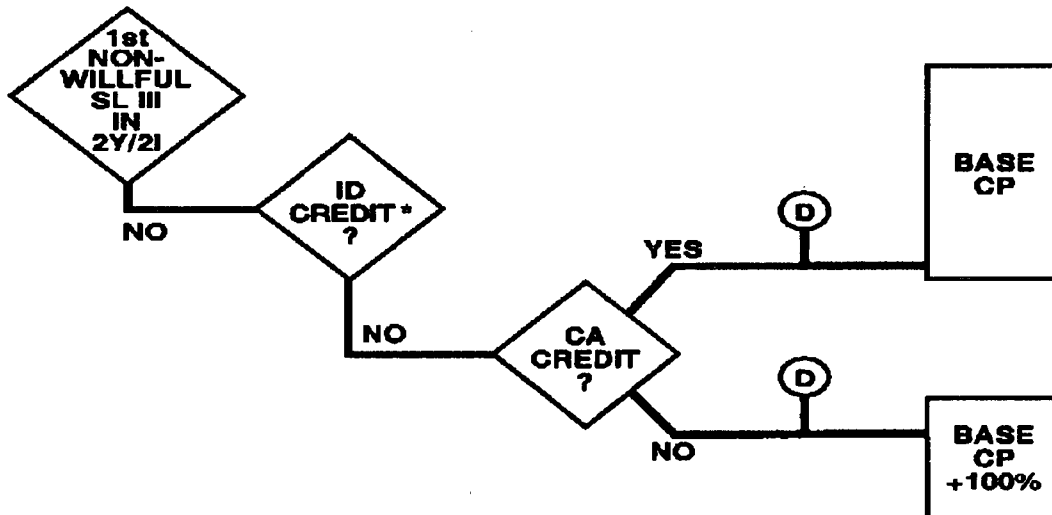

*c. Credit for Prompt and Comprehensive Corrective Action*

The purpose of this factor is to encourage licensees (1) to take the immediate actions necessary upon discovery of a violation that will restore safety and compliance with the license, regulation, or other requirement; and (2) to develop and implement (in a timely manner) the lasting actions that will not only prevent recurrence of the violation at issue, but will be appropriately comprehensive, given the significance and complexity of the violation, to prevent occurrence of violations with similar root causes.

Regardless of other circumstances (e.g., past enforcement history, identification), the licensee's corrective actions should always be evaluated as part of the CP assessment process. As a reflection of the importance given to this factor, an NRC judgment that the licensee's corrective action has not been prompt and comprehensive will always result in issuing at least a base CP. The NRC should articulate the reason for any such judgment.

In assessing this factor, consideration will be given to the timeliness of the corrective action (including the promptness in developing the schedule for long-term corrective action), the adequacy of the licensee's root cause analysis for the violation, and, given

the significance and complexity of the issue, the comprehensiveness of the corrective action (i.e., whether the action is focused narrowly to the specific violation or broadly to the general area of concern). Even in cases where the NRC, at the time of the predecisional enforcement conference, identifies additional peripheral or minor corrective action still to be taken, the licensee may be given credit in this area, as long as the licensee's actions addressed the underlying root cause and are considered sufficient to prevent recurrence of the violation and similar violations.

Normally, the judgment of the adequacy of corrective actions will hinge on whether the NRC had to take action to focus the licensee's evaluative and corrective process in order to obtain comprehensive corrective action. This will normally be judged at the time of the predecisional enforcement conference (e.g., by outlining substantive additional areas where corrective action is needed). Earlier informal discussions between the licensee and NRC inspectors or management may result in improved corrective action, but should not normally be a basis to deny credit for *Corrective Action*. Notwithstanding eventual comprehensive corrective action, if immediate corrective action was not taken to restore safety and compliance once the violation was identified, corrective action would not be considered prompt and comprehensive.

For cases in which the licensee does not get credit for actions related to *Identification* because the NRC identified the problem, the assessment of the licensee's corrective action should begin from the time when the NRC put the licensee on notice of the problem. For example, consider a case in which the NRC determines that a programmatic breakdown has occurred, based on a series of violations or events for which the root cause is similar, none of which would individually rise to an SL III. In such a case, the adequacy of the licensee's corrective actions should be judged from the time the NRC puts the licensee on notice of the broad-scope problem (i.e., the programmatic breakdown).

Corrective action for violations involving discrimination should normally only be considered comprehensive if the licensee takes prompt, comprehensive corrective action that (1) addresses the broader environment for raising safety concerns in the workplace, and (2) provides a remedy for the particular discrimination at issue.

**d. *Exercise of Discretion***

The CP assessment strategy described above is intended to be a normative standard for most SL III issues. Departures from this standard should require the approval of high-level Headquarters management, and should be in keeping with the following guidance:

- (1) Problems categorized at SL I or II should normally result in issuing at least a base CP based on the significance of the problem.
- (2) Overexposures, releases of radiological material in excess of NRC requirements, or cases involving the loss of a source should be considered for a CP.
- (3) Situations involving particularly poor licensee performance, or involving willfulness, should be considered for a CP.
- (4) When the licensee's previous enforcement history has been particularly poor, or when the current violation is directly repetitive of an earlier violation, the current CP action may be additionally escalated.
- (5) When the excessive duration of a problem has resulted in a substantial increase in risk, the CP action may be additionally escalated to reflect this increase.
- (6) Where the licensee's sustained performance has been particularly good, the CP action may be mitigated.
- (7) Where the licensee made a conscious decision to be in noncompliance in order to obtain an economic benefit, the CP may be increased.

In addition, certain criteria for mitigating in exceptional circumstances should be retained from the existing Enforcement Policy. In Section VII.B of the Policy, "Mitigation of Enforcement Sanctions," these criteria are:

- ◆ Violations Identified During Extended Shutdowns or Work Stoppages;
- ◆ Violations Involving Old Design Issues;<sup>20</sup>
- ◆ Violations Identified Due to Previous Escalated Enforcement Action; and
- ◆ Violations Involving Certain Discrimination Issues

Finally, a provision for general discretion should remain in the Policy. The Enforcement Policy is a policy, not a rule. As such, the NRC always retains the discretion to make adjustments for special cases. This may include increasing or decreasing the CP amount, eliminating the CP, or even refraining from issuing the NOV. The guiding principle in exercising this discretion is simply that such adjustments should be made, as needed, to ensure that the sanction reflects the

---

<sup>20</sup>This discretion should be available regardless of the formality of the licensee's initiative.

significance of the circumstances and conveys the appropriate regulatory message.<sup>21</sup>

*e. Assigning Final CP Amounts*

The statutory maximum CP amount, as established in the 1980 revision to the AEA, is \$100,000 per violation, per day. To calculate the statutory maximum for a given SL I, II, or III problem, each associated violation should be assigned the \$100,000 value, multiplied by the number of days the violation existed, and then added to the CP amounts for the other violations. In other words, the statutory maximum for a given SL I, II, or III problem is the cumulative result of the number of associated violations and the number of days that each violation existed.

The CP assessment scheme described above, including the exercise of discretion, should be used to arrive at a CP amount that appropriately conveys the desired regulatory message. This amount should then be compared with the amount allowed by statute, to ensure that the CP amount actually issued is within the statutory maximum.<sup>22</sup> If the desired CP amount is within the statutory maximum, then the CP should be issued at the desired amount. If the desired CP amount exceeds the statutory maximum, then the amount actually issued should be at the statutory maximum. For cases in which the CP issued is less than the desired amount, based on the statutory maximum, the NRC's correspondence to the licensee should clarify the basis for the final CP amount.<sup>23</sup>

*f. Summary of Proposed CP Assessment Strategy*

The Review Team believes that this CP assessment strategy, as described above, will strengthen the focus, clarity, and effectiveness of the overall CP process, while retaining the essential elements of the previous process and adhering to the objectives of the overall enforcement program. In overlaying this general strategy retroactively on the circumstances given for 1993 and 1994 enforcement cases, the Team estimates that, depending on the judgments applied for individual cases, this strategy would have

---

<sup>21</sup>This is consistent with existing provisions for general discretion, including those given in Sections VII.A and VII.B of the current Enforcement Policy.

<sup>22</sup>Note that, for an SL III problem for a power reactor licensee, with a base CP of \$50,000, the maximum CP normally proposed (base +100%, or \$100,000) would always be within the statutory maximum, even if a single SL III violation had occurred lasting only 1 day.

<sup>23</sup>This proposed process is basically the same as the existing process which, under the current Enforcement Policy, limits the assessed penalty to the statutory maximum, even though the current assessment factors could be applied to arrive at a worst-case penalty (for a single SL I violation) of \$600,000.

resulted in approximately 25% fewer CPs for power reactor licensees, and approximately 45% fewer CPs for materials licensees.

While differences in application and definition of the various factors make this, at best, an inexact analysis, the Team would expect a marked overall reduction in the number of future CPs if this strategy is adopted. More importantly, the Team believes that the added clarity of this proposed strategy will of itself result in fewer CPs, because licensees will better understand the NRC's enforcement focus, more clearly recognize the "paths to success" (i.e., the benefit of identifying and correcting problems, and the level of performance needed to avoid receiving violations and CPs), and, as a result, improve performance.

## **7. Other CP-Related Considerations**

### **a. Mandatory CPs for Certain Types of Events**

The Team considered designating certain types of events as particularly significant, and as such subject to at least a minimum mandatory CP. Under the current Policy, a CP of at least 50% of the base amount is normally proposed for violations involving overexposures, releases of radioactive material in excess of regulatory requirements, or loss of radioactive material. Based on the use of discretion, however (see the discussion under Section II.D.6.d), the Team believes that mandating CPs for certain events is unnecessary.

### **b. Reporting Violations**

The Team believes that the licensee's efforts to promptly report a violation, while commendable, should not be considered as a mitigating factor in assessing any associated CP. The licensee's failure to make a required report, rather than being considered as a factor for escalation, should be considered a separate violation. This conclusion is consistent with the current Enforcement Policy.

### **c. Table 1A, "Base Civil Penalties"**

The Team reviewed Table 1A of the current Enforcement Policy, which lists base CP amounts based on the category of licensee and area of the violation. The table currently lists power reactors and nine other licensee categories. For each category, a base CP amount is given for general SL I violations (in areas such as plant operations, health physics, and emergency preparedness); in addition, special base CP columns are added for safeguards and transportation violations.

The Review Team recommends that the table be simplified to combine categories of licensees with the same base CP amounts. Part 35 licensees (doctors, nuclear pharmacies, and other medical types) should be combined into an overall medical category, based on the similarity of hazards. Moreover, since transportation violations for all licensees are primarily concerned with the potential for personnel exposure to radiation, the Team recommends that CPs for violations in this area be treated the same as in the health physics area.

The \$100,000 base CP amount for safeguards violations, which applies to only two categories of licensees (fuel fabricators or independent fuel and monitored retrievable storage installations) has been deleted. The Team believes that CP amount for safeguards should be the same as for other violation at these facilities. If the CP that would normally be assessed for operational violations is not adequate to address the circumstances of the violation, then discretion may be used to determine the appropriate CP amount.

The Team also recommends that the base CP for "other" materials licensees, currently set at \$1000, be increased to \$5000. The primary concerns for these licensed activities are individual radiation exposure and loss of control of material to the environment, both of which warrant a more financially relevant penalty. The Team believes that a \$500 CP for an SL III violation (at 50% of the SL I base CP) does not reflect the seriousness of this type of violation for this category of licensee.

The proposed table is given below:

**Table 1A - Base Civil Penalty Amounts**

A. Power Reactors . . . . .	\$100,000
B. Fuel Fabricators, Industrial Processors, <sup>1</sup> and Independent Spent Fuel and Monitored Retrievable Storage Installations . . . .	\$25,000
C. Test Reactors, Mills and Uranium Conversion Facilities, Contractors, Vendors, Waste Disposal Licensees, and Industrial Radiographers . . . . .	\$10,000
D. Research Reactors, Academic, Medical, and Other Materials Licensees . . . . .	\$5,000

<sup>1</sup>Large firms engaged in manufacturing or distribution of byproduct, source, or special nuclear material.

The Team acknowledges that each category in this revised table contains a range of licensees, differing individually by size, scope of licensed activities, quantity and type of licensed material, number of employees, number of work locations, and financial assets. The Team believes that no simple classification system will individually account for each of these variables. As with current policy and practice, the NRC should take into account the gravity of the violation and the licensee's ability to pay. If, for a given licensee, Table 1A does not appropriately reflect these factors, the NRC should consider increasing or decreasing the amount as necessary.

*d. Inclusion of Processing and Investigative Costs*

The Team evaluated a proposal to consider processing and fact-gathering (i.e., inspection or investigation) costs for inclusion in the amount of any associated CP. The Team observed, however, that the NRC obtains no financial benefit from the collection of CPs, as the amount goes directly to the United States Treasury general fund. Collection of CPs does not impact NRC appropriations or budget. In addition, including processing and fact-gathering costs could dilute the overall message that the CP was intended to deliver. Therefore, the Team does not support considering these costs in assessing the CP amounts.

**8. Recommendations to the Commission**

The Review Team recommends:

- II.D-1 That the practice of issuing CPs for SL IV violations be discontinued. If an SL IV issue becomes significant enough to warrant a CP, then it should be recategorized at SL III.
- II.D-2 That the Enforcement Policy be modified to incorporate the CP assessment strategy proposed in Section II.D.6 of this report.
- II.D-3 That Table 1A of the Enforcement Policy be modified as proposed in Section II.D.7.c of this report.



## *Section II.E: Other Sanctions*

### *1. Background and Summary of Comments*

Issue F of the August 1994 *Federal Register* notice requested comments on:

- ◆ whether orders and Confirmatory Action Letters (CALs) should be used more or less;
- ◆ when a CAL should be used instead of an order; and
- ◆ whether licensees treat CALs differently than orders.

The Review Team received very few comments in this area. Most commenters who responded at all to this topic stated that the NRC should maintain its current practice. Commenters generally found the use of CALs effective. One commenter felt that, since CALs are not legally binding, their use could be confusing, and should be reduced. Another commenter asked that the NRC restrict the use of CALs to issues of compliance, and not use CALs to promote licensee action outside the regulations.

### *2. Discussion*

The Review Team found the NRC's current use of orders and CALs to be effective. The Team has no recommendations for change in this area.

In a related area, however, the Team recommends a minor change to the Enforcement Policy. Table 2 of the Policy, "Examples of Progression of Escalated Enforcement Actions for Similar Violations in the Same Activity Area Under the Same License," is intended to demonstrate how CPs, orders (for modifying, suspending, or revoking a license), and other sanctions may be combined in graduated degrees of forcefulness when a licensee's performance in receiving SL I, II, and III violations becomes progressively worse. Although Table 2 has been in the Policy since its inception, the Team was unable to find a single instance where it has been expressly used. Moreover, the Team observes that in any case where a licensee's performance approached the standards of noncompliance characterized in Table 2, the NRC would deal with the case on an individual basis. As a result, the Team recommends deleting Table 2 from the Policy.

### *3. Recommendations to the Commission*

The Review Team recommends:

II.E-1 That Table 2 be removed from the Enforcement Policy.

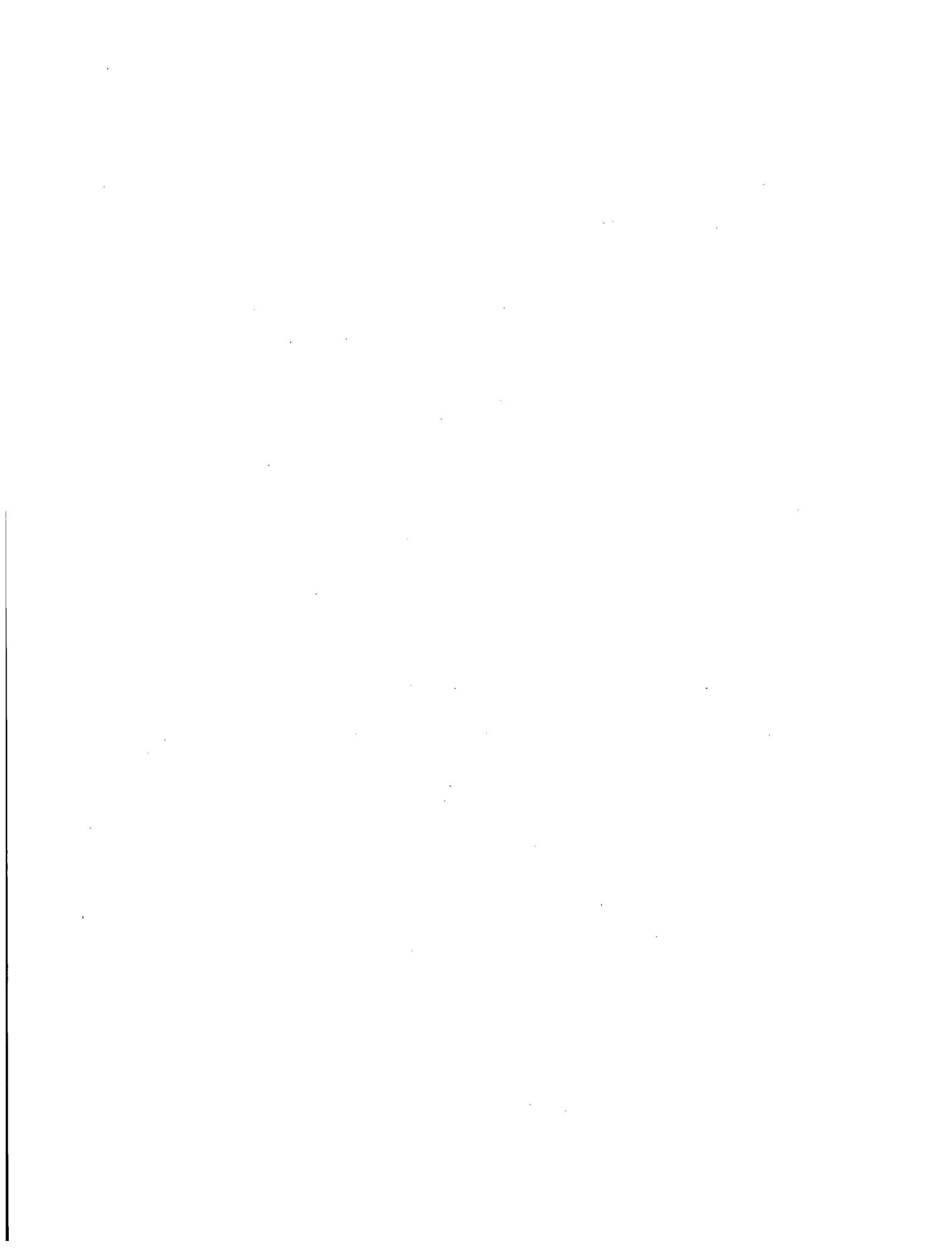

*Section II.F: Violations Involving Willfulness and Individual Wrongdoing**1. Background and Summary of Comments*

Issue I of the August 1994 *Federal Register* notice solicited comments on violations involving willfulness and actions against individual wrongdoers. The NRC Enforcement Policy identifies willful violations by NRC licensees, their contractors or vendors, to be of particular concern, and provides for escalated enforcement action in such instances through an increase in the severity level based on willfulness. The Review Team sought comments on:

- ◆ whether the current Enforcement Policy appropriately reflects the seriousness of willful violations;
- ◆ whether sufficient guidance exists on developing sanctions against licensees for willful violations;
- ◆ whether sufficient guidance exists on developing sanctions against individuals for wrongdoing;
- ◆ whether sanctions against individuals should be accompanied by sanctions against the relevant licensee, and if so, the criteria to be used;
- ◆ the appropriateness of applying various sanctions to willful violations, and the criteria to be used for each; and
- ◆ when discretion should be exercised for willful violations.

Commenters were evenly divided as to whether the current willfulness policy is sufficient. Commenters generally favored using higher CPs where willfulness is substantiated, and stated that criminal sanctions should be reserved for those cases in which egregious violations were committed with obvious malice. Some commenters opined that criminal sanctions are sometimes weak, and are not used often enough to serve as a deterrent or to provide a signal of ultimate accountability. On the other hand, some felt that too many violations carried the threat of criminal sanctions, and that fear of criminal culpability had a chilling effect on taking responsible action, as well as discouraging people from coming forward with safety concerns.

Most commenters felt that NRC guidance could benefit by improving the clarity of concepts such as wrongdoing, willfulness, criminal culpability, and the wrongdoer rule. Commenters also suggested the need to clarify "due process" in cases involving Demands for Information (DFIs), NOVs, Letters of Reprimand (LORs), or orders to individuals. Some commenters felt that good examples of these concepts would assist in implementing the process, and should be included in the guidance.

Commenters were strongly divided on whether the NRC should use the wrongdoer rule to issue sanctions against individuals as well as licensees. Some felt that the wrongdoer rule was underused against individuals, and that where justified it should be followed by action against the licensee as well. Others were opposed to any accountability by individuals. The majority, however, felt that licensees should not be held accountable when an individual is clearly responsible for a willful violation, and that penalizing a licensee who has acted responsibly in such situations provides no meaningful incentive or deterrent effect.

Commenters generally agreed that, where wrongdoing violations are substantiated, the NRC might legitimately use any of the sanctions currently available. Nearly all commenters supported using discretion, as appropriate, in the treatment of wrongdoing violations. One commenter stated that discretion should never be used for willful violations.

## **2. Discussion**

The Review Team believes that no substantial changes are needed in this area. The current Enforcement Policy reflects the significance of wrongdoing and willful violations within the regulatory process. Substantiated willfulness by licensees or individuals should result in increasing the severity level of the underlying violation. Existing mechanisms for addressing wrongdoing issues appear to be adequate, and appropriate flexibility exists to exercise discretion when warranted to provide the appropriate regulatory message. The Team believes that NRC should continue to use sanctions directly or indirectly against individuals, as warranted, to emphasize that willful violations are not acceptable in the nuclear industry. The Team also recognizes the need for careful judgment when developing sanctions in this area.

As characterized by longstanding practice, the NRC will generally take action against a licensee when a violation is caused by the licensee's employee. This practice reflects the fundamental concept that an NRC license is issued not only to licensee management, but to the entity as a whole. The Review Team believes the Enforcement Policy should emphasize that, by taking action against individuals, the NRC ". . . does not intend to diminish the responsibility of a licensee for the conduct of its employees and therefore, as appropriate, the Commission also will be taking action against the licensee directly."<sup>1</sup>

For more significant willful violations, Section VIII of the Policy gives nine factors to be considered in determining whether the enforcement action should be focused primarily on the licensee or the individual. Action should normally be considered against both the individual and the licensee; for more significant willful violations, the licensee should

---

<sup>1</sup>From the Statement of Considerations for the rule on Deliberate Misconduct (56 FR 40664, 40666, August 15, 1991).

generally be issued at least an NOV, regardless of whether action is also taken against the individual. The Team notes, however, that the current Policy suggests that an evaluation of the nine culpability factors might result in issuing the enforcement action to an unlicensed individual "rather than to the licensee" [italics added]. This implication--that the individual action may be taken *in lieu of* action against the licensee--is inconsistent with the original rulemaking.<sup>2</sup>

The Team finds it important to recognize, as the Commission held in the *Atlantic Research* decision, that the NRC does not specifically license the management or the employees of a company. The NRC licenses the *entity*. The licensee is responsible for the possession and uses of licensed material. The licensee is the entity that hires, trains, and supervises the employees. It obtains the benefits of their good performance and suffers the consequences of their poor performance. Not holding the licensee responsible for the actions of its employees, whether negligent or willful, is tantamount to saying that the licensee is not responsible for the possession and use of the licensed material. Therefore, the Team recommends that the Policy be changed to clarify that enforcement action should be considered against both the individual and the licensee.<sup>3</sup>

Recommendation II.C-2 emphasized that predecisional enforcement conferences should be normally held only if a regulatory need exists or upon a licensee's request. For individual enforcement actions, the Team recommends that individuals normally be given the opportunity to attend a conference before an enforcement order is issued unless the individual has been given a prior opportunity to explain his or her position such as in the response to a DFI. Exceptions to this recommendation are appropriate where action is required to be made immediately effective based on public health and safety.

For individual cases involving NOV's, DFIs, and LORs, the individual subject to the action should be given an opportunity to dispute the action. This opportunity may be given within the document, or may be given prior to the enforcement action such as during a predecisional enforcement conference or previously issued DFI. In any event, it should occur before the NRC places the action in the PDR. As a result of comments, OE is currently clarifying this area to better explain how individuals can respond to and question

---

<sup>2</sup>*Id* at 40680 and 40687.

<sup>3</sup>Again, however, decisions in this area are discretionary. Whether action should be taken against only the employee, only the licensee, or both the employee and the licensee requires the exercise of judgment after considering all the facts and circumstances of the particular case. For example, enforcement action against the licensee may be inappropriate when an employee commits a willful violation on a "frolic of his own," without intent to further the licensee interest. This would be particularly true if no indication exists that licensee management was involved in any way in supporting, condoning, or reinforcing such actions, and if strong and appropriate action was taken when the matter was identified.

the issuance of DFIs or LORs. Normally a member of the NRC staff is listed as a contact should the person subject to the action have questions on it.

As to defining willfulness, the Team notes that the Rule on Deliberate Misconduct (e.g., 10 CFR 50.5) provides a definition as to what is considered deliberate misconduct. In addition, the Statements of Consideration for that rule help to clarify the concept of deliberate misconduct (56 *FR* 40684, August 15, 1991). The Team recognizes that many of these terms, in an NRC regulatory framework, are used in a specific context and as such are difficult to define.

Finally, as to whether violations of NRC requirements should subject a person to criminal sanctions, that issue is answered by Section 223 of the AEA. Section 223 provides that willful violations of those NRC requirements promulgated under Section 161.b, 161.i, and 161.o are criminal.

### **3. *Recommendations to the Commission***

The Review Team recommends:

- II.F-1 That the NRC normally provide an opportunity for a predecisional enforcement conference with an individual before issuing an order or civil penalty, except where the public health and safety requires immediate action.
- II.F-2 That the Enforcement Policy be clarified to provide that the nine factors used in evaluating individual actions pertain to whether enforcement actions should be issued to an individual as well as to the applicable licensee. In cases of significant wrongdoing, some action normally should be taken against the licensee.

### *Section II.G: Implementation, Delegation, and Oversight*

The Team observed that most commenters favored increased consistency and predictability in the enforcement program, supported centralized review of escalated enforcement decisions, and opposed further delegation of escalated actions to Regional Administrators or below. As presented in Section II.D.6 and elsewhere, the Team's proposed changes to the escalated enforcement process were based in part on producing consistent, predictable enforcement decisions; in addition, the changes propose a more streamlined decisional approach.

While the proposed changes simplify the process by reducing the number of decision points, the Team has been careful to explain the need for judgment at each point, and the need to exercise discretion when considering unusual cases. Balancing this use of judgment and discretion with the goal of consistency and predictability will require continued national oversight of the escalated enforcement process, especially for larger or more unique sanctions. On the other hand, the streamlined nature of the overall process justifies giving greater responsibility to the regions.

#### *1. Staff Oversight*

##### *a. Current Approach*

Under the current Policy, the Office of Enforcement (OE) is responsible for centralized management of the agency enforcement process. At the SL IV and V level, violations are issued by the regions with essentially no prior OE consultation. If a licensee disputes a violation, it is normally reviewed at a higher level within the regional office.<sup>1</sup> If a dispute cannot be resolved within 60 days at the regional office or if the licensee continues to dispute the violation after receiving the regional response, the matter should be reviewed by OE, which involves the program office and the Office of General Counsel (OGC) as needed. The Review Team finds this review process appropriate.

For escalated actions, cases are either designated as delegated or non-delegated. For routine materials cases at SL III, the regions have been delegated authority to issue NOV's and proposed CPs. Prior consultation with OE is not required, but cases are frequently discussed with OE on consistency and policy matters. OE reviews each delegated escalated case after issuance by the regions.

---

<sup>1</sup>Note that if the licensee's dispute is based on a contention that the Enforcement Policy is being inappropriately applied, the case should be referred to OE.

For non-delegated materials cases (e.g., willful cases, unusual cases), fuel cycle cases, and all escalated reactor cases, the region provides the proposed action to OE for formal review and coordination. OE coordinates its review with OGC, the appropriate program office (NRR or NMSS), and when needed, the appropriate Deputy Executive Director for Operations (DEDO). On appeal, responses to escalated actions are submitted to OE, and OE independently reviews all orders, including orders imposing CPs. Such actions are again coordinated with the appropriate program office, OGC, and the DEDO.

Before issuing any escalated case involving an order or CP, the Commission is informed of the action by the issuance of an Enforcement Notification (EN). This is usually sent 3 days before the initial case is dispatched, and a copy is placed in the PDR after the licensee has been informed of the action. The EN provides an opportunity for the Commission to question a case before issuance. In addition, the staff consults with the Commission before issuing certain cases, as described below.

***b. Proposed Changes***

The Review Team believes that the delegation for the routine materials cases should not be changed. With the new proposed enforcement strategy, which simplifies the CP assessment process, the Review Team recommends that the process for OE's formal review and coordination of non-delegated escalated cases be changed. The Team recommends that OE oversight be preserved, but that it be focused on the enforcement strategy, severity levels, the violations, and enforcement policy. In most cases OE should focus the Headquarters review on the inspection report and draft NOV, leaving the actual correspondence to the regions. After the action has been issued, OE should, in its audit and appeal role, review the actual correspondence.

Under the revised approach, the region would contact OE when regional management believes that escalated action may be warranted. Consultation with OE should normally occur by a conference call involving the region, OE, and as appropriate, NRR or NMSS management (OGC should be included when willfulness or other legal issues are involved). The purpose of this call is to review the apparent violations, their associated severity levels, the initial application of the assessment factors, and the need for a predecisional enforcement conference. The discussion should also determine if the case involves non-routine issues such as willfulness, unusual or generic issues, or is a candidate for exercising discretion outside the normal assessment strategy.

This call will assist in providing interregional consistency on categorizing severity levels and applying the identification factor and associated issues (i.e., treatment of



events, missed opportunities, and mixed identification issues). For most cases, the written enforcement action need not be formally submitted to OE for review. The region would process and issue the case, accompanied by the appropriate EN. Some cases will still be formally submitted to OE for Headquarters review, including cases involving discretion or non-routine issues, significant legal issues, matters requiring orders or Commission consultation, situations of substantial disagreement among the region, OE, and the program office, or issues for which the region requests Headquarters review.

If a predecisional enforcement conference is held, the region should again consult with OE to discuss whether new information or perspectives were obtained warranting reconsideration of the enforcement approach for the case. That consultation should include, among other things, the reasonability of the licensee's corrective action.

The Review Team believes that this approach will provide the necessary oversight to achieve a relatively consistent enforcement program, while obtaining the benefits of the streamlined approach.

## **2. *Dissemination of Significant Enforcement Actions***

NRC enforcement actions have long been public documents. Since 1982, the staff has published, on a quarterly frequency, NUREG-0940, "Enforcement Actions: Significant Actions Resolved." This publication provides licensees and the public with copies of escalated enforcement actions, including actions taken against individuals who have violated the requirements against deliberate misconduct. Having a compilation of enforcement actions in a ready reference has assisted the staff in maintaining a consistent approach across the regions. The NUREG is distributed to many of the Commission's licensees, informing them of the failures of other licensees in the interest of avoiding similar significant noncompliance issues.

The Review Team concludes that this NUREG should be continued. However, the Team also recommends that OE place newly issued escalated enforcement actions on the NRC's electronic bulletin board system, to more efficiently inform other licensees of significant enforcement actions, in the interest of avoiding similar failures. The Team recommends that the cases be placed into the electronic Bulletin Board after they have been placed in the NRC PDR. Once this system is operational, OE should reduce the frequency of NUREG-0940 to semiannual.

Since 1994, NUREG-0940 has been divided into three parts: reactors, medical, and industrial licensees. This has allowed a more focused distribution to the interested

licensees. NMSS also issues a newsletter to its licensees that summarizes significant enforcement actions taken. The Team recommends that OE and NMSS reconsider the distribution of NUREG-0940 to materials licensees, and evaluate whether better ways exist of communicating significant enforcement actions to these licensees, especially the smaller licensees.

### 3. *Commission Consultation*

Most enforcement decisions are made at the staff level; however, based on guidance given in Section III of the Enforcement Policy, "Responsibilities," certain situations require formal Commission consultation. The practice of providing Commission consultation has existed since the Enforcement Policy was first published as an interim Policy in 1980. Since then, the number of criteria requiring this consultation has more than doubled.

The Review Team believes that there may be less need now for mandatory Commission involvement. Most of the criteria for consultation were adopted in earlier years, to address particular Commissioner concerns or areas where the staff had little experience. As currently administered, the staff has had substantial experience in implementing the objectives of the Enforcement Policy, and it is relatively rare that the Commission changes the recommended staff approach. Senior NRC management is sensitive to issues of Commission concern. The Office of Enforcement is positioned to closely coordinate enforcement action reviews with senior regional and program office management, as well as with the EDO and DEDOs, when necessary.

Based on these factors, and considering the significant effort currently expended in providing Commission consultation on enforcement matters, the Review Team recommends that the staff be given more flexibility to decide what enforcement issues should be brought to the Commission's attention because of policy significance, controversy, or known Commission interest. As part of this recommendation, the Team believes that OE should prepare a annual report summarizing significant actions taken, cases where the exercise of discretion resulted in deviating from standard practice, needed policy changes, audit results, timeliness data, and other enforcement issues that may be of interest to the Commission.<sup>2</sup> This report should also replace the monthly and quarterly timeliness reports provided to the Commission.

As stated earlier, Section III of the Enforcement Policy currently requires Commission consultation prior to taking action in ten specific situations (unless the urgency of the

---

<sup>2</sup>To be useful, this report will provide predecisional information, and should not be publicly disclosed without Commission approval.

situation dictates immediate action). These situations, with the Team's recommended changes, are discussed below:

- (1) Description: "An action affecting a licensee's operation that requires balancing the public health and safety or common defense and security implications of not operating with the potential radiological or other hazards associated with continued operation;"

Recommendation: This provision has existed since 1980 and the Team believes that it should be maintained, based on scope and significance.

- (2) Description: "Proposals to impose civil penalties in amounts greater than 3 times the Severity Level I values shown in Table 1A;"

Recommendation: The basic requirement to consult with the Commission before issuing large CPs has existed since 1980 and has been modified several times. The Team agrees with the importance of consulting with the Commission in these cases, but would clarify the existing provision to indicate that the CPs in question are those issued for a single violation or problem.

- (3) Description: "Any proposed enforcement action that involves a Severity Level I violation;"

Recommendation: This provision was first introduced in the 1984 Policy revision. Because these cases involve the most significant level of violations and occur on an infrequent basis, the Team believes it is appropriate to continue to consult with the Commission before their issuance.

- (4) Description: "Any enforcement action that involves a finding of a material false statement;"

Recommendation: This provision was first introduced in the 1984 Policy revision. The description of a communication failure as a material false statement is reserved for egregious violations and is made on a case-by-case basis. Because of the egregious nature of these cases, it is logical that they would be considered very significant regulatory concerns and likely categorized at SL I. Because the staff is already required to consult with the Commission on cases involving SL I violations, the Team believes that it is not necessary to include this specific provision.

- (5) Description: "Exercising discretion for matters meeting the criteria of Section VII.A.1 for Commission consultation;"

Recommendation: This provision was first introduced in the 1992 Policy revision. Section VII.A.1 provides added flexibility in the CP assessment process, and requires Commission consultation if the difference between the amount of the CP proposed under this discretion and the amount of the CP assessed under the normal process is more than two times the base CP value given in Table 1A or 1B. Given the staff's experience in implementing the Commission's enforcement program objectives--including the exercise of discretion--the Team believes that each case should be judged on its own merits to determine whether Commission consultation is warranted, rather than routinely requiring it.

- (6) Description: "Refraining from taking enforcement action for matters meeting the criteria of Section VII.B.3;"

Recommendation: This provision was first introduced in the 1987 Policy revision. Section VII.B.3 addresses violations identified during extended shutdowns or work stoppages. Given the staff's experience in implementing the Commission's enforcement program objectives, including the exercise of discretion, the Team believes that each case should be judged on its own merits to determine whether Commission consultation is warranted, rather than routinely requiring it.

- (7) Description: "Any proposed enforcement action that involves the issuance of a civil penalty or order to an unlicensed individual or a civil penalty to a licensed reactor operator;"

Recommendation: This provision was first introduced in the 1991 Policy revision. The Team believes this criterion should be deleted. Given the staff's experience in implementing the Commission's enforcement program objectives on issuing orders to individuals, the Team believes that each case should be judged on its own merits to determine whether Commission consultation is warranted, rather than routinely requiring it. The Team also observes that, under the current Policy, CPs are not normally issued to unlicensed individuals or operators, and any such case would receive Commission consultation under Criterion 8, below.

- (8) Description: "Any action the EDO believes warrants Commission involvement;"

Recommendation: The Review Team believes it is appropriate to maintain this provision.

- (9) Description: "Any proposed enforcement case involving an Office of Investigations (OI) report where NRC staff (other than OI staff) does not arrive at the same conclusions as those in the OI report concerning issues of intent if the Director of OI concludes that Commission consultation is warranted;"

Recommendation: This basic provision was first introduced in the 1992 Policy revision and recently modified in a 1994 revision. The Review Team believes that it is appropriate to maintain this provision.

- (10) Description: "Any proposed enforcement action on which the Commission asks to be consulted."

Recommendation: This provision has existed since 1980, and the Review Team believes it should be maintained.

In addition to these changes to Section III of the Policy, the Team notes that the Enforcement Policy currently requires that the Commission be provided advance notification of: (1) all enforcement actions involving CPs or orders; (2) those cases where discretion is exercised as discussed in Section VII.B.6 of the Policy (i.e., reducing or refraining from issuing a CP or an NOV for an SL II or III violation where the staff concludes that application of the normal guidance in the Policy is unwarranted); and (3) certain actions against unlicensed individuals and persons described in Section VIII. The Review Team believes that it is appropriate to continue to notify the Commission of actions involving CPs and orders by way of the EN process. Given the experience the staff has had in implementing the objectives of the Commission's enforcement program and exercising discretion, the Review Team recommends that these mandatory notification provisions be removed. Instead, the Review Team recommends that the staff address the use of discretion in the proposed annual report, or as warranted when the staff believes that the Commission should be aware of a particular issue.

By Staff Requirements Memorandum (SRM) dated December 23, 1991, the Commission directed that any escalated action related to maintenance programs be sent to the Commission for a "negative consent" review. The SRM direction was implemented by Enforcement Guidance Memorandum (EGM) 92-01T (January 2, 1992).<sup>3</sup> This provision applies to programmatic maintenance failures, and does not refer to failures to follow maintenance procedures or failures to perform post-maintenance testing. The Review Team recommends that each such case be judged on its own merits to determine whether Commission consultation is warranted, rather than routinely requiring it.

---

<sup>3</sup>See *NRC Enforcement Manual*, Appendix A-3.

#### 4. *Placement of the Enforcement Policy in the Code of Federal Regulations*

The Enforcement Policy is one of only two Commission policy statements published in the Code of Federal Regulations (CFR).<sup>4</sup> In the years since inception of the Policy, the Commission has repeatedly emphasized that the Enforcement Policy should be considered guidance, rather than a rule, and that considerable flexibility exists in implementing the Policy. Despite its status as a policy statement, however, the Commission has chosen to keep it in the CFR for wide dissemination, so that the industry and the public have ready access to the principles and guidance used in NRC enforcement.

The preface to the Policy states that it ". . . is a policy statement and not a regulation. The Commission may deviate from this statement of policy and procedure as appropriate under the circumstances of a particular case." While the guidance of the Policy is generally followed, the need to exercise judgement is emphasized throughout the Policy. For example, Section III of the Policy provides:

In recognition that the regulation of nuclear activities in many cases does not lend itself to a mechanistic treatment, judgment and discretion must be exercised in determining the severity levels of the violations and the appropriate enforcement sanctions, including the decision to issue a Notice of Violation, or to propose or impose a civil penalty and the amount of this penalty, after considering the general principles of this statement of policy and the technical significance of the violations and the surrounding circumstances.

Similarly, Section IV of the Policy, in explaining the use of the severity examples in the eight supplements, states:

Supplements I through VIII provide examples and serve as guidance in determining the appropriate severity level for violations in each of the eight activity areas. However, the examples are neither exhaustive nor controlling. In addition, these examples do not create new requirements. Each is designed to illustrate the significance that the NRC places on a particular type of violation of NRC requirements. Each of the examples in the supplements is predicated on a violation of a regulatory requirement.

---

<sup>4</sup>The other such policy statement is Appendix A to 10 CFR Part 2, "Statement of General Policy and Procedure: Conduct of Proceedings for the Issuance of Construction Permits and Operating Licenses for Production and Utilization Facilities for Which a Hearing is Required Under Section 189A of the Atomic Energy Act of 1954, as Amended." Whether that appendix should be removed from the CFR or other appropriate action taken is not within the scope of the Review Team's assessment.

The NRC reviews each case being considered for enforcement action on its own merits to ensure that the severity of a violation is characterized at the level best suited to the significance of the particular violation. In some cases, special circumstances may warrant an adjustment to the severity level categorization.

The Commission's reason for having a policy statement rather than a rule was explained in the Statement of Consideration that accompanied the publication of the 1982 Enforcement Policy. The Commission stated then:

An underlying basis of this policy that is reflected throughout it is that the determination of the appropriate sanction requires the exercise of discretion such that each enforcement action is tailored to the particular factual situation. In view of the discretion provided, the enforcement policy is being adopted as a statement of general policy rather than as a regulation, notwithstanding that the statement has been promulgated with notice and comment procedures. A general statement of policy will permit the Commission maximum flexibility in revising the policy statement and it is expected that the statement, especially the supplement, will be revised as necessary to reflect changes in policy and direction of the Commission (47 FR 9989, March 9, 1992).

For similar reasons, the Review Team continues to believe that the Enforcement Policy should remain as a general statement of policy rather than a regulation. As noted, however, the Enforcement Policy is published in the CFR. At least one court, in considering whether an enforcement policy was a policy statement or a regulation, noted that if the policy was published in the CFR, it would be proper to treat it as a regulation, because the CFR is reserved for documents "having general applicability and legal effect."<sup>5</sup> Therefore, the Review Team recommends that the Enforcement Policy when next issued should be removed from the CFR. Revisions should continue to be published in the *Federal Register*. To ensure widespread dissemination, the Team recommends that the current version of the Policy be made available on the electronic bulletin board and in NUREG-0940.

##### 5. *Timeliness of Enforcement Actions*

The Review Team recognizes the concerns expressed about timeliness of escalated cases. In respect to the changes proposed for escalated enforcement action, the Team expects that these changes should result in improvements in timeliness for most escalated cases without a corresponding reduction in quality. More significant cases, however, especially those

---

<sup>5</sup>*Brock v. Cathedral Bluffs Shale Oil Co.*, 796 F.2d, at 533, 539 (D.C. Cir. 1986) citing 44 U.S.C. 1510 (1982).

requiring the exercise of discretion and Commission consultation, will take time to process properly.

In addition, many of the concerns about timeliness are related to cases involving wrongdoing. The Office of Investigations is making progress in improving the timeliness of its investigations. In some cases, delay of NRC enforcement actions is caused by the necessary time for the Department of Justice to reach decisions on whether to prosecute cases as provided for in the Memorandum of Understanding between the NRC and DOJ.<sup>6</sup> While the agency should continue efforts to improve the timeliness of significant enforcement actions, the Team does not believe that timeliness should be improved at the expense of weakening the quality of fact-finding, evaluation, and/or decision-making.

## 6. Recommendations

### a. Recommendations to the Commission

The Review Team recommends:

II.G-1 That the Enforcement Policy be revised to require prior consultation with the Commission for:

- (1) An action affecting a licensee's operation that requires balancing the public health and safety or common defense and security implications of not operating with the potential radiological or other hazards associated with continued operation;
- (2) Proposals to impose civil penalties for a single violation or problem in amounts greater than 3 times the Severity Level I values shown in Table 1A;
- (3) Any proposed enforcement action that involves a Severity Level I violation;
- (4) Any proposed enforcement case involving an Office of Investigations (OI) report where the staff (other than the OI staff) does not arrive at the same conclusions as those in the OI report concerning issues of intent, if the Director of OI concludes that Commission consultation is warranted; and

---

<sup>6</sup>53 FR 50317 (December 14, 1988).



- (5) Any action the EDO believes warrants Commission involvement; and
- (6) Any proposed enforcement action on which the Commission asks to be consulted.

II.G-2 That OE prepare an annual report summarizing significant actions taken, cases where the exercise of discretion resulted in deviating from standard practice, needed policy changes, audit results, and other enforcement issues that may be of interest to the Commission. This report should also replace the monthly and quarterly timeliness reports provided to the Commission.

II.G-3 That the Enforcement Policy, when next issued, should be removed from the CFR.

***b. Recommendations to the Staff***

The Review Team recommends:

II.G-4\* That the staff revise the process for Headquarters oversight of escalated actions, as described in Section II.G.1.b of this report.

II.G-5\* That OE begin publishing significant enforcement actions on an NRC electronic bulletin board, reduce the frequency of publishing NUREG-0940 to semiannual, and evaluate with NMSS more appropriate methods of disseminating significant enforcement findings to materials licensees.



## *Part III: Summary and Recommendations*

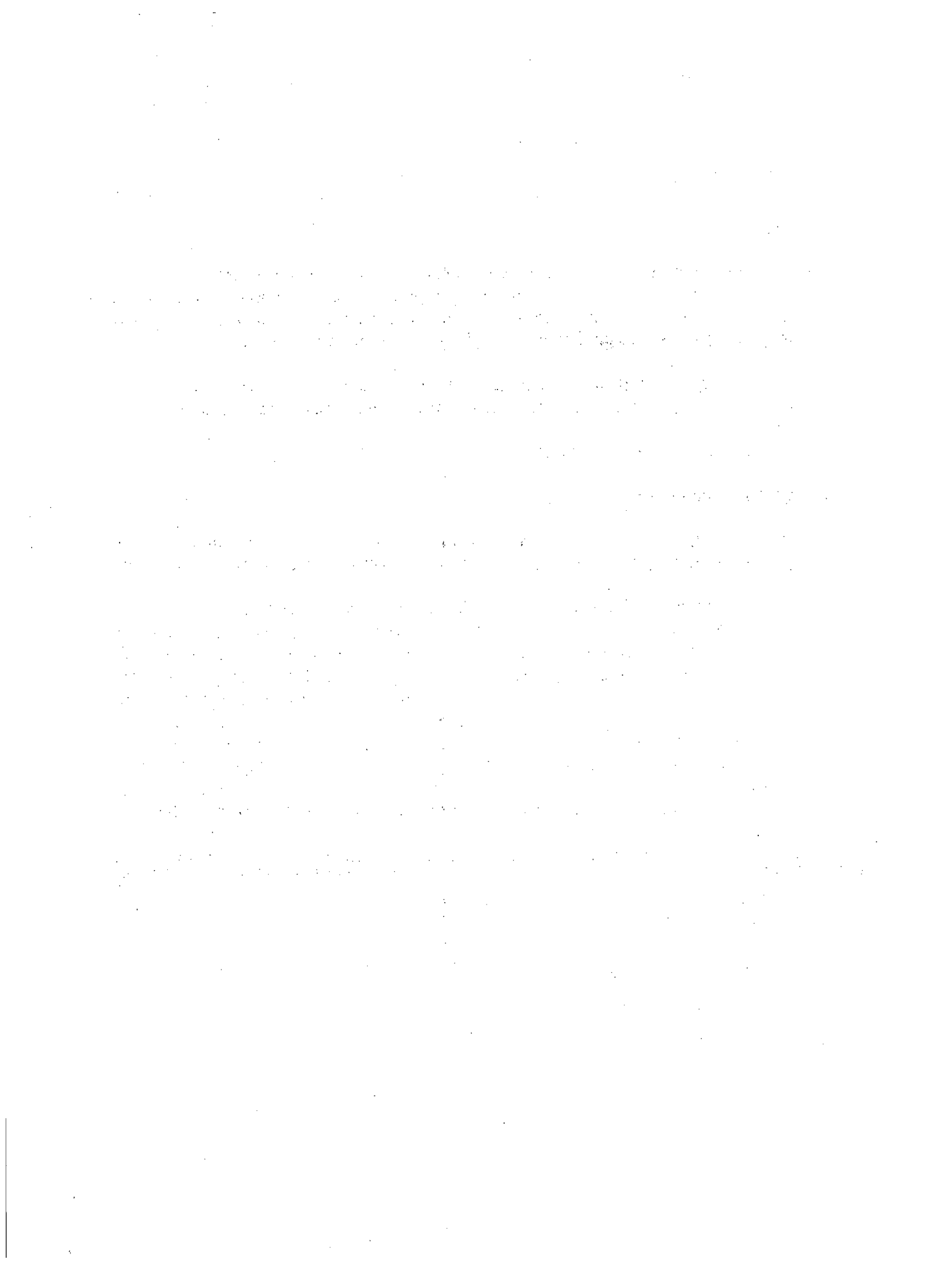

**Section III.A: Conclusions****1. General Assessment of the Current Program**

The Review Team concludes that the existing NRC enforcement program, as implemented, is appropriately directed toward supporting the agency's overall safety mission. This conclusion is reflected in several aspects of the program:

- ◆ The Policy recognizes that violations have differing degrees of safety significance. As reflected in the severity levels, safety significance includes actual safety consequence, potential safety consequence, and regulatory significance. The use of graduated sanctions, from Notices of Violation to orders, further reflects the varying seriousness of noncompliances.
- ◆ The enforcement conference is an important step in achieving a mutual understanding of facts and issues before making significant enforcement decisions. While these conferences take time and effort for both the NRC and licensees, they generally contribute to better decision-making.
- ◆ Enforcement actions deliver regulatory messages properly focused on safety. These messages emphasize the need for licensees to identify and correct violations, to address the root causes, and to be responsive to initial opportunities to identify and prevent violations.
- ◆ The use of discretion and judgment throughout the deliberative process recognizes that enforcement of NRC requirements does not lend itself to mechanistic treatment.

The Review Team also finds, however, that the existing program at times provided mixed regulatory messages to the licensees, and room for improvement existed in both the Enforcement Policy and implementation. The Team believes that the overall program focus should be clarified as follows:

- ◆ Emphasize the importance of identifying problems before events occur, and of taking prompt, comprehensive corrective action when problems are identified;
- ◆ Direct agency attention at licensees with multiple enforcement actions in a relatively short period; and
- ◆ Focus on current performance of licensees.

In addition, the Team believes the process can be simplified to improve the predictability of decision-making and obtain better consistency between regions. Implementation improvements can improve timeliness and increase the efficiency of the deliberative process without adversely affecting either the effectiveness or consistency of the overall enforcement program.

## **2. *Significant Observations and Recommendations***

The scope of the Team's review included the entire range of NRC enforcement actions. However, few substantive proposals were made related to orders, Confirmatory Action Letters, violations involving willfulness and individual wrongdoing, or timeliness of enforcement actions. Substantial recommendations were primarily focused on the areas of enforcement philosophy, Notices of Violation, civil penalties, and enforcement conferences.

### **a. *Purpose of the Enforcement Program***

The purpose of the NRC enforcement program should be clarified. The program should supplement the NRC's overall safety mission in protecting the public, workers, and the environment. Consistent with that purpose, enforcement actions should be used to create deterrence by: (1) emphasizing the importance of compliance with requirements, and (2) encouraging prompt identification and prompt, comprehensive correction of violations.

### **b. *Use of Graduated Enforcement Sanctions***

The NRC should continue to use a graduated system of enforcement actions, in a manner that reflects the varying safety significance of different violations, and which can be adjusted based on the circumstances of the violation.

The NRC's enforcement efforts should be focused most on matters of greatest safety significance. In the broadest sense, this focus should be directed at SL I and II violations, licensees with multiple SL III problems, and willful violations.

SL V violations should be eliminated. Formal enforcement actions should only be taken for violations categorized at SL I to IV, to better focus the inspection and enforcement process on safety. Minor violations, if documented, should be treated as Non-Cited Violations.

*c. Increased Clarity*

The NRC's Enforcement Policy should be designed to convey clear regulatory messages, and should attempt to minimize the number and complexity of decision points. The Policy should be simplified to ensure, where possible, a consistent and predictable result. While the need remains for judgment and discretion, this change should reinforce the overall objectives of the enforcement program and highlight the actions expected of licensees in order to avoid civil penalties (i.e., identifying and correcting violations before events occur).

*d. Enforcement Conferences*

To emphasize their status as part of the deliberative process, enforcement conferences should be renamed "predecisional enforcement conferences." These conferences should be considered when the agency reasonably expects that an escalated enforcement action will result, and held when additional information is needed to make an enforcement decision. They should also normally be held if requested by a licensee.

Predecisional enforcement conferences should normally be public meetings held in regional offices. The intent of open conferences is not to maximize public attendance, but rather to provide the public with an opportunity to observe the regulatory process. Conferences should be announced in a manner consistent with other NRC open meetings. Press releases should not normally be used.

*e. Civil Penalties: General Philosophy*

Applied with discretion and judgment, civil penalties (CPs) can provide an additional effective deterrent against future violations, by: (1) emphasizing the importance of adherence to requirements; and (2) reinforcing those aspects of licensee performance that are especially crucial in ensuring quality (e.g., self-identification of problems and root causes, prompt and comprehensive correction of errors, and recognition and avoidance of adverse trends).

With limited exceptions, maintaining the existing base CP amounts should result in meaningful civil penalties, and should allow meaningful differentiation between violations of varying significance. In addition, increasing the incentives for strong self-monitoring and corrective action programs could be better accomplished by revising the overall CP assessment process, as discussed below, than by raising the base CP amounts.

*f. Civil Penalties: Revised Assessment Process*

Once a violation has been determined to be SL III or above, the CP assessment strategy should consist, at most, of four basic decisional points: (1) whether the licensee has had a previous escalated enforcement action during the past 2 years or past 2 inspections, whichever is longer; (2) whether the licensee should be given credit for actions related to identification; (3) whether the licensee's corrective actions may reasonably be considered prompt and comprehensive; and (4) whether, in view of all the circumstances, the case in question requires the exercise of discretion. While each of these decisional points may have several associated considerations for any given case, the outcome of that case, absent the exercise of discretion, should be limited to three outcomes: no CP, a base CP, or a base CP +100%.

*(1) Initial Escalated Action*

When the NRC determines that a non-willful SL III violation has occurred, and the licensee has not had a previous escalated action during the past 2 years or 2 inspections, the only consideration should be whether the licensee's corrective action for the present violation may reasonably be considered prompt and comprehensive (see discussion under (3), below).

If the corrective action is judged to be prompt and comprehensive, the Notice of Violation should be issued with no associated CP. If the corrective action is judged to be less than prompt and comprehensive, the Notice of Violation should be issued with a base CP.

*(2) Credit for Actions Related to Identification*

If an SL I or II violation or a willful SL III violation has occurred--or if, during the past 2 years or 2 inspections, the licensee has been issued at least one other escalated action--additional factors should be considered in the CP assessment. The first of these is whether the licensee should be given credit for actions related to identification. This decision requires considering who identified the problem, whether the problem resulted in an event, the ease of discovery, the degree of licensee initiative shown, whether prior opportunities existed to identify the problem, and other similar factors. The following general guidance is provided:

- ◆ When a problem requiring corrective action is licensee-identified (i.e., identified before the problem has resulted in an event), the NRC should normally give the licensee credit for actions related to identification,



regardless of whether prior opportunities existed to identify the problem.

- ◆ When a problem requiring corrective action is identified through an event, the decision on whether to give the licensee credit for actions related to identification should consider the ease of discovery, whether the event occurred as the result of a licensee self-monitoring effort (i.e., whether the licensee was "looking for the problem"), the degree of licensee initiative in identifying the problem or problems requiring corrective action, and whether prior opportunities existed to identify the problem. Any of these considerations may be overriding if particularly noteworthy or particularly egregious.
- ◆ When a problem requiring corrective action is NRC-identified, the decision on identification credit should be based on whether the licensee should reasonably have identified the problem (and taken action) earlier.
- ◆ For "mixed" identification situations (i.e., where multiple violations exist, some NRC-identified, some licensee-identified), the NRC's evaluation should determine whether the licensee could reasonably have been expected to identify the violation in the NRC's absence.

When the NRC determines that the licensee should receive credit for actions related to identification, the CP assessment should normally result in either no CP or a base CP, based on whether corrective action is judged to be reasonably prompt and comprehensive. When the licensee is not given credit for actions related to identification, the same judgment on corrective action should normally result in either a base CP or a base CP + 100%.

### ***(3) Credit for Prompt and Comprehensive Corrective Action***

This factor encourages licensees to (1) take the immediate actions necessary upon discovery of a violation that will restore safety and compliance with the requirement; and (2) develop and implement (in a timely manner) the lasting actions that will not only prevent recurrence of the violation at issue, but will be appropriately comprehensive, given the significance and complexity of the violation, to prevent occurrence of violations with similar root causes.

In assessing this factor, consideration will be given to the timeliness of the corrective action, the adequacy of the licensee's root cause analysis, and, given the significance and complexity of the issue, the comprehensiveness of the corrective

action (i.e., whether the action is focused narrowly to the specific violation or broadly to the general area of concern). Even in cases where the NRC, at the time of the predecisional enforcement conference, identifies additional peripheral or minor corrective action still to be taken, the licensee may be given credit in this area, as long as the licensee's actions addressed the underlying root cause and are considered sufficient to prevent recurrence of the violation and similar violations.

**(4) *Exercise of Discretion***

The ability to exercise discretion (in tailoring sanctions to the circumstances of each case) must be preserved. The recommended approach provides for the use of discretion to deviate from the normal approach where necessary to ensure that the sanction reflects the significance of the circumstances and conveys the appropriate regulatory message.

**g. *Implementation***

In implementing the Enforcement Policy, the need for agency-wide consistency should be balanced against the resource cost of implementing the program. While no changes are recommended to existing delegation practices, the streamlined approach will give more responsibility to the regions while maintaining Headquarters oversight. The Team recommends an approach that focuses the Office of Enforcement review on enforcement strategy, severity levels, violations and Enforcement Policy rather than on the actual correspondence. The Team also recommends more staff flexibility in deciding which cases require consultation with the Commission. These changes should provide the necessary oversight to achieve a relatively consistent enforcement program while obtaining the benefits of a streamlined approach. They should also result in decreasing the time to process cases.

Finally, to reinforce the longstanding Commission position that the Enforcement Policy is a statement of general application rather than a binding regulation, the Enforcement Policy should be removed from the Code of Federal Regulations.

**3. *Conclusion***

The Review Team believes that these recommendations should produce an enforcement program with clearer regulatory focus and more predictability. The Review Team expects that these recommendations should increase the public health and safety by better emphasizing the prevention, detection, and correction of violations before events occur with impact on the public.

**Section III.B: Consolidated List of Recommendations****1. Recommendations to the Commission**

The Review Team recommends:

- II.A-1 That the purpose of the enforcement program, as stated in the Enforcement Policy, be modified to read as follows:

The purpose of the NRC enforcement program is to support the NRC's overall safety mission in protecting the public, workers, and the environment. Consistent with that purpose, enforcement actions should be used to create deterrence by:

- ◆ Emphasizing the importance of compliance with requirements, and
- ◆ Encouraging prompt identification and prompt, comprehensive correction of violations.

- II.B-1 That the Enforcement Policy be modified to delete SL V violations, and to provide that formal enforcement action is only taken for violations categorized at or above SL IV. To the extent that minor violations are described in an inspection report, they should be labeled as NCVs. Where a licensee does not take corrective action or repeatedly or willfully commits a minor violation such that a formal response would be needed, the matter should be categorized at least at SL IV.

- II.B-2 That the Enforcement Policy be clarified to permit that a licensee not be required to provide a written response to an NOV where, in the staff's judgment, the information normally included in such a response has already been addressed on the docket.

- II.C-1 That the Enforcement Policy be modified to discontinue conducting enforcement conferences for matters categorized at SL IV.

- II.C-2 That the criteria for holding predecisional enforcement conferences be modified to provide that they be held only when needed to obtain information to make enforcement decisions, such as:

- ◆ a common understanding of the facts, root causes, and missed opportunities to identify the violation sooner,

- ◆ a common understanding of corrective actions, or
- ◆ a common understanding of the significance of the issues and the need for lasting and effective corrective action.

In addition, a conference may be held if the licensee requests it.

- II.C-4 That the Enforcement Policy be modified to state that predecisional enforcement conferences will normally be open to public observation, but not to public participation. The Enforcement Policy should also state under what circumstances predecisional enforcement conferences will not be open to the public (i.e., when involving privacy, safeguards, proprietary, and investigational issues).
- II.C-5 That the Enforcement Policy be modified to include the following purpose statement for conducting open enforcement conferences:
- The purpose of conducting predecisional enforcement conferences in the open is not to maximize public attendance, but rather to provide the public with opportunities to be informed of NRC activities while balancing the need for the NRC staff to exercise its regulatory and safety responsibilities without undue administrative burden.
- II.C-6 That open enforcement conferences be announced using existing notification mechanisms. The practice of issuing press releases for open conferences should be discontinued.
- II.C-7 That the practice of taping open enforcement conferences be discontinued.
- II.C-8 That enforcement conferences be renamed "predecisional enforcement conferences."
- II.D-1 That the practice of issuing CPs for SL IV violations be discontinued. If an SL IV issue becomes significant enough to warrant a CP, then it should be recategorized at SL III.
- II.D-2 That the Enforcement Policy be modified to incorporate the CP assessment strategy proposed in Section II.D.6 of this report.
- II.D-3 That Table 1A of the Enforcement Policy be modified as proposed in Section II.D.7.c of this report.

- II.E-1 That Table 2 be removed from the Enforcement Policy.
- II.F-1 That the NRC normally provide an opportunity for a predecisional enforcement conference with an individual before issuing an order or civil penalty, except where the public health and safety requires immediate action.
- II.F-2 That the Enforcement Policy be clarified to provide that the nine factors used in evaluating individual actions pertain to whether enforcement actions should be issued to an individual as well as to the applicable licensee. In cases of significant wrongdoing, some action normally should be taken against the licensee.
- II.G-1 That the Enforcement Policy be revised to require prior consultation with the Commission for:
- (1) An action affecting a licensee's operation that requires balancing the public health and safety or common defense and security implications of not operating with the potential radiological or other hazards associated with continued operation;
  - (2) Proposals to impose civil penalties for a single violation or problem in amounts greater than 3 times the Severity Level I values shown in Table 1A;
  - (3) Any proposed enforcement action that involves a Severity Level I violation;
  - (4) Any proposed enforcement case involving an Office of Investigations (OI) report where the staff (other than the OI staff) does not arrive at the same conclusions as those in the OI report concerning issues of intent, if the Director of OI concludes that Commission consultation is warranted; and
  - (5) Any action the EDO believes warrants Commission involvement; and
  - (6) Any proposed enforcement action on which the Commission asks to be consulted.
- II.G-2 That OE prepare an annual report summarizing significant actions taken, cases where the exercise of discretion resulted in deviating from standard practice, needed policy changes, audit results, and other enforcement issues that may be of interest to the Commission. This report should also replace the monthly and quarterly timeliness reports provided to the Commission.

II.G-3 That the Enforcement Policy, when next issued, should be removed from the CFR.

**2. *Recommendations to the Staff***

The Review Team recommends:

II.A-2 That the Office of Enforcement review existing staff guidance on enforcement correspondence, to simplify and shorten standard letters to better convey regulatory concerns.

II.B-3 That OE work with the program offices and regions to review the severity level examples in the supplements to ensure that the examples are appropriately focused on safety significance.

II.B-4 That OE work with the program offices and regions to develop additional guidance to describe the threshold for minor violations. The program offices should also work with the regions and OE to develop guidance on when a violation meeting the threshold of an NCV should be documented in an inspection report.

II.B-5 That OE review the *NRC Enforcement Manual* to remove unnecessary formality and effort associated with documenting NCVs.

II.B-6 That the program offices enhance their inspection tracking systems to be able to monitor the number of NOVs issued and the associated number of violations.

II.C-3 That the staff revise existing guidance to provide licensees with the inspection report normally 2 weeks in advance of an enforcement conference.

II.G-4 That the staff revise the process for Headquarters oversight of escalated actions, as described in Section II.G.1.b of this report.

II.G-5 That OE begin publishing significant enforcement actions on an NRC electronic bulletin board, reduce the frequency of publishing NUREG-0940 to semiannual, and evaluate with NMSS more appropriate methods of disseminating significant enforcement findings to materials licensees.

*Appendix A: Review Team Charter*

---

---

- CHARTER -

REVIEW TEAM FOR ASSESSMENT OF  
THE NRC'S ENFORCEMENT PROGRAM

***Purpose:***

To perform an assessment of the NRC's enforcement program to determine whether the defined purposes of the enforcement program are appropriate and whether the NRC's enforcement practices and procedures for issuing enforcement actions are consistent with those purposes and to provide recommendations on any changes the Enforcement Review Team (ERT) believes advisable.

***Team Composition:***

James Lieberman, Director, Office of Enforcement, Team Leader  
William E. Brach, Deputy Director, Division of Industrial &  
Medical Nuclear Safety, NMSS  
James A. Fitzgerald, Acting Director, Office of Investigations  
Luis A. Reyes, Deputy Regional Administrator, Region II  
Roy P. Zimmerman, Associate Director for Projects, NRR

***Legal Advisor:***

Jack R. Goldberg, Deputy Assistant General Counsel for Enforcement

***Resource Support:***

Renée M. Pedersen, OE, is assigned to assist the ERT. The team may acquire resources and support from NRR, NMSS, OE, OI, the regions, and IRM as necessary.

***Background:***

The Commission has developed an enforcement program that seeks to promote and protect the public health and safety by (1) ensuring compliance with the Atomic Energy Act, the Energy Reorganization Act, NRC regulations, and license conditions; (2) obtaining prompt correction of violations and adverse quality conditions that may affect safety; (3) deterring future violations; and (4) encouraging improvement of licensee and vendor performance. These defined purposes and guidance to the NRC staff for implementation of the enforcement program are included in the "General Statement of Policy and Procedures for NRC Enforcement Actions," (Enforcement Policy) that is published as Appendix C to 10 CFR Part 2 of the Commission's requirements. The Commission first published a proposed general statement of policy on enforcement on October 7, 1980 and published a final version of the policy on March 9, 1982. Since that time, the Enforcement Policy has been revised on a number of occasions. The last major revision to the Enforcement Policy was published on February 18, 1992. The last major program review was conducted in 1985 by an Ad Hoc Advisory Committee.



**Team Activities:**

1. Review the evolution of the current enforcement program and policy. This will include an examination of past reviews of the enforcement program and policy such as:
  - the November 16, 1992 OPP Report OPP-92-01, "Assessment of the Reactor Inspection Program,"
  - the November 22, 1985 Report of the Advisory Committee for Review of the Enforcement Policy, and
  - the August 1989 OIG Report OIG87A-20, "Review of NRC's Enforcement Program."
2. Review other selected federal agencies' enforcement programs in considering revisions to the NRC enforcement program.
3. Obtain the views of appropriate staff members including Regional and Program Office managers.
4. Obtain perspectives from the industry, public interest groups, and other members of the public. The ERT will solicit comments through the issuance of a *Federal Register* notice. Any meetings between the ERT and the public to obtain and/or discuss enforcement perspectives will be conducted as public meetings. Any written correspondence between the ERT and the public will be placed in the NRC Public Document Room (PDR).
5. In determining whether the defined purposes of the enforcement program are appropriate and whether the NRC's enforcement practices and procedures for issuing enforcement actions are consistent with those purposes, the ERT is to consider (but not be limited to) the following:
  - i) the balance between providing deterrence and incentives (both positive and negative) for the identification and correction of violations,
  - ii) the appropriateness of NRC sanctions,
  - iii) whether the Commission should seek statutory authority to increase the amount of civil penalties,
  - iv) whether there should be different enforcement policies and practices for different licensees, e.g. small material licensees in contrast to power reactors or large fuel facilities, and
  - v) whether the Commission should establish open enforcement conferences as the normal practice.

**Timing:**

The ERT plans to complete its review and issue its report, including recommendations, by the end of January 1995.

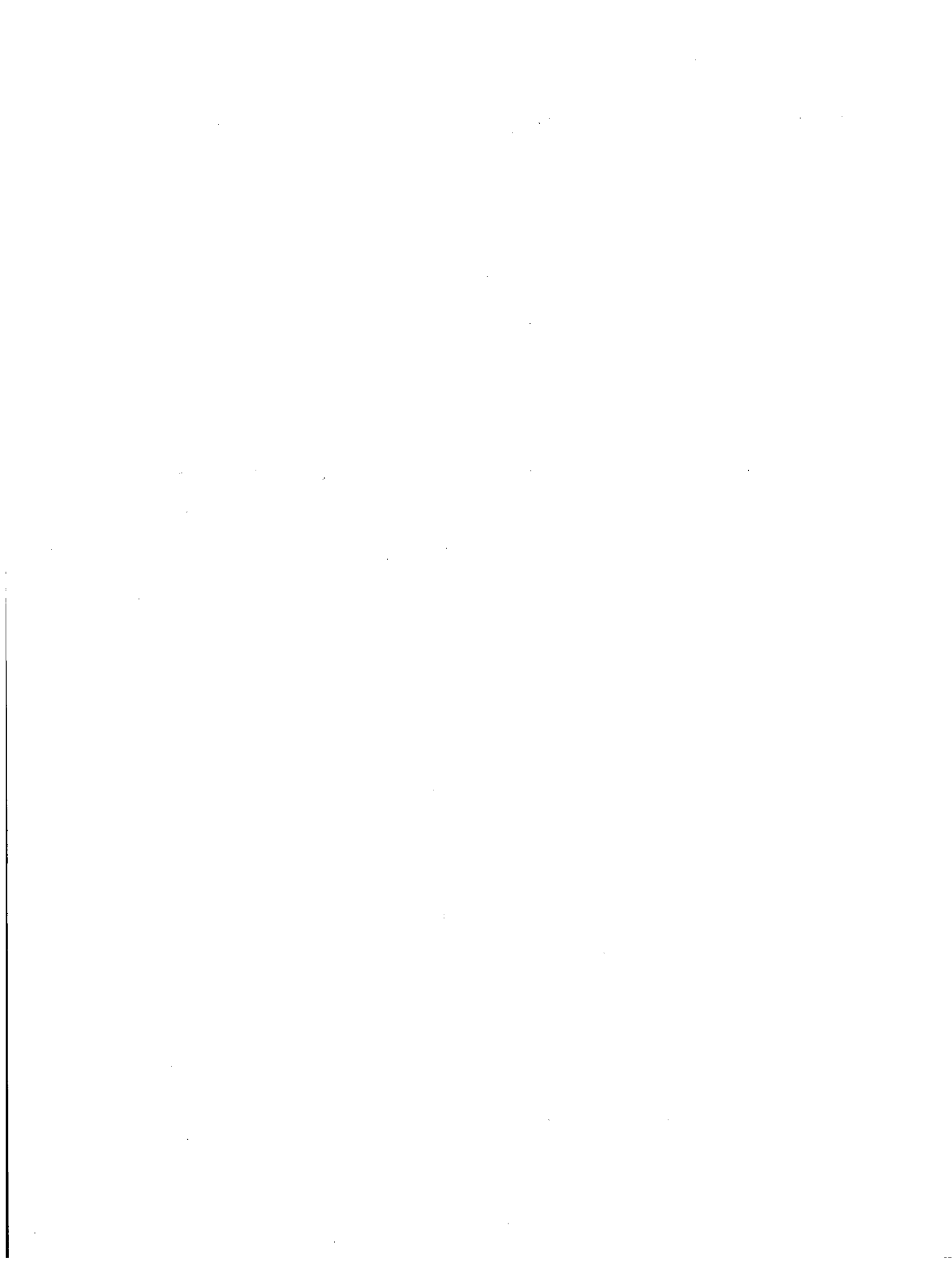

***Appendix B: Federal Register Notices, August and September 1994***

43298

## Proposed Rules

Federal Register

Vol. 59, No. 162

Tuesday, August 23, 1994

This section of the FEDERAL REGISTER contains notices to the public of the proposed issuance of rules and regulations. The purpose of these notices is to give interested persons an opportunity to participate in the rule making prior to the adoption of the final rules.

### NUCLEAR REGULATORY COMMISSION

#### 10 CFR Part 2

#### Reexamination of the NRC Enforcement Policy

AGENCY: Nuclear Regulatory Commission.

ACTION: Proposed rule; Request for public comment.

**SUMMARY:** The Nuclear Regulatory Commission (NRC) is reexamining its enforcement program and requests public comment on whether the scope, purpose, procedures, and methods of its enforcement program are appropriate, and how they may be improved. The NRC is soliciting comments from interested public interest groups, the regulated industry, states, and concerned citizens. Comments from both reactor and materials licensees are requested. This request is intended to assist the NRC in a review of its enforcement program which is being conducted to make recommendations for improvements in the regulatory process.

**DATES:** The comment period expires October 24, 1994. Comments received after this date will be considered if it is practical to do so, but the Commission is able to assure consideration only for comments received on or before this date.

**ADDRESSES:** Submit written comments to: David Meyer, Chief, Rules Review and Directives Branch, Division of Freedom of Information and Publication Services, Office of Administration, Mail Stop: T6D59, U.S. Nuclear Regulatory Commission, Washington, DC 20555. Hand deliver comments to: 11555 Rockville Pike, Rockville, Maryland, between 7:45 am and 4:15 pm, Federal workdays. Copies of comments received may be examined at the NRC Public Document Room, 2120 L Street NW, (Lower Level), Washington, DC. After September 1, 1994, it is expected that comments may also be provided electronically by accessing the NRC

bulletin board system (BBS) that is a subsystem of FedWorld, which is operated by the National Technical Information Service. The NRC BBS can be accessed directly by a toll free number, (800) 303-9672, at modem speeds up to 9600 Baud with communication parameters set at 8 data bits, no parity, 1 stop bit, full duplex, and ANSI terminal emulation. Select the "Subsystems/Databases" option from the "NRC Main Menu" and then the "Enforcement Program" option. The "Help/Information Center" from the "Enforcement Program Menu" provides selections on "Request for Comments on the Enforcement Policy" and "How to Leave an Official Comment." The NRC BBS can also be accessed from the FedWorld "Subsystems/Databases" menu, which could facilitate user access using the Internet. FedWorld's access via Internet is Telnet access: fedworld.gov (192.239.92.3); FTP site access: ftp.fedworld.gov (192.239.92.205), and World Wide Web (Home Page): www.fedworld.gov (this is the URL).

**FOR FURTHER INFORMATION CONTACT:** James Lieberman, Director, Office of Enforcement, U.S. Nuclear Regulatory Commission, Washington, DC 20555, (301) 504-2741. Questions on the NRC BBS may be directed to Tom Dunning at (301) 504-1189.

**SUPPLEMENTARY INFORMATION:** On May 13, 1994, the Executive Director for Operations directed a Review team composed of Senior NRC managers to reexamine the NRC enforcement program. The Review Team is chaired by James Lieberman, Director, Office of Enforcement, and includes James Fitzgerald, Acting Director, Office of Investigations, Roy Zimmerman, Associate Director for Projects, Office of Nuclear Reactor Regulations, William Brach, Deputy Division Director, Division of Industrial and Medical Nuclear Safety, Office of Nuclear Materials Safety and Safeguards, Luis Reyes, Deputy Administrator Region II, and Jack Goldberg, Deputy Assistant General Counsel for Enforcement.

The purpose of this review effort is to (i) perform an assessment of the NRC's enforcement program to determine whether the defined purposes of the enforcement program are appropriate, (ii) determine whether the NRC's enforcement practices and procedures for issuing enforcement actions are

consistent with those purposes, and (iii) provide recommendations on any changes the Review Team believes advisable. It is expected that the Review Team will complete its review and issue its report, including recommendations, by the end of January 1995.

The NRC's enforcement program is guided by the Commission's "General Statement of Policy and Procedure for NRC Enforcement Actions" (Enforcement Policy). The Enforcement Policy is published in the Code of Federal Regulations at 10 CFR part 2, appendix C to provide widespread dissemination of the Commission's Enforcement Policy. However, it is a policy statement and not a regulation. The Enforcement Policy notes that the Commission, as appropriate under the circumstance of a particular case, can deviate from it.

The Commission's Enforcement Policy was first published in 1980 as an interim policy. 45 FR 66754 (October 7, 1980). On March 9, 1982 (47 FR 9987), the Commission published a final version of the policy. Since that time, the Enforcement Policy has been modified on a number of occasions to address changing requirements and additional experience. The current Enforcement Policy is reflected in the 1994 Code of Federal Regulations as supplemented by a July 15, 1994 (59 FR 36026), modification to provide additional severity level examples.

Since the Enforcement Policy was first promulgated, the purpose and the four objectives for the NRC enforcement program have remained essentially unchanged. Section I of the Enforcement Policy states that:

The purpose of the NRC enforcement program is to promote and protect the radiological health and safety of the public, including employees' health and safety, the common defense and security, and the environment by (the following four objectives):

- Ensuring compliance with NRC regulations and license conditions;
- Obtaining prompt correction of violations and adverse quality conditions which may affect safety;
- Deterring future violations and occurrences of conditions adverse to quality; and
- Encouraging improvement of licensee and vendor performance, and by example, that of industry, including the prompt identification and reporting of potential safety problems.

In summary, the Enforcement Policy provides for a graduated set of sanctions based on the severity of the violations. Normally, each violation or grouping of violations is categorized into one of five severity levels based on the relative importance of the violation, including both the technical significance, i.e. the actual and potential consequences, and the regulatory significance including any willfulness associated with the violation. Formal sanctions include Notices of Violations, civil penalties, and orders. In determining the particular sanction to be used, consideration is given to (i) the severity level of the violation, including its duration, (ii) the licensee's response to the violation, including whether the licensee identified the violation and corrected it, and (iii) the licensee's past performance, including whether the violation was a recurring one, the licensee's compliance history and general performance, and whether there were prior opportunities to discover, correct, or avoid the violation. The Enforcement Policy provides for the ability to exercise discretion to increase or reduce sanctions (including dispositioning certain violations as non-cited violations) to provide appropriate regulatory messages to encourage improved performance. Enforcement actions involving orders or violations at Severity Level I, II, or III are considered more significant and are referred to as escalated actions. In addition to formal enforcement sanctions, NRC also uses administrative actions such as Demands for Information, Confirmatory Action Letters, and Letters of Reprimand.

In accordance with its charter, the Review Team, is to consider, but not be limited to, the following issues in conducting its assessment of the enforcement program:

(i) The balance between providing deterrence and incentive (both positive and negative) for the identification and correction of violations,

(ii) The appropriateness of NRC sanctions,

(iii) Whether the Commission should seek statutory authority to increase the amount of civil penalties,<sup>1</sup>

<sup>1</sup> In 1993, the Commission conducted a reassessment of the NRC's program for protecting allegers against retaliation. The Review Team which performed that reassessment recommended, among other things, that the NRC should seek an amendment to section 234 of the Atomic Energy Act of 1954 to increase the current maximum civil penalty of \$100,000 to \$500,000 per day per violation to be normally used for willful violations including those involving discrimination. Recommendation II-D-3, "Reassessment of the NRC's Program for Protecting Allegers Against Retaliation," NUREG-1499 (January 1994). The Commission did not act on this recommendation.

(iv) Whether there should be different enforcement policies and practices for material licensees in contrast to power reactors or large fuel facilities, and

(v) Whether the Commission should establish open enforcement conferences as the normal practice.<sup>2</sup>

Public comments are sought on these issues to assist the Review Team in its reassessment. In addition to general comments on the above issues, the Review Team seeks comments on a number of specific issues.

Comments are sought from both reactor and material licensees, vendors, other persons who are subject to NRC enforcement jurisdiction, state and local governments, and other members of the public who may have an interest in NRC enforcement actions. Although the Review Team is interested in as many comments as possible, commenters are not obligated to and need not address every issue.

In providing comments, please key comments to the numbering system used to identify the specific issues by providing the issue number before the particular comment (e.g., Response to A.3). General or anecdotal comments (such as a general comment to the effect that some enforcement conferences have not been effective or that some enforcement cases have been inconsistent with the Enforcement Policy) will not be particularly useful. Rather comments should be as specific as possible and should reference specific cases, as appropriate, so that the Review Team can understand and evaluate the comment. Responses which call for a "yes" or "no" answer should be accompanied with an explanation as to why the commenter agrees or disagrees with the issue. When the term licensee is used in the issues listed below, it refers, as applicable, to licensees, vendors, and other persons subject to NRC enforcement actions.

Comments may be provided in hard copy or through the NRC electronic bulletin board (BBS). Instructions for accessing the NRC BBS are provided in the ADDRESSES section above.

Following evaluation of the comments, the Review Team may hold

but instead, the Commission approved a staff proposal to defer action on the recommendation pending a review of the NRC Enforcement Program.

<sup>2</sup> In 1992, the NRC established a two-year trial program for conducting enforcement conferences open to attendance by members of the public (57 FR 30762, July 10, 1992). This trial program was to end July 11, 1994 upon which date comments were due on whether NRC should routinely conduct open enforcement conferences. However, in light of the reexamination of the enforcement program, the trial program was extended pending the outcome of the enforcement program review (50 FR 38793, July 18, 1994).

a public meeting in the Washington, D.C. area for the purpose of clarifying comments. In that regard, commenters are requested to indicate whether they would desire to participate in a public meeting. It is expected that the Review Team would invite specific commenters to participate on panels of commenters with similar views. If a meeting is to be held, it will be announced in the Federal Register and on the NRC BBS.

Comments are requested on the following specific issues:

#### A. Purpose and Objectives of the NRC Enforcement Program

1. Is the purpose of the enforcement program stated above the proper area of focus for the NRC enforcement program? If not, why not and what should the purpose be?

2. Are the four objectives of the NRC enforcement program stated above (i.e., ensuring compliance, obtaining corrective action, deterring future violations, and encouraging improved performance of other licensees and vendors) appropriate? If not, why not and what should the objectives be?

3. Does the enforcement program as implemented achieve the stated purpose and objectives? Explain why or why not.

(a) Are enforcement sanctions effective in obtaining comprehensive and lasting corrective action, i.e., does the time and effort spent in developing responses to enforcement actions result in a more thought out approach for corrective action and implementation of that action than would otherwise occur?

(b) Do some types of sanctions result in more extensive, comprehensive, or lasting corrective action than others?

(i) If so, which types of sanctions are more effective than others, i.e., (a)

Notices of Violation at Severity Level V, at Severity Level IV with and without a civil penalty, at Severity Level III with and without a civil penalty, at Severity Level II with and without a civil penalty, and at Severity Level I with and without a civil penalty, and (b) orders?

(ii) If so, why? For example, do some sanctions get more management attention than others, i.e., do all senior licensee officials, such as the Vice Presidents, President, Chief Executive Officer or Board of Directors, get copies of every sanction including non-cited violations, or do senior officials only get copies of certain types of sanctions such as civil penalties or orders, or for that matter do they get copies at any time?

(iii) If not, what changes could be made to improve corrective action?

(c) Has the NRC's past use of sanctions created deterrence, i.e., does the threat of sanctions contribute to the desire to maintain compliance?

43300 Federal Register / Vol. 59, No. 162 / Tuesday, August 23, 1994 / Proposed Rules

(i) If not, what changes could be made to provide more deterrence?

(ii) Commenters are requested to address the deterrence value of each type of sanction: (a) Notices of Violation at Severity Level V, at Severity Level IV with and without a civil penalty, at Severity Level III with and without a civil penalty, at Severity Level II with and without a civil penalty, and at Severity Level I with and without a civil penalty, and (b) orders.

(iii) To what extent does the issuance of press releases contribute to the deterrence?

(iv) Should press releases be issued for Notices of Violation, Confirmatory Action Letters, Demands for Information as well as civil penalties and orders? If not, why not?

(d) Do NRC sanctions against particular licensees result in improving the general performance of the regulated industry by encouraging other licensees to take actions to prevent or identify and correct similar violations at their facilities after learning of the violations and sanctions imposed on other licensees?

(i) Licensee commenters should address whether they are normally aware of enforcement actions issued against other licensees at the level of (1) non-escalated Notices of Violations, (2) escalated Notices of Violations without civil penalties, (3) civil penalties, and (4) orders.

(ii) If commenters are aware of enforcement actions issued against other licensees, how do they become aware of them (e.g. NUREG 0940, "Enforcement Actions: Significant Actions Resolved," NRC Information Notices, NMSS Newsletters, press releases, law firm news letters, industry newsletters such as Inside NRC or Nuclonics Weekly, NRC inspectors, Federal Register, or other sources)? Should NRC consider better ways to provide licensees and vendors with information about NRC enforcement actions such as use of an electronic bulletin board or an enforcement newsletter?

(iii) If commenters are aware of enforcement actions issued against other licensees, is the information from those actions used to improve performance? How is it used to achieve better performance (e.g., discussed during staff meetings, incorporated into training, or made the subject of required reading)?

4. Agency-wide (i.e., from region to region) consistency and predictability in the nature and type of sanctions have been important considerations in developing enforcement sanctions. As a result, the Enforcement Policy has become substantially more detailed since the initial policy was published in

1980. While flexibility is provided, deviations from the norms of the Enforcement Policy require approval or consultation with senior NRC officials, and in some cases, the Commissioners.

(a) If the enforcement program as implemented does not provide an appropriate degree of consistency and predictability, what are the problem areas and what changes could be made for improvement in this area?

(b) Should the Enforcement Policy be simplified and allow for more staff judgement and issuance of enforcement actions with less management review? If so, provide examples where changes could be made. If so, why and how?

5. When developing enforcement sanctions, how should the NRC attempt to balance punishment and incentives? [Note: this question addresses issuance of sanctions in general, questions on issuance of civil penalties are addressed in section E. of this notice.] Comments are requested on whether the remedial value of enforcement would be improved by:

(a) Basing sanctions solely on the occurrence of the violation and its technical and regulatory significance to maximize the incentive to discourage violations from occurring. Under this approach, in formulating a sanction, NRC would consider whether the violation occurred, but would not consider whether the licensee identified the violation and corrected it and would not consider the licensee's past performance, i.e., some or all sanctions would be issued somewhat like a traffic ticket. For example, an overexposure would have a fixed penalty for a given type of licensee. Commenters who favor this approach should address the question of whether this approach would tend to discourage licensees and employees from identifying violations that are not self disclosing and broadly correcting violations as those actions would not affect the sanction.

(b) Basing sanctions solely on the licensee's response to the violation. Under this approach, NRC would not issue a sanction if the licensee promptly identified, reported it if required, and promptly and comprehensively corrected the violation; that is the NRC would not consider past performance, duration, multiple occurrences, prior opportunities to identify and correct the violation earlier if the licensee identified and corrected the violation prior to NRC identifying the violation, the NRC scheduling an announced inspection in the area that encompasses the violation, or an event that disclosed the violation. Commenters who favor this approach should address the question of whether this approach

would reduce the incentives to identify violations, including responding to opportunities to identify potential violations, or assuring lasting corrective action because the licensee may take the risk that NRC might not identify the violation as a result of the limited, audit nature of the NRC inspection program. How should reporting of a violation be considered? For example, should full mitigation be allowed if a violation was not reported?

(c) Basing sanctions on a combination of approaches (a) and (b) above, similar to the current NRC approach. Commenters who favor this approach should address which factors should be included in establishing sanctions and the weight that might be appropriate for each factor.

6. The Enforcement Policy is intended to provide regulatory messages to improve performance such as encouraging identification of violations, being responsive to information that may suggest the need to take action to determine the existence of a violation, taking prompt, comprehensive and lasting corrective action, and addressing performance problems.

(a) Does the enforcement correspondence that transmits the enforcement actions adequately convey the above messages?

(b) Does the enforcement correspondence that transmits the enforcement actions adequately convey the significance the NRC places on the violations, the areas where improvement in performance are needed, and the reasons for the sanctions?

(c) Is the enforcement correspondence understandable? Should it be simplified? If so, how?

7. Should there be different enforcement policies and procedures (e.g., correspondence, enforcement conferences, inspection documentation, civil penalty assessment factors) for large licensees, such as power reactors and major fuel facilities, and for smaller licensees? If so, how should the policies and procedures differ?

#### B. Severity Levels of Violations

Violations are normally categorized in terms of five levels of severity to show their relative importance within a particular activity area such as "reactor operations" or "health physics." The level of severity assigned is intended to be based on the violation's actual or potential safety consequence and regulatory significance within the selected activity area. Specific examples of severity levels for particular violations are given in the Enforcement Policy supplements to improve

consistency and enhance the ability to apply the policy.

1. Should the NRC continue to use the existing severity levels to categorize regulatory and safety significance of violations? If not, why not and how should the Enforcement Policy be changed?

2. Is there a benefit to have both a Severity Level IV and V? Should severity levels be used at all if violations are not associated with a civil penalty?

3. Recognizing that not all violations are of equal significance, are there sufficient examples to categorize the range of significance of violations?

(a) Do the existing examples appropriately reflect significance? If not, why not?

(b) If the existing examples are not sufficient, what other examples should be included?

(c) Should the examples be revised to be more general? More specific?

(d) Is sufficient flexibility provided to consider willfulness and other circumstances? What circumstances not now considered should be considered, if any, in establishing a severity level?

#### C. Enforcement Conferences

The Enforcement Policy provides that when the NRC learns of a potential violation for which escalated enforcement action may be warranted, the NRC normally provides the licensee an opportunity for an enforcement conference prior to taking enforcement action. A conference may also be held for a Severity Level IV violation if increased management attention is warranted. The purpose of the conference is to discuss the potential violations, their significance, the reason for their occurrences including the root causes, and the licensee's corrective actions. It provides NRC management an opportunity to emphasize, directly with senior licensee management, the significance of the violations and the need for effective lasting corrective action. Also, the NRC uses the conference to determine whether there were any aggravating or mitigating circumstances, and to obtain any other information, including whether the licensee questions the findings of the inspection, which may assist in determining the appropriate enforcement action.

Enforcement conferences are not routinely open to the public. (However, a trial program to open about 25 percent of the conferences to the public is currently underway. See footnote 2)

1. Do enforcement conferences serve the purposes stated above? If not, how can they be improved?

2. What are the benefits and weaknesses of conducting enforcement conferences?

3. In deciding whether to hold a conference, should the NRC consider whether the licensee desires to attend a conference?

4. Is the current criteria used to hold a conference appropriate? If not, when should conferences be held?

5. Recognizing that apparent violations may be reconsidered following an enforcement conference, should NRC continue the practice of issuing inspection reports that address the apparent violations prior to an enforcement conference?

6. Enforcement conferences are normally held in regional offices. Should this continue, or should they be held closer to the facility of the licensee?

7. As to open enforcement conferences:

(a) Have open enforcement conferences affected NRC performance during the conference? If so, how?

(b) Have open enforcement conferences impacted the licensee's participation in the conference? If so, how?

(c) Have open conferences impacted the licensee's cost of participating at conferences? If so, how? If more preparation is required, how substantial is that preparation and why should the presence of public attendance impact the licensee's presentation?

(d) Has the public benefited from the ability to observe enforcement conferences?

(e) Should all enforcement conferences be transcribed with the transcript subsequently made public? For those who oppose open conferences, would that be a viable alternative to open enforcement conferences?

(f) The NRC staff in Rockville, Maryland frequently participates in closed enforcement conferences held in the region by telephone.

(i) Is that appropriate for open conferences?

(ii) Should the public be allowed to listen by telephone to open conferences?

(g) Should open enforcement conferences be made a permanent part of the enforcement program?

8. Are there circumstances where a Demand for Information may be an appropriate substitution for an enforcement conference? If so, what circumstances should be considered?

#### D. Notices of Violations

The policy of the Commission has been to formalize the occurrence of a violation by issuance of a Notice of Violation and by requiring documented corrective action.

1. There are circumstances provided in the Enforcement Policy for not issuing a formal notice of violation to provide incentives for identification and corrective action for violations at Severity Level IV, as well as to save both NRC and licensee resources for violations at Severity Level V. In general where the licensee has identified a non-recurring violation at Severity Level IV and taken appropriate corrective action, the inspection finding is documented in the inspection report and closed out as a "non-cited violation," with no written response required.

(a) Should the circumstances for use of non-cited violations be changed to cover more situations or fewer (including different severity levels)? If so, explain.

(b) Does the use of non-cited violations contribute to providing an incentive for identifying and correcting violations or does it have the same negative impact as a cited violation in a Notice of Violation?

(c) Should non-cited violations be treated any differently from a cited violation when considering compliance history in the deliberations on the appropriate regulatory response to a subsequent violation? If so, explain.

(d) Should NRC continue to use non-cited violations?

(e) If non-cited violations should not be used in the future, how should the NRC disposition findings in an inspection report that provides sufficient detail to demonstrate that a violation occurred? How should NRC track these findings and what should they be called?

2. Is there any purpose to issuing Notices of Violations at Severity Level V? Should all such violations be treated as non-cited violations?

3. Should all Notices of Violations require a written response? If not, what should the documentation requirements be for corrective action? What access rights should be given to the public to review the documentation?

4. The materials program utilizes NRC Form 591, "Safety Inspections," which an inspector may use to document certain violations and after the licensee signs the form stating that corrective action will be taken within 30 days, serves as a Notice of Violation. Form 591 is intended to be issued by the inspector directly to the licensee without further agency review at the conclusion of the inspection.

(a) Should this process be expanded to cover fuel cycle and reactor licensees?

(b) Should this process be expanded to cover other enforcement sanctions?

43302 Federal Register / Vol. 59, No. 162 / Tuesday, August 23, 1994 / Proposed Rules

**E. Civil Penalties**

A civil penalty is a monetary penalty that may be imposed for certain violations. Civil penalties are intended to emphasize the need for lasting remedial action, and to deter future violations both by the licensed party and by other licensees conducting similar activities.

The base civil penalty amounts have not been changed since the early 1980's. To maintain a constant dollar amount for civil penalties, adjustment for inflation would increase the current amounts by more than 60 percent. For smaller licensees, a civil penalty may be a deterrent because of the financial impact; for power reactor licensees, the current civil penalty amounts are of little financial impact, but may have a deterrent effect through the adverse publicity that attends the issuance of a civil penalty.

1. Should civil penalties continue to be part of the NRC regulatory process? If not, why not? How and when should they be used?

2. Have civil penalties been effective in improving compliance and providing deterrence? If so, why? If not, why not?

3. The Review Team on Reassessment of the NRC's Program for Protecting Allegers Against Retaliation concluded that higher civil penalties are appropriate and recommended a statutory amount of \$500,000. The legislative history for section 234 of the Atomic Energy Act does not provide a specific basis for the current statutory amount of \$100,000. The recommendation of that Review Team was based on the average cost of a day of replacement power for a power reactor. The recommended increase was intended to provide a more financially relevant penalty and provide for a greater spread of penalty amounts among the severity levels. (See, NUREG 1499 at page II.D-5-6)

(a) Given that significant violations continue to be identified, and that civil penalties are intended to have a punitive aspect, would higher civil penalties provide a greater incentive for compliance for the larger licensees regulated by the Commission?

(b) Should the statutory amount of civil penalties be increased? If so, to what extent? If not, why not?

(c) Since the civil penalty amount in Section 234 of the Atomic Energy Act was last amended in 1980, there has been considerable inflation. Should the base civil penalties be indexed for inflation?

(d) Should the civil penalty amount take into consideration the costs associated with an enforcement action

including the cost of the investigation and processing the action?

4. Should the amount of the penalty be normally based solely on the existence of the violation similar to a traffic ticket? If so, why? If not, why not?

(a) If not, are there some violations such as overexposures to workers, releases of radioactive material, exposures to members of the public, failure to use survey instruments by radiographers, etc. where civil penalties should be assessed without regard to adjustment factors? If not, why not?

(b) Does it matter whether a penalty is increased or decreased from the base amount, or is the existence of a penalty the controlling factor?

5. Should the penalty consider contributing factors, such as the root cause of or the licensee's response to the violation? If so, why? If not, why not?

6. The current adjustment factors are designed to encourage good performance (e.g., prompt identification, prompt and comprehensive corrective action, and evidence of past lasting corrective action) and deter poor performance (e.g., lack of identification and prompt or comprehensive corrective action, not being responsive to opportunities to identify violations, and not taking lasting corrective action). The NRC expends considerable effort to adjust civil penalties to provide an appropriate regulatory message.

(a) Should the current civil penalty adjustment factors continue to be used? If not, why not and which factors should be deleted or what factors should be added?

(b) Do the current adjustment factors provide the intended incentives or deterrence? If not, please explain.

7. Comments are requested on the use of the specific factors.

(a) Should there be any mitigation for self-disclosing events where the violation is relatively obvious, i.e., given the event, the licensee really has no choice but to pursue it to determine the cause? If not, why not? If so, why?

(b) Should mitigation be allowed for corrective action, if the individuals responsible for the violations, assuming adequate resources, training, procedures, and supervision, have not been appropriately disciplined? How extensive should corrective action be to permit mitigation?

(c) Since enforcement should be designed to influence performance, should past poor performance be considered and cause penalties to be increased if current performance is good, i.e., the licensee identifies and corrects the particular violation assuming recent performance (e.g., six

months) has been good and there has not been a failure to be responsive to opportunities of prior notice? Similarly, should past good performance be considered and cause penalties to be lowered where current performance is not good, i.e. the licensee does not identify and corrects the violations?

(d) The Atomic Energy Act provides that each day a violation continues shall be considered a separate violation for assessing a civil penalty. The longer a violation exists the likelihood of a consequence increases. Should duration be routinely considered if a civil penalty would otherwise be assessed? If not, why not and how should duration be factored into the amount of the penalty?

(e) Should prompt, comprehensive corrective action by the licensee be sufficient to warrant full mitigation of the civil penalty, regardless of the other factors such as prior performance, duration, prior opportunities, and lack of identification or reporting?

(f) Should there be civil penalties if the licensee identifies and promptly and comprehensively corrects a violation? If so, how should factors such as repetitive violations, past poor performance, prior opportunities to have identified the violation earlier, multiple examples and duration be considered?

(g) Reporting is not currently considered as an assessment factor and reporting failures are considered for enforcement separate and apart from the matter not reported. How should reporting issues be considered?

(i) Should there be full mitigation if a licensee identifies a violation associated with a reportable matter, when the report is not properly made?

(ii) Should reporting a violation be considered a separate mitigating factor? If so, should mitigation be allowed where the matter reported was required to be reported since not to do so would be a separate violation subject to a separate sanction?

(iii) Should there be a separate sanction for reporting failures apart from the violation not reported?

(h) In applying the factors of past performance and prior opportunities to identify violations, over what time period should these factors be considered (e.g., events that occurred two years prior to the violation for which the current sanction is being considered)?

(i) Is it appropriate to consider the same facts in determining the existence of a violation, its severity level, and in the application of the assessment factors (e.g., in a corrective action violation escalating a penalty for opportunities to correct a matter earlier and considering the delay as added significance in



establishing the severity level)? If not, why not?

8. The Enforcement Policy provides some flexibility in applying the adjustment factors but it does provide specified percentages to limit the application of the factors.

(a) Should the Enforcement Policy be changed to permit consideration of factors without providing specified percentages that should be used for the assessment? If not, why not?

(b) If so, should there be any outer limit other than the statutory maximum per violation?

(c) The deletion of percentages will permit greater judgement and flexibility to arrive at an appropriate penalty. Will this create a concern for consistency and predictability?

9. Regional Administrators have been delegated the authority to issue civil penalties for certain materials cases without review by the Office of Nuclear Materials, Safety and Safeguards, Office of Enforcement, or the Office of General Counsel.

(a) Should delegation be similarly considered for certain reactor cases? If so, what cases warrant such delegation and why? If delegation is not appropriate, why not?

(b) Are there some violations for which the inspector or section chief should be allowed to issue proposed civil penalties without further agency review? (See question D.4)

10. The Enforcement Policy in Table I.A establishes base civil penalties for different types of licensees. In developing the table it was intended that generally, operations involving greater nuclear inventories and greater potential consequences to the public and licensee employees would receive higher civil penalties and that the amounts, as a secondary factor, would reflect an ability to pay the penalty. Table I.A does not reflect that for a given type of licensee there can be a wide range in sizes, abilities to pay, and potential hazards (e.g., large broad base hospitals in comparison to small rural community hospitals, large research reactors in comparison to very small reactors, or nation wide radiographer firms in comparison to one person radiographer firms).

(a) Should Table I.A reflect different sizes of licensees and different hazards for a given type of licensee? If so, how should this be considered and reflected in the Enforcement Policy?

(b) Are the categories of licensees listed in Table I.A appropriate? If not, what changes should be made and why?

(c) Are the base civil penalties amounts in Table I.A of the Enforcement Policy appropriate for the different

types of licensees? If not, what changes should be made and why?

(d) Are the percentages listed in Table I.B appropriate for the different severity levels (e.g., 80 percent of the base civil penalty for a Severity Level II violation)? If not, what changes should be made and why?

#### F. Orders and Confirmatory Action Letters

An order is a written NRC directive to modify, suspend, or revoke a license, or cease and desist from a practice or activity. A Confirmatory Action Letter is a document that reflects commitments made by a licensee which may in some cases reflect significant obligations.

Unlike an order, it does not create legal obligations other than a reporting requirement if an obligation is not met.

1. Should orders be used to a greater or lesser extent than at present?

2. Should Confirmatory Action Letters be used to a greater or lesser extent than at present?

3. Under what circumstances should a Confirmatory Action Letter be used as a substitute for an order?

4. Are licensees actions in response to Confirmatory Action Letters different from orders? Do licensees treat them differently?

#### G. Exercise of Discretion

The Enforcement Policy in Section VII.A and B provides guidance on when to exercise discretion, and either escalate or mitigate enforcement sanctions, to ensure that the resulting enforcement action appropriately reflects the level of NRC concern, and conveys the appropriate regulatory message to the licensee. [Note, the enforcement review is not addressing section VII.C. of the Enforcement Policy entitled, "Exercise of Discretion for an Operating Reactor" that addresses "Notices of Enforcement Discretion."]

1. Is the guidance provided for exercise of discretion adequate?

2. Should there be additional examples where discretion should be exercised? For example, should facilities that are recognized by the NRC to be poor performers (sometimes referred to as plants on the "watch list" or "problem plant list") continue to be subject to civil penalties during the period of time it takes to improve their performance which normally takes some time to achieve? Should such discretion be exercised even if an average performer with the same violations would receive a civil penalty? Should the response be dependent on whether the plant is shut down or operating? Should the response be dependent on

whether the licensee or the NRC identifies the violation?

#### H. Timeliness of Enforcement Actions

The NRC attempts to issue routine escalated enforcement actions within eight weeks of identification of the potential enforcement issue. An enforcement conference is typically held within four weeks of completion of an inspection.

1. Are these timeliness guidelines for issuance of escalated enforcement actions appropriate?

2. Enforcement conferences are usually scheduled at the convenience of the NRC in the interest of timely enforcement actions. In scheduling enforcement conferences, should NRC schedule them at the mutual convenience of both the NRC and licensee even if it delays the enforcement action, assuming that the delays are not unreasonable?

3. Some enforcement cases take considerably longer than the eight week goal noted above. Has such delay substantially impacted licensees? Is such delay a significant concern? Explain.

4. If the time to process an escalated enforcement action should be reduced, should it be done at the expense of omitting review by the Office of General Counsel, Office of Enforcement, or the appropriate program office?

#### I. Violations Involving Willfulness and Actions Against Persons for Wrongdoing

The NRC's Enforcement Policy identifies willful violations to be of particular concern, and provides for escalation of the severity level of a violation based on willfulness.

1. Does the Enforcement Policy appropriately reflect the significance of willful violations? If not, how should the Policy be changed to better reflect the significance of willful violations?

2. Is sufficient guidance provided for developing sanctions against licensees for willful violations? If not what additional guidance or criteria would be appropriate?

3. Is sufficient guidance provided for developing consistent sanctions against individuals for wrongdoing? If not, what additional guidance or criteria would be appropriate?

4. NRC focuses its enforcement actions on licensees. Normally the NRC when it issues sanctions to licensees' employees, contractors or other agents, also issues sanctions to licensees. Should the NRC issue enforcement actions to licensees when sanctions are also issued to their employees, contractors or other agents? If not, why

---

43304 Federal Register / Vol. 59, No. 162 / Tuesday, August 23, 1994 / Proposed Rules

---

not, and under what circumstances should action not be taken against licensees for the actions of others?

5. Should orders be used more frequently against individuals who violate the rule on deliberate misconduct (e.g., 10 CFR 30.10, 40.10, and 50.5)? Does the potential for the use of such orders increase accountability by employees and contractors? Do employees and contractors appreciate that they may be subject to direct action by the NRC?

8. Should the NRC use civil penalties against individual wrongdoers who violate regulations such as 10 CFR 30.10 and 10 CFR 50.5 in lieu of orders which impact the employees' livelihood?

7. A Letter of Reprimand is used to notify an individual of a violation when a formal sanction is not warranted. Should a Letter of Reprimand be used rather than a more formal action such as a Notice of Violation or an order where the individual has willfully violated a requirement? If so, under what circumstances? For example, should it be used in cases where a relatively low level employee has been fired as a result of the violation and the employee appears to be candid and remorseful.

8. If a criminal sanction is issued against an employee or agent of a licensee who caused the violation, should civil sanctions be issued against the licensee who is licensed by the NRC for the activity?

9. The Enforcement Policy also states that civil penalties are considered for all willful violations. However, to encourage licensees to identify willful violations and to take strong remedial actions to demonstrate the seriousness of such violations to other employees and contractors thereby creating a deterrent effect, discretion may be exercised for certain willful violations at Severity Level IV or V. Is this consistent with the seriousness of willful violations and should this policy be continued? Should it be expanded to other severity levels?

#### J. Additional Comments

In addition to the above specific issues, commenters are invited to provide any other views on the NRC enforcement program which may assist the NRC in improving the effectiveness of NRC enforcement efforts.

Dated at Rockville, Maryland, this 16th day of August 1994.

For the Nuclear Regulatory Commission,

James Lieberman,

Director, Office of Enforcement.

[FR Doc. 94-20618 Filed 8-22-94; 8:45 am]

BILLING CODE 7890-01-P

---

Federal Register / Vol. 59, No. 188 / Tuesday, September 27, 1994 / Proposed Rules 49215

---

---

**NUCLEAR REGULATORY  
COMMISSION**

10 CFR Part 2

**Reexamination of the NRC  
Enforcement Policy**

**AGENCY:** Nuclear Regulatory  
Commission.

**ACTION:** Request for public comment.

**SUMMARY:** The Nuclear Regulatory Commission (NRC) is expanding its reexamination of its enforcement program to include the issue of Notices of Enforcement Discretion for operating power reactors and requests public comment on issues associated with that matter. The NRC is soliciting comments from interested public interest groups, the regulated industry, states, and concerned citizens. This request is intended to assist the NRC in a review of its enforcement program which is being conducted to make recommendations for improvements in the regulatory process.

**DATES:** The comment period expires October 24, 1994. Comments received after this date will be considered if it is practical to do so, but the Commission is able to assure consideration only for comments received on or before this date.

**ADDRESSES:** Submit written comments to: David Meyer, Chief, Rules Review and Directives Branch, Division of Freedom of Information and Publication Services, Office of Administration, Mail Stop: T8D58, U.S. Nuclear Regulatory Commission, Washington, DC 20555. Hand deliver comments to: 11555 Rockville Pike, Rockville, Maryland, between 7:45 am and 4:15 pm, Federal workdays. Copies of comments received may be examined at the NRC Public Document Room, 2120 L Street, NW (Lower Level), Washington, DC.

Comments may also be provided electronically by accessing the NRC bulletin board system (BBS) that is a subsystem of FedWorld, which is

48216 Federal Register / Vol. 59, No. 186 / Tuesday, September 27, 1994 / Proposed Rules

operated by the National Technical Information Service. The NRC BBS can be accessed directly by a toll free number, (800) 303-9672, at modem speeds up to 9600 Baud with communication parameters set at 8 data bits, no parity, 1 stop bit, full duplex, and ANSI terminal emulation. Select the "Subsystems/Databases" option from the "NRC Main Menu" and then the "Enforcement Program" option. The "Help/Information Center" from the "Enforcement Program Menu" provides selections on "Request for Comments on the Enforcement Policy" and "How to Leave an Official Comment." The NRC BBS can also be accessed from the FedWorld "Subsystems/Databases" menu, which would facilitate user access using the Internet. FedWorld's access via Internet is Telnet access: fedworld.gov (192.239.92.3); FTP site access: ftp.fedworld.gov (192.239.92.205), and World Wide Web (Home Page): www.fedworld.gov (this is the URL).

**FOR FURTHER INFORMATION CONTACT:** James Lieberman, Director, Office of Enforcement, U.S. Nuclear Regulatory Commission, Washington, DC 20555, (301) 504-2741. Questions on the NRC BBS may be directed to Tom Dunning at (301) 504-1189.

**SUPPLEMENTARY INFORMATION:** On August 23, 1994 (59 FR 43298)<sup>1</sup>, the Review Team for the Reexamination of the NRC Enforcement Program issued a Federal Register notice announcing a reexamination of the NRC enforcement program and requesting comments on the enforcement program. The comment period will close for that notice on October 24, 1994. Comments for this notice should also be submitted by October 24, 1994.

The purpose of this review effort is to (i) Perform an assessment of the NRC's enforcement program to determine whether the defined purposes of the enforcement program are appropriate, (ii) determine whether the NRC's enforcement practices and procedures are consistent with those purposes, and (iii) provide recommendations on any changes the Review Team believes are advisable. It is expected that the Review Team will complete its review and issue its report, including recommendations, by the end of January 1995.

In the August 23, 1994 notice comments were requested on a variety of matters associated with the enforcement program. Item G. of the

notice, entitled "Exercise of Discretion," raised two issues associated with the exercise of enforcement discretion. However, a note was included under Item G. that provided that the enforcement review was not addressing section VII.C. of the Enforcement Policy entitled, "Exercise of Discretion for an Operating Reactor" that addresses "Notices of Enforcement Discretion" (NOEDs). 59 FR 43303 The Review Team has since reconsidered its position and concluded that this issue should be considered as part of the reexamination. Comments are now requested on this issue as described below.

On September 12, 1994, a report entitled, "Notice of Enforcement Discretion Review Team Report," was issued which addressed a number of issues associated with the issuances of NOEDs. The recommendations in this report have not yet been adopted by the NRC. The report and its recommendations are undergoing staff review. A copy of that report is available for inspection and copying in the Commission's Public Document Room. In addition it is available on the NRC bulletin board system (BBS) that is a subsystem of FedWorld. Access to the NRC BBS is described in the ADDRESSES section above.

In providing comments on the issue addressed below, please key comments to the numbering system used to identify the specific issues by providing the issue number before the particular comment (e.g., Response to K.1). General or anecdotal comments (such as a general comment to the effect that some enforcement conferences have not been effective or that some enforcement cases have been inconsistent with the Enforcement Policy) will not be particularly useful. Rather comments should be as specific as possible and should reference specific cases, as appropriate, so that the Review Team can understand and evaluate the comment. Responses which call for a "yes" or "no" answer should be accompanied with an explanation as to why the commenter agrees or disagrees with the issue. When the term licensee is used in the issues listed below, it refers, as applicable, to licensees, vendors, and other persons subject to NRC enforcement actions.

Comments may be provided in hard copy or through the NRC electronic bulletin board (BBS). Instructions for accessing the NRC BBS are provided in the ADDRESSES section above.

Comments are requested on the following specific issues:

#### K. Exercise of Enforcement Discretion for Operating Reactors

The NRC requires that a licensee operate its facility in compliance with the NRC's regulations and the specific facility's license. When a licensee fails to comply with the conditions of its license or the NRC's regulations, the staff normally takes enforcement action against that licensee in accordance with the NRC Enforcement Policy Section VII.C of the Enforcement Policy, 10 CFR part 2, appendix C, recognizes that on occasion circumstances may arise where a power reactor licensee's compliance with a technical specification limiting condition for operation or with other license conditions would involve an unnecessary plant transient or performance of testing, inspection, or system realignment that is inappropriate with the specific plant conditions, or unnecessary delays in start up without any corresponding health and safety benefits. In these circumstances it may be appropriate not to enforce the applicable requirements provided that the NRC is clearly satisfied that the action is consistent with protecting the public health and safety. Before issuing a NOED to a licensee, the licensee must justify the safety basis for the request and provide whatever information NRC deems necessary in making a decision as to whether to exercise this discretion. NOEDs are infrequently used and when issued are placed in the NRC Public Document Room. The use of enforcement discretion does not change the fact that a violation of a license requirement occurred. Under the Enforcement Policy, the NRC staff is to take enforcement action when it determines that there is an underlying violation that caused the need to seek the issuance of the NOED.

1. Under what circumstances should this type of enforcement discretion be exercised and why?

In addition to the above specific issues and those raised in the August 23, 1994 notice, commenters are invited to provide any other views on the NRC enforcement program which may assist the NRC in improving the effectiveness of NRC enforcement efforts.

Dated at Rockville, Maryland, this 21st day of September 1994.

For the Nuclear Regulatory Commission,  
James Lieberman,  
Director, Office of Enforcement.  
[FR Doc. 94-23821 Filed 9-26-94; 8:45 am]  
GALLSD CODE 7500-01-01

<sup>1</sup> This notice was corrected on September 6, 1994 (59 FR 48004), by deleting the reference to a "Proposed rule" appearing in the action line of the August 23, 1994 notice.

### *Appendix C: Legislative History of NRC Civil Penalty Authority*

The NRC's Enforcement Policy is set forth at Appendix C to 10 CFR Part 2: "General Statement of Policy and Procedures for NRC Enforcement Actions."<sup>1</sup> Section 234 of the Atomic Energy Act (AEA) of 1954, as amended, contains the CP provision. Issues focused on in this review of the legislative material include factors Congress enumerated as appropriate in determining actual amounts for CPs assessed, and what factors contributed to establishing a ceiling of \$100,000 for CPs. The AEA provides as follows:

#### Sec. 234.<sup>2</sup> Civil Monetary Penalties for Violations of Licensing Requirements.--

a. Any person who (1) violates any licensing provision of section 53, 57, 62, 63, 81, 82, 101, 103, 104, 107, or 109 or any rule, regulation, or order issued thereunder, or any term, condition, or limitation of any license issued thereunder, or (2) commits any violation for which a license may be revoked under section 186, shall be subject to a civil penalty, to be imposed by the Commission, of not to exceed \$100,000 for each such violation.<sup>3</sup> If any violation is a continuing one, each day of such violation shall constitute a separate violation for the purpose of computing the applicable civil penalty. The Commission shall have the power to compromise, mitigate, or remit such penalties.

b. Whenever the Commission has reason to believe that a person has become subject to the imposition of a civil penalty under the provisions of this section, it shall notify such person in writing (1) setting forth the date, facts, and nature of each act or omission with which the person is charged, (2) specifically identifying the particular provision or provisions of the section, rule, regulation, order, or license involved in the violation, and (3) advising of each penalty which the Commission proposes to impose and its amount. Such written notice shall be sent by registered or certified mail by the Commission to the last known address of such person. The person so notified

---

<sup>1</sup>The NRC published a proposed general statement of policy on October 7, 1980 and a final version on March 9, 1982. The last major revision was February 18, 1992 and the last program review was in 1985.

<sup>2</sup> Public Law 100-408 (102 Stat. 1066) (1988), Sec. 17 added Sec. 234A. Public Law 91-161 (83 Stat. 444) (1969), Sec. 4, added Sec. 234.

<sup>3</sup> Public Law 96-295 (94 Stat. 787) (1980), Sec. 206, amended Sec. (a) by striking all that followed "exceed" and inserted "\$100,000 for each violation." Prior to amendment, the portion deleted provided: "\$5,000 for each violation: *Provided*, That in no event shall the total penalty payable by any person exceed \$25,000 for all violations by such person occurring within any period of thirty consecutive days. If any violation is a continuing one, each day of such violation shall constitute a separate violation for the purpose of computing the applicable civil penalty."

shall be granted an opportunity to show in writing, within such reasonable period as the Commission shall by regulation prescribe, why such penalty should not be imposed. The notice shall also advise such person that upon failure to pay a civil penalty subsequently determined by the Commission, if any, the penalty may be collected by civil action.

c. On the request of the Commission, the Attorney General is authorized to institute a civil action to collect a penalty imposed pursuant to this section. The Attorney General shall have the exclusive power to compromise, mitigate, or remit such civil penalties as are referred to him for collection.

Section 234, in its initial form, was added to the AEA by Public Law 91-161 (83 Stat. 444) (1969), Sec. 4. The maximum CP for each violation initially was \$5,000, with a maximum of \$25,000 for all violations by the same person occurring within 30 days. As amended by Public Law 96-295, the statute now provides that the maximum CP is \$100,000 for each violation and that in the case of a continuing violation, the Commission may calculate the CP on the basis that each day the violation continues constitutes a separate violation (94 Stat. 787) (1980).

### **1. Public Law 91-161**

On December 24, 1969, the 91st Congress approved Public Law 91-161 which added Section 234, "Civil Monetary Penalties for Violations of Licensing Requirements," to the AEA. The Report of the Joint Committee on Atomic Energy (SR 91-533 and HR 91-691, November 24, 1969) noted that CPs would assist the Commission in carrying out its mission by providing flexibility to deal with infractions of varying severity. The report provided that a CP could be used ". . . where suspension or revocation of a license is not required, without depriving a licensee of his means of livelihood or without requiring the cessation of an unauthorized activity which might be of benefit to the public" (at 9-10).

The report also noted that CPs are ". . . primarily intended for application in circumstances where utilization of the other and generally stronger regulatory tools available to the Commission would be tantamount to swatting a fly with a sledge hammer" (at 10). It was pointed out as "worthy of special note" that this authority would not be confined to Commission licensees. "Any person, whether or not an AEC licensee, would be subject to such a [civil] penalty if he committed a violation of the type covered by the legislation" (at 11). The Joint Committee's report went on to state that "the authority to impose civil penalties on persons not possessing an AEC license . . . is necessary if the legislation is to achieve its full purpose" (at 11). In analyzing the legislation, the report stated that ". . . the penalties authorized are civil only and are remedial in nature as opposed to punitive" (at 16). This statement was made to contrast Section 234 with penalties issued under

Section 223, which ". . . are punitive, i.e., criminal in nature" (at 13). The report also stated that the 5-year statute of limitations in 28 USC 2462 would apply to Section 234 (at 16).

## 2. *Public Law 96-295*

On June 30, 1980, the 96th Congress approved Public Law 96-295, which modified Section 234 by raising the monetary ceiling to \$100,000 for each violation and removing the cap on civil penalties that may be imposed on any one person (as defined in the AEA) for violations occurring in any 30 consecutive day period.

In April 1978, the Commission unanimously approved recommendations for new legislation to amend Section 234 of the AEA, dealing with the NRC's authority to issue CPs. Previous authority under the AEA had limited CPs to \$5,000 for each violation or \$25,000 for all violations occurring in a 30-day period. The result of this recommendation to Congress was an AEA amendment that raised the NRC's maximum CP authority to \$100,000 per violation per day, and allowed administrative imposition of those CPs.

The NRC's reasoning, as presented in this recommendation, was basically three-fold. First, although existing CPs seemed effective for most cases, a few NRC licensees remained unresponsive, and the Commission believed that these licensees might have responded more effectively to higher CPs. Secondly, the \$5,000/\$25,000 limit did not, in the Commission's opinion, allow a spectrum of differentiated penalties commensurate with the many types of NRC licensees and the varying seriousness of violations. Thirdly, higher CPs were judged necessary to exert on large licensees (utilities and major industrial corporations) a deterrent effect comparable to the force of sanctions on economically small licensees, using the CP as a sanction of intermediate severity between an NOV and license revocation.

In addition to these central arguments, the Commission also observed that the increases in inflation, from 1969 to 1980, supported raising CPs to maintain financial relevance, and that other agencies (such as EPA, the Department of Transportation, the Food and Drug Administration, and the Consumer Product Safety Commission) had been given statutory authority for much higher maximum CPs than that provided the NRC in the AEA.

In the February 27, 1979, hearing before the House Subcommittee on Energy and Power of the Committee on Interstate and Foreign Commerce, NRC Chairman Hendrie commented that:

I think the way that we have looked at the use of these penalties in the past, not that we are really punishing people here. It is not a punitive sort of proposition[.]

It is a matter of getting people's attention.

There is generally a good deal of greater attention paid if there is money changing hands. If the format is a penalty being levied, the utilities don't like to have that kind of thing occur, and I think they do pay attention.

So we do use the civil penalties where we thought it necessary to drive the people harder, when they were not paying as much attention as we thought they should.

I think part of the reason that we thought some increase in the civil penalty authority was appropriate was, as time goes along and the dollar gets worth less, the \$25,000 penalty becomes trivial.<sup>4</sup>

In that same hearing, Mr. Michael Ward, Counsel for the House Subcommittee on Energy and Power, stated that, "[a]t the same time, the Commission is not assessing enough penalties. We could raise it to \$500,000, and it still would not be much of a deterrent. Two things have to happen. The penalties have to be real, and the threat of them being imposed has to be legitimate. I think the GAO [General Accounting Office] was raising some questions as to how vigorously the NRC was imposing some of the penalties, particularly in terms of coordinating or combining the fines into a single one."<sup>5</sup>

The June 4, 1980, Conference Report noted that some NRC licensees had been unresponsive to CP actions because the financial effects of NRC CPs on them were then "negligible." The conferees were persuaded that if the statutory ceiling on CPs were not increased, the high cost of replacement power (e.g., when a reactor is shut down for repairs or other corrective action) could continue to provide economic incentive to postpone compliance and incur the relatively low penalty.<sup>6</sup> The conferees also articulated their expectation that the Commission, when setting the amount of any penalty, would consider "...relevant factors such as the gravity of the violation, the financial impact of such fine on the licensee, good faith and the history of previous violations."<sup>7</sup>

---

<sup>4</sup>House Subcommittee on Energy and Power, at 283-84 (Feb. 27, 1979).

<sup>5</sup>House Subcommittee on Energy and Power, at 284 (Feb. 27, 1979).

<sup>6</sup>See General Accounting Office report to Congress of February 18, 1979: "Higher Penalties Could Deter Violations of Nuclear Regulations."

<sup>7</sup>H. Rept. 96-1070, at 34 (1980).



These same considerations had been noted by the Senate Committee on the Environment and Public Works. Specifically, on May 15, 1979, the Committee noted that the Commission perceived that higher CPs were needed as a corrective measure in relations with a few major NRC licensees who had been unresponsive to NRC's enforcement actions. Although the Commission conveyed that CPs were generally sufficient to influence utility attitudes, the NRC also perceived that larger licensees would respond better to higher penalties with escalated enforcement sanctions short of license suspensions. The Commission further conveyed that "...the present limits on civil penalties define too narrow a spectrum to accommodate a scale of penalties commensurate with the many types of licensees and the varying degrees [of] seriousness in violations." The Committee agreed that the maximum CP should be expanded to \$100,000 per violation without a ceiling for continuing violations.<sup>8</sup>

As to the report from the House Committee on the Interior and Insular Affairs, dated May 15, 1979, the Committee commented that the \$5,000 maximum then imposed was insufficient to deter certain violations of licensing terms and conditions. Both NRC and GAO recommended a CP of \$100,000 per day. The \$25,000 ceiling on total penalties for any period of 30 consecutive days was removed by Committee amendment, because any "cap" on penalties was viewed as lessening the deterrent value inherent in the authority to impose CPs. Similar to the factors noted in the subsequent Conference Report (discussed above) it was viewed that in determining the amount of any penalty, the Commission must consider relevant factors such as the gravity of the violation, size of the licensee, good faith, and history of previous violations.<sup>9</sup>

---

<sup>8</sup>S. Rept. 96-176, at 23 and 24 (1979).

<sup>9</sup>H. Rept. 96-194, Part 1, 11 (1979).

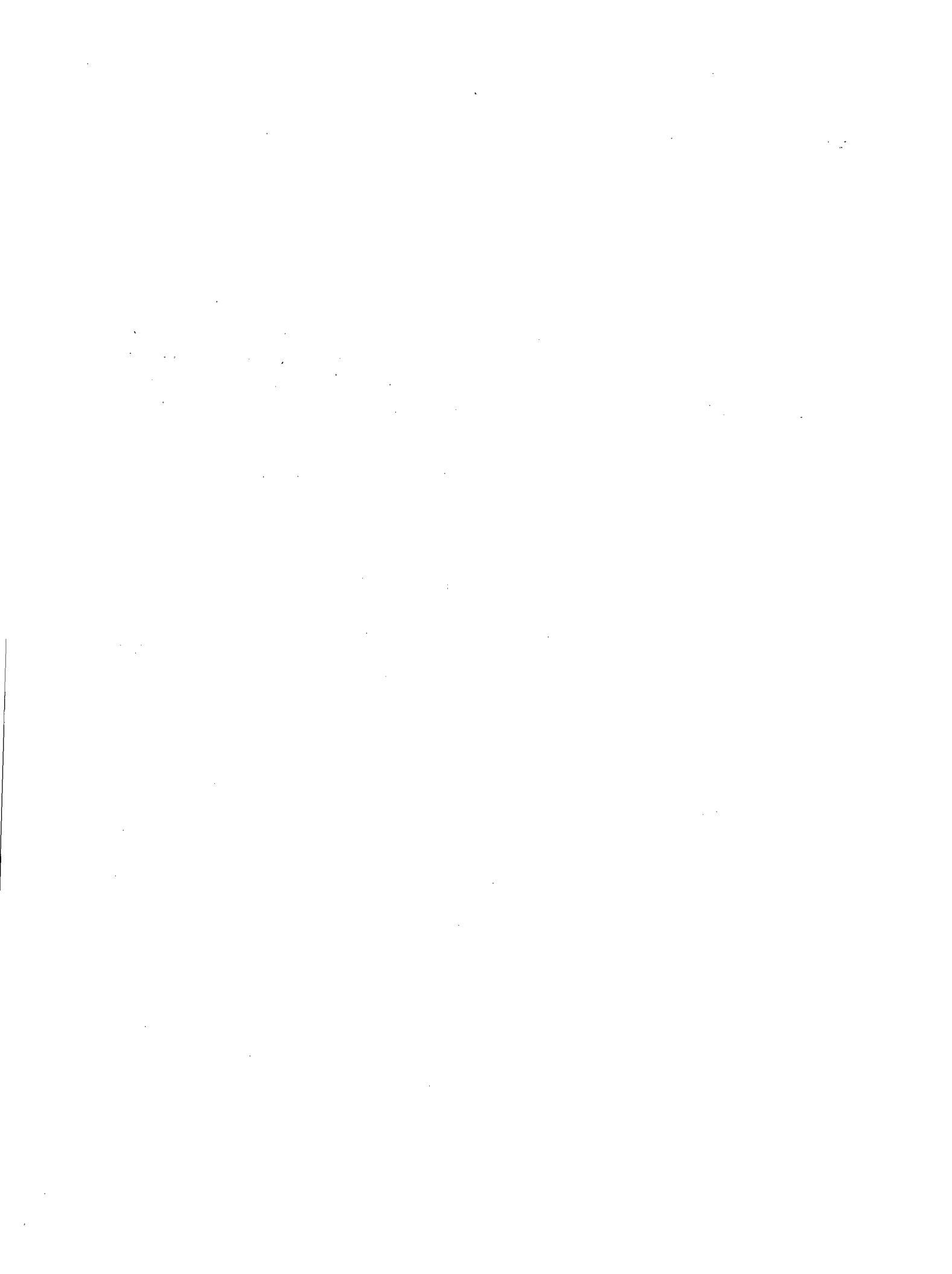

**Appendix D: History of the Enforcement Policy****1. History of Enforcement Policy Revisions****a. Atomic Energy Act Authority**

The Atomic Energy Act (AEA) of 1954, as amended, provides the Commission with authority to take appropriate enforcement action for violations of Commission requirements. Section 161 authorizes the NRC to conduct inspections and issue any orders "necessary or desirable to protect the common defense and security or to protect health or to minimize danger to life or property." Section 186 authorizes the NRC to revoke or suspend licenses under certain circumstances of licensee noncompliance. Section 234 authorizes the NRC to impose CPs for licensee noncompliance with certain license conditions and regulations specified under the AEA. Section 223 establishes criminal penalties applicable to certain individuals who willfully violate the AEA in a manner that could, under specified conditions, significantly and adversely affect a licensed nuclear facility's operations.

**b. Documents Pre-Dating the Enforcement Policy (1972-1980)**

The first versions of the Enforcement Policy were staff documents giving guidance on how enforcement actions should be prepared and issued to licensees of the NRC and its predecessor, the Atomic Energy Commission (AEC). The experience gained in using these criteria helped to shape the guidance issued as a formal Commission Enforcement Policy in October 1980.

**(1) "Criteria for Determining Enforcement Action" (1972) (37 FR 21962)**

On November 1, 1972, the AEC issued to all its licensees a document entitled "Criteria for Determining Enforcement Action." This guide emphasized the objectives of safety and reliability in operating nuclear power plants, fuel facilities, and materials programs, and highlighted the importance of vigorous licensee quality assurance programs as a primary step toward achieving these objectives. Recognizing, however, that licensee efforts do not always result in compliance with regulatory requirements, the guide set out criteria for taking specific enforcement actions commensurate with the violations that occur.

The 1972 guide gave general criteria for issuing NOVs, CPs, and orders. NOVs were to be given for procedural, readily correctable, or initial (or infrequent) violations that did not pose an immediate and serious threat to public or employee

health and safety. CPs were considered appropriate for repetitive issues, willful violations, or cases where ineffective corrective actions or a history of recurring safety deficiencies demonstrated a lack of adequate licensee concern with public and employee health and safety. CPs were also considered appropriate when additional punitive action above a "cease and desist" order was deemed necessary, or in cases where a violation contributed to the seriousness of an accident or radiological incident. Orders were to be considered for more serious situations, such as where immediate action was deemed necessary to protect public health and safety.

(2) *"Guidance for the Assessment of Civil Penalties" (1972)*

In addition to the "Criteria" sent to licensees, the AEC prepared an accompanying internal guide entitled "Guidance for the Assessment of Civil Penalties." This guide, as well as the schedule for determining CP amounts, was not made public. It was based on the relatively limited experience in regulating complex nuclear operations, the rapid evolution of standards governing performance, and the consequent problems of establishing sound measurement bases.

In assessing CPs, the guide outlined three violation categories (or severity levels)--based on probability and potential safety consequence--and listed 123 examples, with severity levels noted, for violations of various regulations and license conditions. Licensees were divided into five groups (ranging from power reactors to medical licensees), and a range of CP amounts was specified for each type of licensee and each severity level. "Judgment factors" were to be used in determining the actual CP amount, including the violation severity, the number of violations, past performance, the frequency of violations, the duration of the violation, corrective actions taken and proposed, and whether the violation was repetitive. In addition, general procedures were given for issuing the NOV, proposing and imposing the CP, and taking associated actions.

On June 5, 1973 the AEC issued a followup notice to all licensees that outlined the three violation categories. NOVs issued after that time were assigned a severity category.

(3) *"Criteria for Determining Enforcement Action" (1974 Revision)*  
*(40 FR 820, January 3, 1975)*

The first revision of the "Criteria for Determining Enforcement Action" was issued on December 31, 1974. This revision was issued by the staff after consultation

with the Commission, and provided the first statement of the purpose of the enforcement program (" . . . enhancement of the health and safety of the public, the common defense and security, and the environment . . . ." as well as an emphasis on corrective action). It divided noncompliances into three distinct categories--"Violations," "Infractions," and "Deficiencies"--and introduced the term "deviation" to mean a departure from a licensee commitment, industry code, or standard that did not constitute a legal violation. Regulatory Operations Bulletins and Immediate Action Letters were also introduced as methods of requesting specific licensee actions or soliciting (or confirming) licensee commitments. Finally, this revision emphasized the importance of reporting requirements, with the failure to report a violation constituting, in itself, a noncompliance of the same severity level.

**(4) "Enforcement Actions": IE Manual Chapter 0800 (1975)**

On January 17, 1975, the NRC Office of Inspection and Enforcement issued a detailed internal procedure (Chapter 0800 of the Inspection and Enforcement Manual) on enforcement actions. This document outlined the same general structure of enforcement sanctions, but provided more detailed definitions, specific procedures for various sanctions, and samples of licensee correspondence, NOVs, and orders. The objective of the enforcement program, as stated in this document, was "... to ensure maximum compliance practicable with Commission requirements through consistent application of reasonable sanctions in accordance with uniform procedures." The statement of purpose also noted that "punitive sanctions are imposed on recalcitrant offenders."

**(5) "Criteria for Enforcement Action for Failure to Comply with 10 CFR 71" (1979) (44 FR 77135, December 3, 1979)**

On December 3, 1979, the Director of the Office of Inspection and Enforcement issued to all NRC licensees guidelines to be used to determine enforcement action in the area of enforcement. It introduced four severity levels and provided for CPs at the higher levels. This guidance followed the issuance of amended regulations in October 1979 to address packaging and shipment of radioactive material for transportation.

**c. Enforcement Policy: 10 CFR 2, Appendix C (1980) (46 FR 66754, October 7, 1980)**

Public Law 96-295 amended the AEA on June 30, 1980 to raise the maximum CP from \$5000 to \$100,000. The Commission had already begun to consider publishing a

comprehensive statement of enforcement policy, and the AEA amendment provided further impetus for a significant update of the enforcement program. On October 7, 1980, the first Enforcement Policy was published in the *Federal Register*, to be later codified as Appendix C to 10 CFR 2.

The new Enforcement Policy's stated goals included ensuring compliance, obtaining prompt correction of licensee weaknesses, deterring future noncompliance through strong enforcement measures, and encouraging improvement of licensee performance. The Commission's stated intent was to have an enforcement program marked by "an aggressive enforcement strategy that seeks more frequent use of stronger enforcement measures," one that would ensure that "noncompliance is more expensive than compliance." Proposed actions under the new Policy were especially aggressive for more severe violations; the outlined progression of escalated enforcement sanctions included suspension of affected operations and "show cause" orders for repeated similar violations in a given activity area.

The structure of enforcement actions under the new Policy was modified and more detailed. All noncompliances with regulations and license conditions were now called violations. Six severity levels were outlined, with examples given for each level in seven activity areas ranging from Reactor Operations to Transportation. Base CPs were outlined for SLs I through V, differentiated for four separate types of licensees. These differences in proposed base CPs were based on the potential public safety impact of noncompliance, and on the licensee's ability to pay. For power reactors, the base CP amounts ranged from \$80,000 (for a SL I or II) to \$5000 (for an SL V).

Other changes included introducing enforcement conferences as an informal enforcement mechanism, specifying circumstances under which violations might not be cited, outlining actions that could be taken against licensed operators, listing situations that required Commission consultation, and using specified percentages for certain CP adjustment factors. If a licensee identified, corrected, and reported (where necessary) a violation in a timely fashion and prior to NRC discovery, the CP could be reduced by as much as 50%. A missed prior opportunity to identify the violation could result in up to 25% escalation. On the other hand, up to 25% special mitigation could be applied for licensee "good faith" (i.e., if the violation was the result of an honest mistake), so long as the licensee also took extraordinary corrective measures to prevent recurrence. Finally, the CP could be increased up to 100% per day for a violation that continued more than one day.

The Commission requested public comment on the new Policy, and approved it as interim staff guidance. Five public meetings were held across the country to discuss

the Policy. Public comments ranged from enthusiastic to highly critical; principal criticism included: (1) the perceived adversarial tone of the new Policy; (2) the lack of flexibility given to consider extenuating licensee circumstances; (3) inadequate recognition of licensee self-monitoring programs; (4) inconsistency among severity levels as applied to various activity areas; (5) lack of clarity in certain severity level examples; and (6) inadequate distinctions between the more minor severity levels.

Significant revisions to the Enforcement Policy are listed below.

**(1) 1982 Enforcement Policy Revision (47 FR 9987, March 9, 1982)**

On March 9, 1982 the Commission published a revision to the Enforcement Policy that reflected consideration of public comments and experience gained in interim implementation. The wording introducing the Policy was revised to take a less adversarial tone. The number of severity levels was reduced from six to five. A provision was inserted that SL I, II, and III violations would be considered for CPs. A provision was also added clarifying that effective licensee self-monitoring (i.e., self-identification, corrective action, and reporting) could result in no CP being issued for a given violation.

Under this revision, the CP adjustment factors were itemized as: (1) Prompt Identification and Reporting--50% mitigation; (2) Corrective Action to Prevent Recurrence--50% mitigation, 25% escalation; (3) Enforcement History--25% escalation; (4) Prior Notice of Similar Events--25% escalation; and (5) Multiple Occurrences--25% escalation. The duration of a violation, while not assigned a percentage value, was also to be considered in determining the CP amount. Specific criteria for actions against licensed operators were removed. The supplements on fuel cycle operations and materials activities were combined, and a new "Miscellaneous" supplement was added covering material false statements, willful violations, and reporting requirements.

**(2) 1984 Enforcement Policy Revision (49 FR 8583, March 8, 1984)**

In a March 8, 1984 revision to the Policy, the Commission made several minor changes, most involving clarification of practice. Language was added to reflect the practice of evaluating several violations in the aggregate and assigning a single severity level to the group. The enforcement conference (EC) discussion was expanded to delineate the purpose of the ECs and the information to be discussed at ECs. Percentages were increased for CP adjustment factors. Based on the decisions in *Consolidated X-Ray* and *Atlantic Research*, the Policy was modified

to state that, while a CP could be increased for management involvement, the lack of management involvement was not considered a basis for CP reduction. Finally, a new supplement was added, giving examples of violations in the area of Emergency Preparedness.

**(3) 1985 Modified Enforcement Policy**

The Commission authorized the NRC's Director of Licensing to issue a generic letter (GL) announcing the Commission's intention on how it was going to exercise its enforcement discretion in enforcing environmental qualifications requirements under 10 CFR 50.49. GL 85-15 was issued on August 6, 1985. This generic letter was subsequently modified on April 7, 1988, by GL 88-07.

**(4) 1985 Enforcement Policy Revision (50 FR 47716, November 20, 1985)**

The next revision, issued on November 20, 1985, reflected a Commission decision to add a section on vendor enforcement to support an increased focus on NRC inspection and oversight of industry vendor activities--architect engineers, manufacturing firms, testing facilities, and suppliers of equipment, parts, and services. Various sections of the Policy, including the purpose and supplements, were expanded to encompass vendor activities. References to the Notice of Nonconformance to vendors were added to the section on Enforcement Actions.

**(5) 1987 Enforcement Policy Revision (52 FR 36215, September 28, 1987)**

In conjunction with approving the March 1984 revision to the Policy, the Commission had decided to establish a committee of outside experts to review the Policy and provide recommendations for change. The committee was formed in August 1984 and provided recommendations to the Commission in November 1985. Based on a review of these recommendations and continued experience with implementing the Policy, the Commission issued another Policy revision on September 28, 1987.

The 1987 revision focused on several areas. The basis for enforcement actions against individuals (including licensed operators) was clarified, and the related guidance was expanded to give examples of (1) situations that *could* result in individual enforcement actions (e.g., willful violations, operator inattentiveness); (2) situations that generally would *not* result individual enforcement actions; and (3) types of sanctions that might be considered appropriate against NRC-licensed operators. This revision also added an expanded section on Exercise of Discretion



for violations occurring under specified conditions for plants in extended shutdown or work stoppage. Guidance was included on reopening closed enforcement cases.

**(6) 1987 Enforcement Policy Revision (52 FR 49362, December 31, 1987)**

The Commission revised its Enforcement Policy to address violations of the rule on Complete and Accurate Information.

**(7) March 1988 Enforcement Policy Revision (53 FR 9429, March 23, 1988)**

On March 23, 1988 the Commission modified the Enforcement Policy to clarify its policy on reopening closed enforcement actions.

**(8) October 1988 Enforcement Policy Revision (53 FR 40019, October 13, 1988)**

On October 13, 1988 the Commission issued its next Enforcement Policy revision. This revision further expanded the guidance on Exercise of Discretion, including three SL III situations where issuing a CP might not be appropriate: (1) licensee identified and corrected violations that are non-willful, not indicative of a management control breakdown, and not involving overexposures or excessive release of radioactive material; (2) past violations that are unlikely to be identified during routine quality assurance activities, where aggressive licensee action is responsible for identification; and (3) additional occurrences of a violation for which enforcement action has already been taken (i.e., additional occurrences discovered as part of the licensee's corrective action investigation).

The 1988 revision expanded the guidance on several CP adjustment factors: (1) to allow escalation for NRC identification; (2) to specify a time period for considering past performance, and to allow more flexibility in applying this factor; (3) to permit escalation of up to 100% for prior notice and multiple examples; (4) to designate duration as an adjustment factor; and (5) several other minor changes. Changes were also made to several examples in the supplements: significantly, the Reactor Operations supplement was modified to emphasize the severity of operating in an unanalyzed condition, and an example was added to several supplements of an SL III problem for cases in which "... multiple or recurring violations ... collectively reflect a potentially significant lack of attention or carelessness toward licensed responsibilities."

**(9) 1989 Enforcement Policy Revision (54 FR 24468, June 7, 1989)**

On June 7, 1989 the Commission modified the Enforcement Policy to reflect fitness-for-duty violations.

**(10) 1989 Enforcement Policy Revision (54 FR 50610, December 8, 1989)**

In December 1989 the Commission issued an Enforcement Policy revision of limited scope, directed toward emphasizing the focus on improving licensee maintenance programs. The revision added a CP adjustment factor of +50% for significant violations for which the root cause involved a maintenance failure.

**(11) 1990 Enforcement Policy Revision (55 FR 843, January 10, 1990)**

The Commission modified its Enforcement Policy to reflect revised standards for radiography equipment in 10 CFR Part 34.

**(12) 1990 Enforcement Policy Revision (55 FR 31113, July 31, 1990)**

The Commission issued a separate Enforcement Policy to treat exposure from hot particles. This policy is in effect until the issue of hot particles is incorporated into 10 CFR Part 20.

**(13) 1991 Enforcement Policy Revision (56 FR 23360, May 21, 1991)**

The Commission modified its Enforcement Policy to reflect revised standards for protection against ionizing radiation in 10 CFR Part 20.

**(14) 1991 Enforcement Policy Revision (56 FR 32066, July 15, 1991)**

The Commission modified the Enforcement Policy to reflect fitness-for-duty requirements for licensed operators.

**(15) 1991 Enforcement Policy Revision (56 FR 34121, July 25, 1991)**

The Commission modified the Enforcement Policy to reflect the quality management requirements in 10 CFR Part 35.

**(16) 1991 Enforcement Policy Revision (56 FR 36998, August 2, 1991)**

The Commission modified the Enforcement Policy to add a severity level example to address maintenance and delete the maintenance CP adjustment factor.

**(17) 1991 Enforcement Policy Revision (56 FR 40664, August 15, 1991)**

The Commission modified the Enforcement Policy to reflect the rule on Deliberate Misconduct.

**(18) 1992 Enforcement Policy Revision (57 FR 5791, February 18, 1992)**

The most recent major revision to the existing Enforcement Policy was issued in February 1992. The modification reflected the reorganization of enforcement functions and clarified the responsibilities of the DEDOs, OE, and other offices conducting inspection activities. Expanded guidance on severity levels was included, specifying criteria for escalating a violation's severity based on willfulness, repetitiveness, or aggregation. Base CPs were proposed for SL IV violations, and CPs for SL V violations were eliminated.

The use of enforcement discretion was expanded in this revision, providing for (1) increases or decreases in CPs after application of the standard guidance; (2) use of discretion for SL II violations; and (3) use of NCVs for licensee-identified and corrected willful violations of low safety significance committed by relatively low-level individuals. Minimum CPs were established for certain overexposures and loss or release of licensed material. Additional examples were added to Supplements I, VI, and VIII, and the Supplement III (Safeguards) examples were revised to better focus on safety significance.

In addition, further changes were made to the CP adjustment factors. The "Identification and Reporting" factor was changed to eliminate reporting as a consideration (noting that a reporting failure would instead be considered for a separate violation). "Identification" was also clarified to allow 25% mitigation for a self-disclosing event. "Corrective Action" was expanded to consider both immediate and long-term corrective action. Guidance on past performance was expanded to focus on overall "licensee performance." "Prior Opportunity to Identify" was revised to specifically allow consideration of the licensee's opportunities for identifying the violation through surveillances, audits, and other internal findings. "Multiple Occurrences" was clarified to apply normally only when the violations under consideration had the same root cause. "Duration" was

broadened to include not only continuing violations, but single violations for which the impact continued for more than one day.

**(19) 1993 Enforcement Policy Revision (58 FR 14308, March 17, 1993)**

The Commission modified the Enforcement Policy to reflect its policies on Notices of Enforcement Discretion.

**(20) 1993 Enforcement Policy Revision (58 FR 17321, April 2, 1993)**

The Commission modified the Enforcement Policy to reflect revisions to severity levels concerning violations of the quality management program under 10 CFR Part 35.

**(21) 1994 Enforcement Policy Revision (59 FR 36026, July 15, 1994)**

The Commission modified the Enforcement Policy to reflect revisions to its regulations requiring timely decontamination and decommissioning by nuclear materials licensees.

**(22) 1994 Enforcement Policy Revision (59 FR 60697, November 28, 1994)**

The Commission modified the Enforcement Policy to reflect issues associated with discrimination.

**2. Notice of Violation: Evolution as an Enforcement Tool**

**a. Severity Levels: Timeline**

September 7, 1972: In an internal document called "Guidance for the Assessment of Civil Penalties," the AEC Regulatory Operations office designated three categories of violations, based on the probability of occurrence and the potential hazard of the consequences. Category I violations were those involving **actual or likely** hazardous consequence (i.e., radiation exposures or radioactive materials releases in excess of permissible limits). Category II violations were those involving **potential** safety consequence. Category III was to be used for those violations involving documentation, posting, or readily correctable procedural matters. A table enclosed in this guidance gave 123 examples of possible violations, with the category designated for each.

June 5, 1973: The AEC issued a followup notice to all licensees that publicly outlined the three violation categories. The table of examples was not included in this correspondence. NOVs issued after that time were assigned a severity category.

December 31, 1974: In a revision to its "Criteria for Determining Enforcement Action," the AEC assigned a different name to each of the three categories of severity. The most serious noncompliances were called "violations," and involved those failures to comply that had caused, contributed to, or aggravated a serious incident (such as an overexposure, exceeding a technical specification safety limit, diversion or theft of special nuclear material, etc.), or that had significant potential to cause, contribute to, or aggravate such an incident. An "infraction"--the term assigned to the second category--was a failure of a similar nature but with less significant consequences. "Deficiency" was the term assigned to the least serious category, such as posting, labeling, and record-keeping noncompliances. Although these different terms were used, each category was recognized to constitute a legal violation. In addition, the term "deviation" was introduced to mean a departure from a licensee commitment, industry code, or standard that did not constitute a legal violation.

December 3, 1979: In correspondence to all licensees, the NRC issued specific enforcement criteria for failures to comply with 10 CFR 71. This guidance outlined four severity levels, with examples given for each. SL I and II problems were considered "violations" (under the 1974 terminology), SL III corresponded to "infractions," and an SL IV noncompliance was considered a "deficiency."

October 7, 1980: With the issuance of the first formal Enforcement Policy came an expansion to six violation severity levels. The differentiation in terms (i.e., use of "infraction" and "deficiency") was dropped. SL I, II, and III violations were those considered to be of significant regulatory concern: that is, those that could involve actual or "high potential" impact on the public. SL IV violations included degradation of engineered systems or management controls designed to detect, prevent, or mitigate an event; although not inherently significant concerns, these violations were those that, if left uncorrected, could lead to matters of significant concern. SL V was assigned to less serious violations (e.g., procedural errors) with other than minor safety or environmental significance. SL VI violations were those considered of minor significance.

March 9, 1982: The first revision to the Enforcement Policy reduced the number of severity levels to five (basically combining the former categories of SL IV and SL V). Although the examples given in the supplements have been variously modified, augmented, or even eliminated in later revisions, the basic severity level structure

outlined here has remained the same. In general terms, SL I and II violations were those considered cause for very significant regulatory concern, SL III cause for significant concern, SL IV less serious but of more than minor concern, and SL V of minor concern.

***b. Exercise of Enforcement Discretion***

From its inception, the enforcement program has been considered guidance rather than a prescriptive formula. The concept of Commission discretion (to deal on a case-by-case basis with unusual situations or situations without apparent precedent) has been consistently implied or stated in the various iterations of agency enforcement policy. This assumption has been articulated both in a general sense (i.e., treating the overall Policy as guidance rather than a rule) and in more specific, spelled-out methods of exercising discretion.

***(1) General Discretion: Timeline***

March 9, 1982: In this early revision, which codified the Enforcement Policy as Appendix C to 10 CFR 2, the Commission explicitly stated that the Policy "... is intended to serve as Commission guidance, rather than as rigid requirements."

October 13, 1988: The introduction to this revision reemphasized the status of 10 CFR 2, Appendix C as a policy rather than a rule, and explicitly stated that "[t]he Commission may . . . deviate from the Enforcement Policy as is appropriate under the circumstances of a particular case." This revision added a similar statement to the Policy itself (still included in the present version), to avoid any implication of the Policy being taken as a binding regulation.

***(2) Circumstances Beyond Licensee Control: Timeline***

December 31, 1974: In the letter transmitting this revision to the early "Criteria for Determining Enforcement Action," the AEC noted that the enforcement program applied to licensees' failures to meet a regulation or commitment. However, certain events (e.g., equipment malfunctions) were recognized as not being "... founded in the failure of the licensee to meet requirements . . ." and therefore were to be considered outside the scope of the enforcement program.

October 7, 1980: The above concept was clarified in the Enforcement Policy. Licensees are not normally cited for violations that result from matters outside

their control, if the problem could not reasonably have been foreseen. This statement has been included in all later revisions of the Policy.

**(3) *Non-Cited Violations (NCVs): Timeline***

October 7, 1980: This first version of the Enforcement Policy introduced the NCV concept. In general, this policy stated that a notice would not normally be issued for a violation that was licensee-identified, of a low level of significance (SL V or VI), reported (if required), and corrected in a timely manner.

March 9, 1982: This revision included an additional caveat, excluding repetitive violations from being treated as NCVs.

October 13, 1988: An additional provision for NCVs was included here, allowing use of an NCV for an NRC-identified SL V violation, so long as it was corrected in a timely manner and was not repetitive or willful.

February 18, 1992: Specific circumstances were detailed here under which a willful SL V violation might be considered for NCV status. In addition, for an SL V violation to be considered an NCV, the corrective actions no longer need to be completed before the inspection's end, so long as they will be completed in a reasonable time.

**(4) *Discretion for SL III and Above Violations: Timeline***

September 28, 1987: This revision added a new section to the Enforcement Policy entitled "Exercise of Discretion," which described for the first time circumstances under which a licensee in extended shutdown might not be issued an NOV and/or CP for an SL III violation. The discretion only applied when events leading to the shutdown had been already accompanied by significant NRC enforcement action, and the licensee was attempting to aggressively identify and correct underlying problems. In addition, this discretion could only be applied to non-willful violations that were based on licensee activities occurring before the events leading to shutdown.

October 13, 1988: Several additional situations were described here in which NRC discretion would be appropriate for SL III violations. These included (1) non-willful, non-repetitive violations that the licensee identified and promptly, comprehensively corrected (other than overexposures and releases); (2) violations involving past engineering, design, or installation problems, identified as the result

of a voluntary formal licensee effort; and (3) violations discovered as the result of aggressive licensee effort to identify the root cause of an earlier SL III violation. In addition to these examples, this revision specifically noted the staff's discretion, under certain conditions, to classify as SL IV a violation that would normally be classified as SL III.

February 18, 1992: This revision expanded the enforcement discretion guidance in several ways. The previous examples for exercising discretion were expanded to include SL II violations. In addition, the staff was given more general flexibility in escalating or mitigating a CP to achieve a different result than that suggested by applying the CP adjustment factors. A provision was also included for assessing daily violations (with daily CPs) for egregious cases.

**(5) Notice of Enforcement Discretion (NOED)**

March 17, 1993: This version added Section VII.C, entitled, "Exercise of Discretion for an Operating Facility." It established the use of NOEDs for circumstances in which the licensee's compliance with a license condition (e.g., a technical specification Limiting Condition for Operation) would involve an unnecessary plant transient or would require performing a test, inspection, or system realignment inappropriate for the existing plant conditions. In such cases, a licensee request for discretion will be considered by the Regional Administrator or, if appropriate, by the Director of NRR.

**c. Violations Involving Willfulness: Timeline**

October 7, 1980: This first version of the Enforcement Policy established as guidance that willful violations would normally be considered for a CP.

March 9, 1982: In this revision, a paragraph was added to note that the severity of a violation might be increased for willfulness. In assessing the amount of weight to be given for willfulness, the position of the person involved, the intent of the violator, and any economic advantage to be gained by the violation were factors to be considered. Examples of willful violations were added to a new supplement on miscellaneous matters.

March 8, 1984: The examples of willful violations in Supplement VII were expanded and clarified.

September 28, 1987: In providing expanded guidance on actions that could be taken



against individuals, this revision of the Policy detailed several examples of willful violations.

October 13, 1988: The examples of willful violations in Supplement VII were again expanded and clarified.

February 18, 1992: The discussion of willfulness was expanded in a new section added under "Severity of Violations." This revision provided that a willful SL V violation be classified at least at an SL IV.

*d. Enforcement Actions Involving Individuals: Timeline*

October 7, 1980: The initial Enforcement Policy briefly described circumstances in which an NOV might be issued to an operator, and noted that egregious single violations or repeated involvement in significant enforcement actions could result in revocation or suspension of an operator's license.

March 9, 1982: This revision removed the earlier description of actions to be taken against licensed operators, and replaced it with a statement that enforcement actions against individuals (including licensed operators) would be treated case by case. It also noted that licensees are generally held responsible for employee actions.

September 28, 1987: This revision included an expanded section on "Enforcement Actions Against Individuals." This section included discussions of the basis for individual action, the importance of integrity, and the culpability of management in causing individuals to be in violation. Examples were given of when enforcement action against an individual would and would not normally be considered. Examples were also given of enforcement sanctions that might be considered appropriate against NRC-licensed operators.

**3. Civil Penalties**

*a. Amounts: Timeline*

September 7, 1972: This internal document, entitled "Guidance for the Assessment of Civil Penalties," provided the first guidance on uniform CP assessment. As provided under the AEA, the maximum allowable CP was \$5000 per violation per day, up to a maximum of \$25,000 during a 30-day period. Table II, provided as an attachment, gave a range of CP considered appropriate at each severity level for each of five classes of licensees.

June 30, 1980: Public Law 96-295 amended to Section 234 of the AEA to raise the maximum CP to \$100,000 per violation per day, and to eliminate the limit of \$25,000 within a 30-day period.

October 7, 1980: The first guidance published as a comprehensive Enforcement Policy reflected the newly increased CP authority, and provided as Table 1 a schedule of base CPs at different severity levels for four general classes of licensees. For power reactors, the base CP for SL I and II was \$80,000; the base CP for an SL III was \$40,000.

March 9, 1982: This revision divided licensees into eight classes for the purpose of assigning CPs. Base CP amounts were redesignated for SL I violations, and the amounts for SL II, III, IV, and V violations were assigned, respectively, as 80%, 50%, 15%, and 5% of the SL I base CP amount. Separate base CP amounts were provided for violations in the areas of safeguards and transportation (i.e., as opposed to plant operation and health physics).

March 8, 1984: For this revision, the number of licensee classes was increased to nine, and the base CP amounts were changed for certain licensees. The SL I base CP for power reactors was raised to \$100,000.

February 18, 1992: CPs were eliminated for SL V violations.

**b. Adjustment Factors: Timeline**

September 7, 1972: This initial "Guidance for the Assessment of Civil Penalties" did not specify particular CP adjustment factors or percentages for escalation and mitigation. Instead, general "judgment factors" were given, and the "criteria for imposing civil penalties" discussed repetitive violations, untimely corrective action, willfulness, a licensee history of chronic violation, and inadequate management controls.

December 31, 1974: This version of the "Guidance" added the failure to report a significant violation as a factor to be considered in assessing a CP.

October 7, 1980: This initial version of the Enforcement Policy stated that, besides severity level, the amount of a CP should reflect the duration of the violation, the method of identification, the financial impact of a CP on the licensee, the licensee's "good faith," the licensee's prior enforcement history, and whether the violation was willful. Timely identification, correction, and (if required) reporting would result in

mitigating as much as 50% of the base CP amount. Prior opportunity to identify the violation through an NRC inspection or licensee audit was considered for 25% escalation, and the licensee acting in "good faith" could result in 25% mitigation.

March 9, 1982: Under this revision, the CP adjustment factors were itemized as: (1) Prompt Identification and Reporting--50% mitigation; (2) Corrective Action to Prevent Recurrence--50% mitigation, 25% escalation; (3) Enforcement History--25% escalation; (4) Prior Notice of Similar Events--25% escalation; and (5) Multiple Occurrences--25% escalation. The duration of a violation, while not assigned a percentage value, was also to be considered in determining the CP amount. Violations found through self-disclosing events were specifically excluded from consideration for self-identification credit.

March 8, 1984: Several changes to the adjustment factors appeared in this revision. Partial identification credit was allowed for self-disclosing events, depending on the ease of discovery. Escalation for Corrective Action, Prior Notice, and Multiple Occurrences was increased from 25% to 50%. Past Performance was changed to allow up to 100% mitigation or escalation, and was expanded in scope, including calling for consideration of enforcement history and recent SALP scores. In addition to these factors, CP escalation could occur because of willfulness, flagrant NRC-identified violations, repeated poor performance, or a serious breakdown in management controls.

October 13, 1988: The Identification and Reporting factor, in this revision, was changed to allow 50% escalation for NRC identification of the violation. The amount of potential escalation for Prior Notice and Multiple Examples was increased to 100% for each. Duration was added as a specific factor, allowing up to 100% escalation for cases in which the duration was significant and daily CPs were not assessed.

December 8, 1989: This narrowly-focused revision added a seventh CP adjustment factor, allowing escalation of up to 50% for maintenance-related violations at a power reactor where a root cause involved a programmatic failure.

February 18, 1992: This version made several significant changes to the CP adjustment factors. The "Maintenance-Related Cause" adjustment factor was dropped. The "Identification and Reporting" factor was changed to eliminate reporting as a consideration (noting that a reporting failure would instead be considered for a separate violation). In addition, 25% mitigation was specified as an appropriate credit for licensee identification stemming from a self-disclosing event. "Corrective Action" was expanded to consider both immediate and long-term actions. Guidance on past performance was expanded to focus on overall "licensee performance." "Prior

"Opportunity to Identify" was revised to specifically allow consideration of opportunities the licensee had to identify the violation through surveillances, audits, and other internal findings. "Multiple Occurrences" was clarified to normally apply only when the violations under consideration had the same root cause. "Duration" was broadened to include not only continuing violations, but single violations for which the impact continued for more than 1 day.

*c. Applying Adjustment Factors to Severity Level I and II Violations: Timeline*

March 9, 1982: Under this revision, adjustment factors were not applied to SL I and II violations.

March 8, 1984: The Policy was changed to allow application of adjustment factors to SL II violations.

September 28, 1987: Under this revision, adjustment factors were applied to SL I violations to encourage self-identification and reporting, extensive corrective actions, and good performance by a licensee.

*d. Cost of Noncompliance: Timeline*

October 7, 1980: This policy provided that it should be implemented in a way "that assures that noncompliance be more expensive than compliance."

March 9, 1982: This revision stated, "It is the Commission's intent that noncompliance should be more expensive than compliance."

March 8, 1994: In this revision, the Commission changed the language to: ". . . sanctions should be designed to ensure that a licensee does not deliberately profit from violations of NRC requirements." This change was made to clarify the original intent that licensees committing deliberate violations should receive higher sanctions to remove any benefit attributable to the violation. The Commission was concerned that the earlier language could significantly increase sanctions for inadvertent violations.

September 28, 1987: The Commission removed reference to this language on the basis that the wording was ambiguous, there were few applicable cases, and the policy allowed increasing CPs for deliberate violations.

#### **4. Other Enforcement Actions and Related Activities**

##### **a. Orders: Timeline**

September 7, 1972: The initial "Criteria for Determining Enforcement Action" outlined the basic criteria for issuing an order to modify, suspend, or revoke a license. Cease and Desist orders were deemed appropriate to stop an individual knowingly conducting unauthorized activity or conducting authorized activity in a way that endangered the health, safety, or interest of other employees or the public. General provisions for granting hearings (and for taking action before a hearing for cases requiring immediate change) were also outlined.

##### **b. Confirmatory Action Letters: Timeline**

December 31, 1974: This early revision to the "Criteria for Determining Enforcement Action" discussed the use of Regulatory Operations Bulletins and Immediate Action Letters as a means of accomplishing voluntary licensee action to investigate, report, and commit to correct problems. A Bulletin was issued to request action for a generic class of licensees. An Immediate Action Letter was issued to solicit or confirm the action of a particular licensee in controlling and/or correcting a problem.

October 7, 1980: This initial version of the Enforcement Policy described the Immediate Action Letter as "confirming a licensee's agreement to take certain actions to remove concerns about health and safety, safeguards, or the environment.

March 9, 1982: The Immediate Action Letter was renamed Confirmatory Action Letter in this revision.

##### **c. Demands for Information: Timeline**

February 18, 1992: This revision introduced the use of a Demand for Information as an additional administrative mechanism, normally issued prior to an order as a means of determining whether the order or other enforcement action should be issued.

##### **d. Letters of Reprimand: Timeline**

February 18, 1992: Although the 1987 and 1988 revisions to the Enforcement Policy had also mentioned the LOR as an appropriate sanction for issuance to NRC-licensed operators, the 1992 revision was the first to formally include the LOR as a separate administrative enforcement action. This change described the LOR as a letter to an

individual under Commission jurisdiction, identifying a significant deficiency in his or her performance of licensed activities.

*e. Use of Press Releases: Timeline*

March 9, 1982: This early revision of the Enforcement Policy specified the public availability of enforcement actions, inspection reports, and licensee responses. It also noted that press releases would normally be issued for orders and CPs, but not for NOVs.

February 18, 1992: This revision provided for press releases when a proposed CP is withdrawn or substantially mitigated.

*f. Enforcement Conferences: Timeline*

October 7, 1980: The initial version of the Enforcement Policy described the Enforcement Conference as an NRC meeting with licensee management to discuss technical safety issues, licensee compliance, proposed corrective measures, and the NRC's enforcement options.

March 9, 1982: This revision specified the use of Enforcement Conferences for all SL I, II, and III violations, and for SL IVs considered symptomatic of programmatic deficiencies.

March 8, 1984: A new section giving expanded guidance on Enforcement Conferences was added in this revision. Guidance was given on the circumstances for holding ECs and the information to be discussed. The policy noted that ECs would normally be closed to the public. Clarification was added on using ECs for SL IV violations.

*Appendix E: Enforcement Data***Table E-1: Escalated Enforcement Activities**

Reactor Activities <sup>1</sup>	1989	1990	1991	1992	1993	1994
Enforcement Conferences	119	94	91	82	107	82
SL I, II, or III NOVs Without CPs	25	29	12	28	20	30
NOVs With CPs	54	42	42	47	42	46
Orders Imposing CPs	12	13	1	1	4	1
Enforcement Orders	0	4	2	0	0	0
Hearings Requested	0	1	0	0	0	3

Materials Activities <sup>2</sup>	1989	1990	1991	1992	1993	1994
Enforcement Conferences	97	96	58	91	100	84
SL I, II, or III NOVs Without CPs	11	21	12	17	34	26
NOVs With CPs	52	57	42	47	74	53
Orders Imposing CPs	16	18	18	12	21	9
Enforcement Orders	10	12	12	11	17	32
Hearings Requested	3	3	1	0	5	6

<sup>1</sup>This includes actions involving Power Reactors, Research Reactors, Reactor Vendors, Licensed Operators, and Individual Actions associated with reactor matters.

<sup>2</sup>This includes materials licensees and Individual Actions associated with materials matters.

**Table E-2: Escalated Enforcement Actions  
Calendar Years 1989 - 1991**

	1989		1990		1991	
	CP <sup>3</sup>	NOV <sup>4</sup>	CP	NOV	CP	NOV
<b>Reactors:</b>						
Power Reactor	53	22	42	24	41	11
Research Reactor	1				1	
<b>Materials:</b>						
Gauge	8	1	9	2	7	2
Medical	28	6	32	11	16	4
Doctor	6	1	1	1		
Hospital	21	5	28	10	16	4
Pharmacy	1		3			
Radiography	8	1	12	3	9	2
Academic				1	5	1
Fuel Facility	1				1	1
Irradiator	1				1	
Material Distributor			2	2		
Mill	1					
Radiography Fabricator						
UF Conversion Facility						
Waste Disposal						
Well Logger	2	1			1	1
Other Materials Licensees	2	2	1	2	2	1
<b>Materials total:</b>	<b>52</b>	<b>11</b>	<b>56</b>	<b>21</b>	<b>42</b>	<b>12</b>

<sup>3</sup>"CP" designates NOVs issued with proposed CPs.

<sup>4</sup>"NOV" designates SL I, II, or III NOVs issued without CPs.



**Table E-2 (continued): Escalated Enforcement Actions  
Calendar Years 1992 - 1994**

	1992		1993		1994	
	CP <sup>5</sup>	NOV <sup>6</sup>	CP	NOV	CP	NOV
<b>Reactors:</b>						
Power Reactor	45	14	40	16	44	20
Research Reactor	2		2		2	1
<b>Materials:</b>						
Gauge	10	5	13	11	12	7
Medical	14	7	39	18	29	14
Doctor	2		6	1	3	1
Hospital	12	7	31	16	24	12
Pharmacy			2	1	2	1
Radiography	14	2	7	2	1	3
Academic	4		2		3	
Fuel Facility	2	1	5		1	
Irradiator						
Material Distributor						
Mill						
Radiography Fabricator				1		
UF Conversion Facility	1	2				
Waste Disposal						
Well Logger					1	
Other Materials Licensees	2		8	2	6	1
<b>Materials total:</b>	<b>47</b>	<b>17</b>	<b>74</b>	<b>34</b>	<b>53</b>	<b>25</b>

<sup>5</sup>"CP" designates NOVs issued with proposed CPs.

<sup>6</sup>"NOV" designates SL I, II, or III NOVs issued without CPs.



## *Appendix F: Background on Open Conferences*

### *1. FR Notice Announcing the Trial Program*

30762

Federal Register / Vol. 57, No. 133 / Friday, July 10, 1992 / Notices

**ADDRESSES:** Send comments to: The Secretary of the Commission, U.S. Nuclear Regulatory Commission, Washington, DC 20555. ATTN: Docketing and Service Branch.

Hand deliver comments to: One White Flint North, 11555 Rockville Pike, Rockville, MD between 7:45 a.m. to 4:15 p.m., Federal workdays.

Copies of comments may be examined at the NRC Public Document Room, 2120 L Street, NW, (Lower Level), Washington, DC

**FOR FURTHER INFORMATION CONTACT:** James Lieberman, Director, Office of Enforcement, U.S. Nuclear Regulatory Commission, Washington, DC 20555 (301-504-2741).

**SUPPLEMENTARY INFORMATION:**

**Background**

The NRC's current policy on enforcement conferences is addressed in Section V of the latest revision to the "General Statement of Policy and Procedure for Enforcement Actions," (Enforcement Policy) 10 CFR part 2, appendix C that was published on February 18, 1992 (57 FR 5791). The Enforcement Policy states that, "enforcement conferences will not normally be open to the public." However, the Commission has decided to implement a trial program to determine whether to maintain the current policy with regard to enforcement conferences or to adopt a new policy that would allow most enforcement conferences to be open to attendance by all members of the public.

**Policy Statement**

**Position**

The NRC is implementing a two-year trial program to allow public observation of selected enforcement conferences. The NRC will monitor the program and determine whether to establish a permanent policy for conducting open enforcement conferences based on an assessment of the following criteria:

(1) Whether the fact that the conference was open impacted the NRC's ability to conduct a meaningful conference and/or implement the NRC's enforcement program;

(2) Whether the open conference impacted the licensee's participation in the conference;

(3) Whether the NRC expended a significant amount of resources in making the conference public; and

(4) The extent of public interest in opening the enforcement conference.

**Two-Year Trial Program for Conducting Open Enforcement Conferences; Policy Statement**

**AGENCY:** Nuclear Regulatory Commission.

**ACTION:** Policy statement.

**SUMMARY:** The Nuclear Regulatory Commission (NRC) is issuing this policy statement on the implementation of a two-year trial program to allow selected enforcement conferences to be open to attendance by all members of the general public. This policy statement describes the two-year trial program and informs the public of how to get information on upcoming open enforcement conferences.

**DATES:** This trial program is effective on July 10, 1992, while comments on the program are being received. Submit comments on or before the completion of the trial program scheduled for July 11, 1992. Comments received after this date will be considered if it is practical to do so, but the Commission is able to assure consideration only for comments received on or before this date.

### I. Criteria For Selecting Open Enforcement Conferences

Enforcement conferences will not be open to the public if the enforcement action being contemplated—

- (1) Would be taken against an individual, or if the action, though not taken against an individual, turns on whether an individual has committed wrongdoing;
- (2) Involves significant personnel failures where the NRC has requested that the individual(s) involved be present at the conference;
- (3) Is based on the findings of an NRC Office of Investigations (OI) report; or
- (4) Involves safeguards information, Privacy Act information, or other information which could be considered proprietary.

Enforcement conferences involving medical misadministrations or overexposures will be open assuming the conference can be conducted without disclosing the exposed individual's name. In addition, enforcement conferences will not be open to the public if the conference will be conducted by telephone or the conference will be conducted at a relatively small licensee's facility. Finally, with the approval of the Executive Director for Operations, enforcement conferences will not be open to the public in special cases where good cause has been shown after balancing the benefit of public observation against the potential impact on the agency's enforcement action in a particular case.

The NRC will strive to conduct open enforcement conferences during the two-year trial program in accordance with the following three goals:

- (1) Approximately 25 percent of all eligible enforcement conferences conducted by the NRC will be open for public observation;
- (2) At least one open enforcement conference will be conducted in each of the regional offices; and
- (3) Open enforcement conferences will be conducted with a variety of the types of licensees.

To avoid potential bias in the selection process and to attempt to meet the three goals stated above, every fourth eligible enforcement conference involving one of three categories of licensees will normally be open to the public during the trial program. However, in cases where there is an ongoing adjudicatory proceeding with one or more intervenors, enforcement conferences involving issues related to the subject matter of the ongoing adjudication may also be opened. For the purposes of this trial program, the

three categories of licensees will be commercial operating reactors, hospitals, and other licensees, which will consist of the remaining types of licensees.

### II. Announcing Open Enforcement Conferences

As soon as it is determined that an enforcement conference will be open to public observation, the NRC will orally notify the licensee that the enforcement conference will be open to public observation as part of the agency's trial program and send the licensee a copy of this Federal Register notice that outlines the program. Licensees will be asked to estimate the number of participants it will bring to the enforcement conference so that the NRC can schedule an appropriately sized conference room. The NRC will also notify appropriate State liaison officers that an enforcement conference has been scheduled and that it is open to public observation.

The NRC intends to announce open enforcement conferences to the public normally at least 10 working days in advance of the enforcement conference through the following mechanisms:

- (1) Notices posted in the Public Document Room;
- (2) Toll-free telephone messages; and
- (3) Toll-free electronic bulletin board messages.

Pending establishment of the toll-free message systems, the public may call (301) 492-4732 to obtain a recording of upcoming open enforcement conferences. The NRC will issue another Federal Register notice after the toll-free message systems are established.

To assist the NRC in making appropriate arrangements to support public observation of enforcement conferences, individuals interested in attending a particular enforcement conference should notify the individual identified in the meeting notice announcing the open enforcement conference no later than five business days prior to the enforcement conference.

### III. Conduct of Open Enforcement Conferences

In accordance with current practice, enforcement conferences will continue to normally be held at the NRC regional offices. Members of the public will be allowed access to the NRC regional offices to attend open enforcement conferences in accordance with the "Standard Operating Procedures For Providing Security Support For NRC Hearings And Meetings" published November 1, 1991 (56 FR 58251). These procedures provide that visitors may be

subject to personnel screening, that signs, banners, posters, etc., not larger than 18" be permitted, and that disruptive persons may be removed.

Each regional office will continue to conduct the enforcement conference proceedings in accordance with regional practice. The enforcement conference will continue to be a meeting between the NRC and the licensee. While the enforcement conference is open for public observation, it is not open for public participation.

Persons attending open enforcement conferences are reminded that (1) the apparent violations discussed at open enforcement conferences are subject to further review and may be subject to change prior to any resulting enforcement action and (2) the statements of views or expressions of opinion made by NRC employees at open enforcement conferences or the lack thereof, are not intended to represent final determinations or beliefs.

In addition to providing comments on the agency's trial program in accordance with the guidance in this notice, persons attending open enforcement conferences will be provided an opportunity to submit written comments anonymously to the regional office. These comments will subsequently be forwarded to the Director of the Office of Enforcement for review and consideration.

Dated at Rockville, MD, this 7th day of July 1992.

For the Nuclear Regulatory Commission,  
Samuel J. Chilk,  
Secretary of the Commission.  
[FR Doc. 92-18233 Filed 7-9-92; 8:45 a.m.]  
BILLING CODE 7590-01-01

2. *Statistics on Enforcement Conferences***Table F-1: Actions Resulting From Enforcement Conferences***(In Number of Reactor Cases)*

	1990	1991	1992	1993	1994
Enforcement Conferences	89	86	78	97 <sup>1</sup>	71
Civil Penalties	36 (40%)	43 (50%)	37 (47%)	45 (46%)	32 (45%)
Notices of Violation	15 (17%)	13 (15%)	8 (10%)	23 (24%)	10 (14%)
Non-Escalated Actions	30 (34%)	23 (27%)	30 (38%)	21 (22%)	26 (37%)
No Resulting Enforcement Actions	8 (9%)	7 (8%)	3 (4%)	7 (7%)	3 (4%)

- ◆ Notices of Violation category includes all SL I, II, and III violations.
- ◆ Non-Escalated Actions category includes all SL IV and V violations and actions not assigned a severity level.
- ◆ No Resulting Enforcement Actions category includes all letters, and includes all cases where no action was taken against the licensee.

---

<sup>1</sup>This data includes one case for which an enforcement conference was held and an enforcement decision has not yet been made.

**Table F-2: Actions Resulting From Enforcement Conferences***(In Number of Materials Cases)*

	1990	1991	1992	1993	1994
Enforcement Conferences	96	58	91	100	84
Civil Penalties	56 (58%)	37 (64%)	52 (57%)	65 (65%)	41 (49%)
Notices of Violation	21 (22%)	12 (21%)	16 (18%)	19 (19%)	22 (26%)
Non-Escalated Actions	15 (16%)	9 (16%)	20 (22%)	16 (16%)	13 (15%)
No Resulting Enforcement Actions	4 (4%)	0 (0%)	3 (3%)	0 (0%)	8 <sup>2</sup> (10%)

- ◆ The percentage is of the total enforcement conferences in a year.
- ◆ Notices of Violation category includes all SL I, II, and III violations without CPs.
- ◆ Non-Escalated Enforcement Actions category includes all SL IV and V violations and actions not assigned a severity level.
- ◆ No Resulting Enforcement Actions category includes all letters, and includes all cases where no action was taken against the licensee.

<sup>2</sup>This data may include some cases for which appropriate enforcement actions have not been determined.

**Table F-3: Open Enforcement Conference Statistics***July 10, 1992 - February 28, 1995*

Enforcement Conferences <sup>3</sup>	Reactor Licensees	Hospital Licensees	Other Licensees	Total
Open	42	20	25	87
Closed	119	54	64	237
Total	161	74	89	324

Conferences Without Public Attendance	50 (57%)
Conferences With Public Attendance <sup>4</sup>	37 (43%)
Range of Public Attendance	1 TO 20
Average Public Attendance <sup>5</sup>	3.7
Conferences With 1 to 3 Observers	29 (78%)
Conferences With More Than 3 Observers	8 (22%)

<sup>3</sup>Does not include enforcement conferences exempt from trial program (e.g., those involving an individual, an OI report, or safeguards or privacy information).

<sup>4</sup>Public attendance includes members of the media, State government representatives, and interested citizens.

<sup>5</sup>Based on conferences that had public attendance.



### *Appendix G: Examples of Applying the Identification Assessment Factor*

As noted in Section II.D.6 of this report, the question to be asked in applying this factor is who should get credit for identifying the problem. Generally, if the licensee identifies a problem before an event occurs or before the NRC identifies it, the licensee should normally get credit for the identification (even if missed opportunities existed, including the failure of past corrective action for similar violations). However, if the violation is identified as the result of an event associated with normal operations, in contrast to an event associated with an assessment activity such as a surveillance test, any missed opportunities should be considered. If the NRC identifies the violation, it is appropriate to consider whether the licensee should have identified the violation. The actual application of the factor will be a function of the circumstances of the case, the issues associated with identification, and the regulatory message warranted by the facts of the case. Identification also presumes recognizing that some corrective action is required.

The following examples are intended to provide the reader with some general guidance on how the Review Team expects the identification factor to be applied. Recognizing that application of this factor will require applying judgment to the particular set of facts and circumstances in each case, the following guidance should not be viewed as controlling or exhaustive.

#### *A. Situations In Which the Licensee Should Be Given Credit:*

1. Violations involving the failure to install required parts on a pump, where the failure results in high vibration readings before the pump fails.
2. Violations identified as a result of surveillances or tests, when a parameter check is required by the procedure and limits or ranges do not meet regulatory requirements.
3. Discovery of a valve or controller in the wrong position while performing a step in a surveillance procedure.
4. Discovery of inoperable equipment during surveillance testing performed to determine the operability of that equipment. If as a result of the surveillance testing, an event occurs because of other equipment (i.e., equipment not being tested) failing, missed opportunities should be considered when evaluating identification for the failure of the "other" equipment.
5. Violations identified during a surveillance test where an evolution or process that is being tested does not proceed as expected. For example: (1) a liquid spill due to a mispositioned valve; (2) safety-related equipment failing to start because of failure to

- include the position of a controller in a surveillance procedure; or (3) unanticipated equipment starts or work proceeds on an energized circuit because of a previous failure to tagout equipment.
6. Disclosure of a fitness-for-duty violation during routine testing.
  7. Identification of a violation as a result of the licensee followup of safety concerns raised by an employee of the licensee.
  8. Violations identified in audit findings, deficiency reports, or contractor reviews, in which the condition adverse to quality was not corrected in a timely manner, but was later disclosed by a licensee review before an event occurred.
  9. Violations identified by a contractor doing audits provided action was taken to correct the matter. For example, the licensee would *not* get credit for its contractor identifying a violation if the licensee took no action to address the violation and NRC later identified the violation.
  10. Violations identified as the result of procedurally required checks of a medical treatment plan before treatment occurs, or as the result of daily checks of radiography equipment before the equipment is used.
  11. Cases in which, in response to an event, a licensee investigation identifies violations that were not involved in or did not contribute to the event.
  12. Cases in which the licensee initiates a review of data anomalies or unusual circumstances not involving an event and, as a result, identifies violations. For example: (1) deliberate contamination of clothing discovered due to a licensee-initiated health physics review of a plant condition; (2) falsified information on an employee application discovered due to follow-up of discrepancies by the licensee; (3) discovery of a design deficiency due to special or complex evaluations of unusual equipment interactions; or (4) discovery of a fitness-for-duty violation during testing, where observation of an employee resulted in licensee initiation of the testing.
  13. Violations identified as the result of a licensee's review of generic communications, reports from other sites, reports generated by outside groups, reports generated by industry groups, reports contracted by the licensee, NRC Information Notices, generic letters, or follow-up from general discussions with an NRC inspector as a result of his or her knowledge gained from other plants or NRC activities.

14. The identification of failures to follow procedures or deficient procedures by a licensee employee, where the failure would not have been disclosed by subsequent procedural checks prior to an event occurring.
15. If the NRC finds a violation prior to the licensee's identification of it, but the licensee was aggressively pursuing the same issue as the result of an NRC Information Notice and likely would have found it within a reasonable time, the licensee should get credit for its identification activities.

***B. Situations In Which Missed Opportunities Should Be Considered Before Giving the Licensee Credit for Identification:***

1. Violations identified as the result of an event that was readily obvious by human observation or mechanical instrumentation such as a reactor trip, or leak spills, or annunciator alarms.
2. As the result of a reactor trip, the licensee identifies deficient procedures that led to a failure to reset instrument controls.
3. As the result of a dropped fuel assembly, the licensee identifies the failure to confirm that a fuel assembly grappling device had closed.
4. As the result of a lost or damaged gauge, the licensee identifies a failure to maintain constant control over a gauge containing byproduct material.
5. Discovery of an overexposure documented in a dosimetry report.
6. Licensee identifying the improper shipment or packaging of radioactive material found by the receiving company.
7. Licensee identifying the loss of control of material after being informed by a member of the public that material has been found in the environment.
8. Receipt of records from the FBI indicating that a person who has been granted unescorted access had a criminal history of which the licensee was not aware, although the information was available in the licensee's records.
9. As a result of an event or NRC questions, the licensee identifies violations that it should have found earlier if it had been responsive to previous audits findings,

deficiency reports or contractor reviews, where conditions adverse to quality were not corrected in a timely manner.

10. Violations that caused or contributed to an event, identified as part of a follow-up to the event.
11. Violations identified as part of determining the root causes for a radiation injury to a patient.
12. Cases in which the inappropriate location of sources results in a misadministration being disclosed when the source is removed.
13. Cases in which an overexposure is identified after reading personal dosimetry or data documented in dosimetry reports following an event where, due to the event, the potential for an overexposure exists.
14. Cases in which an event occurs as a result of an evolution or process during operations that do not proceed as expected and violations are subsequently identified. For example, (1) a liquid spill due to a mispositioned valve; (2) indications in the control room that safety-related equipment fails to start because of failure to include the position of a controller in an operations procedure; or (3) unanticipated equipment starts or work proceeds on an energized circuit because of the failure to tagout equipment.

### ***C. NRC-Identified Situations***

1. Cases in which a licensee does not appear to have been pursuing a matter on its own but, due to concerns raised by the NRC, identifies (1) violations related to equipment failures when the NRC has questioned operability of the equipment; or (2) violations of reporting requirements found when the NRC requested information on the event.
2. Violations related to an event would be considered NRC-identified if the violation is subsequently discovered by the NRC during event follow-up, where the licensee has failed to initiate reviews or investigations that would have reasonably identified the violation. For example, a misadministration may have occurred that the licensee attributes to a failure to follow procedure, and does not pursue the matter further. If the NRC finds that an underlying root cause violation exists (e.g., a training violation), but the licensee has not pursued it, that violation would not be considered licensee-identified.

<p>NRC FORM 335 (2-89) NRCM 1102, 3201, 3202</p> <p style="text-align: center;">U.S. NUCLEAR REGULATORY COMMISSION</p> <p style="text-align: center;"><b>BIBLIOGRAPHIC DATA SHEET</b></p> <p style="text-align: center;"><i>(See instructions on the reverse)</i></p>	<p>1. REPORT NUMBER (Assigned by NRC. Add Vol., Supp., Rev., and Addendum Numbers, if any.)</p>				
<p>2. TITLE AND SUBTITLE</p> <p style="text-align: center;">Assessment of the NRC Enforcement Program</p>	<p>NUREG-1525</p> <p>3. DATE REPORT PUBLISHED</p> <table border="1" style="width: 100%;"> <tr> <td style="width: 50%;">MONTH</td> <td style="width: 50%;">YEAR</td> </tr> <tr> <td style="text-align: center;">April</td> <td style="text-align: center;">1995</td> </tr> </table> <p>4. FIN OR GRANT NUMBER</p>	MONTH	YEAR	April	1995
MONTH	YEAR				
April	1995				
<p>5. AUTHOR(S)</p> <p>James Lieberman Laban Coblentz</p>	<p>6. TYPE OF REPORT</p> <p style="text-align: center;">Technical</p> <p>7. PERIOD COVERED (Inclusive Dates)</p>				
<p>8. PERFORMING ORGANIZATION - NAME AND ADDRESS (If NRC, provide Division, Office or Region, U.S. Nuclear Regulatory Commission, and mailing address; if contractor, provide name and mailing address.)</p> <p style="text-align: center;">U.S. Nuclear Regulatory Commission Washington, D.C. 20555-0001</p>					
<p>9. SPONSORING ORGANIZATION - NAME AND ADDRESS (If NRC, type "Same as above"; if contractor, provide NRC Division, Office or Region, U.S. Nuclear Regulatory Commission, and mailing address.)</p> <p style="text-align: center;">Same as Above</p>					
<p>10. SUPPLEMENTARY NOTES</p>					
<p>11. ABSTRACT (200 words or less)</p> <p>On May 13, 1994, the Nuclear Regulatory Commission's (NRC's) Executive Director for Operations established a Review Team to Assess the NRC Enforcement Program. The team evaluated the current system, and solicited comments from various NRC Offices, other Federal agencies, members of industry, and the public. This report presents the team's assessment. The report summarizes current processes and suggests certain changes. It proposes: (1) increased clarity, focus, and simplicity in the enforcement program; (2) retention of four severity levels of violations, with a clear focus on safety; (3) holding enforcement conferences only when needed, clarifying their status as predecisional, and making open conferences the norm; (4) a streamlined civil penalty assessment process, with fewer decisional points and limited outcomes, and the use of discretion where appropriate; and (5) implementation changes to increase efficiency. Recommendations are given in each area.</p>					
<p>12. KEY WORDS/DESCRIPTORS (List words or phrases that will assist researchers in locating the report.)</p> <p>Enforcement, Civil Penalties, Violation, Enforcement Conference, Enforcement Policy</p>	<p>13. AVAILABILITY STATEMENT</p> <p style="text-align: center;">Unlimited</p> <p>14. SECURITY CLASSIFICATION</p> <p style="text-align: center;">(This Page)</p> <hr/> <p style="text-align: center;">(This Report)</p> <p style="text-align: center;">Unclassified</p> <p>15. NUMBER OF PAGES</p> <hr/> <p>16. PRICE</p>				



**Federal Recycling Program**



**UNITED STATES**  
**NUCLEAR REGULATORY COMMISSION**  
WASHINGTON, D.C. 20555-0001

---

**OFFICIAL BUSINESS**  
**PENALTY FOR PRIVATE USE, \$300**

**SPECIAL FOURTH-CLASS RATE**  
**POSTAGE AND FEES PAID**  
**USNRC**  
**PERMIT NO. G-67**