

### 9.3 Process Auxiliaries

The information in this section of the reference ABWR DCD, including all subsections, tables, and figures, is incorporated by reference with the following departures and supplements.

STD DEP Admin

STD DEP 9.3-2

#### 9.3.2 Process and Post Accident Sampling System

STD DEP Admin

##### 9.3.2.1.1 Safety Design Bases

- (4) *The sampling panels are designed to minimize contamination and radiation at the sample stations. Appropriate shielding, where required, and area radiation monitors minimize radiation effects. Radiation exposure to the individual shall be limited as given in ITAAC ~~3-7~~ 3.2.*

#### 9.3.3 Non-Radioactive Drainage System

##### 9.3.3.2 Non-Radioactive Drains (Interface Requirements)

The following site-specific supplement addresses COL License Information Item 9.15.

The design of the continuation of the non-radioactive drain system from the ABWR Standard Plant Buildings to the site discharge outfall is provided in Figure 9.3-12 and is discussed in this subsection.

##### 9.3.3.2.3 System Description

The conceptual design information in this subsection of the reference ABWR DCD is replaced with the following site-specific supplement.

The non-radioactive drain system collects waste water from plant buildings (Reactor, Turbine, Control, Service, and other buildings). A system composed of collection piping, curbs, and pumps is provided. Non-radioactive waste water from the Turbine Building, Reactor Building, hot machine shop and the Control Building is routed to a dedicated oil/water separator where oil and settled solids are removed for off-site disposal. The non-oily, non-radioactive effluent is sent to dual settling basins. Non-radioactive waste water from the Service Building and other buildings is sent directly to the dual settling basins. Means are provided to perform any required tests or analyses required by the discharge permit. The non-radioactive liquid effluent is discharged to the Main Cooling Reservoir through permitted outfall(s). If radioactivity levels exceed the limits for discharge, the flow from the non-radioactive drains has the capability to be diverted to the radioactive effluent portion of the radwaste system. Normally, if low levels of radioactivity are detected, it is quantified and discharged via the normal outfall. Higher levels of radioactivity may require a permitted "batch"

discharge via the radwaste effluent radiation monitor. The non-radioactive drainage system is illustrated in Figure 9.3-12.

### 9.3.7 Service Air System

The information in this section of the reference ABWR DCD, including all subsections, tables and figures, is incorporated by reference with the following departure

#### 9.3.7.2 System Description

STD DEP 9.3-2

*The SAS provides compressed air for tank sparging, filter/demineralizer backwashing, air-operated tools and other services requiring air of lower quality than that provided by the IAS. ~~Breathing air requirements are provided by the SAS.~~ The Breathing Air System (BAS) is discussed in Subsection 9.3.7.6.*

#### Service Air

Pressure (design)	0.69 0.87 MPa
Dewpoint (°C)	no requirement

### 9.3.7.6 Breathing Air System

#### 9.3.7.6.1 Design Bases

##### 9.3.7.6.1.1 Safety Design Bases

The BAS is classified as non-safety related with the exception of the primary containment isolation function.

The primary containment penetration of the BAS meets Seismic Category I requirements and is equipped with a locked closed manual isolation valve outside and a check valve inside containment (GDC 56).

##### 9.3.7.6.1.2 Power Generation Design Bases

The functions of BAS are to provide the following:

- (1) Supply low pressure breathable air for use by workers during periods when actual or potential airborne contamination exists.
- (2) A means for charging high pressure self-contained breathing apparatus.

#### 9.3.7.6.2 System Description

The BAS is designed to provide compressed air of suitable breathing quality for nonsafety-related functions.

The BAS provides a continuous supply of low pressure breathing air for protection against airborne contamination while performing maintenance inspection and cleaning

work. The BAS also provides a means for charging high pressure self-contained breathing apparatus.

The BAS has two air compressors, each sized to provide 50% of the peak air consumption. The compressors are of the oil-less, breathing air type.

The BAS also has one compressor sized to charge high pressure self-contained breathing apparatus.

The BAS flow diagram is shown in Figure 9.3-10.

The BAS process quality requirements are listed below.

#### **Breathing Air**

<u>Pressure (design of BAS)</u>	<u>689 kPaG</u>
<u>Pressure (design of self-contained breathing apparatus charging)</u>	<u>17.23 MPaG</u>
<u>ANSI Compressed Gas Association (CGA) 7.1-1997, "Commodity Specification for Air"</u>	<u>Air Quality Grade D</u>

The BAS is designed to meet applicable regulatory requirements regarding limiting personnel exposure to airborne radioactivity and maintaining breathing air quality, including those defined by the NRC in 10 CFR 20 and Occupational Safety and Health Act Requirements (OSHA) in 29 CFR 1910. In addition, the BAS design is consistent with Regulatory Guide 8.15.

The BAS containment and penetration and associated isolation valves are designed to Seismic Category I, ASME Code, Section III, Class 2, Quality Group B and Quality Assurance B requirements.

The air compressors are operated during normal operation.

Outside primary containment a manually-operated valve is kept closed and locked during normal plant operation. During refueling, the valve is opened to provide air inside the containment. A check valve is provided inside the containment. This arrangement meets GDC 56, Option (2).

#### **9.3.7.6.3 Safety Evaluation**

The availability of breathing air is not required to assure any of the following:

- (1) Integrity of the reactor coolant pressure boundary.
- (2) Capability to shut down the reactor and maintain it in a safe shutdown condition.

- (3) Ability to prevent or mitigate the consequences of accidents which can result in potential offsite exposures comparable to the guideline exposures of 10 CFR 100.

However, the containment penetration and isolation valves associated with the breathing air system are relied upon to maintain the integrity of the containment pressure boundary as discussed in Section 9.3.7.6.1.1. The operability of this containment pressure boundary function is necessary to assure (3) above.

#### **9.3.7.6.4 Inspection and Testing Requirements**

The BAS is proved operable by its use during normal plant operation. Portions of the system normally closed to airflow can be tested to ensure system operability and integrity.

#### **9.3.7.6.5 Instrumentation Application**

Instrumentation for the BAS is primarily local, consisting of pressure, differential pressure and temperature indication and/or control. Pressure transmitters and pressure switches provide control room pressure indications and alarms. The system is maintained at constant pressure, with local pressure reduction provided as required.

### **9.3.12 COL License Information**

#### **9.3.12.4 Radioactive Drain Transfer System**

The following standard supplement addresses COL License Information Item 9.15.

Equipment and floor drain P & I Ds are provided in Figure 9.3-11, Sheets 1 through 22. See Subsection 9.3.8.1.1.

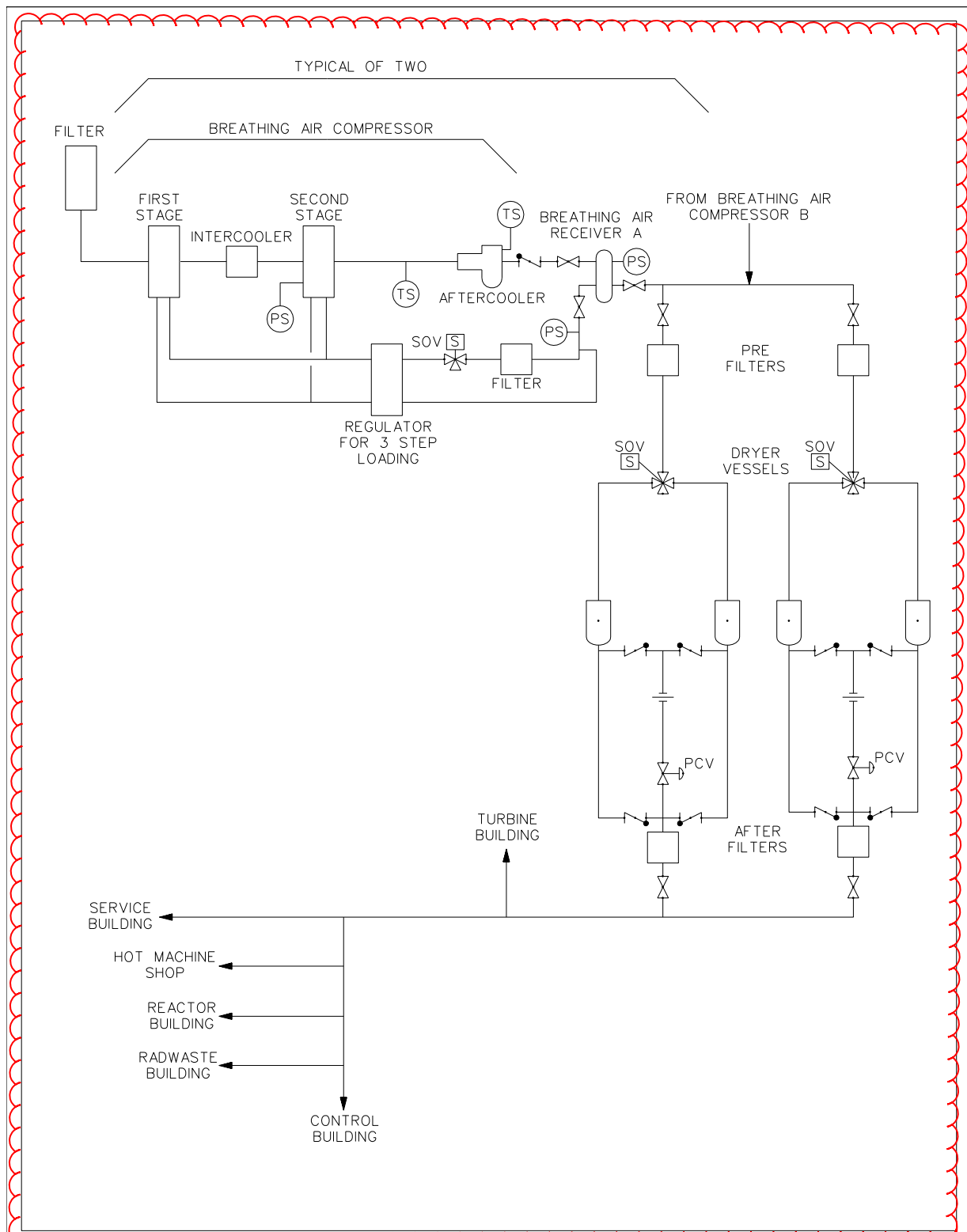

Figure 9.3-10 Breathing Air System Flow Diagram

The following figures are located in Chapter 21:

- Figure 9.3-11 Radioactive Drain Transfer System P&ID (Sheets 1-22)

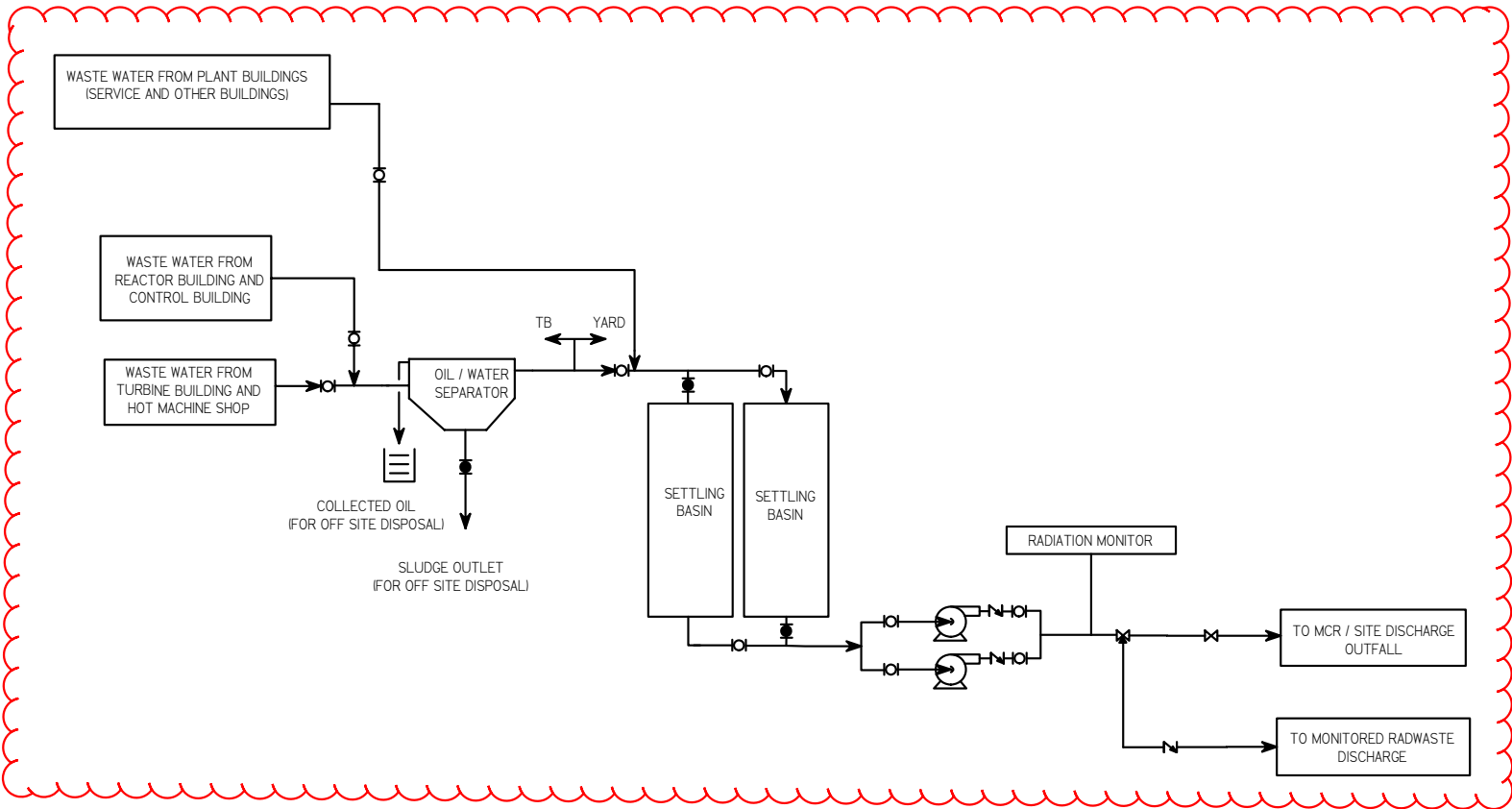

Figure 9.3-12 Non-Radioactive Drainage System

