

ENCLOSURE 4 to TXX-07106

**WCAP-16827-NP
Comanche Peak Units 1 and 2 Spent Fuel Pool
Criticality Safety Analysis
(Non-proprietary)**

Westinghouse Non-Proprietary Class 3

WCAP-16827-NP
Revision 0

July 2007

Comanche Peak Units 1 and 2 Spent Fuel Pool Criticality Safety Analysis



WCAP-16827-NP

**Comanche Peak Units 1 and 2
Spent Fuel Pool Criticality Safety Analysis**

July 2007

Contributors:

**Michael G. Anness
Justin B. Clarity
Vefa N. Kucukboyaci
William J. Marshall**

Approved:

**Bryan M. Weitzel, Manager
Core Analysis A**

Electronically approved documents are authenticated in the Electronic Document Management System

Westinghouse Electric Company LLC
Nuclear Fuel
4350 Northern Pike
Monroeville, PA 15146

©2007 Westinghouse Electric Company LLC
All Rights Reserved

Table of Contents

<u>Section</u>	<u>Title</u>	<u>Page</u>
1.0	Objective	1
1.1	Design Criteria	2
2.0	Methodology	3
2.1	Nuclear Design Software	3
2.1.1	The SCALE Code	3
2.1.2	The PHOENIX-P Code.....	6
2.2	Axial Burnup Distribution Modeling	7
2.3	Decay Time Credit Methodology.....	9
2.4	Methodology Assumptions	10
3.0	Design Input	15
3.1	Customer Design Input.....	15
3.2	Comanche Peak Units 1 and 2 Spent Fuel Pool Region II Layout Description.....	15
3.3	Comanche Peak Units 1 and 2 Region II Storage Rack Cell Description.....	15
3.4	RackSaver Poison Insert Description.....	15
3.5	Rod Cluster Control Assembly Poison Insert Description.....	16
3.6	Oversize Inspection Cell Description.....	16
3.7	Fuel Assembly Design Parameters.....	16
3.8	Core Operating Conditions.....	17
4.0	Analysis.....	33
4.1	Spent Fuel Pool Infinite Array KENO Models	33
4.1.1	“4-out-of-4” and “4-out-of-4 with Axial Blankets” Storage Configuration	34
4.1.2	“4-out-of-4 with 1 RCCA” Storage Configuration.....	34
4.1.3	“4-out-of-4 with 2 RCCAs” Storage Configuration	34
4.1.4	“4-out-of-4 with 2 RackSavers and Axial Blankets” Storage Configuration Model.....	34
4.1.5	“4-out-of-4 with 3 RackSavers and Axial Blankets” Storage Configuration	34
4.1.6	“3-out-of-4” and “3-out-of-4 with Axial Blankets” Storage Configuration	35
4.1.7	“2-out-of-4” Storage Configuration.....	35

4.1.8	Oversize Inspection Cell KENO Model	35
4.2	Biases and Uncertainties Calculations	35
4.3	Determination of Minimum Burnup Requirements at No Soluble Boron Conditions... 37	
4.3.1	“4-out-of-4” Storage Configuration.....	37
4.3.2	“4-out-of-4 with Axial Blankets” Storage Configuration.....	38
4.3.3	“4-out-of-4 with 1 RCCA” Storage Configuration.....	39
4.3.4	“4-out-of-4 with 2 RCCAs” Storage Configuration	39
4.3.5	“4-out-of-4 with 2 RackSavers and Axial Blankets” Storage Configuration Model.....	40
4.3.6	“4-out-of-4 with 3 RackSavers and Axial Blankets” Storage Configuration	41
4.3.7	“3-out-of-4” Storage Configuration.....	42
4.3.8	“3-out-of-4 with Axial Blankets” Storage Configuration.....	42
4.3.9	“2-out-of-4” Storage Configuration.....	43
4.4	“Oversize Inspection Cell” Storage Configurations.....	44
4.5	Entire Spent Fuel Pool KENO Model.....	44
4.5.1	Storage Configuration Interface Requirements	45
4.6	Soluble Boron Credit.....	46
4.6.1	Soluble Boron Requirement to Maintain k_{eff} Less Than or Equal to 0.95.....	46
4.6.2	Soluble Boron Requirement for Burnup Credit Reactivity Uncertainties	46
4.6.3	Soluble Boron Required to Mitigate Postulated Accident Effects.....	47
4.6.4	Total Soluble Boron Requirement	48
5.0	Summary of Results	89
5.1	Allowable Fuel Assembly Designs	89
5.2	Allowable Comanche Peak Units 1 and 2 Spent Fuel Pool Storage Configurations	89
5.2.1	“4-out-of-4” Storage Configuration.....	89
5.2.2	“4-out-of-4 with Axial Blankets” Storage Configuration.....	89
5.2.3	“4-out-of-4 with 1 RCCA” Storage Configuration.....	89
5.2.4	“4-out-of-4 with 2 RCCAs” Storage Configuration	90
5.2.5	“4-out-of-4 with 2 RackSavers and Axial Blankets” Storage Configuration	90
5.2.6	“4-out-of-4 with 3 RackSavers and Axial Blankets” Storage Configuration	90
5.2.7	“3-out-of-4” Storage Configuration.....	90

5.2.8 “3-out-of-4 with Axial Blankets” Storage Configuration..... 90

5.2.9 “2-out-of-4” Storage Configuration..... 91

5.3 Oversize Inspection Cell Storage 91

5.4 Interface Requirements in the Spent Fuel Pool..... 91

5.5 Total Soluble Boron Requirement..... 91

6.0 References 117

List of Tables

<u>Table</u>	<u>Title</u>	<u>Page</u>
Table 2-1.	Standard Material Compositions Employed in the Comanche Peak Units 1 and 2 Spent Fuel Pool Criticality Analysis	11
Table 2-2.	Calculational Results for Cores X Through XXI of the B&W Close Proximity Experiments.....	12
Table 2-3.	Calculational Results for Selected Experimental PNL Lattices, Fuel Shipping and Storage Configurations.....	13
Table 3-1.	Comanche Peak Units 1 and 2 Rack Storage Cell Description	18
Table 3-2.	RackSaver Poison Insert Description	19
Table 3-3.	RCCA Poison Insert Description.....	20
Table 3-4.	Region II Oversize Inspection Cell Description.....	21
Table 3-5.	Fuel Assembly Design Data	22
Table 3-6.	Relative Power and Moderator Temperatures for the [] ^{a,c} Distributed Burnup Models	23
Table 3-7.	Relative Power and Moderator Temperatures for the [] ^{a,c} Distributed Burnup Models	24
Table 4-1.	“4-out-of-4” and “4-out-of-4 with Axial Blankets” Storage Configuration Biases and Uncertainties k_{eff} Results	49
Table 4-2.	“4-out-of-4 with 1 RCCA” Storage Configuration Biases and Uncertainties k_{eff} Results	50
Table 4-3.	“4-out-of-4 with 2 RCCAs” Storage Configuration Biases and Uncertainties k_{eff} Results	51
Table 4-4.	“4-out-of-4 with 2 RackSavers and Axial Blankets” Storage Configuration Biases and Uncertainties k_{eff} Results	52
Table 4-5.	“4-out-of-4 with 3 RackSavers and Axial Blankets” Storage Configuration Biases and Uncertainties k_{eff} Results	53
Table 4-6.	“3-out-of-4” and “3-out-of-4 with Axial Blankets” Storage Configuration Biases and Uncertainties k_{eff} Results	54
Table 4-7.	“2-out-of-4” Storage Configuration Biases and Uncertainties k_{eff} Results	55
Table 4-8.	“4-out-of-4” Storage Configuration Total Biases and Uncertainties Results.....	56
Table 4-9.	“4-out-of-4 with Axial Blankets” Storage Configuration Total Biases and Uncertainties Results.....	57

Table 4-10. “4-out-of-4 with 1 RCCA” Storage Configuration Total Biases and Uncertainties Results	58
Table 4-11. “4-out-of-4 with 2 RCCAs” Storage Configuration Total Biases and Uncertainties Results	59
Table 4-12. “4-out-of-4 with 2 RackSavers and Axial Blankets” Storage Configuration Total Biases and Uncertainties Results.....	60
Table 4-13. “4-out-of-4 with 3 RackSavers and Axial Blankets” Storage Configuration Total Biases and Uncertainties Results.....	61
Table 4-14. “3-out-of-4” Storage Configuration Total Biases and Uncertainties Results.....	62
Table 4-15. “3-out-of-4 with Axial Blankets” Storage Configuration Total Biases and Uncertainties Results	63
Table 4-16. “2-out-of-4” Storage Configuration Total Biases and Uncertainties Results.....	64
Table 4-17. Limiting k_{eff} Values versus Initial ^{235}U Enrichment, Assembly Burnup and Decay Time for the “4-out-of-4” Storage Configuration	65
Table 4-18. Limiting k_{eff} Values versus Initial ^{235}U Enrichment, Assembly Burnup and Decay Time for the “4-out-of-4 with Axial Blankets” Storage Configuration	66
Table 4-19. Limiting k_{eff} Values versus Initial ^{235}U Enrichment and Assembly-Average Burnup for the “4-out-of-4 with 1 RCCA” Storage Configuration.....	67
Table 4-20. Limiting k_{eff} Values versus Initial ^{235}U Enrichment and Assembly-Average Burnup for the “4-out-of-4 with 2 RCCAs” Storage Configuration	68
Table 4-21. Limiting k_{eff} Values versus Initial ^{235}U Enrichment and Assembly-Average Burnup for the “4-out-of-4 with 2 RackSavers and Axial Blankets” Storage Configuration	69
Table 4-22. Limiting k_{eff} Values versus Initial ^{235}U Enrichment and Assembly-Average Burnup for the “4-out-of-4 with 3 RackSavers and Axial Blankets” Storage Configuration	70
Table 4-23. Limiting k_{eff} Values versus Initial ^{235}U Enrichment, Assembly Burnup and Decay Time for the “3-out-of-4” Storage Configuration	71
Table 4-24. Limiting k_{eff} Values versus Initial ^{235}U Enrichment, Assembly Burnup and Decay Time for the “3-out-of-4 with Axial Blankets” Storage Configuration	72
Table 4-25. Limiting k_{eff} Values versus Initial ^{235}U Enrichment and Assembly-Average Burnup for the “2-out-of-4” Storage Configuration.....	73
Table 4-26. Oversize Inspection Cell k_{eff} Results.....	74
Table 4-27. Entire Spent Fuel Pool k_{eff} Results for the Interface Configurations	75
Table 4-28. k_{eff} Values as a Function of Soluble Boron Concentration for the Spent Fuel Pool .	77
Table 4-29. Summary of Burnup Reactivity Uncertainties for the Storage Configurations.....	78
Table 5-1. Minimum Required Assembly-Average Burnup versus Initial ^{235}U Enrichment and Decay Time for the “4-out-of-4” Storage Configuration	92

Table 5-2. Minimum Required Assembly-Average Burnup versus Initial ²³⁵U Enrichment and Decay Time for the “4-out-of-4 with Axial Blankets” Storage Configuration 93

Table 5-3. Minimum Required Assembly-Average Burnup versus Initial ²³⁵U Enrichment and Decay Time for the “4-out-of-4 with 1 RCCA” Storage Configuration 94

Table 5-4. Minimum Required Assembly-Average Burnup versus Initial ²³⁵U Enrichment and Decay Time for the “4-out-of-4 with 2 RCCAs” Storage Configuration..... 95

Table 5-5. Minimum Required Assembly Burnup versus Initial ²³⁵U Enrichment for the “4-out-of-4 with 2 RackSavers and Axial Blankets” Storage Configuration 96

Table 5-6. Minimum Required Assembly Burnup versus Initial ²³⁵U Enrichment for the “4-out-of-4 with 3 RackSavers and Axial Blankets” Storage Configuration..... 97

Table 5-7. Minimum Required Assembly-Average Burnup versus Initial ²³⁵U Enrichment and Decay Time for the “3-out-of-4” Storage Configuration 98

Table 5-8. Minimum Required Assembly-Average Burnup versus Initial ²³⁵U Enrichment and Decay Time for the “3-out-of-4 with Axial Blankets” Storage Configuration 99

Table 5-9. Minimum Required Assembly Burnup versus Initial ²³⁵U Enrichment for the “2-out-of-4” Storage Configuration 100

Figure 5-6. "2-out-of-4" Storage Configuration Illustration..... 106

Figure 5-7. Minimum Required Fuel Assembly Burnup versus Initial ^{235}U Enrichment for the "4-out-of-4" Storage Configuration..... 107

Figure 5-8. Minimum Required Fuel Assembly Burnup versus Initial ^{235}U Enrichment for the "4-out-of-4 with Axial Blankets" Storage Configuration..... 108

Figure 5-9. Minimum Required Fuel Assembly Burnup versus Initial ^{235}U Enrichment for the "4-out-of-4 with 1 RCCA" Storage Configuration..... 109

Figure 5-10. Minimum Required Fuel Assembly Burnup versus Initial ^{235}U Enrichment for the "4-out-of-4 with 2 RCCAs" Storage Configuration 110

Figure 5-11. Minimum Required Fuel Assembly Burnup versus Initial ^{235}U Enrichment for the "4-out-of-4 with 2 RackSavers and Axial Blankets" Storage Configuration 111

Figure 5-12. Minimum Required Fuel Assembly Burnup versus Initial ^{235}U Enrichment for the "4-out-of-4 with 3 RackSavers and Axial Blankets" Storage Configuration 112

Figure 5-13. Minimum Required Fuel Assembly Burnup versus Initial ^{235}U Enrichment for the "3-out-of-4" Storage Configuration..... 113

Figure 5-14. Minimum Required Fuel Assembly Burnup versus Initial ^{235}U Enrichment for the "3-out-of-4 with Axial Blankets" Storage Configuration..... 114

Figure 5-15. Minimum Required Fuel Assembly Burnup versus Initial ^{235}U Enrichment for the "2-out-of-4" Storage Configuration..... 115

1.0 Objective

This report presents the results of the criticality safety analysis for Region II of the Comanche Peak Units 1 and 2 spent fuel pool racks with reactivity credit for burnup, rod cluster control assemblies (RCCAs), RackSaver inserts, axial blankets and ^{241}Pu decay. The primary objectives of this calculation are outlined below.

1. Determine the loading requirements for safe storage of fresh fuel assemblies in the following storage configurations.
 - “4-out-of-4”
 - “4-out-of-4 with Axial Blankets”
 - “4-out-of-4 with 1 RCCA”
 - “4-out-of-4 with 2 RCCAs”
 - “4-out-of-4 with 2 RackSavers and Axial Blankets”
 - “4-out-of-4 with 3 RackSavers and Axial Blankets”
 - “3-out-of-4”
 - “3-out-of-4 with Axial Blankets”
 - “2-out-of-4”
2. Determine the fuel assembly burnup versus initial enrichment requirements for safe storage of depleted fuel assemblies in each storage configuration. Reactivity credit for ^{241}Pu decay is considered in various storage configurations.
3. Determine the loading requirements at the interface between fuel assembly storage configurations.
4. Determine the amount of soluble boron required to maintain k_{eff} less than or equal to 0.95 in the spent fuel pools, including all biases and uncertainties, assuming the most limiting plausible reactivity accident.

The criticality safety methodology used in this analysis is analogous to that which was previously approved by the Nuclear Regulatory Commission (NRC) in Reference 1. [

] ^{a,c}

1.1 Design Criteria

The design criteria are consistent with General Design Criterion (GDC) 62, Reference 2, and this analysis considers NRC guidance given in Reference 3 and general guidance from ANSI/ANS-8.17-2004 recommendations in Reference 4. Section 2.0 describes the analysis methods and includes a description of the computer codes used to perform the criticality safety analysis. A brief summary of the analysis approach and criteria is outlined below.

1. Determine the fresh fuel storage configurations such that there is a 95 percent probability at a 95 percent confidence level that the neutron multiplication factor, k_{eff} , is less than 0.995. This is accomplished with infinite arrays of fresh fuel assembly configurations. Note that the actual NRC k_{eff} limit for this condition is less than 1.0. Therefore, an additional margin of $0.005 \Delta k_{\text{eff}}$ units is included in the analysis results.
2. For the storage configurations that utilize burnup credit, determine the spent fuel assembly minimum burnup requirements such that there is a 95 percent probability at a 95 percent confidence level that k_{eff} is less than 0.995. This is accomplished with infinite arrays of spent fuel assembly configurations.
3. Determine the amount (ppm) of soluble boron necessary to reduce the k_{eff} value of all storage configurations by at least $0.05 \Delta k_{\text{eff}}$ units. This is accomplished by constructing a model of the entire spent fuel pool which includes the storage configurations which are least sensitive to changes in soluble boron concentration. As an example, storage configurations which contain depleted fuel assemblies (and represented by depleted nuclides) are less reactivity-sensitive to changes in soluble boron concentration than a fuel assembly represented by zero burnup and relatively low initial fuel enrichment.
4. Determine the amount of soluble boron necessary to compensate for 5% of the maximum burnup credited in any storage configuration. In addition, determine the amount of soluble boron necessary to account for a reactivity depletion uncertainty of 1.0% Δk_{eff} per 30,000 MWd/MTU of credited fuel burnup. This is accomplished by multiplying this derivative by the maximum burnup credited in any storage configuration and converting to soluble boron using the data generated in Step 3.
5. Determine the increase in reactivity caused by postulated accidents and the corresponding amount of soluble boron necessary to mitigate the single largest reactivity increase. This is accomplished by constructing a model of the entire Comanche Peak Units 1 and 2 spent fuel pools.

For purposes of this analysis, spent fuel minimum burnup requirements are determined in a manner that conservatively takes into account approximations to the operating history of the fuel assemblies. [

] ^{a,c}

2.0 Methodology

This section discusses the nuclear design software, key methodologies and assumptions employed in this analysis to define requirements for the safe loading of fresh and depleted fuel assemblies in the Comanche Peak Units 1 and 2 spent fuel pools.

2.1 Nuclear Design Software

The analysis methodology employs the following software: (1) SCALE version 4.4, as documented in Reference 5, with the SCALE version 4.4 versions of the 44- and 238-group Evaluated Nuclear Data File Version 5 (ENDF/B-V) neutron cross section libraries, and (2) the two-dimensional transport lattice code PHOENIX-P, as documented in Reference 15, with an Evaluated Nuclear Data File Version 6 (ENDF/B-VI) neutron cross section library.

SCALE is utilized for reactivity determinations of fuel assemblies in the Comanche Peak Units 1 and 2 spent fuel pools. The PHOENIX-P code is used for simulation of in-reactor fuel assembly depletion. The following sections describe the application of these codes in more detail.

2.1.1 The SCALE Code

The SCALE system was developed for the NRC to satisfy the need for a standardized method of analysis for evaluation of nuclear fuel facilities and shipping package designs. The SCALE version that is utilized for this analysis is a code system that runs on UNIX workstations and includes the control module CSAS25 and the following functional modules: BONAMI, NITAWL-II, and KENO V.a. All references to KENO in the text to follow should be interpreted as referring to the KENO V.a module.

NRC Information Notice 2005-13 was issued concerning an error in SCALE associated with cylindrical holes with shared boundaries. In this analysis, the KENO geometry does not involve cylindrical holes with shared boundaries; therefore, the analysis is not affected by this code error. Also, NRC Information Notice 2005-31 notifies SCALE version 5 users of a KENO programming error in slab geometry. Since this analysis utilizes SCALE 4.4, and slab geometry is not used, this analysis is not affected by this error.

Standard material compositions are employed in the SCALE analyses consistent with the design input given in Section 3.0; these data are listed in Table 2-1. For fresh fuel conditions, the fuel nuclide number densities are derived within the CSAS25 module using input consistent with the data of Table 2-1. For depleted fuel representations, the fuel nuclide number densities are derived from the PHOENIX-P code as described in Section 2.1.2.

The validation of SCALE for purposes of fuel storage rack analyses is based on the analysis of selected critical experiments from two experimental programs. The first program is the Babcock & Wilcox (B&W) experiments carried out in support of Close Proximity Storage of Power Reactor Fuel, Reference 6. The second program is the Pacific Northwest Laboratory (PNL)

program carried out in support of the design of Fuel Shipping and Storage Configurations; the experiments of current interest to this effort are documented in Reference 7. Reference 8, as well as several of the relevant thermal experiment evaluations in Reference 9, is found to be useful in updating pertinent experimental data for the PNL experiments.

Nineteen experimental configurations are selected from the B&W experimental program; these consist of the following experimental cores: Core X, the seven measured configurations of Core XI, Cores XII through XXI, and Core XIII A. These analyses employ measured critical data, rather than the extrapolated configurations to a fixed critical water height reported in Reference 6, so as to avoid introducing possible biases or added uncertainties associated with the extrapolation techniques. In addition to the active fuel region of the core, the full environment of the latter region, including the dry fuel above the critical water height, is represented explicitly in the analyses.

The B&W group of experimental configurations employs variable spacing between individual rod clusters in the nominal 3 x 3 array. In addition, the effects of placing either 304-type stainless steel (SS-304) or borated aluminum (BORAL) plates of different boron contents in the water channels between rod clusters are measured. Table 2-2 summarizes the results of these analyses.

Eleven experimental configurations are selected from the PNL experimental program. These experiments include unpoisoned uniform arrays of fuel pins and 2 x 2 arrays of rod clusters with and without interposed SS-304 or BORAL plates of different neutron absorbing effectiveness. As in the case of the B&W experiments, the full environment of the active fuel region is represented explicitly. Table 2-3 summarizes the results of these analyses.

The approach employed for the determination of the mean calculational bias and the mean calculational variance is based on Criterion 2 of Reference 10. For a given KENO-calculated value of k_{eff} and associated one sigma uncertainty, the magnitude of $k_{95/95}$ is computed by the following equation; by this definition, there is a 95 percent confidence level that in 95 percent of similar analyses the validated calculational model will yield a multiplication factor less than $k_{95/95}$.

$$k_{95/95} = k_{\text{keno}} + \Delta k_{\text{bias}} + M_{95/95} (\sigma_m^2 + \sigma_{\text{KENO}}^2)^{1/2}$$

Where,

k_{keno} is the KENO-calculated neutron multiplication factor,

Δk_{bias} is the mean calculational method bias,

$M_{95/95}$ is the 95/95 multiplier appropriate to the degrees of freedom for the number of validation analyses, and is obtained from the Tables of Reference 11,

σ_m^2 is the mean calculational method variance deduced from the validation analyses,

σ_{KENO}^2 is the square of the KENO standard deviation.

The equation for the mean calculational methods bias is as follows.

$$\Delta k_{bias} = \frac{1}{n} \sum_{i=1}^n (1 - k_i)$$

Where,

k_i is the i^{th} value of the multiplication factor for the validation lattices of interest.

The equation for the mean calculational variance of the relevant validating multiplication factors is as follows.

$$\sigma_m^2 = \frac{n \sum_{i=1}^n (k_i - k_{ave})^2 \sigma_i^{-2}}{(n-1) \sum_{i=1}^n \sigma_i^{-2}} - \sigma_{ave}^2$$

Where,

k_{ave} is given by the following equation.

$$k_{ave} = \frac{\sum_{i=1}^n k_i \sigma_i^{-2}}{\sum_{i=1}^n \sigma_i^{-2}},$$

σ_{ave}^2 is given by the following equation.

$$\sigma_{ave}^2 = \frac{\sum_{i=1}^n \sigma_i^2 G_i}{\sum_{i=1}^n G_i},$$

Where,

G_i is the number of generations.

For the purpose of this bias evaluation, the data points of Table 2-2 and Table 2-3 are collected into a single group. With this approach, the mean calculational methods bias, Δk_{bias} , and the

mean calculational variance, (σ_m^2), calculated by the equations given above, are determined to be []^{a,c}, respectively. The magnitude of $M_{95/95}$ is obtained from Reference 11 for the total number of collected data points, 30.

The magnitude of $k_{95/95}$ is, therefore, given by the following equation for SCALE 4.4 KENO analyses employing the 44-group ENDF/B-V neutron cross section library and for analyses where these experiments are a suitable basis for assessing the methods bias and calculational variance.

$$[]^{a,c}$$

The SCALE version 4.4 version of the 238-group ENDF/B-V neutron cross section library is also utilized in this analysis. However, this library is only utilized for off-nominal temperature simulations (greater than 68 °F). The 238-group library is a general purpose library that is applicable at all temperatures. The 44-group library was collapsed using a representative spectrum from a 17x17 PWR assembly at 68 °F, so any deviations from these conditions should be considered as potentially moving outside the basis of applicability for this specialized library. In addition, these calculations are only considered in a relative sense, to establish the reactivity changes due to temperature deviations. Since there is no need to quantify the absolute magnitude of the reactivity at these conditions, a comprehensive validation analysis is not performed for the 238-group neutron cross section library.

2.1.2 The PHOENIX-P Code

PHOENIX-P is a two-dimensional, multi-group transport theory lattice code. The multigroup cross sections are based on ENDF/B-VI. PHOENIX-P performs a two-dimensional 70-group nodal flux calculation which couples the individual sub-cell regions (pellet, cladding, and moderator) as well as surrounding rods via a collision probability technique. This 70-group solution is normalized by a coarse-energy-group S_4 flux solution derived from a discrete ordinates calculation. [

] ^{a,c}

[

] ^{a,c}

PHOENIX-P and its neutron cross section library are employed in the design of initial and reload cores that have supported over 500 reactor-years of operation.

For the purpose of spent fuel criticality analysis calculations, PHOENIX-P is used to generate the detailed fuel nuclide number densities as a function of fuel depletion and initial feed enrichment. Each complete set of fuel nuclides is reduced to a smaller set of depleted fuel nuclides at specific time points after discharge. [

] ^{a,c}

[

] ^{a,c}

2.2 Axial Burnup Distribution Modeling

A key aspect of the burnup credit methodology employed in this analysis is the inclusion of an axial burnup profile correlated with feed enrichment and discharge burnup of the depleted fuel assemblies. This effect can be important in the analysis of the fuel assembly characteristics when the majority of spent fuel assemblies stored in the Comanche Peak Units 1 and 2 spent fuel pools have a discharge burnup well beyond the limit for which the assumption of a uniform axial burnup shape is conservative. Therefore, it is necessary to consider both uniform and axially distributed burnup profiles, and the more conservative representation will be utilized to determine fuel assembly storage requirements.

[

] ^{a,c}

[

] ^{a,c}

[

] ^{a,c}

Input to this analysis is based on a limiting axial burnup profile data provided in the DOE Topical Report, as documented in Reference 12. The burnup profile in the DOE topical report is based on a database of 3169 axial burnup profiles for PWR fuel assemblies compiled by Yankee Atomic. This profile is derived from the burnups calculated by utilities or vendors based on core-follow calculations and in-core measurement data. [

] ^{a,c}

PHOENIX-P is used to generate the nuclide number densities for each segment of the axial profile. Table 3-6 and Table 3-7 list the relative power and moderator temperatures employed in the depletion calculations for each node of the [] ^{a,c} axial burnup models. The assembly-average uniform burnup models utilize the core-average operating conditions. These values are based on conservative temperature profiles for Comanche Peak Units 1 and 2 at uprated conditions. The use of uprated conditions for depletion calculations – with increased power, moderator temperatures and fuel temperatures – lead to increased reactivity determinations at any given burnup relative to fuel irradiated in the core prior to the uprate. The fuel temperatures for each axial zone are calculated based on a representative fuel temperature correlation while the moderator temperatures are based on a linear relationship with axial position. These node-dependent moderator, fuel temperature and power profile data are employed in PHOENIX-P to deplete the fuel to the desired burnup value for each initial enrichment and each axial zone.

[

] ^{a,c}

[

] ^{a,c}

2.3 Decay Time Credit Methodology

Due to the reactivity requirements for fuel storage in certain storage configurations, ²⁴¹Pu decay and ²⁴¹Am production credit is included in the burnup credit determinations. The ²⁴¹Pu number densities are decayed according to the equation below using a half life, $t_{1/2}$, value of 14.4 years.

$$N_{Pu}(t) = N_{o,Pu} \cdot e^{\frac{-\ln(2)}{t_{1/2}} t}$$

Where,

$N_{Pu}(t)$ = the ²⁴¹Pu number density at time t ,

$N_{o,Pu}$ = the initial ²⁴¹Pu number density,

t = the decay time in years.

Since the production rate of ²⁴¹Am is equal to the rate of ²⁴¹Pu decay, the ²⁴¹Am number densities are determined according to the equation below.

$$N_{Am}(t) = N_{o,Pu} \left(1 - e^{\frac{-\ln(2)}{t_{1/2}} t} \right)$$

Where,

$N_{Am}(t)$ = the ²⁴¹Am number density at time t .

These number densities are determined at each assembly burnup at various time intervals.

2.4 Methodology Assumptions

The key design assumptions utilized in the Comanche Peak Units 1 and 2 spent fuel pool criticality safety analysis are listed below.

- Fresh and depleted fuel assemblies are conservatively modeled with a fuel stack density equal to 10.686 g/cm^3 (97.5% of theoretical UO_2 density).
- All fuel assemblies, fresh and depleted, are modeled as containing solid right cylindrical pellets that are uniformly enriched over the entire length of the fuel stack height. No credit is taken for the presence of pellet dishing or chamfering. Due to the increased amount of fissile material in this representation, fuel assembly designs which incorporate lower enrichment blankets and/or annular pellets are bounded.
- The stainless steel wrappers that are present in the Comanche Peak Unit 2 Region II storage racks are not modeled in this analysis. This material is ignored such that the Unit 1 and Unit 2 Region II storage racks can utilize a single criticality safety analysis. This leads to a conservative representation of the Unit 2 storage racks since the wrapper's inherent neutron absorption is not considered.
- Comanche Peak Units 1 and 2 fuel assemblies currently utilize ZIRLO^{TM, 1} fuel cladding; however, the KENO models developed in this analysis consider the fuel rod, guide tube, and instrumentation tube cladding material as Zircaloy-4. This is conservative with respect to the Westinghouse ZIRLOTM product, which is a zirconium alloy containing additional elements such as niobium. Niobium has a small neutron absorption cross section, which provides additional neutron capture in the cladding regions resulting in a lower reactivity relative to Zircaloy-4. Therefore, this analysis is conservative with respect to fuel assemblies containing ZIRLOTM cladding in fuel rods, guide tubes, and the instrumentation tube.
- No credit is taken for spacer grids or spacer sleeves.
- No credit is taken for ^{234}U or ^{236}U in fresh fuel assemblies.
- The design basis limit for k_{eff} is conservatively reduced from 1.0 to 0.995 for this analysis.

¹ ZIRLOTM trademark property of Westinghouse Electric Company LLC

Table 2-1. Standard Material Compositions Employed in the Comanche Peak Units 1 and 2 Spent Fuel Pool Criticality Analysis

Material	Composition Description	
Fresh UO₂	Fraction of Theoretical Density = 0.975 (corresponding to 10.686 g/cm ³) @ 293.15 K	
Zircaloy-4 Cladding	SCALE Standard Composition Library $\rho = 6.56 \text{ g/cm}^3$ @ 293.15 K	
Water	SCALE Standard Composition Library $\rho = 1.0 \text{ g/cm}^3$ @ 293.15 K	
Type-304 Stainless Steel	SCALE Standard Composition Library $\rho = 7.94 \text{ g/cm}^3$ @ 293.15 K	
Concrete	SCALE Standard Composition Library $\rho = 2.30 \text{ g/cm}^3$ @ 293.15 K	
Metamic Density = 2.66 g/cm³ @ 293.15 K	Element/Compound	Mass Fraction
	B ₄ C	0.23
	Al	0.77
Ag-In-Cd Density = 10.17 g/cm³ @ 293.15 K	Element	Mass Fraction
	Ag	0.80
	In	0.15
	Cd	0.05
Depleted Ag-In-Cd Density = 5.085 g/cm³ @ 293.15 K	Element	Mass Fraction
	Ag	0.80
	In	0.15
	Cd	0.05

Table 2-2. Calculational Results for Cores X Through XXI of the B&W Close Proximity Experiments a, c

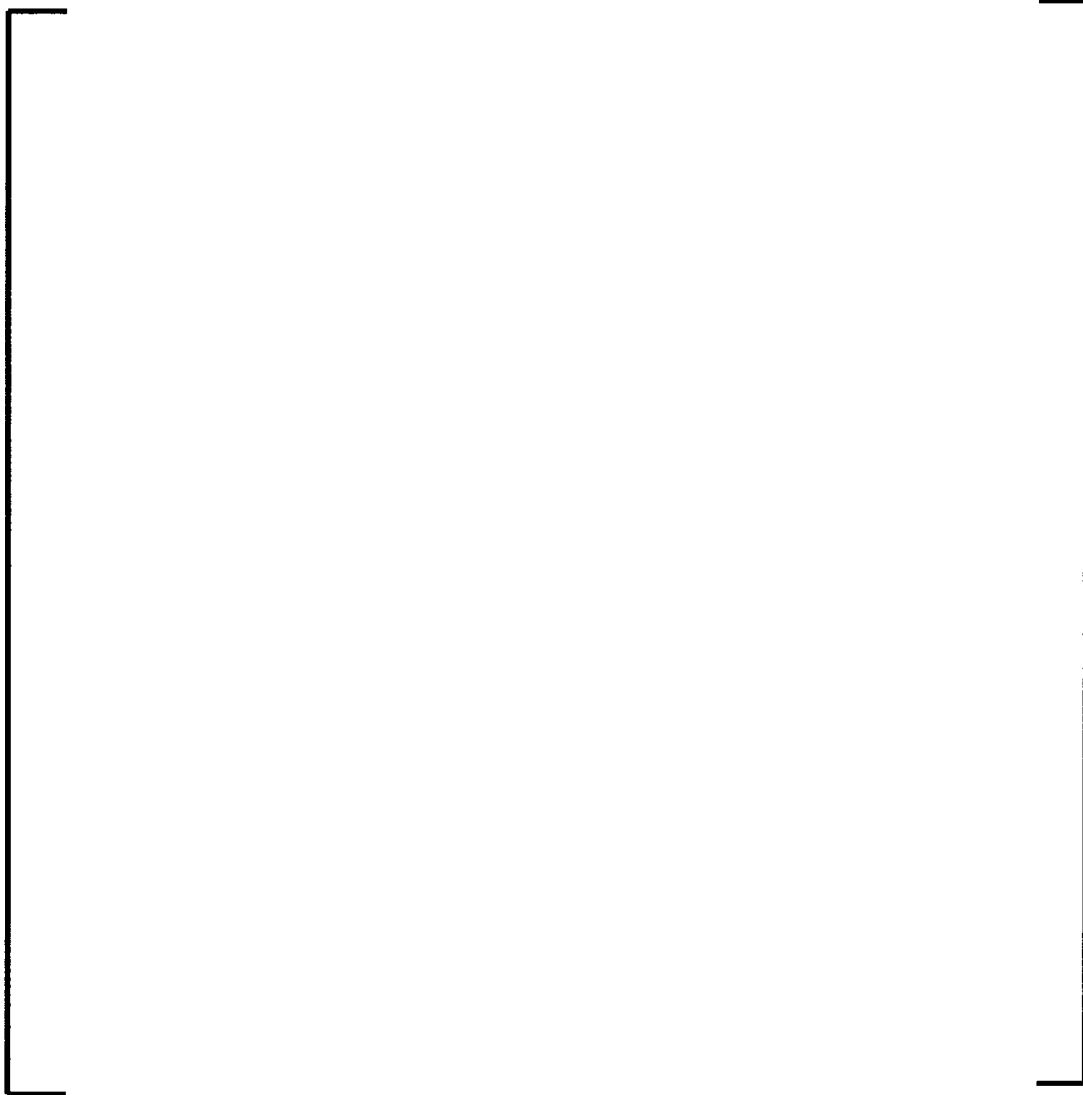
A large, empty rectangular frame with a thin black border, centered on the page. It appears to be a placeholder for a table that is not present in this version of the document.

² Entry indicates metal separating unit assemblies.

³ Entry indicates spacing between unit assemblies in units of fuel rod pitch.

Table 2-3. Calculational Results for Selected Experimental PNL Lattices, Fuel Shipping and Storage Configurations

a,c

A large, empty rectangular frame with a thin black border, spanning most of the width and height of the page. It appears to be a placeholder for a table or a large figure that is not present in this version of the document.

“This page intentionally left blank.”

3.0 Design Input

This section provides a brief description of Region II of the Comanche Peak Units 1 and 2 spent fuel pools and applicable assembly designs with the objective of establishing a basis for the analytical models employed in the criticality analysis described in Section 4.0.

3.1 Customer Design Input

Design data related to the Comanche Peak Units 1 and 2 spent fuel pool that are required to develop the KENO models are obtained from Reference 14. This document contains all dimensions pertinent to Region II of the spent fuel storage rack modules.

3.2 Comanche Peak Units 1 and 2 Spent Fuel Pool Region II Layout Description

The Comanche Peak Units 1 and 2 spent fuel pool layouts and general dimensions are depicted in Figure 3-1 and Figure 3-2. The pools consist of multiple Region I and Region II rack modules; these regions have different reactivity characteristics such that they must be analyzed separately. Note that only Region II is considered in this criticality safety analysis.

The Region II rack modules are located a minimum of 5.75 inches from the spent fuel pool wall, and 19.32 inches at a maximum. The minimum intra-module gap is 2.0 inches. Additional pertinent dimension details are summarized in Table 3-1 through Table 3-4.

3.3 Comanche Peak Units 1 and 2 Region II Storage Rack Cell Description

Region II storage cells utilize a non-flux trap design that initially intended to incorporate Boraflex as a fixed neutron poison. However, due to known Boraflex degradation issues at the time of construction, this fixed neutron poison was removed. The Unit 2 storage racks contain a stainless steel wrapper with dimensions similar to the originally-designed Boraflex wrappers, but this material is conservatively omitted from this analysis.

This rack design's storage cells are formed by welding open stainless steel canisters together at the corners. Therefore, the Region II storage cells are a combination of individual canister storage cells and *developed* storage cells. The developed storage cells result from the welding process. As an example, the welding of four canisters at the corners of each canister produces a single developed storage cell at the center of the four canisters.

The dimensions of the Region II storage cells are summarized in Table 3-1 (the developed storage cells result from the combination of these dimensions).

3.4 RackSaver Poison Insert Description

The RackSaver inserts, which are to be utilized in the Comanche Peak Units 1 and 2 spent fuel pools, are chevron-shaped and fabricated from two sheets of aluminum-boron carbide metal matrix composite material (Al-B₄C). The completed poison insert dimensions are: 8.5 inches in width, 152.7 inches in length (the lower end stops above the lower spacer grid), and 0.080 inches

in thickness. The metamic material is 77.0 w/o AA Type 6061 aluminum and 23.0 w/o boron carbide. The B₄C is ASTM C750 Type 3 isotopically-graded. The dimensions and tolerances are summarized in Table 3-2.

3.5 Rod Cluster Control Assembly Poison Insert Description

The rod cluster control assembly (RCCA) inserts credited in this analysis are previously discharged assemblies from core operation. The RCCAs are spider-mounted assemblies which contain 24 rodlets. Each rodlet contains a clad stack of Ag-In-Cd absorber pellets. The RCCA will be inserted in the fuel assembly stored in the pool. The bottom 6 inch portion of the RCCA was depleted 50% to conservatively bound the actual poison depletion experienced while in service. All structural, cladding, and absorber material located above the top of the RCCA assembly is neglected. The dimensions and tolerances are summarized in Table 3-3.

3.6 Oversize Inspection Cell Description

Oversized inspection cells are installed in Region I of the Unit 2 spent fuel pool and in Region II of the Unit 1 spent fuel pool. The oversized inspection cells are sized to replace a 2x2 region of the module in which they are installed. The inspection cells are not licensed for fuel storage, but can be used as space for a fuel assembly to be manipulated during an inspection. The Region I oversized inspection cell is not considered in this analysis. The dimensions of the Unit 1 Region II oversized inspection cell are summarized in Table 3-4.

3.7 Fuel Assembly Design Parameters

The Comanche Peak Units 1 and 2 have been operating for many years. During that time a variety of reload fuel regions containing different fuel assembly designs have been irradiated in the reactors. In the future, additional fuel assembly designs may be irradiated. Thus, the criticality safety analysis of the Comanche Peak Units 1 and 2 spent fuel pools must take into account possible differences in the reactivity characteristics of different assembly types. For the purposes of this analysis, applicable fuel assembly types were surveyed so as to define a reference fuel assembly design that would assure conservative results for the analysis.

The design parameters of the Westinghouse and Siemens 17x17 STD and OFA fuel assembly types are summarized in Table 3-5. Illustrations of these designs are contained in Figure 3-4 and Figure 3-5. Simulations are performed for each storage configuration in this analysis to determine the fuel assembly combinations that produce the highest reactivity.

The use of design basis fuel assembly types in each individual storage configuration's analysis will ensure the criticality safety of storage of Westinghouse and Siemens 17x17 STD and OFA fuel assembly types in the Comanche Peak Units 1 and 2 spent fuel pools.

The design basis fuel designs are discussed further in Section 4.0.

3.8 Core Operating Conditions

The core operating conditions considered in all depletion calculations are representative of uprated Comanche Peak Units 1 and 2 reactor cores. The zone-averaged relative power levels are generic []^{a,c} relative power levels utilized in depletion calculations for Westinghouse spent fuel pool analyses. [

] ^{a,c} The power levels (relative to 3612 MWt) and moderator temperatures specific to uprated Comanche Peak reactor cores (during extended power uprate conditions) are summarized in Table 3-6 and Table 3-7. These axial power and moderator temperature distributions are illustrated in Figure 3-6 and Figure 3-7. [] ^{a,c} moderator temperatures are determined assuming an axially-linear temperature distribution in the core. The use of uprated core conditions leads to conservative determinations of reactivity. This is due to the increased production of Pu nuclides from the slightly hardened neutron spectrum that results from increased power and temperature values. Therefore, the assembly representations are more reactive at any given point in their depletions.

Table 3-1. Comanche Peak Units 1 and 2 Rack Storage Cell Description

Parameter	Dimension
Cell Center-to-Center Pitch (inches)	9.00 ± 0.06
Cell Inner Dimension (inches)	8.83 ± 0.05
Cell Wall Thickness (inches)	0.075 ± 0.004
Cell Wall Material	304 stainless steel

Table 3-2. RackSaver Poison Insert Description

Parameter	Dimension
RackSaver ¹⁰ B Loading (w/o)	23.0 ^{+0.0} _{-1.0}
RackSaver Poison Width (inches)	8.5 ± 1/16
RackSaver Poison Thickness (inches)	0.080 ^{+0.004} _{-0.000}
RackSaver Poison Length (inches)	152.7 ± 1/8
RackSaver Poison Material	Al-B ₄ C

Table 3-3. RCCA Poison Insert Description

a, c

A large, empty rectangular frame with a thin black border, spanning most of the width and height of the page. It is positioned between the caption and the text 'a, c'. The interior of the frame is completely blank, suggesting that the table content is either redacted or has not been rendered in this view.

Table 3-4. Region II Oversize Inspection Cell Description

Parameter	Dimension
Cell Inner Dimension (inches)	17.85 ± 0.04
Cell Wall Thickness (inches)	0.075
Cell Wall Material	304 stainless steel

Table 3-5. Fuel Assembly Design Data

a, c

A large, empty rectangular frame with a thin black border, spanning most of the width and height of the page. It is positioned between the caption and the text 'a, c', suggesting it was intended to contain the data for Table 3-5.

Table 3-6. Relative Power and Moderator Temperatures for the [Distributed Burnup Models

] ^{a,c}
a, c



Table 3-7. Relative Power and Moderator Temperatures for the []^{a,c}
Distributed Burnup Models



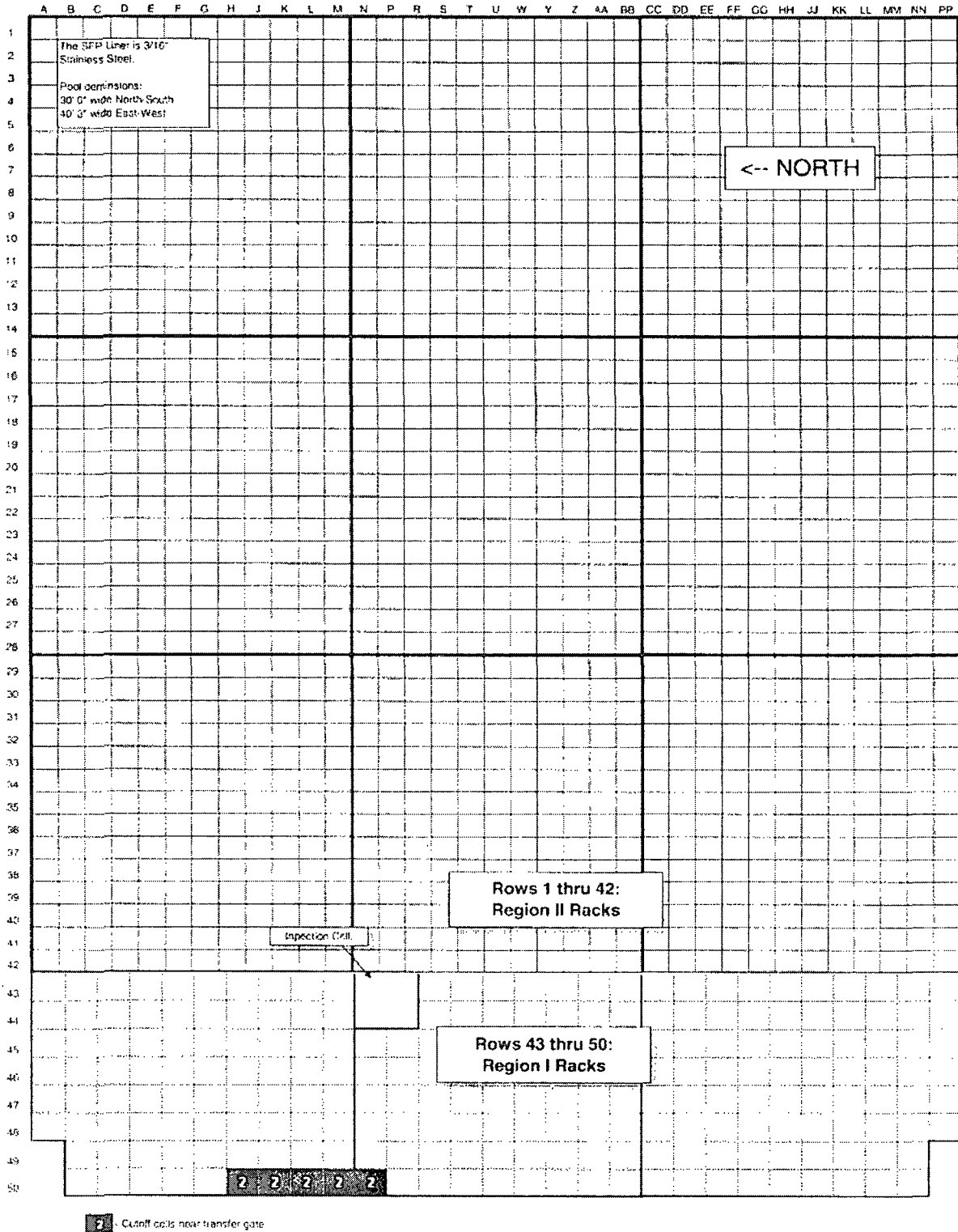

Figure 3-2. Comanche Peak Unit 2 Spent Fuel Pool Layout

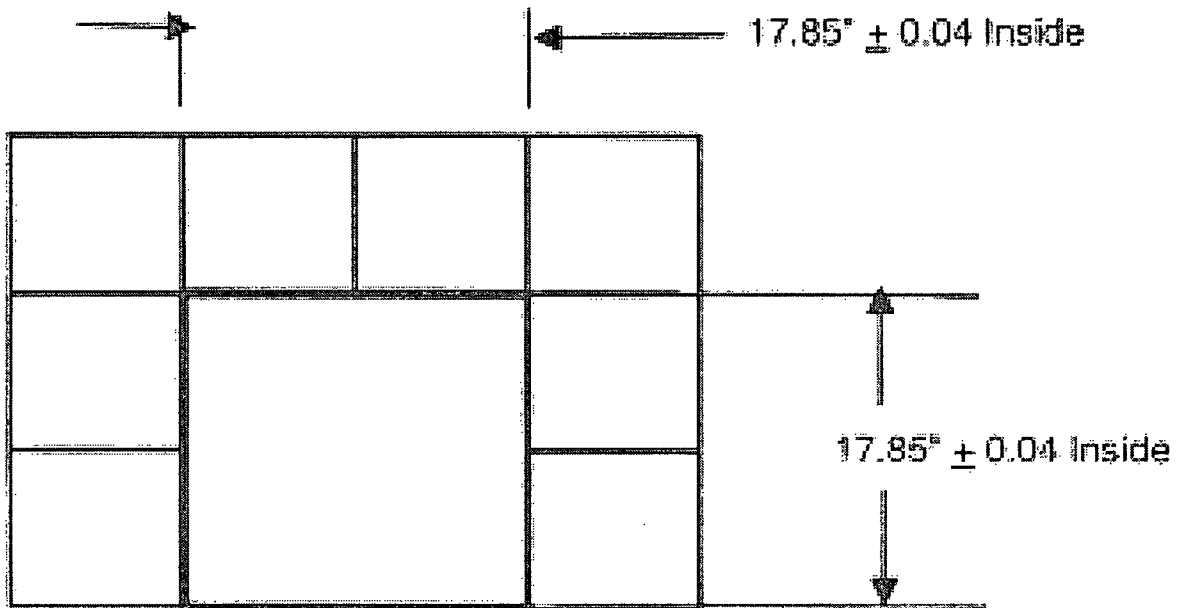

Figure 3-3. Comanche Peak Unit 1 Oversize Inspection Cell Illustration

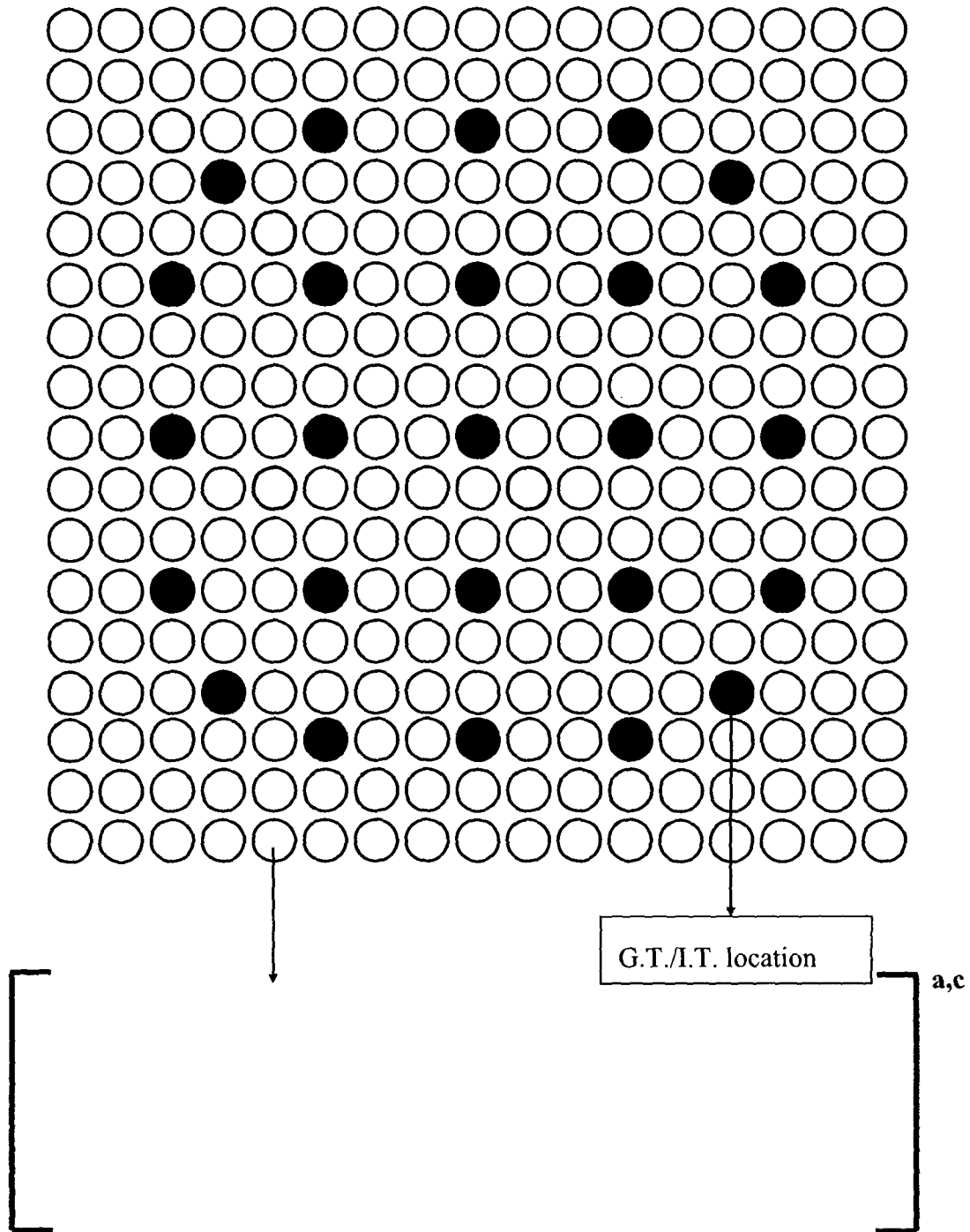

Figure 3-4. Westinghouse 17x17 STD and OFA Fuel Assembly Dimensions (all dimensions in inches, OFA dimensions are shown in parenthesis)

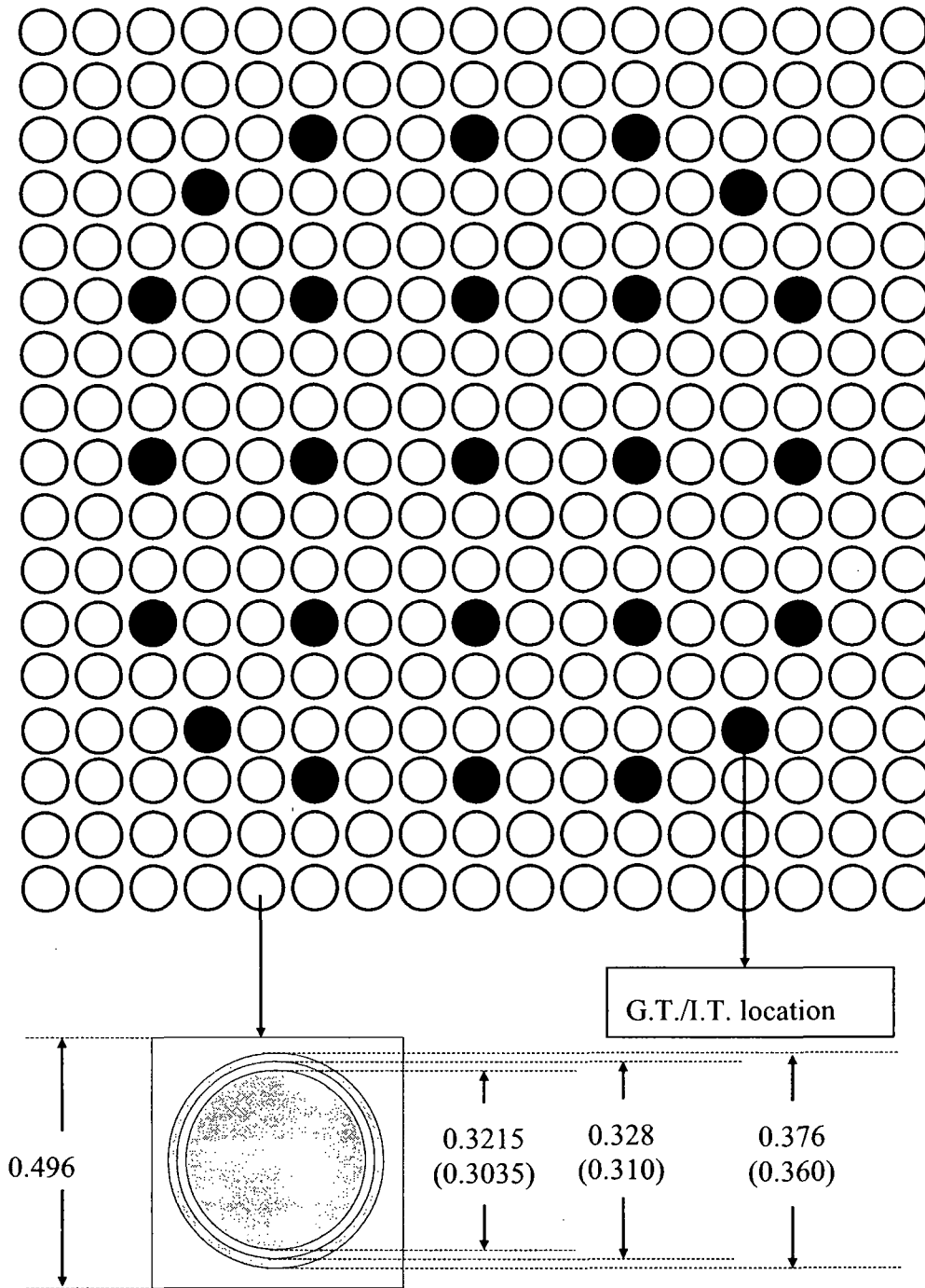

Figure 3-5. Siemens 17x17 STD and OFA Fuel Assembly Dimensions (all dimensions in inches, OFA dimensions are shown in parenthesis)

a, c

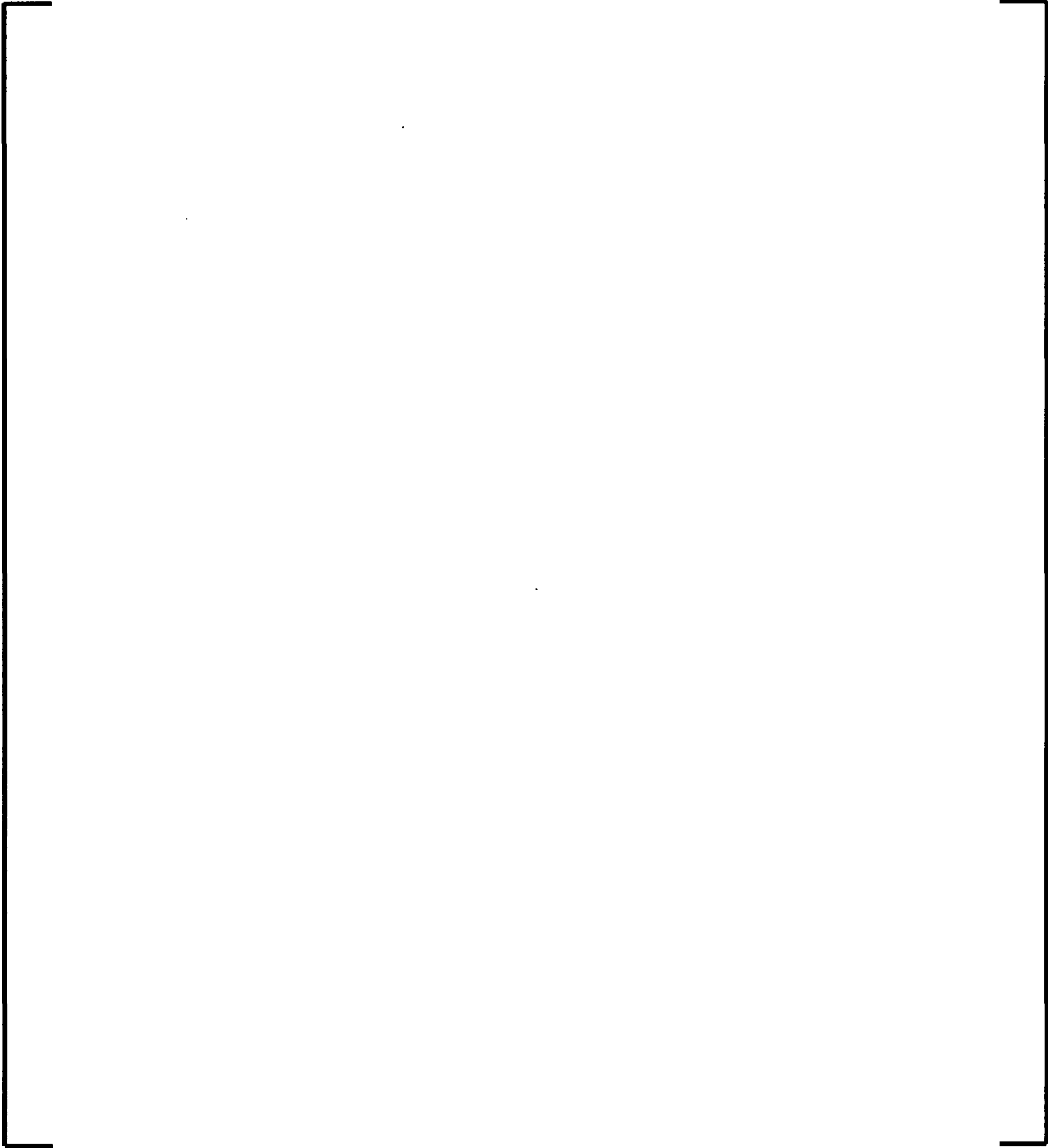

Figure 3-6. Sketch of Axial Zones Utilized in [

] ^{a,c} Distributed Burnup Fuel Assembly

Simulations

a, c

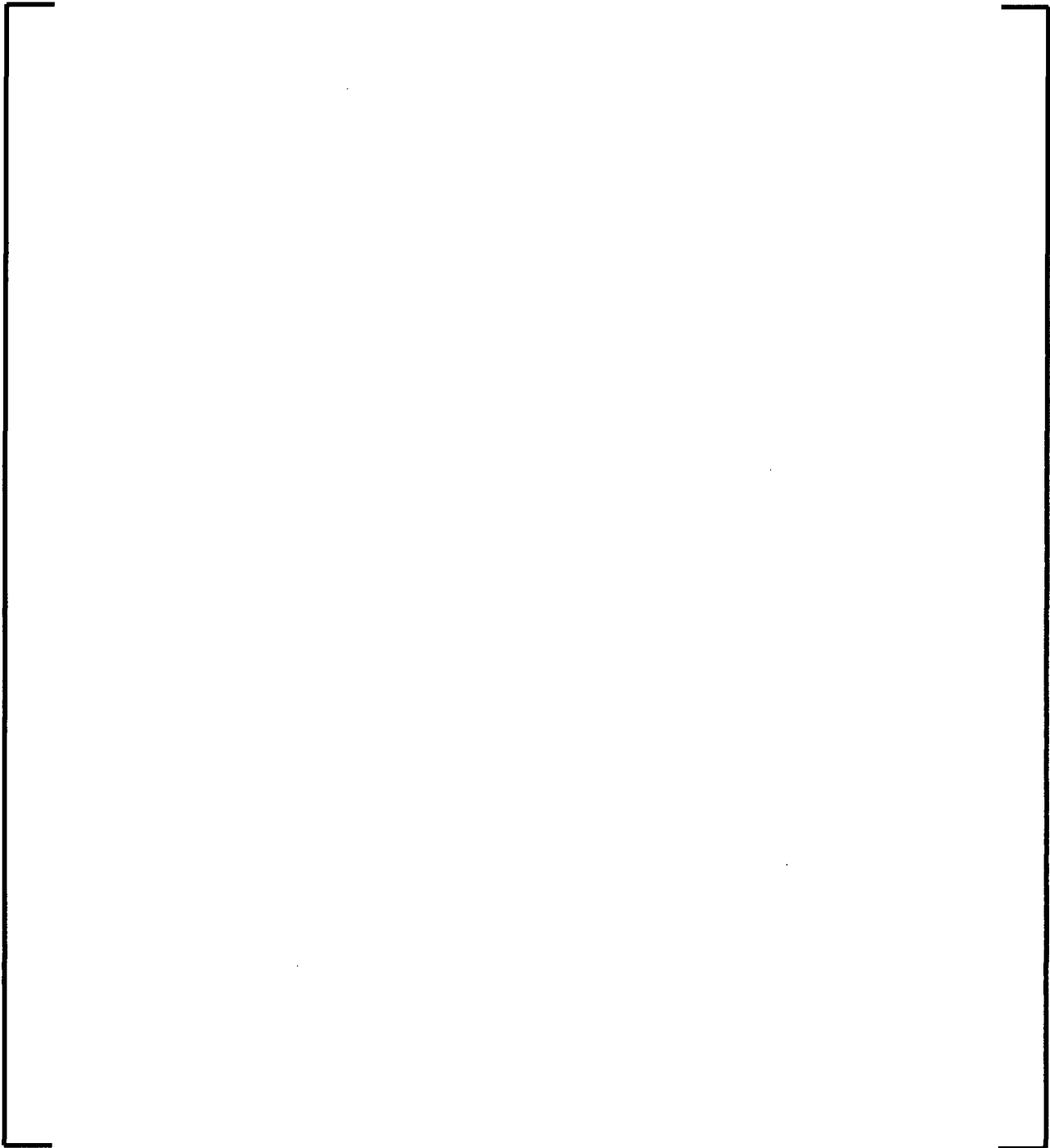

Figure 3-7. Sketch of Axial Zones Utilized in [Assembly Simulations

] ^{a,c} Distributed Burnup Fuel

“This page intentionally left blank.”

4.0 Analysis

4.1 Spent Fuel Pool Infinite Array KENO Models

The Comanche Peak Units 1 and 2 spent fuel pool analysis employs multiple fuel assembly storage configurations as follows.

- “4-out-of-4”
- “4-out-of-4 with Axial Blankets”
- “4-out-of-4 with 1 RCCA”
- “4-out-of-4 with 2 RCCAs”
- “4-out-of-4 with 2 RackSavers and Axial Blankets”
- “4-out-of-4 with 3 RackSavers and Axial Blankets”
- “3-out-of-4”
- “3-out-of-4 with Axial Blankets”
- “2-out-of-4”

Oversize inspection cells are also considered in this analysis for storage in each spent fuel pool.

The purpose of this section is to describe the models employed in infinite array KENO simulations to represent these storage configurations in the Comanche Peak Units 1 and 2 spent fuel pools. []^{a,c}

The Comanche Peak Units 1 and 2 Region II racks are modeled in KENO as a repeating 2x2 array of storage cells that contain fuel assemblies in all storage cells.

The non-flux-trap style storage cells in the storage racks are separated on a nominal 9.0 inch pitch in all directions. As described in Section 3.3, the Region II storage cells are a combination of individual canister storage cells and *developed* storage cells. Therefore, while the fuel assemblies are always nominally centered in each cell, the canister and developed storage cells have different dimensions. The stainless steel canister wall’s inner dimension is 8.83 inches and is 0.075 inches thick.

For each storage configuration, the design basis fuel type is modeled in KENO to conservatively represent the Westinghouse and Siemens 17x17 STD and OFA fuel assembly designs. For each storage configuration, the design-basis fuel assembly type may vary as a function of burnup and initial enrichment. This effect has been accounted for in all calculations. The fuel pellets in a fuel rod are modeled as fully enriched right solid cylinders that are 144 inches tall. Periodic boundary conditions are applied to the lateral (x and y) surfaces of the storage cells, thus simulating an infinitely repeating array. A water reflector is modeled above and below the storage cell geometry. The pool water is simulated at full density (1.0 g/cm^3) and at room temperature (68 °F). The top and bottom surfaces of the water reflector have reflective boundary conditions.

The assumptions from Section 2.4 are utilized in all storage configurations.

4.1.1 “4-out-of-4” and “4-out-of-4 with Axial Blankets” Storage Configuration

The “4-out-of-4” and “4-out-of-4 with Axial Blankets” storage configurations are both modeled in KENO as a repeating 2x2 array of storage cells that contain fuel assemblies in all storage cells.

Axially-blanketed assemblies in the “4-out-of-4 with Axial Blankets” storage configuration are identical to non-blanketed assemblies, except that axial burnup distributions are not considered in burnup credit calculations (as discussed in Section 2.2). In addition, biases and uncertainties are determined without explicit axial blanket modeling; therefore, the biases and uncertainties are identical for both storage configurations. This is a conservative reactivity representation of assemblies with axial blankets since explicit blankets decrease reactivity. A KENO3D-produced plot of the “4-out-of-4” and “4-out-of-4 with Axial Blankets” storage configurations is shown in Figure 4-1.

4.1.2 “4-out-of-4 with 1 RCCA” Storage Configuration

The “4-out-of-4 with 1 RCCA” storage configuration is modeled in KENO as a repeating 2x2 array of storage cells that contain fuel assemblies in all storage cells. A single assembly contains RCCA fingers inserted into the assembly guide tubes. A KENO3D-produced plot of the “4-out-of-4 with 1 RCCA” storage configuration is shown in Figure 4-2.

4.1.3 “4-out-of-4 with 2 RCCAs” Storage Configuration

The “4-out-of-4 with 2 RCCAs” storage configuration is modeled in KENO as a repeating 2x2 array of storage cells that contain fuel assemblies in all storage cells. Two diagonal assemblies contain RCCA fingers inserted into the assembly guide tubes. A KENO3D-produced plot of the “4-out-of-4 with 2 RCCAs” storage configuration is shown in Figure 4-3.

4.1.4 “4-out-of-4 with 2 RackSavers and Axial Blankets” Storage Configuration Model

The “4-out-of-4 with 2 RackSavers and Axial Blankets” storage configuration is modeled in KENO as a repeating 2x2 array of storage cells that contain fuel assemblies in all storage cells. Two diagonal storage cells contain RackSavers inserted around the fuel assemblies. The RackSavers shall be oriented in a consistent manner within contiguous storage configurations. Axially-blanketed assemblies are represented in an identical manner to that described in Section 4.1.1. A KENO3D-produced plot of the “4-out-of-4 with 2 RackSavers and Axial Blankets” storage configuration illustrates the required RackSaver orientation and is shown in Figure 4-4.

4.1.5 “4-out-of-4 with 3 RackSavers and Axial Blankets” Storage Configuration

The “4-out-of-4 with 3 RackSavers and Axial Blankets” storage configuration is modeled in KENO as a repeating 2x2 array of storage cells that contain fuel assemblies in all storage cells. Three storage cells contain RackSavers inserted around the fuel assemblies. The RackSavers shall be oriented in a consistent manner within contiguous storage configurations. Axially-blanketed assemblies are represented in an identical manner to that described in Section 4.1.1. A

KENO3D-produced plot of the “4-out-of-4 with 3 RackSavers and Axial Blankets” storage configuration illustrates the required RackSaver orientation and is shown in Figure 4-5.

4.1.6 “3-out-of-4” and “3-out-of-4 with Axial Blankets” Storage Configuration

The “3-out-of-4” and “3-out-of-4 with Axial Blankets” storage configurations are both modeled in KENO as a repeating 2x2 array of storage cells that contain fuel assemblies in three storage cells. The remaining storage cell location is empty. Axially-blanketed assemblies are represented in an identical manner to that described in Section 4.1.1. A KENO3D-produced plot of the “3-out-of-4” and “3-out-of-4 with Axial Blankets” storage configurations is shown in Figure 4-6.

4.1.7 “2-out-of-4” Storage Configuration

The “2-out-of-4” storage configuration is modeled in KENO as a repeating 2x2 array of storage cells that contain fuel assemblies in two diagonal storage cells. The remaining storage cell locations are empty. A KENO3D-produced plot of the “2-out-of-4” storage configuration is shown in Figure 4-7.

4.1.8 Oversize Inspection Cell KENO Model

The oversize inspection cell is modeled in KENO as a storage cell 17.85 inches wide in both lateral dimensions and 168 inches in axial extent. The cell wall is modeled as stainless steel 0.075 inches thick. A 5.0 w/o ^{235}U OFA fuel assembly is modeled as the design basis fuel type. In order to bound both Region II locations, the inspection cell is placed near the center of a 12 x 14 storage rack module. The OFA fuel assembly is considered in various lateral positions within the cell. An empty row of storage cells is included in all adjacent locations, including diagonal cells. The surrounding storage locations in the model contain STD fuel assemblies at the maximum permissible enrichment for the “4-out-of-4” storage configuration. A KENO3D-produced plot of the oversize inspection cell is shown in Figure 4-8 (fuel assembly is shown centered within the cell).

4.2 Biases and Uncertainties Calculations

To demonstrate that there is a 95 percent probability at a 95 percent confidence level that the neutron multiplication factor of the spent fuel pool will remain less than or equal to 0.995 at no soluble boron conditions, simulations must be performed to quantify all biases and uncertainties in the calculations. All biases and uncertainties calculations utilize the KENO models described in Section 4.1.

Applicable biases factored into this evaluation are: 1) the methodology bias deduced from the validation analyses of pertinent critical experiments, and 2) any reactivity bias, relative to the reference analysis conditions, associated with operation of the spent fuel pool over a temperature range of 50°F to 150°F.

A methodology allowance is included based on a 95/95 confidence level assessment of tolerances and uncertainties. The following are included in the summation of variances:

- a. The 95/95 confidence level methods variance,
- b. The 95/95 confidence level calculational uncertainty,

- c. Fuel assembly manufacturing tolerances,
- d. Storage rack, RCCA, and RackSaver fabrication tolerances,
- e. Tolerance due to off-center positioning of the fuel assembly or RackSaver (for applicable storage configurations) in the storage cell,
- f. Burnup measurement uncertainty.

Items a. and b. are based on the calculational methods validation analyses described in Section 2.1.1.

For item c., the fuel rod manufacturing tolerance for the reference design fuel assembly consists of the following components: an increase in pellet diameter []^{a,c}, a decrease in fuel cladding thickness []^{a,c} and an increase in fuel enrichment of []^{a,c}. A fuel density tolerance is not included since 97.5% of theoretical UO₂ density is conservatively considered in all cases. Since the magnitude of the enrichment tolerance's effect on reactivity is a strong function of the fuel enrichment at which it is evaluated (decreasing trend with increasing enrichment), the enrichment tolerance is assessed as a function of enrichment in this analysis. To account for this variation with enrichment, the enrichment is varied by []^{a,c} at the maximum allowable fresh fuel enrichment of each storage configuration and incremental enrichments up to 5.0 w/o ²³⁵U. This results in the sum of the biases and uncertainties varying with initial enrichment.

For item d., the following component tolerances are varied to their bounds: the stainless steel canister inner dimension, wall thickness, storage cell center-to-center spacing, and the RackSavers boron carbide B₄C loading. An RCCA absorber diameter tolerance []^{a,c} is considered as well as the RCCA-to-fuel alignment in the storage cell. Because Ag-In-Cd is a strong neutron absorber, the slight decrease in diameter is statistically insignificant and is neglected. The RCCA fingers are positioned to conservatively bound both alignment and length tolerances directly in the KENO models. The magnitudes of statistically significant Δk_{eff} values from manufacturing tolerances are listed in Table 4-1 through Table 4-7.

In the case of the tolerance due to positioning of the fuel assembly in the storage cells (item e.), all nominal calculations are carried out with fuel assemblies centered in the storage cells. Simulations are performed to investigate the effect of off-center position of the fuel assemblies for each of the fuel assembly storage configurations. These simulations positioned the assemblies as close as possible in four adjacent storage cells and at intermediate positions in between. Similarly, for the "4-out-of-4 with 2 RackSavers and Axial Blankets" and "4-out-of-4 with 3 RackSavers and Axial Blankets" storage configurations, the RackSavers were positioned as close as possible to the canisters and at intermediate positions to evaluate the impact of eccentric placement.

For Item f., a 5% burnup measurement uncertainty based on the maximum burnup credited for each initial enrichment in a storage configuration was applied to all the depleted fuel assemblies in that configuration. Since the burnup measurement uncertainty is dependent on the magnitude of the burnup credited in the analysis, it is determined iteratively at each initial enrichment considered in a storage configuration.

The individual contributions of all of the aforementioned tolerances and uncertainties are combined by taking the square root of the sum of the squares of each component. If the reactivity contribution from a tolerance is statistically insignificant, it is neglected in the determination of biases and uncertainties. Section 4.3 summarizes the results of the biases and uncertainties calculations and how they are incorporated into the overall storage requirements for each of the fuel assembly storage configurations.

4.3 Determination of Minimum Burnup Requirements at No Soluble Boron Conditions

To ensure that the neutron multiplication factor of the spent fuel pool will remain less than or equal to the regulatory requirement, the reactivity decrease associated with fuel burnup, RCCAs and RackSavers must be credited in the Comanche Peak Units 1 and 2 spent fuel pool. This analysis considers burnup credit established in a manner that takes into account approximations to the operating history of the fuel assemblies. Variables such as the axial burnup profile as well as the axial profile of moderator and fuel temperatures have been factored into the analysis as described in Section 2.2. Further decreases in reactivity associated with the decay of ^{241}Pu and the corresponding buildup of ^{241}Am are also considered as described in Section 2.3.

The following subsections present the KENO-calculated neutron multiplication factors for the Comanche Peak Units 1 and 2 spent fuel pool storage configurations. All burnup credit calculations utilize the KENO models described in Section 4.1. The KENO calculations reported in this section were performed at 68°F and a water density of 1.0 g/cm³. All temperature bias calculations consider the effects of storing depleted fuel and changes in moderator density. The target value of k_{eff} was selected to be less than 0.995 by an amount sufficient to cover the magnitude of the analytical biases and uncertainties in each storage configuration.

4.3.1 “4-out-of-4” Storage Configuration

As described in Section 4.1.1, the “4-out-of-4” storage configuration consists of a repeating 2x2 array of storage cells that contain fuel assemblies in all storage cells.

The k_{eff} values are calculated for an infinite array of “4-out-of-4” storage configurations over a range of initial enrichment values up to 5.0 w/o ^{235}U and assembly-average burnups up to 80,000 MWd/MTU. When evaluating the biases and uncertainties as described in Section 4.2, a fuel enrichment of 1.02 w/o ^{235}U is utilized for most calculations. The biases and uncertainties for this storage configuration, with the exception of enrichment tolerance and burnup measurement uncertainty, are given in Table 4-1. The enrichment tolerance and burnup measurement uncertainty are given in Table 4-8 at each initial enrichment considered for this storage configuration.

At the maximum allowable fresh fuel initial enrichment, the sum of the biases and uncertainties is determined to be 0.02470 Δk_{eff} units, which results in a target k_{eff} value of 0.97030 (0.995 – 0.02470) for fresh fuel. Table 4-8 also lists the sum of the biases and uncertainties and the final target k_{eff} values for depleted fuel with 2.0, 3.0, 4.0, and 5.0 w/o ^{235}U initial enrichments.

Table 4-17 lists the k_{eff} values for the “4-out-of-4” storage configuration versus initial enrichment and assembly-average burnups. The first entry Table 4-17 lists the initial enrichment for zero burnup. Based on the target k_{eff} value of 0.97030, the fresh enrichment for zero burnup

is 1.02 w/o ^{235}U . The derived burnup limits, for enrichments greater than 1.02 w/o ^{235}U , are based on the target k_{eff} values for 2.0, 3.0, 4.0, and 5.0 w/o ^{235}U from Table 4-8. At each initial enrichment, KENO calculations are performed at three assembly-average burnup values with an axially uniform and distributed burnup profile. The largest k_{eff} values from the two profiles are used to create a second degree fit of the burnup versus k_{eff} data, which were then used to determine the burnup required to meet the target k_{eff} values at each enrichment.

The resulting minimum required burnup versus initial enrichment storage limits for 0 through 20 years of decay time, in 5 year increments, are provided in Table 5-1. The limiting burnups as a function of initial enrichment were fit to fourth degree polynomials. These polynomials are given below Table 5-1 and will be used to determine the burnup as a function of initial enrichment of the “4-out-of-4” configuration. The data in Table 5-1 are plotted in Figure 5-7.

4.3.2 “4-out-of-4 with Axial Blankets” Storage Configuration

As described in Section 4.1.1, the “4-out-of-4 with Axial Blankets” storage configuration consists of a repeating 2x2 array of storage cells that contain axially-blanketed fuel assemblies in all storage cells.

The k_{eff} values are calculated for an infinite array of “4-out-of-4 with Axial Blankets” storage configurations over a range of initial enrichment values up to 5.0 w/o ^{235}U and assembly-average burnups up to 65,000 MWd/MTU. When evaluating the biases and uncertainties as described in Section 4.2, a fuel enrichment of 1.02 w/o ^{235}U is utilized for most calculations. The biases and uncertainties for this storage configuration, with the exception of enrichment tolerance and burnup measurement uncertainty, are given in Table 4-1. The enrichment tolerance and burnup measurement uncertainty are given in Table 4-9 at each initial enrichment considered for this storage configuration.

Since this configuration contains axial blankets, the enrichment will be restricted to greater than or equal to 3.0 w/o ^{235}U . At an enrichment of 3.0 w/o ^{235}U , the sum of the biases and uncertainties is determined to be 0.01996 Δk_{eff} units, which results in a target k_{eff} value of 0.97504 (0.995 – 0.01996). Table 4-9 also lists the sum of the biases and uncertainties and the final target k_{eff} values for depleted fuel with 4.0, and 5.0 w/o ^{235}U initial enrichments.

Table 4-18 lists the k_{eff} values for the “4-out-of-4 with Axial Blankets” storage configuration versus initial enrichment and assembly-average burnups. The derived burnup limits, for enrichments greater than or equal to 3.0 w/o ^{235}U , are based on the target k_{eff} values for 3.0, 4.0, and 5.0 w/o ^{235}U from Table 4-9. At each initial enrichment, KENO calculations are performed at three assembly-average burnup values with an axially uniform burnup profile. The k_{eff} values are used to create a second degree fit of the burnup versus k_{eff} data, which were then used to determine the burnup required to meet the target k_{eff} values at each enrichment.

The resulting minimum required burnup versus initial enrichment storage limits for 0 through 20 years of decay time, in 5 year increments, are provided in Table 5-2. The limiting burnups as a function of initial enrichment were fit to second degree polynomials. These polynomials are given below Table 5-2 and will be used to determine the burnup as a function of initial

enrichment of the “4-out-of-4 with Axial Blankets” configuration. The data in Table 5-2 are plotted in Figure 5-8.

4.3.3 “4-out-of-4 with 1 RCCA” Storage Configuration

As described in Section 4.1.2, the “4-out-of-4 with 1 RCCA” storage configuration consists of a repeating 2x2 array of storage cells that contain fuel assemblies in all storage cells and a RCCA in one location.

The k_{eff} values are calculated for an infinite array of “4-out-of-4 with 1 RCCA” storage configurations over a range of initial enrichment values up to 5.0 w/o ^{235}U and assembly-average burnups up to 70,000 MWd/MTU. When evaluating the biases and uncertainties as described in Section 4.2, a fuel enrichment of 1.21 w/o ^{235}U is utilized for most calculations. The biases and uncertainties for this storage configuration, with the exception of enrichment tolerance and burnup measurement uncertainty, are given in Table 4-2. The enrichment tolerance and burnup measurement uncertainty are given in Table 4-10 at each initial enrichment considered for this storage configuration.

At the maximum allowable fresh fuel initial enrichment, the sum of the biases and uncertainties is determined to be 0.02138 Δk_{eff} units, which results in a target k_{eff} value of 0.97362 (0.995 – 0.02138) for fresh fuel. Table 4-10 also lists the sum of the biases and uncertainties and the final target k_{eff} values for depleted fuel with 2.0, 3.0, 4.0, and 5.0 w/o ^{235}U initial enrichments.

Table 4-19 lists the k_{eff} values for the “4-out-of-4 with 1 RCCA” storage configuration versus initial enrichment and assembly-average burnups. The first entry in Table 4-19 lists the initial enrichment for zero burnup. Based on the target k_{eff} value of 0.97362, the fresh enrichment for zero burnup is 1.20 w/o ^{235}U . The derived burnup limits, for enrichments greater than 1.20 w/o ^{235}U , are based on the target k_{eff} values for 2.0, 3.0, 4.0, and 5.0 w/o ^{235}U from Table 4-10. At each initial enrichment, KENO calculations are performed at three assembly-average burnup values with an axially uniform and distributed burnup profile. The largest k_{eff} values from the two profiles are used to create a third degree fit of the burnup versus k_{eff} data, which were then used to determine the burnup required to meet the target k_{eff} values at each enrichment.

The resulting minimum required burnup versus initial enrichment storage limits for 0 and 10 years of decay time are provided in Table 5-3. The limiting burnups as a function of initial enrichment were fit to fourth degree polynomials. These polynomials are given below Table 5-3 and will be used to determine the burnup as a function of initial enrichment of the “4-out-of-4 with 1 RCCA” configuration. The data in Table 5-3 are plotted in Figure 5-9.

4.3.4 “4-out-of-4 with 2 RCCAs” Storage Configuration

As described in Section 4.1.3, the “4-out-of-4 with 2 RCCAs” storage configuration consists of a repeating 2x2 array of storage cells that contain fuel assemblies in all storage cells and RCCAs in diagonal locations.

The k_{eff} values are calculated for an infinite array of “4-out-of-4 with 2 RCCAs” storage configurations over a range of initial enrichment values up to 5.0 w/o ^{235}U and assembly-average burnups up to 60,000 MWd/MTU. When evaluating the biases and uncertainties as described in

Section 4.2, a fuel enrichment of 1.53 w/o ^{235}U is utilized for most calculations. The biases and uncertainties for this storage configuration, with the exception of enrichment tolerance and burnup measurement uncertainty, are given in Table 4-3. The enrichment tolerance and burnup measurement uncertainty are given in Table 4-11 at each initial enrichment considered for this storage configuration.

At the maximum allowable fresh fuel initial enrichment, the sum of the biases and uncertainties is determined to be 0.01722 Δk_{eff} units, which results in a target k_{eff} value of 0.97778 (0.995 – 0.01722) for fresh fuel. Table 4-11 also lists the sum of the biases and uncertainties and the final target k_{eff} values for depleted fuel with 2.0, 3.0, 4.0, and 5.0 w/o ^{235}U initial enrichments.

Table 4-20 lists the k_{eff} values for the “4-out-of-4 with 2 RCCAs” storage configuration versus initial enrichment and assembly-average burnups. The first entry in Table 4-20 lists the initial enrichment for zero burnup. Based on the target k_{eff} value of 0.97778, the fresh enrichment for zero burnup is 1.53 w/o ^{235}U . The derived burnup limits, for enrichments greater than 1.53 w/o ^{235}U , are based on the target k_{eff} values for 2.0, 3.0, 4.0, and 5.0 w/o ^{235}U from Table 4-11. At each initial enrichment, KENO calculations are performed at three assembly-average burnup values with an axially uniform and distributed burnup profile. The largest k_{eff} values from the two profiles are used to create a third degree fit of the burnup versus k_{eff} data, which were then used to determine the burnup required to meet the target k_{eff} values at each enrichment.

The resulting minimum required burnup versus initial enrichment storage limits for 0 and 10 years of decay time are provided in Table 5-4. The limiting burnups as a function of initial enrichment were fit to fourth degree polynomials. These polynomials are given below Table 5-4 and will be used to determine the burnup as a function of initial enrichment of the “4-out-of-4 with 2 RCCAs” configuration. The data in Table 5-4 are plotted in Figure 5-10.

4.3.5 “4-out-of-4 with 2 RackSavers and Axial Blankets” Storage Configuration Model

As described in Section 4.1.4, the “4-out-of-4 with 2 RackSavers and Axial Blankets” storage configuration consists of a repeating 2x2 array of storage cells that contain axially-blanketed fuel assemblies in all storage cells and RackSavers in diagonal locations.

The k_{eff} values are calculated for an infinite array of “4-out-of-4 with 2 RackSavers and Axial Blankets” storage configurations over a range of initial enrichment values up to 5.0 w/o ^{235}U and assembly-average burnups up to 60,000 MWd/MTU. When evaluating the biases and uncertainties as described in Section 4.2, a fuel enrichment of 1.38 w/o ^{235}U is utilized for most calculations. The biases and uncertainties for this storage configuration, with the exception of enrichment tolerance and burnup measurement uncertainty, are given in Table 4-4. The enrichment tolerance and burnup measurement uncertainty are given in Table 4-12 at each initial enrichment considered for this storage configuration.

Since this configuration contains axial blankets, the enrichment will be restricted to greater than or equal to 3.0 w/o ^{235}U . At an enrichment of 3.0 w/o ^{235}U , the sum of the biases and uncertainties is determined to be 0.01693 Δk_{eff} units, which results in a target k_{eff} value of 0.97807 (0.995 – 0.01693) for fresh fuel. Table 4-12 also lists the sum of the biases and

uncertainties and the final target k_{eff} values for depleted fuel with 4.0 and 5.0 w/o ^{235}U initial enrichments.

Table 4-21 lists the k_{eff} values for the “4-out-of-4 with 2 RackSavers and Axial Blankets” storage configuration versus initial enrichment and assembly-average burnups. The derived burnup limits, for enrichments greater than or equal to 3.0 w/o ^{235}U , are based on the target k_{eff} values for 3.0, 4.0, and 5.0 w/o ^{235}U from Table 4-12. At each initial enrichment, KENO calculations are performed at four assembly-average burnup values with an axially uniform burnup profile. The k_{eff} values are used to create a third degree fit of the burnup versus k_{eff} data, which were then used to determine the burnup required to meet the target k_{eff} values at each enrichment.

The resulting minimum required burnup versus initial enrichment storage limits are provided in Table 5-5. The limiting burnups as a function of initial enrichment were fit to fourth degree polynomials. These polynomials are given below Table 5-5 and will be used to determine the burnup as a function of initial enrichment of the “4-out-of-4 with 2 RackSavers and Axial Blankets” configuration. The data in Table 5-5 are plotted in Figure 5-11.

4.3.6 “4-out-of-4 with 3 RackSavers and Axial Blankets” Storage Configuration

As described in Section 4.1.5, the “4-out-of-4 with 3 RackSavers and Axial Blankets” storage configuration consists of a repeating 2x2 array of storage cells that contain fuel assemblies in all storage cells and RackSavers in three locations.

The k_{eff} values are calculated for an infinite array of “4-out-of-4 with 3 RackSavers and Axial Blankets” storage configurations over a range of initial enrichment values up to 5.0 w/o ^{235}U and assembly-average burnups up to 45,000 MWd/MTU. When evaluating the biases and uncertainties as described in Section 4.2, a fuel enrichment of 1.628 w/o ^{235}U is utilized for most calculations. The biases and uncertainties for this storage configuration, with the exception of enrichment tolerance and burnup measurement uncertainty, are given in Table 4-5. The enrichment tolerance and burnup measurement uncertainty are given in Table 4-13 at each initial enrichment considered for this storage configuration.

Since this configuration contains axial blankets, the enrichment will be restricted to greater than or equal to 3.0 w/o ^{235}U . At an enrichment of 3.0 w/o ^{235}U , the sum of the biases and uncertainties is determined to be 0.01556 Δk_{eff} units, which results in a target k_{eff} value of 0.97944 (0.995 – 0.01556) for fresh fuel. Table 4-13 also lists the sum of the biases and uncertainties and the final target k_{eff} values for depleted fuel with 4.0 and 5.0 w/o ^{235}U initial enrichments.

Table 4-22 lists the k_{eff} values for the “4-out-of-4 with 3 RackSavers and Axial Blankets” storage configuration versus initial enrichment and assembly-average burnups. The derived burnup limits, for enrichments greater than or equal to 3.0 w/o ^{235}U , are based on the target k_{eff} values for 3.0, 4.0, and 5.0 w/o ^{235}U from Table 4-13. At each initial enrichment, KENO calculations are performed at four assembly-average burnup values with an axially uniform burnup profile. The k_{eff} values are used to create a third degree fit of the burnup versus k_{eff} data, which were then used to determine the burnup required to meet the target k_{eff} values at each enrichment.

The resulting minimum required burnup versus initial enrichment storage limits are provided in Table 5-6. The limiting burnups as a function of initial enrichment were fit to fourth degree polynomials. These polynomials are given below Table 5-6 and will be used to determine the burnup as a function of initial enrichment of the “4-out-of-4 with 3 RackSavers and Axial Blankets” configuration. The data in Table 5-6 are plotted in Figure 5-12.

4.3.7 “3-out-of-4” Storage Configuration

As described in Section 4.1.6, the “3-out-of-4” storage configuration consists of a repeating 2x2 array of storage cells that contain fuel assemblies in three storage cells.

The k_{eff} values are calculated for an infinite array of “3-out-of-4” storage configurations over a range of initial enrichment values up to 5.0 w/o ^{235}U and assembly-average burnups up to 50,000 MWd/MTU. When evaluating the biases and uncertainties as described in Section 4.2, a fuel enrichment of 1.47 w/o ^{235}U is utilized for most calculations. The biases and uncertainties for this storage configuration, with the exception of enrichment tolerance and burnup measurement uncertainty, are given in Table 4-6. The enrichment tolerance and burnup measurement uncertainty are given in Table 4-14 at each initial enrichment considered for this storage configuration.

At the maximum allowable fresh fuel initial enrichment, the sum of the biases and uncertainties is determined to be 0.01789 Δk_{eff} units, which results in a target k_{eff} value of 0.97711 (0.995 – 0.01789) for fresh fuel. Table 4-14 also lists the sum of the biases and uncertainties and the final target k_{eff} values for depleted fuel with 2.0, 3.0, 4.0, and 5.0 w/o ^{235}U initial enrichments.

Table 4-23 lists the k_{eff} values for the “3-out-of-4” storage configuration versus initial enrichment and assembly-average burnups. The first entry in Table 4-23 lists the initial enrichment for zero burnup. Based on the target k_{eff} value of 0.97711, the fresh enrichment for zero burnup is 1.47 w/o ^{235}U . The derived burnup limits, for enrichments greater than 1.47 w/o ^{235}U , are based on the target k_{eff} values for 2.0, 3.0, 4.0, and 5.0 w/o ^{235}U from Table 4-14. At each initial enrichment, KENO calculations are performed at three assembly-average burnup values with an axially uniform and distributed burnup profile. The largest k_{eff} values from the two profiles are used to create a second degree fit of the burnup versus k_{eff} data, which were then used to determine the burnup required to meet the target k_{eff} values at each enrichment.

The resulting minimum required burnup versus initial enrichment storage limits for 0 through 20 years of decay time, in 5 year increments, are provided in Table 5-7. The limiting burnups as a function of initial enrichment were fit to fourth degree polynomials. These polynomials are given below Table 5-7 and will be used to determine the burnup as a function of initial enrichment of the “3-out-of-4” configuration. The data in Table 5-7 are plotted in Figure 5-13.

4.3.8 “3-out-of-4 with Axial Blankets” Storage Configuration

As described in Section 4.1.6, the “3-out-of-4 with Axial Blankets” storage configuration consists of a repeating 2x2 array of storage cells that contain axially-blanketed fuel assemblies in three storage cells.

The k_{eff} values are calculated for an infinite array of “3-out-of-4 with Axial Blankets” storage configurations over a range of initial enrichment values up to 5.0 w/o ^{235}U and assembly-average burnups up to 45,000 MWd/MTU. When evaluating the biases and uncertainties as described in Section 4.2, a fuel enrichment of 1.47 w/o ^{235}U is utilized for most calculations. The biases and uncertainties for this storage configuration, with the exception of enrichment tolerance and burnup measurement uncertainty, are given in Table 4-6. The enrichment tolerance and burnup measurement uncertainty are given in Table 4-15 at each initial enrichment considered for this storage configuration.

Since this configuration contains axial blankets, the enrichment will be restricted to greater than or equal to 3.0 w/o ^{235}U . At an enrichment of 3.0 w/o ^{235}U , the sum of the biases and uncertainties is determined to be 0.01623 Δk_{eff} units, which results in a target k_{eff} value of 0.97877 (0.995 – 0.01623). Table 4-15 also lists the sum of the biases and uncertainties and the final target k_{eff} values for depleted fuel with 4.0, and 5.0 w/o ^{235}U initial enrichments.

Table 4-24 lists the k_{eff} values for the “3-out-of-4 with Axial Blankets” storage configuration versus initial enrichment and assembly-average burnups. The derived burnup limits, for enrichments greater than or equal to 3.0 w/o ^{235}U , are based on the target k_{eff} values for 3.0, 4.0, and 5.0 w/o ^{235}U from Table 4-15. At each initial enrichment, KENO calculations are performed at three assembly-average burnup values with an axially uniform burnup profile. The k_{eff} values are used to create a second degree fit of the burnup versus k_{eff} data, which were then used to determine the burnup required to meet the target k_{eff} values at each enrichment.

The resulting minimum required burnup versus initial enrichment storage limits for 0 through 20 years of decay time, in 5 year increments, are provided in Table 5-8. The limiting burnups as a function of initial enrichment were fit to second degree polynomials. These polynomials are given below Table 5-8 and will be used to determine the burnup as a function of initial enrichment of the “3-out-of-4 with Axial Blankets” configuration. The data in Table 5-8 are plotted in Figure 5-14.

4.3.9 “2-out-of-4” Storage Configuration

As described in Section 4.1.7, the “2-out-of-4” storage configuration consists of a repeating 2x2 array of storage cells that contain two fuel assemblies in diagonal storage cells.

The k_{eff} values are calculated for an infinite array of “2-out-of-4” storage configurations over a range of initial enrichment values up to 5.0 w/o ^{235}U and assembly-average burnups up to 10,000 MWd/MTU. When evaluating the biases and uncertainties as described in Section 4.2, a fuel enrichment of 3.67 w/o ^{235}U is utilized for most calculations. The biases and uncertainties for this storage configuration, with the exception of enrichment tolerance and burnup measurement uncertainty, are given in Table 4-7. The enrichment tolerance and burnup measurement uncertainty are given in Table 4-16 at each initial enrichment considered for this storage configuration.

At the maximum allowable fresh fuel initial enrichment, the sum of the biases and uncertainties is determined to be 0.01962 Δk_{eff} units, which results in a target k_{eff} value of 0.97538 (0.995 –

0.01962) for fresh fuel. Table 4-16 also lists the sum of the biases and uncertainties and the final target k_{eff} values for depleted fuel with 4.0 and 5.0 w/o ^{235}U initial enrichments.

Table 4-25 lists the k_{eff} values for the “2-out-of-4” storage configuration versus initial enrichment and assembly-average burnups. The first entry Table 4-25 lists the initial enrichment for zero burnup. Based on the target k_{eff} value of 0.97538, the fresh enrichment for zero burnup is 3.67 w/o ^{235}U . The derived burnup limits, for enrichments greater than 3.67 w/o ^{235}U , are based on the target k_{eff} values for 4.0 and 5.0 w/o ^{235}U from Table 4-16. At each initial enrichment, KENO calculations are performed at three assembly-average burnup values with an axially uniform and distributed burnup profile. The largest k_{eff} values from the two profiles are used to create a second degree fit of the burnup versus k_{eff} data, which were then used to determine the burnup required to meet the target k_{eff} values at each enrichment.

The resulting minimum required burnup versus initial enrichment storage limits are provided in Table 5-9. The limiting burnups as a function of initial enrichment were fit to a second degree polynomial. This polynomial is given below Table 5-9 and will be used to determine the burnup as a function of initial enrichment of the “2-out-of-4” configuration. The data in Table 5-9 are plotted in Figure 5-15.

4.4 “Oversize Inspection Cell” Storage Configurations

As described in Section 4.1.8, the modeling of the oversize inspection cell consists of a cuboid of water containing a single cell replacing a 2x2 area in the “4-out-of-4” storage configuration.

The reactivity of the oversize inspection cell is determined in the center of a module with the remainder of the pool filled with 1.02 w/o ^{235}U assemblies. A 5.0 w/o ^{235}U OFA assembly type is the limiting assembly type inside the inspection cell.

The nominal k_{eff} values for the “4-out-of-4” configuration models are shown in Table 4-26 both with and without the oversized inspection cell. These results show that the oversized inspection cell model is less reactive than the design basis fuel assemblies in this storage configuration. The “4-out-of-4” configuration is most limiting because there are no empty cells or poison inserts along the interface with the inspection cell. Therefore, fresh and depleted fuel assemblies may reside in the oversized inspection cell in all regions of the Comanche Peak Units 1 and 2 spent fuel pool.

4.5 Entire Spent Fuel Pool KENO Model

Region II of the Comanche Peak Units 1 and 2 spent fuel pool is modeled in KENO as a water cell surrounded by stainless steel lined concrete walls. Separate models are analyzed to consider storage configurations of interest containing fuel assemblies at the desired allowable initial enrichment and burnup. These modules are modeled in accordance with the illustration in Figure 4-9.

The rack modules are conservatively positioned such that the outer faces are touching. This is a conservative assumption relative to the minimum intra-module separation distances specified in Reference 14. The racks are separated from the spent fuel pool walls by the minimum distance. The overall pool dimensions are determined by maintaining these minimum required separations.

The walls and floor of the spent fuel pool are modeled as concrete, 24 inches thick, with a 0.1875 inch thick stainless steel liner. The water extends 12 inches above the top of the fuel assemblies, and the bottom of the assemblies is 12 inches above the floor of the pool.

The spent fuel pool water is simulated at full density (1.0 g/cm^3) and at room temperature ($68 \text{ }^\circ\text{F}$). This is a conservative approach because the limiting configuration discussed in Section 4.6.3 is most reactive at these conditions. A KENO3D-produced plot of the spent fuel pool model is shown in Figure 4-9.

4.5.1 Storage Configuration Interface Requirements

The entire spent fuel pool model is used to determine the interface requirements of the storage configurations at the maximum fresh enrichment and zero years of decay time. The northeastern module in the pool is filled with one storage configuration, and another configuration is placed in the remaining 8 modules. Table 4-27 provides the k_{eff} calculated for each unique interface condition. The following restrictions should be noted:

- The RCCA in the “4-out-of-4 with 1 RCCA” storage configuration shall be located along the interface.
- RackSavers in the “4-out-of-4 with 3 RackSavers and Axial Blankets” storage configuration shall be located in both storage cells along the interface.
- The RCCAs and RackSavers shall not be in face adjacent storage locations along the interface of the “4-out-of-4 with 2 RackSavers and Axial Blankets” and the “4-out-of-4 with 2 RCCAs” storage configurations.
- The RackSavers shall be oriented such that the poison is facing the adjacent storage configuration.
- In the “2-out-of-4” storage configuration, assemblies shall not be stored in face adjacent storage locations.
- In the “3-out-of-4” storage configuration, the empty cell shall be in the interface row.

4.6 Soluble Boron Credit

The soluble boron credit methodology utilized here is identical to that followed in Reference 1. The total soluble boron credit requirement is defined as the sum of three quantities:

$$SBC_{TOTAL} = SBC_{95/95} + SBC_{RU} + SBC_{PA}$$

Where,

SBC_{TOTAL} is the total soluble boron credit requirement, in units of ppm,

$SBC_{95/95}$ is the soluble boron requirement to maintain k_{eff} less than or equal to 0.95 with 95% probability at a 95% confidence level, in units of ppm,

SBC_{RU} is the soluble boron requirement accounting for burnup and reactivity uncertainties, in units of ppm,

SBC_{PA} is the soluble boron requirement to maintain k_{eff} less than or equal to 0.95 with 95% probability at a 95% confidence level under postulated accident conditions, in units of ppm.

Each of these terms will be discussed in the following sections. The “4-out-of-4” configuration is presented because it requires the largest total soluble boron concentration.

4.6.1 Soluble Boron Requirement to Maintain k_{eff} Less Than or Equal to 0.95

Table 4-28 contains the KENO-calculated k_{eff} values for the entire spent fuel pool from 0 to 1024 ppm of soluble boron, in increments of 102.4 ppm. These KENO models assume that the pool is filled with the “4-out-of-4” storage configuration containing depleted fuel at 75,729 MWd/MTU with 5.0 w/o ^{235}U initial enrichment. The initial enrichment and burnup chosen to represent the storage configuration is based on minimizing the soluble boron worth. The soluble boron worth decreases as burnup increases; therefore the reactivity worth, Δk_{eff} , of the soluble boron is determined by subtracting the k_{eff} value, for a given soluble boron concentration, from the k_{eff} value for zero soluble boron. The soluble boron concentration and reactivity worth data is then fit to a second degree polynomial, which is shown on the bottom of Table 4-28. This polynomial is then utilized to determine the amount of soluble boron required to reduce k_{eff} by 0.05 Δk_{eff} units, which is 363 ppm assuming 18 w/o ^{10}B .

4.6.2 Soluble Boron Requirement for Burnup Credit Reactivity Uncertainties

The soluble boron credit, in units of ppm, required to account for reactivity uncertainties is determined by converting the uncertainty in fuel assembly reactivity and the uncertainty in absolute fuel burnup values to a soluble boron concentration, in units of ppm, necessary to compensate for these two uncertainties. The first term, uncertainty in fuel assembly reactivity, is calculated by employing a depletion reactivity uncertainty of 0.010 Δk_{eff} units per 30,000 MWd/MTU of burnup (as in Reference 1) and multiplying this value by the maximum amount of

burnup credited in a storage configuration. For this analysis, the maximum amount of burnup credited is 75,729 MWd/MTU for the “4-out-of-4” storage configuration. Therefore, the depletion reactivity uncertainty is $0.02524 \Delta k_{\text{eff}}$.

The uncertainty in absolute fuel burnup value is conservatively calculated as $[\quad]^{a,c}$ of the maximum fuel burnup credited in a storage configuration. The reactivity values are determined by factoring the derivative of reactivity as a function burnup (evaluated at the maximum credited burnup) with the $[\quad]^{a,c}$ burnup uncertainty value. The reactivity change associated with a $[\quad]^{a,c}$ change in burnup for the “4-out-of-4” storage configuration is $0.01416 \Delta k_{\text{eff}}$ units.

The total of the uncertainties in fuel assembly reactivity and burnup effects is $0.03940 \Delta k_{\text{eff}}$ units. By applying the polynomial at the bottom of Table 4-28, the soluble boron concentration necessary to compensate for this reactivity is found to be 280 ppm assuming 18 w/o ^{10}B .

4.6.3 Soluble Boron Required to Mitigate Postulated Accident Effects

The soluble boron concentration, in units of ppm, to mitigate accidents is determined by first surveying all possible events that increase the k_{eff} value of the spent fuel pool. The accident event which produced the largest increase in the spent fuel pool k_{eff} value is used to determine the required soluble boron concentration necessary to mitigate this and all less severe accident events. The list of accident scenarios considered includes:

- Intra-module water gap reduction due to seismic event,
- Spent fuel pool temperature greater than 150°F including partial voiding,
- Dropped fresh fuel assembly on top of the storage racks,
- Misloaded fresh fuel assembly into an incorrect storage rack location, or outside the racks.

The postulated accident scenario involving a reduction in the intramodule water gap is explicitly considered in the spent fuel pool calculations. No credit is taken for the intramodule water gap, therefore this event need not be considered as a postulated accident scenario.

It is possible for the spent fuel pool temperature to increase beyond the nominal range. Pool temperature increases result in negative reactivity insertion. Bulk voiding (boiling) was considered to a water density of less than 0.3 g/cm^3 . This condition further reduces reactivity and is therefore not a limiting accident scenario.

A fuel mishandling event is simulated using the KENO model to assess the possible increase in the k_{eff} value of the spent fuel pool. The fuel mishandling event assumes that a fresh Westinghouse 17x17 OFA fuel assembly, enriched to 5.0 w/o ^{235}U (and no burnable absorbers), is misloaded into a storage rack. This case is simulated with the KENO model $[\quad]^{a,c}$.

It is possible to drop a fresh fuel assembly on top of the spent fuel pool storage racks. In this case the physical separation between the fuel assemblies in the spent fuel pool storage racks and the

assembly lying on top of the racks is sufficient to neutronically decouple the accident. In other words, dropping the fresh fuel assembly on top of the storage racks does not produce a positive reactivity increase. Note that the design of the spent fuel racks and fuel handling equipment is such that it precludes the insertion of a fuel assembly between the rack modules.

The k_{eff} value for the limiting accident scenario described above is 1.08638 ± 0.00023 . Note that the nominal case is developed by filling the pool with the “4-out-of-4” storage configuration and then the accident scenario, as described above, is applied. Note also that both the nominal case and the accident scenario are simulated at a soluble boron concentration of 0 ppm. The nominal k_{eff} value is 0.96907 ± 0.00012 , leading to an accident scenario reactivity increase of 0.11731 Δk_{eff} units. The soluble boron concentration required to mitigate this postulated accident is 964 ppm assuming 18 w/o ^{10}B . These values are determined through direct simulation.

4.6.4 Total Soluble Boron Requirement

Soluble boron in the spent fuel pool coolant is used in this criticality safety analysis to offset the reactivity allowances for calculational uncertainties in modeling, storage rack fabrication tolerances, fuel assembly design tolerances, and postulated accidents. The total soluble boron requirement is defined above.

The magnitude of each soluble boron requirement is shown below.

$$SBC_{95/95} = 363 \text{ ppm}$$

$$SBC_{RU} = 280 \text{ ppm}$$

$$SBC_{PA} = 964 \text{ ppm}$$

$$SBC_{TOTAL} = 1607 \text{ ppm}$$

Therefore, a total of 1607 ppm of soluble boron is required to maintain k_{eff} less than or equal to 0.95 (including all biases and uncertainties) assuming the most limiting single postulated accident. Note that these soluble boron concentrations assume an atomic fraction for ^{10}B equal to 0.1944 (18 w/o).

Table 4-1. "4-out-of-4" and "4-out-of-4 with Axial Blankets" Storage Configuration Biases and Uncertainties k_{eff} Results

a, c

A large, empty rectangular box with a black border, intended for the table content. The box is oriented vertically and occupies most of the page's width and height.

Table 4-2. "4-out-of-4 with 1 RCCA" Storage Configuration Biases and Uncertainties
 k_{eff} Results

	a, c

Table 4-3. "4-out-of-4 with 2 RCCAs" Storage Configuration Biases and Uncertainties
 k_{eff} Results

	a, c

Table 4-4. "4-out-of-4 with 2 RackSavers and Axial Blankets" Storage Configuration Biases and Uncertainties k_{eff} Results

a, c

A large, empty rectangular frame with a thin black border, spanning most of the width and height of the page. It appears to be a placeholder for a table or a large figure that has not been rendered.

Table 4-5. "4-out-of-4 with 3 RackSavers and Axial Blankets" Storage Configuration Biases and Uncertainties k_{eff} Results

a, c

A large, empty rectangular frame with a thin black border, intended for a table. The frame is oriented vertically and occupies most of the page's width and height.

Table 4-6. "3-out-of-4" and "3-out-of-4 with Axial Blankets" Storage Configuration Biases and Uncertainties k_{eff} Results

	a, c
--	------

Table 4-7. "2-out-of-4" Storage Configuration Biases and Uncertainties k_{eff} Results

a, c

--	--

Table 4-8. "4-out-of-4" Storage Configuration Total Biases and Uncertainties Results

a, c

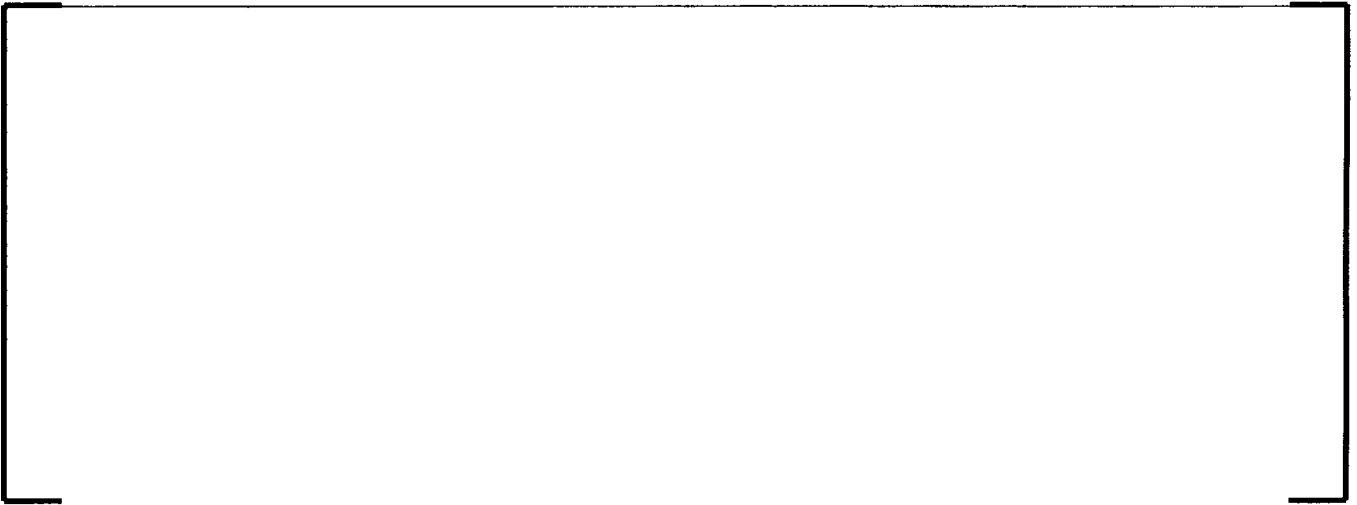

Table 4-9. "4-out-of-4 with Axial Blankets" Storage Configuration Total Biases and Uncertainties Results

	a, c

Table 4-10. "4-out-of-4 with 1 RCCA" Storage Configuration Total Biases and Uncertainties Results

a, c

A large, empty rectangular frame with a thin black border, spanning most of the width and height of the page. It appears to be a placeholder for a table or a large figure that has not been rendered.

Table 4-11. "4-out-of-4 with 2 RCCAs" Storage Configuration Total Biases and Uncertainties Results

a, c

A large, empty rectangular frame with a thin black border, spanning most of the width and height of the page. It appears to be a placeholder for a table or data that is not present in this version of the document.

Table 4-12. "4-out-of-4 with 2 RackSavers and Axial Blankets" Storage Configuration Total Biases and Uncertainties Results

a, c

A large, empty rectangular frame with a thin black border, spanning most of the width and height of the page. It appears to be a placeholder for a table or data that is not present in this version of the document.

Table 4-13. "4-out-of-4 with 3 RackSavers and Axial Blankets" Storage Configuration Total Biases and Uncertainties Results

a, c

A large, empty rectangular frame with a thin black border, spanning most of the width and height of the page. It appears to be a placeholder for a table or a large figure that is not present in this version of the document.

Table 4-14. "3-out-of-4" Storage Configuration Total Biases and Uncertainties Results

a, c

A large, empty rectangular frame with a thin black border, spanning most of the width and height of the page. It appears to be a placeholder for a table or a large figure that is not present in this version of the document.

Table 4-15. "3-out-of-4 with Axial Blankets" Storage Configuration Total Biases and Uncertainties Results

a, c

A large, empty rectangular frame with a thin black border, spanning most of the width and height of the page. It appears to be a placeholder for a table or a large figure that has not been rendered.

Table 4-16. "2-out-of-4" Storage Configuration Total Biases and Uncertainties Results

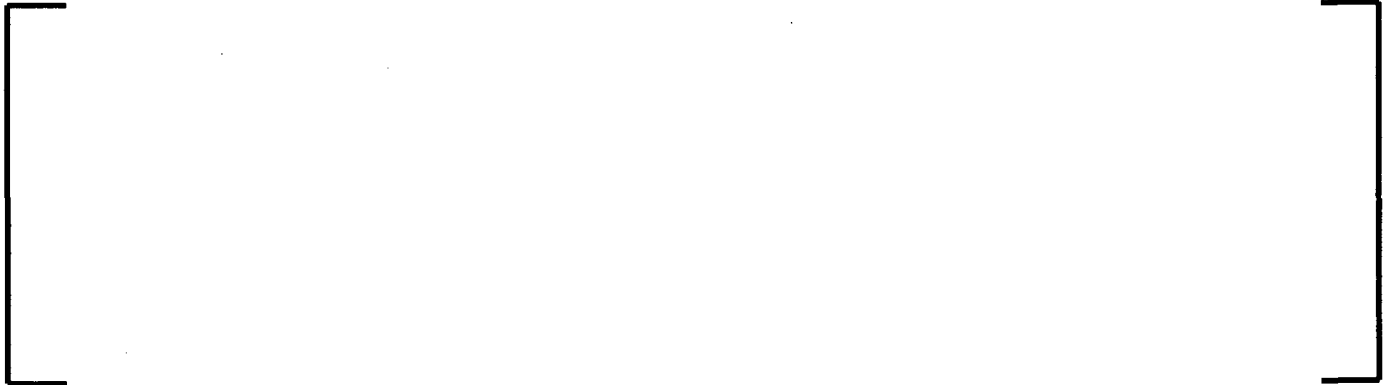

The table content is redacted, represented by a large empty rectangular frame with brackets on the left and right sides.

a, c

Table 4-17. Limiting k_{eff} Values versus Initial ^{235}U Enrichment, Assembly Burnup and Decay Time for the “4-out-of-4” Storage Configuration

Initial Enrichment (w/o ^{235}U)	Assembly Burnup (MWd/MTU)	k_{eff} Results				
		0 yr decay	5 yr decay	10 yr decay	15 yr decay	20 yr decay
1.02	0	0.97020 ± 0.00024	0.97020 ± 0.00024	0.97020 ± 0.00024	0.97020 ± 0.00024	0.97020 ± 0.00024
2.0	15,000	---	---	---	1.01998 ± 0.00027	1.01533 ± 0.00028
2.0	20,000	1.01125 ± 0.00026	0.99480 ± 0.00025	0.98278 ± 0.00030	0.97337 ± 0.00027	0.96664 ± 0.00027
2.0	25,000	0.97860 ± 0.00027	0.95873 ± 0.00024	0.94438 ± 0.00031	0.93284 ± 0.00027	0.92390 ± 0.00028
2.0	30,000	0.95066 ± 0.00032	0.92838 ± 0.00028	0.91132 ± 0.00027	---	---
3.0	30,000	---	---	1.02171 ± 0.00030	1.01182 ± 0.00031	1.00453 ± 0.00028
3.0	35,000	---	1.00251 ± 0.00026	0.98807 ± 0.00026	0.97755 ± 0.00026	0.96842 ± 0.00030
3.0	40,000	0.99383 ± 0.00028	0.97304 ± 0.00027	0.95727 ± 0.00027	0.94443 ± 0.00026	0.93534 ± 0.00029
3.0	45,000	0.96955 ± 0.00027	0.94635 ± 0.00025	---	---	---
3.0	50,000	0.94654 ± 0.00028	---	---	---	---
4.0	45,000	---	---	1.01430 ± 0.00031	1.00331 ± 0.00030	0.99495 ± 0.00031
4.0	50,000	---	1.00215 ± 0.00031	0.98697 ± 0.00027	0.97502 ± 0.00031	0.96613 ± 0.00028
4.0	55,000	0.99896 ± 0.00031	0.97694 ± 0.00029	0.96092 ± 0.00029	0.94791 ± 0.00028	0.93769 ± 0.00029
4.0	60,000	0.97671 ± 0.00029	0.95385 ± 0.00030	---	---	---
4.0	65,000	0.95539 ± 0.00029	---	---	---	---
5.0	55,000	---	---	---	---	1.01157 ± 0.00026
5.0	60,000	---	---	1.00671 ± 0.00031	0.99499 ± 0.00028	0.98572 ± 0.00029
5.0	65,000	---	0.99797 ± 0.00026	0.98186 ± 0.00027	0.96942 ± 0.00028	0.96065 ± 0.00028
5.0	70,000	0.99860 ± 0.00028	0.97660 ± 0.00031	0.95931 ± 0.00029	0.94622 ± 0.00030	---
5.0	75,000	0.97738 ± 0.00031	0.95460 ± 0.00026	---	---	---
5.0	80,000	0.96015 ± 0.00030	---	---	---	---

Table 4-18. Limiting k_{eff} Values versus Initial ^{235}U Enrichment, Assembly Burnup and Decay Time for the "4-out-of-4 with Axial Blankets" Storage Configuration

Initial Enrichment (w/o ^{235}U)	Assembly Burnup (MWd/MTU)	k_{eff} Results				
		0 yr decay	5 yr decay	10 yr decay	15 yr decay	20 yr decay
3.0	25,000	---	---	1.04317 ± 0.00022	1.03211 ± 0.00026	1.02293 ± 0.00025
3.0	30,000	---	1.01349 ± 0.00024	0.99567 ± 0.00023	0.98170 ± 0.00022	0.97000 ± 0.00024
3.0	35,000	0.99903 ± 0.00023	0.97316 ± 0.00022	0.95262 ± 0.00021	0.93602 ± 0.00022	0.92341 ± 0.00022
3.0	40,000	0.96517 ± 0.00025	0.93620 ± 0.00022	---	---	---
3.0	45,000	0.93471 ± 0.00023	---	---	---	---
4.0	35,000	---	---	---	1.03367 ± 0.00022	1.02390 ± 0.00025
4.0	40,000	---	---	1.00381 ± 0.00022	0.98905 ± 0.00026	0.97653 ± 0.00024
4.0	45,000	1.01223 ± 0.00022	0.98544 ± 0.00024	0.96406 ± 0.00022	0.94682 ± 0.00022	0.93377 ± 0.00022
4.0	50,000	0.97956 ± 0.00021	0.94961 ± 0.00021	0.92603 ± 0.00021	---	---
4.0	55,000	0.94883 ± 0.00023	0.91737 ± 0.00022	---	---	---
5.0	45,000	---	---	---	1.02929 ± 0.00023	1.01834 ± 0.00027
5.0	50,000	---	---	1.00522 ± 0.00022	0.98884 ± 0.00023	0.97692 ± 0.00023
5.0	55,000	---	0.99059 ± 0.00021	0.96858 ± 0.00024	0.95047 ± 0.00024	0.93734 ± 0.00021
5.0	60,000	0.98679 ± 0.00024	0.95654 ± 0.00023	0.93331 ± 0.00022	---	---
5.0	65,000	0.95758 ± 0.00023	0.92566 ± 0.00021	---	---	---
5.0	70,000	0.92987 ± 0.00023	---	---	---	---

Table 4-19. Limiting k_{eff} Values versus Initial ^{235}U Enrichment and Assembly-Average Burnup for the "4-out-of-4 with 1 RCCA" Storage Configuration

Initial Enrichment (w/o ^{235}U)	Assembly Burnup (MWd/MTU)	k_{eff} Value	
		0 yr decay	10 yr decay
1.20	0	0.97173 ± 0.00029	0.97173 ± 0.00029
2.0	10,000	1.04363 ± 0.00027	1.03044 ± 0.00029
2.0	15,000	0.99766 ± 0.00029	0.97450 ± 0.00025
2.0	20,000	0.95898 ± 0.00025	0.93043 ± 0.00030
2.0	25,000	0.92774 ± 0.00030	---
3.0	25,000	---	1.00654 ± 0.00038
3.0	30,000	0.99829 ± 0.00028	0.97080 ± 0.00030
3.0	35,000	0.97164 ± 0.00034	0.94118 ± 0.00034
3.0	40,000	0.94557 ± 0.00028	---
3.0	45,000	0.92249 ± 0.00029	---
4.0	40,000	---	0.99555 ± 0.00028
4.0	45,000	0.99845 ± 0.00033	0.96829 ± 0.00031
4.0	50,000	0.97522 ± 0.00029	0.94167 ± 0.00033
4.0	55,000	0.95297 ± 0.00032	---
4.0	60,000	0.93283 ± 0.00031	---
5.0	50,000	---	1.01087 ± 0.00033
5.0	55,000	1.01618 ± 0.00029	0.98669 ± 0.00033
5.0	60,000	0.99506 ± 0.00035	0.96298 ± 0.00033
5.0	65,000	0.97503 ± 0.00030	---
5.0	70,000	0.95545 ± 0.00031	---

Table 4-20. Limiting k_{eff} Values versus Initial ^{235}U Enrichment and Assembly-Average Burnup for the "4-out-of-4 with 2 RCCAs" Storage Configuration

Initial Enrichment (w/o ^{235}U)	Assembly Burnup (MWd/MTU)	k_{eff} Value	
		0 yr decay	10 yr decay
1.53	0	0.97775 ± 0.00014	0.97775 ± 0.00014
2.0	5,000	1.01818 ± 0.00029	1.01489 ± 0.00029
2.0	10,000	0.97364 ± 0.00030	0.96179 ± 0.00030
2.0	15,000	0.93236 ± 0.00027	0.90998 ± 0.00028
2.0	20,000	0.89682 ± 0.00027	---
3.0	15,000	1.04320 ± 0.00029	1.02897 ± 0.00028
3.0	20,000	1.00334 ± 0.00028	0.98421 ± 0.00030
3.0	25,000	0.96819 ± 0.00031	0.94678 ± 0.00033
3.0	30,000	0.93804 ± 0.00030	---
4.0	30,000	1.01841 ± 0.00029	1.00023 ± 0.00032
4.0	35,000	0.99127 ± 0.00032	0.96840 ± 0.00032
4.0	40,000	0.96525 ± 0.00032	0.94004 ± 0.00029
4.0	45,000	0.94272 ± 0.00027	---
5.0	45,000	1.00522 ± 0.00029	1.00852 ± 0.00033
5.0	50,000	0.98375 ± 0.00035	0.98239 ± 0.00030
5.0	55,000	0.96246 ± 0.00035	0.95733 ± 0.00031
5.0	60,000	0.94229 ± 0.00034	---

Table 4-21. Limiting k_{eff} Values versus Initial ^{235}U Enrichment and Assembly-Average Burnup for the “4-out-of-4 with 2 RackSavers and Axial Blankets” Storage Configuration

Initial Enrichment (w/o ^{235}U)	Assembly Burnup (MWd/MTU)	k_{eff} Value
3.0	15,000	1.05886 ± 0.00029
3.0	20,000	1.01770 ± 0.00028
3.0	25,000	0.98003 ± 0.00027
3.0	30,000	0.94302 ± 0.00026
4.0	30,000	1.02451 ± 0.00028
4.0	35,000	0.99035 ± 0.00028
4.0	40,000	0.95675 ± 0.00025
4.0	45,000	0.92525 ± 0.00027
5.0	45,000	0.99326 ± 0.00028
5.0	50,000	0.96261 ± 0.00028
5.0	55,000	0.93259 ± 0.00026
5.0	60,000	0.90339 ± 0.00025

Table 4-22. Limiting k_{eff} Values versus Initial ^{235}U Enrichment and Assembly-Average Burnup for the “4-out-of-4 with 3 RackSavers and Axial Blankets” Storage Configuration

Initial Enrichment (w/o ^{235}U)	Assembly Burnup (MWd/MTU)	k_{eff} Value
3.0	10,000	1.05103 ± 0.00032
3.0	15,000	1.00928 ± 0.00034
3.0	20,000	0.96993 ± 0.00032
3.0	25,000	0.93301 ± 0.00029
4.0	25,000	1.01254 ± 0.00030
4.0	30,000	0.97843 ± 0.00028
4.0	35,000	0.94504 ± 0.00028
4.0	40,000	0.91383 ± 0.00030
5.0	30,000	1.04221 ± 0.00029
5.0	35,000	1.01050 ± 0.00030
5.0	40,000	0.97991 ± 0.00029
5.0	45,000	0.94960 ± 0.00027

Table 4-23. Limiting k_{eff} Values versus Initial ^{235}U Enrichment, Assembly Burnup and Decay Time for the “3-out-of-4” Storage Configuration

Initial Enrichment (w/o ^{235}U)	Assembly Burnup (MWd/MTU)	k_{eff} Results				
		0 yr decay	5 yr decay	10 yr decay	15 yr decay	20 yr decay
1.47	0	0.97670 ± 0.00030	0.97670 ± 0.00030	0.97670 ± 0.00030	0.97670 ± 0.00030	0.97670 ± 0.00030
2.0	5,000	1.01480 ± 0.00033	1.01330 ± 0.00031	1.01150 ± 0.00033	1.01147 ± 0.00032	1.00961 ± 0.00031
2.0	10,000	0.96791 ± 0.00033	0.96102 ± 0.00030	0.95633 ± 0.00029	0.95276 ± 0.00030	0.94847 ± 0.00029
2.0	15,000	0.92554 ± 0.00034	0.91415 ± 0.00030	0.90579 ± 0.00031	0.90125 ± 0.00032	0.89599 ± 0.00030
3.0	15,000	---	1.02033 ± 0.00033	1.01437 ± 0.00033	1.00965 ± 0.00030	1.00684 ± 0.00035
3.0	20,000	0.98965 ± 0.00030	0.98003 ± 0.00032	0.97311 ± 0.00031	0.96762 ± 0.00030	0.96360 ± 0.00033
3.0	25,000	0.95793 ± 0.00034	0.94599 ± 0.00039	0.93734 ± 0.00033	0.93075 ± 0.00032	0.92542 ± 0.00032
3.0	30,000	0.92890 ± 0.00034	---	---	---	---
4.0	25,000	---	---	1.01512 ± 0.00033	1.01120 ± 0.00033	1.00712 ± 0.00037
4.0	30,000	1.00220 ± 0.00035	0.99100 ± 0.00034	0.98298 ± 0.00037	0.97754 ± 0.00035	0.97231 ± 0.00036
4.0	35,000	0.97571 ± 0.00032	0.96297 ± 0.00032	0.95349 ± 0.00034	0.94594 ± 0.00033	0.94044 ± 0.00033
4.0	40,000	0.95104 ± 0.00034	0.93685 ± 0.00028	---	---	---
5.0	35,000	---	---	---	1.01228 ± 0.00033	1.00796 ± 0.00036
5.0	40,000	1.00932 ± 0.00036	0.99793 ± 0.00035	0.98985 ± 0.00032	0.98348 ± 0.00035	0.97816 ± 0.00034
5.0	45,000	0.98528 ± 0.00032	0.97292 ± 0.00034	0.96340 ± 0.00036	0.95657 ± 0.00032	0.95070 ± 0.00042
5.0	50,000	0.96380 ± 0.00033	0.94984 ± 0.00032	0.93854 ± 0.00032	---	---

Table 4-24. Limiting k_{eff} Values versus Initial ^{235}U Enrichment, Assembly Burnup and Decay Time for the “3-out-of-4 with Axial Blankets” Storage Configuration

Initial Enrichment (w/o ^{235}U)	Assembly Burnup (MWd/MTU)	k_{eff} Results				
		0 yr decay	5 yr decay	10 yr decay	15 yr decay	20 yr decay
3.0	15,000	1.02769 ± 0.00031	1.02033 ± 0.00033	1.01401 ± 0.00033	1.00938 ± 0.00032	1.00646 ± 0.00031
3.0	20,000	0.98794 ± 0.00033	0.97592 ± 0.00030	0.96683 ± 0.00027	0.95966 ± 0.00028	0.95323 ± 0.00029
3.0	25,000	0.94998 ± 0.00030	0.93410 ± 0.00030	0.92170 ± 0.00027	0.91218 ± 0.00028	0.90443 ± 0.00028
4.0	25,000	---	1.01549 ± 0.00029	1.00619 ± 0.00030	0.99878 ± 0.00031	0.99329 ± 0.00028
4.0	30,000	0.99125 ± 0.00029	0.97710 ± 0.00032	0.96474 ± 0.00027	0.95563 ± 0.00028	0.94818 ± 0.00027
4.0	35,000	0.95790 ± 0.00028	0.94030 ± 0.00028	0.92576 ± 0.00029	0.91488 ± 0.00027	0.90545 ± 0.00027
4.0	40,000	0.92546 ± 0.00027	---	---	---	---
5.0	30,000	---	---	---	---	1.02252 ± 0.00031
5.0	35,000	1.02106 ± 0.00031	1.00602 ± 0.00029	0.99517 ± 0.00032	0.98622 ± 0.00032	0.97963 ± 0.00029
5.0	40,000	0.99000 ± 0.00030	0.97270 ± 0.00033	0.95894 ± 0.00029	0.94814 ± 0.00031	0.93980 ± 0.00034
5.0	45,000	0.95911 ± 0.00027	0.93986 ± 0.00027	0.92375 ± 0.00030	0.91135 ± 0.00028	---

Table 4-25. Limiting k_{eff} Values versus Initial ^{235}U Enrichment and Assembly-Average Burnup for the “2-out-of-4” Storage Configuration

Initial Enrichment (w/o ^{235}U)	Assembly Burnup (MWd/MTU)	k_{eff} Value
3.67	0	0.97528 ± 0.00039
4.0	0	0.99232 ± 0.00040
4.0	5,000	0.94483 ± 0.00036
4.0	10,000	0.90994 ± 0.00039
5.0	0	1.03149 ± 0.00042
5.0	5,000	0.98710 ± 0.00036
5.0	10,000	0.95515 ± 0.00037

Table 4-26. Oversize Inspection Cell k_{eff} Results

Configuration	k_{eff}
"4-out-of-4"	0.97020 ± 0.00024
"4-out-of-4" with Oversize Inspection Cell	0.96945 ± 0.00023

Table 4-27. Entire Spent Fuel Pool k_{eff} Results for the Interface Configurations

	"4-out-of-4"		"3-out-of-4"		"2-out-of-4"		"4-out-of-4 with 1 RCCA"	
	k_{eff}	Limiting Target k_{eff}	k_{eff}	Limiting Target k_{eff}	k_{eff}	Limiting Target k_{eff}	k_{eff}	Limiting Target k_{eff}
"4-out-of-4"								
"3-out-of-4"	0.96928 ± 0.00024	0.97711						
"2-out-of-4"	0.97153 ± 0.00038	0.97538	0.97341 ± 0.00033	0.97711				
"4-out-of-4 with 1 RCCA"	0.96938 ± 0.00023	0.97362	0.97370 ± 0.00033	0.97711	0.97149 ± 0.00042	0.97538		
"4-out-of-4 with 2 RCCAs"	0.97298 ± 0.00029	0.97778	0.97341 ± 0.00032	0.97778	0.97343 ± 0.00040	0.97778	0.97287 ± 0.00029	0.97778
"4-out-of-4 with 2 RackSavers and Axial Blankets"	0.97177 ± 0.00026	0.97568	0.97393 ± 0.00029	0.97711	0.97256 ± 0.00041	0.97568	0.97362 ± 0.00026	0.97568
"4-out-of-4 with 3 RackSavers and Axial Blankets"	0.96930 ± 0.00024	0.97823	0.97357 ± 0.00030	0.97823	0.97127 ± 0.00040	0.97823	0.97314 ± 0.00031	0.97823

Table 4-27 (continued). Entire Spent Fuel Pool k_{eff} Results for the Interface Configurations

	"4-out-of-4 with 2 RCCAs"		"4-out-of-4 with 2 RackSavers and Axial Blankets"		"4-out-of-4 with 3 RackSavers and Axial Blankets"	
	k_{eff}	Limiting Target k_{eff}	k_{eff}	Limiting Target k_{eff}	k_{eff}	Limiting Target k_{eff}
"4-out-of-4"						
"3-out-of-4"						
"2-out-of-4"						
"4-out-of-4 with 1 RCCA"						
"4-out-of-4 with 2 RCCAs"						
"4-out-of-4 with 2 RackSavers and Axial Blankets"	0.97688 ± 0.00032	0.97778				
"4-out-of-4 with 3 RackSavers and Axial Blankets"	0.97625 ± 0.00032	0.97823	0.97453 ± 0.00029	0.97823		

Table 4-28. k_{eff} Values as a Function of Soluble Boron Concentration for the Spent Fuel Pool

Soluble Boron Concentration (ppm)	k_{eff}	Δk_{eff}
0	0.97509 ± 0.00013	---
102	0.96032 ± 0.00014	0.01477
205	0.94585 ± 0.00014	0.02924
307	0.93253 ± 0.00015	0.04256
409	0.91937 ± 0.00013	0.05572
512	0.90700 ± 0.00013	0.06809
614	0.89502 ± 0.00013	0.08007
716	0.88341 ± 0.00013	0.09168
819	0.87276 ± 0.00014	0.10233
921	0.86230 ± 0.00013	0.11279
1024	0.85173 ± 0.00013	0.12336

The soluble boron concentration as a function of Δk_{eff} in the Comanche Peak Units 1 and 2 spent fuel pools is described by the following polynomial:

$$\text{Soluble Boron Concentration (ppm)} = 14007.0\Delta k_{eff}^2 + 6567.0\Delta k_{eff}$$

Table 4-29. Summary of Burnup Reactivity Uncertainties for the Storage Configurations

Configuration	Maximum Credited Burnup (MWd/MTU)	[]^{a,c} Burnup Uncertainty	Δk_{eff}
"4-out-of-4"	75,729	3786	0.01412
"4-out-of-4 with Axial Blankets"	62,662	3133	0.01827
"4-out-of-4 with 1 RCCA"	64,743	3237	0.01277
"4-out-of-4 with 2 RCCAs"	51,378	2569	0.01102
"4-out-of-4 with 2 RackSavers and Axial Blankets"	48,088	2404	0.01471
"4-out-of-4 with 3 RackSavers and Axial Blankets"	40,568	2028	0.01229
"3-out-of-4"	46,669	2333	0.01022
"3-out-of-4 with Axial Blankets"	42,327	2116	0.01308
"2-out-of-4"	6,681	334	0.00227

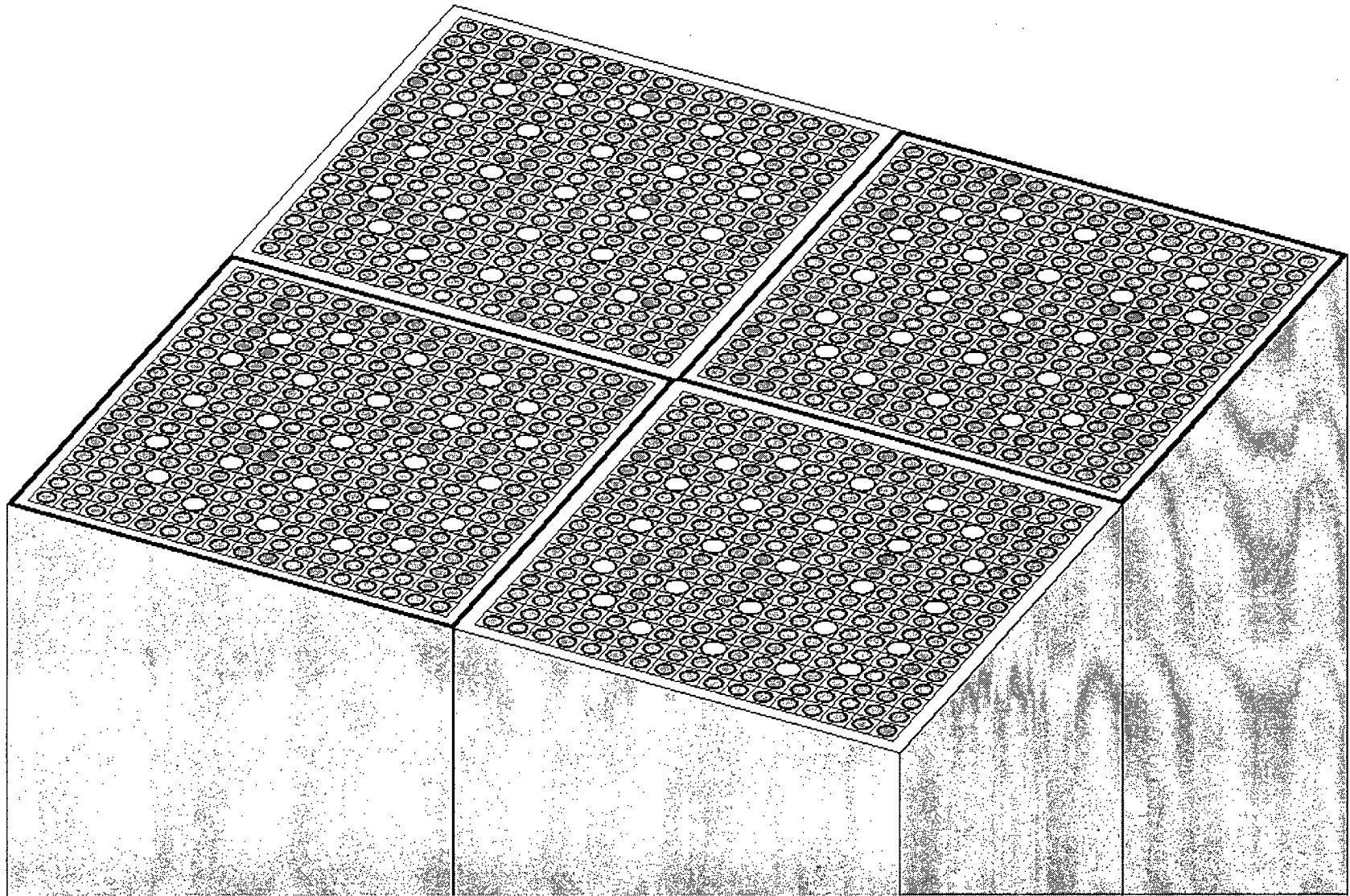

Figure 4-1. KENO3D-Produced Plot of the “4-out-of-4” and “4-out-of-4 with Axial Blankets” Storage Configurations

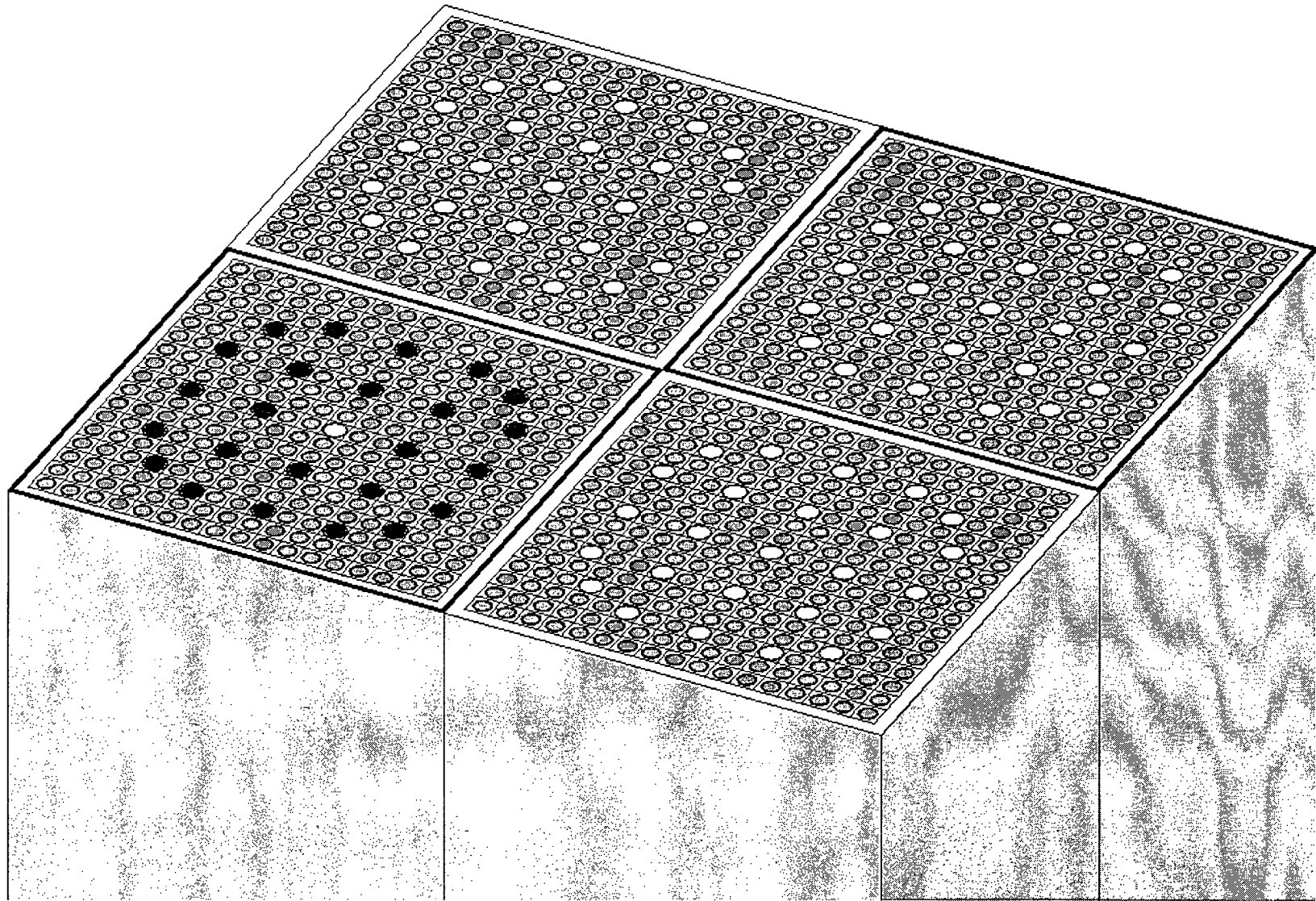

Figure 4-2. KENO3D-Produced Plot of the "4-out-of-4 with 1 RCCA" Storage Configuration

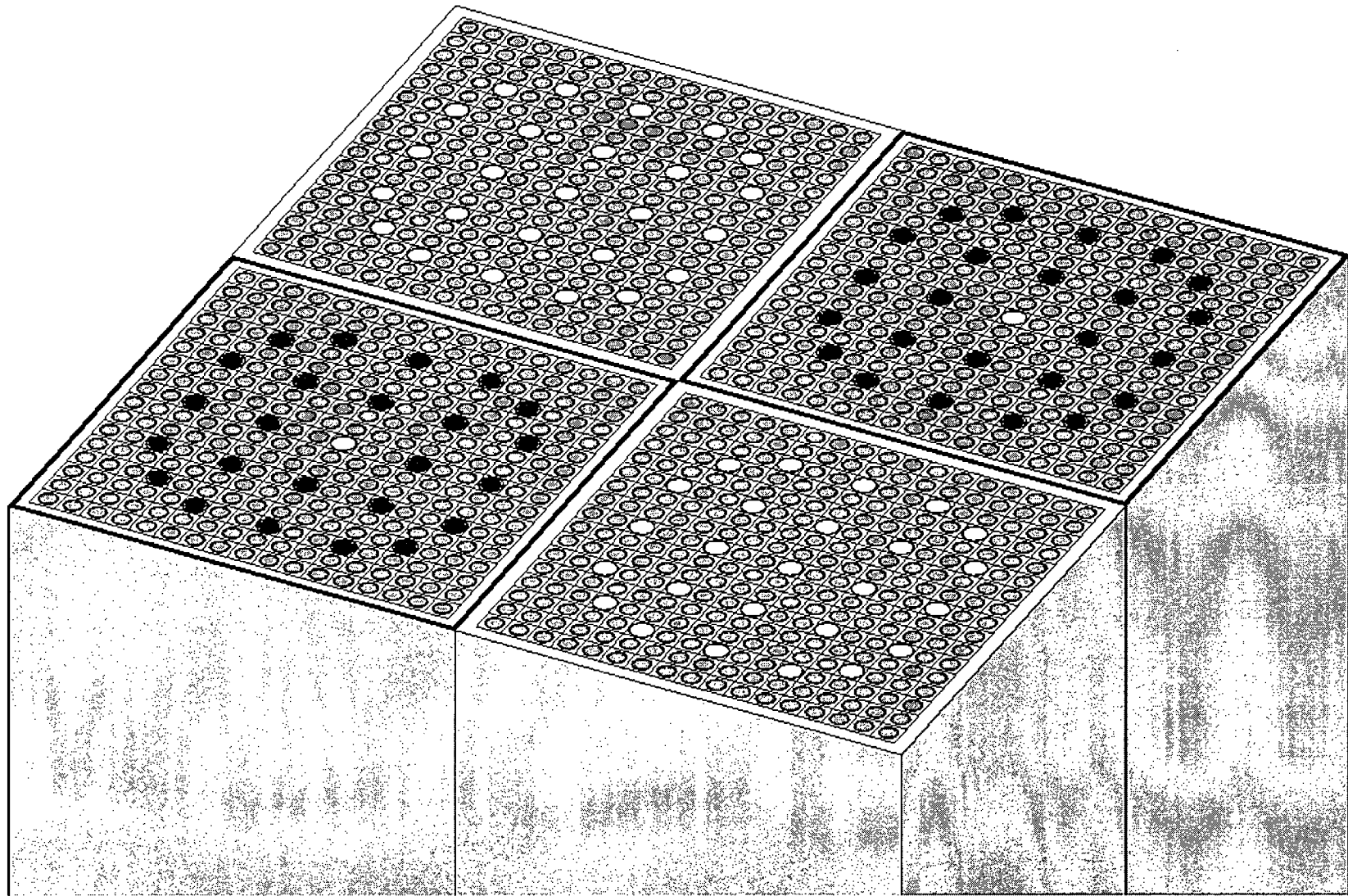

Figure 4-3. KENO3D-Produced Plot of the "4-out-of-4 with 2 RCCAs" Storage Configuration

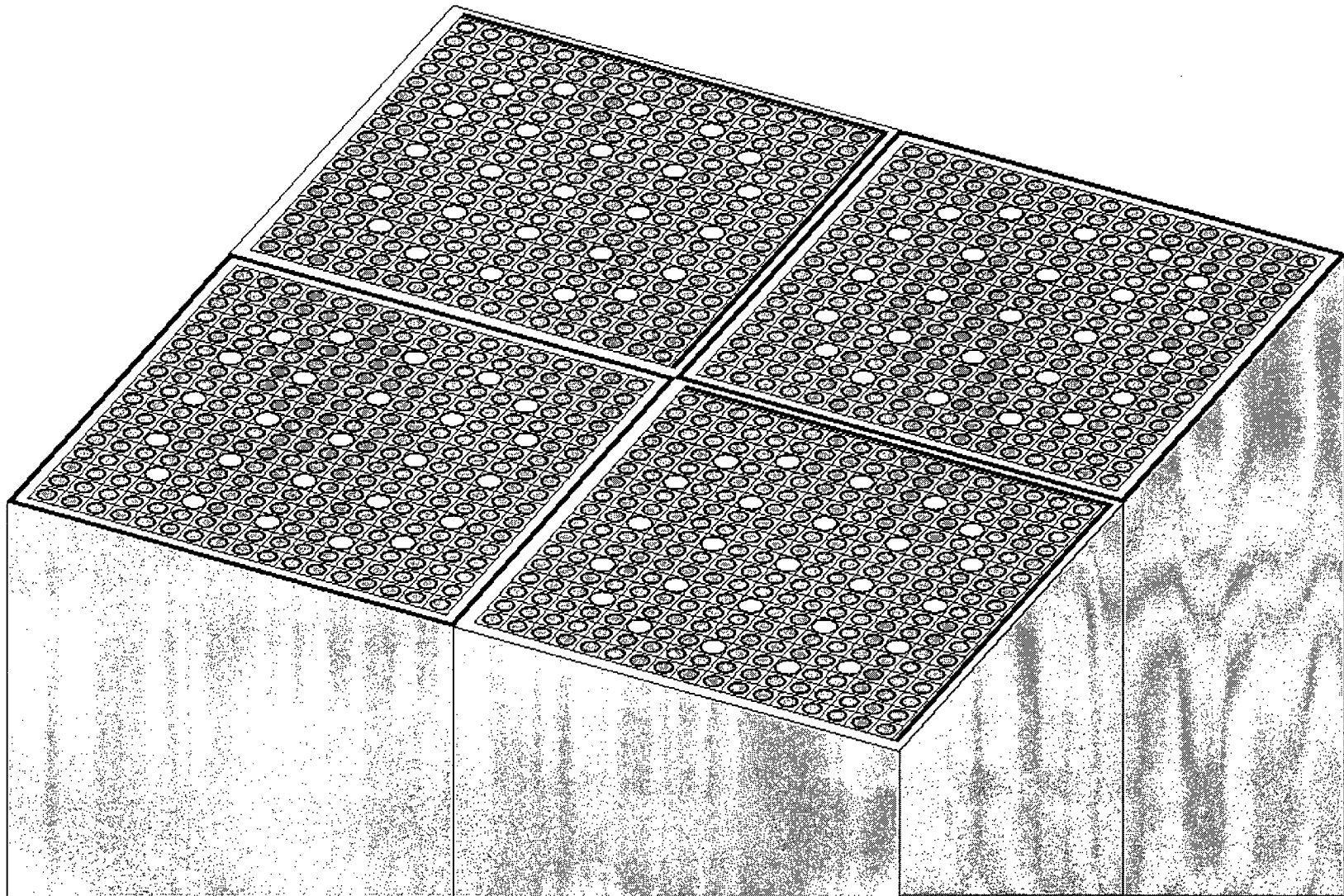

Figure 4-4. KENO3D-Produced Plot of the “4-out-of-4 with 2 RackSavers and Axial Blankets” Storage Configuration

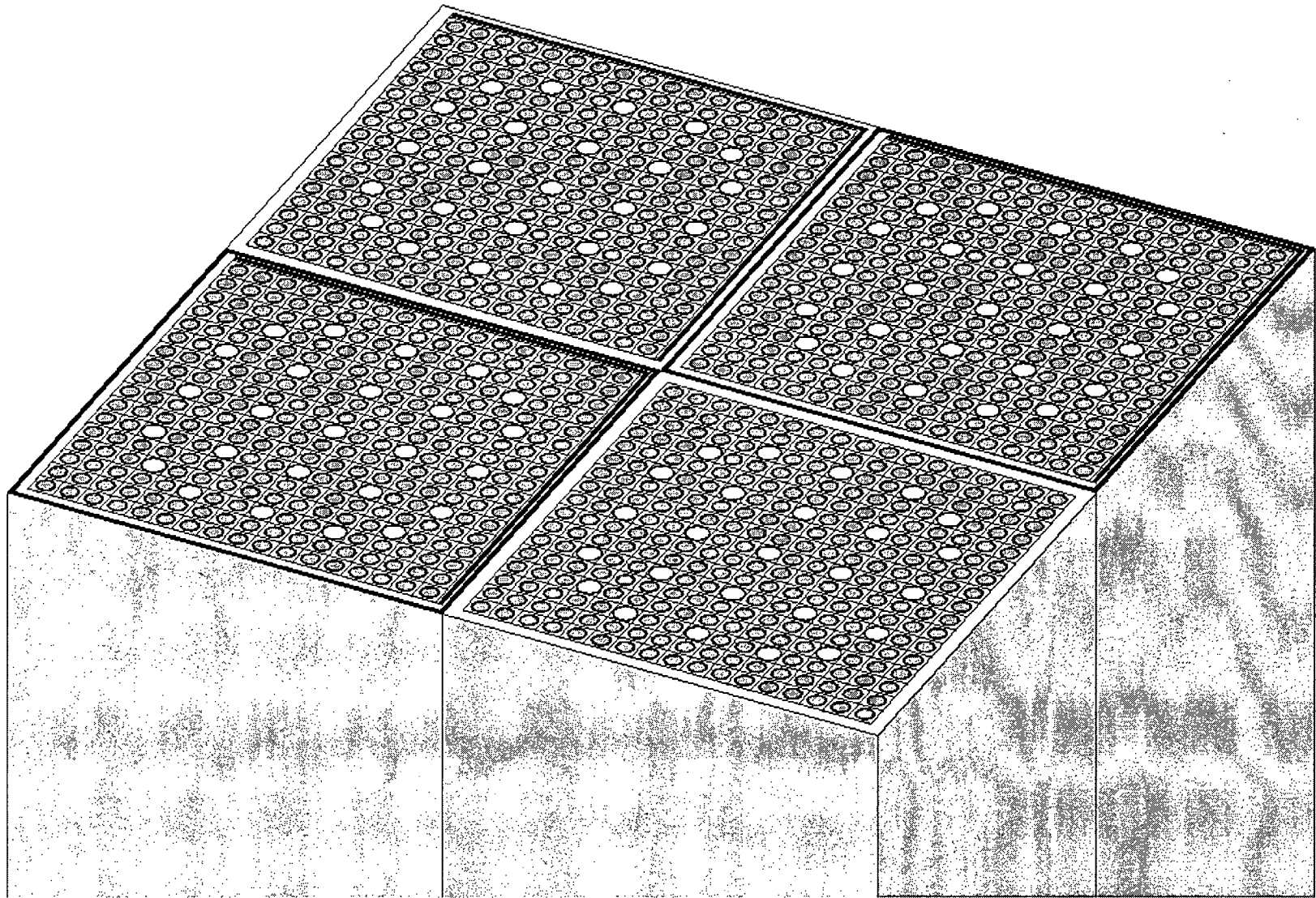

Figure 4-5. KENO3D-Produced Plot of the “4-out-of-4 with 3 RackSavers and Axial Blankets” Storage Configuration

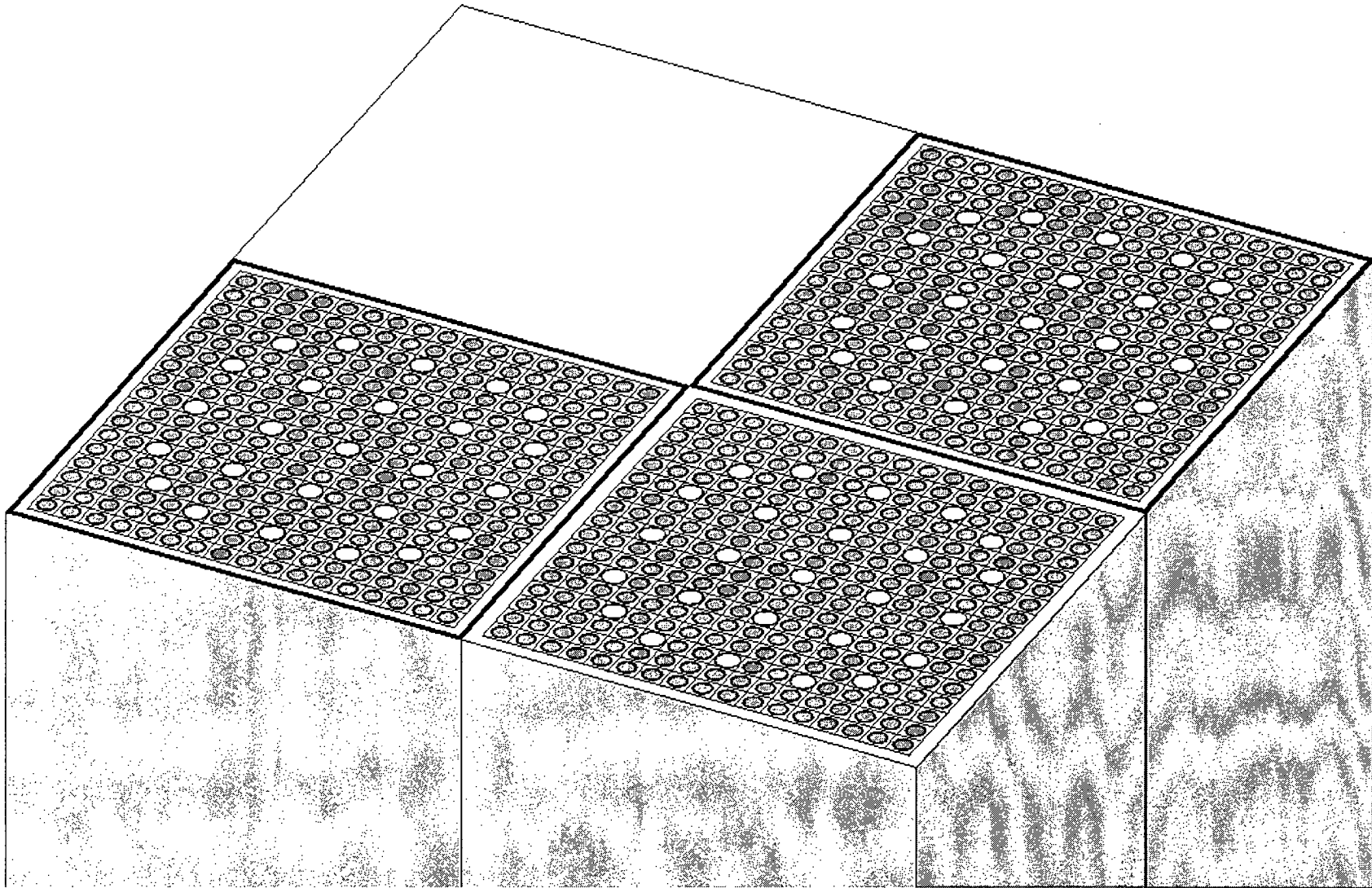

Figure 4-6. KENO3D-Produced Plot of the "3-out-of-4" and "3-out-of-4 with Axial Blankets" Storage Configurations

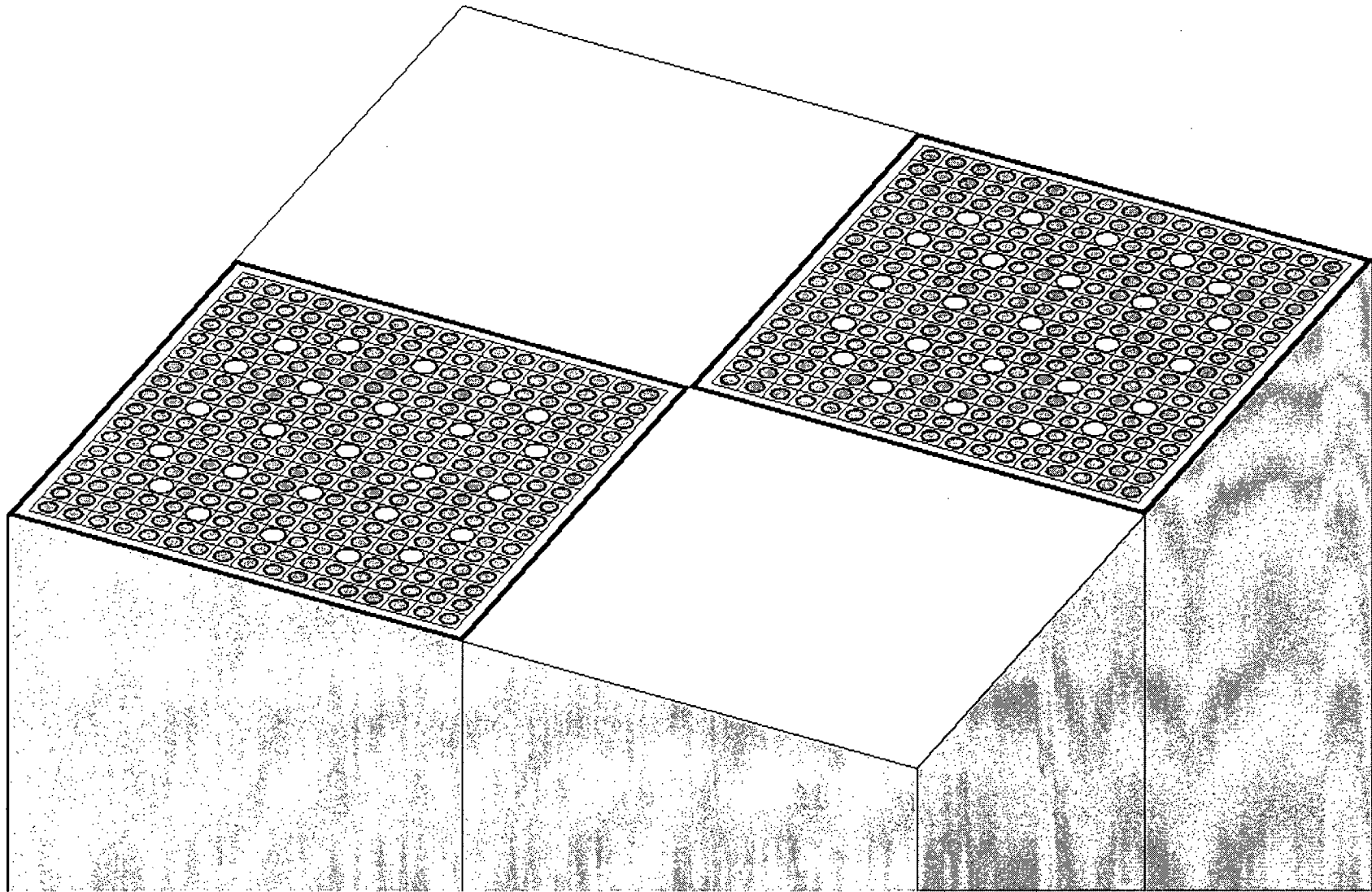

Figure 4-7. KENO3D-Produced Plot of the "2-out-of-4" Storage Configuration

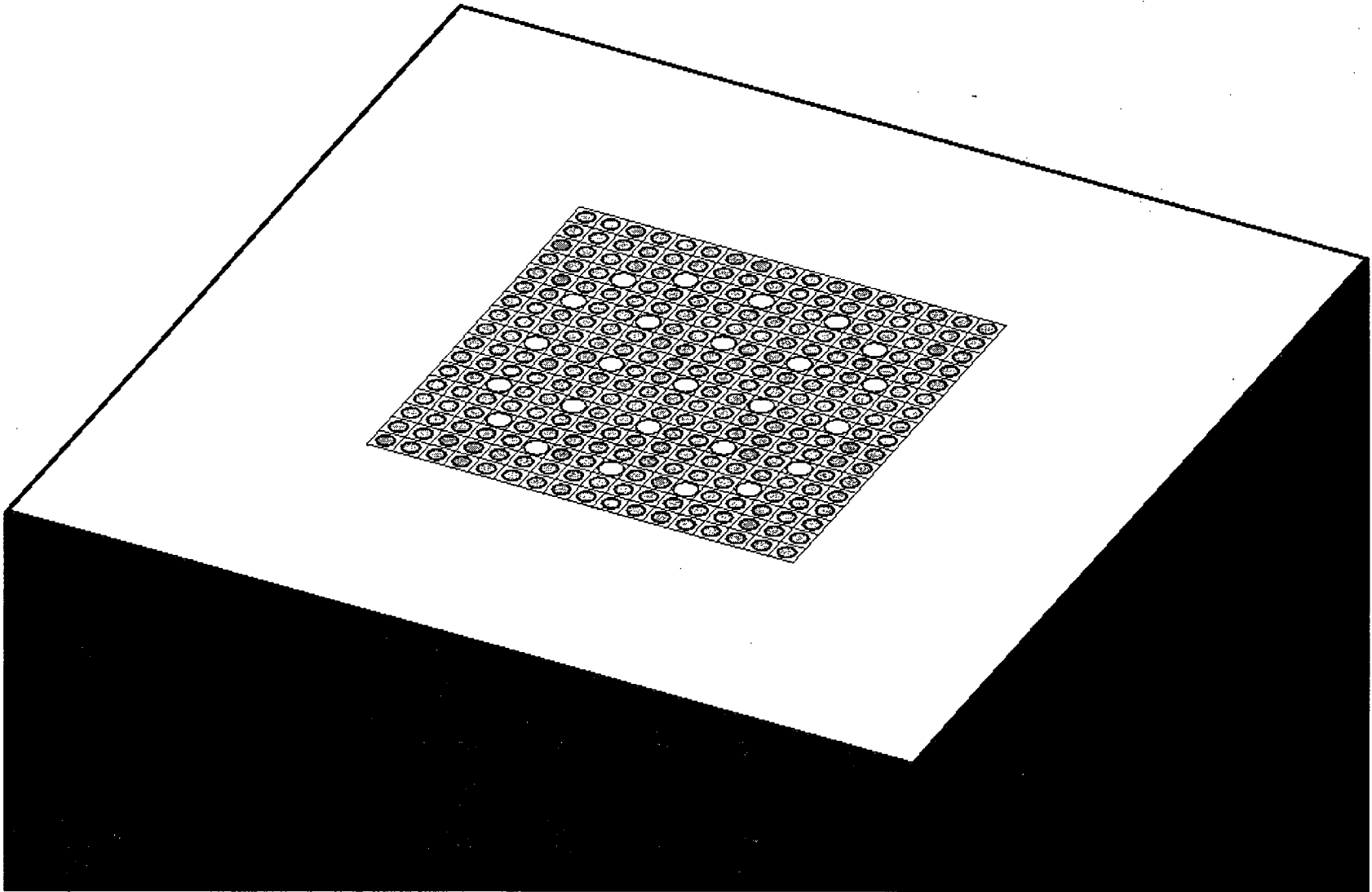

Figure 4-8. KENO3D-Produced Plot of the “Oversize Inspection Cell” Storage Configuration

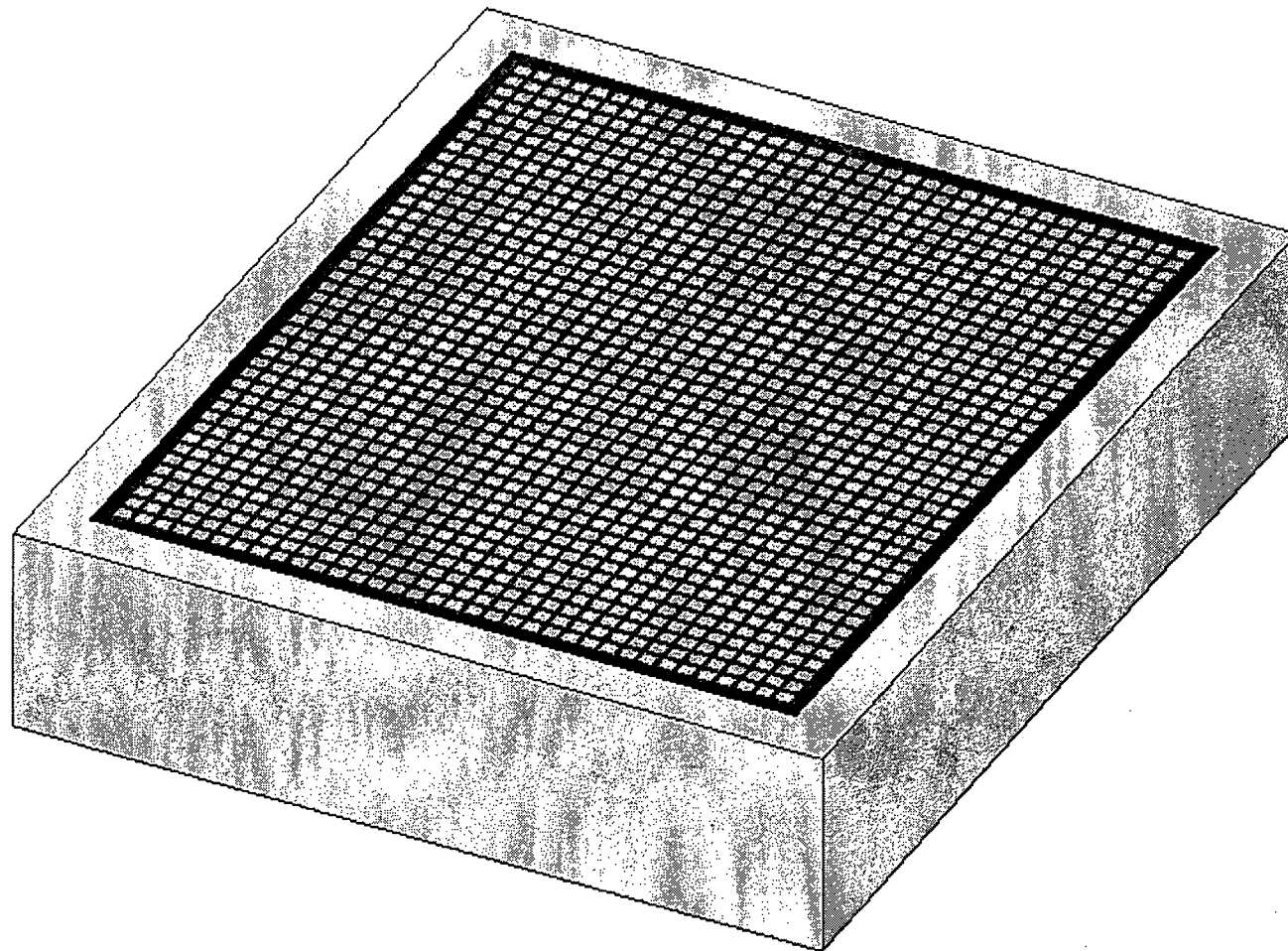

Figure 4-9. KENO3D-Produced Plot of the Entire Spent Fuel Pool Model

“This page intentionally left blank.”

5.0 Summary of Results

This section presents the results of the Comanche Peak Units 1 and 2 spent fuel pool criticality safety analysis with reactivity credit for burnup, RCCAs, RackSaver inserts, axial blankets and ^{241}Pu decay.

Certain storage configurations require fuel assemblies with axial blankets that meet explicit requirements. However, fuel assemblies with axial blankets may be stored in all storage configurations.

5.1 Allowable Fuel Assembly Designs

The Westinghouse STD and OFA designs, along with the Siemens STD and OFA designs, have been conservatively considered in this analysis and may be stored in all Region II storage configurations of the Comanche Peak Units 1 and 2 spent fuel pool. Fuel assemblies with axial blankets may be stored in any storage configuration.

5.2 Allowable Comanche Peak Units 1 and 2 Spent Fuel Pool Storage Configurations

For all storage configurations, non-fissile material may be safely stored in place of a fuel assembly and storage cells may be left empty. The minimum burnup requirements for each storage configuration shall be determined from the polynomial fit to the tabulated data, not by linear interpolation between points.

5.2.1 “4-out-of-4” Storage Configuration

The “4-OUT-OF-4” storage configuration may be employed to store fresh or depleted fuel assemblies that meet the minimum burnup and decay time requirements of Figure 5-7. The minimum burnup and decay time requirements are tabulated as a function of initial enrichment in Table 5-1.

5.2.2 “4-out-of-4 with Axial Blankets” Storage Configuration

The “4-OUT-OF-4 with Axial Blankets” storage configuration may be employed to store fresh or depleted fuel assemblies that meet the minimum burnup and decay time requirements of Figure 5-8. The minimum burnup and decay time requirements are tabulated as a function of initial enrichment in Table 5-2. All assemblies stored in this storage configuration shall have initial enrichments greater than 3.0 w/o ^{235}U and contain axial blankets with a nominal enrichment no greater than 2.60 w/o ^{235}U and nominal length no less than 6 inches.

5.2.3 “4-out-of-4 with 1 RCCA” Storage Configuration

The “4-out-of-4 with 1 RCCA” storage configuration may be employed to store fresh or depleted fuel assemblies in accordance with the storage pattern of Figure 5-1 that meet the minimum burnup and decay time requirements of Figure 5-9. The minimum burnup and decay time requirements are tabulated as a function of initial enrichment in Table 5-3.

5.2.4 “4-out-of-4 with 2 RCCAs” Storage Configuration

The “4-out-of-4 with 2 RCCAs” storage configuration may be employed to store fresh or depleted fuel assemblies in accordance with the storage pattern of Figure 5-2 that meet the minimum burnup and decay time requirements of Figure 5-10. The minimum burnup and decay time requirements are tabulated as a function of initial enrichment in Table 5-4.

5.2.5 “4-out-of-4 with 2 RackSavers and Axial Blankets” Storage Configuration

The “4-out-of-4 with 2 RackSavers and Axial Blankets” storage configuration may be employed to store fresh or depleted fuel assemblies in accordance with the storage pattern of Figure 5-3 that meet the minimum burnup requirements of Figure 5-11. The minimum burnup requirements are tabulated as a function of initial enrichment in Table 5-5. All assemblies stored in this storage configuration shall have initial enrichments greater than 3.0 w/o ^{235}U and contain axial blankets with a nominal enrichment no greater than 2.60 w/o ^{235}U and nominal length no less than 6 inches. The RackSavers shall be oriented in a consistent manner within contiguous storage configurations

5.2.6 “4-out-of-4 with 3 RackSavers and Axial Blankets” Storage Configuration

The “4-out-of-4 with 3 RackSavers and Axial Blankets” storage configuration may be employed to store fresh or depleted fuel assemblies in accordance with the storage pattern of Figure 5-4 that meet the minimum burnup requirements of Figure 5-12. The minimum burnup requirements are tabulated as a function of initial enrichment in Table 5-6. All assemblies stored in this storage configuration shall have initial enrichments greater than 3.0 w/o ^{235}U and contain axial blankets with a nominal enrichment no greater than 2.60 w/o ^{235}U and nominal length no less than 6 inches. The RackSavers shall be oriented in a consistent manner within contiguous storage configurations

5.2.7 “3-out-of-4” Storage Configuration

The “3-OUT-OF-4” storage configuration may be employed to store fresh or depleted fuel assemblies in accordance with the storage pattern of Figure 5-5 that meet the minimum burnup and decay time requirements of Figure 5-13. The minimum burnup and decay time requirements are tabulated as a function of initial enrichment in Table 5-7.

5.2.8 “3-out-of-4 with Axial Blankets” Storage Configuration

The “3-OUT-OF-4 with Axial Blankets” storage configuration may be employed to store fresh or depleted fuel assemblies in accordance with the storage pattern of Figure 5-5 that meet the minimum burnup and decay time requirements of Figure 5-14. All assemblies stored in this storage configuration shall have initial enrichments greater than 3.0 w/o ^{235}U and contain axial blankets with a nominal enrichment no greater than 2.60 w/o ^{235}U and nominal length no less than 6 inches. The minimum burnup and decay time requirements are tabulated as a function of initial enrichment in Table 5-8.

5.2.9 “2-out-of-4” Storage Configuration

The “2-OUT-OF-4” storage configuration may be employed to store fresh or depleted fuel assemblies in accordance with the storage pattern of Figure 5-6 that meet the minimum burnup requirements of Figure 5-15. The minimum burnup requirements are tabulated as a function of initial enrichment in Table 5-9.

5.3 Oversize Inspection Cell Storage

The oversize inspection cell may contain an assembly in any radial or axial position. The inspection cell shall be surrounded by empty cells in all adjacent storage locations, including diagonally adjacent locations.

5.4 Interface Requirements in the Spent Fuel Pool

Fuel storage patterns used at the interface of storage configurations shall comply with the following assembly loading requirements.

- The RCCA in the “4-out-of-4 with 1 RCCA” storage configuration shall be located along the interface.
- RackSavers in the “4-out-of-4 with 3 RackSavers and Axial Blankets” storage configuration shall be located in all storage cells along the interface.
- The RCCAs and RackSavers shall not be in face adjacent storage locations along the interface of the “4-out-of-4 with 2 RackSavers and Axial Blankets” and the “4-out-of-4 with 2 RCCAs” storage configurations.
- The RackSavers shall be oriented such that the poison is facing the adjacent storage configuration.
- In the “2-out-of-4” storage configuration, assemblies shall not be stored in face adjacent storage locations.
- In the “3-out-of-4” storage configuration, the empty cell shall be in the interface row.

Note that storage cells may be left empty.

5.5 Total Soluble Boron Requirement

The total soluble boron concentration required to maintain the k_{eff} value less than or equal to 0.95 with 95% probability at a 95% confidence level is determined to be 1607 ppm with a ^{10}B content equal to 19.44 a/o (18.0 w/o). This is the recommended minimum boron level and is sufficient to accommodate all the design requirements. Note that a lower ^{10}B atom percent will require a proportionally higher amount of soluble boron.

Table 5-1. Minimum Required Assembly-Average Burnup versus Initial ²³⁵U Enrichment and Decay Time for the “4-out-of-4” Storage Configuration

Initial Enrichment (w/o ²³⁵ U)	Assembly Average Burnup (MWd/MTU)				
	0 yr Decay	5 yr Decay	10 yr Decay	15 yr Decay	20 yr Decay
1.02	0	0	0	0	0
2.0	25,227	22,305	20,667	19,553	18,847
3.0	43,461	39,317	36,770	35,099	33,786
4.0	60,393	55,404	52,269	50,002	48,453
5.0	75,729	70,443	66,546	63,927	62,183

The required assembly burnup as a function of ²³⁵U enrichment and decay time in the “4-out-of-4” storage configuration is described by the following polynomials:

$$\text{Assembly BU (0 years)} = -277.09 e^4 + 3830.34 e^3 - 19884.13 e^2 + 62889.04 e - 47224.22$$

$$\text{Assembly BU (5 years)} = -210.79 e^4 + 2930.93 e^3 - 15247.94 e^2 + 51265.67 e - 39309.18$$

$$\text{Assembly BU (10 years)} = -212.65 e^4 + 2874.27 e^3 - 14474.87 e^2 + 47688.69 e - 36402.82$$

$$\text{Assembly BU (15 years)} = -174.57 e^4 + 2388.12 e^3 - 12213.19 e^2 + 42584.68 e - 33075.11$$

$$\text{Assembly BU (20 years)} = -199.33 e^4 + 2679.59 e^3 - 13288.61 e^2 + 43425.35 e - 33096.22$$

Table 5-2. Minimum Required Assembly-Average Burnup versus Initial ²³⁵U Enrichment and Decay Time for the “4-out-of-4 with Axial Blankets” Storage Configuration

Initial Enrichment (w/o ²³⁵ U)	Assembly Average Burnup (MWd/MTU)				
	0 yr Decay	5 yr Decay	10 yr Decay	15 yr Decay	20 yr Decay
3.0	38,481	34,756	32,340	30,701	29,492
4.0	51,086	46,707	43,890	41,901	40,426
5.0	62,662	57,806	54,659	52,289	50,730

The required assembly burnup as a function of ²³⁵U enrichment and decay time in the “4-out-of-4 with Axial Blankets” storage configuration is described by the following polynomials:

$$\text{Assembly Burnup (0 years)} = - 514.66 e^2 + 16207.69 e - 5509.79$$

$$\text{Assembly Burnup (5 years)} = - 425.83 e^2 + 14931.50 e - 6206.07$$

$$\text{Assembly Burnup (10 years)} = - 390.35 e^2 + 14282.12 e - 6993.09$$

$$\text{Assembly Burnup (15 years)} = - 406.52 e^2 + 14046.16 e - 7778.98$$

$$\text{Assembly Burnup (20 years)} = - 314.67 e^2 + 13135.96 e - 7083.44$$

Table 5-3. Minimum Required Assembly-Average Burnup versus Initial ²³⁵U Enrichment and Decay Time for the “4-out-of-4 with 1 RCCA” Storage Configuration

Initial Enrichment (w/o ²³⁵ U)	Assembly Average Burnup (MWd/MTU)	
	0 yr Decay	10 yr Decay
1.20	0	0
2.0	17,418	12,667
3.0	33,832	28,930
4.0	49,684	43,450
5.0	64,743	57,229

The required assembly burnup as a function of ²³⁵U enrichment and decay time in the “4-out-of-4 with 1 RCCA” storage configuration is described by the following polynomials:

$$\text{Assembly BU (0 years)} = -281.25 e^4 + 3898.99 e^3 - 19903.20 e^2 + 60130.38 e - 49992.91$$

$$\text{Assembly BU (10 years)} = 138.62 e^4 - 1773.60 e^3 + 7466.42 e^2 + 3618.92 e - 12465.59$$

Table 5-4. Minimum Required Assembly-Average Burnup versus Initial ²³⁵U Enrichment and Decay Time for the “4-out-of-4 with 2 RCCAs” Storage Configuration

Initial Enrichment (w/o ²³⁵ U)	Assembly Average Burnup (MWd/MTU)	
	0 yr Decay	10 yr Decay
1.53	0	0
2.0	9,395	8,377
3.0	23,349	20,623
4.0	37,416	33,377
5.0	51,378	45,907

The required assembly burnup as a function of ²³⁵U enrichment and decay time in the “4-out-of-4 with 2 RCCAs” storage configuration is described by the following polynomials:

$$\text{Assembly BU (0 years)} = -496.09 e^4 + 6908.92 e^3 - 34838.84 e^2 + 89124.58 e - 76832.71$$

$$\text{Assembly BU (10 years)} = -507.57 e^4 + 6984.01 e^3 - 34685.65 e^2 + 85969.85 e - 72570.67$$

Table 5-5. Minimum Required Assembly Burnup versus Initial ²³⁵U Enrichment for the “4-out-of-4 with 2 RackSavers and Axial Blankets” Storage Configuration

Initial Enrichment (w/o ²³⁵U)	Assembly-Average Burnup (MWd/MTU)
3.0	25,265
4.0	37,132
5.0	48,088

The required assembly burnup as a function of ²³⁵U enrichment in the “4-out-of-4 with 2 RackSavers and Axial Blankets” storage configuration is described by the following polynomial:

$$\text{Assembly Burnup} = -248.31 e^4 + 3604.73 e^3 - 19626.18 e^2 + 59329.46 e - 53302.18$$

Table 5-6. Minimum Required Assembly Burnup versus Initial ²³⁵U Enrichment for the “4-out-of-4 with 3 RackSavers and Axial Blankets” Storage Configuration

Initial Enrichment (w/o ²³⁵U)	Assembly-Average Burnup (MWd/MTU)
3.0	18,763
4.0	30,064
5.0	40,568

The required assembly burnup as a function of ²³⁵U enrichment in the “4-out-of-4 with 3 RackSavers and Axial Blankets” storage configuration is described by the following polynomial:

$$\text{Assembly Burnup} = -284.56 e^4 + 4094.97 e^3 - 21936.28 e^2 + 63139.78 e - 60745.08$$

Table 5-7. Minimum Required Assembly-Average Burnup versus Initial ²³⁵U Enrichment and Decay Time for the “3-out-of-4” Storage Configuration

Initial Enrichment (w/o ²³⁵ U)	Assembly Average Burnup (MWd/MTU)				
	0 yr Decay	5 yr Decay	10 yr Decay	15 yr Decay	20 yr Decay
1.47	0	0	0	0	0
2.0	8,769	8,214	7,890	7,675	7,394
3.0	21,547	20,072	19,172	18,511	18,079
4.0	34,431	32,161	30,715	29,833	29,057
5.0	46,666	43,976	42,226	41,015	40,059

The required assembly burnup as a function of ²³⁵U enrichment and decay time in the “3-out-of-4” storage configuration is described by the following polynomials:

$$\text{Assembly BU (0 years)} = -317.38 e^4 + 4317.53 e^3 - 21348.63 e^2 + 58117.17 e - 51532.74$$

$$\text{Assembly BU (5 years)} = -303.14 e^4 + 4159.82 e^3 - 20650.21 e^2 + 55776.73 e - 49167.02$$

$$\text{Assembly BU (10 years)} = -292.15 e^4 + 4041.40 e^3 - 20173.97 e^2 + 54355.11 e - 47781.47$$

$$\text{Assembly BU (15 years)} = -323.74 e^4 + 4427.70 e^3 - 21800.05 e^2 + 56752.59 e - 48871.58$$

$$\text{Assembly BU (20 years)} = -268.51 e^4 + 3712.86 e^3 - 18501.43 e^2 + 50100.97 e - 44208.88$$

Table 5-8. Minimum Required Assembly-Average Burnup versus Initial ²³⁵U Enrichment and Decay Time for the “3-out-of-4 with Axial Blankets” Storage Configuration

Initial Enrichment (w/o ²³⁵ U)	Assembly Average Burnup (MWd/MTU)				
	0 yr Decay	5 yr Decay	10 yr Decay	15 yr Decay	20 yr Decay
3.0	21,188	19,670	18,713	18,050	17,542
4.0	32,077	29,976	28,453	27,453	26,742
5.0	42,327	39,562	37,682	36,376	35,490

The required assembly burnup as a function of ²³⁵U enrichment and decay time in the “3-out-of-4 with Axial Blankets” storage configuration is described by the following polynomials:

$$\text{Assembly Burnup (0 years)} = -319.45 e^2 + 13125.07 e - 15311.99$$

$$\text{Assembly Burnup (5 years)} = -360.22 e^2 + 12827.56 e - 15570.74$$

$$\text{Assembly Burnup (10 years)} = -255.35 e^2 + 11527.23 e - 13570.44$$

$$\text{Assembly Burnup (15 years)} = -240.27 e^2 + 11085.22 e - 13043.21$$

$$\text{Assembly Burnup (20 years)} = -225.65 e^2 + 10779.10 e - 12764.25$$

Table 5-9. Minimum Required Assembly Burnup versus Initial ²³⁵U Enrichment for the “2-out-of-4” Storage Configuration

Initial Enrichment (w/o ²³⁵U)	Assembly-Average Burnup (MWd/MTU)
3.67	0
4.0	1,627
5.0	6,604

The required assembly burnup as a function of ²³⁵U enrichment in the “2-out-of-4” storage configuration is described by the following polynomial:

$$\text{Assembly Burnup} = 34.06 e^2 + 4669.99 e - 17597.61$$

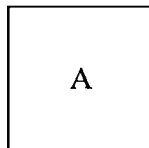
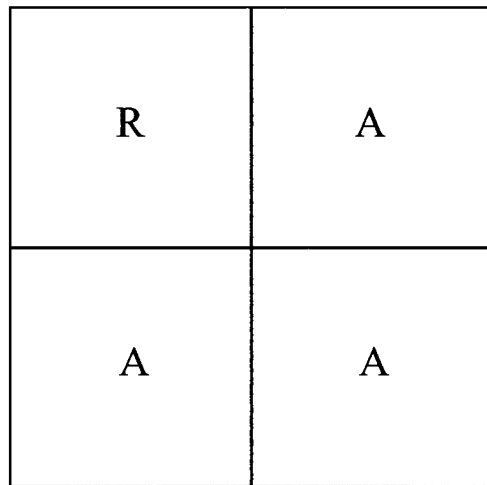

Storage cell with assembly that meets the minimum burnup requirement of Figure 5-9.

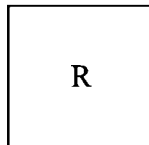

Storage cell with assembly and RCCA that meets the minimum burnup requirement of Figure 5-9.

Figure 5-1. “4-out-of-4 with 1 RCCA” Storage Configuration Illustration

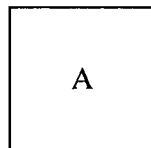
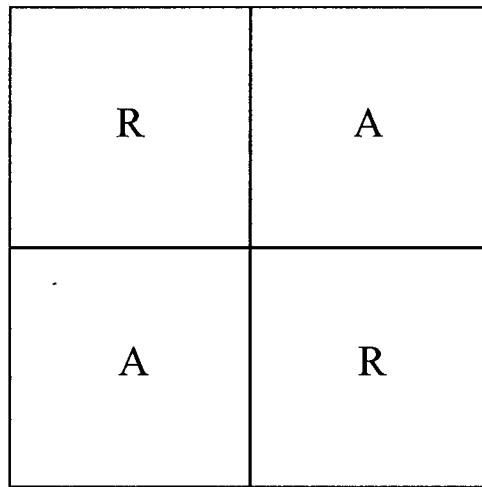

Storage cell with assembly that meets the minimum burnup requirement of Figure 5-10.

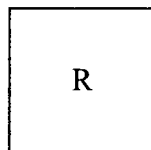

Storage cell with assembly and RCCA that meets the minimum burnup requirement of Figure 5-10.

Figure 5-2. "4-out-of-4 with 2 RCCA" Storage Configuration Illustration

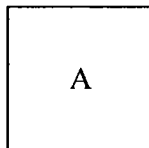
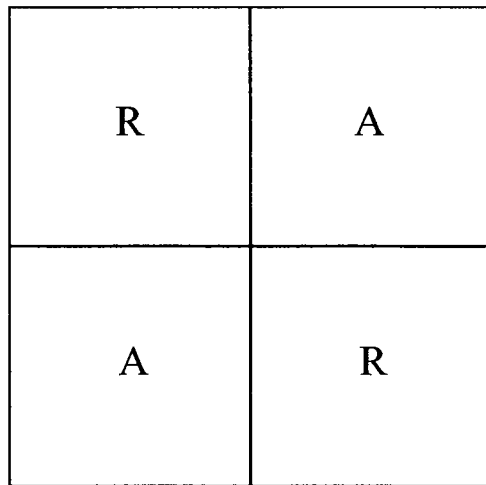

Storage cell with assembly that meets the minimum burnup requirement of Figure 5-11.

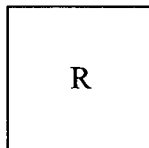

Storage cell with assembly and Racksaver that meets the minimum burnup requirement of Figure 5-11.

Figure 5-3. “4-out-of-4 with 2 RackSavers and Axial Blankets” Storage Configuration Illustration

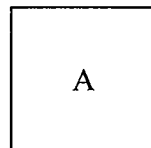
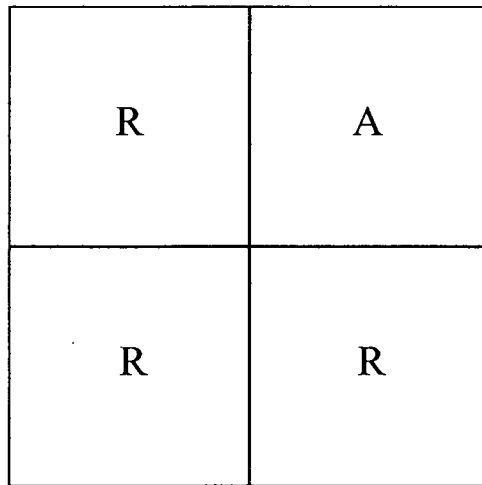

Storage cell with assembly that meets the minimum burnup requirement of Figure 5-12.

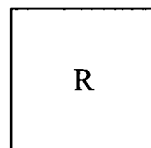

Storage cell with assembly and Racksaver that meets the minimum burnup requirement of Figure 5-12.

Figure 5-4. “4-out-of-4 with 3 RackSavers and Axial Blankets” Storage Configuration Illustration

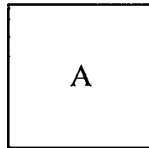
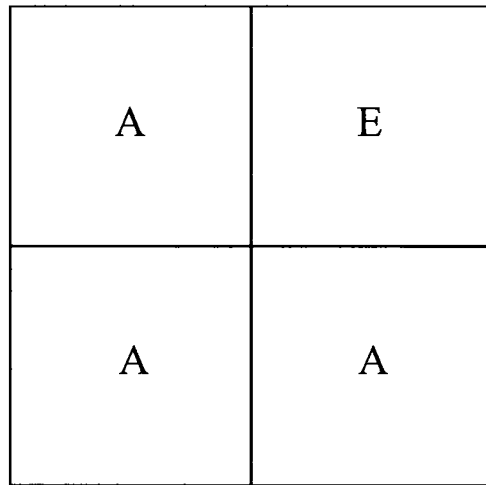

Storage cell with assembly that meets the minimum burnup requirement of Figure 5-13 or Figure 5-14 if all assemblies have axial blankets.

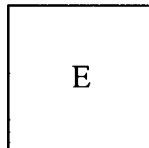

Empty storage cell.

Figure 5-5. "3-out-of-4" Storage Configuration Illustration

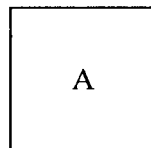
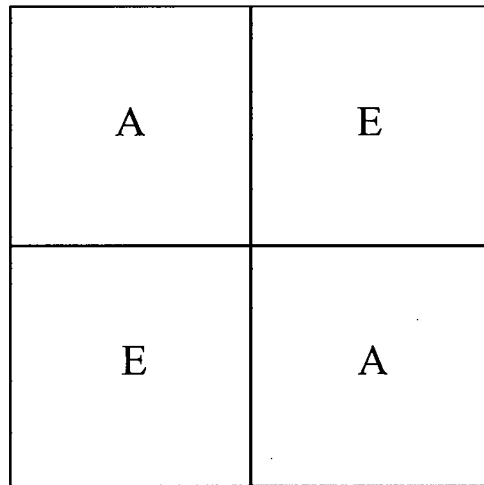

Storage cell with assembly that meets the minimum burnup requirement of Figure 5-15.

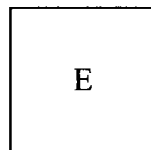

Empty storage cell.

Figure 5-6. “2-out-of-4” Storage Configuration Illustration

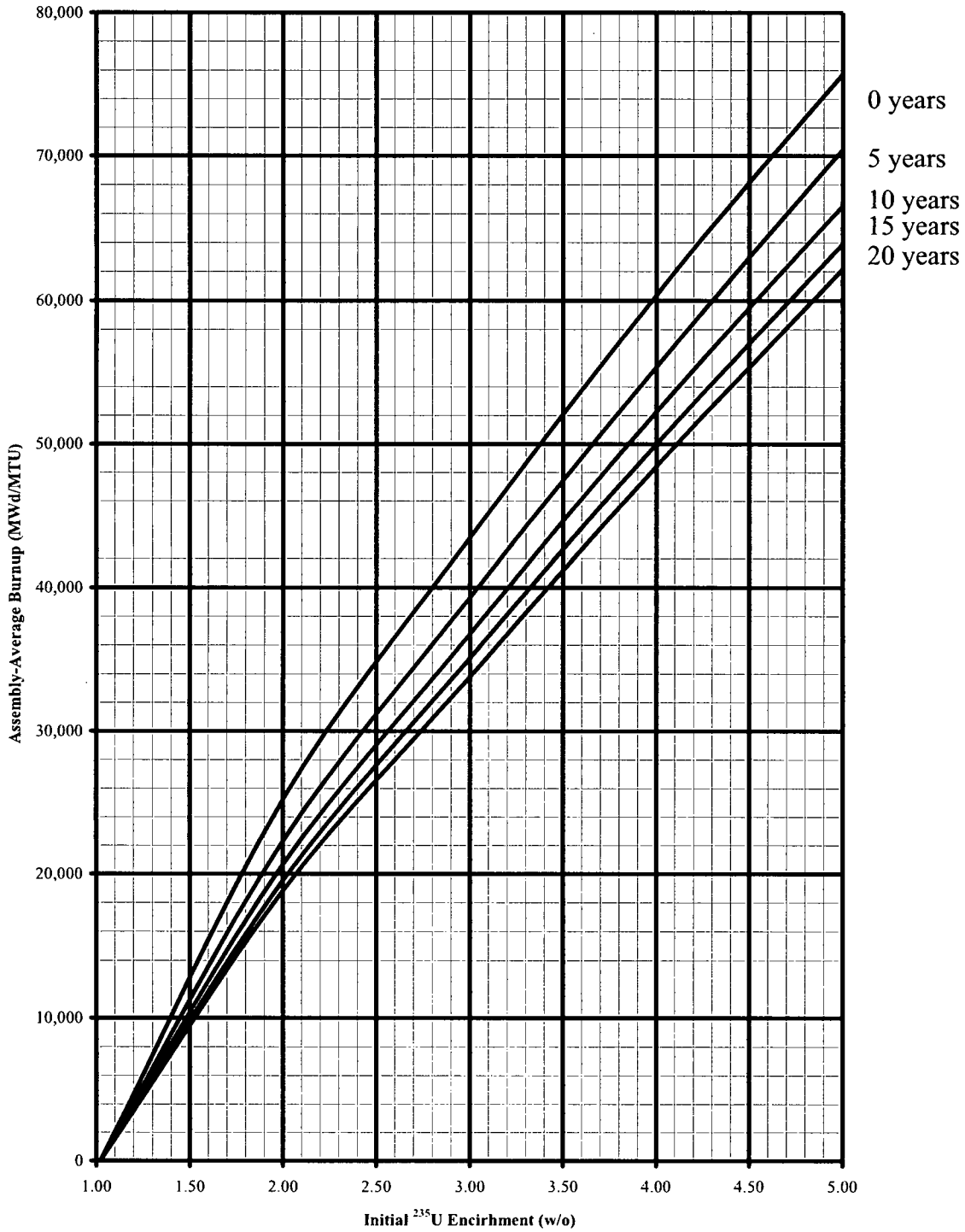

Figure 5-7. Minimum Required Fuel Assembly Burnup versus Initial ²³⁵U Enrichment for the "4-out-of-4" Storage Configuration

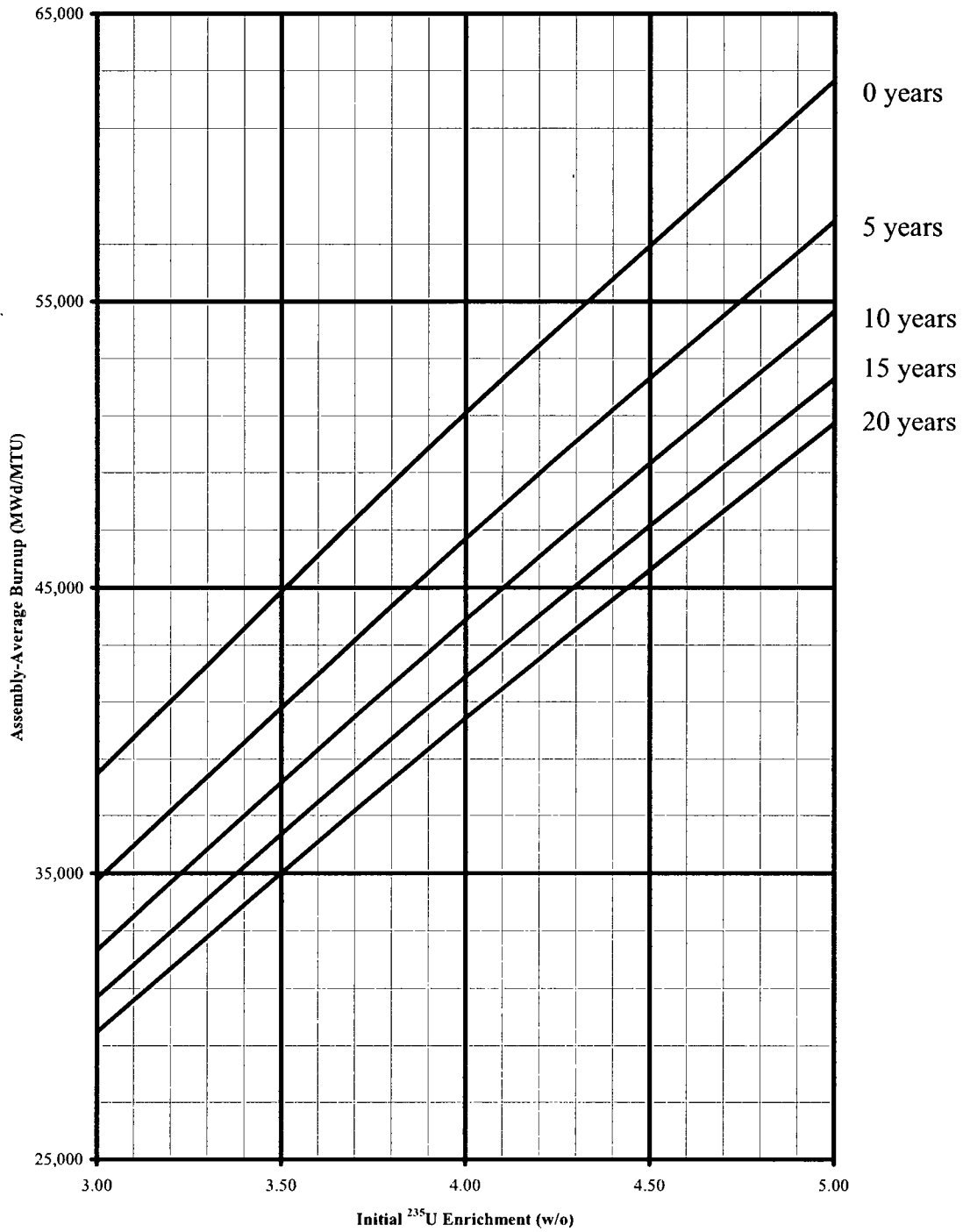

Figure 5-8. Minimum Required Fuel Assembly Burnup versus Initial ²³⁵U Enrichment for the "4-out-of-4 with Axial Blankets" Storage Configuration

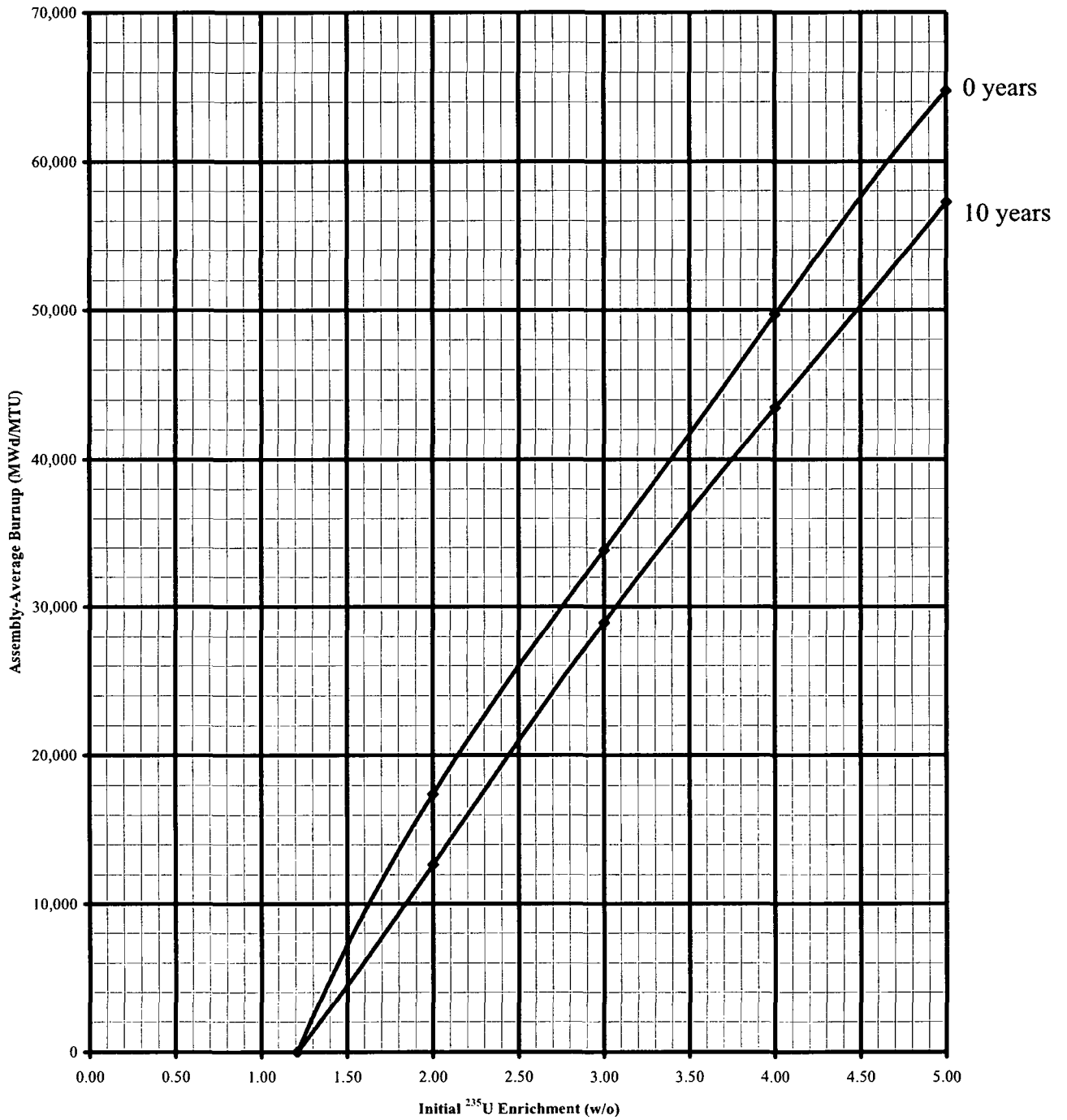

Figure 5-9. Minimum Required Fuel Assembly Burnup versus Initial ²³⁵U Enrichment for the "4-out-of-4 with 1 RCCA" Storage Configuration

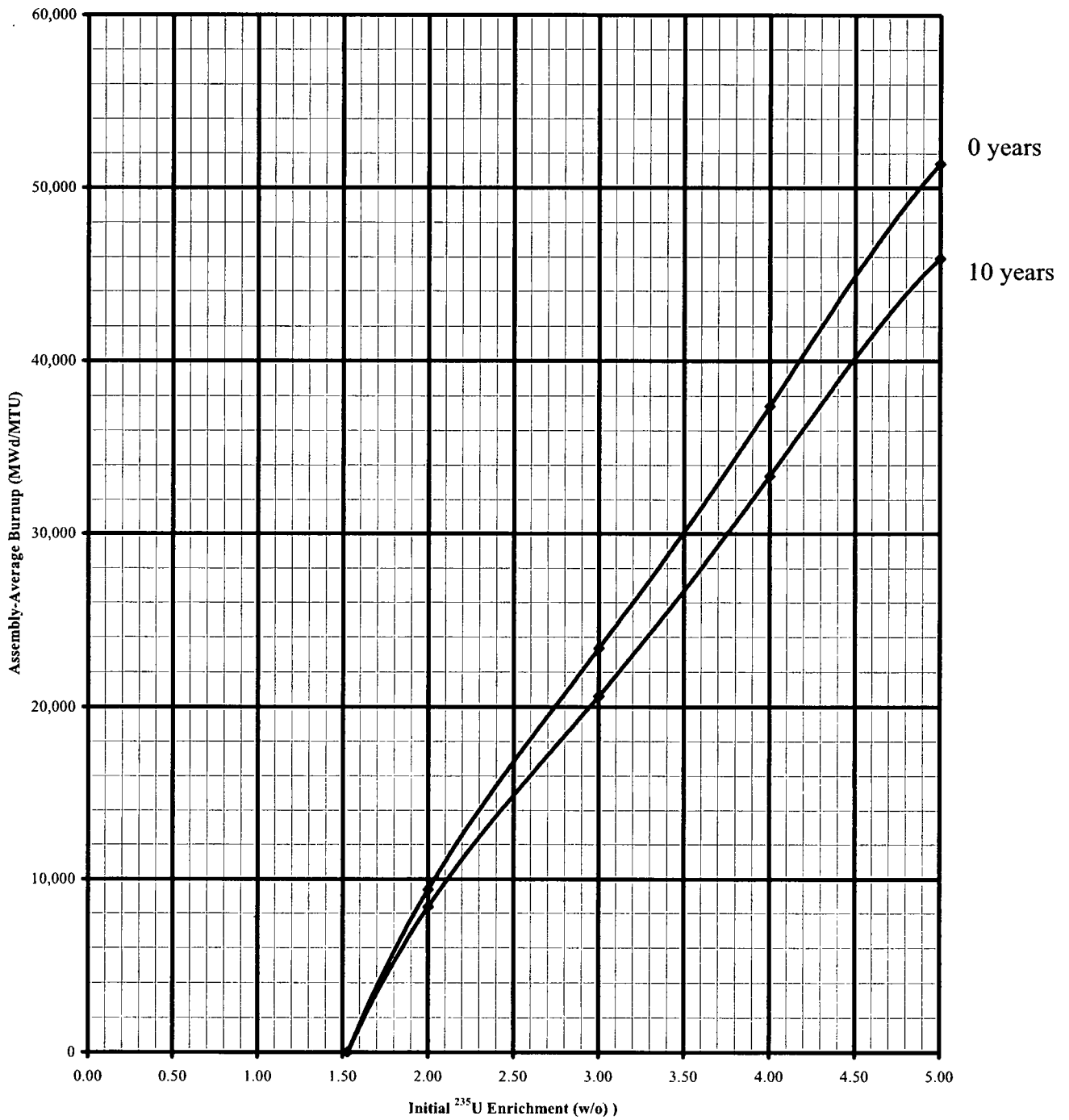

Figure 5-10. Minimum Required Fuel Assembly Burnup versus Initial ²³⁵U Enrichment for the "4-out-of-4 with 2 RCCAs" Storage Configuration

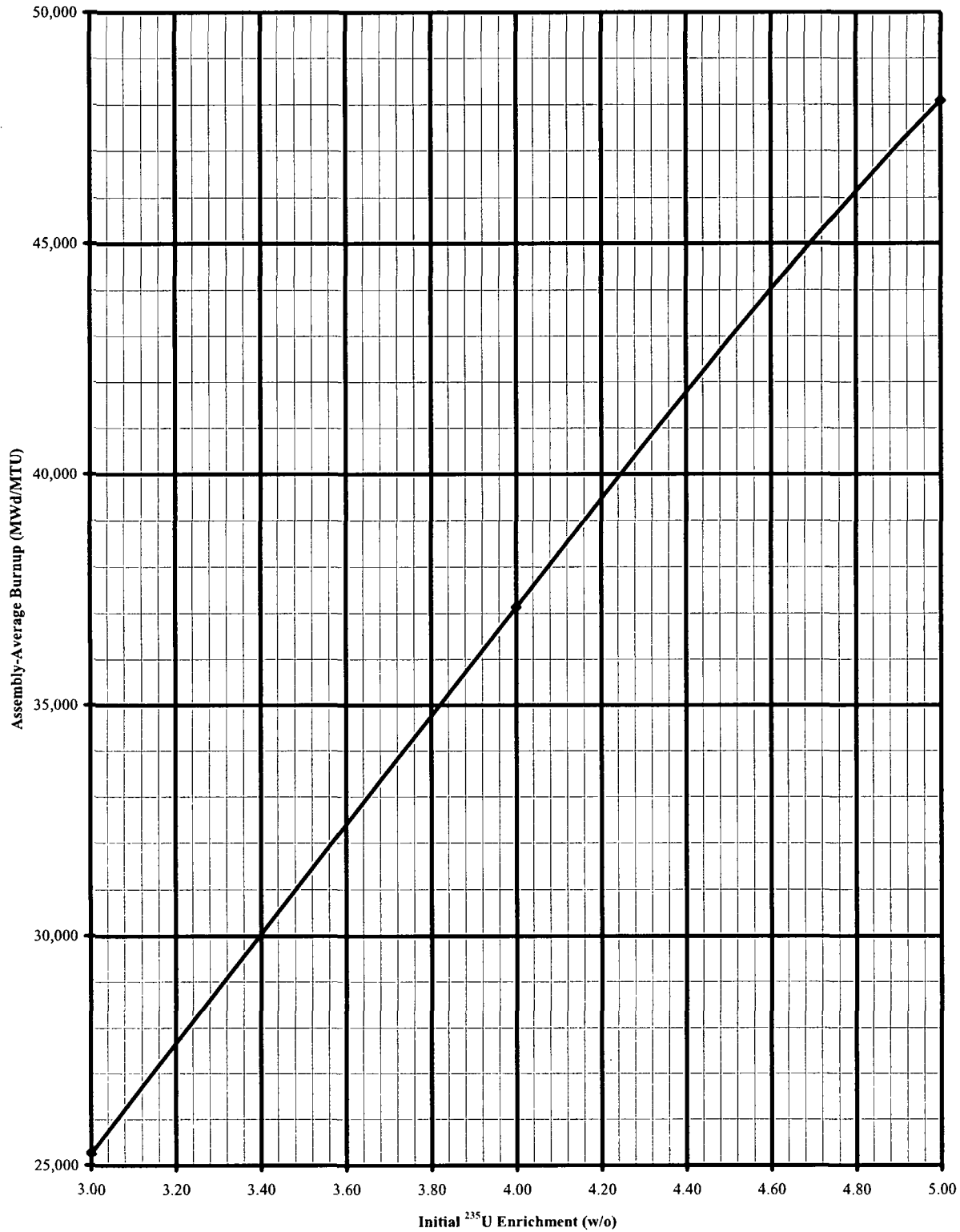

Figure 5-11. Minimum Required Fuel Assembly Burnup versus Initial ²³⁵U Enrichment for the "4-out-of-4 with 2 RackSavers and Axial Blankets" Storage Configuration

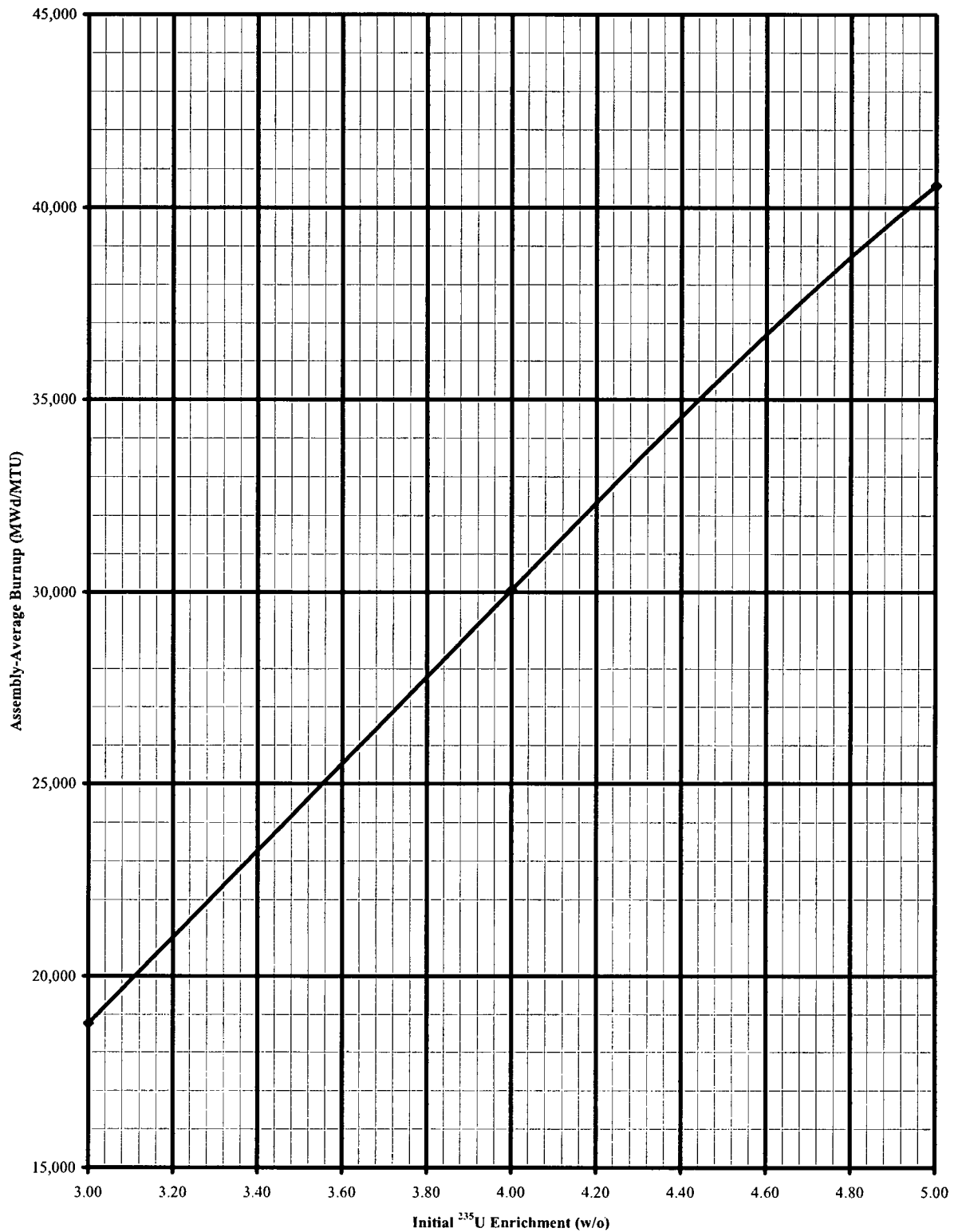

Figure 5-12. Minimum Required Fuel Assembly Burnup versus Initial ²³⁵U Enrichment for the "4-out-of-4 with 3 RackSavers and Axial Blankets" Storage Configuration

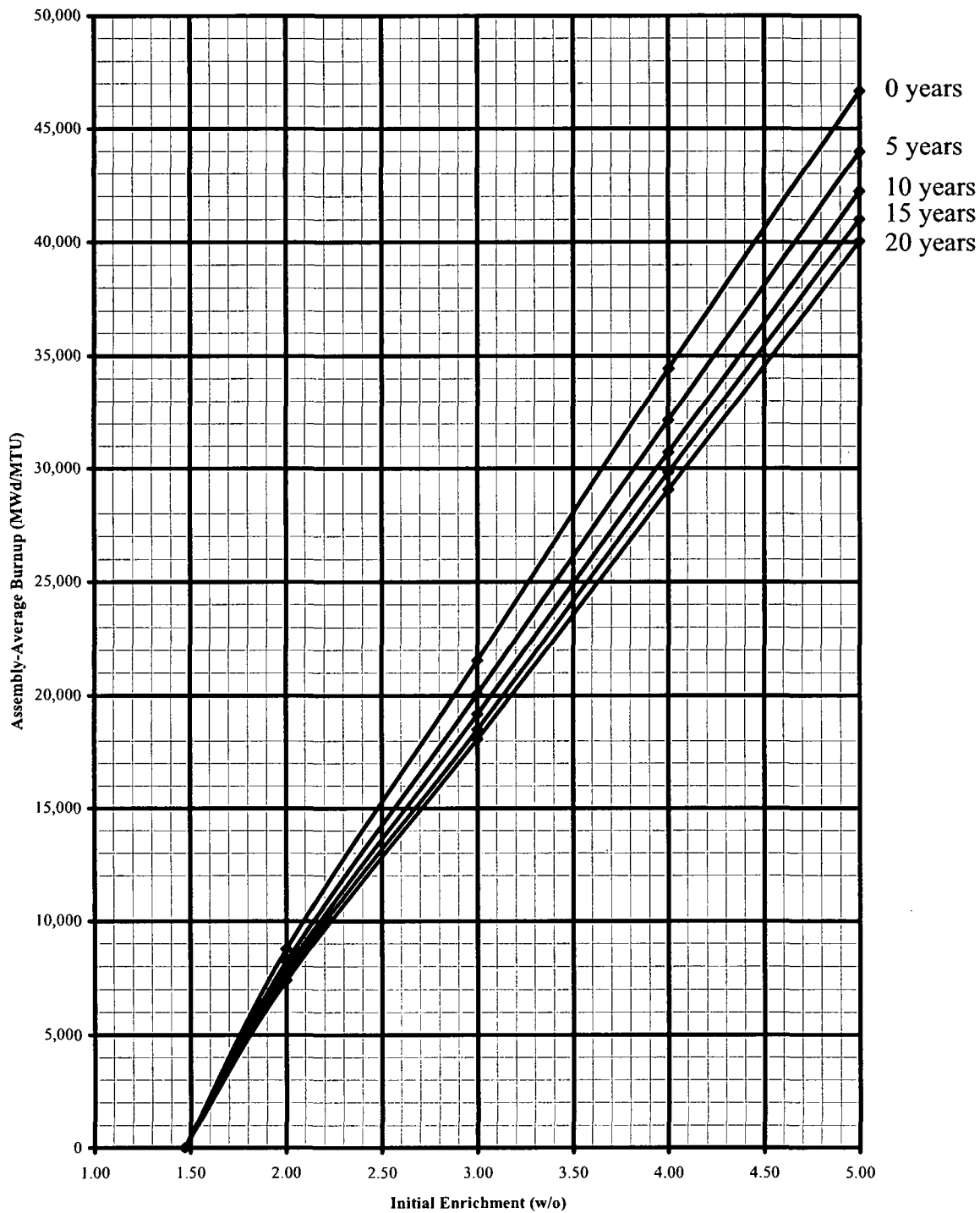

Figure 5-13. Minimum Required Fuel Assembly Burnup versus Initial ²³⁵U Enrichment for the "3-out-of-4" Storage Configuration

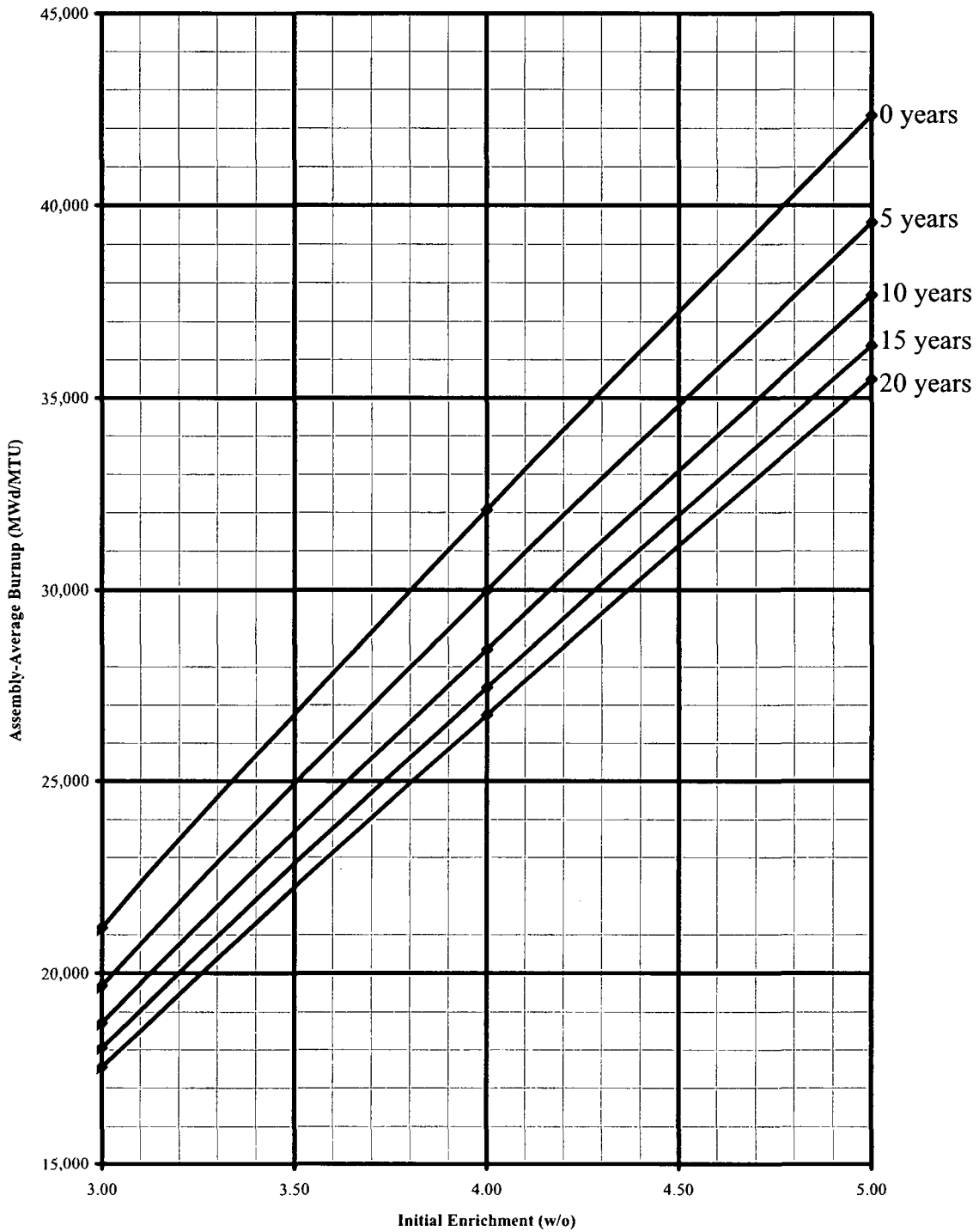

Figure 5-14. Minimum Required Fuel Assembly Burnup versus Initial ²³⁵U Enrichment for the "3-out-of-4 with Axial Blankets" Storage Configuration

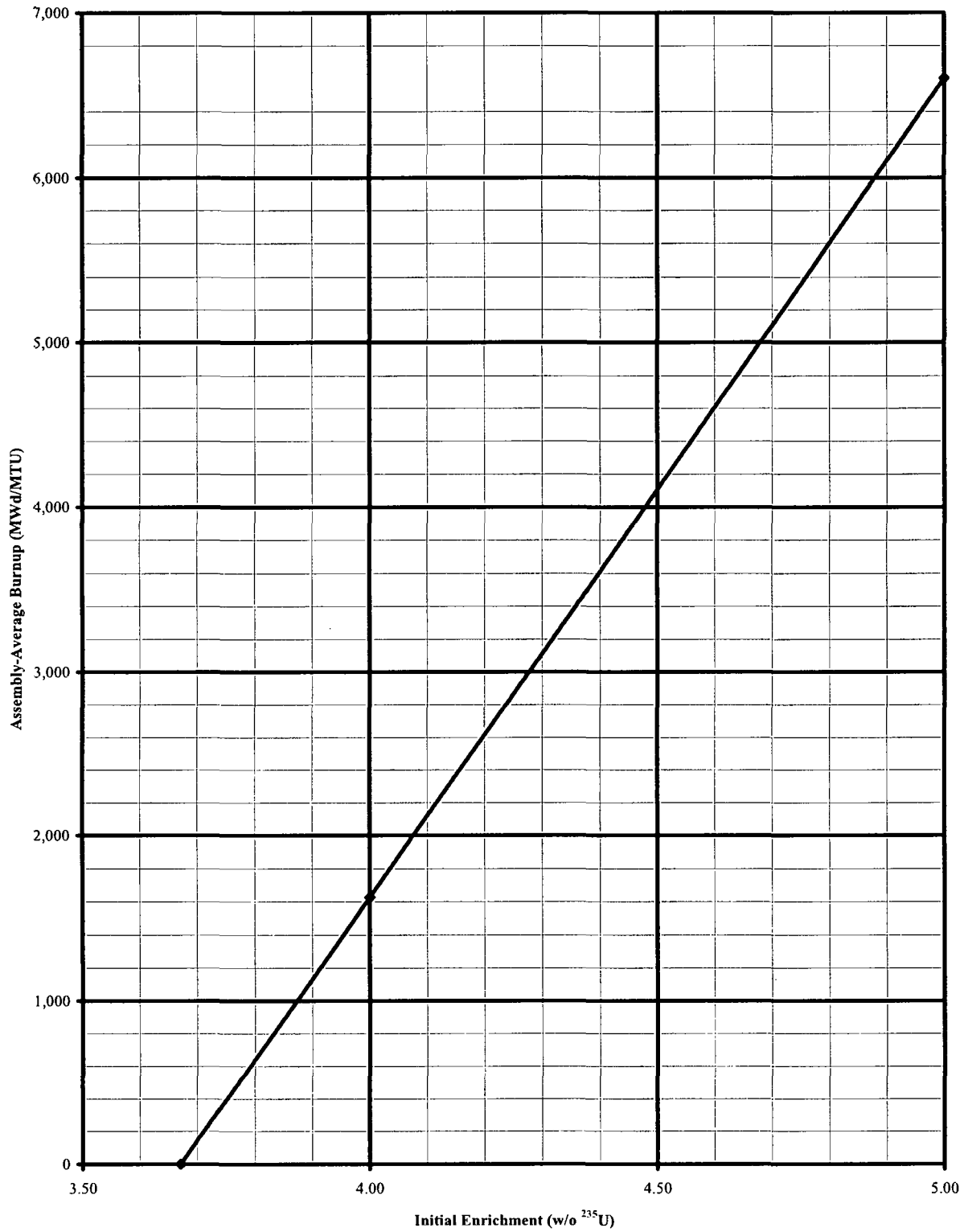

Figure 5-15. Minimum Required Fuel Assembly Burnup versus Initial ²³⁵U Enrichment for the "2-out-of-4" Storage Configuration

“This page intentionally left blank.”

6.0 References

1. Letter, G. S. Vissing (NRC) to R. C. Mecredy (RGE), "R. E. Ginna Nuclear Power Plant – Amendment Re-Revision to the Storage Configuration Requirements within the Existing Storage Racking and Taking Credit for a Limited Amount of Soluble Boron," December 7, 2000.
2. Code of Federal Regulations, Title 10, Part 50, Appendix A, Criterion 62, "Prevention of Criticality in Fuel Storage and Handling".
3. L. Kopp (NRC), "Guidance on the Regulatory Requirements for Criticality Analysis of Fuel Storage at Light-Water Reactor Power Plants", August 19, 1998.
4. "Criticality Safety Criteria for the Handling, Storage, and Transportation of LWR Fuel Outside Reactors", ANSI/ANS-8.17-2004, November 3, 2004.
5. "SCALE: A Modular Code System for Performing Standardized Computer Analyses for Licensing Evaluation", NUREG/CR-0200; distributed by the Radiation Shielding Information Center, Oak Ridge National Laboratory, Oak Ridge, Tennessee, September 1998.
6. M.N. Baldwin, et al., "Critical Experiments Supporting Close Proximity Water Storage of Power Reactor Fuel; Summary Report", BAW-1484-7, July 1979.
7. S.R. Bierman and E.D. Clayton, "Critical Experiments with Subcritical Clusters of 2.35 Wt% ²³⁵U Enriched UO₂ Rods in Water at a Water-to-Fuel Volume Ratio of 1.6", NUREG/CR-1547, PNL-3314, July 1980.
8. S.R. Bierman and E.D. Clayton, "Criticality Experiments with Subcritical Clusters of 2.35 and 4.31 Wt% U-Enriched UO₂ Rods in Water with Steel Reflecting Walls", Nuclear Technology, Vol. 54, pg. 131, August 1981.
9. International Handbook of Evaluated Criticality Safety Benchmark Experiments, Nuclear Energy Agency and Organization for Economic Cooperation and Development.
10. W. Marshall, et al., "Criticality Safety Criteria", TANS Vol. 35, pg. 278, 1980.
11. D. Lurie and R. Moore, "Applying Statistics", NUREG-1475, USNRC, February 1994.
12. J. C. Wagner and M. D. DeHart, "Review of Axial Burnup Distribution Considerations for Burnup Credit Calculations," ORNL/TM-1999/246, March 2000.
13. J. C. Wagner and M. D. DeHart, "Recommendations for Addressing Axial Burnup in PWR Burnup Credit Analyses," ORNL/TM-2001/273, March 2003.

14. C. Lemons, "Transmittal of Design Information – CPSES Units 1 and 2 SPF Criticality Analysis Design Inputs," CPSES-2007000138 (transmittal from TXU to Westinghouse), January 2007.
15. T. C. Nguyen, et al, "Qualification of the PHOENIX-P/ANC Nuclear Design System for Pressurized Water Reactor Cores," WCAP-11596-P-A, Revision 0, June 1988.