

# Final Precursor Analysis

Accident Sequence Precursor Program -- Office of Nuclear Regulatory Research

<b>River Bend Station</b>	<b>Automatic Reactor Trip Due to Loss of Non-Vital 120V Instrument Bus</b>	
<b>Event Date 12/10/2004</b>	<b>LER: 458/04-005-01</b>	<b>CCDP<sup>1</sup> =2.7 x 10<sup>-5</sup></b>

May 16, 2006

## Event Summary

On December 10, 2004, at 1:17p.m. CST, with the unit operating at 100% power, a capacitor shorted on the static switch control board of the non-safety-related ELGAR (Model UPS-503-1-102) static inverter BYS-INV01B (See Figure 1). As a result, power was lost to 120V Instrument Bus VBN-PNL01B1 (References 1, 2). This resulted in: a loss of control power to the feedwater regulating valves, and a downshift in the speed setting for the B Reactor Recirculation pump, as well as a loss of indication to several instruments powered by the Instrument Bus. The loss of control power to the feedwater regulating valves resulted in them "locking-up" in place. This resulted in an overfeed condition and the additional cold water caused in increase in thermal neutron power. The lowering recirculation system flow caused the Average Power Rate Meter (APRM) power-to-flow setpoint to lower. The reactor then automatically tripped on high APRM power level.

With the main feedwater regulating valves locked-up in their full power position, excess feedwater was delivered to the reactor pressure vessel (RPV) causing a high level in the RPV. This resulted in an automatic high RPV water level trip of the running feedwater pumps (Reference 2). In response to this, operators initiated Reactor Core Isolation Cooling (RCIC) to maintain post-trip reactor water level, which should have lowered rapidly *had the feedwater regulating valves not been locked up in the 100% flow position before the feedwater pumps tripped*. Immediately after RCIC was initiated, it shut down approximately 11 seconds later and the RCIC turbine steam supply valve closed as designed in response to the high RPV level trip signal. The operators then prepared to re-initiate RCIC once the high level trip cleared as the reactor continued to generate steam through the main turbine bypass valves to the main condenser. While the RCIC was idle, an alarm actuated indicating presence of water in the RCIC turbine exhaust line drain trap.

Wide range reactor water level recorders B21-R623A and B21-R623B digital indications continued to rise above the top of scale +60 inches. The indication stopped rising at +150 inches. The operators questioned further use of RCIC for water level control because they were concerned that the main steam lines might be filled with water. The main steam lines leave the RPV at approximately +95 inches. The operators discussed an operating experience event during which operators at another plant started RCIC with water in the steam line. In that

---

<sup>1</sup> For the initiating event assessment, the parameter of interest is the measure of the CCDP. This is the value obtained when calculating the probability of core damage for an initiating event with subsequent failure of one or more components following the initiating event. The value reported here is the mean value.

instance, the turbine tripped on overspeed and required local action to reset the turbine trip. Also, complicating the operators' decision making process was the loss of the only valid indication of reactor water level: the upset range indicator, which was directly lost due to the loss of 120V Instrument Bus VBN-PNL01B1 and the unexpected RCIC alarms. *This resulted in a situation in which there were totally contradictory level indications presented to the operators from the main control board.*

As a result, when the RPV level returned on-scale on the wide range and narrow range reactor water level instruments, the operators used the High Pressure Core Spray (HPCS) for reactor water level control. This complicated the operators' response to the event, since HPCS draws water from condensate storage and adds water to the suppression pool when it is not used to add water to the RPV. As a result, the operators had to start the RHR system in the suppression pool cooling to facilitate rejecting water from the suppression pool to radwaste to maintain suppression pool level below high level action points.

The 120V Instrument Bus VBN-PNL01B1 was shifted to an alternate power source by placing the UPS in the manual bypass mode (See Figure 1). The feedwater regulating system was restored to service at approximately 4:57 p.m. CST on the same day, and the HPCS was secured and returned to its normal standby configuration.

## Analysis Results

- **Conditional Core Damage Probability (CCDP)**

This event was modeled as a general plant transient with additional failures caused by the loss of 120V Non-Vital Instrument Power. The additional failures included: loss of ability to automatically regulate feedwater flow (which caused a high RPV water level condition and led to tripping of all running feedwater pumps and the RCIC) and the loss of several RPV level indications on the main control board which complicated the operators' response to the event. The CCDP for this event was calculated as  $2.7 \times 10^{-5}$  (point estimate). An uncertainty analysis was performed to assess the effects of parameter uncertainties. The results of the uncertainty analysis are summarized below.

	CCDP		
	5%	Mean	95%
<b>River Bend Station</b>	<b><math>3.5 \times 10^{-6}</math></b>	<b><math>2.7 \times 10^{-5}</math></b>	<b><math>9.1 \times 10^{-5}</math></b>

- **Dominant Sequences**

Appendix A provides the event tree models used in this analysis. The actual event sequence of the December 10, 2004 event is similar to Sequence 10, shown in Figure A-1 of Appendix A. If additional system or component failures had occurred, a core damage sequence could occur.

There is one dominant accident sequence (See Table 1) which accounts for 99% of the total CCDP. All other accident sequences account for less than 1% of the total CCDP.

The dominant sequence involves a transient shutdown followed by the failure of all high pressure makeup systems (main feedwater, HPCS, RCIC), and then a failure to manually depressurize the RPV and go on to low pressure makeup systems.

- **Results Tables**

- The conditional probabilities for the dominant sequences are shown in Table 1.
- The event tree sequence logic for the dominant sequences are presented in Table 2a.
- Table 2b defines the nomenclature used in Table 2a.
- The most important cut sets for the dominant sequences are listed in Table 3a and 3b.
- Definitions and probabilities for modified or dominant basic events are provided in Table 4.

## Modeling Assumptions

- **Analysis Type**

The event was analyzed as an event analysis using the River Bend SPAR Model Revision 3.12 (Reference 3). Revision 3.12 is an updated SPAR model prepared by INEL in response to a request to separate the feedwater and main condenser functions in the event tree model.

- **Unique Design Features**

River Bend is a General Electric BWR-6, with a Mark III containment. It differs in design from Grand Gulf in the following areas: (a) the main feedwater pumps are electric motor driven pumps which can provide makeup to the RPV without a supply of steam, and (b) there is no capability for containment venting as a means of decay heat removal.

- **Modeling Assumptions Summary**

**Key modeling assumptions.** The key modeling assumptions are listed below and discussed in detail in the following sections. These assumptions are important contributors to the overall risk.

- **Loss of 120V Instrument Bus VBN-PNL01B1 resulted in an event which can be simulated as a general transient event, requiring reactor trip, continued RPV makeup to match boil-off, and pressure control/decay heat removal.** In order to properly simulate the event sequence, basic event **IE-TRANS** is set TRUE, and all other initiating events are set FALSE.
- **Loss of 120V Instrument Bus VBN-PNL01B1 “locked-up” the feedwater regulating valves in the 100% power position resulting in a high RPV water level trip of all feedwater pumps immediately following the reactor trip.**

This was simulated by adding basic event **FWLCS-OVERFILL** (set to TRUE) to the main feedwater and RCIC fault tree models as described in Figure B-1 of Appendix B.

- **In the event that all other makeup sources were unavailable, emergency RPV makeup could be provided by restarting one of the electric motor driven feedwater pumps and cycling them on/off as needed to maintain water level.** This is modeled by incorporation of a base event for non-recovery of the feedwater system: **MFW-XHE-RESTART** as shown in Figure B-1 of Appendix B.
- **The RCIC system, initially started by the operators to control post-trip RPV water level, automatically tripped after 11 seconds due to high RPV water level and operators did not restart it out of concerns of water in the steam lines.** This was simulated by adding basic event **FWLCS-OVERFILL** (set to TRUE) to the RCIC fault tree model as described in Figure B-2 of Appendix B.
- **Operators were concerned about the possibility of water in the RCIC steam line and were focused on avoiding damage to the RCIC steam turbine due to water induction. Because of this: after the RCIC tripped there was no intent to attempt restarting the RCIC.** Operators were initially confused in their response to the event due to the trip of the feedwater pumps and RCIC pump on high level, the offscale high RPV water on the narrow and wide range level indicators and the offscale low RPV water level on the upset range level indicators. The additional alarm registered for water in the RCIC turbine exhaust moisture trap would only serve to increase concerns about water induction. Because of this, *recovery of RCIC is not considered in the analysis.*
- **The High Pressure Core Spray (HPCS) was manually started to maintain post-trip RPV water level.** In the event operators failed to start HPCS as RPV water levels trended lower, the *HPCS would automatically start on low RPV level* based on one out of two taken twice coincidence logic (Section 6.3.2.2.1, Reference 4). The HPCS auto-start logic is not modeled in the current SPAR model but its operation is critical in a situation where operators are confused about actual RPV water levels. Because specific details on the design of the logic are not presented in the updated FSAR (Reference 4) an assumption is made that *the logic has a failure probability of no worse than 1E-3.* This is modeled by incorporation of basic event **HPCS-LOGIC-FAILURE** into the HPCS fault tree as is shown in Figure B-3 of Appendix B. Sensitivity studies were performed on the effects of alternate basic event probabilities and the 1E-3 failure probability is judged to be reasonable for periodically tested safety-grade instrumentation.
- **Throughout the event, RPV pressure control/decay heat removal was provided by steam bypass to the main condenser.** (Reference 1,2) Because of this, there were no actual challenges to the safety/relief valves (SRVs). Had

RPV water level trends resulted in MSIV operation, the SRVs would have cycled and discharged steam to the suppression pool. The operators when they started HPCS additionally started suppression pool cooling (RHR) as a precaution - although it was not necessary.

- **Fault Tree Modifications**

The following basic events were added to the SPAR model:

- Basic Event **FWLCS-OVERFILL** was added to both the main feedwater fault tree (Figure B-1 of Appendix B) and RCIC fault tree (Figure B-2 of Appendix B) to simulate the effects of the locked-up feedwater regulating valves which caused the tripping of both the main feedwater pumps and the RCIC on high RPV level.
- Basic Event **MFW-XHE-RESTART** was added to the main feedwater fault tree (Figure B-1 of Appendix B) to simulate the possibility of operators manually restarting a feedwater pump to provide emergency RPV makeup. *This basic event is subsequently replaced via Sequence Cutset Recovery Rules described in Appendix C.*
- The failure of RPV water level functional recovery is modeled as a single basic event: **RPV-XHE-LEVEL**. RPV water level recovery can be accomplished by either restarting a motor driven feedwater pump, starting HPCS, or by manually depressurizing the RPV and injecting water from either: the condensate pumps, the low pressure core spray pumps (LPCS), or the low pressure coolant injection (LPCI or RHR) pumps. The probability of operators failing RPV functional water level recovery is treated by sequence cutset recovery rules documented in Appendix C. The probability of basic event **RPV-XHE-LEVEL** is developed in the Human Reliability in Appendix D.
- Basic Event **HPCS-LOGIC-FAILURE** was added to the HPCS fault tree (Figure B-3 of Appendix B) to simulate the automatic start capability of the HPCS given sensed one of two - taken twice - low RPV level signals. The base case SPAR Model (Reference 3), as a simplification does not model the automatic start capability of HPCS. In many cases this capability is not significant to understanding the risk of operating events. For situations where both feedwater and RCIC have tripped due to high level trips and the level instrumentation is providing contradictory indications to operators, the automatics start capability of HPCS must be incorporated into the assessment in order to properly characterize the risk.

- **Basic Event Probability Changes**

Table 4 provides all the basic events that were modified to reflect the best estimate of the conditions during the event. **IE-TRANS** is set TRUE, and all other initiating events

are set FALSE. No other changes were made to Base Case SPAR basic event probabilities.

- **SPAR Model Corrections**

The base case River Bend SPAR model Revision 3.11 was based upon a simplification that feedwater and main condenser are treated as one event tree decision node and that the failure of either system fails both. This simplification does not properly represent actual BWR emergency operating procedures in which feedwater can be used for makeup despite loss of the main condenser, or the use of RCIC or HPCS as a makeup source when the feedwater system has failed and the main condenser is being used for decay heat removal/RPV pressure control. INEL personnel were contacted to make a modification to the general plant transient event tree. This resulted in River Bend SPAR Model 3.12 (Reference 3).

- **Sensitivity Analyses**

Sensitivity analyses were performed to determine the effects of data and modeling uncertainties on the CCDP point estimate result which is treated as the base case. To assess data uncertainties, an Importance Analysis using Fussel-Vesely and Risk Increase Ratio importance measures was conducted to identify the most sensitive parameters. The Fussel-Vesely importance measure ranks basic events according to the weight of the cutsets in which they appear. The Risk Increase Ratio Importance identifies those parameters which if they vary from the current value to 1.0 (failed) cause the largest increase in CCDP. This analysis identified that the CCDP is particularly sensitive to the following basic events:

<b>HPCS-LOGIC-FAILURE</b>	HPCS actuation logic failure	1.0E-003
<b>RPV-XHE-LEVEL</b>	Failure of Operators to restore RPV level	2.5E-003
<b>HCS-MDP-TM-TRAIN</b>	HPCS Pump test/maintenance unavailability	7.0E-003
<b>HCS-MDP-FS-HPCS</b>	HPCS Pump fails to start	1.5E-003

The HPCS logic failure probability (1.0E-3) is recognized as a *modeling assumption* used in lieu of creating a detailed fault tree model. The documentation on the logic design for River Bend Station is not available to support such model development. To evaluate the effects of this modeling assumption, a parametric study bound the entire range of possible failure probabilities (e.g., 0.0 - 1.0) was performed. The results of this sensitivity study are shown graphically in Figure 2. Figure 2 shows that as the failure probability of the logic becomes less than 1E-3, it has no effect on the results. This is because for values smaller than this, other faults dominate the overall failure probability of HPCS (e.g., failure to start, test/maintenance unavailability, and failure to run, etc.). The likelihood that the actual HPCS logic failure probability is larger than the assumed value (e.g., 1.0E-3) is considered remote because of the following considerations: the logic is safety grade, “one out of two taken twice” redundant, and is subject to periodic surveillance and technical specification operability requirements.

The other base events failure probabilities are developed in the SPAR model documentation (Reference 3) or in the Human Reliability Assessment in Appendix D based on the SPAR-H

Process. The following table provides the results of the parameter sensitivity analyses and how the resultant CCDP changed from the base case value of  $5.4 \times 10^{-6}$  as a result of single parameter changes. In all cases, the base case values were increased by a factor of x 5.0 which is considered to be a maximum upper bound value.

Sensitivity Study	Modification	CCDP <sup>1</sup>
1	<b>RPV-XHE-LEVEL</b> (Failure of Operators to restore RPV level) failure probability increased by x 5.0	$2.6 \times 10^{-4}$
2	<b>HCS-MDP-TM-TRAIN</b> (HPCS Pump test/maintenance unavailability) unavailability increased by x 5.0	$1.2 \times 10^{-4}$
3	<b>HCS-MDP-FS-HPCS</b> (HPCS Pump fails to start) failure probability increased by x 5.0	$6.9 \times 10^{-5}$

Note 1: CCDP sensitivity study calculations are based on point estimate values.

The conclusion from these sensitivity studies is that relatively large changes in the most sensitive base event probability values results in effects that are within the 90% bounds.

## References

1. David N. Norfing (Entergy), "Unplanned Automatic SCRAM Due to Loss of Non-Vital 120V Instrument Bus", LER 458/04-005-01, issued June 22, 2005, ML051790232.
2. David N. Graves (USNRC) to Paul D. Hinnenkamp (Entergy), "River Bend Station - NRC Integrated Inspection Report 05000458/2004005, issued February 14, 2005, ML050450486.
3. Robert Buell and John Schroeder (INEL), "Standardized Plant Analysis Risk Model for River Bend (ASP BWR C)" Revision 3.12, issued August 24, 2005.
4. Entergy, "River Bend Station Updated Safety Analysis Report", Revision 17, issued August 27, 2000.



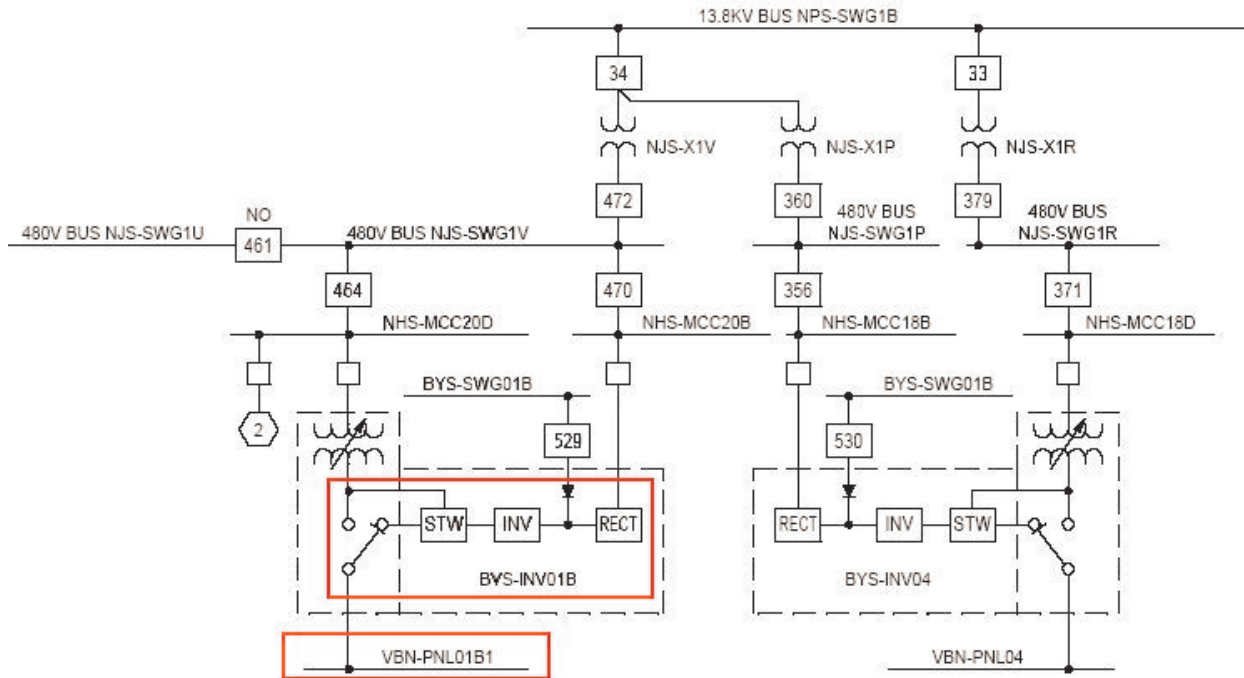
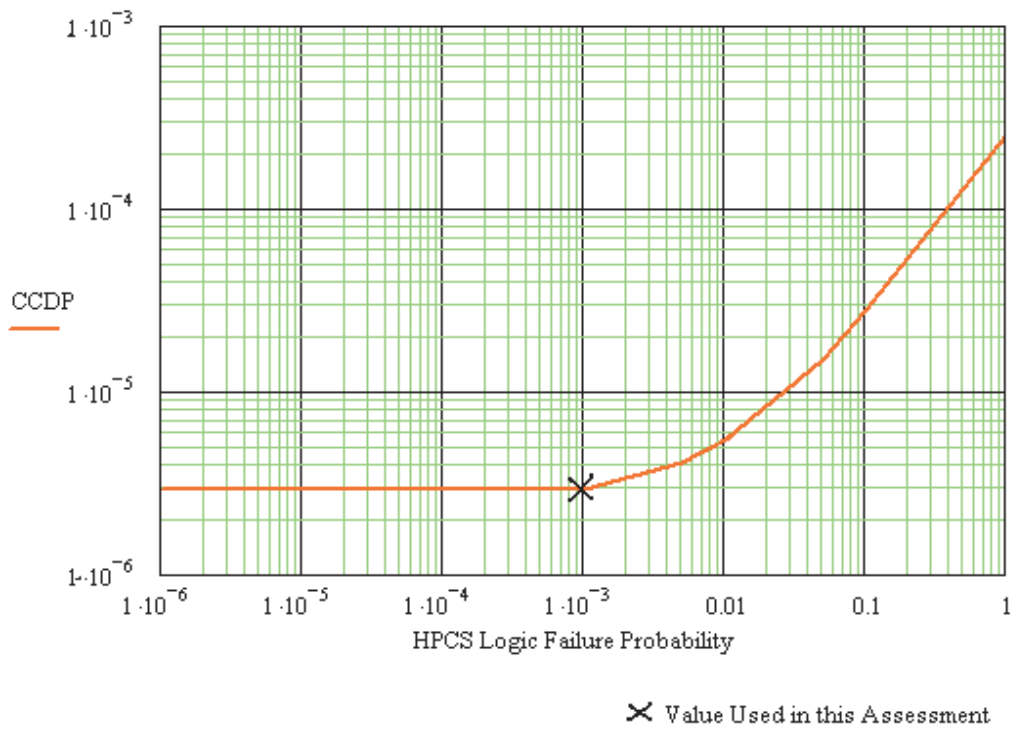

Figure 1. River Bend Station 120V Non-Vital Instrument Bus



**Figure 2. Results of CCDP Sensitivity Study on HPCS Logic Failure Probability**

**Table 1. Conditional core damage probabilities of dominating sequences.**

Event tree name	Sequence no.	CCDP <sup>1</sup>	Contribution
TRAN	56	$2.7 \times 10^{-5}$	99%
<b>Total (all sequences)<sup>2</sup></b>		<b><math>2.7 \times 10^{-5}</math></b>	<b>100%</b>

1. Values are point estimates.

2. Total CCDP includes all sequences (including those not shown in this table).

**Table 2a. Event tree sequence logic for dominant sequence.**

Event tree name	Sequence no.	Logic (“/” denotes success; see Table 2b for top event names)
TRAN	56	/RPS /SRV MFW HCS RCI DEP

**Table 2b. Definitions of top events listed in Table 2a.**

Top Event	Definition
RPS	REACTOR SHUTDOWN FAILS
SRV	ONE OR MORE SRVS FAIL TO CLOSE
HCS	HPCS FAILS TO PROVIDE SUFFICIENT FLOW TO RX VESSEL
MFW	MAIN FEEDWATER
RCI	REACTOR CORE ISOLATION COOLING
DEP	MANUAL DEPRESSURIZATION FAILS

**Table 3a. Conditional cut sets for the dominant sequences.**

CCDP	Percent Contribution	Minimum Cut Sets (of basic events)	
<b>Event Tree: TRAN Sequence 56</b>			
1.8E-005	65.03	HCS-MDP-TM-TRAIN	RPV-XHE-LEVEL
3.8E-006	13.94	HCS-MDP-FS-HPCS	RPV-XHE-LEVEL
2.5E-006	9.29	HCS-MOV-CC-INJEC	RPV-XHE-LEVEL
1.5E-006	5.57	HCS-MOV-FT-SUCTR	RPV-XHE-LEVEL
1.3E-006	4.78	HCS-MDP-FR-HPCS	RPV-XHE-LEVEL
<b>2.7 x 10<sup>-5</sup></b>	<b>99%</b>	<b>Total (all cutsets)<sup>1</sup></b>	

1. Total Importance includes all cutsets (including those not shown in this table).

**Table 4. Definitions and probabilities for modified and dominant basic events.**

Event Name	Description	Probability/Frequency (per year)	Modified
HCS-MDP-FR-HPCS	HPCS PUMP FAILS TO RUN	5.2E-004	
HCS-MDP-FS-HPCS	HPCS PUMP FAILS TO START	1.5E-003	
HCS-MDP-TM-TRAIN	HPCS IS UNAVAILABLE BECAUSE OF MAINTENANCE	7.0E-003	
HCS-MOV-CC-INJEC	HPCS INJECTION VALVE FAILS TO OPEN	1.0E-003	
HCS-MOV-FT-SUCTR	HPCS SUCTION TRANSFER FAILS	6.0E-004	
HCS-XHE-XM-RCOOL	OPERATOR FAILS TO ESTABLISH ROOM COOLING WITH	1.0E-003	
HPCS-LOGIC-FAILURE	FAILURE OF HPCS ½ TAKEN TWICE AUTOSTART LOG	1.0E-003	YES(1)
IE-IORV	INADVERTENT/STUCK OPEN RELI	1.5E-002 +0.0E+000	FALSE YES
IE-ISL-RHR	ISLOCA IE 2-MOV RHR interfac	1.4E-007 +0.0E+000	FALSE YES
IE-LLOCA	LARGE LOCA	3.0E-005 +0.0E+000	FALSE YES
IE-LOCHS	LOSS OF CONDENSER HEAT SINK	2.0E-001 +0.0E+000	FALSE YES

Event Name	Description	Probability/Frequency (per year)	Modified
IE-LOIA	LOSS OF INSTRUMENT AIR	6.0E-003 +0.0E+000	FALSE YES
IE-LOMFW	LOSS OF FEEDWATER	1.0E-001 +0.0E+000	FALSE YES
IE-LOOP	LOSS OF OFFSITE POWER	0	FALSE YES
IE-MLOCA	MEDIUM LOCA	4.0E-005 +0.0E+000	FALSE YES
IE-SLOCA	SMALL LOCA	4.0E-004 +0.0E+000	FALSE YES
IE-TDCB	LOSS OF VITAL DC BUS	2.5E-003 +0.0E+000	FALSE YES
IE-TMVB	LOSS OF VITAL MEDIUM VOLTAGE	4.0E-002 +0.0E+000	FALSE YES
IE-TRANS	GENERAL PLANT TRANSIENT	8.0E-001 1.0E+000	TRUE YES
IE-TSWS	LOSS OF SERVICE WATER	4.0E-004 +0.0E+000	FALSE YES
IE-XLOCA	EXCESSIVE LOCA (VESSEL RUPTU	1.0E-007 +0.0E+000	FALSE YES
RPV-XHE-LEVEL	OPERATORS FAIL TO CONTROL RPV LEVEL	2.5E-003	YES(2)

NOTES:

1. Value is a conservative estimate of HPCS logic performance
2. Value is based on Human Reliability Analysis - See Appendix D.

**Appendix A**

**Event Tree Models**

**Showing Dominant Sequences**

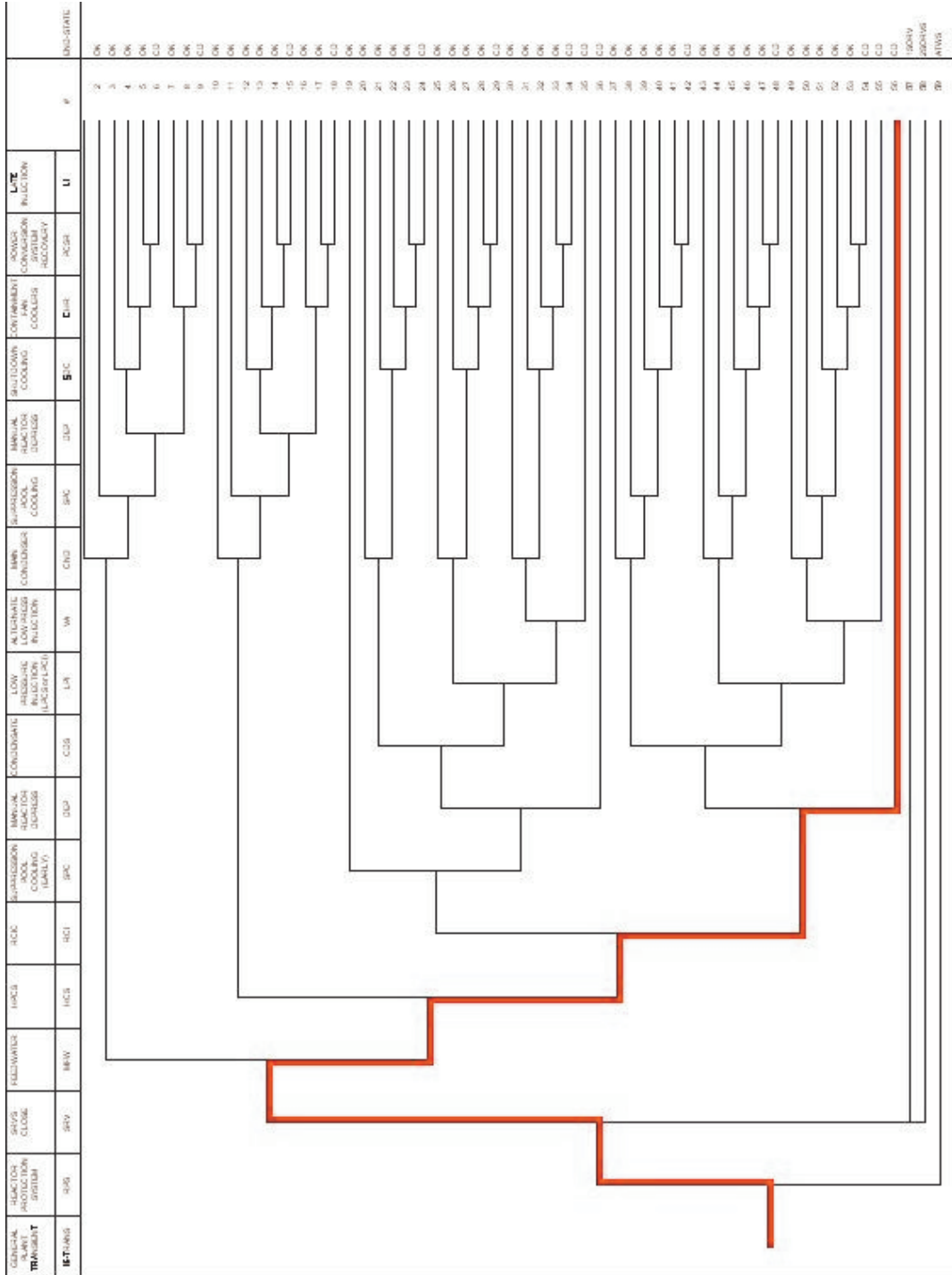

Figure A-1. Transient Event Tree Showing Dominant Sequence

## **Appendix B**

### **Fault Tree Models Showing Changes**



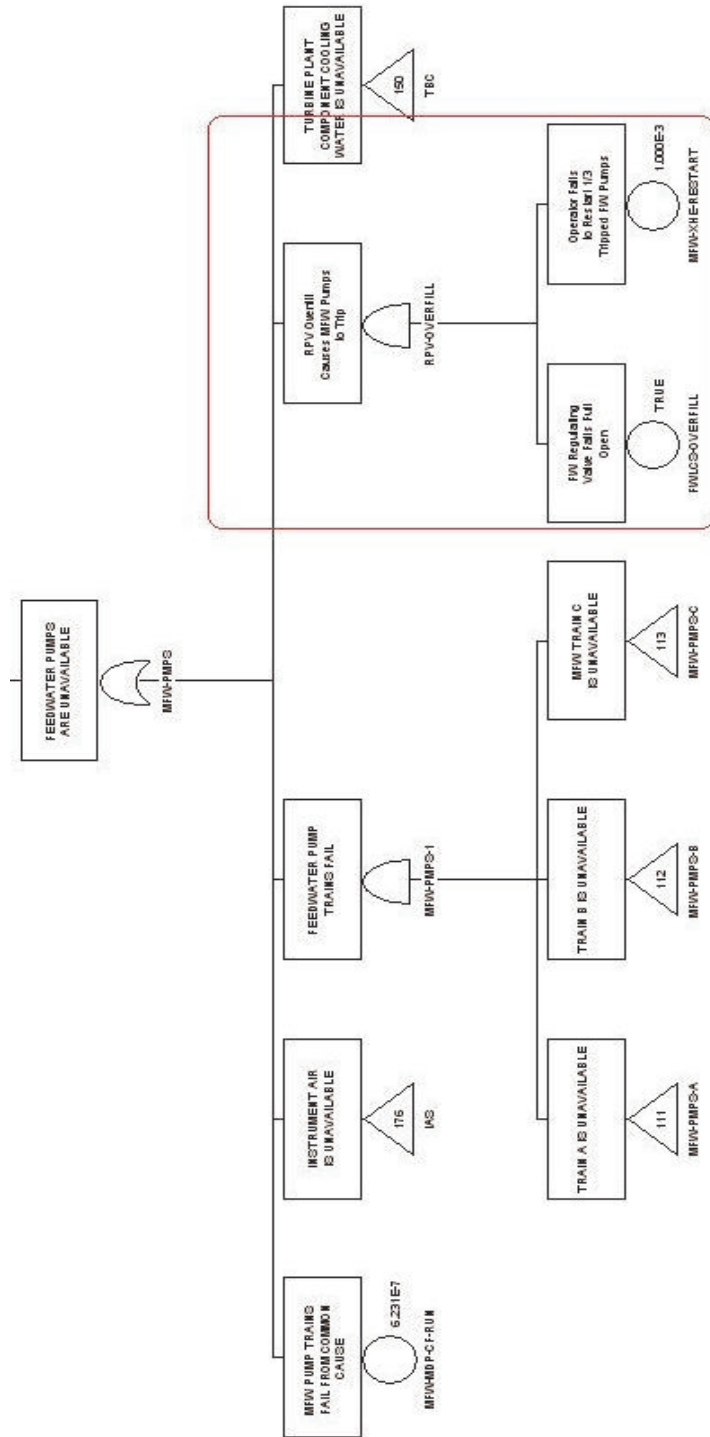

Figure B-1. Feedwater Fault Tree Showing Modifications

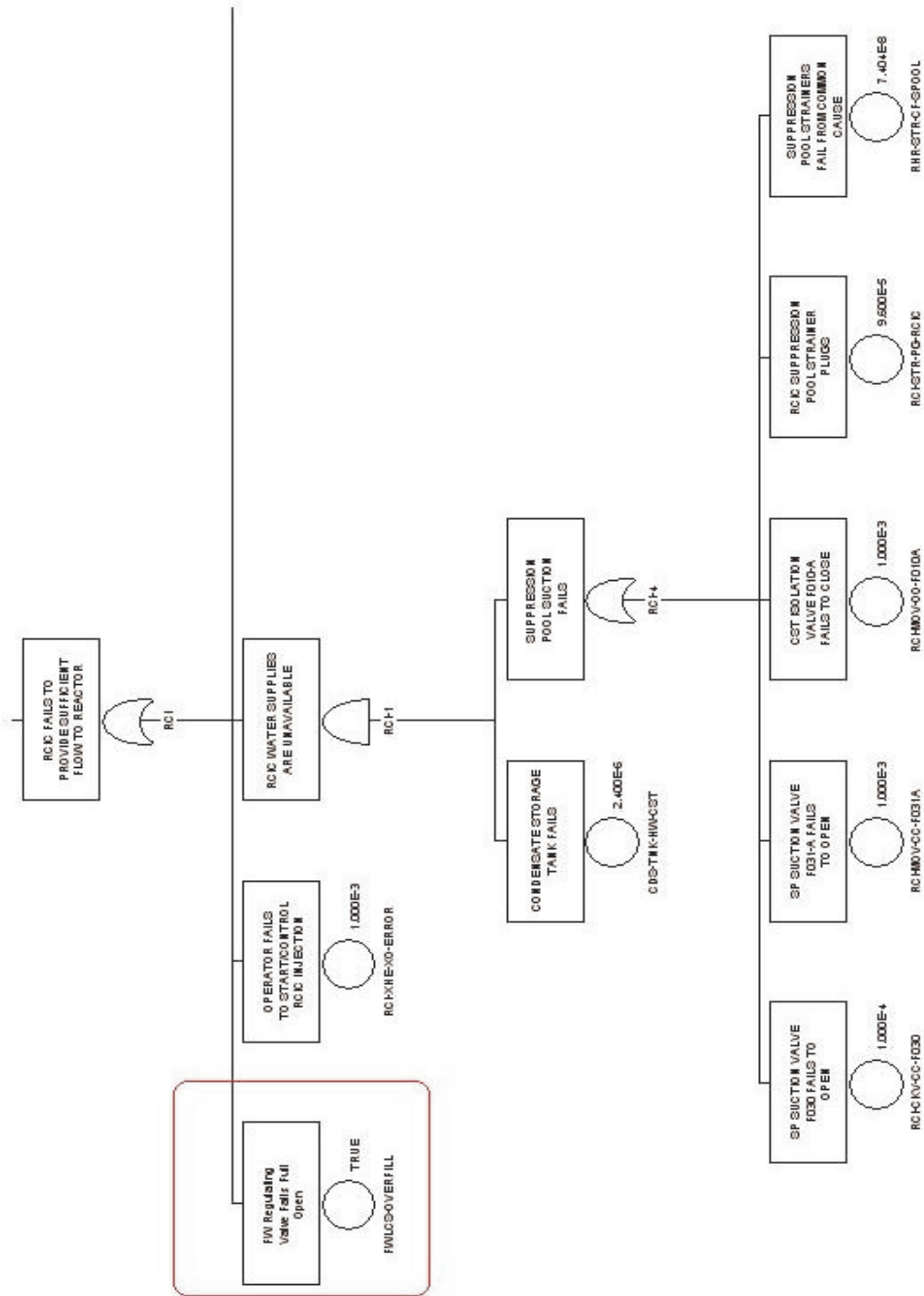

Figure B-2. RCIC Fault Tree Showing Modifications

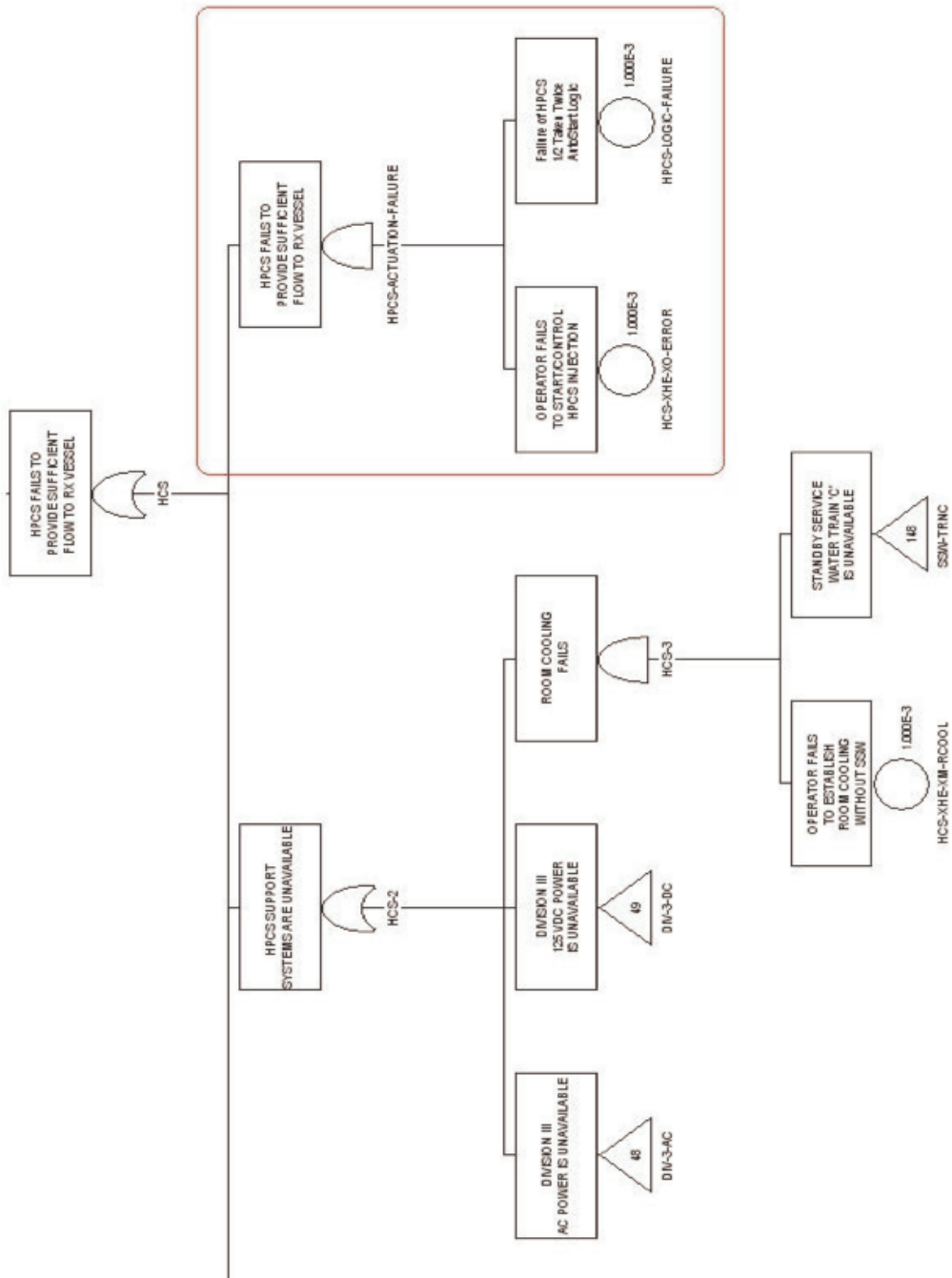

Figure B-3. HPCS Fault Tree Showing Modifications

## **Appendix C**

# **Modifications to SPAR Sequence Cutset Recovery Rules**

| TECH SPEC SECTION -----

| The following rule removes maintenance combinations prohibited by Tech Specs. The logic  
| was generated using the ME-TECHSPECS fault tree. Cutset removal using the rules here is  
| much faster than using ME-TECHSPECS as a mutually exclusive top event.

|  
if (SSW-MDP-TM-TRND \* SSW-MDP-TM-TRNA +  
SSW-MDP-TM-TRND \* SSW-MDP-TM-TRNB +  
SSW-MDP-TM-TRNA \* SSW-MDP-TM-TRNB +  
SSW-MDP-TM-TRND \* SSW-MDP-TM-TRNC +  
SSW-MDP-TM-TRNA \* SSW-MDP-TM-TRNC +  
SSW-MDP-TM-TRNB \* SSW-MDP-TM-TRNC +  
LCS-MDP-TM-TRAIN \* SSW-MDP-TM-TRNC +  
SSW-MDP-TM-TRNA \* RHR-MDP-TM-TRNB \* RHR-MDP-TM-TRNC +  
SSW-MDP-TM-TRNA \* EPS-DGN-TM-DGB +  
SSW-MDP-TM-TRNC \* RHR-MDP-TM-TRNB \* RHR-MDP-TM-TRNC +  
SSW-MDP-TM-TRNC \* EPS-DGN-TM-DGB +  
SSW-MDP-TM-TRND \* RHR-MDP-TM-TRNA +  
SSW-MDP-TM-TRNB \* RHR-MDP-TM-TRNA +  
RHR-MDP-TM-TRNA \* RHR-MDP-TM-TRNB \* RHR-MDP-TM-TRNC +  
RHR-MDP-TM-TRNA \* EPS-DGN-TM-DGB +  
SSW-MDP-TM-TRND \* EPS-DGN-TM-DGA +  
SSW-MDP-TM-TRNB \* EPS-DGN-TM-DGA +  
RHR-MDP-TM-TRNB \* RHR-MDP-TM-TRNC \* EPS-DGN-TM-DGA +  
EPS-DGN-TM-DGA \* EPS-DGN-TM-DGB +  
LCS-MDP-TM-TRAIN \* SSW-MDP-TM-TRNA \* RHR-MDP-TM-TRNB +  
LCS-MDP-TM-TRAIN \* RHR-MDP-TM-TRNA \* RHR-MDP-TM-TRNB +  
LCS-MDP-TM-TRAIN \* RHR-MDP-TM-TRNB \* EPS-DGN-TM-DGA +  
LCS-MDP-TM-TRAIN \* SSW-MDP-TM-TRNA \* RHR-MDP-TM-TRNC +  
LCS-MDP-TM-TRAIN \* RHR-MDP-TM-TRNA \* RHR-MDP-TM-TRNC +  
LCS-MDP-TM-TRAIN \* RHR-MDP-TM-TRNC \* EPS-DGN-TM-DGA +  
SSW-MDP-TM-TRND \* LCS-MDP-TM-TRAIN +  
LCS-MDP-TM-TRAIN \* SSW-MDP-TM-TRNB +  
LCS-MDP-TM-TRAIN \* RHR-MDP-TM-TRNB \* RHR-MDP-TM-TRNC +  
LCS-MDP-TM-TRAIN \* EPS-DGN-TM-DGB +  
RCI-TDP-TM-TRAIN \* SSW-MDP-TM-TRNC +  
CCS-ACX-TM-FANA \* CCS-ACX-TM-FANB +  
CCS-ACX-TM-FANA \* CCS-ACX-TM-FANC +  
CCS-ACX-TM-FANB \* CCS-ACX-TM-FANC +  
FWS-EDP-TM-TRNA \* FWS-EDP-TM-TRNB +  
SLC-MDP-TM-TRNA \* SLC-MDP-TM-TRNB +  
SLC-EPV-TM-TRNA \* SLC-EPV-TM-TRNB +  
LCS-MDP-TM-TRAIN \* EPS-DGN-TM-DGC +  
LCS-MDP-TM-TRAIN \* HCS-MDP-TM-TRAIN +  
RCI-TDP-TM-TRAIN \* EPS-DGN-TM-DGC +

```
RCI-TDP-TM-TRAIN * HCS-MDP-TM-TRAIN ) then
  DeleteRoot;
endif
```

```
|
| HEP DEPENDENCY RULES SECTION -----
|
```

```
|
| High Pressure Injection
|
```

```
zRCI = RCI-XHE-XO-ERROR;
zHCS = HCS-XHE-XO-ERROR;
```

```
if zRCI * zHCS then
  DeleteEvent = HCS-XHE-XO-ERROR;
  AddEvent    = HCS-XHE-XO-ERROR1;
endif
```

```
|
| Early Low-Pressure Injection
|
```

```
zCDS = CDS-XHE-XO-ERROR;
zVA  = OPR-XHE-XM-ALPI;
```

```
if zCDS * zVA then
  DeleteEvent = OPR-XHE-XM-ALPI;
  AddEvent    = OPR-XHE-XM-ALPI4;
endif
```

```
|
| Residual Heat Removal/Venting
|
```

```
| No dependent event substitutions required.
```

```
|
| Late Low-Pressure Injection
|
```

```
zCRD = CRD-XHE-XM-VLVS + CRD-XHE-XM-PUMP;
zVA1 = OPR-XHE-XM-ALPI1;
zVA2 = OPR-XHE-XM-ALPI2;
```

```
if zCRD * zVA1 then
  DeleteEvent = OPR-XHE-XM-ALPI1;
  AddEvent    = OPR-XHE-XM-ALPI5;
elsif zCRD * zVA2 then
  DeleteEvent = OPR-XHE-XM-ALPI2;
  AddEvent    = OPR-XHE-XM-ALPI6;
elsif zCDS * zVA2 then
  DeleteEvent = OPR-XHE-XM-ALPI2;
  AddEvent    = OPR-XHE-XM-ALPI7;
endif
```

```
if ADS-XHE-XM-MDEPR * MFW-XHE-RESTART then
  DeleteEvent = ADS-XHE-XM-MDEPR;
  DeleteEvent = MFW-XHE-RESTART;
  AddEvent    = RPV-XHE-LEVEL;
endif
```

```
if ADS-XHE-XM-MDEPR * HCS-XHE-XO-ERROR then
  DeleteEvent = ADS-XHE-XM-MDEPR;
  DeleteEvent = HCS-XHE-XO-ERROR;
  AddEvent    = RPV-XHE-LEVEL;
endif
```

**Appendix D**

**Human Reliability Analysis**



HRA Worksheets for At-Power  
SPAR HUMAN ERROR WORKSHEET

Plant: River Bend Initiating Event: IE-TRANS Basic Event: RPV-XHE-LEVEL

Event Coder: John Bickel

**Basic Event Context:** Failure to Restore, Maintain post-trip RPV water level using some combination of feedwater, RCIC, HPCS - or - manual depressurization and use of: LPCS, LPCI, or condensate pumps

**Basic Event Description:** Failure to Restore, Maintain post-trip RPV water level

Does this task contain a significant amount of diagnosis activity? YES  (start with Part I - Diagnosis) NO  (skip Part I - Diagnosis; start with Part II - Action) Why? \_\_\_\_\_

**PART I. EVALUATE EACH PSF FOR DIAGNOSIS**

**A. Evaluate PSFs for the Diagnosis Portion of the Task, if any.**

Reviewer: \_\_\_\_\_

PSFs	PSF Levels	Multiplier for Diagnosis	Please note specific reasons for PSF level selection in this column.
Available Time	Inadequate time	P(failure) = 1.0 <input type="checkbox"/>	From a condition of high RPV water level, there is substantial additional time for the operators to make a decision on restoring water level and selecting the pumps to accomplish the intent of the procedures.
	Barely adequate time ( $\approx 2/3$ x nominal)	10 <input type="checkbox"/>	
	Nominal time	1 <input type="checkbox"/>	
	Extra time (between 1 and 2 x nominal and > than 30 min)	0.1 <input checked="" type="checkbox"/>	
	Expansive time (> 2 x nominal and > 30 min)	0.01 <input type="checkbox"/>	
	Insufficient information	1 <input type="checkbox"/>	
Stress/ Stressors	Extreme	5 <input type="checkbox"/>	
	High	2 <input type="checkbox"/>	
	Nominal	1 <input checked="" type="checkbox"/>	
	Insufficient Information	1 <input type="checkbox"/>	
Complexity	Highly complex	5 <input type="checkbox"/>	
	Moderately complex	2 <input type="checkbox"/>	
	Nominal	1 <input checked="" type="checkbox"/>	
	Obvious diagnosis	0.1 <input type="checkbox"/>	
	Insufficient information	1 <input type="checkbox"/>	
Experience/ Training	Low	10 <input type="checkbox"/>	Operators routinely drill on RPV level restoration procedure in simulator training
	Nominal	1 <input type="checkbox"/>	
	High	0.5 <input checked="" type="checkbox"/>	
	Insufficient information	1 <input type="checkbox"/>	
Procedures	Not available	50 <input type="checkbox"/>	RPV level restoration procedure is based on BWROG emergency procedure guidelines which are symptom oriented.
	Incomplete	20 <input type="checkbox"/>	
	Available, but poor	5 <input type="checkbox"/>	
	Nominal	1 <input type="checkbox"/>	
	Diagnostic/symptom oriented	0.5 <input checked="" type="checkbox"/>	
	Insufficient information	1 <input type="checkbox"/>	

Reviewer: \_\_\_\_\_

PSFs	PSF Levels	Multiplier for Diagnosis	Please note specific reasons for PSF level selection in this column.
Ergonomics/ HMI	Missing/Misleading	50 <input type="checkbox"/>	The combination of off-scale high RPV level readings with failed off-scale low RPV level readings caused by the 120V instrument bus loss contributed to some confusion but operators went ahead with use of HPCS to maintain RPV level based upon symptoms.
	Poor	10 <input checked="" type="checkbox"/>	
	Nominal	1 <input type="checkbox"/>	
	Good	0.5 <input type="checkbox"/>	
	Insufficient Information	1 <input type="checkbox"/>	
Fitness for Duty	Unfit	P(failure) = 1.0 <input type="checkbox"/>	
	Degraded Fitness	5 <input type="checkbox"/>	
	Nominal	1 <input checked="" type="checkbox"/>	
	Insufficient information	1 <input type="checkbox"/>	
Work Processes	Poor	2 <input type="checkbox"/>	
	Nominal	1 <input checked="" type="checkbox"/>	
	Good	0.8 <input type="checkbox"/>	
	Insufficient information	1 <input type="checkbox"/>	

Reviewer: \_\_\_\_\_

Plant: River Bend    Initiating Event: IE-TRANS    Basic Event: RPV-XHE-LEVEL

Event Coder: \_\_\_\_\_

**Basic Event Context:** Failure to Restore, Maintain post-trip RPV water level using some combination of feedwater, RCIC, HPCS - or - manual depressurization and use of: LPCS, LPCI, or condensate pumps

**Basic Event Description:** Failure to Restore, Maintain post-trip RPV water level

**B. Calculate the Diagnosis Failure Probability.**

- (1) If all PSF ratings are nominal, then the Diagnosis Failure Probability = 1.0E-2
- (2) Otherwise, the Diagnosis Failure Probability is: 1.0E-2 x Time x Stress or Stressors x Complexity x Experience or Training x Procedures x Ergonomics or HMI x Fitness for Duty x Processes

Diagnosis: 1.0E-2 x 0.1 x 1.0 x 1.0 x 0.5 x 0.5 x 10 x 1.0 x 1.0 = 2.5E-3

**C. Calculate the Adjustment Factor IF Negative Multiple (≥ 3) PSFs are Present.**

When 3 or more negative PSF influences are present, in lieu of the equation above, you must compute a composite PSF score used in conjunction with the adjustment factor. Negative PSFs are present anytime a multiplier greater than 1 is selected. The Nominal HEP (NHEP) is 1.0E-2 for Diagnosis. The composite PSF score is computed by multiplying all the assigned PSF values. Then the adjustment factor below is applied to compute the HEP:

$$HEP = \frac{NHEP \cdot PSF_{composite}}{NHEP \cdot (PSF_{composite} - 1) + 1}$$

Diagnosis HEP with Adjustment Factor = N/A

**D. Record Final Diagnosis HEP.**

If no adjustment factor was applied, record the value from Part B as your final diagnosis HEP. If an adjustment factor was applied, record the value from Part C.

Final Diagnosis HEP = 1.25E-2

Reviewer: \_\_\_\_\_

Plant: River Bend Initiating Event: IE-TRANS Basic Event: RPV-XHE-LEVEL

Event Coder: John Bickel

**Basic Event Context:** Failure to Restore, Maintain post-trip RPV water level using some combination of feedwater, RCIC, HPCS - or - manual depressurization and use of: LPCS, LPCI, or condensate pumps

**Basic Event Description:** Failure to Restore, Maintain post-trip RPV water level

**PART II. EVALUATE EACH PSF FOR ACTION**

**A. Evaluate PSFs for the Action Portion of the Task, if any.**

PSFs	PSF Levels	Multiplier for Diagnosis	Please note specific reasons for PSF level selection in this column.
Available Time	Inadequate time	P(failure) = 1.0 <input type="checkbox"/>	The required actions: starting HPCS, a feedwater pump, depressurizing and starting LPCS or LPCI are relatively simple and quick to undertake once a decision has been reached to do so.
	Time available is ≈ the time required	10 <input type="checkbox"/>	
	Nominal time	1 <input type="checkbox"/>	
	Time available ≥ 5x the time required	0.1 <input type="checkbox"/>	
	Time available is ≥ 50x the time required	0.01 <input checked="" type="checkbox"/>	
	Insufficient information	1 <input type="checkbox"/>	
Stress/ Stressors	Extreme	5 <input type="checkbox"/>	
	High	2 <input type="checkbox"/>	
	Nominal	1 <input checked="" type="checkbox"/>	
	Insufficient Information	1 <input type="checkbox"/>	
Complexity	Highly complex	5 <input type="checkbox"/>	
	Moderately complex	2 <input type="checkbox"/>	
	Nominal	1 <input checked="" type="checkbox"/>	
	Insufficient information	1 <input type="checkbox"/>	
Experience/ Training	Low	3 <input type="checkbox"/>	Operators regularly drill on RPV level restoration post-trip.
	Nominal	1 <input type="checkbox"/>	
	High	0.5 <input checked="" type="checkbox"/>	
	Insufficient information	1 <input type="checkbox"/>	

Reviewer: \_\_\_\_\_

PSFs	PSF Levels	Multiplier for Diagnosis	Please note specific reasons for PSF level selection in this column.
Procedures	Not available	50 <input type="checkbox"/>	
	Incomplete	20 <input type="checkbox"/>	
	Available, but poor	5 <input type="checkbox"/>	
	Nominal	1 <input checked="" type="checkbox"/>	
	Insufficient information	1 <input type="checkbox"/>	
Ergonomics/ HMI	Missing/Misleading	50 <input type="checkbox"/>	
	Poor	10 <input type="checkbox"/>	
	Nominal	1 <input checked="" type="checkbox"/>	
	Good	0.5 <input type="checkbox"/>	
	Insufficient Information	1 <input type="checkbox"/>	
Fitness for Duty	Unfit	P(failure) = 1.0 <input type="checkbox"/>	
	Degraded Fitness	5 <input type="checkbox"/>	
	Nominal	1 <input checked="" type="checkbox"/>	
	Insufficient information	1 <input type="checkbox"/>	
Work Processes	Poor	5 <input type="checkbox"/>	
	Nominal	1 <input checked="" type="checkbox"/>	
	Good	0.5 <input type="checkbox"/>	
	Insufficient information	1 <input type="checkbox"/>	

Reviewer: \_\_\_\_\_

Plant: River Bend    Initiating Event: IE-TRANS    Basic Event: RPV-XHE-LEVEL

Event Coder: \_\_\_\_\_

**Basic Event Context:** Failure to Restore, Maintain post-trip RPV water level using some combination of feedwater, RCIC, HPCS - or - manual depressurization and use of: LPCS, LPCI, or condensate pumps

**Basic Event Description:** Failure to Restore, Maintain post-trip RPV water level

**B. Calculate the Action Failure Probability.**

- (1) If all PSF ratings are nominal, then the Action Failure Probability = 1.0E-3
- (2) Otherwise, the Action Failure Probability is: 1.0E-3 x Time x Stress or Stressors x Complexity x Experience or Training x Procedures x Ergonomics or HMI x Fitness for Duty x Processes

Action:  $1.0E-3 \times 0.01 \times 1.0 \times 1.0 \times 0.5 \times 1.0 \times 1.0 \times 1.0 \times 1.0 =$  5.0E-6

**C. Calculate the Adjustment Factor IF Negative Multiple ( $\geq 3$ ) PSFs are Present.**

When 3 or more negative PSF influences are present, in lieu of the equation above, you must compute a composite PSF score used in conjunction with the adjustment factor. Negative PSFs are present anytime a multiplier greater than 1 is selected. The Nominal HEP (NHEP) is 1.0E-3 for Action. The composite PSF score is computed by multiplying all the assigned PSF values. Then the adjustment factor below is applied to compute the HEP:

$$HEP = \frac{NHEP \cdot PSF_{composite}}{NHEP \cdot (PSF_{composite} - 1) + 1}$$

Action HEP with Adjustment Factor = N/A

**D. Record Final Action HEP.**

If no adjustment factor was applied, record the value from Part B as your final action HEP. If an adjustment factor was applied, record the value from Part C.

Final Action HEP = 5.0E-6

Reviewer: \_\_\_\_\_

Plant: River Bend    Initiating Event: IE-TRANS    Basic Event: RPV-XHE-LEVEL

Event Coder: \_\_\_\_\_

**Basic Event Context:** Failure to Restore, Maintain post-trip RPV water level using some combination of feedwater, RCIC, HPCS - or - manual depressurization and use of: LPCS, LPCI, or condensate pumps

**Basic Event Description:** Failure to Restore, Maintain post-trip RPV water level

**PART III. CALCULATE TASK FAILURE PROBABILITY WITHOUT FORMAL DEPENDENCE**  
( $P_{w/OD}$ )

Calculate the Task Failure Probability Without Formal Dependence ( $P_{w/od}$ ) by adding the Diagnosis Failure Probability from Part I and the Action Failure Probability from Part II. In instances where an action is required without a diagnosis and there is no dependency, then this step is omitted.

$$P_{w/od} = \text{Diagnosis HEP } \underline{2.5E-3} + \text{Action HEP } \underline{5.0E-6} = \boxed{2.5E-3}$$

**Part IV. DEPENDENCY**

For all tasks, except the first task in the sequence, use the table and formulae below to calculate the Task Failure Probability With Formal Dependence ( $P_{w/d}$ ).

If there is a reason why failure on previous tasks should not be considered, such as it is impossible to take the current action unless the previous action has been properly performed, explain here: \_\_\_\_\_

**NOTE: RPV Level Restoration is the first operator action modeled.**

Reviewer: \_\_\_\_\_



Condition Number	Crew (same or different)	Time (close in time or not close in time)	Location (same or different)	Cues (additional or no additional)	Dependency	Number of Human Action Failures Rule □ - Not Applicable. Why? _____
1	s	c	s	na	complete	When considering recovery in a series e.g., 2 <sup>nd</sup> , 3 <sup>rd</sup> , or 4 <sup>th</sup> checker  If this error is the <b>3<sup>rd</sup> error in the sequence</b> , then the dependency is at least <b>moderate</b> .  If this error is the <b>4<sup>th</sup> error in the sequence</b> , then the dependency is at least <b>high</b> .
2				a	complete	
3			d	na	high	
4				a	high	
5		nc	s	na	high	
6				a	moderate	
7			d	na	moderate	
8				a	low	
9	d	c	s	na	moderate	
10				a	moderate	
11			d	na	moderate	
12				a	moderate	
13		nc	s	na	low	
14				a	low	
15			d	na	low	
16				a	low	
17					zero	

Using  $P_{w/od}$  = Probability of Task failure Without Formal Dependence (calculated in Part III):

- For Complete Dependence the probability failure is 1.
- For High Dependence the probability of failure is  $(1 + P_{w/od}/2)$
- For Moderate Dependence the probability of failure is  $(1 + 6 \times P_{w/od})/7$
- For Low Dependence the probability of failure is  $(1 + 19 \times P_{w/od})/20$
- For Zero Dependence the probability of failure is  $P_{w/od}$

Calculate  $P_{w/d}$  using the appropriate values:

$$P_{w/d} = (1 + (\text{_____} * \text{_____}))/\text{_____} = \boxed{\phantom{000}}$$