



BWR steam dryer integrity

SIL No. 644 Revision 1

November 9, 2004

SIL No. 644 (“BWR/3 steam dryer failure”), issued August 21, 2002, described an event at a BWR/3 that involved the failure of a steam dryer cover plate resulting in the generation of loose parts, which were ingested into a main steam line (MSL). The most likely cause of this event was identified as high cycle fatigue caused by a flow regime instability that resulted in localized high frequency pressure loadings near the MSL nozzles. SIL No. 644 Supplement 1, issued September 5, 2003, described a second steam dryer failure that occurred at the same BWR/3 approximately one year following the initial steam dryer failure. This second failure occurred at a different location with the root cause identified as high cycle fatigue resulting from low frequency pressure loading. SIL No. 644 included focused recommendations. For BWR/3-style steam dryers, it recommended monitoring steam moisture content (MC) and other reactor parameters, and for those plants operating at greater than the original licensed thermal power (OLTP), it recommended inspection of the cover plates at the next refueling outage. SIL No. 644 Supplement 1 broadened the earlier recommendations for BWR/3-style steam dryer plants and provided additional recommendations for BWR/4 and later steam dryer design plants planning to or already operating at greater than OLTP.

Following this revised guidance, inspections were performed on plants operating at OLTP, stretch uprate (5%), and extended power uprate conditions. These inspections indicate that steam dryer fatigue cracking can also occur in plants operating at OLTP.

The purpose of this Revision 1 to SIL No. 644 is to describe additional significant fatigue cracking that has been observed in steam dryer hoods subsequent to the issuance of SIL No. 644 Supplement 1 and to provide inspection and

monitoring recommendations for all BWR plants based on these observations. In that the occurrence of fatigue cracking has been observed in several BWRs, this revision contains inspection and monitoring recommendations that apply to all plants. SIL No. 644 Revision 1 voids and supercedes SIL No. 644 and SIL No. 644 Supplement 1.

Discussion

Instances of fatigue cracking in the steam dryer hood region have been observed recently in several BWR plants. The cracking has led to failure of the hood and the generation of loose parts in two BWR/3 plants. Details of the cracking in these plants are described below. These observations have potential generic significance for all BWR steam dryers that will be discussed in the generic implications section below.

BWR/3-Style Dryer Observations

Lower horizontal cover plate failure occurred in a BWR/3 in 2002. In this failure, almost the entire lower horizontal cover plate came completely loose, with some large pieces falling down onto the steam separators and one piece being ingested into the main steamline and lodging in the flow restrictor. This failure was accompanied by a significant increase in moisture content, along with changes in other monitored reactor parameters. The cause of this failure was attributed to the higher fluctuating pressure loads at extended power uprate (EPU) operation. In particular, there may have been a potential resonance condition between a high frequency fluctuating pressure loading (in the 120-230 Hz range) and the natural frequency of the cover plate. Appendix A provides a more detailed description of this event.

The same BWR/3 experienced extensive through-wall cracking in the outer bank hood on

the 90° side in May 2003. On the opposite side of the steam dryer (270° side), incipient cracking was observed on the inside of the outer hood cover plate. Several internal braces were detached and found on top of the steam separators. No damage was found on the inner banks of the dryer. Again, the failure was accompanied by a significant increase in moisture content. Of the other monitored reactor parameters, only the flow distribution between the individual steamlines was affected. The cause of this failure was attributed to high cycle fatigue resulting from low frequency oscillating pressure loads (<50 Hz) of higher amplitude at EPU operation and the local stress concentration introduced by the internal brackets that anchor the diagonal internal braces to the dryer hoods. Appendix B provides a more detailed description of this event.

In November 2003, a hood failure occurred in the sister unit to the BWR/3 that had experienced the previously noted failures. This unit was also operating at EPU conditions. The observed hood damage and associated root cause determination were virtually the same as the May 2003 failure described above. During the event, the moisture content exceeded the previously defined action level. However, the monitored plant parameters (primarily individual steamline flow rates) showed only subtle changes and were well within the previously defined action levels for the plant. This failure resulted in the generation of loose parts from the outer vertical hood plate. In addition, inspections during the repair outage showed fatigue cracking in the inner hood vertical braces below where the lower ends of the diagonal braces were attached. The cracking of these braces was attributed to poor fit-up of the parts during the dryer fabrication. The diagonal braces should have terminated on the vertical braces where they were butted up against the drain trough, which would have transferred the diagonal brace loads directly to the drain trough. Instead, the diagonal braces terminated on the vertical braces above the top of the drain trough and the diagonal brace loads were transmitted

through the unsupported section of the vertical braces, thus overstressing the vertical braces.

In October 2003 and December 2003, inspections were made of the steam dryers of the sister units to the BWR/3s described above at another site. These units had also been operating at EPU conditions. Incipient cracking was observed on the inside of the outer hood vertical plates on each of the outer dryer banks. At one location, the cracking had grown through-wall. The cracking was also attributed to high cycle fatigue resulting from low frequency pressure loading.

In March 2004, inspections were performed of the repairs made to the BWR/3 dryer in 2003. Incipient fatigue cracks were found at the tips of the external reinforcing gussets that were added as part of the 2003 repairs. Fatigue cracks were also found in tie bars that were reinforced during the 2003 repairs. The cracking in these repairs was attributed to local stress concentration introduced by the as-installed repairs. In both cases, the local stress concentrations had not been modeled in sufficient detail in the analyses that supported the repair design. Fatigue cracks were also found in perforated plate insert modifications that were made in 2002 as part of the extended power uprate implementation. These cracks were also attributed to the displacements and stresses imposed by the dryer banks that caused the tie bar cracking.

In April 2004, inspections were made of a BWR/3-style dryer (square hood) in a BWR/4 plant in preparation for implementing an extended power uprate during the upcoming cycle. This inspection found cracking at two diametrically opposed locations on the exterior steam dam near the lifting lug. Both cracks were similar in length. The cause of the cracking was not identified. It has been postulated that the crack initiation was due to high residual stresses generated during the dryer fabrication process. The structural analysis of the steam dryer for EPU conditions did not predict these locations as highly susceptible to fatigue cracking. Two other symmetrical

locations in the steam dryer that experienced the same loading conditions did not exhibit any evidence of cracking. These observations point to the likelihood of the presence of an additional contributing factor aside from the pressure loads during normal operation. Specifically, the evidence indicates that a high residual stress condition was probably developed by the original dryer fabrication welding sequence. Other “cold spring” type loading could also have been generated during the fabrication process. After the cracking developed, the residual stresses would have been relieved and the crack growth would have subsided.

BWR/5-Style Dryer Observation

In March 2004, inspection of the steam dryer at a BWR/5 revealed a fatigue crack in the hood panel to end plate weld. The hood crack occurred in the weld joint between the 1/8" curved hood and the 1/4" end plate on the second dryer bank. This particular weld location is vulnerable to fatigue cracking because of the small weld size associated with the thin 1/8" hood material. Fabrication techniques (e.g., feathering the 1/8" plate during fit-up) may further reduce the weld size. Fatigue cracking has been observed in the second bank hood-end plate weld at several other plants with the curved BWR/4-5 hood design at OLTP power levels. An undersized weld was determined to be the root cause of the cracking observed in at least two of the plants. Incorporating lessons learned from the weld cracks at the other plants, the dryer for this BWR/5 was built with an additional 1/4" fillet weld on the inside of the hood-end plate joint. This weld extended as high up in the hood as was practical for the welder to make (approximately 50") and spanned the probable initiation location for the earlier cracks. The weld crack at the subject BWR/5 occurred in the upper part of the 1/8" weld, above this reinforced section.

The weld joint between the 1/8" curved hood and the 1/4" end plate on the second dryer bank is a known high stress location for the BWR/4-5 curved hood dryer design; therefore, periodic

inspection of this location was recommended by SIL No. 644 Supplement 1. The hood cracks at the other four plants occurred early in plant life, within the first three or four cycles of operation. In-plant vibration testing of one of the cracked dryers showed that the dynamic pressure oscillations were high enough that the 1/8" hood to end plate weld was vulnerable to fatigue cracking at pre-uprate power levels. The hood crack at the subject BWR/5 occurred after approximately 16 years of operation, the last nine of which were at a 5% stretch uprate power level. While power uprate operation does increase the loading on the dryer, the length of operating time at uprated power levels before the cracking was observed indicates that the weld was not grossly overstressed and that power uprate was only a secondary factor in the cracking observed at the subject BWR/5.

BWR Fleet Operating History

Steam dryer cracking has been observed throughout the BWR fleet operating history. The operating environment has a significant influence on the susceptibility of the dryer to cracking. Most of the steam dryer is located in the steam space with the lower half of the skirt immersed in reactor water at saturation temperature. These environments are highly oxidizing and increase the susceptibility to IGSCC cracking. Average steam flow velocities through the dryer vanes at rated conditions are relatively modest (2 to 4 feet per second). However, local regions near the steam outlet nozzles may be continuously exposed to steam flows in excess of 100 feet per second. Thus, there is concern for fatigue cracking resulting from flow-induced vibration and fluctuating pressure loads acting on the dryer.

In addition to the recent instances described above, steam dryer cracking has been observed in the following components at several BWRs: dryer hoods, dryer hood end plates, drain channels, support rings, skirts, tie bars, and lifting rods. These crack experiences have predominately occurred during OLTP conditions, and are briefly described below.

Dryer Hood Cracking

As discussed above, outer hood cracking has occurred recently in square hood design dryers. Additionally, other hood cracking has occurred in the BWR operating fleet. Cracking of this type was first found in BWR/2s in the inner banks. These hood cracks were attributed to high cycle fatigue. Other cracking has since been observed in other types of dryers including BWR/4s and attributed to high cycle fatigue as well. Susceptible plants were typically reinforced with weld material or plates.

Dryer End Plate Cracking

Cracking has been detected in end plates of the dryer banks at several BWRs. These cracks have been attributed to IGSCC based on the location and morphology of the cracks. These cracks have been followed over several cycles and shown to be stable when operating conditions (power levels) are not changed. Typically no repairs have been necessary.

Drain Channel Cracking

Drain channel cracking has been found in all types of BWRs. This cracking has been primarily categorized as being attributable to fatigue, although many cracks have been attributed to IGSCC. The steam dryers were originally fabricated using Type 304 stainless steel, a material susceptible to sensitization by welding processes and prone to crack initiation in the presence of cold work. Drain channel cracking has been associated with at least 17 plants. The occurrence of the cracking prompted GE to issue SIL No. 474 (“Steam Dryer Drain Channel Cracking” issued October 26, 1988) after cracks were discovered in the drain channel attachment welds during routine visual examination of dryers at several BWR/4, 5 and 6 plants. The cracks generally were through the throat of vertical welds that attach the side of the drain channel to the exterior of the 0.25-inch thick dryer skirt. The cracks were as long as 21 inches. The cracks are thought to have originated at the bottom of the drain channel where there is maximum stress in the welds. The appearance of the cracking and

analysis of potential sources of stress on the welds indicate that high cycle fatigue initiated the cracks in drain channel welds. With the internal dryer inspections performed following the issuance of SIL No. 644, similar cracking has been observed in the internal drain channels of BWR/3-type steam dryers. Typically, drain channel cracks have been repaired by replacing and adding reinforcement weld material, stop-drilling the crack tip, or by replacing the drain channels.

Support Ring Cracking

Support ring cracking has been found in many BWRs. Cracking has been found in at least 19 plants, ranging from BWR/4s to BWR/6s. The cause of cracking has been IGSCC with a potential contributor being the cold working of the support ring during the fabrication process. These cracks are typically monitored for growth. To date, no repairs have been necessary since cracks have reached an arrested state.

Skirt

Skirt cracking has been found along with drain channel cracking. These cracks are either due to IGSCC or could be related to fatigue due to imposed local loads on the dryer. The cracking has also been found in the formed channel section of the dryer. The complex structural dynamic mode shapes of the dryer skirt, the stiffness added by the drain and guide channels, and residual weld stresses all contribute to the cracking observed in these components. Cracking in the dryer skirt region has been observed in plants operating at both OLTP and uprated power levels. Typically, repairs have been implemented at the time that cracking was found.

Tie Bar Cracking

Fatigue cracking has been observed in tie bars of plants operating at both OLTP and uprated power levels. In most cases, the potential for cracking is related to the cross section of the tie bar itself because the tie bar must withstand the displacements and stresses imposed by the dryer banks. Typically, repairs have been

implemented at the time that cracking was found.

Lifting Rod

Several plants have exhibited damage in the lifting rods. This cracking has often been in tack welds or in lateral brackets and has been attributed to fatigue.

Other Crack Locations

Other locations have also exhibited cracking. These locations include the level screws or leveling screw welds, seismic blocks, dryer bank end plates and internal attachment welds, vertical internal hood angle brackets and bottom plates.

Generic Implications

The steam dryer is a non-safety component. However, the structural integrity of the dryer must be maintained such that the generation of loose parts is prevented during normal operation, transients, and accident events. With the exception of the significant outer hood cracking at the two BWR/3 plants, the dryer cracking observed in the BWR fleet to date is unlikely to result in the generation of loose parts provided that a periodic inspection program is in place. However, given that the steam dryers operate in an environment that is conducive to crack initiation and that many plants are pursuing power uprates and operating license extensions, further cracking in steam dryers should be anticipated. Therefore, the material condition of the dryer should be actively managed to ensure that structural integrity is maintained throughout the life of the dryer.

The experience described above has several generic implications with respect to the susceptibility of steam dryers to fatigue or IGSCC cracking.

- o Fatigue cracking may result from stress concentrations inherent in the design of the dryer. The design of the BWR/3-style steam dryers with a square hood and internal braces results in maximum stresses where the internal braces attach to the outer hood.

The hood crack initiation at the BWR/3s described above occurred at these high stress locations. Also, the undersized hood-to-end plate welds on the BWR/5 curved hood dryers have cracked in several plants.

- o The actual dryer fabrication may have introduced stress concentrations that may lead to fatigue cracking. The poor fit-up of the diagonal and vertical braces in the BWR/3 dryer led to the cracking of the vertical braces. Feathering of the 1/8" plate during fit-up, and the corresponding reduction in weld area, was considered a contributing factor in the through-wall cracking of the hood-end plate weld in one of the BWR/5-style dryers. Residual stresses or "cold spring" introduced during the fabrication sequence may also lead to crack initiation.
- o The fabrication quality for each dryer may vary from one unit to the next, even if the dryers were built by the same fabricator to the same specifications.
- o The design of dryer repairs and modifications should consider the local stress concentrations that may be introduced by the modification design or installation. Repairs and modifications to the dryer should be inspected at each outage following the installation until structural integrity of the repairs and modifications can be confirmed.
- o Steam dryers are susceptible to IGSCC due to the material and fabrication techniques used in the dryer construction. Weld heat affected zone material is likely to be sensitized. Many dryer assembly welds have crevice areas at the weld root, which were not sealed from the reactor environment. Cold formed 304 stainless steel dryer parts were generally not solution annealed after forming and welding. Therefore, steam dryers are susceptible to IGSCC.

Parameter monitoring programs had been previously recommended with the intent of detecting structural degradation of the steam dryer during plant operation. The experience described above also has generic implications with respect to monitoring reactor system parameters during operation for the purposes of detecting steam dryer degradation.

- o The November 2003 BWR/3 hood failure demonstrated that monitoring steam moisture content and other reactor parameters does not consistently predict imminent dryer failure nor will it preclude the generation of loose parts. Monitoring is still useful in that it does allow identification of a degraded dryer allowing appropriate action to be taken to minimize the damage to the dryer and the potential for loose parts generation.
- o Monitoring the trends in parameter values may be more important than monitoring the parameter values against absolute action thresholds. An unexplained change in the trend or value of a parameter, particularly steam moisture content or the flow distribution between individual steamlines may be an indication of a breach in the dryer hood, even though the absolute value of the parameter is still within the normal experience range.
- o Statistical smoothing techniques such as calculating running averages using a large quantity of samples may be necessary to eliminate the process noise and allow the changes in the trend to be identified.
- o An experience base should be developed for each plant that correlates the changes in monitored parameters to changes in plant operation (rod patterns, core flow, etc.) in order to be able to distinguish the indications of a degraded dryer from normal variations that occur during the operating cycle.

Recommended Actions:

GE Nuclear Energy recommends that owners of GE BWRs consider the following:

A. For all plants:

A1. Perform a baseline visual inspection of all susceptible locations of the steam dryer within the next two scheduled refueling outages. Inspection guidelines showing the susceptible locations for each dryer type are provided in Appendix C.

- a. Repeat the visual inspection of all susceptible locations of the steam dryer at least once every two refueling outages.
- b. For BWR/3-style steam dryers with internal braces in the outer hood that are operating above OLTP, repeat the visual inspection of all susceptible locations of the steam dryer during every refueling outage.
- c. Flaws left “as-is” should be inspected during each scheduled refueling outage until it has been demonstrated that there is no further crack growth and the flaws have stabilized.

Note: This recommendation does not supercede the inspection schedules for existing flaws for which plant-specific evaluations already exist.

- d. Modifications and repairs to cracked components should be inspected during each scheduled refueling outage until the structural integrity of the modifications and repairs has been demonstrated. Once structural integrity of any modifications and repairs has been demonstrated, longer inspection intervals for these locations may be justified.

Note: This recommendation does not supercede the inspection schedules for existing modifications or repairs for which plant-specific evaluations already exist.

- A2. Implement a plant parameter monitoring program that measures moisture content and other plant parameters that may be influenced by steam dryer integrity. Initial monitoring should be performed at least weekly. Monitoring guidelines are provided in Appendix D.
- A3. Review drawings of the steam dryer to determine if the lower cover plates are less than 3/8 inch thick or if the attachment welds are undersized (less than the lower cover plate thickness). If this is the case, and the plant has operated above OLTP, review available visual inspection records to determine if there are any pre-existing flaws in the cover plate and/or the attachment welds.
- B. In addition, for plants planning on increasing the operating power level above the OLTP or above the current established uprated power level (i.e., the plant has operated at the current power level for several cycles with no indication of steam dryer integrity issues), the recommendations presented in A (above) should be modified as follows:
 - B1. Perform a baseline visual inspection of the steam dryer at the outage prior to initial operation above the OLTP or current power level. Inspection guidelines for each dryer type are provided in Appendix C.
 - B2. Repeat the visual inspection of all susceptible locations of the steam dryer during each subsequent refueling outage. Continue the inspections at each refueling outage until at least two full operating cycles at the final uprated power level have been achieved. After two full operating cycles at the final uprated power level, repeat the visual inspection of all susceptible locations of the steam dryer at least once every two refueling outages. For BWR/3-style steam dryers with internal braces in the outer hood, repeat the visual inspection of all susceptible locations of the steam dryer during every refueling outage.
 - B3. Once structural integrity of any repairs and modifications has been demonstrated and any flaws left “as-is” have been shown to have stabilized at the final uprated power level, longer inspection intervals for these locations may be justified.

To receive additional information on this subject or for assistance in implementing a recommendation, please contact your local GE Nuclear Energy Representative.

This SIL pertains only to GE BWRs. The conditions under which GE Nuclear Energy issues SILs are stated in SIL No. 001 Revision 6, the provisions of which are incorporated into this SIL by reference.

Product reference

- B11 — Reactor Assembly
- B13 — Reactor System

Issued by

Bernadette Onda Bohn, Program Manager
Service Information Communications
GE Nuclear Energy
3901 Castle Hayne Road
M/C L10
Wilmington, NC 28401

Appendix A

2002 BWR/3 Event

On June 7, 2002, while operating at approximately 113% of OLTP, the BWR/3 experienced a mismatch between the “A” and “B” reactor vessel level indication channels, a loss of approximately 12 MWt, and a reactor pressure decrease. Following the event, measurement indicated that the moisture content had increased by a factor of 10 (to a value of 0.27%). The reactor pressure decrease, reactor vessel level indication mismatch, and increase in moisture content comprised a set of concurrent indications suggesting a possible failure of the steam dryer. It was evaluated that there were no safety concerns associated with the observed conditions, and the plant continued to operate after implementing several compensatory measures (e.g., reactor water level setpoint adjustments, increased frequency of moisture content measurements).

Following the initial event, additional short duration (several minutes to ½ hour) perturbations occurred and the moisture content continued to increase. When the moisture content increased to approximately 0.7%, the power level was reduced to approximately 97% of OLTP. At this reduced power, the frequency of the plant perturbations decreased, along with the moisture content. Given the stable plant response at this lower power, the power was increased to 100% OLTP approximately one week later.

On June 30, subsequent to the power reduction to the OLTP level, a step change increase in the reactor steam dome pressure was noted. No changes in turbine control valve positions or pressure in the turbine steam chest were observed. Several additional perturbations occurred over the following week with the reactor steam dome pressure continuing to increase (to a total of 15 to 20 psi above normal conditions) along with a divergence of the measured total main steam line (MSL) flows compared to the total feedwater flow. The plant was shut down on July 12 to inspect the steam dryer.

Inspection Results:

Inspection of the steam dryer revealed that a ¼-inch stainless steel cover plate measuring approximately 120” x 15” had failed near the MSL “A” and “B” nozzles (Figure A-1). The failure of this cover plate allowed steam to bypass the dryer banks and exit through the reactor MSL nozzles, causing the observed increase in moisture content. The majority of the cover plate was found as a single piece on top of steam separators. However, a piece of the cover plate (approximately 16”x 6”) had failed and was found lodged in and partially blocking the MSL “A” flow venturi contributing to the MSL flow imbalance and water level perturbations. Several smaller loose pieces (believed to have come from a startup pressure sensor bracket which may have been knocked off by the cover plate) were located at the turbine stop valve strainer basket. Minor gouges and scratches from the transport of foreign material were noted in the “A” steam nozzle cladding, the main steam piping and the MSL “A” flow venturi. All loose pieces were recovered. No collateral damage to other reactor vessel components was observed.

The cover plate was welded in place as part of the original equipment dryer assembly. No known prior repairs had been made to the cover plate. The cover plate is not connected or adjacent to the dryer modification performed at the previous outage; all flow distribution plates installed as part of the dryer modification were intact in the as-installed condition.

Metallurgical Evaluation:

Preliminary laboratory analysis has been completed. The main crack originated from the bottom side of the cover plate and propagated upward through both the plate base metal and weld metal. The transgranular, as opposed to intergranular, nature of the fracture surface and the relative lack of crack branching indicated that the failure was not caused by stress-corrosion cracking. The lack of macro and micro ductility features in and near the fracture indicated the cracking occurred over a period of time and not due to a mechanical overload. Additionally, there was no evidence that the failure was a result of an original manufacturing defect. Based on the available evidence, the most probable cause of the cover plate cracking was mechanical, high cycle fatigue.

Root Causes:

The results of the metallurgical analysis confirmed that the failure mechanism is high cycle fatigue. The cause of this high cycle fatigue is believed to be flow induced vibration. At this time there are two probable root causes of the cover plate failure:

1. Increased pressure oscillations on the steam dryer due to the increased steam flows at extended power uprate conditions, aggravated by the potential presence of a pre-existing crack in the cover plate.
2. A flow regime instability that results in localized, high cycle pressure loadings near the MSL nozzles. When the natural frequency of the installed cover plate coincides or nearly coincides with the frequency of the cyclic pressure forcing function, and the acoustic natural frequency of the steam zone, the resulting resonance or resonances can lead to high vibratory stresses and eventual high cycle fatigue failure of the cover plate.

Corrective Actions:

The cover plates on both sides of the dryer have been replaced with ½-inch continuous plates (this eliminates two intermediate welds on the original plates). The fillet weld connecting the plate to the support ring was increased to ¾-inch and the weld to the vertical face of the dryer hood was increased to ½-inch. The plant has been returned to service with interim, enhanced monitoring of moisture content, reactor steam dome pressure, MSL flow rates and reactor water level. As an additional measure, the plant has implemented dynamic response monitoring of the MSLs to determine if higher flow induced vibration occurs as the steam flow is increased.

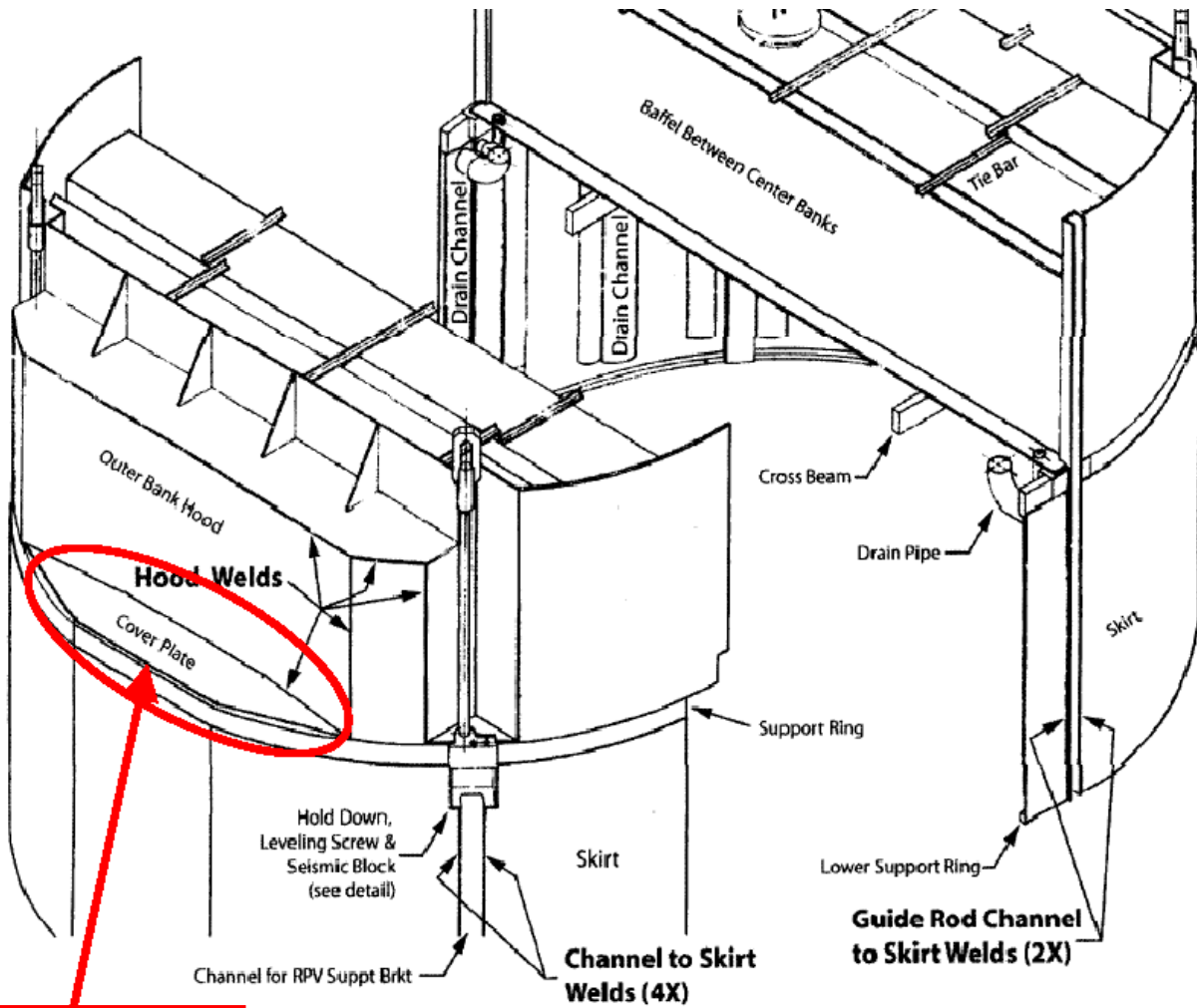

Missing Cover Plate

Figure A-1: Location of the 2002 Lower Cover Plate Failure

Appendix B

2003 BWR/3 Event

On April 16, 2003, with the plant operating at extended power uprate (EPU) conditions, an inadvertent opening of a pilot operated relief valve (PORV) occurred. The unit was shut down and the PORV replaced. On May 2, 2003, following return to EPU conditions, a greater than four-fold increase in the moisture content was measured. The moisture content continued to gradually increase until it exceeded a pre-determined threshold of 0.35% on May 28, 2003. The power level was reduced to pre-EPU conditions that resulted in a moisture content reduction to 0.2%. The moisture content remained steady at this value following the power reduction with no significant changes in other reactor operating parameters observed by the operators.

A detailed statistical evaluation of key plant parameters concluded that a subtle change in the MSL flows had occurred following the April 16, 2003 PORV event. Based on this information, concurrent with the moisture content increase, the utility elected to shut down the unit on June 10, 2003 and perform a steam dryer inspection.

Inspection results

A detailed visual inspection of the accessible external and internal areas of the steam dryer revealed significant steam dryer damage. The damage was most severe on the 90-degree side of the steam dryer, the side that was closest to the PORV that had opened. On the 90-degree side, a through-wall crack approximately 90 inches long and up to three inches wide was observed in the top of the outer hood cover plate and the top of the vertical hood plate (refer to Figures B-1 and B-2). Three internal braces in the outer hood were detached and one internal brace in the outer hood was severed. The detached braces were found on top of the steam separator. All detached parts were accounted for and retrieved. On the opposite side of the steam dryer (270-degree side), incipient cracking was observed on the inside of the outer hood cover plate and one vertical brace in the outer hood was cracked. No damage was found in the cover plates that had been replaced following the first steam dryer failure in 2002.

Three tie bars on top of the steam dryer connecting the steam dryer banks were also cracked. Tie bar cracking has been observed on several other steam dryers (including plants that have not implemented EPU); therefore, tie bar cracking is believed to be unrelated to the other damage noted above.

Root cause of steam dryer failure

Extensive metallurgical and analytical evaluations (e.g., detailed finite element analyses, flow induced vibration analyses, computational fluids dynamics analyses, 1/16th scale model testing and acoustic circuit analyses) concluded that the root cause of the steam dryer failure was high cycle fatigue resulting from low frequency pressure loading. There are two potential contributing factors to the failure:

1. Continued operation for approximately 1 month following the failed cover plate in 2002 which resulted in additional stress loading on the vertical hood plate, and
2. Inadvertent opening of the PORV resulting in a decompression wave, which subjected the steam dryer to two to three times the normal pressure loading. (It is believed that there was incipient cracking in the steam dryer and the PORV event caused the cracks to open up).

The root cause identified in the first steam dryer failure was high cycle fatigue cause by high frequency pressure loading. The low frequency pressure loading was identified as the dominant cause

in this failure. The low frequency pressure loading may have also been a significant contributing factor in the first failure.

Corrective Actions:

The following repairs and pre-emptive modifications were made to both the 90 and 270-degree sides of the steam dryer:

1. replaced damaged ½ inch outer hood plates with 1 inch plates
2. removed the internal brackets that attached the internal braces to the outer hood
3. added gussets at the outer vertical hood plate and cover plate junction
4. added stiffeners to the vertical welds and horizontal welds on the outer hood

The combined effect of these modifications was to increase the natural frequency of the outer hood, reduce the maximum stress by at least a factor of two, and reduce the pressure loading by reducing the magnitude of vortices in the steam flow near the MSLs.

Following the steam dryer modifications, the unit was returned to service on June 29, 2003.

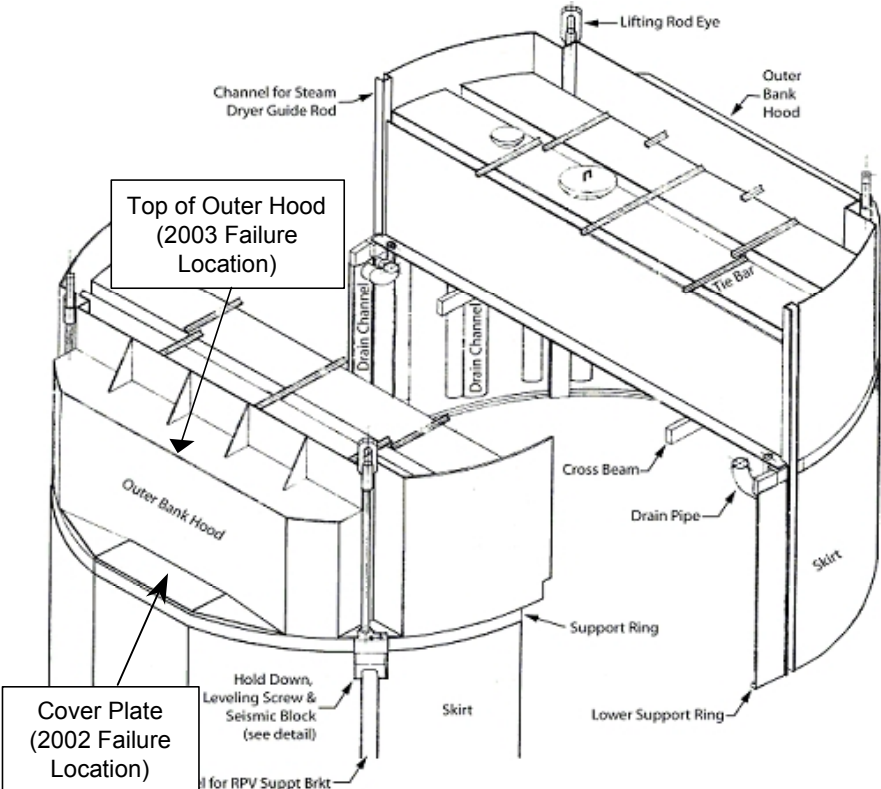

Figure B-1: Location of the 2003 Outer Hood Failure

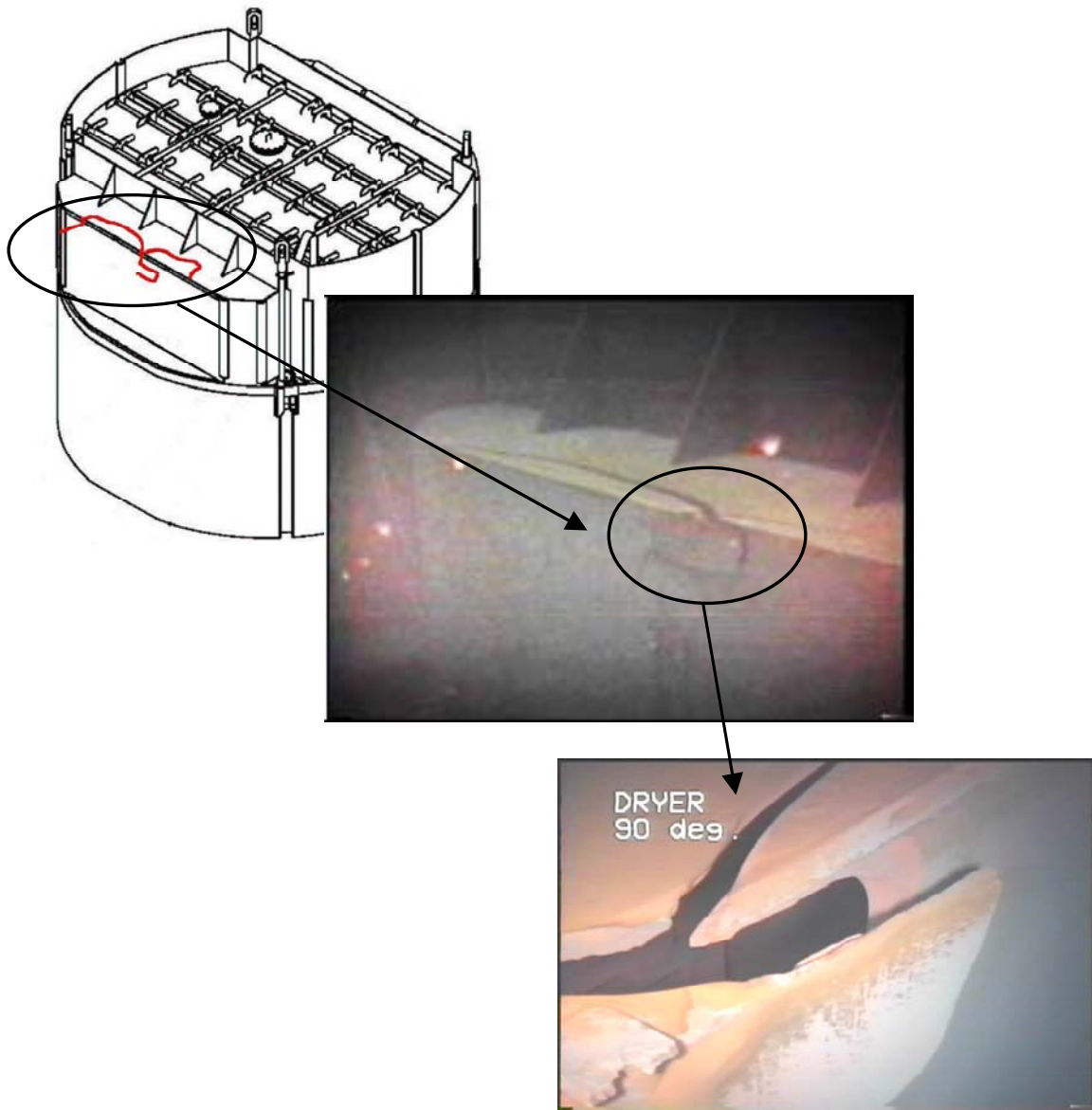

Figure B-2: Steam Dryer Damage 90 Degree Side

Appendix C

Inspection Guidelines

Overview

The steam dryers have been divided into four broad types with fourteen sub-groups: BWR/2 design, square hood design, slanted hood design and the curved hood design. The focus of the inspections for each dryer type is divided into two categories. The first category is directed at the outer surfaces of the dryer that are subject to fluctuating pressure loads during normal operation and are potentially susceptible to fatigue cracking. The second category is directed at the cracking that has been found in the drain channels and in inner bank end plates. These latter locations are not associated with any near term risk of loose part generation. They have often been associated with IGSCC cracking in the heat-affected-zones of stainless steel welds.

Inspection Techniques

Based on the current experience in inspecting the dryer components, VT-1 is the recommended technique to be employed for the inspections. VT-1 resolution, distance, and angle of view requirements should be maintained to the extent practical. In instances where component geometry or remote visual examination equipment limitations preclude the ability to maintain the VT-1 requirements over the entire length of the different weld seams, "best effort" examinations should be performed. In that cracking will be expected to have measurable length (several inches), field experience has confirmed that "best effort" approaches are sufficient to find the cracking that is present.

Steam Dryer Integrity Inspection Recommendations

The recommendations are divided into three categories: BWR/2 and square hood taken together, slanted hood and curved hood steam dryers. The inspection recommendations for each type of dryer will be detailed using schematics of the outer dryer structure. The key weld seams that must be inspected are outlined in red or green. High stress locations associated with structural integrity are outlined in red. Locations associated with field dryer cracking experience are outlined in green. Typical horizontal and vertical welds are shown thereby providing guidance for establishing a plant specific inspection plan. The weld numbering approach shown in the figures is only given as an example. Due to the many welds and size differences, each plant should employ their own weld numbering system. If an indication is detected, care should be exercised when inspecting the symmetrical locations on the dryer. If an indication is detected on the external surface of a plate or weld, consideration should be given to inspecting the location from the inside of the dryer in order to determine if the indication is through-wall.

Square Hood Design: applicable to BWR/2 plants and BWR/3 plants

Several square hood dryers were built with interior brackets and diagonal braces. These structures produce stress concentration locations, which have been found to aid in the initiation of fatigue cracking. These brackets exist in both the outer and the inner dryer banks. The recommended inspections follow.

Steam Dryer Bank Inspections

Figure C-1 provides the overview of the square dryer design. These dryers will require both an external and internal inspection. All dryers are symmetrical from this perspective. Outlined in red

are the key weld seams that must be inspected. These welds, both horizontal and vertical outline the outer dryer bank. These locations considered as high stress locations. Figure C-2 displays a cross-section of the BWR/2 steam dryer with the outer bank peripheral welds highlighted. This configuration has no lower cover plate. However, the external locations that match those shown in Figure C-1 need to be inspected in a similar fashion to the other square hood dryers. Figures C-3 and C-4 provide the details of the weld seams as viewed from the dryer bank interior. As shown in Figure C-3, the outer bank welds need to be inspected from both the dryer exterior and the dryer interior. In addition, for the dryers where there are interior brackets that were present in the original design and are still present, the interior inspection must be conducted of the weld region where the bracket is joined to the hood vertical and top plates. Figure C-3 shows these locations for the outer banks hoods. Figure C-4 shows the brackets for the inner hood. In addition, Figure C-5 provides a cross section of the bracket-diagonal brace substructure. The intersection locations between the bracket and the top and outer hood are also outlined in red in these figures. In that the concern is primarily fatigue cracking, several inches of base material adjacent to welds should be examined as well as any obvious discontinuity, e.g., the exterior base material should be examined in the general area where there is an internal weld. This inspection examination region includes the heat-affected-zone and will therefore detect any IGSCC cracking. This figure also shows locations in green that exhibited cracking in the field. The region of inspection should be the same.

Tie Bar Inspections

In addition to the outer bank and interior bracket locations, tie bars also require inspection. Figure C-6 provides a schematic of the tie bars. These are located between each set of dryer banks.

Inspections Based on Field Experience

The other locations of interest are primarily associated with IGSCC in drain channels (shown for information in Figures C-7 and C-8). These components will be part of the internal examination. While these indications have been historically associated with BWR/4 through BWR/6 plants (SIL No. 474 “Steam Dryer Drain Channel Cracking” issued October 26, 1988), recent findings indicate that cracking can occur in these locations in square hood dryers. The additional weld seams associated with the outer side of the next set of inner banks should also be inspected in that this represents a steam path through the dryer. These areas are shown in green in Figure C-1. Cracking has been detected in these end panels in later design dryers. Finally, cracking at the steam dams as indicated in green in Figure C-6 has occurred in one BWR/4. These locations need to be included in the inspection plan for all of these plants. Finally, bank inner surface welds have cracked in the BWR/2. These locations, shown in Figure C-2 in green, also need to be inspected.

Slanted Hood Design: applicable to BWR/4 plants

The slanted hood steam dryers fall into three categories for which the primary difference is diameter and the number of banks. These dryers use 2 or 3 stiffener plates to strengthen each dryer bank. All inspections are on the external surface of the dryer. However, if an indication is detected on the external surface of a plate or weld, consideration should be given to inspecting the location from the inside of the dryer in order to determine if the indication is through-wall. The recommended inspections follow.

Steam Dryer Bank Inspections

Figure C-9 provides the overview of the slanted dryer design. All dryers are symmetrical from this perspective. Outlined in red are the key weld seams that must be inspected from the external surface. These welds, both horizontal and vertical outline the outer dryer bank as well as the cover plate

between the outer hood vertical plate and the support ring. Additional red lines represent the outside projected location where the stiffener plates are welded to the outer hood vertical plate. These locations are considered as high stress locations. The man-way welds (on one side) are also shown as locations requiring inspection.

Tie Bar Inspections

In addition to the outer bank and interior bracket locations, tie bars also require inspection. Figure C-10 provides a schematic of the tie bar locations joining the tops of each set of banks. The primary concern is the presence of fatigue cracking through the bar base material cross-section at axial location where the tie bar is attached to the bank.

Inspections Based on Field Experience

Cracking has been detected in these end panels in later design dryers. Therefore, these additional weld seams associated with the outer side of the inner banks should also be inspected in that this represents a steam path through the dryer. These areas are shown in green in Figure C-9. Cracking has been observed in these locations in dryers of this design. The other locations of interest are primarily associated with IGSCC in drain channels (refer to SIL No. 474 “Steam Dryer Drain Channel Cracking” issued October 26, 1988), support ring, and lifting rod attachments.

Curved Hood Design: applicable to BWR/4-BWR/6 and ABWR plants

The curved hood steam dryers fall into five categories for which the primary differences are diameter and inner bank hood thickness. Similar to the slanted hood dryers, these dryers also have 2 or 3 interior stiffener plates to strengthen each dryer bank. All inspections are on the external surface of the dryer. However, if an indication is detected on the external surface of a plate or weld, consideration should be given to inspecting the location from the inside of the dryer in order to determine if the indication is through-wall. The recommended inspections follow.

Steam Dryer Bank Inspections

Figure C-11 provides the overview of the curved hood dryer design. All dryers are symmetrical from this perspective. Outlined in red are the key weld seams that must be inspected from the external surface. These welds, both horizontal and vertical outline the outer dryer bank as well as the cover plate between the outer hood vertical plate and the support ring. Additional red lines represent the outside projected location where the stiffener plates are welded to the outer hood vertical plate. Inspection locations also include outer plenum end plates and inner hood vertical weld seams for BWR/4 and BWR/5 plants with 1/8 inch thick hood plates on the inner banks. The location shown is the region where these thinner hood plates are attached to the stiffeners. All of these locations are considered as relative high stress locations. The man-way welds (on one side) are also shown as locations requiring inspection.

Tie Bar Inspections

In addition to the outer bank and interior bracket locations, tie bars also require inspection. Figure C-11 provides a schematic of the tie bar locations joining the tops of each set of banks. In that the attachment of the tie bars may have employed high heat input welds, the inspection should also include the entire welded region to assess the presence of IGSCC on the bank top plate. This region is adjacent to the region shown in red around the end of the inner bank tie bars.

Inspections Based on Field Experience

Cracking has been detected in the end panels in later design dryers. Therefore, these additional weld seams associated with the outer side of the inner banks should also be inspected in that this represents a steam path through the dryer. These areas are shown in green in Figure C-11. Cracking has been observed in these locations in dryers of this design. The other locations of interest are primarily associated with IGSCC in drain channels (refer to SIL No. 474 “Steam Dryer Drain Channel Cracking” issued October 26, 1988) and lifting rod attachments.

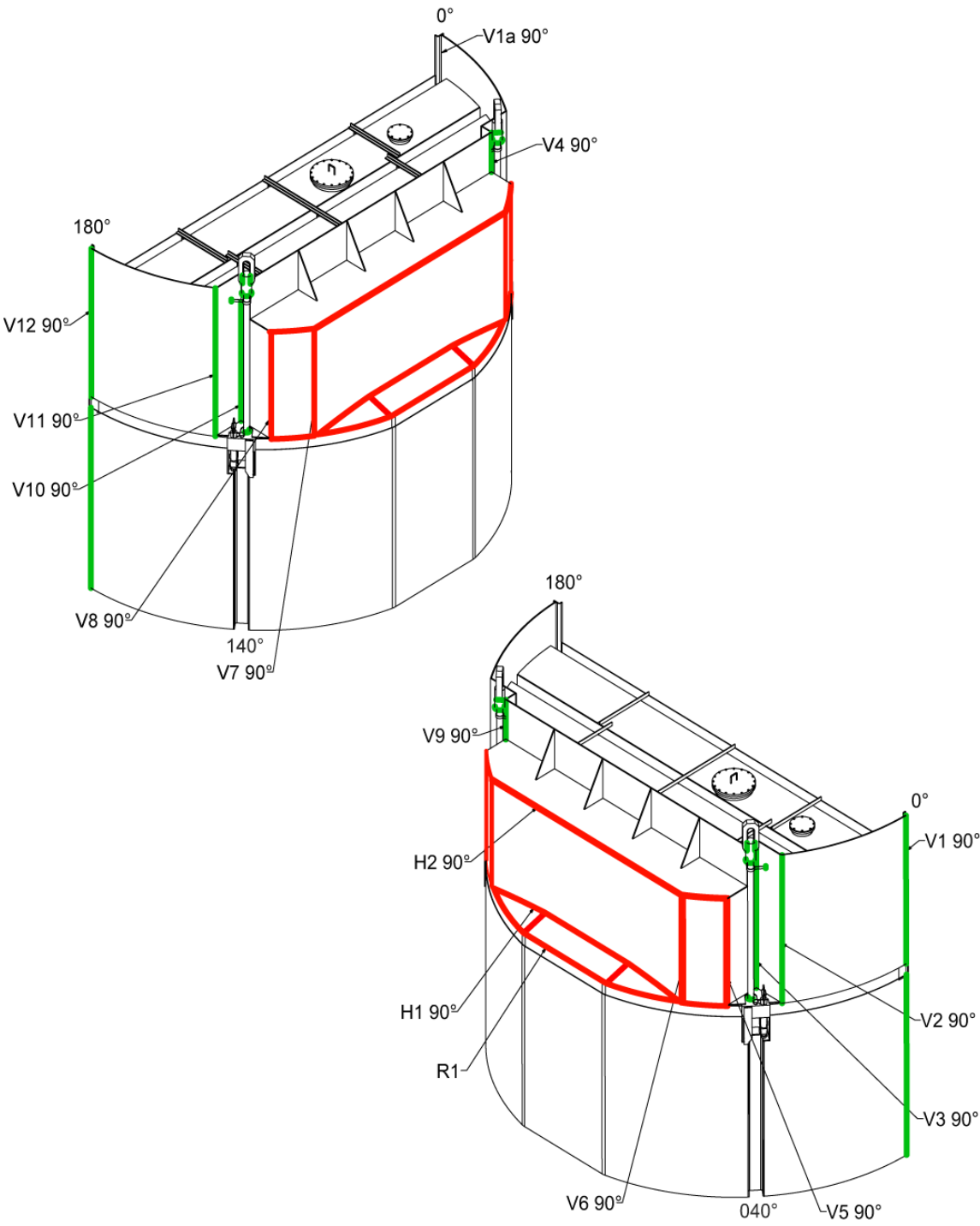

Figure C-1: Inspections: Outer Dryer Hood and Cover Plate (Square Hood Dryer)

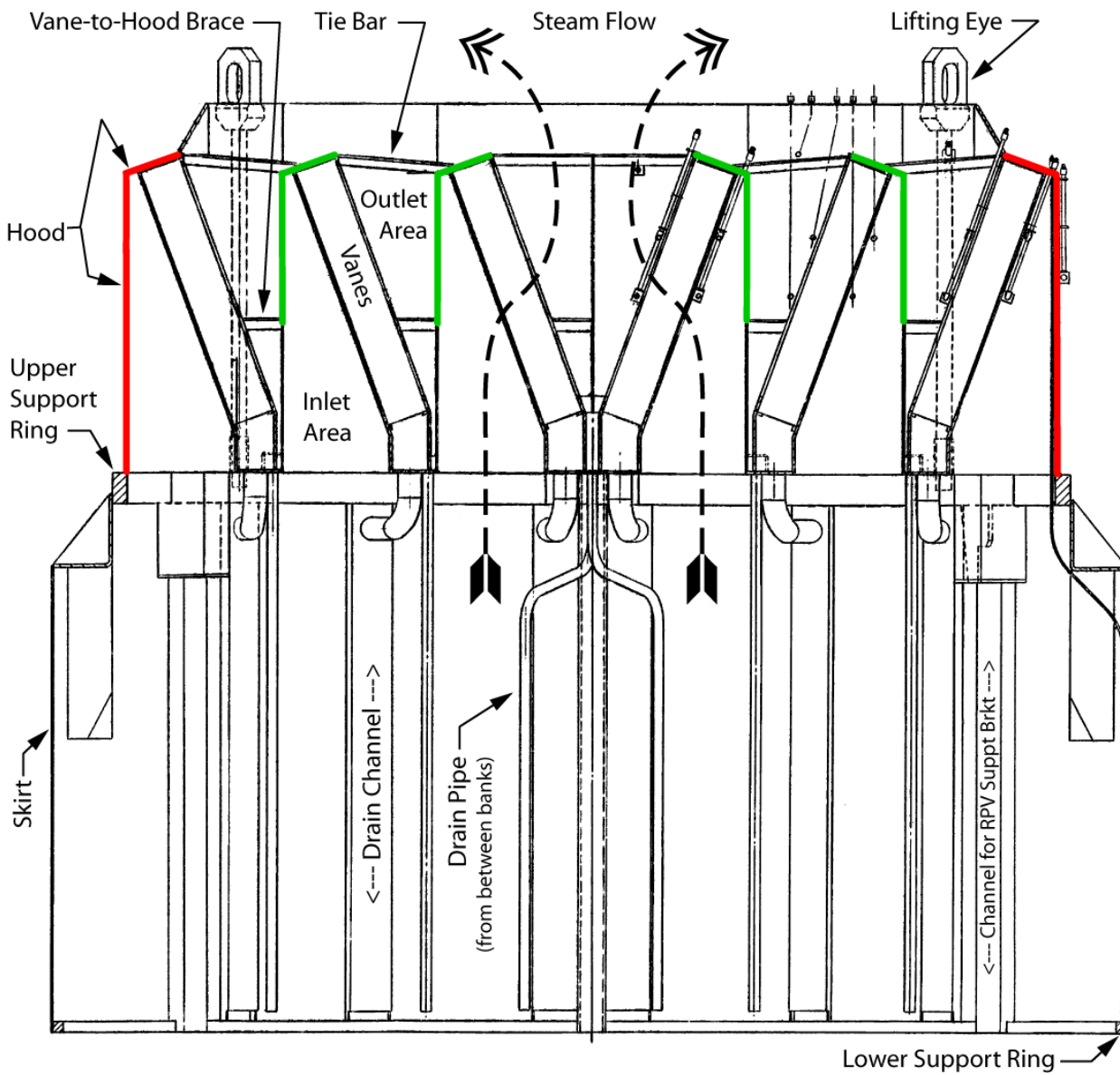

Figure C-2: Cross-Section of BWR/2 Steam Dryer

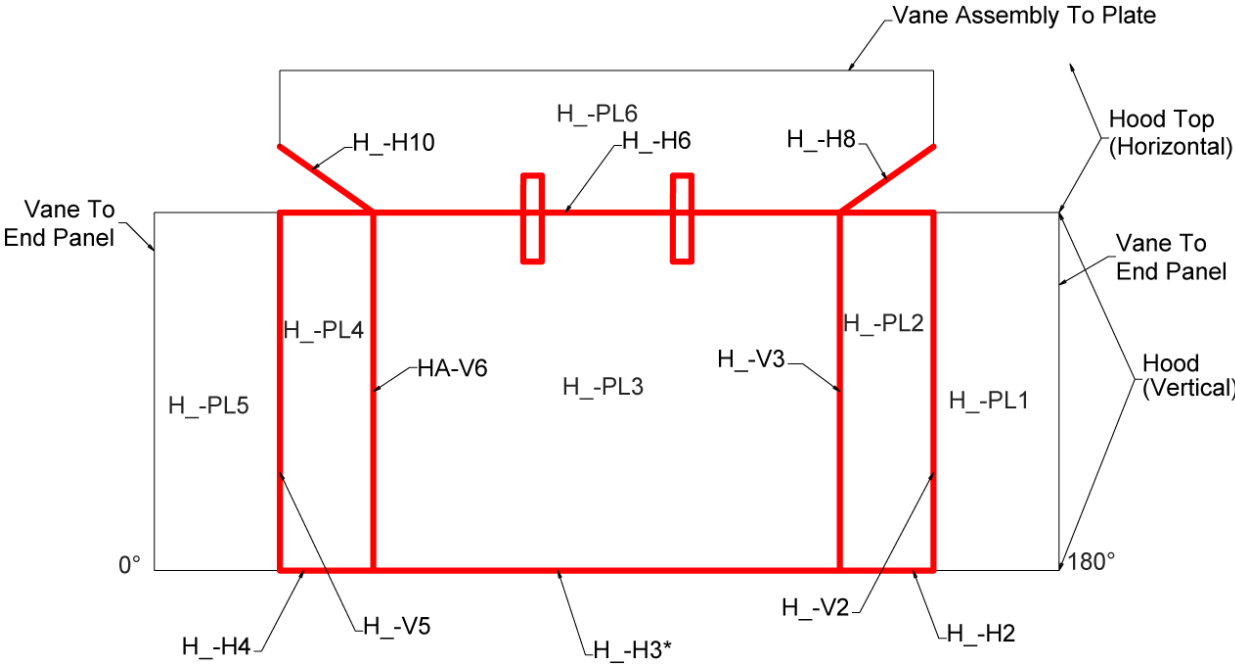
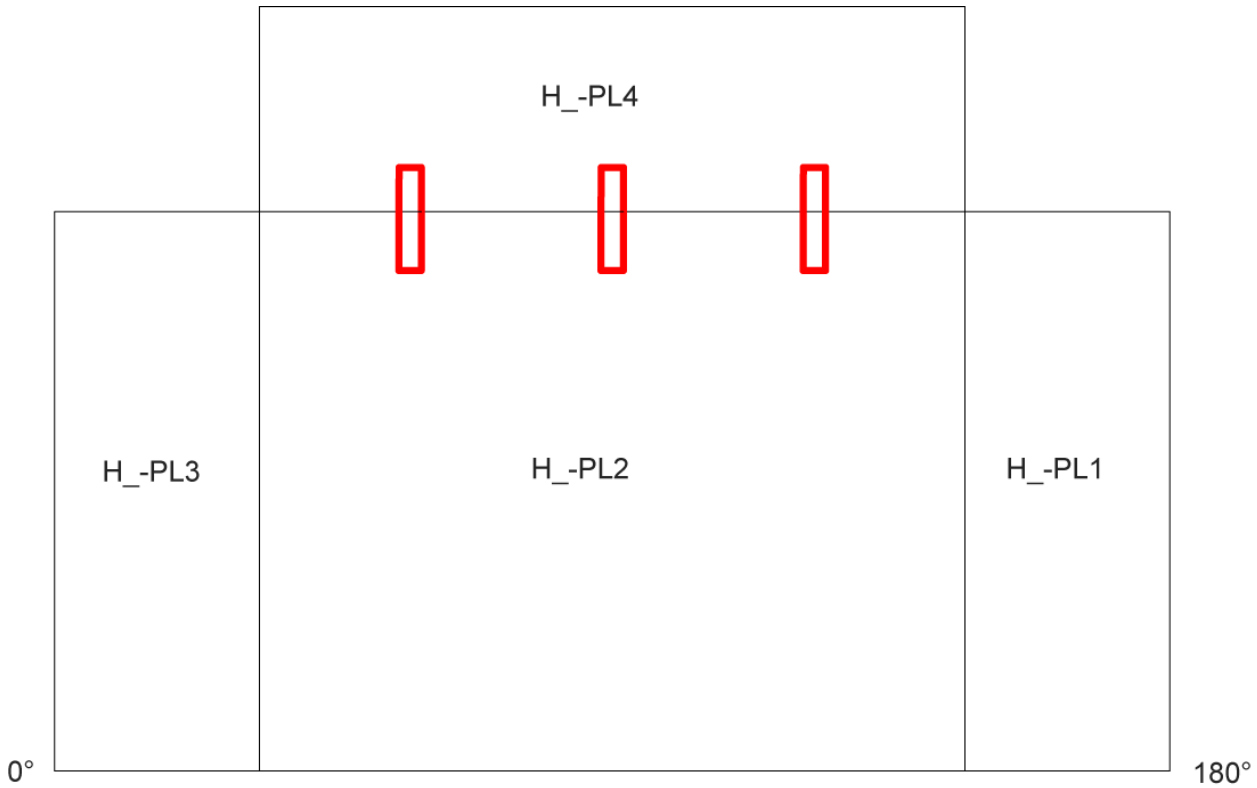

Figure C-3: Weld layout for interior of outer banks (Square Hood Dryer)

The brackets shown only exist in those plants where they were part of the original design and were not removed as part of dryer modifications.



H_-PL# = Plate (Bank B, C, D or E) (Ex. HB-PL1)
Internal View - View Is Looking Away From Vane Assembly

Figure C-4: Weld Rollout – Inner banks with internal brackets (Square Hood Dryer)

The brackets shown only exist in those plants where they were part of the original design and were not removed as part of dryer modifications.

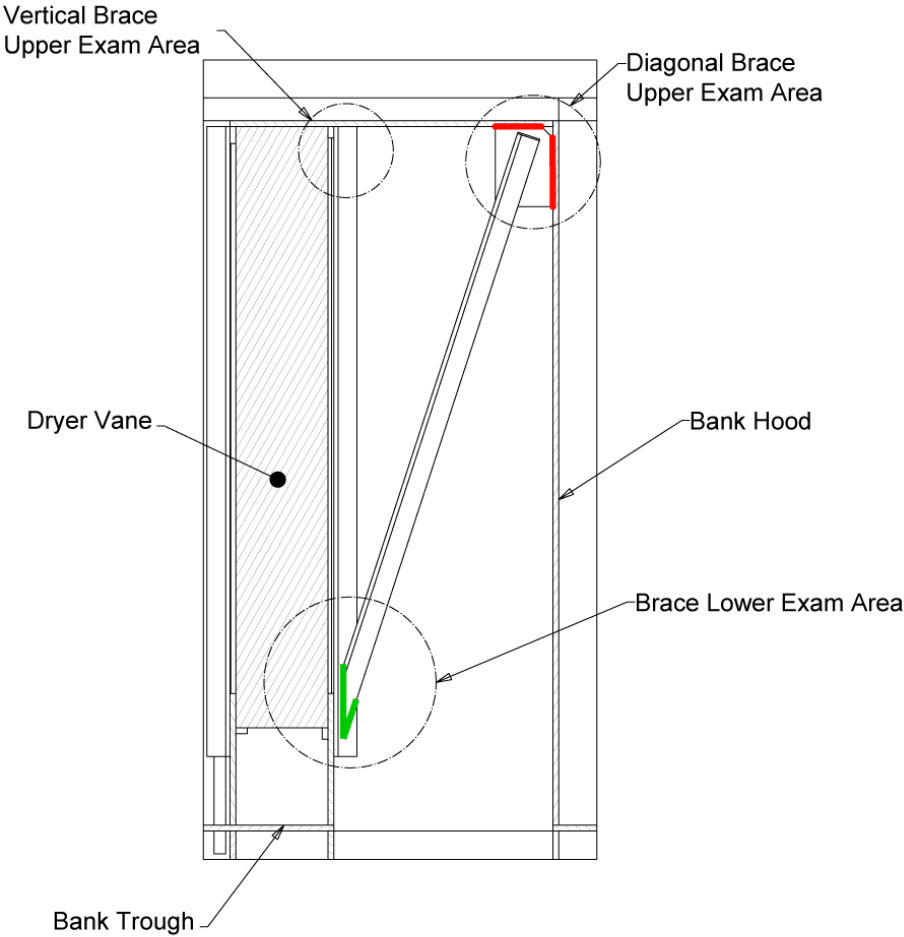

Figure C-5: Dryer Brace Detail (Square Hood Dryer)

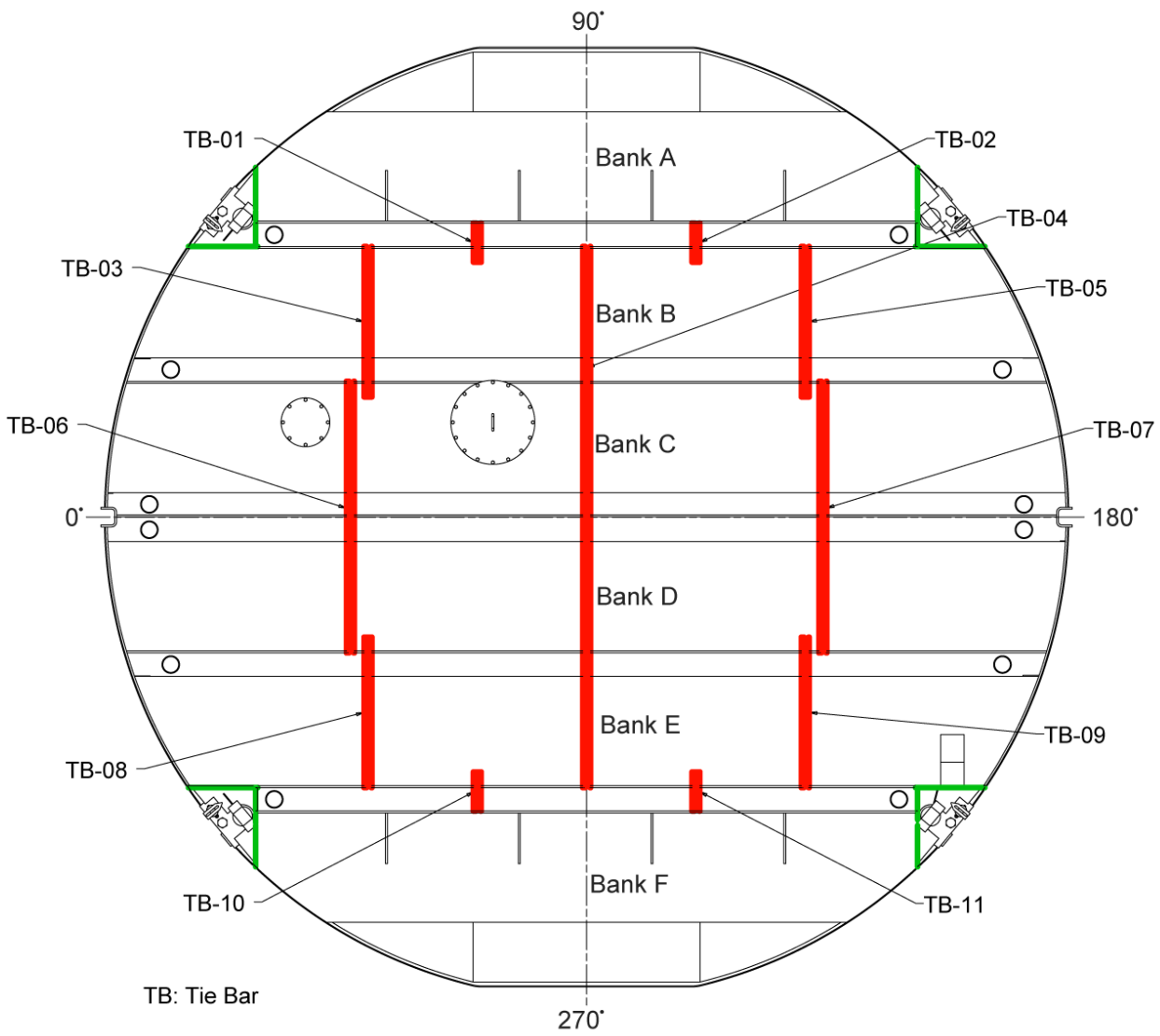

Figure C-6: Inspection Locations: Tie Bars and Steam Dam Inspections (Square Hood Dryer)

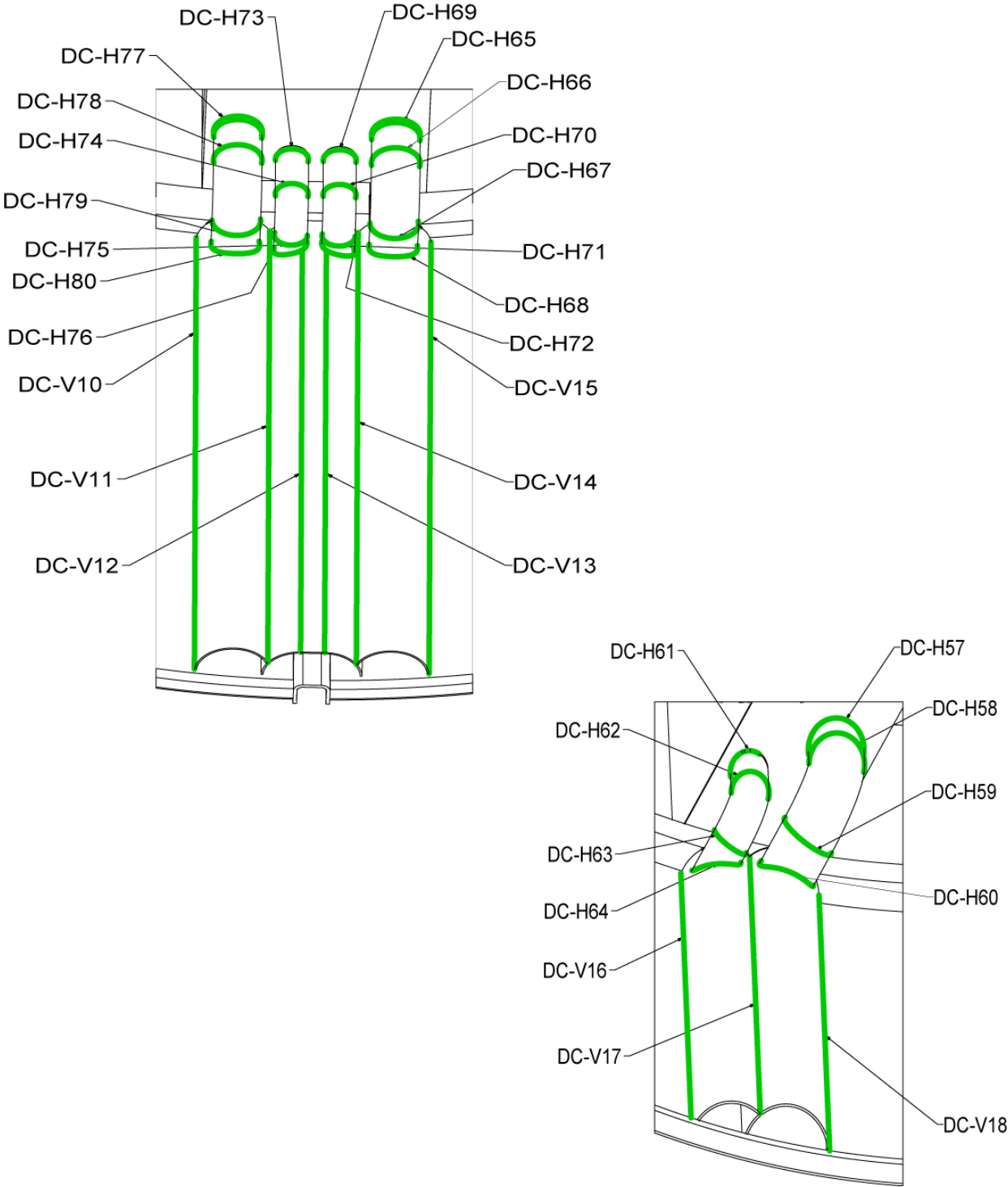

Figure C-7: Drain Channel Locations (Square Hood Dryer)

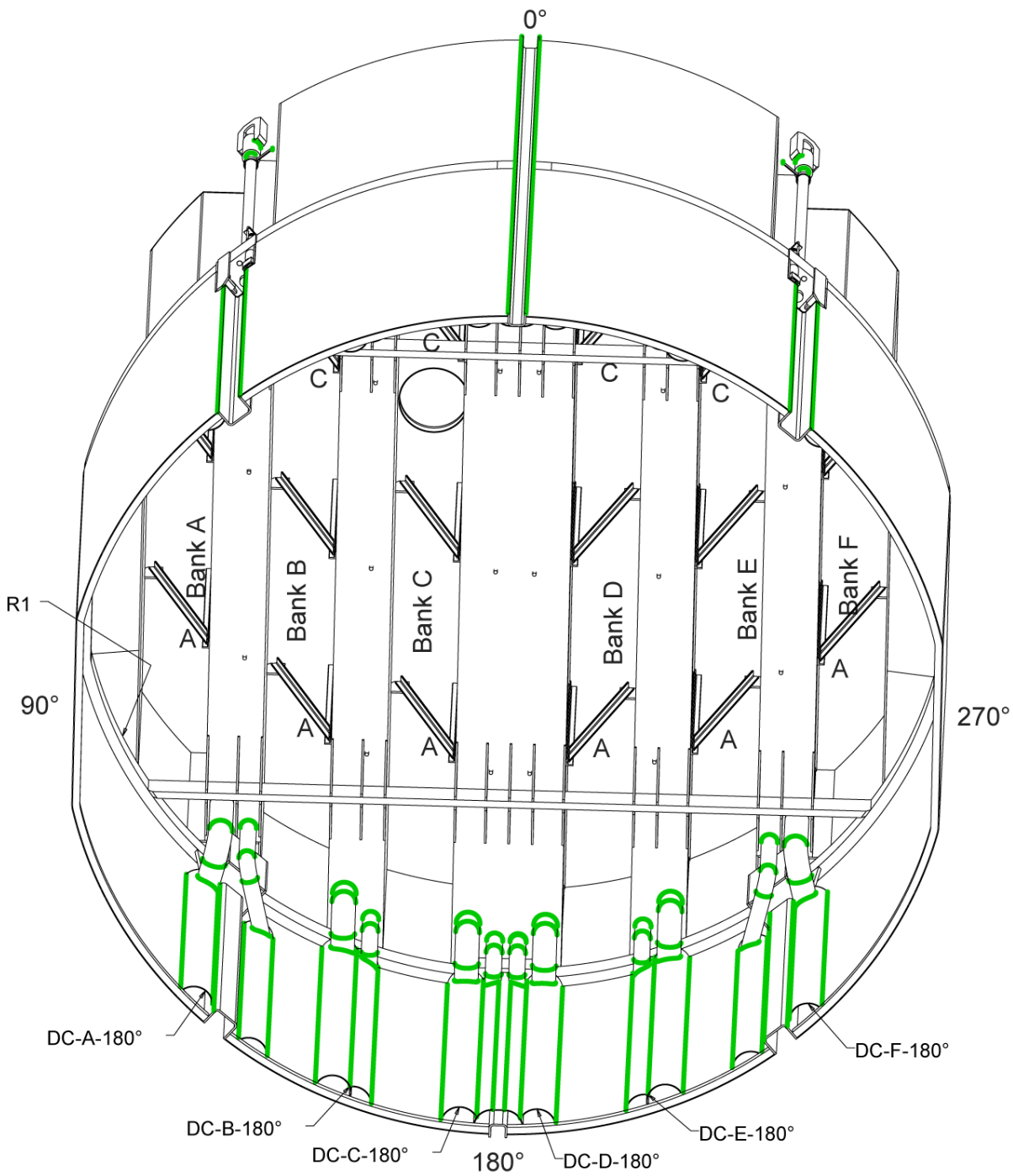

Figure C-8: Dryer Drain Channel, Guide channels and Guide Rod - Bottom View (Square Hood Dryer)

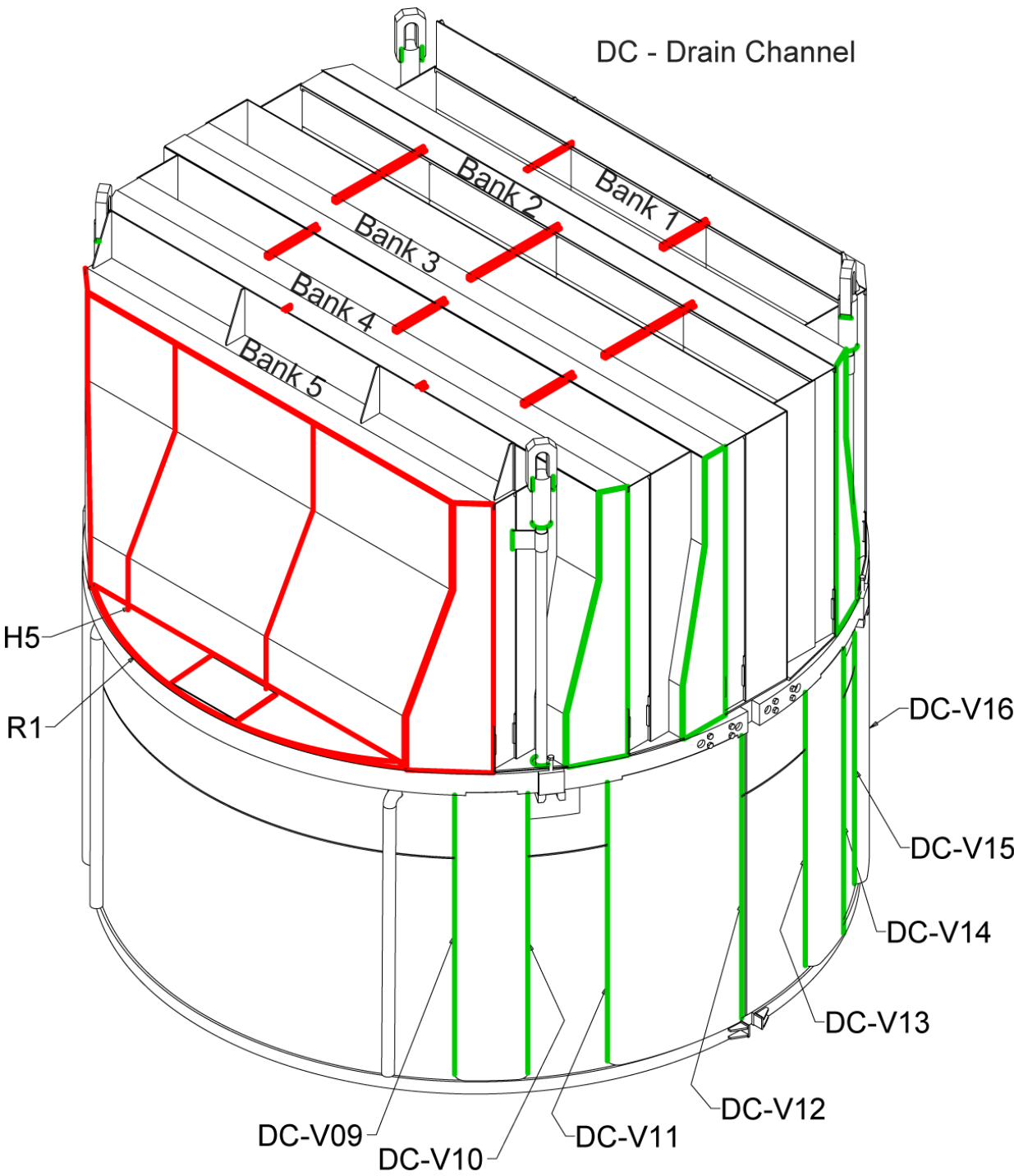

Figure C-9: Inspection Locations (Slanted Hood Dryer)

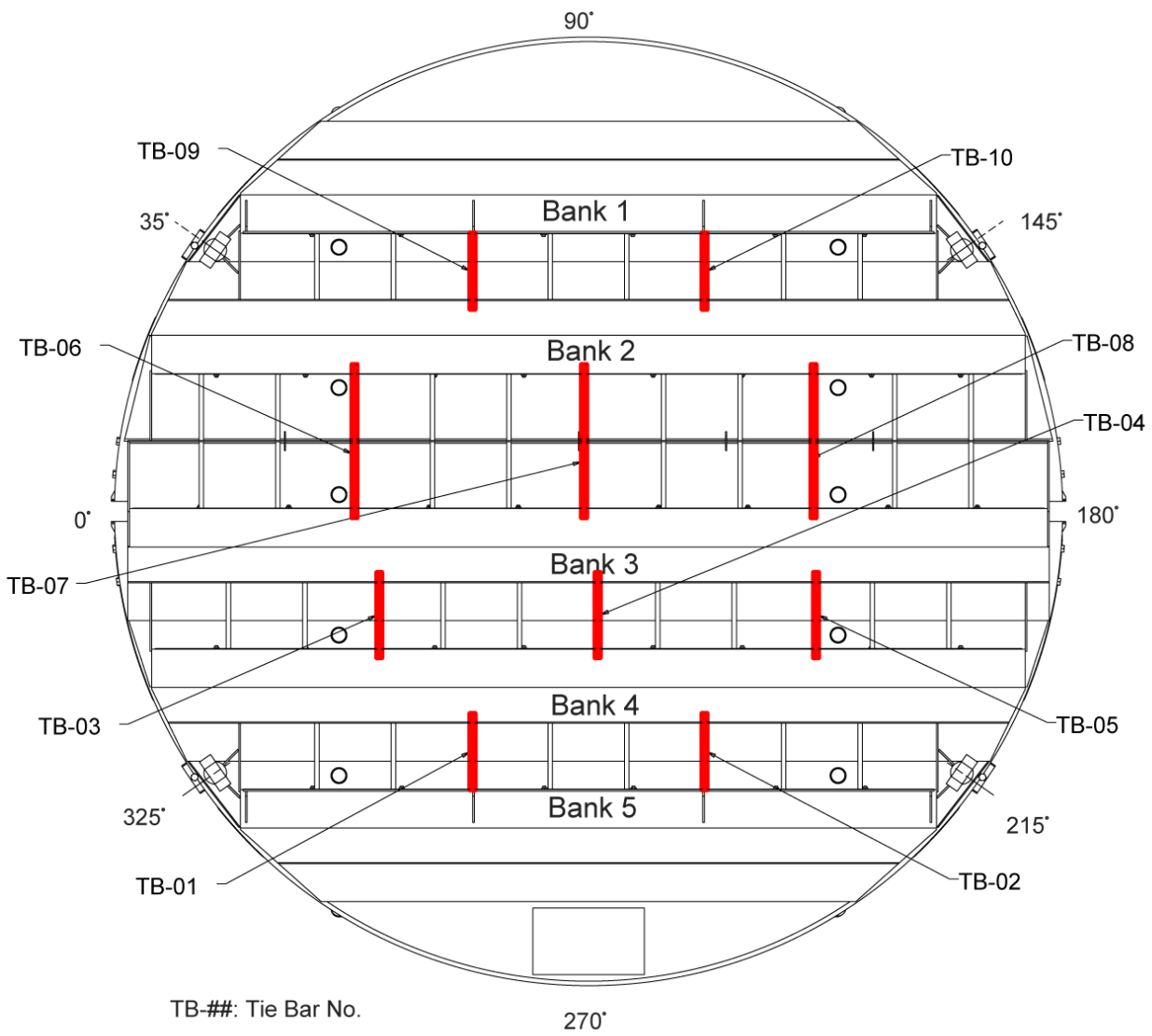

Figure C-10: Tie Bar Locations (Slanted Hood Dryers)

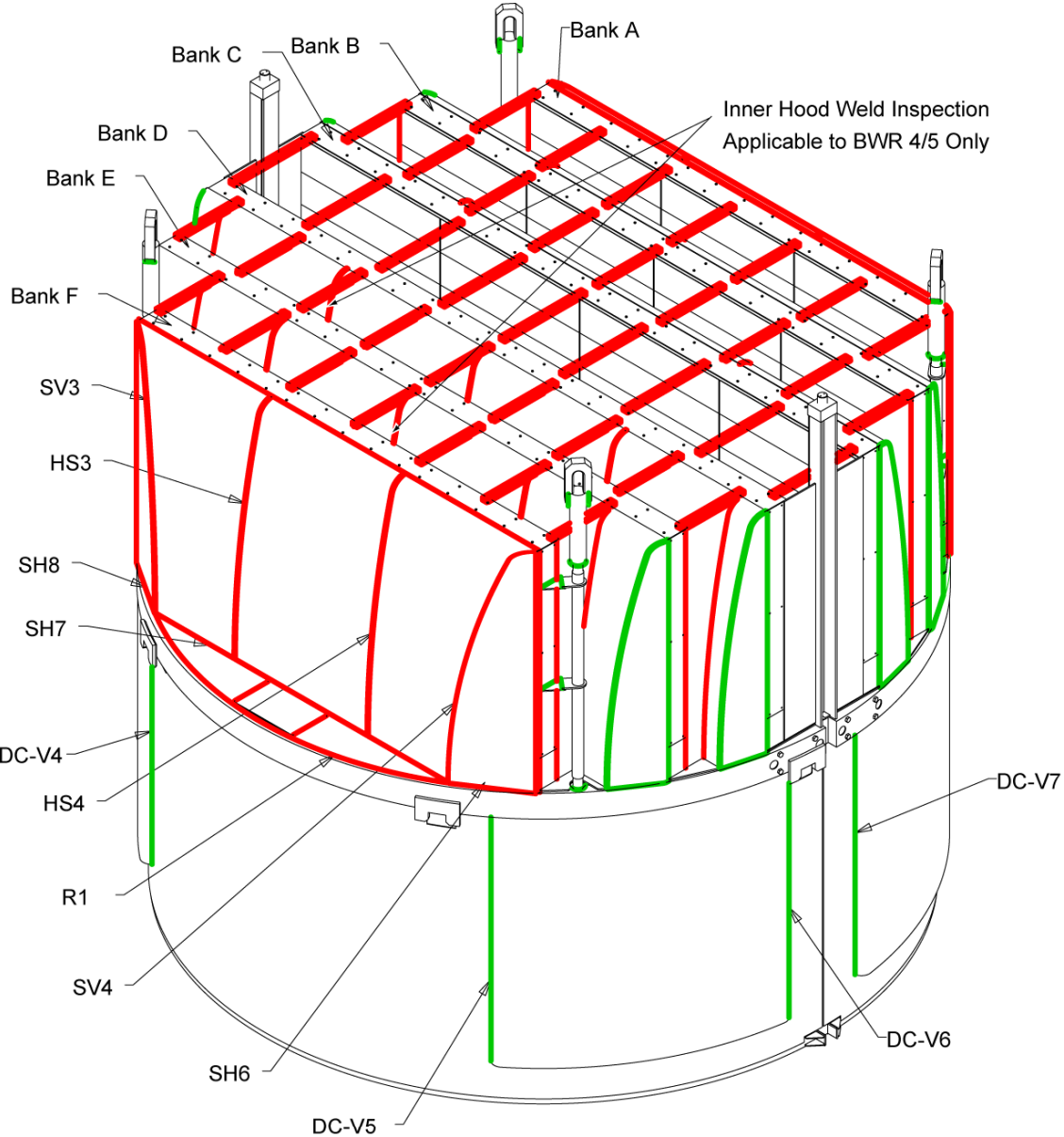

Figure C-11: Inspection Locations (Curved Hood Dryer)

Appendix D

Monitoring Guidelines

Applicability

In general, it is good practice to have access to as much performance data as practicable in order to make informed operational decisions. Therefore, GE recommends that all BWRs implement the moisture carryover and operational response guidance described here. However, plants that have sufficient baseline data and operating experience may elect to consider a less stringent monitoring program.

Background

A moisture carryover greater than 0.1% at the licensed power level is an indication of potential steam dryer damage, unless a higher threshold is established. A higher threshold may be warranted for a BWR with an unmodified square dryer hood (i.e., no addition of perforated plates) and/or operating with MELLLA+ at off-rated core flow.

If plants are reporting measured moisture carryover values of “less than” a value because of inability to measure Na-24 in the condensed steam sample and the “less than” value is greater than 0.025%, then the moisture carryover measurement process should be modified to reduce the minimum detectable threshold (preferably such that “less than” values are never reported). Without quantitative data, the plant staff will be unable to develop operational recommendations based on statistically valid moisture carryover and other plant data.

BWR moisture carryover may be impacted by: (1) reactor power level, (2) core flow and power distributions, (3) core inlet subcooling (which is related to final Feedwater temperature), and (4) reactor water level.

Moisture carryover is very sensitive to power level. Therefore, data should be collected during steady state operations at the highest possible power levels.

Moisture carryover has increased in cases where steam flow is increased towards the center of the core.

Moisture carryover has increased in cases where core inlet sub-cooling is decreased (i.e., final Feedwater temperature is increased).

Moisture carryover has increased in cases where reactor water level is increased (due to degraded separator performance).

Note that the standard deviation of moisture carryover measurements is not expected to change significantly following power distribution changes. However, if a significant condenser tube leak occurs, then the standard deviation of moisture carryover measurements may change significantly due to the resulting increased Na-24 concentrations.

Plants are recommended to accurately determine the flow distribution between individual steam lines. If significant steam dryer damage occurs, steam line flow distribution changes may result.

It may be helpful to have pressure data at each main steam flow element (venturi) to better understand the pressure drops and possible pressure changes due to moisture content changes in the steam line flow. This pressure data would have been beneficial at Quad Cities to help identify the flow blockage

upstream of the flow element following significant steam dryer damage. Note that flow element performance calculations are based on the RPV steam dome pressure.

An increased feed-to-steam mismatch (i.e., total Feedwater flow plus CRD flow minus total steam flow, with reactor water level constant) may validate an increase in moisture carryover. Plant application has confirmed this correlation exists when the initial moisture carryover value is low (~0.01%), however the correlation showed significant scatter at higher initial moisture carryover values (0.04% to 0.10%).

Baseline Data

NOTE

Data should be collected during steady state operations at the highest possible power levels.

Moisture Carryover

Measure moisture carryover daily to obtain at least five (5) measurements.

Statistically evaluate the moisture carryover data (e.g., determine the mean and standard deviation for the data) to determine if there is a significant increasing trend. Qualitatively review the data to ascertain if there is a significant increasing trend. If there is an increasing trend in moisture carryover, review the changes in plant operational parameters to determine if there is an operational basis for the trend.

If an unexplained increasing trend is evident, then collect additional moisture carryover data with consideration for increasing the measurement frequency (e.g., from “once per day” to “once per 12 hours”).

If an unexplained increasing trend is not evident, then begin collecting periodic data for moisture carryover.

Plant Operational Parameters

NOTE

Most plant operational data is available from the process computer, which can normally be input into an Excel spread sheet for evaluation and storage.

The following parameters should be measured under the same (or similar) plant conditions that existed during collection of moisture carryover baseline data:

Reactor power (MWt)

Core flow (Mlb/hr)

Core inlet sub-cooling (deg F)

Reactor water level, average of at least 1000 data points over a one to three hour time period.

Individual main steam line flows (Mlb/hr), average of at least 1000 data points over a one to three hour time period. Include pressure data at each MSL flow element (venturi), if available.

Total Feedwater flow (Mlb/hr), average of at least 1000 data points over a one to three hour time period.

CRD flow (Mlb/hr)

Periodic Data and Operational Response

NOTE

Data should be collected during steady state operations at the highest possible power levels.

If a moisture carryover measurement is suspect (e.g., less than “mean minus 2-sigma”), then repeat the moisture carryover measurement to verify sampling and analysis were performed correctly. Consider eliminating data shown to be incorrect/invalid.

Moisture carryover should be monitored weekly.

Statistically evaluate the moisture carryover data and qualitatively determine if there is a significant increasing trend that cannot be explained by changes in plant operational parameters.

If an unexplained increasing trend is evident, then collect additional moisture carryover data with consideration for increasing the measurement frequency (e.g., from “once per week” to “once per day”).

If the latest moisture carryover measurement is greater than “mean plus 2-sigma” and this increase cannot be explained by changes in plant operational parameters, then obtain a complete set of data for the plant operational parameters (identified above). Compare the current plant operational data with the baseline data to explain the increased moisture carryover (i.e., is there steam dryer damage or not).

If an increase in moisture carryover occurs immediately following a rod swap, additional moisture carryover data should be obtained to assure that an increasing trend does not exist. Note that occurrence of steam dryer damage immediately following a rod swap would be highly unlikely.

If the increasing trend of moisture carryover cannot be explained by evaluation of the plant operational data, then initiate plant-specific contingency plans for potential steam dryer damage.

If the evaluation of plant data confirms that significant steam dryer damage has most likely occurred, then initiate a plant shutdown.

If there are no statistically significant changes in moisture carryover for an operating cycle, then decreasing the moisture carryover measurement frequency (e.g., from “once per week” to “once per month”) may be considered, provided the highest operating power level is not significantly increased.