



Reactor-Physics Analysis Basis for Current CANDU

**Presentation to US NRC
2002 December**



**B. Rouben
Manager, Reactor Core Physics
AECL, Sheridan Park**

 **AECL**
TECHNOLOGIES INC.



Purpose

The objectives of this presentation are to:

- **discuss the basic design features of the current CANDU plant (some, but not all, of which are retained in the ACR design),**
- **present the computer programs used in reactor physics, and**
- **describe some of the more important modelling and analytical capabilities of the reactor-physics toolset.**



Basic Features of CANDU

Three basic features which have “defined” the CANDU design from the start:

- Heavy-water moderator
- Horizontal pressure-tube reactor (calandria is not pressurized)
- On-power refuelling



Consequences of Basic Features

Heavy-Water Moderator

- **Very high neutron economy and excellent fuel utilization**
- **Very high fuel-cycle flexibility**
- **Large lattice pitch: 28.6 cm in current CANDU.**
- **At this lattice pitch, spectrum is highly thermal: almost 99% of the neutrons in the cell are in the thermal group ($E < 0.625$ eV)**
- **Very long prompt-neutron lifetime: ~ 0.9 ms.**
- **Photoneutrons add $\sim 5\%$ to delayed-neutron fraction.**



Reactor Period vs. Reactivity for Various Prompt-Neutron Lifetimes

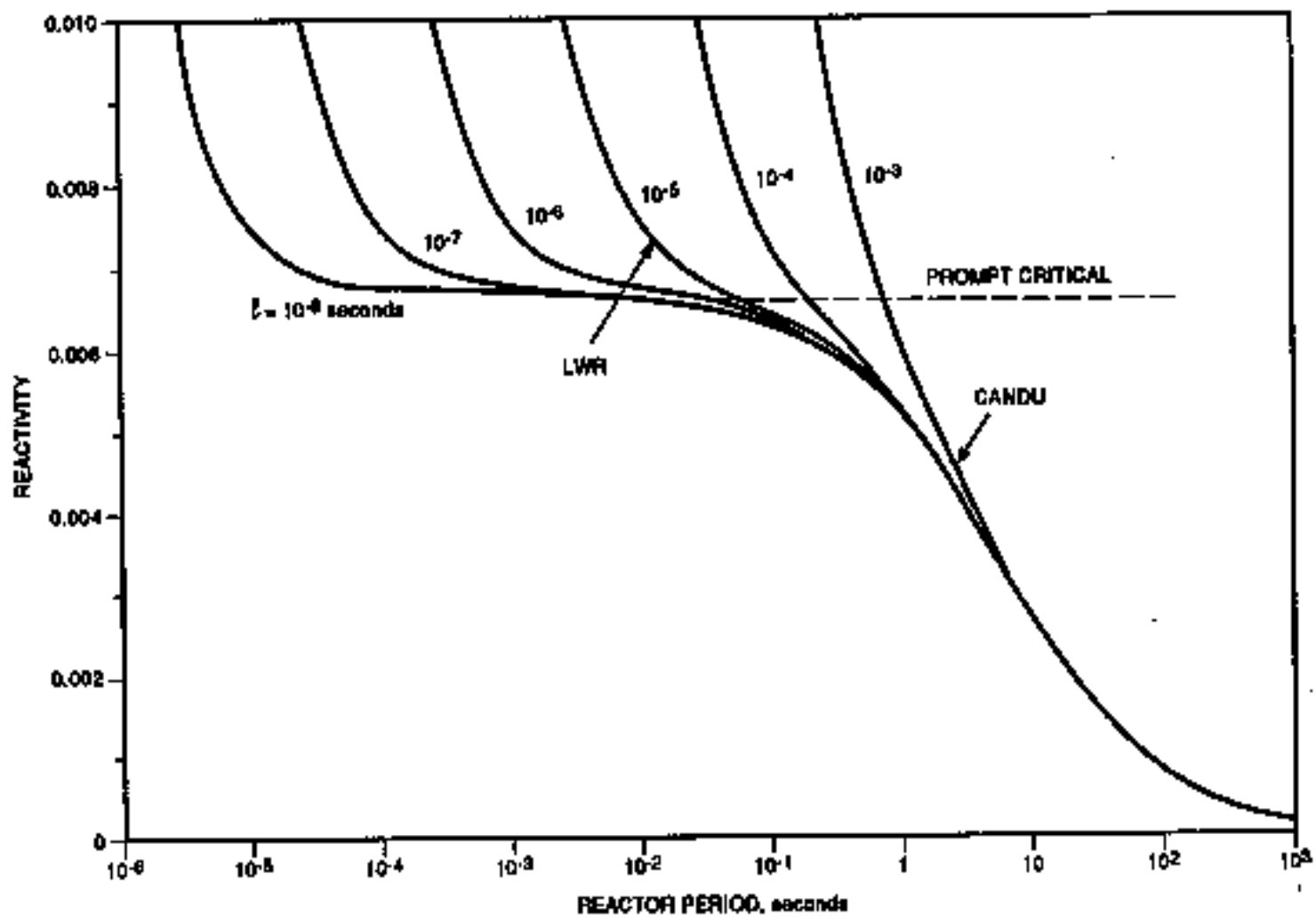



Consequences of Basic Features Pressure-Tube Reactor

- **The insulating gas gap between the pressure and calandria tubes allows the moderator to be at low temperature (~ 70 °C) and close to atmospheric pressure.**
- **Reactivity devices are located interstitially between fuel channels, in the low-pressure, low-temperature moderator – removing the possibility of pressure-assisted rod ejection, a distinctive safety feature.**
- **The relatively cool moderator provides a large and important heat sink in the case of a severe accident.**



Interstitial Positioning of Reactivity Devices

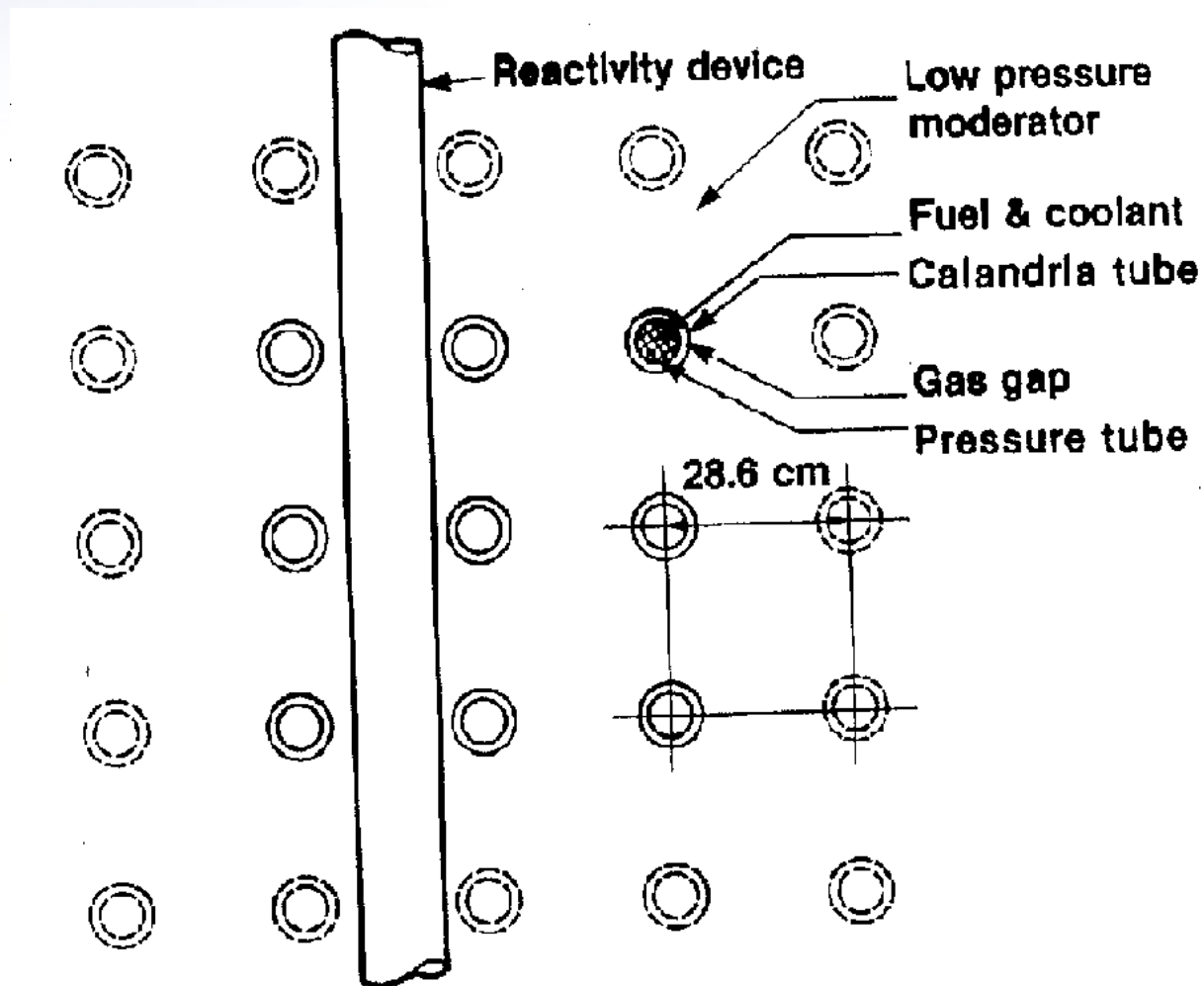



Consequences of Basic Features

On-Power Refuelling

- Old fuel is replaced by new fuel on a daily (or near-daily) basis \Rightarrow the core never has a large excess reactivity (except after first commissioning, for a small fraction of the reactor's operating life) – an additional safety feature; it also means that burnable poison is not required.
- The overall 3-d power distribution in the core is essentially constant for most of the reactor's operating life, with localized “ripples” superimposed (which are due to the different stages in the refuelling cycle at which fuel in different channels finds itself at any given time).
- CANDU fuel is in the form of short (50-cm-long) bundles of simple design.

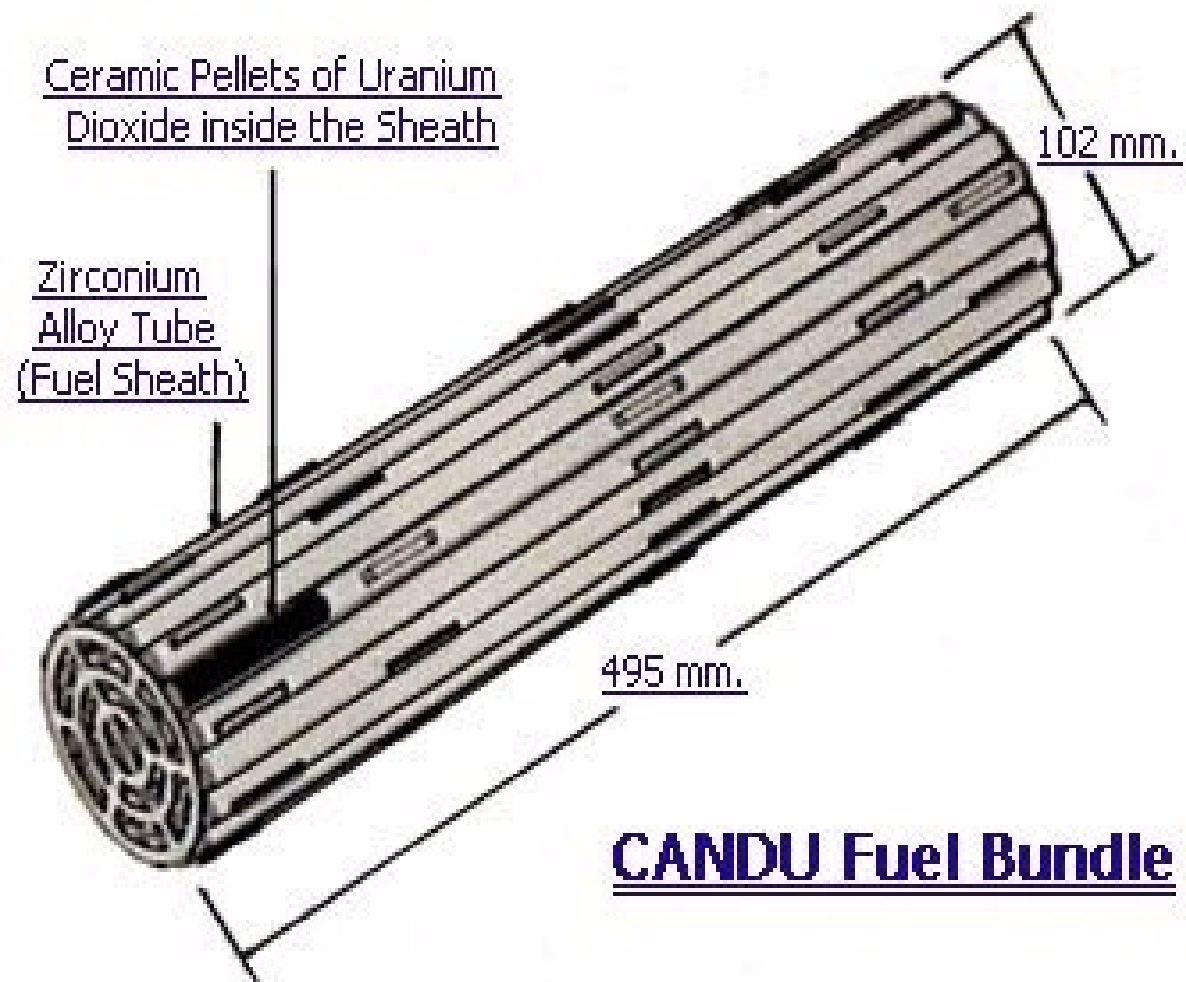

**Only 7 different components, short, easy to handle,
economical; ~ 20 kg (U).**



CANDU Modular Design

- The Figures “CANDU 6 Reactor Assembly” and “Schematic Face View of CANDU 6 Reactor” (next 2 slides) show the modular feature of the CANDU design.

CANDU 6 Reactor Assembly

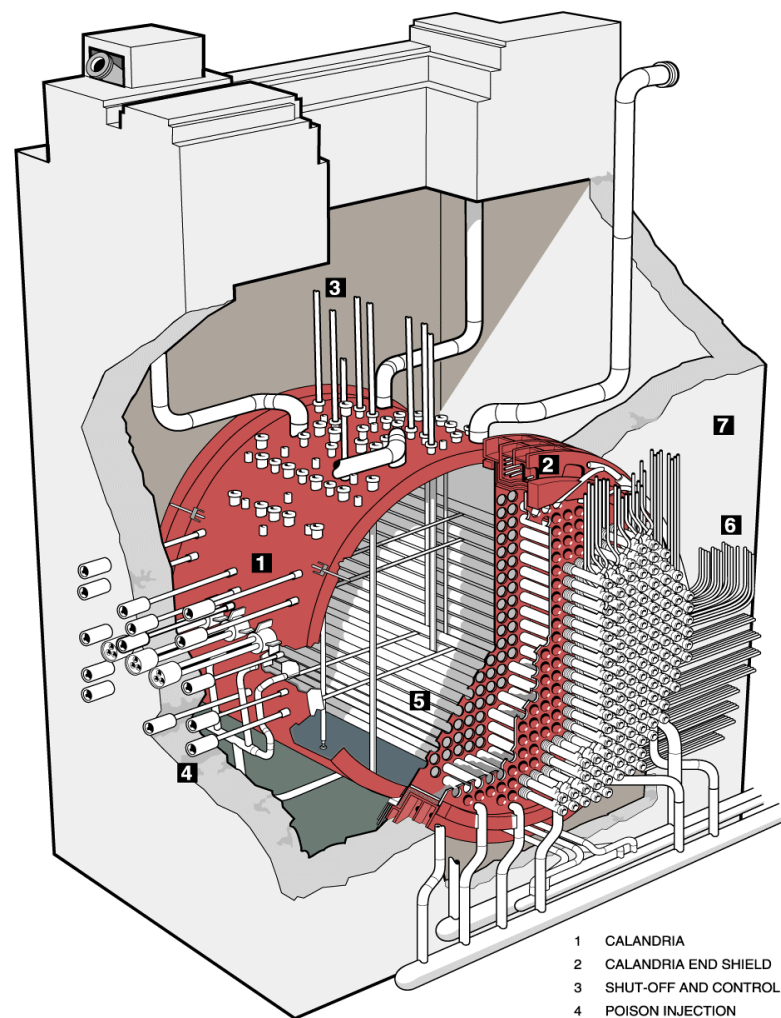

- 1 CALANDRIA
- 2 CALANDRIA END SHIELD
- 3 SHUT-OFF AND CONTROL RODS
- 4 POISON INJECTION
- 5 FUEL CHANNEL ASSEMBLIES
- 6 FEEDER PIPES
- 7 VAULT

970667-2

CANDU 6 Reactor Assembly

Schematic Face View of CANDU 6 Reactor

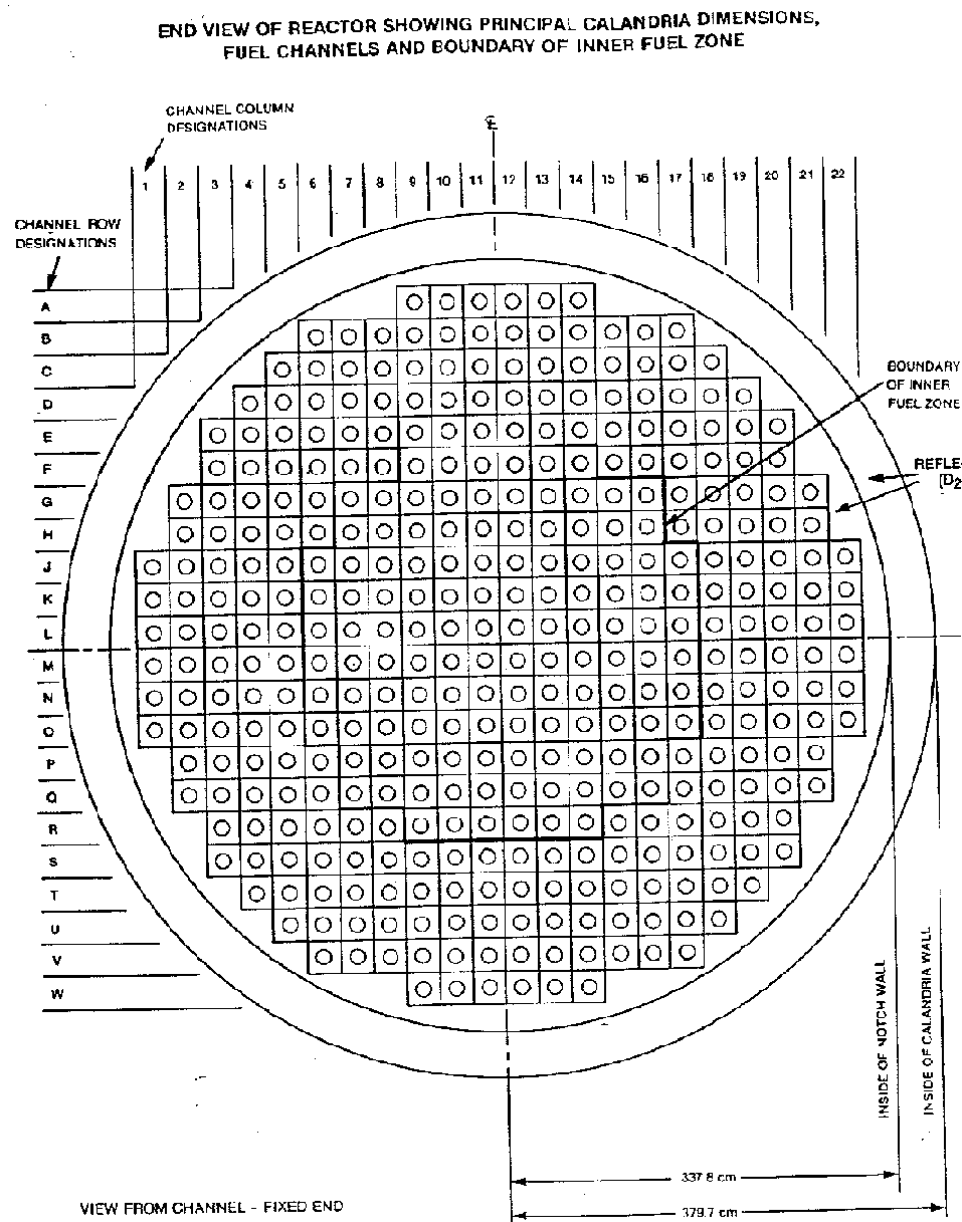



CANDU Modular Design

- **Essentially identical fuel channels are set on a square lattice of pitch 28.575 cm.**
- **The D₂O reflector is of average thickness ~ 65 cm**
- **The basic design can be scaled up or down in power by varying the number of fuel channels.**
- **The next slide shows the basic lattice cell of the current CANDU-6 design.**
- **Ratio of moderator volume to fuel volume ~ 16.4.**

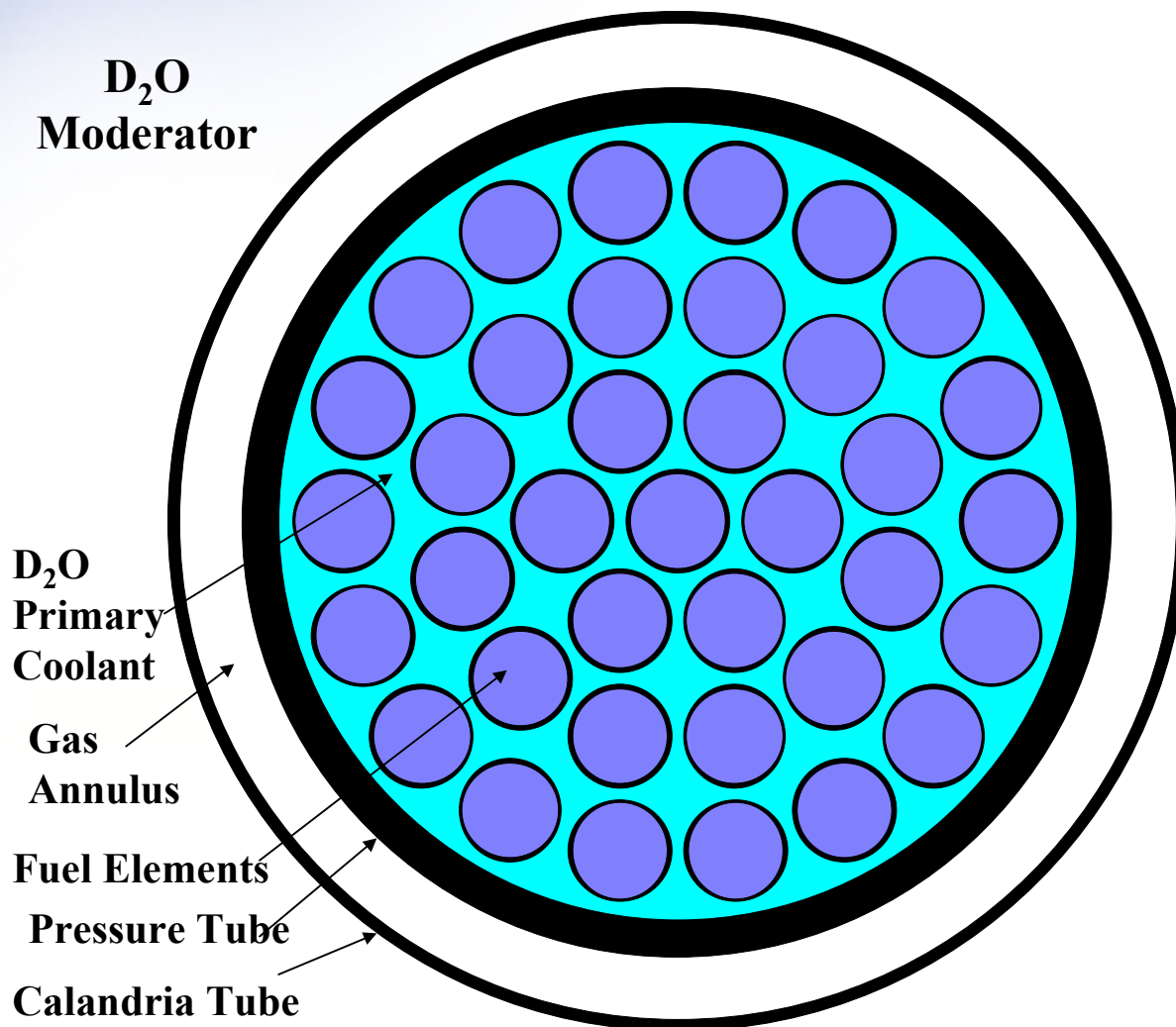

Face View of CANDU-6 Basic-Lattice Cell (not to scale)



Long-Term Reactivity Control

- The long-term means of reactivity control is on-power refuelling
- The reactivity decay rate is ~ 0.4 mk/FPD
- In CANDU 6, approximately 2 channels are refuelled per FPD, using an 8-bundle-shift push-through scheme
- But other refuelling schemes, e.g., 4-bs, 2-bs, 10-bs, have been used in other CANDUs. The refuelling is very flexible, it can be different in different channels or at different times.



Reactor Regulating System

The reactivity devices used for the purpose of control by the Reactor Regulating System (RRS) in the standard CANDU-6 design are the following:

- **14 liquid zone-control compartments**
- **21 adjuster rods**
- **4 mechanical control absorbers**
- **moderator poison.**

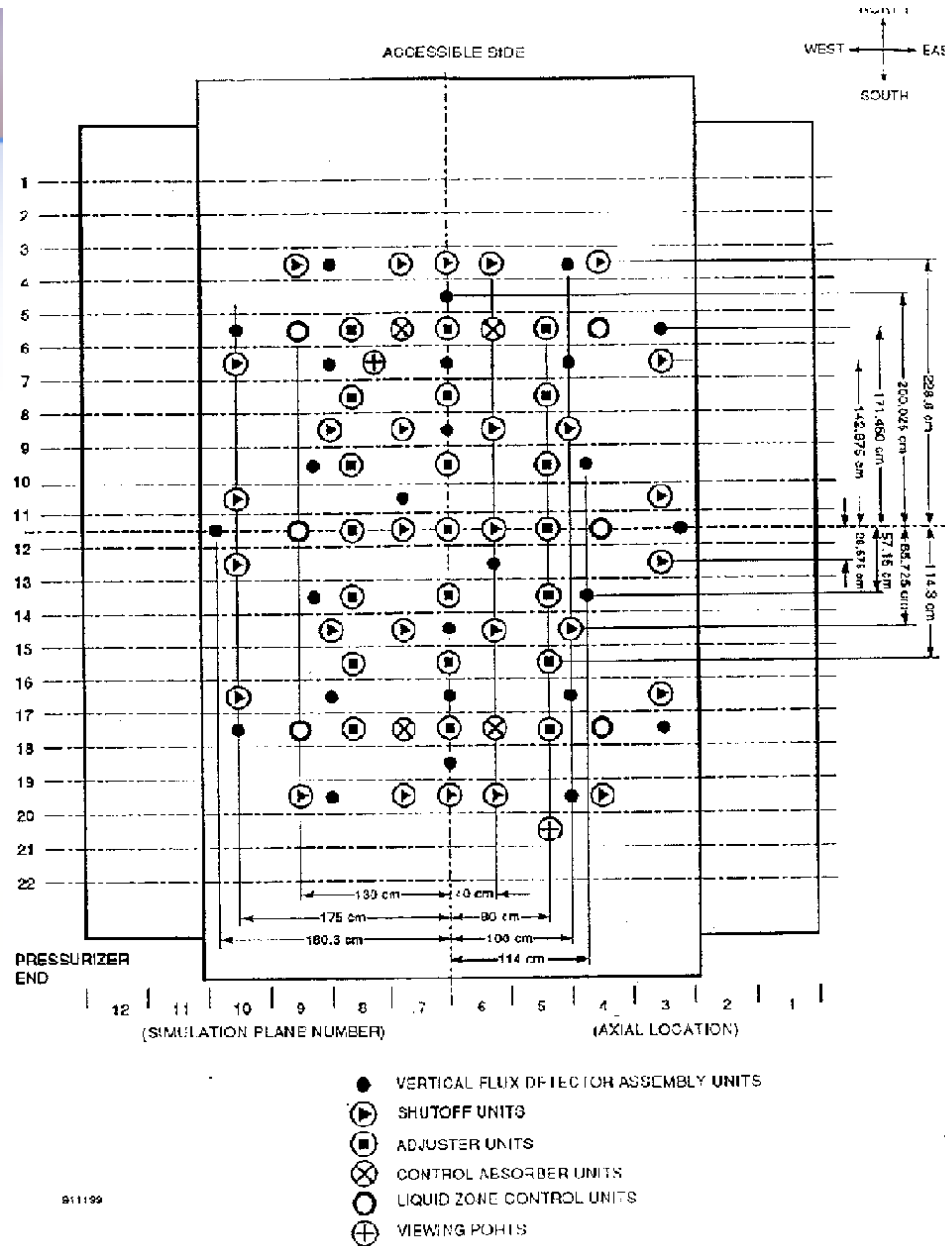

Plan View of Reactivity-Device Locations



Reactivity Devices – Liquid Zone Controllers

14 zone-control compartments (arranged in 6 vertical zone-control units) with variable amounts of light water used as absorber.



Liquid Zone-Control Units

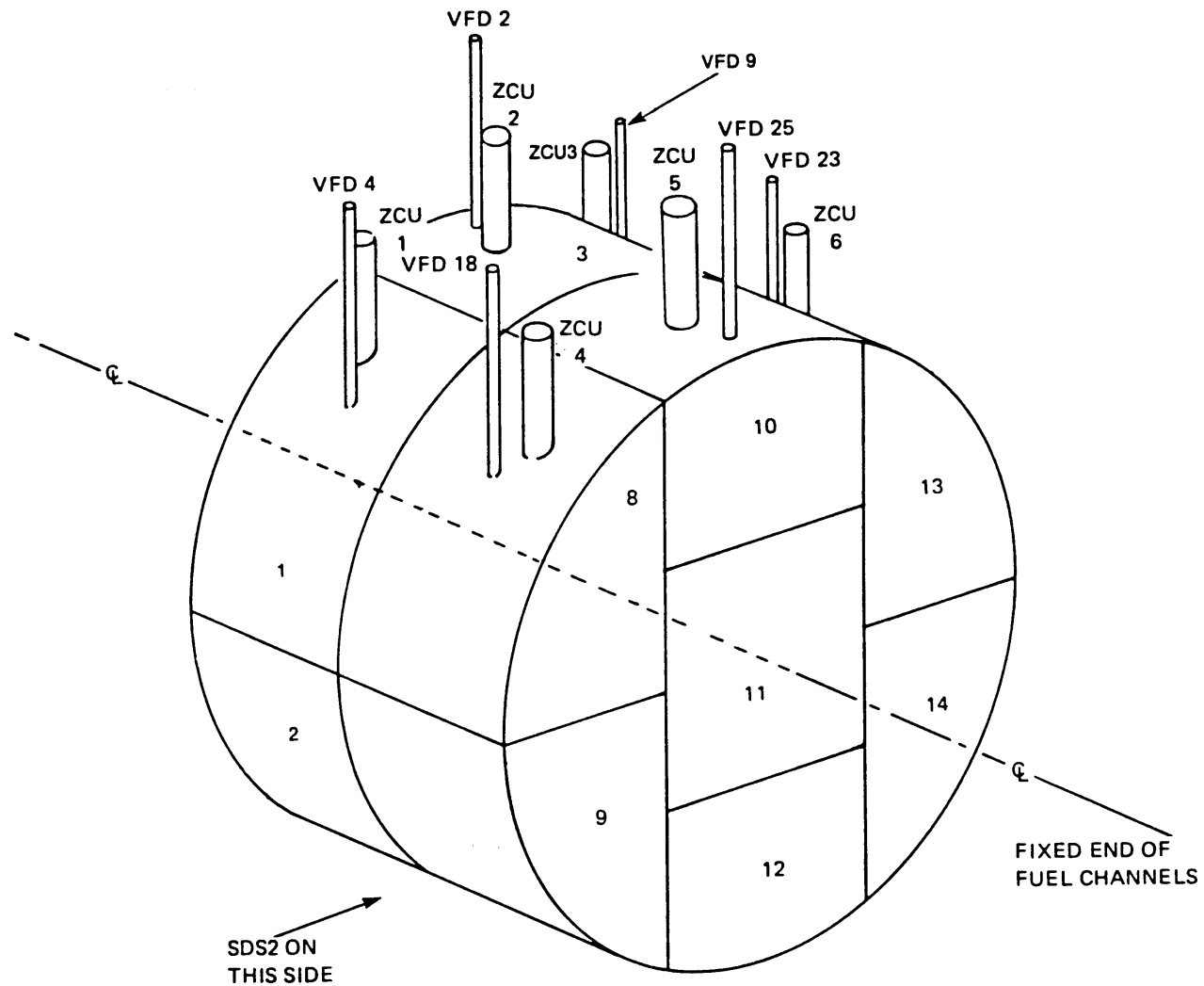



Liquid Zone-Control Compartments

2 3 4 5 6 7 8 9 10 11 12 13 14 15 16 17 18 19 20 21 22 23 24 25 26 27 28 29 30 31 32 33 34 35 36

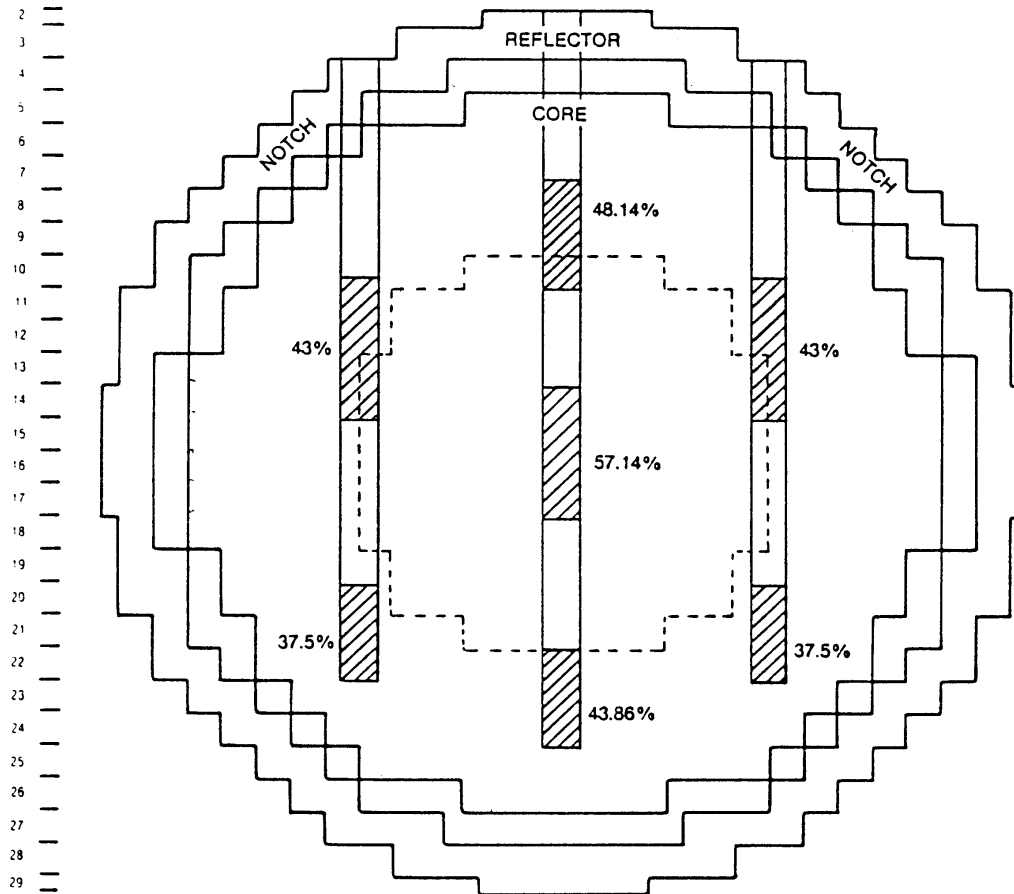

--- INNER CORE OUTER CORE BOUNDARY

Average Core Level
= 14.3 %



Reactivity Devices – Liquid Zone Controllers

Two functions:

- Bulk control – exercised every 0.5 s

The water fills are manipulated all in same direction:

- to keep reactor critical for steady operation, or
- to provide small positive or negative reactivity to increase or decrease power in a controlled manner

- Spatial control – exercised every 2 s

The water fills are manipulated differentially, to **shape** 3-d power distribution towards desired reference shape

Ideal working range: 20%-70% fill

Total reactivity worth of system (0-100% fill): ~ -7mk



Reactivity Devices – Adjuster Rods

- **21 adjuster rods**, made of stainless steel, or else cobalt (to produce ^{60}Co for medical applications).
- Provide positive reactivity beyond range of zone controllers, e.g., when refuelling is unavailable for a long period, or for xenon override.
- Normally in-core, they are withdrawn (vertically) when extra positive reactivity is required; total reactivity worth ~ 15 mk.
- Adjusters are moved in banks; maximum rate of change of reactivity per bank < 0.1 mk/s.
- Adjusters also help to **flatten** the power distribution, so that more total power can be produced without exceeding channel-power and bundle-power limits.
- Some reactor designs (Bruce A) have no adjusters.

Top View Showing Adjuster Positions

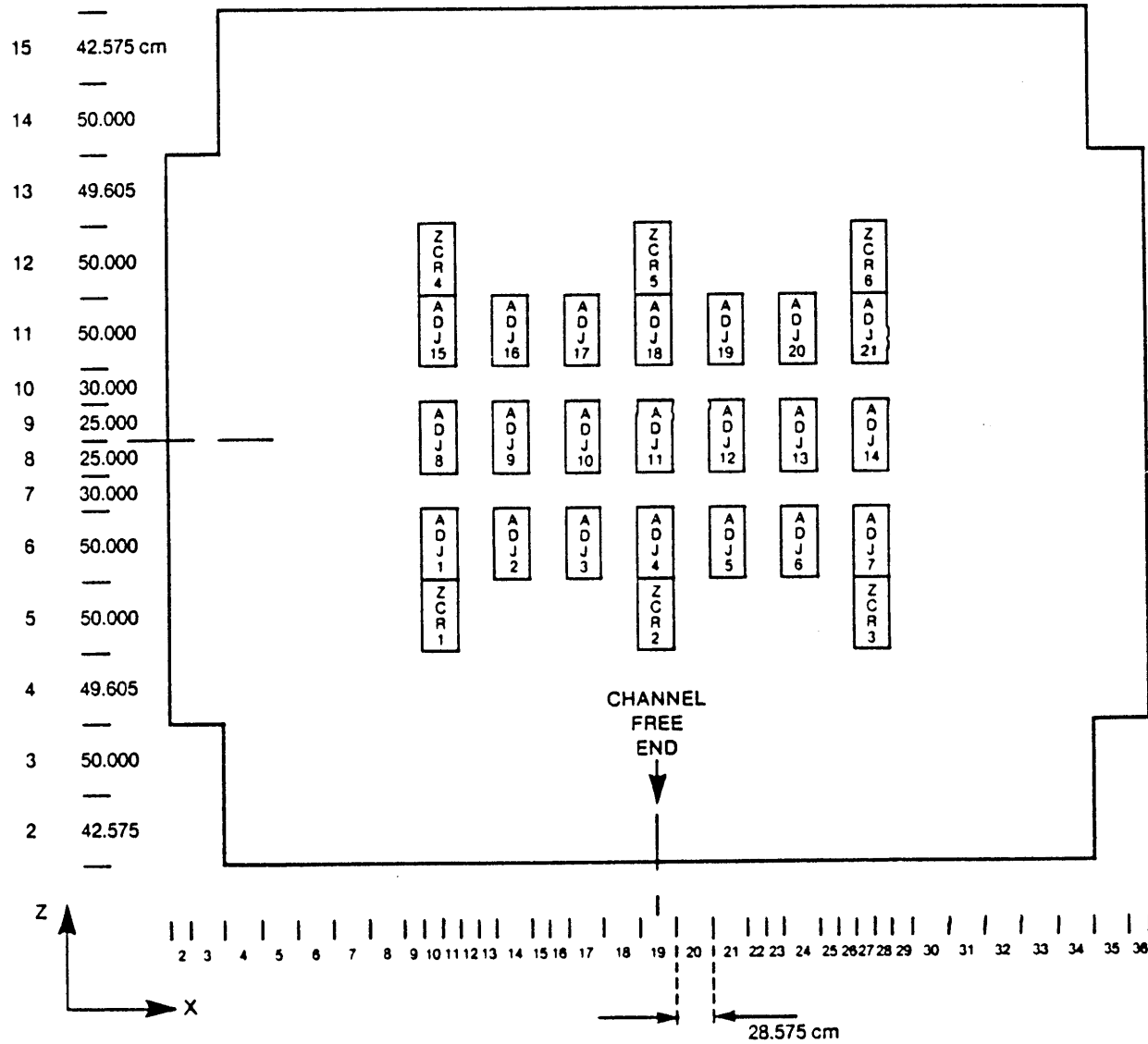

ADJ — ADJUSTER
ZCR — ZONE CONTROLLER

Face View Showing Adjuster Positions

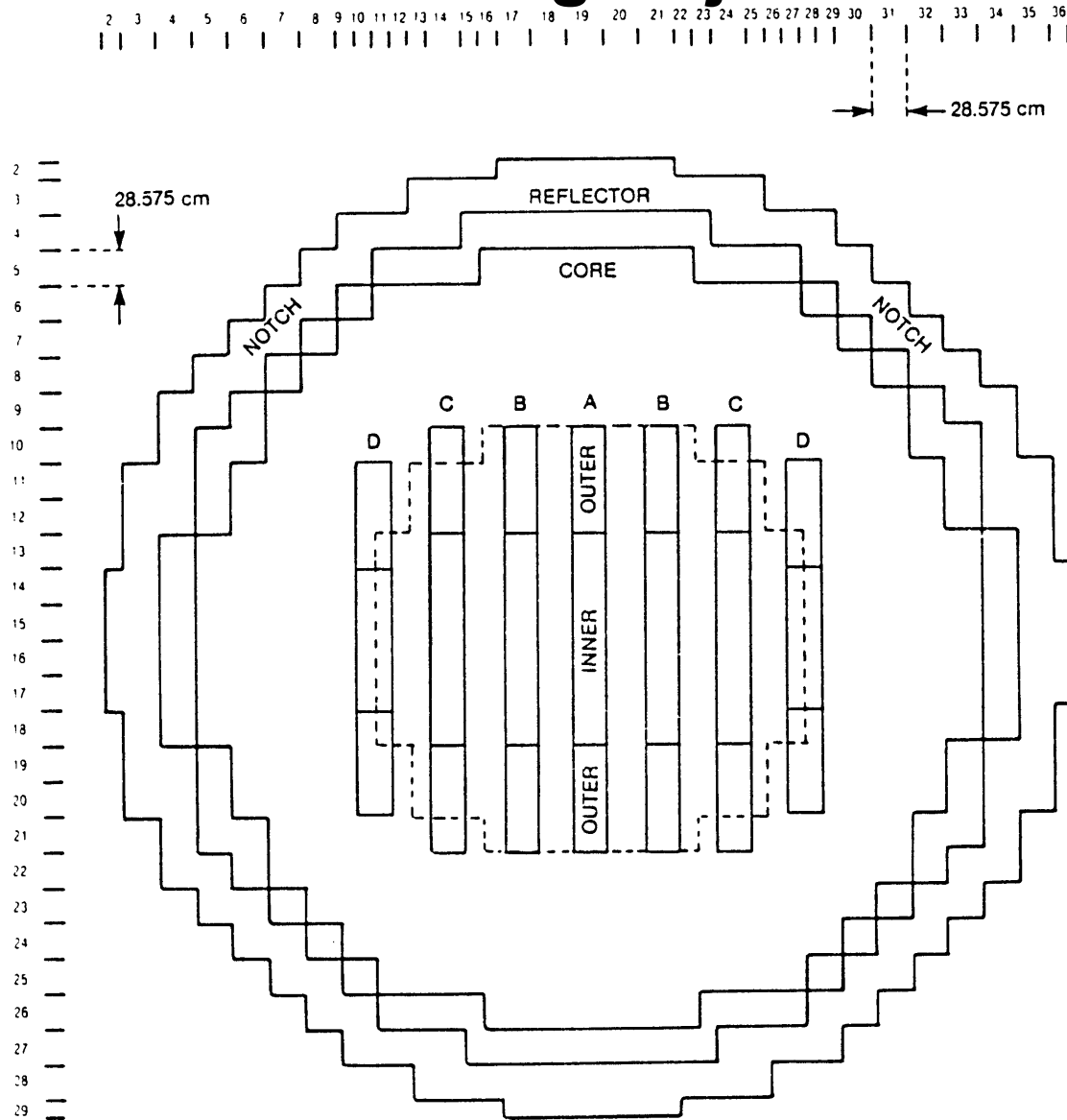



Reactivity Devices – Mechanical Control Absorbers

- **4 mechanical absorbers (MCAs)**, tubes of cadmium sandwiched in stainless steel – physically same as shutoff rods.
- MCAs normally parked out of core. They can be driven in pairs, or dropped in by gravity following release of an electromagnetic clutch.
- Total reactivity worth ~ -10 mk.
- They provide negative reactivity beyond the range of the zone controllers, or beyond their rate of negative-reactivity insertion (e.g., for rapid power reduction).



X = Mechanical Control Absorbers

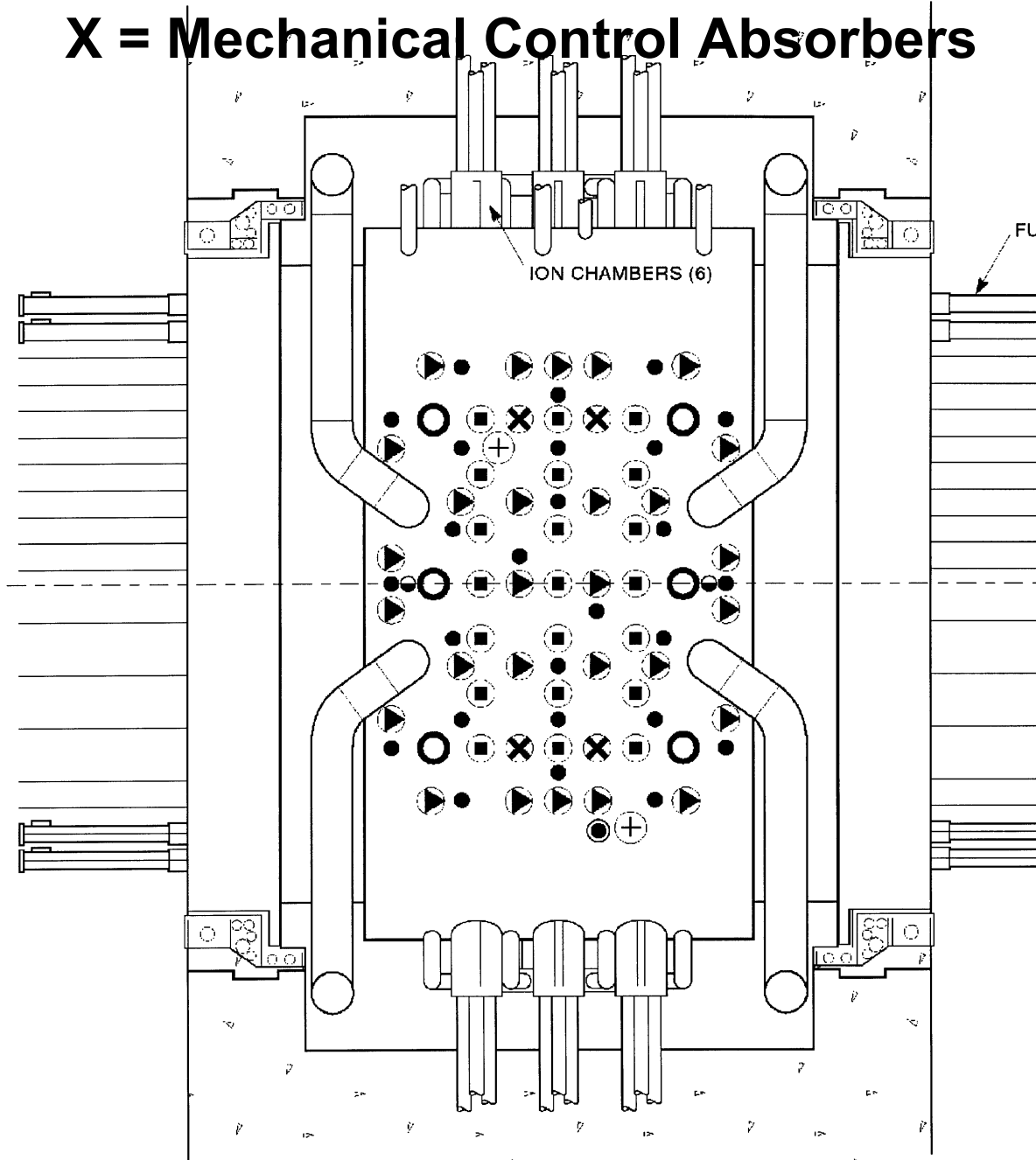



Reactivity Devices - Moderator Poison

- Boron or gadolinium can be added as a poison to the moderator, to compensate for excess reactivity:
 - in the initial core, when all fuel in the core is fresh, and
 - during and following reactor shutdown, when the ^{135}Xe concentration has decayed below normal levels.
- B is used in initial core, Gd is used following reactor shutdown. The advantage of Gd is that its burnout rate compensates for that of xenon build-up.
- Typical poison concentrations are in the range of only a few ppm, except in the Guaranteed Shutdown State.



Special Safety Systems

- **Not part of the RRS, there are 2 spatially, logically, and functionally separate special shutdown systems (SDS).**
- **These are used solely as emergency shutdown systems.**
- **Each system is to be independently capable of shutting down the reactor from any credible configuration.**
- **Each SDS has an availability factor of 0.999. The probability of shutdown not being available when needed is not credible (10^{-6}).**



Emergency Shutdown Systems - SDS-1

- 28 shutoff rods (SORs)
- Cadmium tubes sandwiched in stainless steel, diameter ~ 113 mm
- 24 SORs are ~ 5.4 m long, outermost 4 are ~ 4.4 m long
- SORs dropped vertically into core by gravity with initial spring assist. Full drop takes ~ 1.5 s.
- Static reactivity worth ~ -80 mk
- Reactivity insertion rate ~ -50 mk/s.

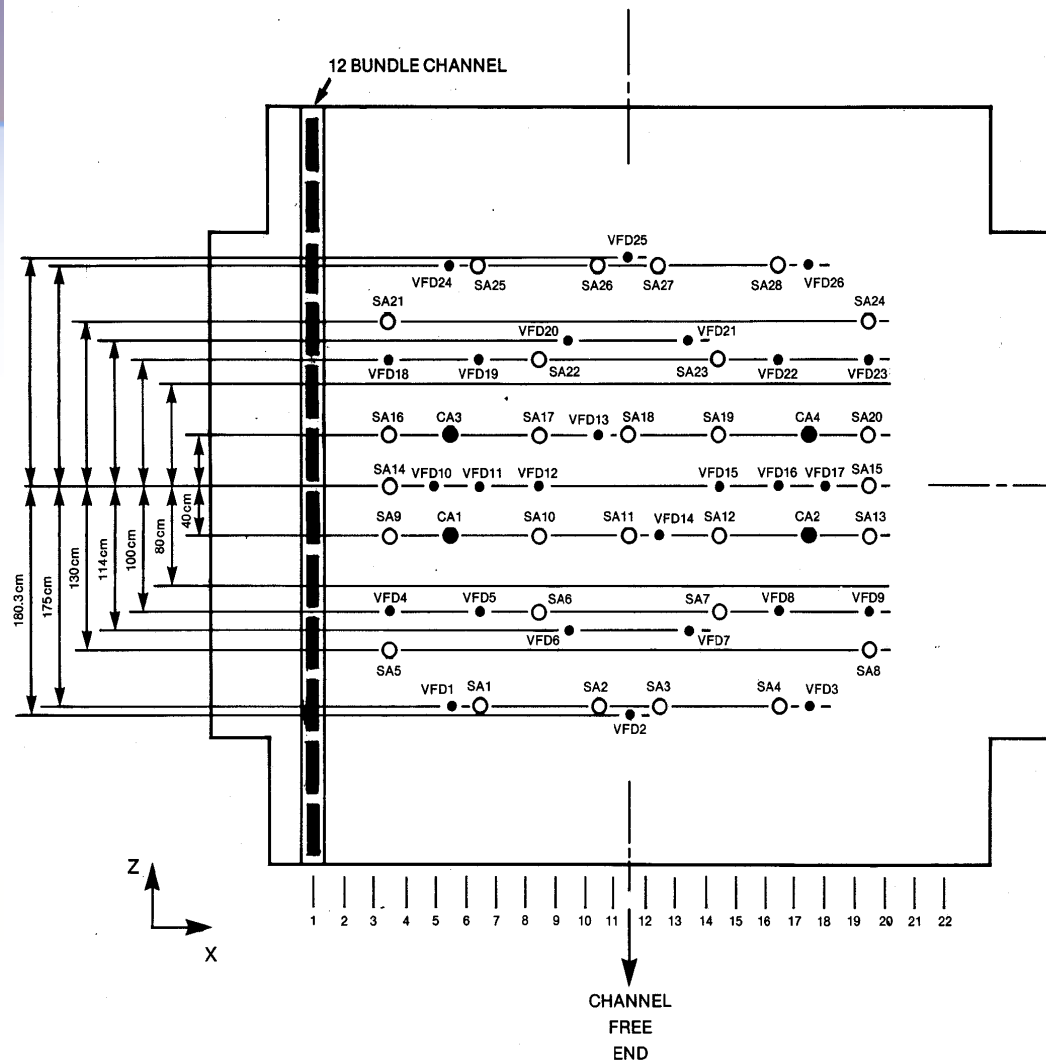

LEGEND

- VFD — VERTICAL FLUX DETECTOR ASSEMBLIES
- SA — SHUTOFF ROD GUIDE TUBES
- CA — CONTROL ABSORBER GUIDE TUBES

Reactor Top View Showing Shutoff-Rod Positions Pg 30

End-Elevation View of Adjusters and Shutoff Rods

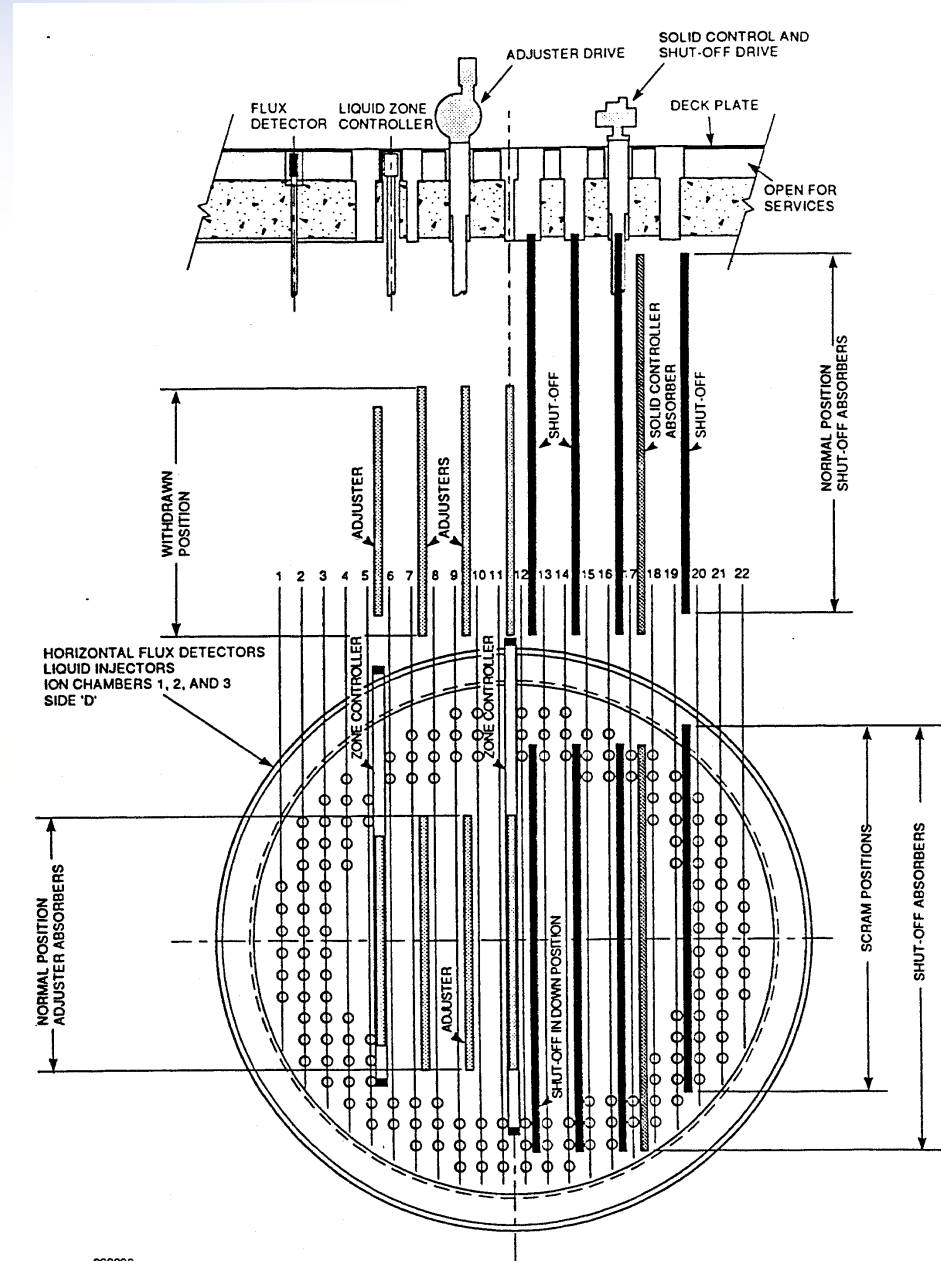



Emergency Shutdown Systems - SDS-2

- **SDS-2: high- pressure injection of gadolinium nitrate solution into moderator.**
- **Gadolinium solution normally held at high pressure in vessels outside calandria.**
- **Concentration ~8000 g of gadolinium per Mg of heavy water.**
- **Poison is injected into moderator through 6 horizontally oriented nozzles that span the core (see next Figure).**
- **Poison injection is complete within ~ 2s.**
- **Poison disperses rapidly through moderator.**
- **Reactivity worth after full mixing ~ -300 mk.**
- **Initial reactivity insertion rate ~ -50 mk/s.**

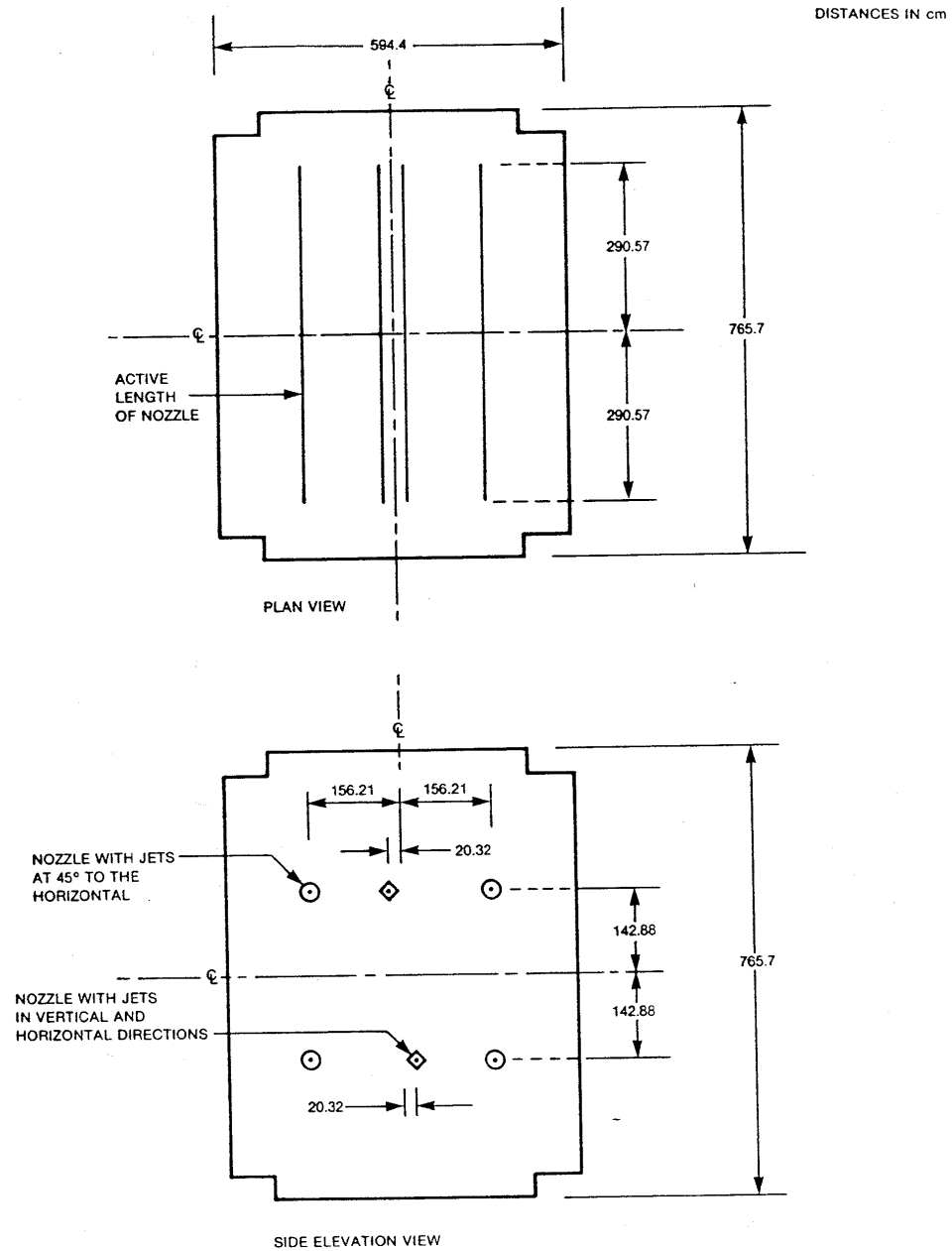
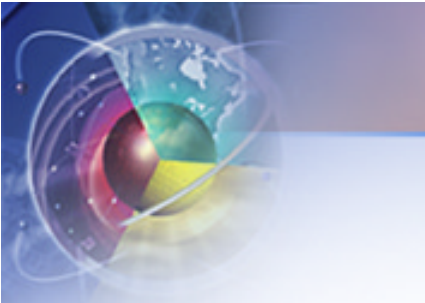

Location of Liquid-Poison-Injection Nozzles

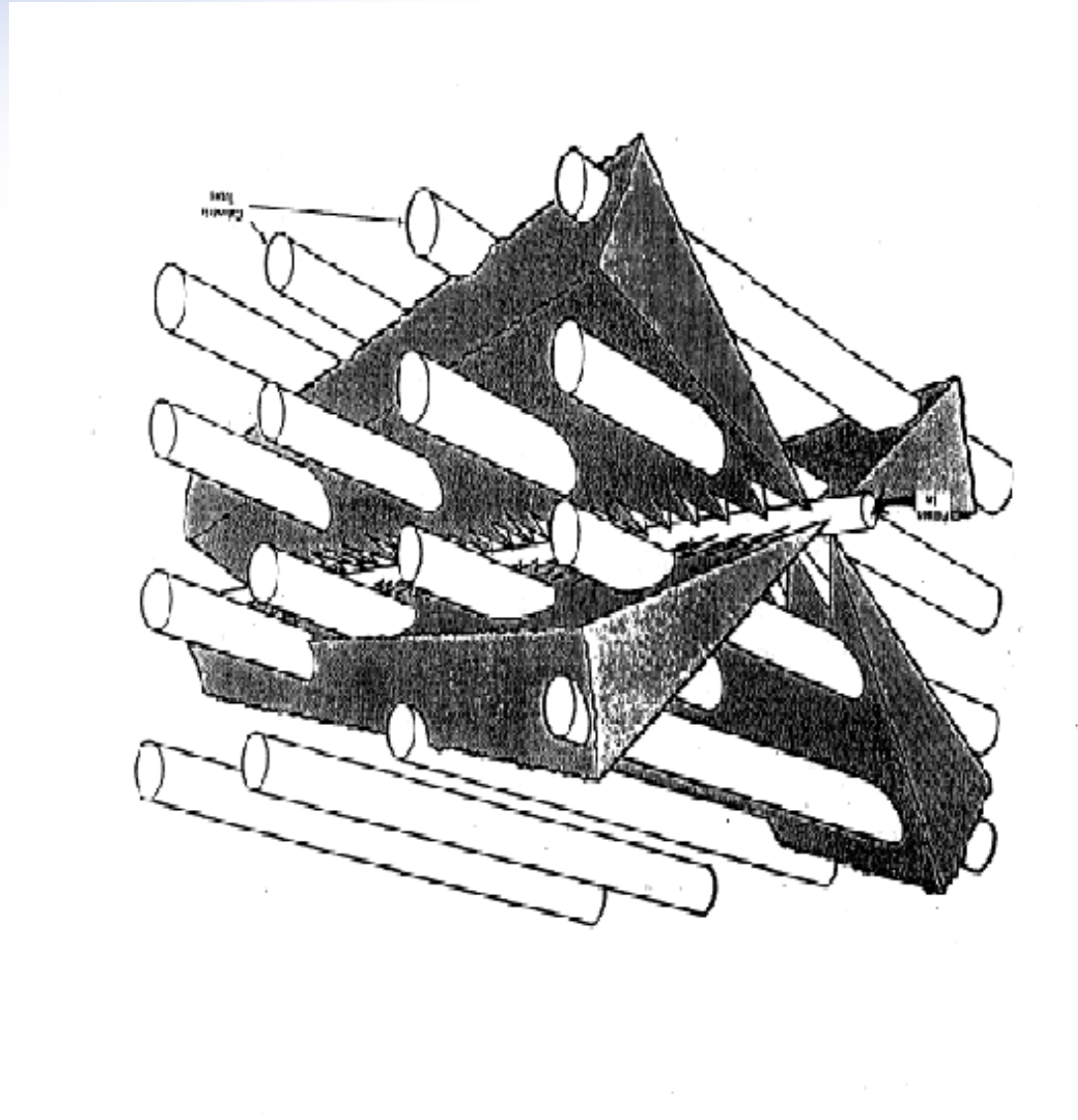

4 Poison Jets Emerging from Nozzle Pg 34



Device Reactivities and Insertion Rates

- The Table in the next slide summarizes the reactivity worths and reactivity-insertion rates of the various CANDU reactivity devices.
- The maximum positive reactivity-insertion rate achievable by driving all control devices together is about 0.35 mk/s, well within the design capability of the shutdown systems.



CANDU REACTIVITY DEVICES

Function	Device	Total Reactivity Worth (mk)	Maximum Reactivity Rate (mk/s)
Control	14 Zone Controllers	7	±0.14
Control	21 Adjusters	15	±0.10
Control	4 Mechanical Control Absorbers	10	±0.075(driving) -3.5 (dropping)
Control	Moderator Poison	—	-0.01 (extracting)
Safety	28 Shutoff Units	-80	-50
Safety	6 Poison-Injection Nozzles	>-300	-50



Detector Systems: Zone-Control Detectors

- **14 fast-response detectors, 1 per zone compartment**
- **Average of the 14 detector readings used as indicator of current power for bulk-control function.**
- **Distribution of individual detector readings, compared to reference readings, used for spatial control.**
- **Detectors give essentially “point” readings; they are calibrated every 2 minutes to zone fluxes from the flux-mapping system.**

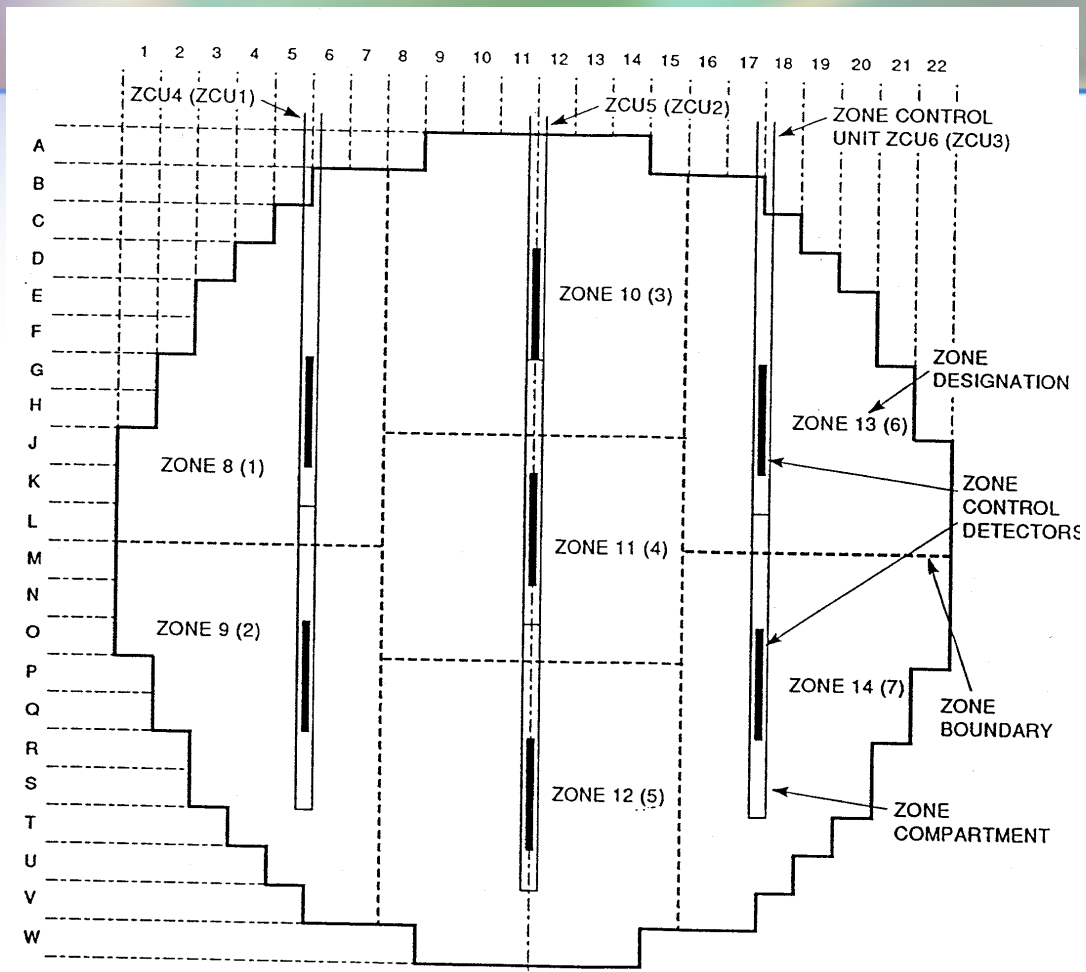

NOTES:

- 1 FACE VIEW FROM PRESSURIZER END. ZONES AND ZONE CONTROLLERS AT OTHER END (AWAY FROM PRESSURIZER) ARE GIVEN IN BRACKETS.
- 2 ZONE CONTROL DETECTORS ARE 3 LATTICE PITCHES LONG AND LOCATED IN VFDA's 1, 2, 3 AND 24, 25, 26 AXIALLY OUTBOARD FROM THE ZCUs.

920001

Location of Zone-Control Detectors

(Note: Detectors are not inside Compartments)



Neutronic Protection Systems

- **CANDU reactors are equipped with protection systems which detect an emergency situation and actuate the safety system(s).**
- **There is a separate neutronic protection system for each SDS.**
- **Each protection system is triplicated [has 3 separate “logic” (or “safety”) channels] and consists of out- of- core ion chambers and in- core self- powered detectors.**
- **Logic channels D, E, and F for SDS-1; G, H, and J for SDS-2.**
- **In each protection system, it suffices that 2 of 3 logic channels be “tripped” for the corresponding SDS to be actuated.**



Out-of-Core Ion Chambers

- There are 3 ion chambers in each protection system, 1 per logic channel.
- They are located at the outside surface of the calandria (see next Figure).
- Each ion chamber trips on rate of change of logarithm of flux ϕ , i.e., of $d(\ln \phi)/dt$ (setpoint e.g. 10% per second for SDS-1 in the CANDU 6).

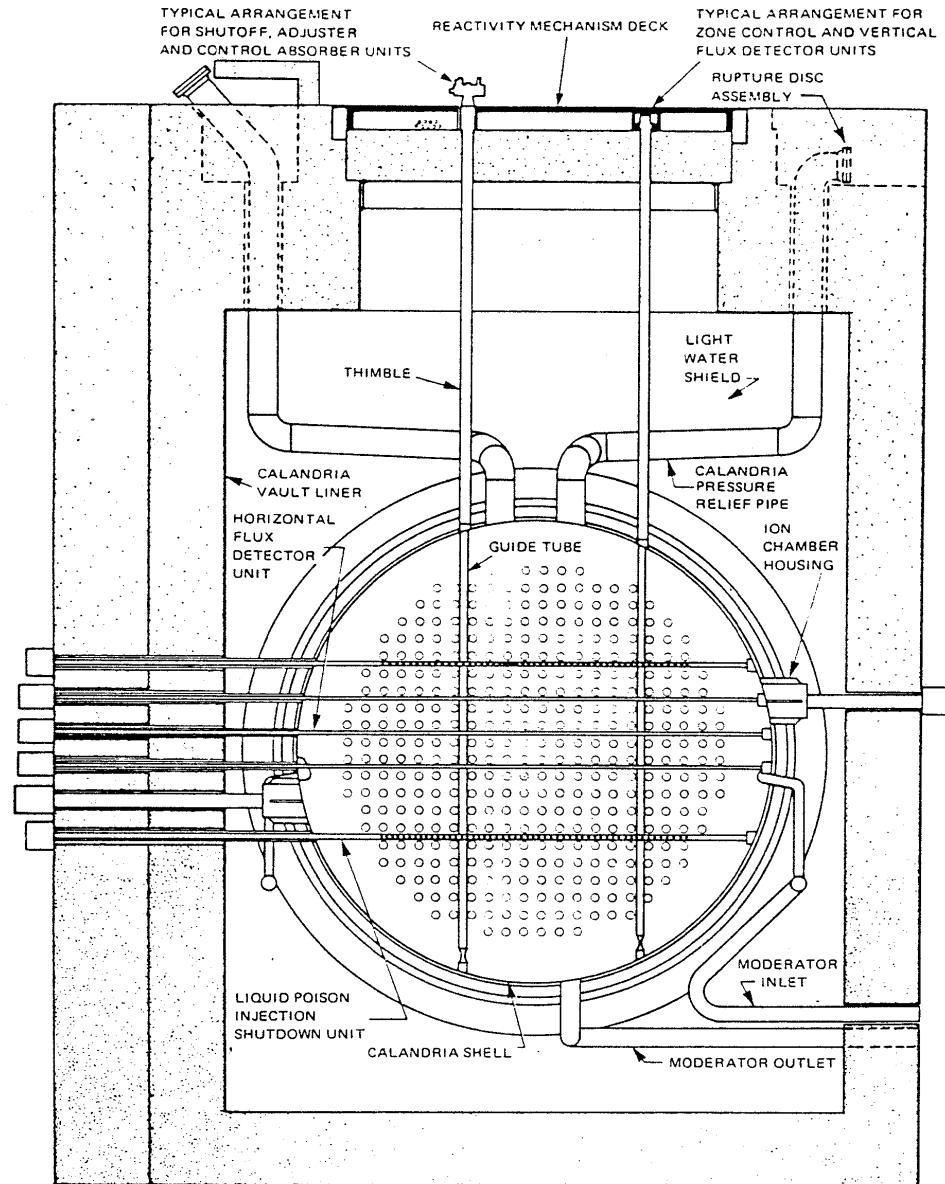

Ion-Chamber Locations



Regional Overpower Protection (ROP) Detectors

- **There are also fast- response (platinum or inconel) in- core detectors in each protection system.**
- **34 SDS-1 in-core detectors in vertical assemblies, and 24 SDS-2 detectors in horizontal assemblies (see next 2 Figs).**
- **The detectors are distributed among the various logic channels: channels D, E and F contain 11 or 12 detectors each, channels G, H, and J contain 8 each.**
- **The detectors trip on high neutron flux: any 1 detector reading reaching a pre- determined setpoint trips the corresponding logic channel.**
- **The detector trip setpoints are determined by an extensive analysis to protect against loss- of- regulation accidents.**

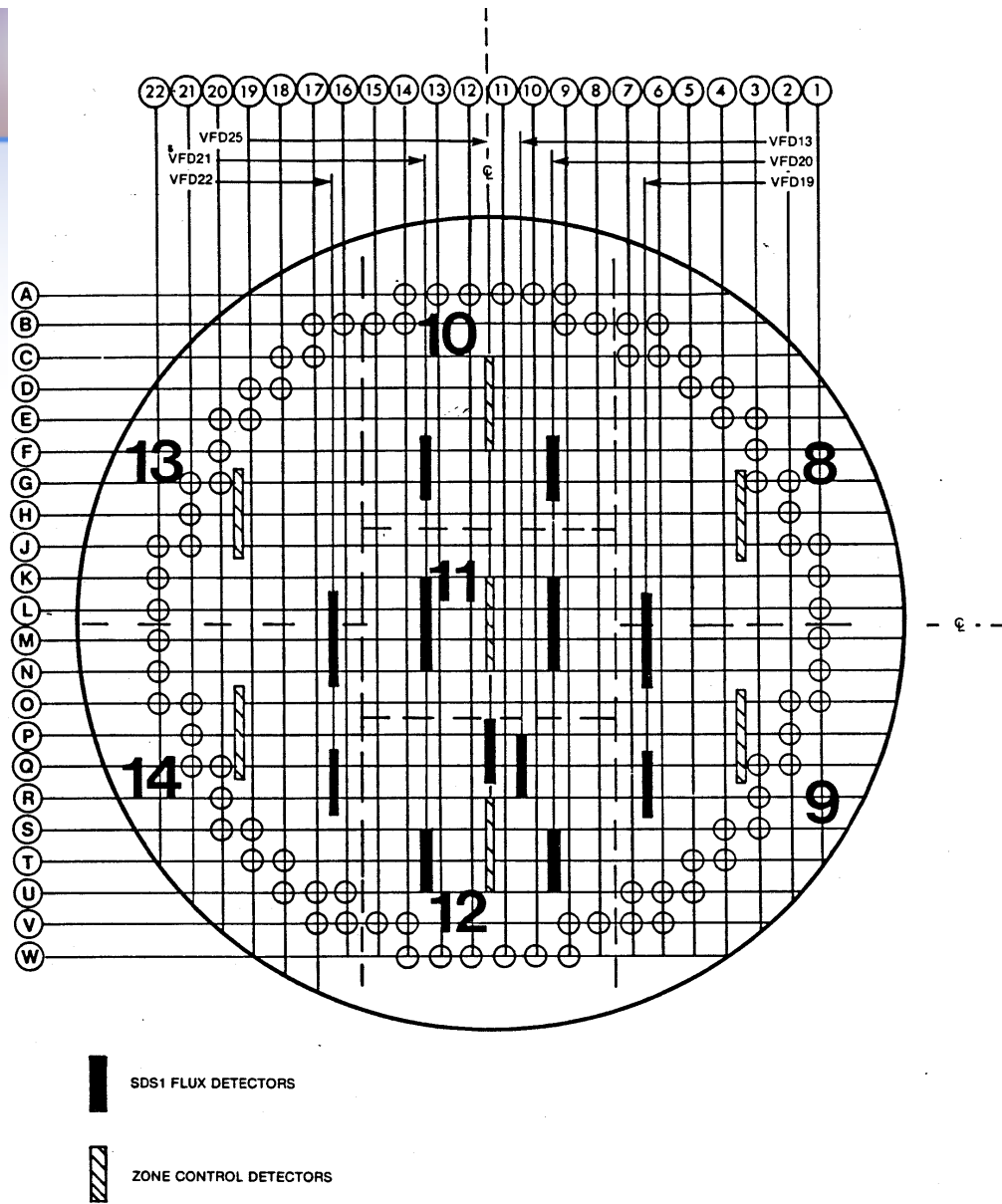

3.3

FIGURE 3-13-2 (continued) — VIEW 3

Some SDS1 In-Core-Detector Locations ^{Page 43}

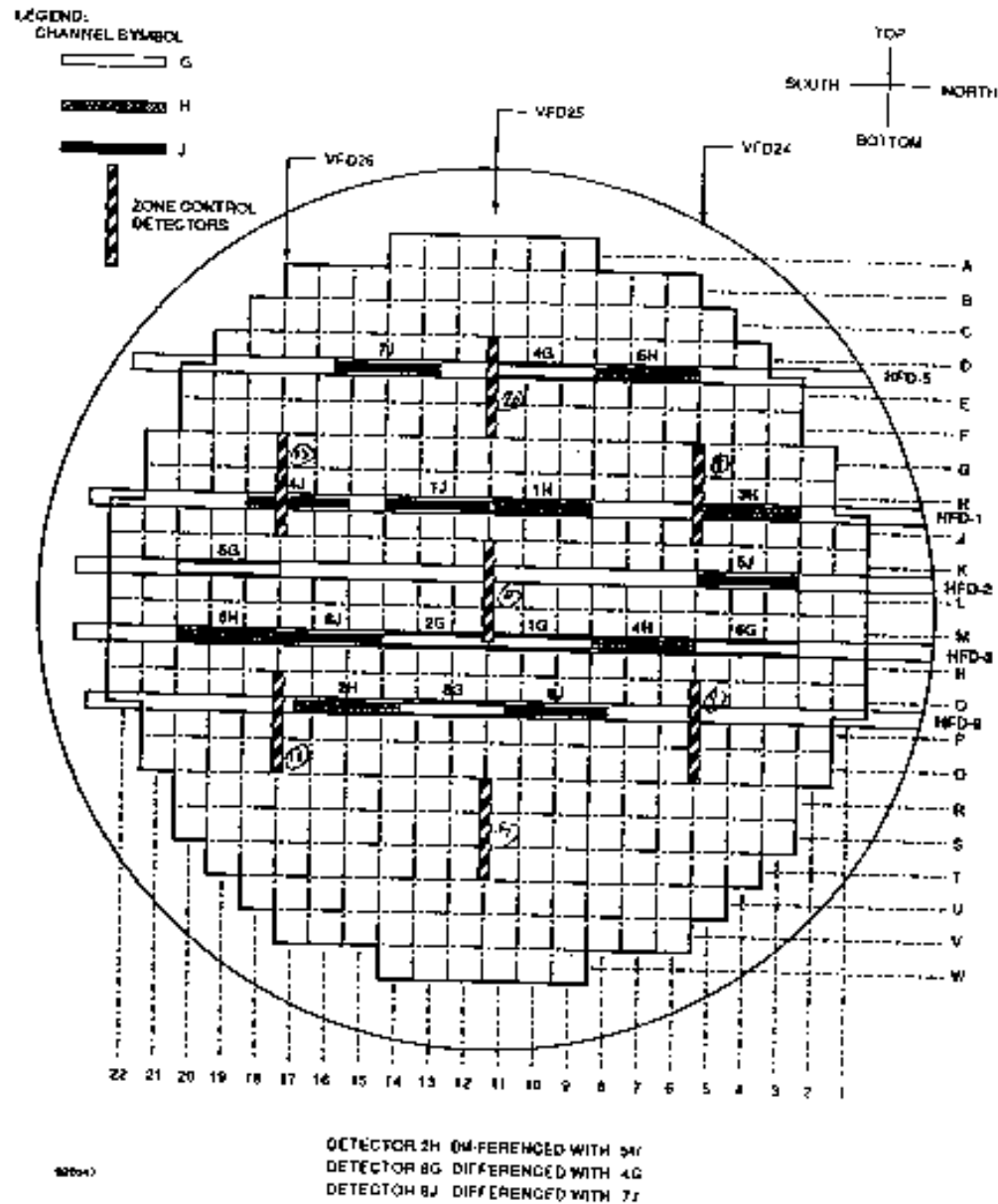

Some SDS2 In-Core-Detector Locations



Triplicated Tripping Logic

- **The tripping logic of each triplicated protection system is as follows (see next Figure):**
- **One ion chamber can trip its logic channel on high log rate, or any 1 detector in the logic channel can trip the channel on high flux.**
- **Any 2 tripped channels will actuate the associated shutdown system.**
- **The triplicated logic reduces the chance of a spurious trip, and allows the testing of the system on-line.**

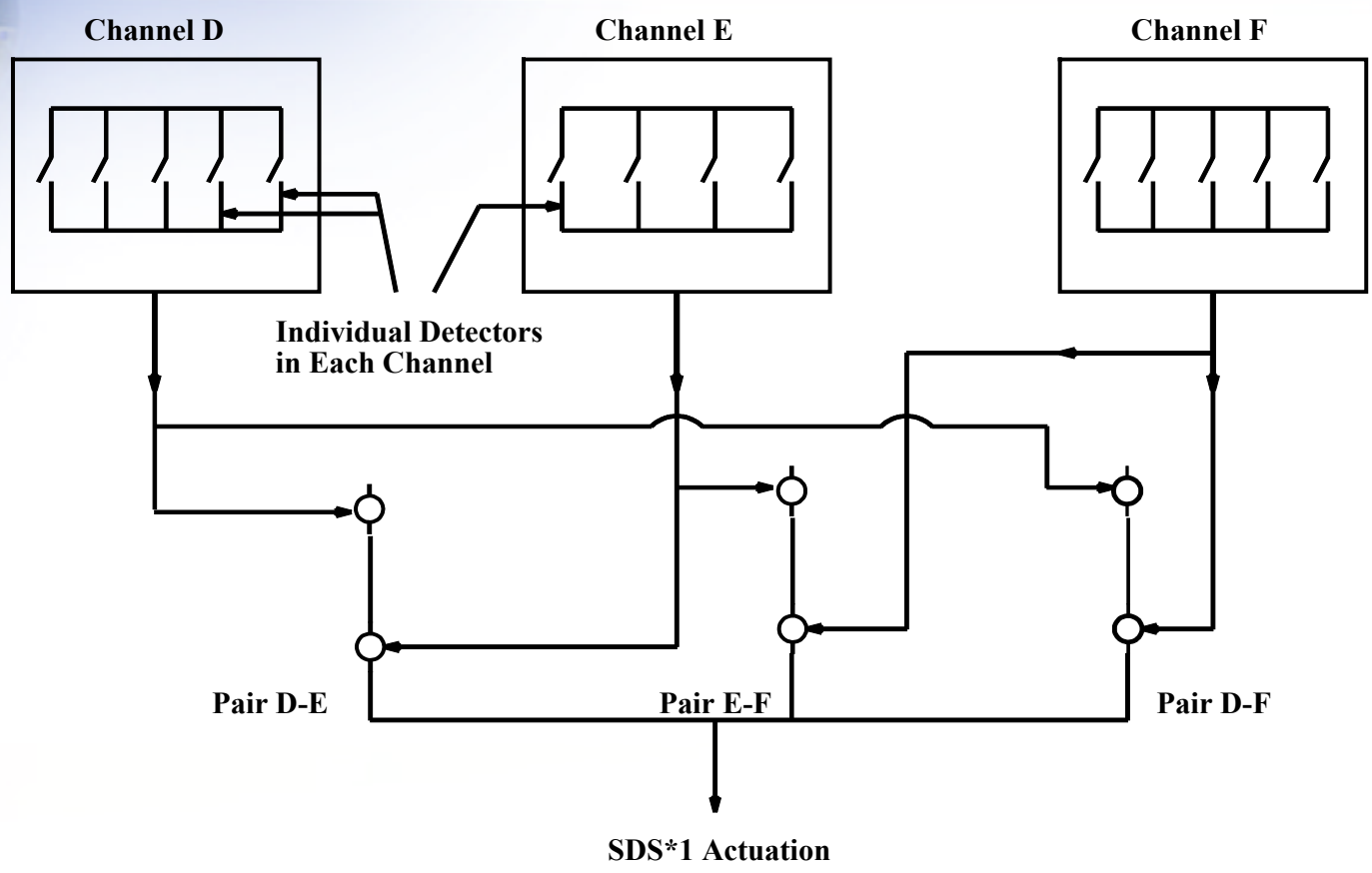

Tripllicated Tripping Logic for SDS-1



Flux-Mapping System

- The CANDU 6 is provided with a flux- mapping system to synthesize the 3- d flux distribution in the reactor from in- core detector readings.
- The system consists of 102 vanadium detectors (1 lp long) at various positions in the core (see next Figure).
- The flux- mapping procedure assumes the 3-d flux distribution can be written as a linear combination of a number of basis functions or flux modes.
- The mode amplitudes are determined by a least- squares fit of the calculated fluxes at the 102 detectors to the measured fluxes. The 3-d flux distribution can then be reconstructed.
- The flux-mapping modes consist of 15 pre- calculated harmonics of the neutron diffusion equation (see 2nd Figure following) and some reactivity-device modes.
- Flux mapping is done automatically every 2 minutes.

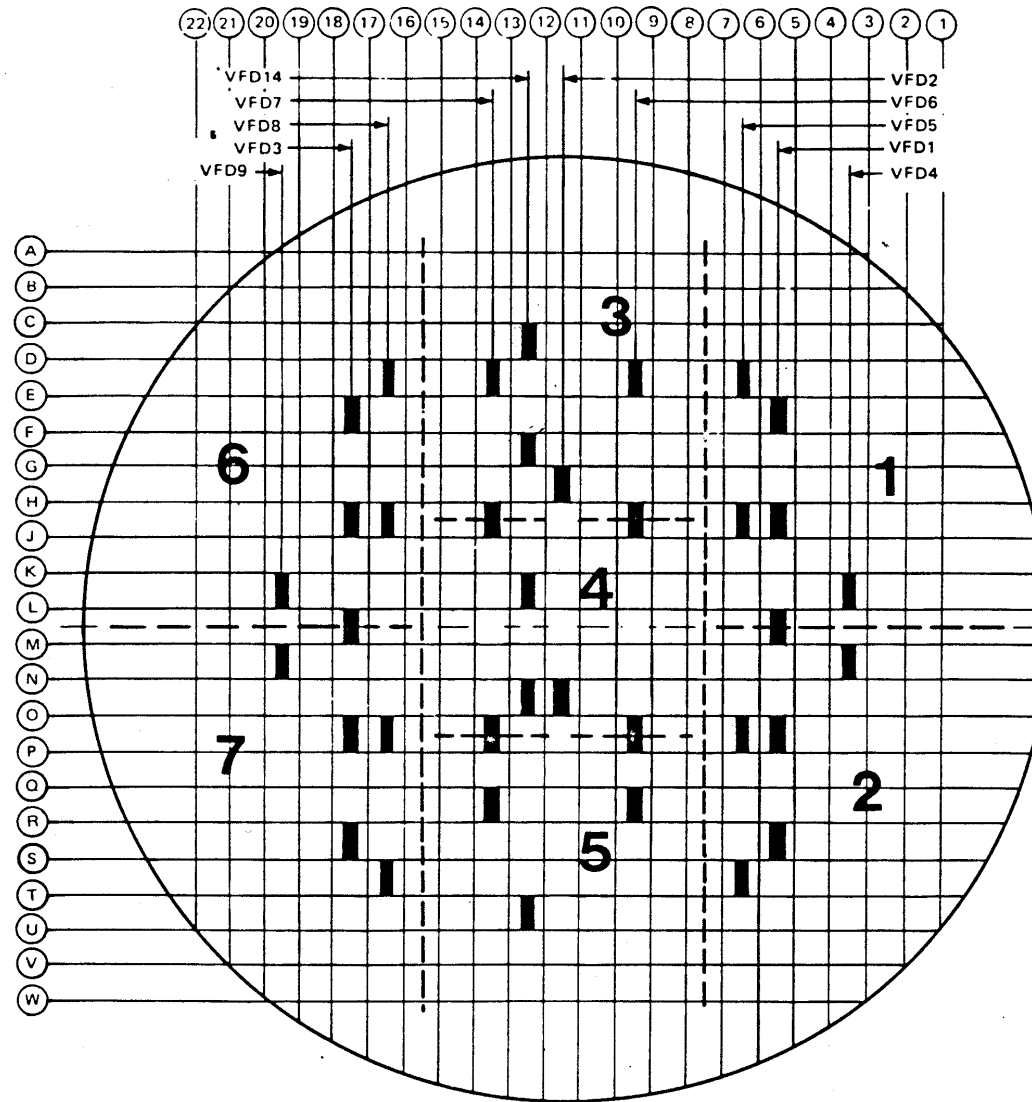

Some Flux-Mapping Detectors



MODE NUMBER	DESIGNATION	SUBCRITICALITY MK	MODE SCHEMATIC (IDEALIZED)
0	Fundamental	0	
1	First Azimuthal-A	16.2	
2	First Azimuthal-B	16.9	
3	First Axial	27.1	
4	Second Azimuthal-A	44.0	
5	Second Azimuthal-B	47.0	
6	First Azimuthal-A x First Axial	46.9	
7	First Azimuthal-B x First Axial	47.7	
8	First Radial x Second Axial-A	66.3	
9	First Radial x Second Axial-B	80.6	

Harmonic Modes for Flux Mapping



CANDU Physics Computational Basis

- CANDU reactor physics rests on a “3-legged stool”: 3 stages of calculations
- The 3 computer codes are part of the “Industry Standard Toolset” (IST)
- The code suite has been validated for the phenomena of interest in the standard CANDU-6, using experiments in research reactors (e.g., ZED-2 at CRL) and measurements in operating reactors (e.g., CANDU-6)

Lattice Code

- WIMS-IST
- multi-group, 2-D transport code

Reactor Code

- RFSP-IST
- 2-energy group diffusion theory

Reactivity-Device Code

- DRAGON-IST
- multi-group, 3D transport code

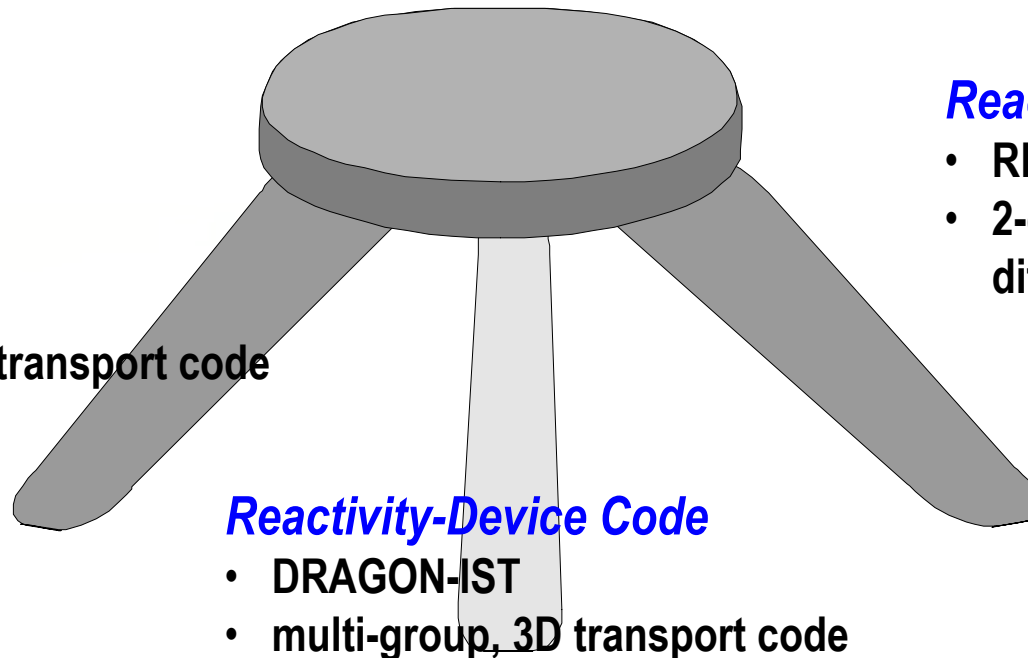

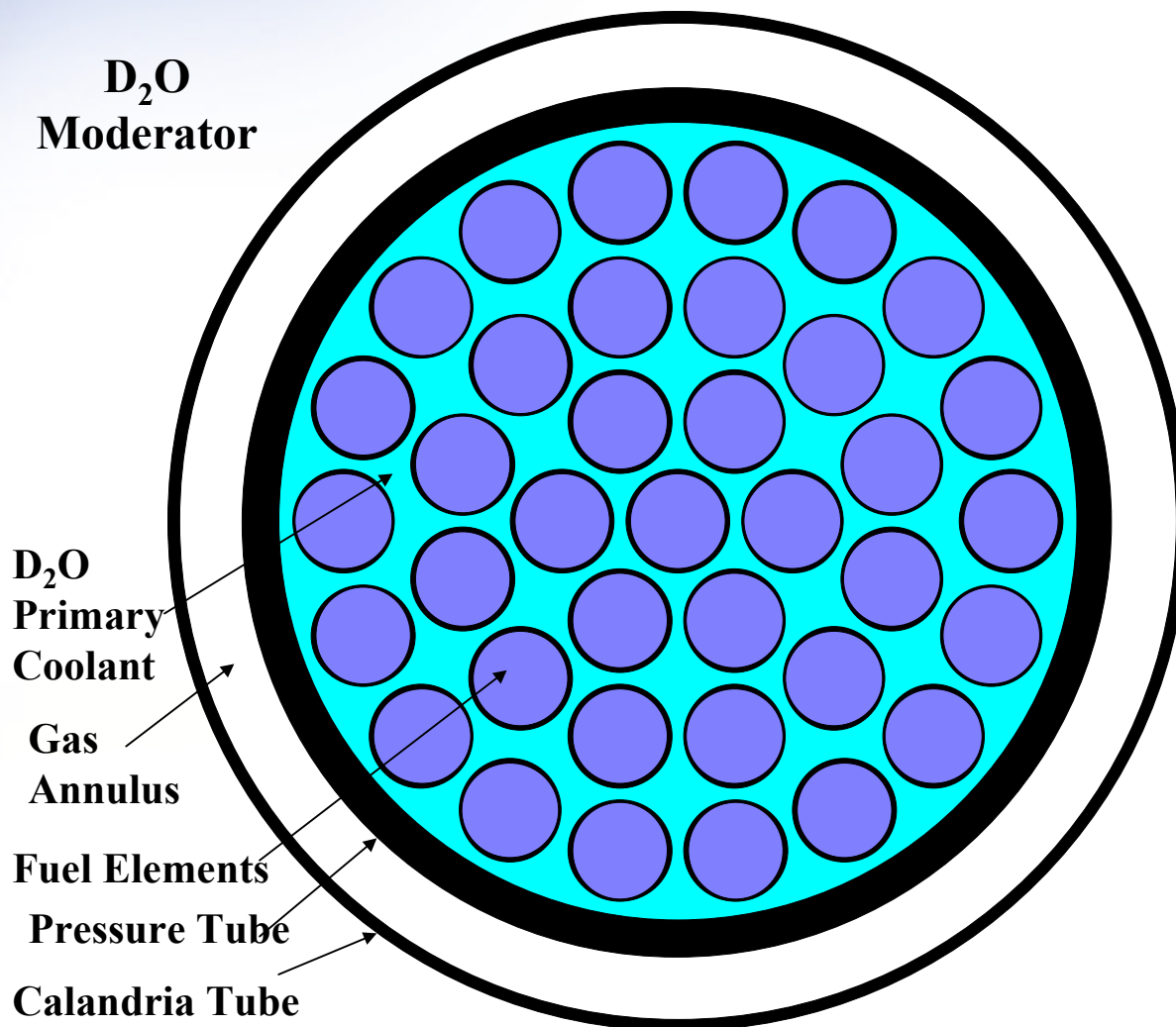

Basic-Lattice Cell (no reactivity device, not to scale)



Lattice Code

WIMS-IST

- **Calculates cell-averaged properties of basic lattice (without reactivity devices, except perhaps moderator poison)**
- **Uses 2-d neutron transport theory**
- **Uses an ENDF-B/VI 89-group nuclear data library, assembled with NJOY.**
- **Calculates nuclide depletion with burnup**
- **Provides cell nuclear cross sections for various reference or perturbed values of lattice parameters, e.g., coolant density, fuel temperature, moderator poison, etc.**
- **Cross sections are fed to core model.**



Interstitial Reactivity Device

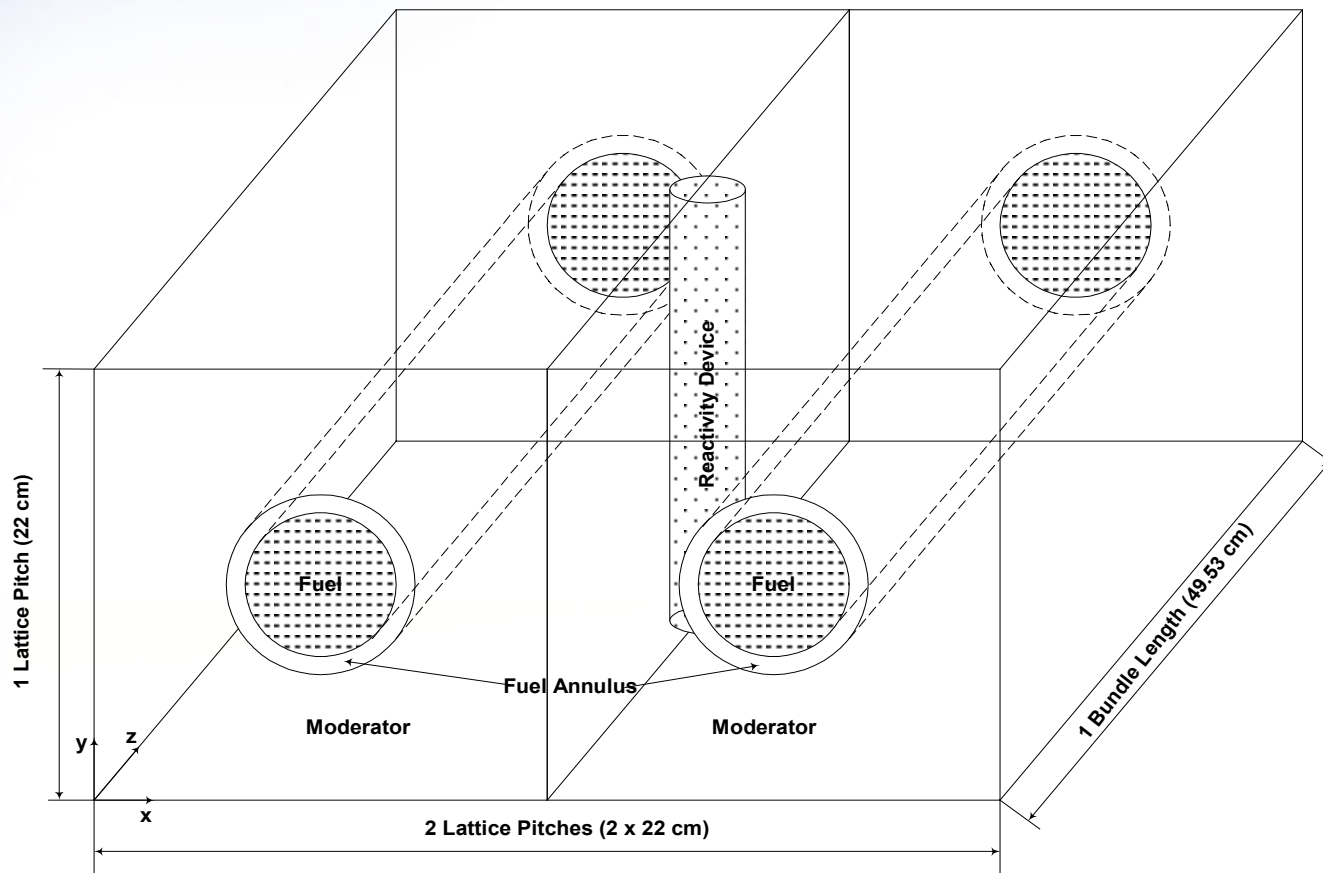

Boundary Conditions:

X_- Reflection	X_+ Symmetry
Y_- Reflection	Y_+ Symmetry
Z_- Reflection	Z_+ Symmetry



Reactivity-Device Code

DRAGON-IST

- **Calculates effect of reactivity device on lattice properties in vicinity**
- **Uses 3-d neutron transport theory**
- **Uses same ENDF-B/VI library as WIMS-AECL**
- **3-d capability is required because CANDU devices are perpendicular to fuel channels**
- **Device incremental cross sections are fed to core model and are added to basic lattice properties over modelled volume (supercell)**



Full-Core Code

RFSP-IST

- **Combines inputs from lattice and reactivity-device codes into a full-core model**
- **Calculates core reactivity, flux and power distributions**
- **Main solution scheme: 3-d, 2-group neutron-diffusion theory**
- **Steady-state and kinetics applications**
- **Can also do flux mapping**
- **A very large code (>1,500 subroutines), with large number of functionalities**



Monte-Carlo Code

MCNP

- **Not part of the IST suite of codes, but is increasingly used, mostly for benchmarking and for special applications or studies**
- **Used mostly for calculations at the lattice-cell level**
- **However, full-core applications have started to be made in the last year or two, and will certainly become more common in the future.**



Types of CANDU Core Analyses

Some types of full-core CANDU physics analyses:

- Calculation of steady-state flux distributions for various reactor configurations**
- Calculation of static reactivity worths of devices**
- The time-average equilibrium core**
- Core-follow simulations, with burnup steps and channel refuellings**
- Fuel-management simulations for various refuelling schemes**

cont'd



Types of CANDU Core Analyses

Some more types of full-core CANDU physics analyses:

- Simulation of “random” instantaneous core snapshots**
- Simulation of $^{135}\text{Xe}/^{135}\text{I}$ transients**
- Simulation of asymptotic bulk and spatial control**
- Calculation of harmonic flux shapes for use in flux mapping**
- Kinetics calculations to verify the performance of the shutdown systems**
- Coupled neutron-kinetics-thermalhydraulics calculations (e.g., Large-LOCA simulations)**
- Kinetics calculations coupled with simulation of RRS action**



Time-Average Model

- **In the time-average model of the reactor, the lattice cross sections at each point (fuel-bundle position) in the core are averaged over the residence time of the fuel at that location.**
- **This allows the effect of the actual refuelling scheme used (e.g. 8- bundle shift, 4- bundle shift, etc.) to be captured.**
- **Calculations are performed in the *TIME-AVER module of RFSP-IST.**
- **The time-average nuclear cross sections are defined at each bundle position by averaging the lattice cross sections over the irradiation range “experienced” over time by fuel at that position, i.e., from the value of irradiation when the fuel enters that position in core to the value when the fuel exits that position.**



Time-Average Model

- The time-average calculation requires consistency between the flux, the channel dwell times (interval between refuellings), the individual-bundle irradiation ranges, and the lattice properties. An iterative scheme of solution is employed until all quantities converge.
- Typically, in the time-average model, the core is subdivided into many irradiation regions (see next Figure).
- An average fuel exit irradiation is selected for each region, and the values are designed to achieve criticality and a desired degree of radial flattening of the flux shape.
- The exit irradiation values may have to be determined by several trials.
- The 2nd Figure following shows the iterative scheme for the time-average calculation.

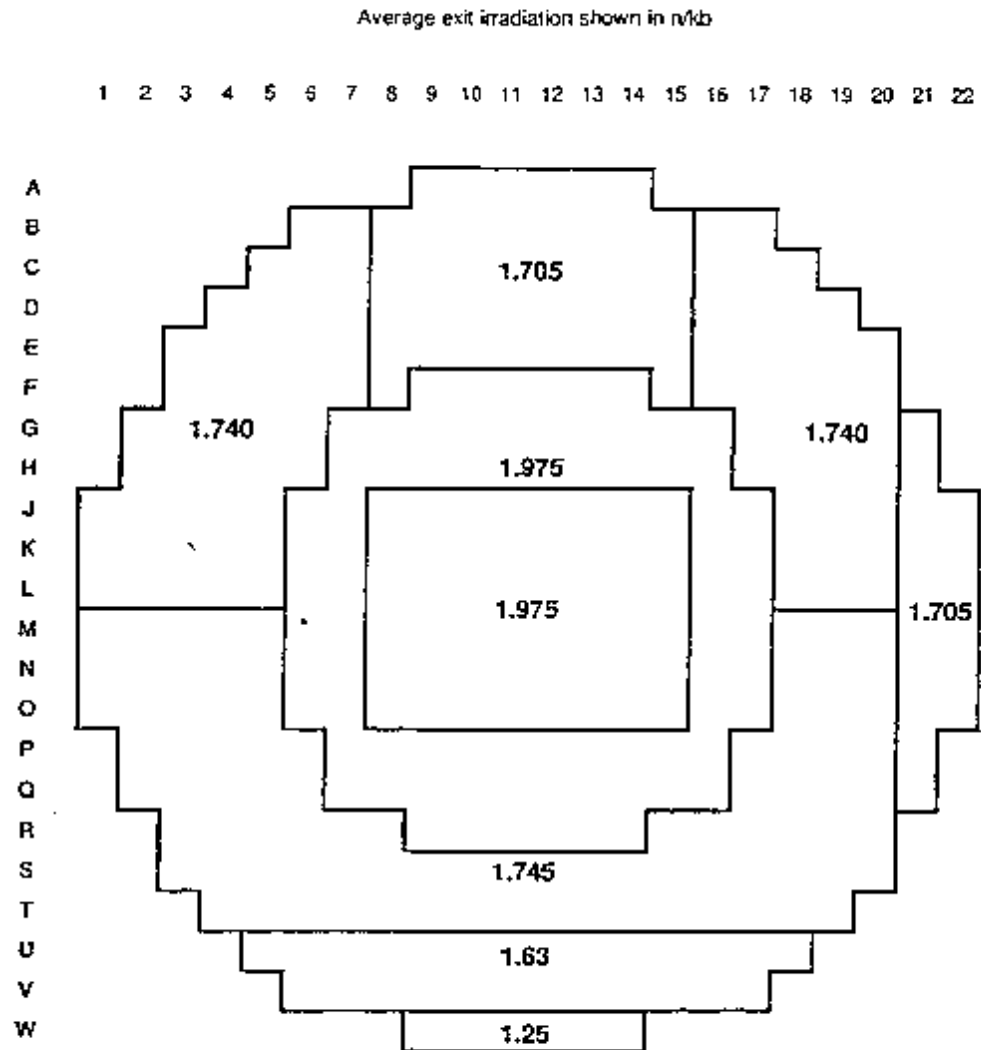

Multiple-Region Time-Average Model for CANDU₆

Time-Average Calculation



**Bundle Data Needed:
Axial Refuelling Scheme
Bundle Location in Channel
Exit Irradiation for Channel**

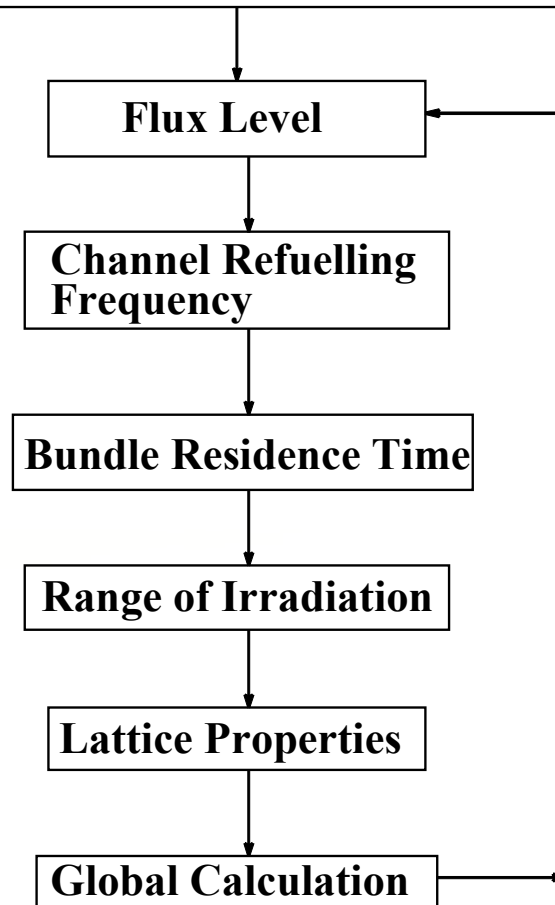

Calculational Scheme For Time-Average Calculation ^{Pg 63}



Time-Average Model

- The time-average model is useful at the design stage, to determine the reference 3-d power distribution, the design time intervals between refuellings of each channel (channel dwell times), and the expected values of discharge burnup for the various channels.
- For the CANDU 6:
 - The core-average fuel exit burnup is ~ 7500 MW.d/Mg(U)
 - The time-average channel powers range from about 6.6 MW in the inner core to about 3.0 MW at the core periphery.
 - Channel dwell times range typically from about 180 FPD in the inner core to about 350 FPD at the core periphery. The core-average value of dwell time is 206 FPD.



Time-Average Model

- **The CANDU reactor-physics design has a great number of “degrees of freedom”, which are the fuel exit irradiation (or burnup) values in individual channels (or, alternatively, the channel refuelling frequencies, related quantities)**
- **By varying the distribution of exit irradiations, the global time-average power distribution can be shaped almost at will.**
- **Other degrees of freedom are the axial refuelling schemes to be used in the various channels (which, again, need not all be the same).**
- **Once the time-average irradiation distribution is obtained, perturbations in the time-average core can be simulated, e.g., device movements and consequent reactivity changes (or worths) can be calculated. These results can be validated against measurements.**



Equilibrium (Time-Average) Core

- **A consequence of on-power refuelling is that the CANDU equilibrium core contains fuel at a range of burnups, from 0 to the average exit-burnup value.**
- **The average in-core burnup is fairly constant over time, at about half the exit value.**
- **The long-term global flux and power distributions in the equilibrium core can be considered as constant in time (given by the “time-average” shape), with instantaneous local “refuelling ripples” superimposed.**
- **These ripples are due to the various instantaneous values of fuel burnup in the different channels, and are the result on any given day of the specific sequence of channels refuelled in the previous days, weeks and months.**



Neutron Balance in Core

- It is instructive to look at a typical neutron balance in the CANDU-6 equilibrium core. See next Figure. (Note: this was calculated with a previous lattice code.)
- > 45% of fission neutrons originate from fissions in plutonium: Pu contributes ~ half the fission energy produced in a CANDU reactor. (Actually, near the exit burnup, Pu contributes about 3/4 of the fission energy.)
- Fast fissions account for 56 fission neutrons out of 1,000.
- Total neutron leakage is ~29 neutrons lost per 1000 born (6 from fast leakage, 23 from thermal leakage).
- Resonance absorption in ^{238}U represents a loss of almost 90 mk.
- Parasitic absorption in non-fuel components of the lattice represents a 63-mk loss.

Typical Neutron Balance in CANDU 6 (Time-Average Core)



PRODUCTION: Total 1000 n
491.9 n from U-235 Thermal Fission
438.4 n from Pu-239 Thermal Fission
13.2 n from Pu-241 Thermal Fission
56.5 n from U-238 Fast Fission

FAST LEAKAGE: 6.0 n

FAST ABSORPTION IN FUEL: 31.7 n

SLOWING DOWN

**RESONANCE ABSORPTION IN U-238:
89.4 n**

THERMAL LEAKAGE: 23.0 n

THERMAL ABSORPTION: 849.9 n

THERMAL ABSORPTION IN NON-FUEL CORE COMPONENTS: Total 63.4 n
6.2 n in Fuel Sheaths
19.0 n in Pressure Tube
8.5 n in Calandria Tube
14.4 n in Moderator
15.0 n in Adjusters, Zone Controllers and Other Tubes
0.3 n in Coolant

THERMAL ABSORPTION IN FUEL: Total 786.5 n
242.3 n in U-235
238.2 n in U-238
228.1 n in Pu-239
15.6 n in Pu-240
6.2 n in Pu-241
0.1 n in Pu-242
0.6 n in Np
55.4 n in Fission Products (of which 25.2 in Xe, 7.7 in Sm, 2.6 in Rh, 19.9 in others)



Fuel Management - k_{∞}

- The infinite-lattice multiplication constant k_{∞} can be calculated from the basic-lattice cross sections provided by the cell code, and applies to the “ideal” situation of an infinite array of identical cells.
- The k_{∞} is ~ 1.122 for fresh fuel (i.e., at zero burnup).
- After decreasing in the first few days as ^{135}Xe and other saturating fission products build in, the reactivity starts to increase with increasing burnup, reaching a maximum at $\sim 40\text{-}50$ FPD
- This is the natural-uranium-fuel “plutonium peak” (a peak in reactivity, not in plutonium concentration).
- Beyond the plutonium peak, the reactivity starts to decrease monotonically, on account of the continuing depletion of ^{235}U and the increasing fission-product load.



k-infinity for CANDU Lattice Fuelled with 37-Element Fuel

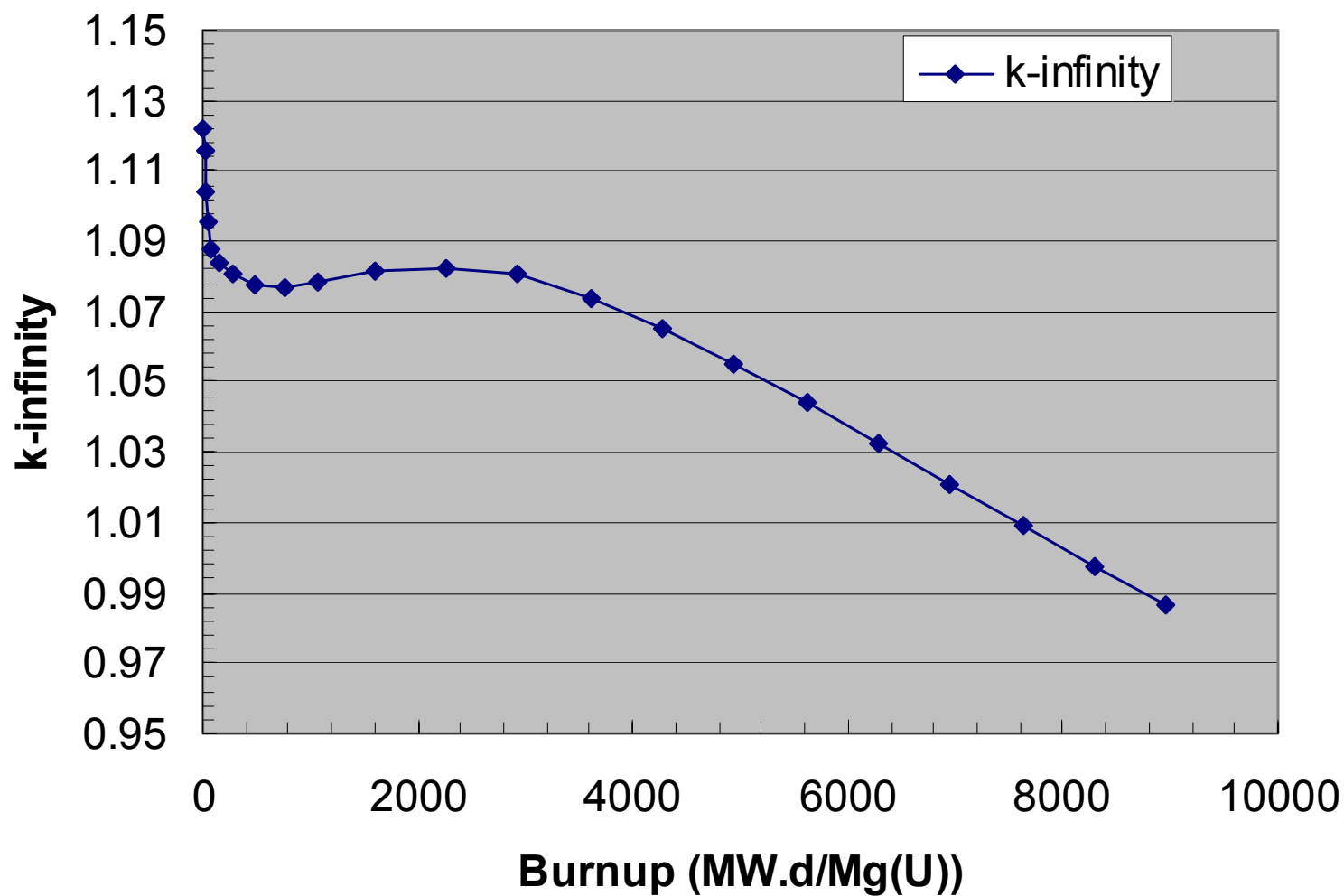



Initial Period of Reactor Operation

- On the very first startup of the reactor, all fuel is fresh.
- Thus the variation in reactivity of the finite reactor will mirror that of the infinite lattice (but the absolute reactivity is of course lower because of the in-core devices and the neutron leakage).
- The initial-core excess reactivity is compensated by the use of some depleted fuel and some moderator poison.
- 160 depleted-uranium bundles (0.52 atom%) are used in the CANDU 6: 2 bundles in each of 80 inner-core channels (see Figure). These help in achieving the axial flattening desired.
- In addition, ~ 2.2 ppm of B is needed at FPD 0.
- The entire core goes through a plutonium peak at ~ 40 -50 FPD. This is compensated by changes in B.
- When the B reduces to near 0 (close to 100 FPD, see Figure), refuelling starts.

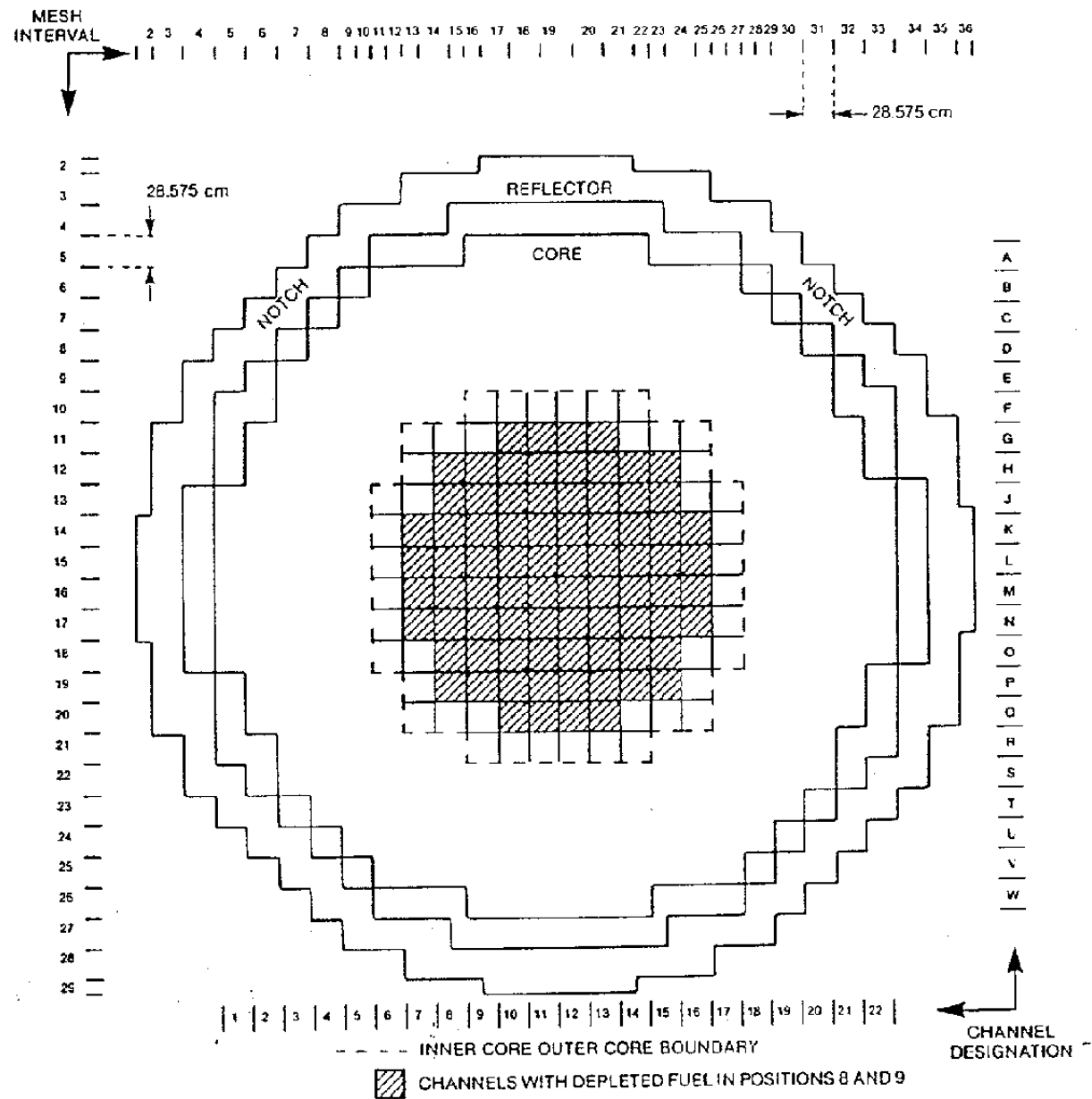

Channels with Depleted Fuel in Initial Core of CANDU 6

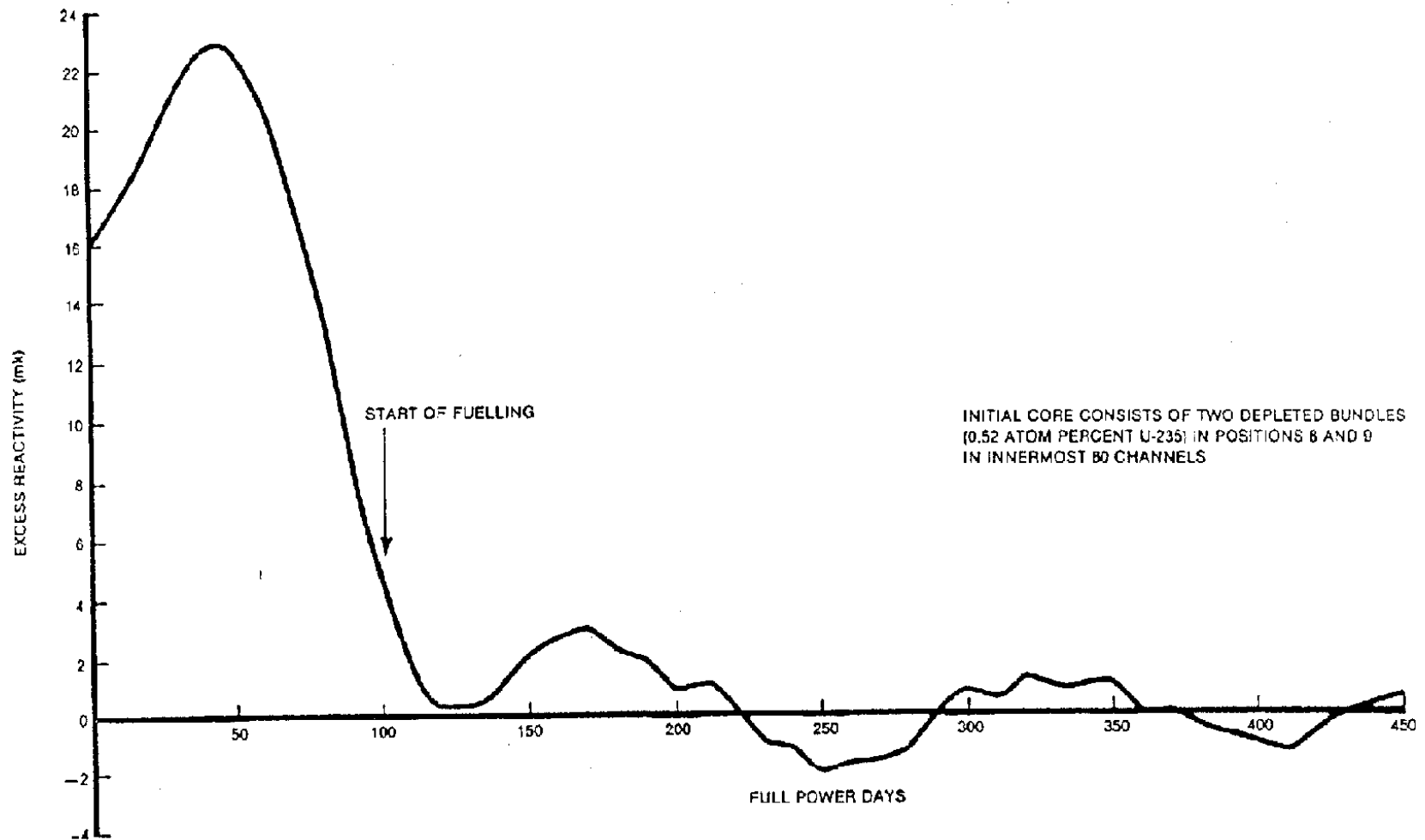

Typical Excess Core Reactivity in Initial Period of Reactor Operation



Channel Refuellings

- A main function of the fuel engineer is to establish a list of channels to be refuelled during the following few days of operation.
- To achieve this, the current status of the reactor core is determined from RFSP-IST simulations, from the on-line flux mapping system, the ROP and RRS in-core detector readings, and zone-control-compartment water fills.
- RFSP-IST provides the instantaneous 3-dimensional flux, power and burnup distributions.
- First, channels which are poor candidates for refuelling are eliminated.
- Then a selection of good candidates is made, with the aim of maximizing burnup, maintaining the overall core power distribution, achieving symmetry, etc.



Channel-Power Cycle

- When a channel is refuelled, its local reactivity is high; its power will be several percent higher than its time-average power.
- The fresh fuel in the channel then goes through its plutonium peak as it picks up burnup, and the power of the channel increases further. The higher local reactivity promotes a power increase in neighbouring channels.
- Following the plutonium peak, the reactivity of the refuelled channel decreases, and its power drops slowly. About half-way through the dwell time, the power of the channel may be close to the time-average value.
- The reactivity of the channel and its power continue to drop. The channel becomes a net “sink” or absorber of neutrons, and eventually the channel must be refuelled.
- At this time the power of the channel may be 10% or more below its time-average power. When the channel is refuelled, its power may jump by 15 to 20% or even more.



Channel-Power Cycle

- The power of each channel goes through an “oscillation” about the time-average power during every cycle.
- The cycle length is not exactly equal to the dwell time, because channels are not refuelled in a rigorously predetermined sequence.
- In addition, the CANDU fuelling engineer has flexibility in deciding how the core should be managed, and in fact can decide to modify the global power distribution by changing the refuelling frequency of various channels.
- As individual channels are refuelled, the specific sequence results in variability in the instantaneous peak channel and bundle powers in the core.
- Next Figure shows a schematic plot of the maximum channel power versus time, and illustrates difference between maximum time-average channel power, average maximum instantaneous channel power, and absolute maximum channel power.

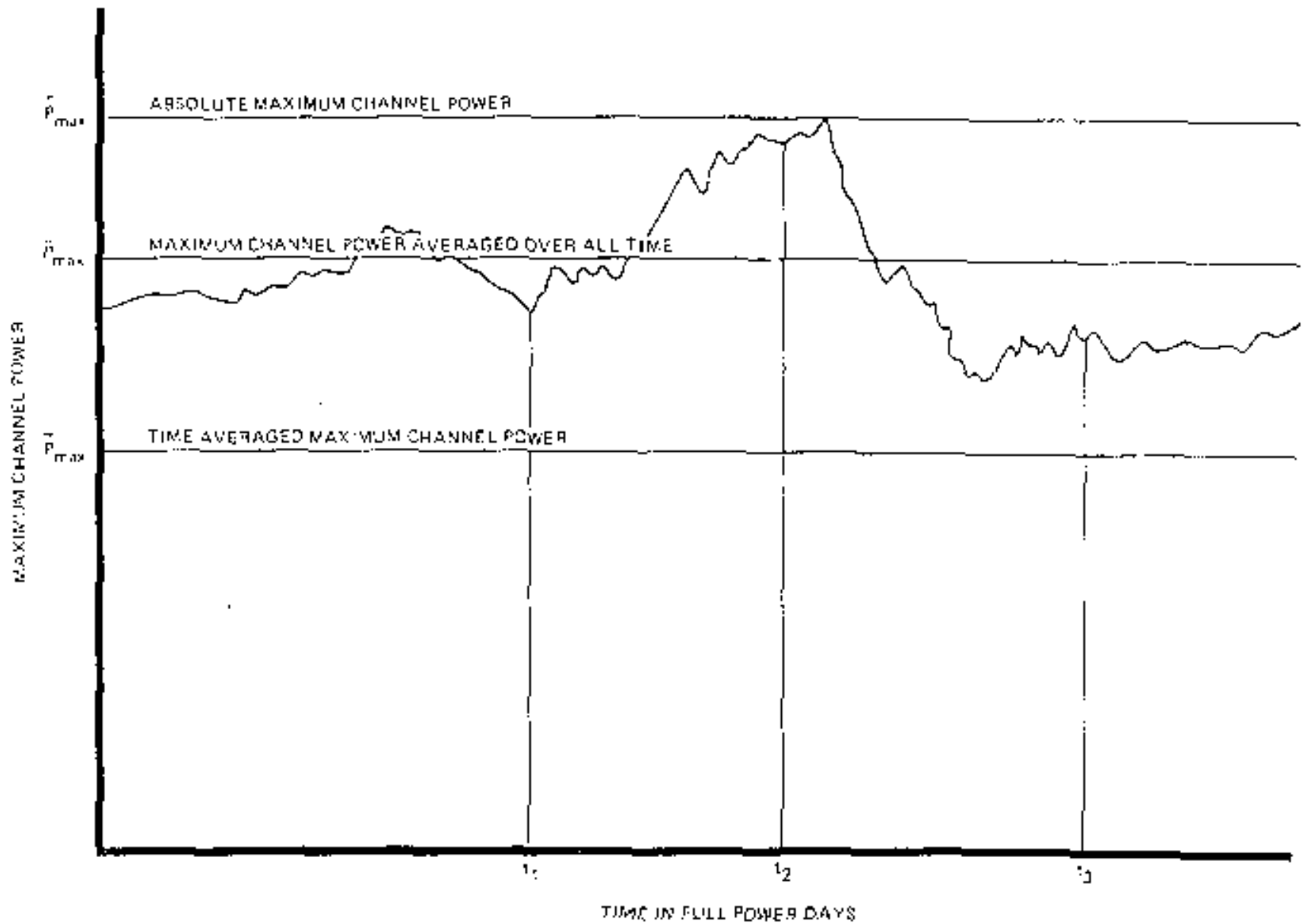

Schematic of Maximum Channel Power versus Time



Core-Follow Calculations with RFSP-IST

- **Main application of RFSP-IST at CANDU sites is in core-follow.**
- **The core history is tracked with *SIMULATE module as a series of instantaneous snapshots, typically in steps of 2-3 FPD.**
- **The code accounts for channel refuellings as they occur, as well as changes in zone-control-compartment fills, concentration of moderator poison, and other device movements.**
- **The effect of the ^{135}Xe distribution is also taken into account.**
- **Bulk and spatial control can be modelled if desired.**
- **Validation of the calculation is done against in-core detector readings; typical standard deviation of differences between calculated and measured detector fluxes $\sim 2.5\%$.**
- **Core tracking can also be done with the flux-mapping method, using the detector readings.**



Local-Parameter History-Based Calculations

- **Core-follow** is a good example of analysis where local-parameter history-based calculations are exercised.
- While fuel burnup is the most important parameter in determining lattice properties, other parameters which may vary spatially in the core (e.g., fuel temperature, coolant density, flux level) or which may change with time (e.g., moderator-poison concentration) are also important.
- In local-parameter history-based calculations, lattice properties are computed separately for each fuel bundle in core, and are not simply interpolated in a table as a functions of fuel burnup, but are obtained for the specific local conditions in the lattice.



^{135}Xe Effects

- **The ^{135}Xe - ^{135}I kinetics are taken into account in calculations of:**
 - **the steady-state ^{135}Xe reactivity load at full power (~28 mk)**
 - **the effect on the 3-d power distribution in the core: the larger ^{135}Xe in high-power bundles reduces the peak bundle and channel powers by a few percent.**
 - **transient effects on reactivity and power shape following power maneuvers and movements of reactivity devices (e.g., a power recovery after a short shutdown, with adjuster movements to counter the changes in ^{135}Xe and maintain criticality).**



^{135}Xe Effects

- **The effect of the initial absence, and subsequent build-up, of ^{135}Xe (and other saturating fission products) in new fuel bundles can also be modelled, if a detailed simulation is performed of the period following a channel refuelling, with time steps of hours instead of days.**
- **Modelling of ^{135}Xe effects together with bulk and spatial control can also show how the Reactor Regulating System dampens possible ^{135}Xe oscillations.**



CANDU Positive Void Reactivity

Simple explanation of major causes – 3 positive, 1 negative (refer to Figure of Basic Lattice Cell):

- **Increase in fast-fission factor (when the coolant is absent, fewer fission neutrons are slowed down within the fuel cluster itself)**
- **Also, since fewer neutrons are slowed down in fuel cluster to energies in the resonance range, more neutrons escape resonance absorption before entering moderator**
- **Most neutrons re-entering fuel cluster from moderator are thermal neutrons. Hot coolant promotes some to higher energies (by collision), leading to some resonance absorption. Without coolant, this effect is absent, and there is increased resonance-absorption escape.**

Cont'd



CANDU Positive Void Reactivity

Simple explanation of major causes – 3 positive, 1 negative (refer to Figure of Basic Lattice Cell):

- **For irradiated fuel, with plutonium, there is a negative component in reactivity change, due to a reduction in fissions from the low-lying (0.3 eV) fission resonance. The net void reactivity is still positive (but smaller than for fresh fuel).**
- **Full-core void reactivity can range from 10 to 15 or more mk, depending on core burnup and other parameters. Of course, it is not physically possible to lose all coolant from the core instantaneously.**
- **However a Large Loss of Coolant is a hypothetical accident which must be analyzed.**



Large LOCA

- **A large loss of coolant is a hypothetical accident which presents the greatest rate of positive reactivity insertion.**
- **Large LOCA is caused by the rupture of a large pipe, e.g. RIH, ROH, or Pump-Suction pipe (see next Figure).**
- **In CANDU 6, a Large LOCA can inject 4-5 mk in the first second after the break, which is beyond the capability of the Reactor Regulating System to control.**
- **This leads to a power pulse which is terminated by a SDS.**



Examples of Break Locations for a Large LOCA

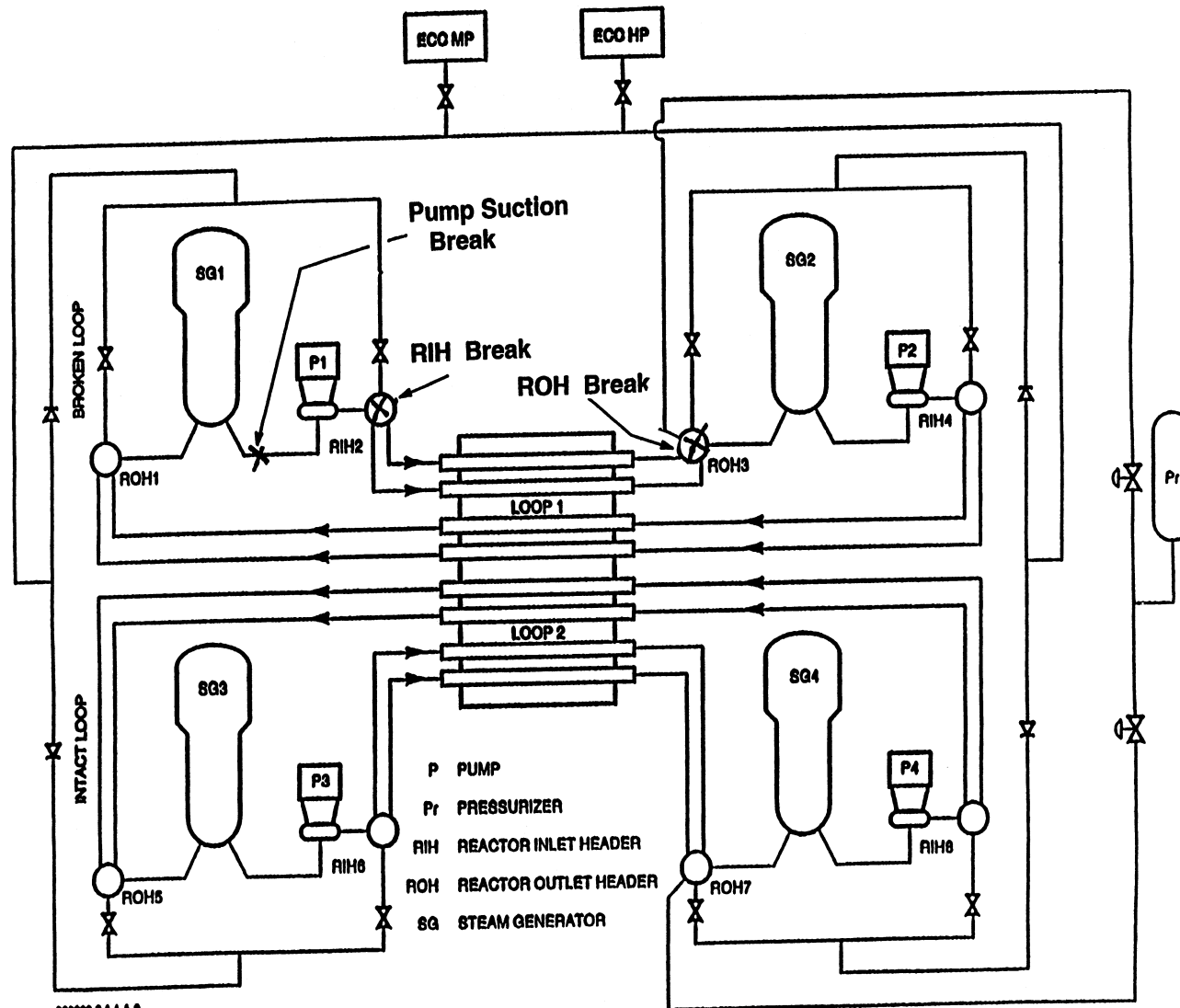

930063-2.1.1.A-2



Large LOCA – Kinetics Calculation

- **The LOCA is analyzed with *CERBERUS, the spatial-kinetics module of RFSP-IST.**
- ***CERBERUS uses the Improved Quasistatic (IQS) method to calculate the neutron flux as a function of time.**
- **The 3-d flux is factorized into a space-and-time-dependent shape function and an amplitude which is a function of time only.**
- **Most of the time variation is cast into the amplitude, which can easily be calculated over very small time steps (ms)**
- **This allows the onerous shape-function calculation to proceed over larger time steps (~50-100 ms), normally chosen according to the time intervals it takes for SORs to drop by one lattice pitch, or poison front to advance by one lattice pitch.**



Large LOCA

- A thermalhydraulics calculation (e.g., with the CATHENA code) provides the coolant-density transient in space and time, as follows.
- The thermalhydraulics model subdivides the fuel channels into a number (8-20) of “groups” by loop, by power region, and by position in core (see next slide).
- The thermalhydraulics code obtains the coolant density for each bundle position in each channel group.
- Iterations are performed to achieve consistency between the initial power and coolant-density distributions.
- The LOCA transient is then advanced as alternate, coupled thermalhydraulics and kinetics calculations over the shape-function time steps.
- LOCA simulation is another example of a local-parameter calculation, since coolant density is highly dependent on space and time.



Typical Thermalhydraulics Channel Grouping for LOCA

NOTE: Numbers in boxes indicate the channel group number

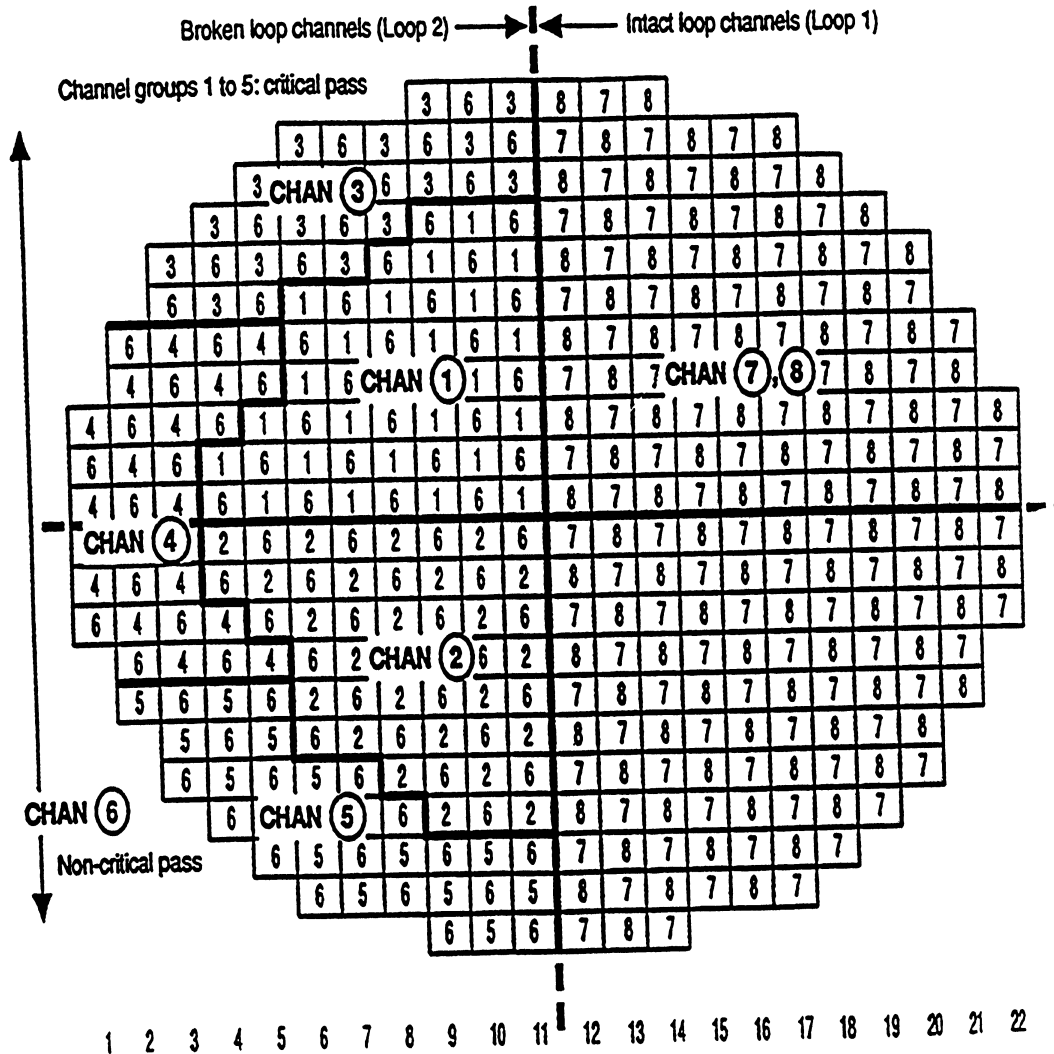



Large LOCA

- **The calculation of the LOCA transient also requires the computation of the SDS actuation time, which relies on the modelling of:**
 - **the response of ion chambers and of in-core detectors (including the delayed parts of the response)**
 - **the electronic components (relays, amplifiers, compensators) of the instrumentation**
 - **the detector setpoints and the triplicated trip logic**
 - **the speed of action of the SDS (i.e., SOR drop, poison-front advance)**
- **The next 2 slides show some typical density transients and power pulses which may be obtained from a Large-LOCA calculation.**



Examples of Coolant Densities Calculated for Various Channel Groups

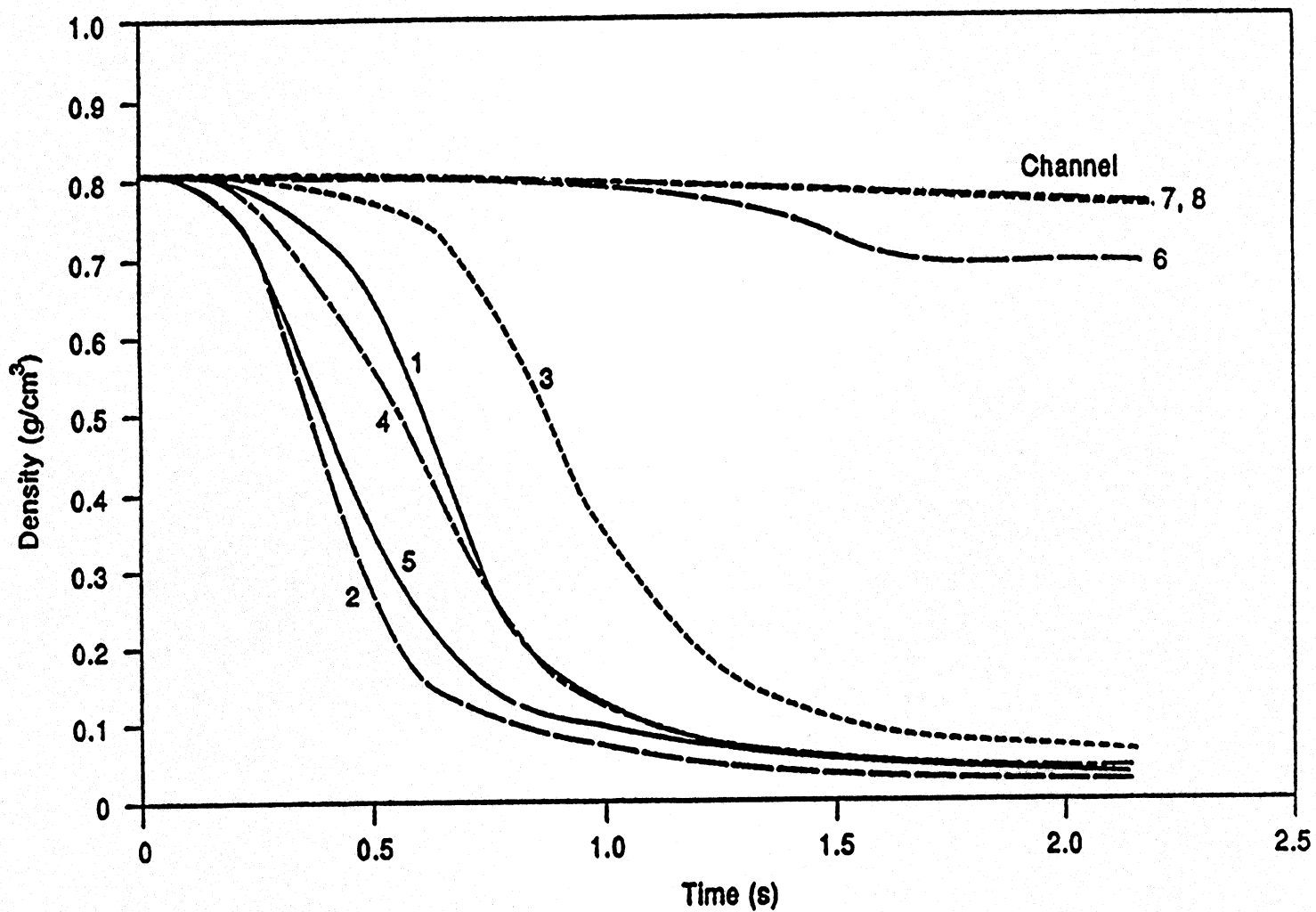

Typical Power Pulses in CANDU 6 for Individual Bundle and for Broken- & Intact-Loop Core Halves

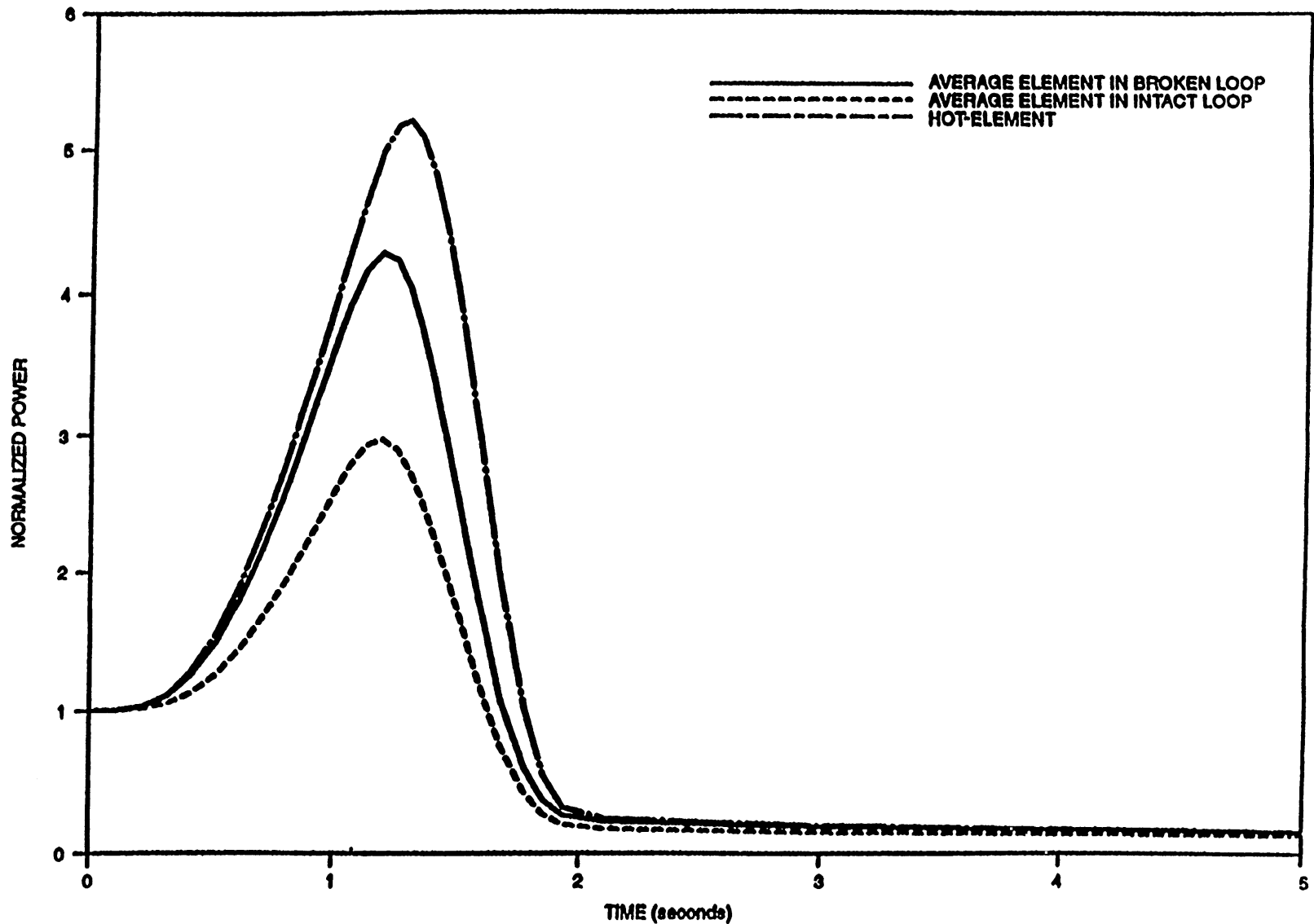



***CERBERUS Validation**

- **The IQS kinetics calculations performed in the *CERBERUS module have been validated numerous times against shutdown-system tests at operating reactors, with excellent results.**
- **SDS commissioning tests also serve as a means of validation of shutdown-system action, detector and electronics modelling, and delayed-neutron parameters.**



Summary

- **The reactor physics of the current CANDU plant is analyzed with a 3-component suite of physics Industry Standard Tools: lattice, device, and full-core computer codes.**
- **These IST codes have extensive capabilities and can model and analyze essentially all situations of interest in CANDU reactor physics.**
- **Extensive validation of the code suite for physics phenomena at play in the standard CANDU has been carried out.**



 **AECL**
TECHNOLOGIES INC.