

1.2 General Plant Description

This section includes a general discussion of the objectives, design criteria, operating characteristics and safety considerations for the AP600 and provides a general description of the plant site, the site criteria, the general plant arrangement, the plant arrangement criteria and key features of each of the individual buildings that are collectively defined as the power generation complex.

Design Certification is sought for the power generation complex, excluding those elements and features considered site-specific. The AP600 design extends beyond those structures, systems, and equipment which are safety-related. All safety-related structures, systems, and components are located on the nuclear island and are to be included in the design certification. To provide a better understanding of the safety-related features of the AP600, nonsafety-related features are also described in this DCD. In addition, some plant design features which are outside the boundary of the AP600, and considered to be site-specific, are described for completeness and to provide a basis for quantification of the required interfaces, as required by 10 CFR 52.47 (a)(1)(ix). The site-specific structures located off the nuclear island are neither safety-related nor seismic Category I. A more complete description of interfaces for the standard design is contained in Section 1.8.

1.2.1 Design Criteria, Operating Characteristics, and Safety Considerations

This section provides an overview of the AP600 design objectives, design criteria, operating characteristics and safety considerations.

1.2.1.1 Overall Plant

The primary objective of the AP600 design is to meet applicable safety requirements and goals defined for advanced light water pressurized water reactors with passive safety features. Westinghouse was a principal participant in the development of the EPRI sponsored Utility Requirements Document (URD) and continues to be involved with EPRI on changes to that document. Therefore, the AP600 design remains consistent with the EPRI URD. Additional design objectives for the AP600 are to provide a greatly simplified plant with respect to design, licensing, construction, operation, inspection and maintenance. Specific design objectives follow.

1.2.1.1.1 Power Capability Objectives

- The plant's net electrical power to the grid is at least 600 MWe with a nuclear steam supply system power rating (core plus reactor coolant pump heat) of 1940 MWt.
- The plant is designed for rated performance with up to 10 percent of the steam generator tubes plugged and with a maximum hot leg temperature of 600°F.

- The plant is designed to accept a step load increase or decrease of 10 percent between 25 and 100 percent power without reactor trip or steam dump system actuation provided the rated power level is not exceeded.
- The plant is designed to accept a 100 percent load rejection from full power to house loads without reactor trip or operation of the pressurizer or steam generator safety valves. The design provides for a turbine capable of continued stable operation at house loads.
- The plant is designed to accept ramp load changes of 5 percent per minute while operating in the range of 25 to 100 percent of full power without reactor trip or steam dump actuation subject to core power distribution limits and provided the rated power level is not exceeded.
- The plant is designed to permit a design basis daily load follow cycle for at least 90 percent of the fuel cycle length. The design basis daily load follow cycle is defined as the daily (24 hour period) cycle of operation at 100 percent power, followed by a 2-hour linear ramp to 50 percent power, operation at 50 percent power and a 2-hour linear ramp back to 100 percent power. The duration of time at 50 percent power can vary between 2 and 10 hours. This load follow capability is achievable during 90 percent of each fuel cycle.
- During load follow the plant is designed to routinely make load changes of ≤ 10 percent at ± 2 percent per minute between 50 and 100 percent power without exceeding the core power distribution limits for the purpose of responding to grid frequency changes. No change to the reactor coolant boron concentration is required during these load follow maneuvers.

1.2.1.1.2 Reliability and Availability Objectives

- The overall plant availability goal is greater than 90 percent considering all forced and planned outages.
- The rate of unplanned reactor trips goal is less than one per year.
- The plant is designed with significantly fewer components and significantly fewer safety-related components than a current pressurized water reactor of a comparable size.
- The plant design objective is 60 years without the planned replacement of the reactor vessel which itself has a 60 year design objective based on conservative assumptions. The design provides for the replaceability of other major components, including the steam generators.
- The design of the major components required for power generation such as the steam generators, reactor coolant pumps, fuel, internals, turbine and generator is based on equipment that has successfully operated in power plants. Modifications to these proven

designs were based on similar equipment that had successful operating experience in similar or more severe conditions.

1.2.1.1.3 Safety Design Criteria

- The plant design conforms to applicable regulations as discussed in Sections 1.9 and 3.1.
- The plant is designed to be fabricated, erected, and operated in such a manner that the release of radioactive materials to the environment does not exceed the limits and guideline values of applicable government regulations pertaining to the release of radioactive materials for normal operations and for design basis transients and accidents.
- Gaseous and liquid waste disposal facilities are designed so that the discharge of radioactive effluents can be made in accordance with applicable regulations.
- The design provides means by which plant operators are alerted when limits on the release of radioactive effluent are approached.
- The reactor core is designed so its nuclear characteristics do not contribute to a divergent power transient.
- The reactor is designed so that there is no tendency for divergent oscillation of any operating characteristic, considering the interaction of the reactor with other appropriate plant systems.
- Sufficient indications are provided to allow determination that the reactor is operating within the envelope of conditions considered by plant safety analysis.
- Essential safety actions are provided by equipment of sufficient redundancy and independence so that no single failure of active components can prevent the required actions.
- Provisions are made for control of active components of nuclear safety systems and engineered safety features from the control room.
- Those portions of the nuclear steam supply system that form part of the reactor coolant pressure boundary are designed to retain integrity as a radioactive material containment barrier following design basis operational transients and accidents.
- Nuclear safety systems and engineered safety features functions are designed so that no damage to the reactor coolant pressure boundary results from internal pressures caused by design basis operational transients and accidents.
- Nuclear safety systems and engineered safety features are designed to permit demonstrations of their functional performance requirements.

- The design of nuclear safety systems and engineered safety features includes allowances for natural environmental disturbances such as earthquakes, floods, and storms at the station site.
- Standby electrical power sources have sufficient capacity to power the nuclear safety systems and engineered safety features requiring electrical power. Safety-related electrical power requirements needed during a loss of offsite power are supplied via Class 1E dc power.
- Standby electrical power sources are provided to allow prompt reactor shutdown and removal of decay heat under circumstances where normal auxiliary power is not available.
- A containment is provided which completely encloses the reactor system.
- The containment is designed to allow periodic integrity and leak tightness testing.
- The containment, in conjunction with other engineered safety features, limits the release of radioactivity from inside the containment, in the event of a design basis accident. This has the effect of limiting radiological consequences of a design basis accident to within an appropriate fraction of regulatory guidelines.
- Piping that penetrates the containment and could serve as a path for the uncontrolled release of radioactive material to the environs is automatically isolated whenever such uncontrolled radioactive material release is threatened. Such isolation is effected in time to limit radiological effects to less than the specified acceptable limits.
- Provisions are made for passively removing energy from the containment to maintain the integrity of the containment system following accidents that release energy to the containment.
- Passive core cooling systems are provided to limit fuel cladding temperature to less than the limits established by 10 CFR 50.46 in the event of a loss-of-coolant accident.
- The passive core cooling system provides for core cooling over the complete range of postulated break sizes in the reactor coolant pressure boundary.
- Actuation of the passive core cooling system occurs automatically when required, regardless of the availability of offsite power supplies and the normal generating system.
- The control room is shielded against radiation so that continued occupancy under accident conditions is possible.

- In the event that the control room becomes uninhabitable, it is possible to bring the reactor from power range operation to safe shutdown conditions by utilizing the remote shutdown workstation located outside the control room.
- Backup reactor shutdown capability is provided independent of normal reactivity control provisions. This backup system has the capability to shutdown the reactor from any normal operating conditions and subsequently to maintain the shutdown condition.
- The fuel handling and storage facility is designed to prevent inadvertent criticality and to maintain shielding and cooling of spent fuel.

1.2.1.1.4 Site Objectives

- The plant is designed for location at a site with the parameters set forth in Chapter 2, Site Characteristics.

1.2.1.1.5 Other Objectives

- The radiation exposure goal for plant personnel resulting from normal operation, inspection and maintenance is less than 100 man-Rem/year. Radiation shielding is provided and access control patterns are established to allow a properly trained operating staff to control radiation doses within the limits of applicable regulations in any mode of normal plant operations.
- The total low level radioactive waste volume goal is less than 1,750 cubic feet per year after de-watering. This waste includes items such as spent resins, spent filter elements, tank sludge, chemical wastes, and clothing. Spent condensate polishing resins are not included. The total wet radioactive waste volume produced from spent resin and filter elements, tank sludge and chemical waste is designed not to exceed 450 cubic feet per year (de-watered).

1.2.1.2 Reactor Coolant System Design

The AP600 reactor coolant system (Figure 1.2-1) is designed to remove or to enable removal of heat from the reactor during all modes of operation, including shutdown and accident conditions.

The system consists of two heat transfer circuits, each with a steam generator, two reactor coolant pumps, a single hot leg and two cold legs, for circulating reactor coolant. In addition the system includes a pressurizer, interconnecting piping, valves and instrumentation necessary for operational control and safeguards actuation. All system equipment is located in the reactor containment.

During operation, the reactor coolant pumps circulate pressurized water through the reactor vessel and the steam generators. The water, which serves as coolant, moderator and solvent

for boric acid (chemical shim control), is heated as it passes through the core to the steam generators where the heat is transferred to the steam system. The water is then returned to the reactor (core) by the pumps to repeat the process.

The reactor coolant system pressure is controlled by operation of the pressurizer, where water and steam are maintained in equilibrium by the activation of electrical heaters and/or a water spray. Steam is formed by the heaters or condensed by the water spray to control pressure variations due to expansion and contraction of the reactor coolant.

Overpressure protection for the reactor coolant system is provided by the spring loaded safety valves installed on the pressurizer. These valves discharge to the containment atmosphere. The valves for the first three stages of automatic depressurization are also mounted on the pressurizer. These valves discharge steam through spargers to the in-containment refueling water storage tank. The discharged steam is condensed and cooled by mixing with water in the tank.

The reactor coolant system is also served by a number of auxiliary systems, including the chemical and volume control system, the passive core cooling system, the spent fuel pit cooling system, the steam generator system, the primary sampling system, the liquid radwaste system and the component cooling water system.

1.2.1.2.1 Reactor Design

- The core is designed for a 24-month fuel cycle. The core is capable of operating on an 18-month fuel cycle.
- There are no reactor vessel penetrations below the top of the core.
- The core is designed for a moderator temperature coefficient that is non-positive over the entire fuel cycle and at any power level with the reactor coolant at the normal operating temperature.
- A three-region core design is maintained for projected fuel cycles.
- The core design provides adequate margin so that departure from nucleate boiling will not occur with a 95 percent probability and 95 percent confidence basis for all Condition I and II events.
- A radial neutron reflector is used in the reactor design.
- The vessel design objective is 60 years with less than 2×10^{19} neutrons per square centimeter ($E > 1.0$ MeV) fast neutron fluence.
- The core is located low in the vessel to minimize core temperature during loss-of-coolant accidents.

- The vessel and internals are designed so coolant at approximately the average of T_{cold} and T_{hot} is maintained in the head and control rod drive mechanism regions.
- The lower internals are designed to prevent flow jetting from the reflector into the core.
- Bottom mounted incore instrumentation is not used. No vessel penetrations exist below the top of the core.
- An integrated head package which contains the control rod drive mechanisms, integrated head cooling fans, instrument columns, insulation, seismic support and package lift rig is employed.
- A permanent welded seal ring is used to provide the seal between the vessel flange and the refueling cavity floor.

1.2.1.2.2 Steam Generator Design

- The Model Delta 75 steam generator of proven design is employed. The steam generator employs thermally treated nickel-chromium-iron Alloy 690 tubes and a steam separator area sludge trap with clean out provisions.
- The channel head is designed for the direct attachment of two reactor coolant pumps.
- The channel head is designed for both manual and robotic accessibility for inspection, plugging, sleeving and nozzle dam placement operations.

1.2.1.2.3 Reactor Coolant Pump Design

- Hermetically sealed canned pumps of proven design are employed.
- Two reactor coolant pumps are attached directly to each steam generator channel head with the motor located below the channel head to simplify the loop piping and eliminate fuel uncover during small loss-of-coolant accidents.
- Each reactor coolant pump includes sufficient internal rotating inertia to provide a flow coastdown to avoid departure from nucleate boiling following a loss of reactor coolant flow accident.
- Each reactor coolant pump impeller and diffuser vanes are ground and polished to minimize radioactive crud deposition and to maximize pump efficiency.
- The reactor coolant pump motors are designed with appropriate lifting and handling attachments (lugs and trunnions) to facilitate maintenance.

- The reactor coolant pumps are designed such that they are not damaged due to a loss of all cooling water for ten minutes. Automatic protection is provided to protect the reactor coolant pumps from an extended loss of coolant water.

1.2.1.2.4 Pressurizer and Loop Arrangement

- The piping layout is designed for adequate thermal expansion flexibility assuming a fixed vessel and a free floating steam generator/reactor coolant pump support system.
- The reactor coolant loop and surge line piping are designed to leak-before-break criteria.
- The pressurizer is designed such that, with design spray flow rates, the power-operated relief valve function is not required nor provided.

1.2.1.3 Steam and Power Conversion System Design

1.2.1.3.1 Turbine Design

- The turbine is a power conversion system designed to change the thermal energy of the steam flowing through the turbine into rotational mechanical work which rotates a generator to provide electrical power. It consists of a double flow high pressure cylinder (high pressure turbine) and two double flow low pressure cylinders (low pressure turbines) which exhaust to the condenser. It is a four flow tandem compound, 1800 rpm machine. The turbine system includes stop, control and intercept valves directly attached to the turbine and in the steam flow path, crossover and crossunder piping between the turbine cylinders and the moisture separator reheater.
- The high pressure turbine has extraction connections for two stages of feedwater heating. The high pressure turbine exhaust steam provides steam for one stage of feedwater heating in the deaerator. The low pressure turbines have extraction connections for four stages of feedwater heating.
- The moisture separator reheater is an integral component of the turbine system which extracts moisture from the steam and reheats the steam to improve the turbine system performance. There is one moisture separator reheater located between the high pressure turbine exhaust and the low pressure turbine inlet. The reheater has a single stage of reheat.
- The turbine orientation minimizes potential interaction between turbine missiles and safety-related structures and components.

1.2.1.3.2 Main Steam System Design

- The main steam system is designed to supply steam from the steam generators to the high pressure turbine over a range of flows and pressures for the entire plant operating range, i.e., from system warmup to valves-wide-open turbine conditions.
- The main steam system is also designed to dissipate heat generated by the nuclear steam supply system to the condenser through steam dump valves or to the atmosphere through power-operated atmospheric relief valves or spring-loaded main steam safety valves when either the turbine-generator or the condenser is not available.
- Three steam generator safety valves are utilized per steam header. There are two steam headers.

1.2.1.3.3 Main Feedwater and Condensate System Design

- The main feedwater system is designed to supply the steam generators with adequate feedwater during all modes of plant operation including transient conditions. The condensate system is designed to condense and collect steam from the low-pressure turbines and turbine steam bypass systems and then, transfer this condensate from the main condenser to the deaerator.
- The main feedwater and condensate systems are designed for increased availability and improved dissolved oxygen control.
- A deaerating heater is employed.

1.2.1.4 Auxiliary Fluid Systems Design

1.2.1.4.1 Engineered Safeguards Systems Design

- The safety systems are designed to mitigate design basis accidents with a single failure, as defined in Chapter 15.
- The safety systems are designed to maximize the use of natural driving forces such as pressurized nitrogen, gravity flow and natural circulation flow. They do not use active components such as pumps, fans or diesel generators. A minimum number of valves are used for the purpose of initially aligning the safety systems.
- The safety systems are designed to function without safety-related support systems such as alternating current, component cooling water, service water, heating, ventilation and air conditioning.

- The number and complexity of operator actions required to control the safety systems are minimized. In meeting this objective, the approach was to eliminate the required action and not to automate them.
- An automatic reactor coolant system depressurization feature is included in the design and meets the following criteria:
 - The reliability (redundancy and diversity) of the automatic depressurization system valves and controls satisfies single failure criteria as well as the failure tolerance required by the low core melt frequency goals.
 - The design provides for both real demands (such as reactor coolant system leaks and failure of the chemical and volume control system makeup pumps) and spurious instrumentation signals. The probability of significant flooding of the containment due to the use of the automatic depressurization system is less than once in 600 years.
- The design is such that, for small break loss-of-coolant accidents up to 8 inches in diameter, the core remains covered.
- The passive safety-related systems can operate for at least 1 hour following anticipated transients without release of contaminants that require significant plant cleanup. The automatic depressurization system is designed not to activate for anticipated transients.
- The passive safety-related systems are designed to cool the reactor coolant system from normal operating temperatures to safe shutdown conditions.
- Containment heat removal design
 - Without replenishing passive containment cooling system water after the initial 7 day inventory is exhausted, the containment pressure remains below design pressure following a design basis accident.
 - With only air cooling, the containment pressure does not exceed its ultimate pressure during core melt scenarios.

1.2.1.4.2 Nonsafety-Related Systems Designs

- The nonsafety-related systems designs are simplified; the number of systems and components and the complexity of operation and maintenance are reduced from current operating plants.
- The nonsafety-related systems are not relied upon to provide safety functions required to mitigate design basis accidents.

- Nonsafety-related systems that are required for normal plant operation provide high plant availability. These systems have appropriate redundancy, are powered by onsite standby power supplies and have sufficient capacity to prevent automatic passive safety system actuation following anticipated Condition II events.
 - The reactor coolant system makeup capability design is sufficient for reactor coolant leaks up to 3/8 inch.
 - Steam generator feedwater capability from the startup feedwater system is designed to provide sufficient flow for a loss of main feedwater event.
 - The normal containment sump pumps (part of the radioactive waste drain system) are designed to assist in recovery from leakage to the containment sump.
- Boric acid solutions are designed to be stored at concentrations that do not require heat tracing or room temperatures above normal values.

1.2.1.5 Electrical and Control Systems Designs

1.2.1.5.1 Control and Protection Systems Designs

- The design provides that during normal operation, a single failure in the protection and safety monitoring system does not result in a reactor trip or engineered safety features actuation. For the reactor trip function this is true even with a channel under maintenance or test.
- The potential for reactor trip and for safeguards actuation due to failures in the plant control system is reduced relative to current operating plants.
- The number of measured plant variables used for reactor trip and for safeguards actuation is minimized relative to current operating plants.
- The margin between the normal operating conditions and the protection system setpoints is increased relative to current operating plants.
- The potential for interaction between the protection and safety monitoring system and the plant control system is reduced relative to current operating plants by incorporating a signal selector function that selects signals for control and for protection.
- A distributed logic system utilizing multiplexing techniques is used to significantly reduce the amount of wiring required in the plant.

1.2.1.5.2 Alternating Current and Direct Current Power Design

- Safety-related direct current (dc) power is provided to support reactor trip and engineered safeguards actuation. Batteries are sized to provide the necessary dc power and uninterruptible ac power for items such as the protection and safety monitoring system actuation, the control room functions including habitability, dc-powered valves in the passive safety-related systems and containment isolation.
- All safety-related electrical power is provided from the Class 1E dc power system. No separate safety-related ac power system is required.

1.2.1.5.3 Control Room Design

- A main control room is provided that is able to control the plant during normal and anticipated transients and design basis accidents. The main control room includes indications and controls capable of monitoring and controlling the plant safety systems as well as the nonsafety-related control systems.
- A remote shutdown capability is provided. The remote shutdown workstation contains the safety-related indications and controls that allow an operator to achieve and maintain safe shutdown of the plant following an event when the main control room is unavailable. Additional nonsafety-related indications and controls are provided as described in Chapter 7.
- The remote shutdown workstation contains indications and controls consistent with its intended use; i.e., the remote shutdown workstation is to be used in the unlikely event that the main control room is not available.
- Access to the remote shutdown workstation transfer mechanism is under strict administrative control.
- The main control room is serviced by reliable and redundant nonsafety-related power sources and heating, ventilation and air conditioning systems during normal operation.
- In the unlikely event that the normal power source or the heating, ventilating and air conditioning system becomes unavailable, there are passive systems (batteries, compressed air) to support the main control room for up to 3 days.
- The main control room contains the safety-related instrumentation and controls to allow the operator to achieve and maintain safe shutdown following any design basis accident.
- The safety-related power sources and passive cooling system are designed to provide a habitable environment for the operating staff assuming that no ac power is available. Installed equipment provides for at least 3 days of operation, as stated above. After

3 days, it is possible to continue operation with the control room cooled and ventilated with the natural circulation of outside air.

- A mechanism is provided to allow the operating staff to transfer control from the main control room to the remote shutdown workstation.
- The system prevents spurious signals caused by fire damage from being issued to components once transfer to the remote shutdown workstation has been effected.
- The transfer of the control of components to the remote shutdown workstation is alarmed in the main control room.
- Both the main control room and the remote shutdown workstation are designed in accordance with human factors engineering principles and practices.
- Human factors considerations are utilized so that the indications and controls for the remote shutdown workstation are similar to those provided in the main control room.
- The safety-related instrumentation (equipment racks) is maintained at acceptable ambient conditions for 3 days following a loss of all ac power by using a passive cooling system. After 3 days, it is possible to continue operation with the the instrumentation and control rooms cooled by natural circulation of outside air.
- A technical support center is provided.

1.2.1.6 Plant Arrangement and Construction

1.2.1.6.1 Plant Arrangement

- The plant arrangement is comprised of five principal building structures; the nuclear island, the turbine building, the annex building, the diesel generator building, and the radwaste building (see Figure 1.2-3).
- The nuclear island is structurally designed to meet seismic Category I requirements as defined in Regulatory Guide 1.29. The nuclear island consists of a free-standing steel containment building, a concrete shield building, and an auxiliary building. The foundation for the nuclear island is an integral basemat which supports these buildings.
- The nuclear island structures are designed to withstand the effects of natural phenomena such as hurricanes, floods, tornados, tsunamis, and earthquakes without loss of capability to perform safety functions. Design for natural phenomena is based on the industry standards as described in Chapters 2 and 3.
- The nuclear island is designed to withstand the effects of postulated internal events such as fires and flooding without loss of capability to perform safety functions.

- The turbine building is designed to Uniform Building Code requirements. The turbine building is supported on a single basemat foundation.
- The annex building is designed to seismic Category II requirements and includes functions such as the health physics area, the technical support center, access control, and personnel facilities (shower and locker rooms).
- The diesel generator building houses two diesel generators and their associated heating, ventilation and air conditioning equipment. The building is a nonseismic structure designed for wind and seismic loads in accordance with the Uniform Building Code.
- The radwaste building contains facilities for the handling and storage of plant wastes. It is a nonseismic structure designed for wind and seismic loads in accordance with the Uniform Building Code. The foundation for the building is a reinforced concrete mat on grade.
- Radioactive equipment and piping in all buildings are arranged and shielded to minimize radiation exposure.
- The overall plant arrangement utilizes building configurations and structural designs to minimize the building volumes and quantities of bulk materials (concrete, structural steel, rebar) consistent with safety, operational, maintenance, and structural needs.
- The plant arrangement provides separation between safety-related and nonsafety-related systems to preclude adverse interaction between safety-related and nonsafety-related equipment. Separation between redundant safety-related equipment and systems provides confidence that the safety design functions can be performed. In general this separation is provided by partitioning an area with concrete walls.
- The plant arrangement provides separation for radioactive and non-radioactive equipment and provides separate pathways to these areas for personnel access.
- Pathways through the plant are designed to accommodate equipment maintenance and equipment removal from within the plant. The size of the pathways is dictated by the largest appropriate piece of equipment that may have to be removed or installed after initial installation. Where required, laydown space is provided for disassembling large pieces of equipment to accommodate the removal or installation process.
- Adequate space is provided for equipment maintenance, laydown, removal and inspection. Hatches, monorails, hoists, and removable shield walls are provided to facilitate maintenance.

1.2.2 Site Description

Site Characteristics

The AP600 is a standard plant that is to be placed on a site with parameters bounded by those used as a basis for design certification as described in Chapter 2, Site Characteristics. The site parameters relate to the seismology, hydrology, meteorology, geology, heat sink and other site-related aspects. The allowable site interface parameters bound a large percentage of potential sites.

The AP600 is designed on the basis that the equipment, modules, structures, and bulk material can be shipped to the site by commercial rail or truck. This does not preclude the shipment of large equipment or structures by barges should a specific site be accessible by water.

Site Plan

The site plan is defined in the site specific licensing process. A proposed plan has been provided for site interface purposes. Specific details of the site plan will be covered in the site application or in the combined license application.

A typical site plan for the single unit AP600 reference is shown on Figure 1.2-2. Direction of north, south, east and west used in this description are nominal site description directions and have no relationship to directions on an actual site. With the exception of the parking area, the entire facility is contained within the perimeter fence. The area within the 1400 feet x 725 feet perimeter fence is approximately 23 acres. The gatehouse at the main gate controls ingress and egress to and from the site.

As previously stated in subsection 1.2.1.6.1, the power block complex consists of five principal building structures; the nuclear island, the turbine building, the annex building, the diesel generator building and the radwaste building. Each of these building structures is constructed on an individual basemat. The nuclear island consists of the containment building, the shield building, and the auxiliary building, all of which are constructed on a common basemat.

As shown on the site plan, Figure 1.2-2, these building structures are oriented such that the turbine building is located to the north of the nuclear island, with the other principal buildings adjacent to the nuclear island to meet their functional purpose and to provide access control to vital areas from a central security control point located within the annex building.

The reference plant main cooling tower-circulating water pump complex consists of a natural draft cooling tower, a pump basin, and two circulating water pumps. The final configuration of the cooling tower is site-specific.

The two circulating water pumps circulate the cooling water from the pump basin to the main condenser and back to the cooling tower through two precast concrete supply and return pipes

that are below grade. These two circulating water pipes are shown on Figure 1.2-2 between the main cooling tower and the turbine building.

The transformer area is located immediately adjacent to and north of the turbine building. The unit auxiliary transformers, the reserve auxiliary transformer and the main step-up transformers are located in the transformer area. The main switchyard area is site-specific.

The rail and road accesses to the site are through the east perimeter fence. The rail access to the auxiliary building is primarily for the transportation of new and spent fuel. A rail access to the turbine building is also provided.

During construction, a heavy lift crane is used to place major pieces of equipment such as the turbine-generator, the reactor vessel, the steam generators, containment ring sections, large structural modules and other large or heavy equipment modules.

Figure 1.2-3 provides a functional representation of the principal systems and components that are located in each of the key AP600 buildings. This figure identifies major systems and components that are contained in these structures.

1.2.3 Plant Arrangement Description

Building Definition

A set of the general arrangement drawings for the AP600 is provided in Figures 1.2-4 through 1.2-30.

The AP600 consists of the following five principal structures. Each of these buildings is constructed on an individual basemat:

- Nuclear island
- Turbine building
- Annex building
- Diesel generator building
- Radwaste building

The structures that make up the nuclear island are:

- Containment building
- Shield building
- Auxiliary building

These nuclear island buildings are depicted on the site plan. The safety-related equipment designed to perform accident mitigation functions is located in the nuclear island.

1.2.4 Nuclear Island

1.2.4.1 Containment Building

Building Function

The containment building is the containment vessel and the structures contained within the containment vessel. The containment building is an integral part of the overall containment system with the functions of containing the release of airborne radioactivity following postulated design basis accidents and providing shielding for the reactor core and the reactor coolant system during normal operations.

The containment vessel is an integral part of the passive containment cooling system. The containment vessel and the passive containment cooling system are designed to remove sufficient energy from the containment to prevent the containment from exceeding its design pressure following postulated design basis accidents.

The containment building is designed to house the reactor coolant system and other related systems and provides a high degree of leak tightness.

Civil/Structural Features

The containment building, a seismic Category I structure, is a freestanding cylindrical steel containment vessel with elliptical upper and lower heads. It is surrounded by a seismic Category I reinforced concrete shield building.

Figures 1.2-13 through 1.2-16 provide sectional views through the containment that show the configuration of the containment vessel and the internal structures of the containment.

There are two floor elevations (grade access maintenance floor and operating deck) and four lower equipment compartments within the containment building. Floor gratings are provided for access to equipment at other elevations.

Figures 1.2-7, 1.2-8, 1.2-9, 1.2-15, and 1.2-16 depict the configuration of the refueling water storage tank. This tank is located below the operating deck. The capacity of the refueling water storage tank exceeds the quantity of water required to accomplish safety functions or to fill the refueling cavity during refueling operations. The refueling cavity has two floor elevations. The upper and lower reactor internals storage area is at the lower elevation as is the fuel transfer tube.

Equipment Arrangement

The principal system located within the containment building is the reactor coolant system that consists of two main coolant loops, a reactor vessel, two steam generators, four canned motor

reactor coolant pumps, and a pressurizer. Figures 1.2-9, 1.2-14 and 1.2-16 depict the reactor coolant system component locations in the containment.

The main steam and feedwater lines are routed from the steam generators to a horizontal run below the operating deck. The steam and feedwater lines penetrate the north side of the containment vessel and are routed through the main steam isolation valve area in the auxiliary building to the turbine island.

The passive core cooling system is also located in the containment building. The primary components of the passive core cooling system are two core makeup tanks, two accumulators, the refueling water storage tank, the passive residual heat removal heat exchanger, and two spargers. The first three stages of the automatic depressurization valves are located above the pressurizer and consist of a two-tier valve module.

The passive residual heat removal heat exchanger and the spargers are located within the refueling water storage tank (Figures 1.2-7 and 1.2-9). The core makeup tanks are located on floor elevation 107'2" level (Figures 1.2-7 and 1.2-9).

The chemical and volume control system equipment module is located in the containment below the maintenance floor level. This module represents the high pressure purification loop of the chemical and volume control system (Figure 1.2-14).

The reactor coolant drain tank, the reactor coolant drain tank heat exchanger and the containment sump pumps are located in the compartment adjacent to the reactor vessel cavity. Access to the reactor vessel cavity is via a stairwell that descends from the maintenance floor (Figure 1.2-14).

Two containment recirculation cooling units are located adjacent to the steam generator compartments. Each unit consists of two vane axial fans, cooling coils and the associated exit ducts and inlet plenum. The four recirculation fans are connected to the common exit plenum (ring header). Several vertical ducts branch off from the ring header to provide cooling flow to the lower compartments in the containment while other vertical ducts are directed up to provide cooling flow to the upper regions of the containment vessel.

Equipment and Material Handling

A seismic Category I polar crane is provided in the containment and its bridge is sized for lifting the steam generator during a steam generator removal operation. A temporary construction trolley is required for this operation. The polar crane support is attached to the steel cylindrical shell of the containment as shown in Figures 1.2-14 and 1.2-16.

The layout of the containment is designed to permit the removal of either steam generator through the main equipment hatch. During a steam generator removal operation, the steam generator is lifted from the steam generator compartment by the polar crane.

The polar crane trolley is designed for normal refueling operations such as lifting the integrated head package, the lower internals package and the upper internals package.

An auxiliary hook is provided with the polar crane for easier movement of smaller equipment. The polar crane is used for lifting reactor coolant pump motor/impeller assemblies from the steam generator/loop compartments to the operating deck in the event that the reactor coolant pump motor/impeller assemblies have to be removed from the containment for major maintenance.

A reactor coolant pump maintenance cart is provided for use in either of the two steam generator/loop compartments for removing the reactor coolant pump motor/impeller assemblies from the bottom head of the steam generators. This maintenance cart transports the reactor coolant pump motor/impeller assemblies to a designated area in each of the steam generator/loop compartments where the assemblies are lifted from the compartment to the operating deck by the polar crane. Removable sections of grating at all platform levels in the steam generator/loop compartments permit direct access to the pumps. From the operating deck level, the reactor coolant pump motor/impeller assemblies are removed from the containment via the main equipment hatch into the annex building maintenance area.

A refueling machine is provided to move fuel between the fuel transfer system and the reactor core (Figure 1.2-14). The refueling machine consists of a rectilinear bridge and a trolley crane with a vertical mast extending down into the refueling cavity. The bridge spans the refueling cavity and runs on rails set into the edge of the refueling cavity. The bridge and trolley motions are used to position the vertical mast over a fuel assembly. In addition, the refueling machine is equipped with an auxiliary hoist which provides additional capability for other refueling operations.

A fuel transfer system is provided to transfer nuclear fuel assemblies between the refueling cavity in the containment building and the fuel transfer canal/spent fuel pit located in the fuel handling area of the auxiliary building. The fuel transfer system also has the capability to transfer control rod clusters.

Building Access and Exit

Access to the containment is provided through a personnel airlock and the main equipment hatch located at the operating deck level and a personnel airlock and a maintenance hatch at the maintenance floor level. Access to the containment can be controlled by the health physics office in the annex building.

In the event that large numbers of temporary personnel require access to the containment during a major outage, temporary personnel facilities can be provided immediately adjacent to the health physics area in the annex building.

1.2.4.2 Shield Building

Building Function

The shield building is the structure that surrounds the containment vessel. During normal operations, a primary function of the shield building is to provide shielding for the containment vessel and the radioactive systems and components located in the containment building. The shield building, in conjunction with the internal structures of the containment building, provides the required shielding for the reactor coolant system and the other radioactive systems and components housed in the containment.

Another function of the shield building is to protect the containment building from external events. The shield building protects the containment vessel and the reactor coolant system from the effects of tornadoes and tornado produced missiles.

During accident conditions, the shield building provides the required shielding for radioactive airborne materials that may be dispersed in the containment as well as radioactive particles in the water distributed throughout the containment.

The shield building is an integral part of the passive containment cooling system.

Civil/Structural Features

The shield building is a seismic Category I reinforced concrete structure. It shares a common basemat with the containment building and the auxiliary building.

Figures 1.2-13 through 1.2-16 provide sectional views of the shield building which show the basic configuration of the shield building and the annulus area between the containment vessel and the shield building.

The following items represent the significant features of the shield building and the annulus area:

- Shield building cylindrical structure
- Shield building roof structure
- Lower annulus area
- Middle annulus area
- Upper annulus area
- Passive containment cooling system air inlet
- Passive containment cooling system air inlet plenum
- Passive containment cooling system water storage tank
- Passive containment cooling system air diffuser
- Passive containment cooling system air baffle

The cylindrical section of the shield building serves as shielding and a missile barrier and is a key component of the passive containment cooling system. It structurally supports the roof and is a major structural member for the entire nuclear island. Floor slabs and structural walls of the auxiliary building are structurally connected to the cylindrical section of the shield building.

A watertight seal is provided between the upper and middle annulus areas to provide an environmental barrier. The middle annulus area contains the majority of containment penetrations and radioactive piping. This environmental barrier is provided to protect against the following:

- In the event of an accident or spurious actuation, the passive containment cooling system drains the system water storage tank. The water, which runs down the outside of the containment vessel, is prevented from draining into the middle annulus area by the watertight seal. Drains are provided to direct the passive containment cooling system runoff water out of the shield building.
- The passive containment cooling system is designed to perform with the upper annulus permanently open to the environment to permit sufficient air flow through the shield building in the event of an accident. The watertight seal protects the middle annulus area from ambient environmental conditions.

The shield building roof is a reinforced concrete conical shell supporting the passive containment cooling system water storage tank and air diffuser. Air intakes are located at the top of the cylindrical portion of the shield building. The conical roof supports the passive containment cooling system water storage tank which is constructed with a stainless steel liner attached to reinforced concrete walls. The air diffuser in the center of the roof discharges containment cooling air directly upwards.

The passive containment cooling system air baffle is located in the upper annulus area. It is attached to the cylindrical section of the containment vessel. The function of the passive containment cooling system air baffle is to provide a pathway for natural circulation of cooling air in the event that a design basis accident results in a large release of energy into the containment. In this event the outer surface of the containment vessel transfers heat to the air between the baffle and the containment shell. This heated and thus, lower density air flows up through the air baffle to the air diffuser and cooler and higher density air is drawn into the shield building through the air inlets at the top cylindrical portion of the shield building.

Equipment and Material Handling

A monorail is provided in the upper annulus area of the shield building to facilitate the initial installation of the passive containment cooling system air baffle panels and to permit the removal of these air baffle panels when an inspection or repainting of the containment vessel is required.

Two personnel workstation platforms are provided for transporting staff and equipment from the operating deck floor level of the upper annulus area to the top of the shield building. The work station platforms are powered from their respective monorail sections and are able to be positioned at any circumferential position or height beneath the monorail sections. Figures 1.2-14 and 1.2-16 depict the monorail system and the personnel work station platforms.

1.2.4.3 Auxiliary Building

Building Function

The primary function of the auxiliary building is to provide protection and separation for the seismic Category I mechanical and electrical equipment located outside the containment building.

The auxiliary building provides protection for the safety-related equipment against the consequences of either a postulated internal or external event. The auxiliary building also provides shielding for the radioactive equipment and piping that is housed within the building.

The most significant equipment, systems, and functions contained within the auxiliary building are the following:

- Main control room
- Class 1E instrumentation and control systems
- Class 1E electrical system
- Fuel handling area
- Mechanical equipment areas
- Containment penetration areas
- Main steam and feedwater isolation valve compartment

Main control room: The main control room provides the human system interfaces required to operate the plant safely under normal conditions and to maintain it in a safe condition under accident conditions. The main control room includes the main control area, the operations staff area, the switching and tagging room and offices for the shift supervisor and administrative support personnel.

Instrumentation and control systems: The protection and safety monitoring system and the plant control system provide monitoring and control of the plant during startup, ascent to power, powered operation, and shutdown. The instrumentation and control systems include the protection and safety monitoring system, the plant control system, and the data display and processing system.

Class 1E electrical system: The Class 1E system provides 125 volts dc power for safety-related and vital control instrumentation loads including monitoring and control room

emergency lighting. It is required for safe shutdown of the plant during a loss of ac power and during a design basis accident with or without concurrent loss of offsite power.

Fuel handling area: The primary function of the fuel handling area is to provide for the handling and storage of new and spent fuel. The fuel handling area in conjunction with the annex building provides the means for receiving, inspecting and storing the new fuel assemblies. It also provides for safe storage of spent fuel as described in DCD Section 9.1, Fuel Storage and Handling.

The fuel handling area provides for transferring new fuel assemblies from the new fuel storage area to the containment building and for transferring spent fuel assemblies from the containment building to the spent fuel storage pit within the auxiliary building.

The fuel handling area provides the means for removing the spent fuel assemblies from the spent fuel storage pit and loading the assemblies into a shipping cask for transfer from the facility.

The fuel handling area is protected from external events such as tornadoes and tornado produced missiles. Protection is provided for the spent fuel assemblies, the new fuel assemblies and the associated radioactive systems from external events.

The fuel handling area is constructed so that the release of airborne radiation following any postulated design basis accident that could result in damage to the fuel assemblies or associated radioactive systems does not result in unacceptable site boundary radiation levels.

Mechanical equipment areas: The mechanical equipment located in radiological control areas of the auxiliary building are the normal residual heat removal pumps and heat exchangers, the spent fuel cooling system pumps and heat exchangers, the solid, liquid, and gaseous radwaste pumps, tanks, demineralizers and filters, the chemical and volume control pumps, and the heating, ventilating and air conditioning exhaust fans.

The mechanical equipment located in the clean areas of the auxiliary building are the heating, ventilating and air conditioning air handling units, associated equipment that service the main control room, instrumentation and control cabinet rooms, the battery rooms, the passive containment cooling system recirculation pumps and heating unit and the equipment associated with the air cooled chillers that are an integral part of the chilled water system.

Containment penetration areas: The auxiliary building contains all of the containment penetration areas for mechanical, electrical, and instrumentation and control penetrations. The auxiliary building provides separation of the radioactive piping penetration areas from the non-radioactive penetration areas and separation of the electrical and instrumentation and control penetration areas from the mechanical penetration areas. Also provided is separation of redundant divisions of instrumentation and control and electrical equipment.

Main steam and feedwater isolation valve compartment: The main steam and feedwater isolation valve compartment is contained within the auxiliary building. The auxiliary building provides an adequate venting area for the main steam and feedwater isolation valve compartment in the event of a postulated leak in either a main steam line or feedwater line.

Civil/Structural Features

The auxiliary building is a seismic Category I reinforced concrete structure. It shares a common basemat with the containment building and the shield building.

The auxiliary building wraps around approximately 70 percent of the circumference of the shield building. Floor slabs and the structural walls of the auxiliary building are structurally connected to the cylindrical section of the shield building.

Equipment and Material Handling

A cask handling crane is located in the fuel handling area of the auxiliary building. The cask handling crane is designed to transport the spent fuel cask between the rail car, the cask loading pit, and the cask washdown pit. The crane rail length and rail stop limits the crane travel and thus precludes the movement of this crane in the near vicinity of the spent fuel pit. A jib crane is provided to transfer new fuel from the new fuel racks to the new fuel elevator. A bridge crane is provided in the rail car bay for handling the spent resin waste container fill station cover, the spent resin waste container, and the high activity filter transfer casks.

The major components of the fuel transfer system are located in the fuel transfer canal. The fuel transfer system is designed to transfer fuel assemblies between the fuel transfer canal located in the fuel handling area and the refueling cavity located in the containment building. The fuel transfer system consists of a transfer car/fuel container, a drive car, a traverse drive mechanism, an upending mechanism, the transfer tube, a quick opening hatch on the containment side of the transfer tube and a valve on the fuel handling area side of the transfer tube.

A spent fuel handling machine is provided to move the spent fuel assemblies between the fuel transfer canal, the spent fuel pool and the cask loading pit. The spent fuel pool handling machine consists of a rectilinear bridge and a trolley crane with a vertical mast extending down into the spent fuel pool.

The high bay area is designed for a rail car to enter the building through a slide-up door. When used to transport a spent fuel cask to the fuel handling area, the rail car is positioned in the high bay area and the cask lifting rig is attached to the cask handling crane. When the cask is in the vertical position, it is disconnected from the trunnion and lifted to the operating deck through the equipment hatch and placed in the cask loading pit.

1.2.5 Annex Building

Building Function

The annex building (Figures 1.2-17 through 1.2-20) provides the main personnel entrance to the power generation complex. It includes accessways for personnel and equipment to the clean areas of the nuclear island in the auxiliary building and to the radiological control area. The building includes the health physics facilities for the control of entry to and exit from the radiological control area as well as personnel support facilities such as locker rooms. The building also contains the non-1E ac and dc electric power systems, the ancillary diesel generators and their fuel supply, other electrical equipment, the technical support center, and various heating, ventilating and air conditioning systems. No safety-related equipment is located in the annex building.

The annex building includes the health physics facilities and provides personnel and equipment accessways to and from the containment building and the rest of the radiological control area via the auxiliary building. Provided are large, direct accessways to the upper and lower equipment hatches of the containment building for personnel access during outages and for large equipment entry and exit. The building includes a hot machine shop for servicing radiological control area equipment. The hot machine shop includes decontamination facilities including a portable decontamination system that may be used for decontamination operations throughout the nuclear island.

Civil/Structural Features

The annex building is a seismic Category II structure except for that portion of the building between column lines A and D, which is non-seismic. It is designed so that it will not fail in a manner that would damage safety-related structures. No protection against missile penetration is required. However, certain areas of the building, such as the hot machine shop and the technical support center, are provided with shielding for protection against low level radiation from either internal sources or external sources under accident conditions. This is accomplished by either reinforced concrete walls or reinforced masonry walls.

The annex building is a combination of reinforced concrete structure and steel framed structure with insulated metal siding. Floor and roof slabs are reinforced concrete supported by metal decking. Floors are designed to act as diaphragms to transmit horizontal loads to side wall bracing and to concrete shear walls. The building foundation is a reinforced concrete mat.

1.2.6 Diesel Generator Building

Building Function

The diesel generator building (Figure 1.2-21) houses two identical slide along diesel generators separated by a three hour fire wall. These generators provide backup power for

plant operation in the event of disruption of normal power sources. No safety-related equipment is located in the diesel generator building.

Civil/Structural Features

The diesel generator building houses the two diesel generators and their associated heating, ventilating and air conditioning equipment, none of which are required for the safe shutdown of the plant. Accordingly, the building is designed as a nonseismic structure subject to seismic and wind loads in accordance with the Uniform Building Code.

The building is a single story steel framed structure with insulated metal siding. The roof is composed of a metal deck supporting a concrete slab and serves as a horizontal diaphragm to transmit lateral loads to sidewall bracing and thereby to the foundation.

The foundation consists of a reinforced concrete mat. The diesel generators are skid-mounted and rest on vibration isolators supported directly from the mat.

1.2.7 Radwaste Building

Building Function

The radwaste building includes facilities for segregated storage of various categories of waste prior to processing, for processing by mobile systems, and for storing processed waste in shipping and disposal containers. No safety-related equipment is located in the radwaste building. Dedicated floor areas and trailer parking space for mobile processing systems is provided for the following:

- Contaminated laundry shipping for offsite processing
- Dry waste processing and packaging
- Hazardous/mixed waste shipping for offsite processing
- Chemical waste treatment
- Empty waste container receiving and storage
- Storage and loading packaged wastes for shipment

The radwaste building also provides for temporary storage of other categories of plant wastes.

Civil/Structural Features

The radwaste building general arrangement is shown on Figure 1.2-22. The radwaste building is a nonseismic structure designed in accordance with the Uniform Building Code. The liquid radwaste processing areas are designed to contain any liquid spills. These provisions include a raised perimeter and floor drains that lead to the liquid radwaste system waste holdup tanks. The foundation for the entire building is a reinforced concrete mat on grade.

1.2.8 Turbine Building

Building Function

The turbine building houses the main turbine, generator, and associated fluid and electrical systems. It provides weather protection for the laydown and maintenance of major turbine/generator components. The turbine building also houses the makeup water purification system. No safety-related equipment is located in the turbine building.

Civil/Structure Features

The turbine building, shown in Figures 1.2-23 through 1.2-30, is a steel column and beam structure. The turbine building ground floor (structural mat) is a reinforced concrete slab. The turbine building is a nonseismic structure designed for wind and seismic loads in accordance with the Uniform Building Code.

The turbine-generator is low-tuned by means of spring supports. The design consists of a reinforced concrete deck mounted on springs. The springs are supported on a structural steel framework that forms an integral part of the turbine building structural system. Lateral bracing serves to provide lateral support for the building as well as the turbine-generator support. The spring-supported concept isolates dynamically the turbine-generator deck from the remainder of the structure for operating frequencies, thus allowing for an integrated structure below the deck. This includes an integrated reinforced concrete foundation mat that supports both the turbine generator and the building. The condenser is attached rigidly to the low pressure turbine exhaust and is supported on springs. The foundation for the entire building is a reinforced concrete mat.

1.2.9 Combined License Information

This section has no requirement for additional information to be provided in support of the Combined License application.

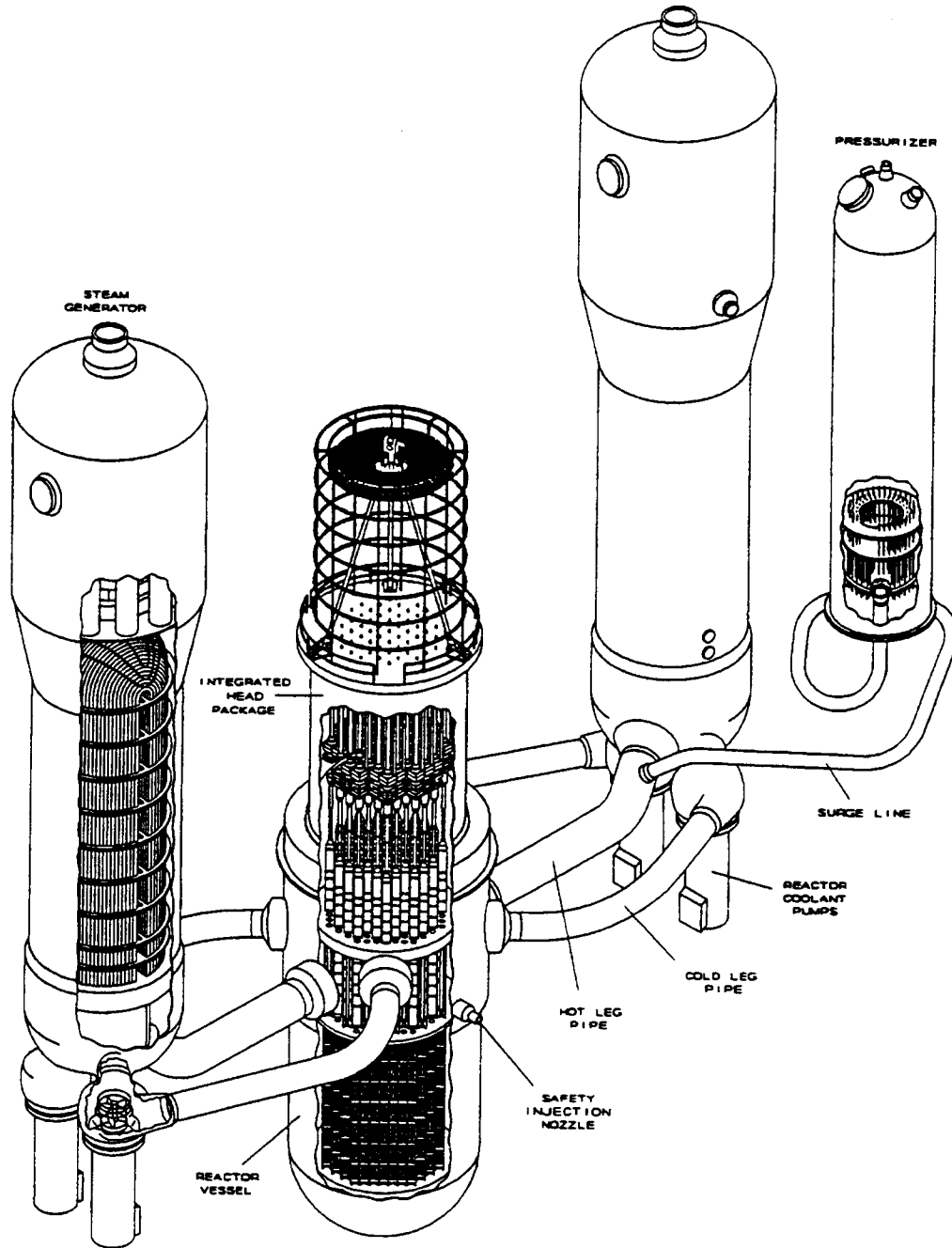

Figure 1.2-1

Reactor Coolant System

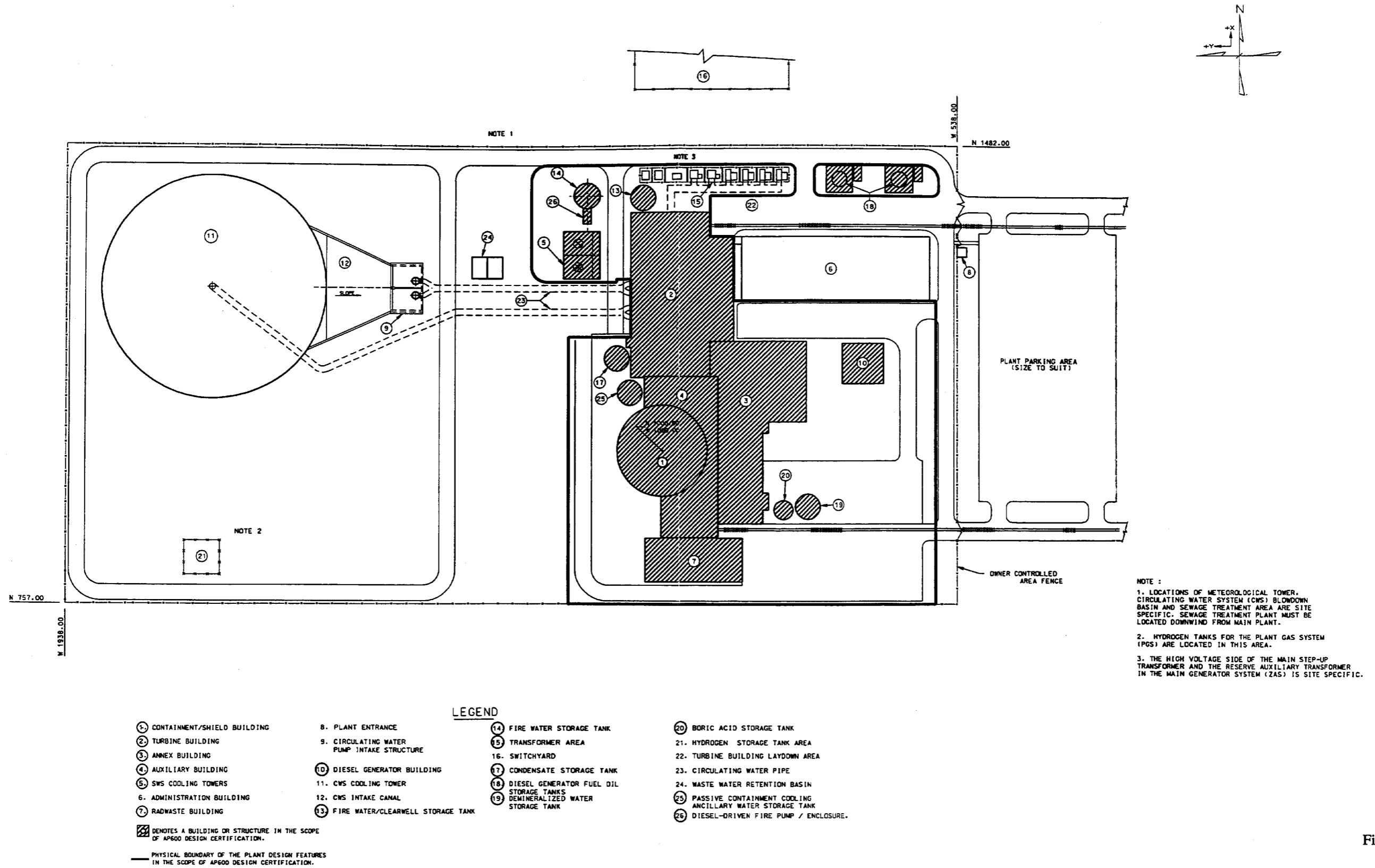

Figure 1.2-2

Site Plan

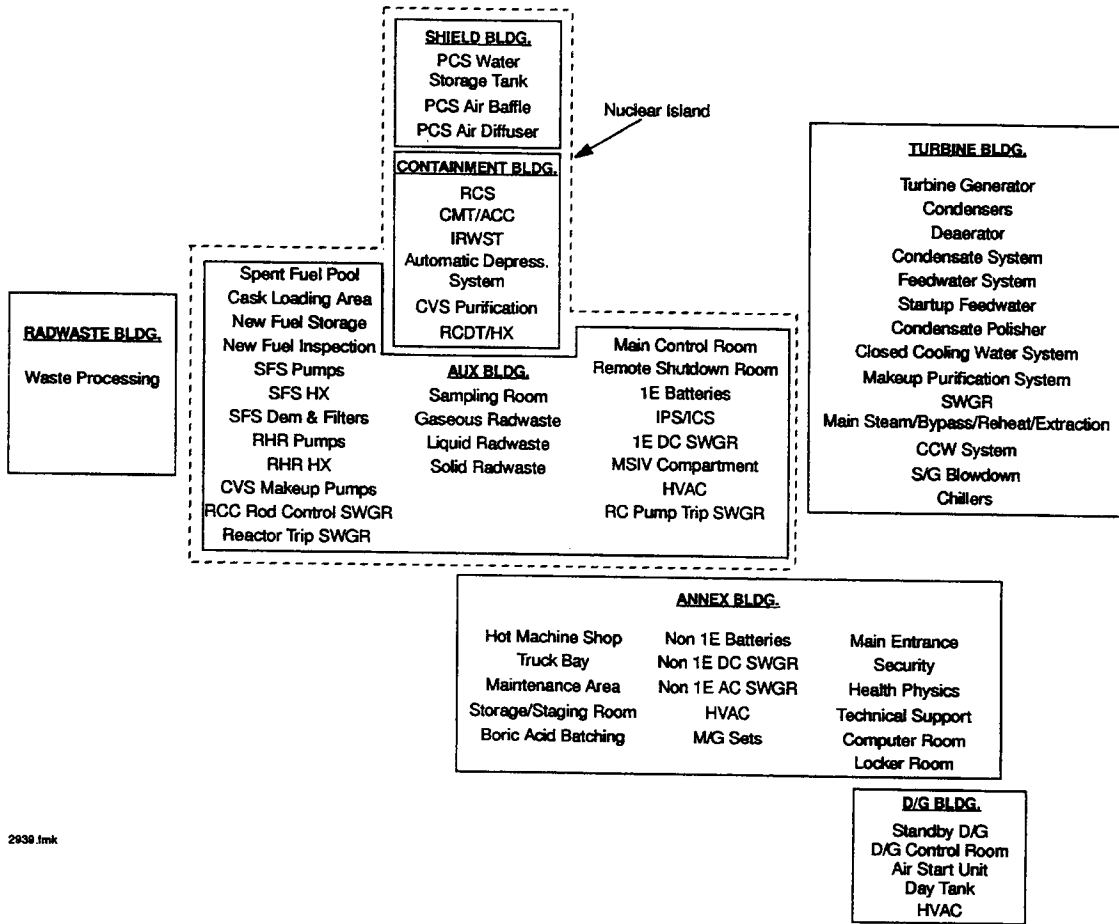

Figure 1.2-3

Functional Allocation of System Components of AP600 Power Generation Complex

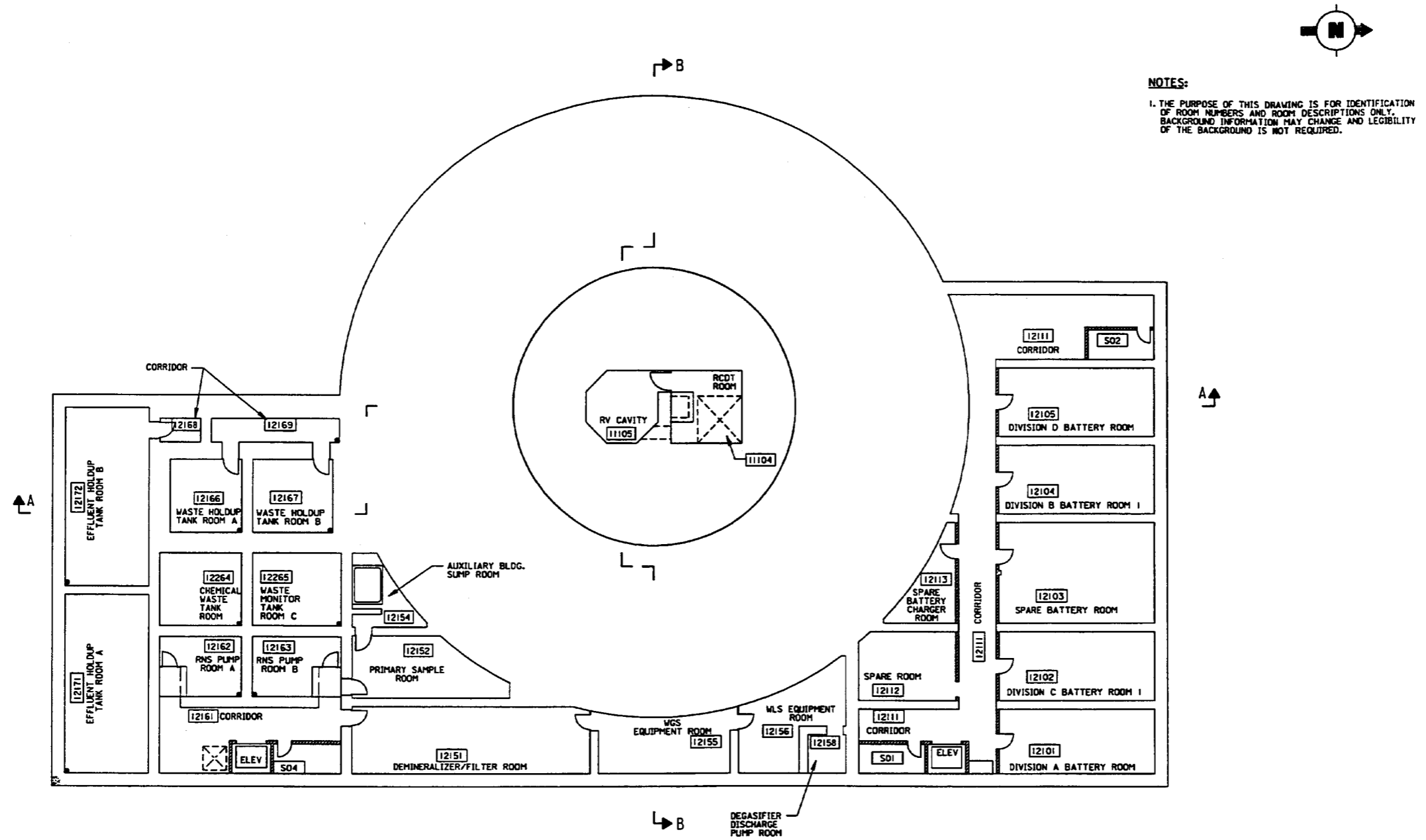

Figure 1.2-4

Nuclear Island General Arrangement
Plan at Elevation 66'-6"

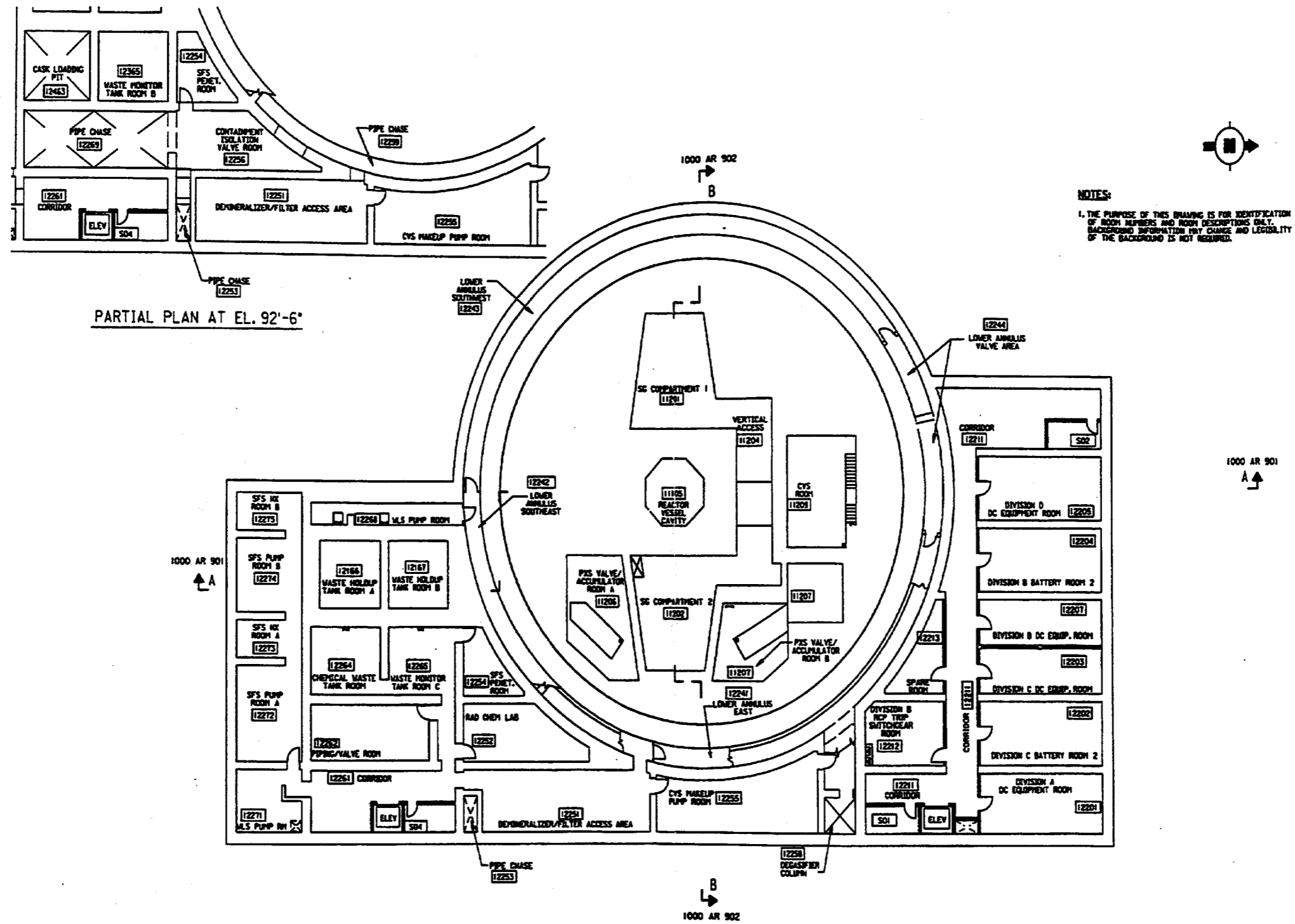

Figure 1.2-5

Nuclear Island General Arrangement Plan at Elevation 82'-6" & 92'-6"



NOTES:

1. THE PURPOSE OF THIS DRAWING IS FOR IDENTIFICATION OF ROOM NUMBERS AND ROOM DESCRIPTIONS ONLY. BACKGROUND INFORMATION MAY CHANGE AND LEGIBILITY OF THE BACKGROUND IS NOT REQUIRED.

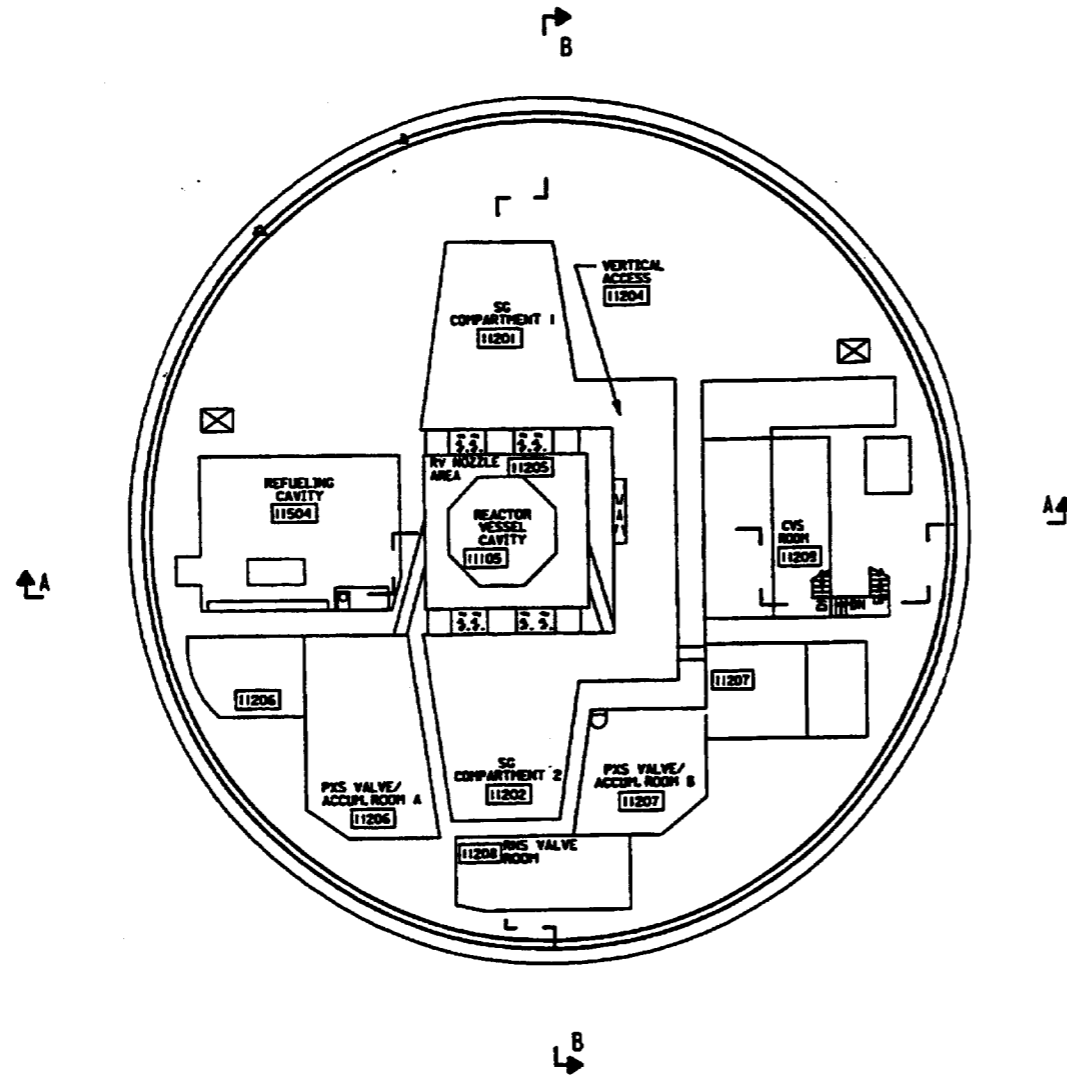

Figure 1.2-6

Nuclear Island General Arrangement

Plan at Elevation 96'-6"

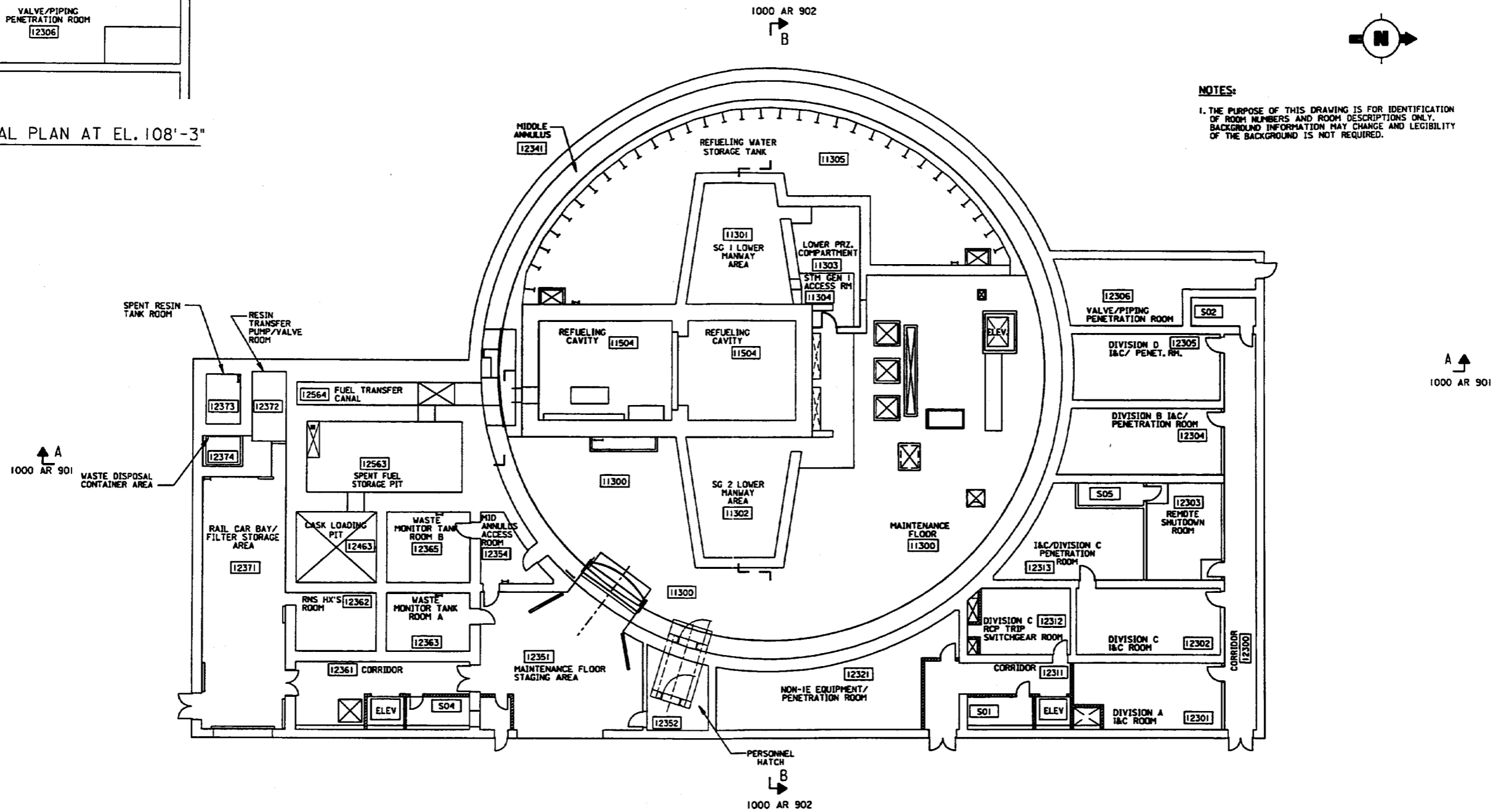
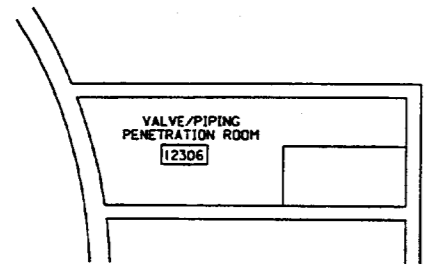
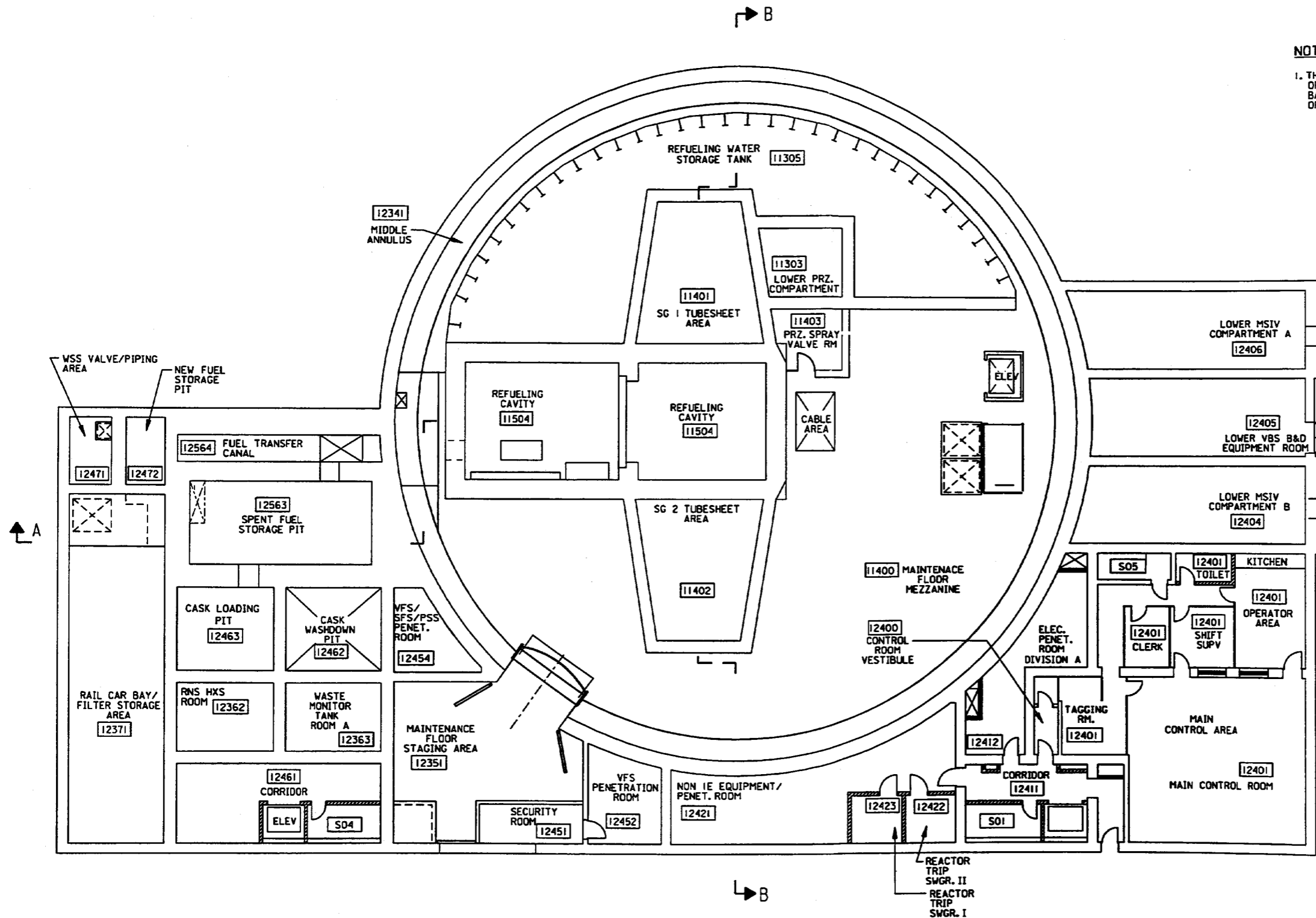
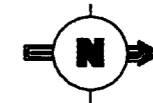

Figure 1.2-7

Nuclear Island General Arrangement Plan at Elevation 100'-0" & 107'-2"



NOTES:

1. THE PURPOSE OF THIS DRAWING IS FOR IDENTIFICATION OF ROOM NUMBERS AND ROOM DESCRIPTIONS ONLY. BACKGROUND INFORMATION MAY CHANGE AND LEGIBILITY OF THE BACKGROUND IS NOT REQUIRED.

Figure 1.2-8

Nuclear Island General Arrangement Plan at Elevation 117'-6"

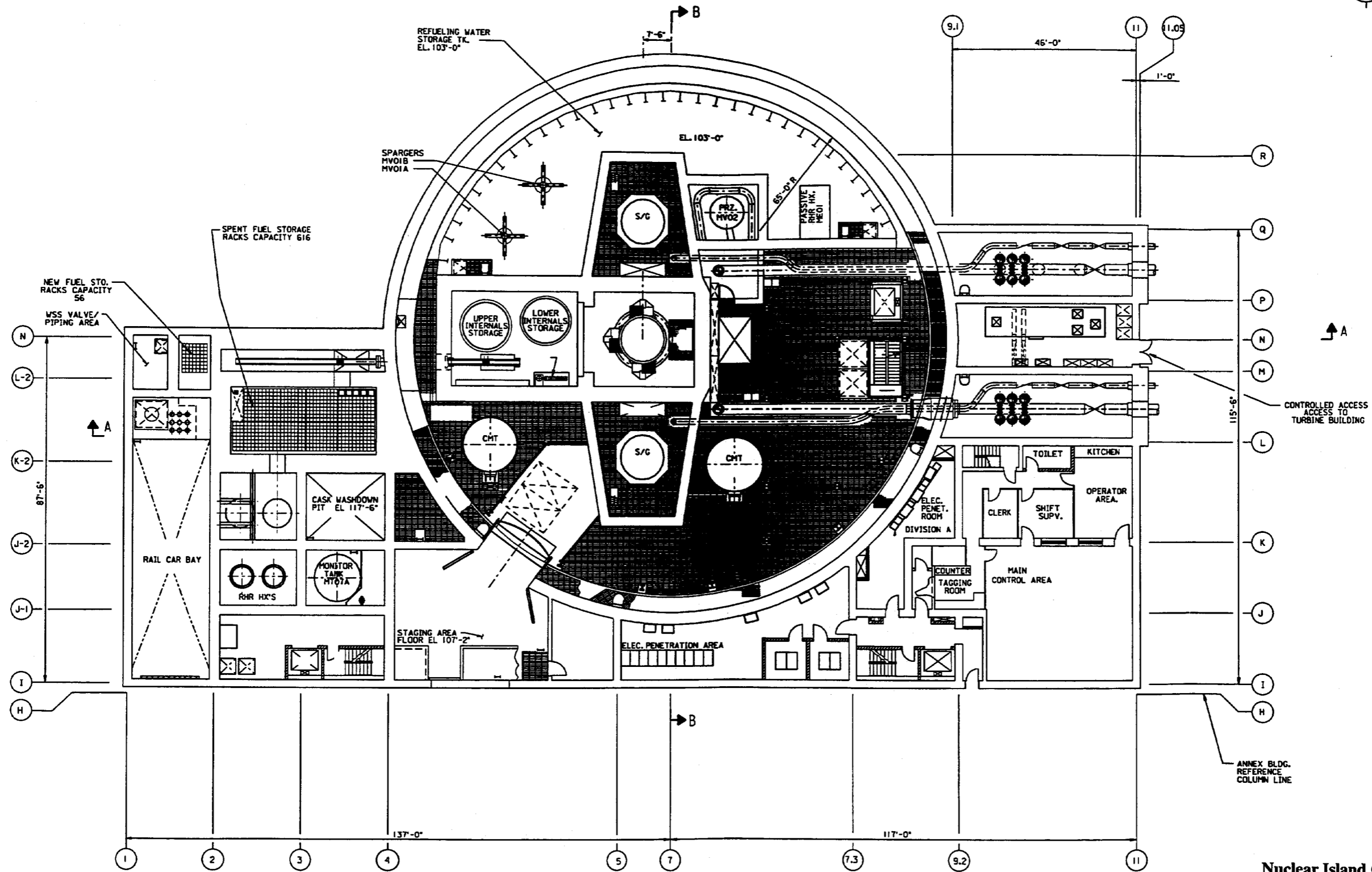

Figure 1.2-9

Nuclear Island General Arrangement Plan at Elevation 117'-6" with Equipment

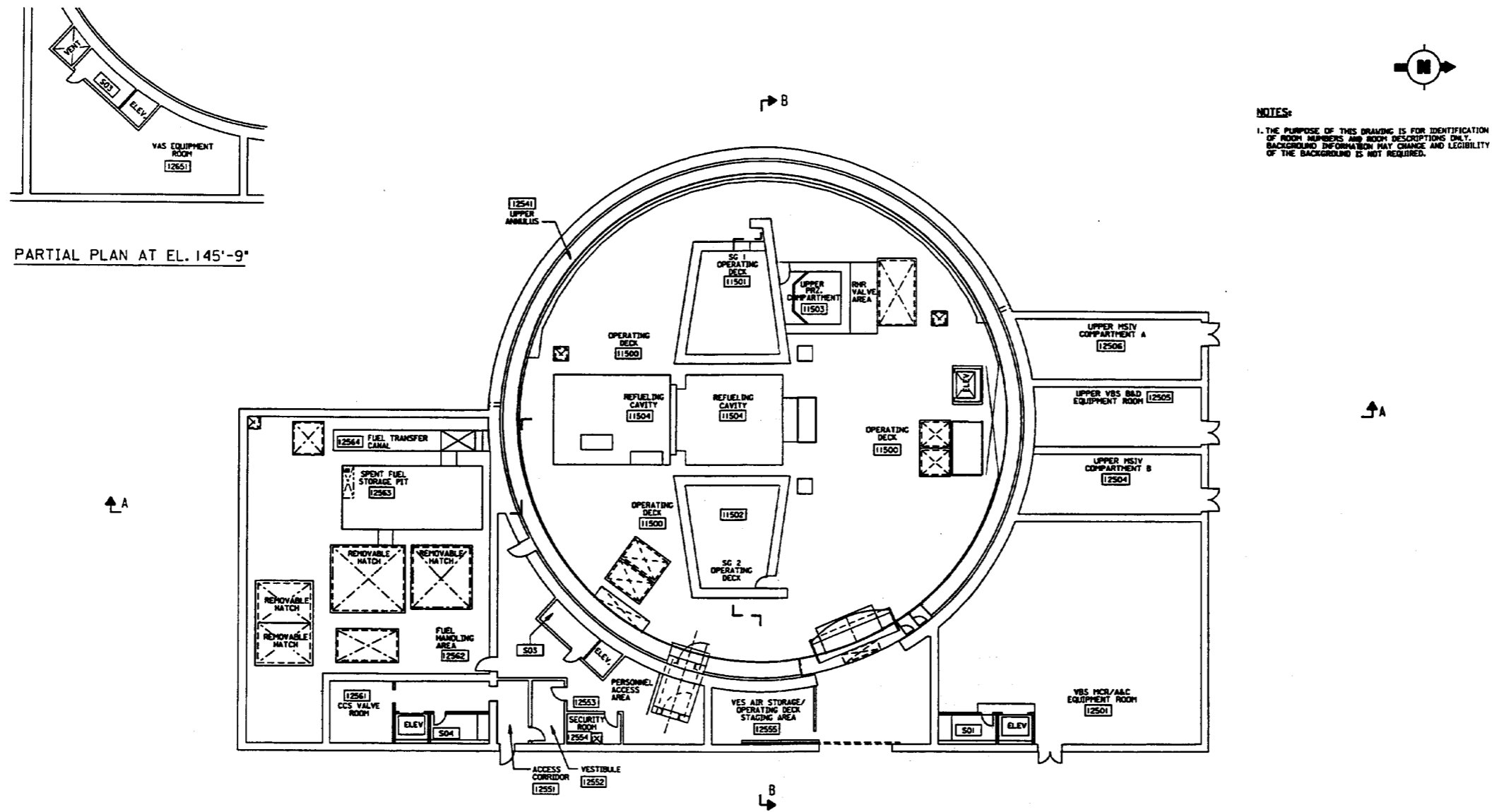
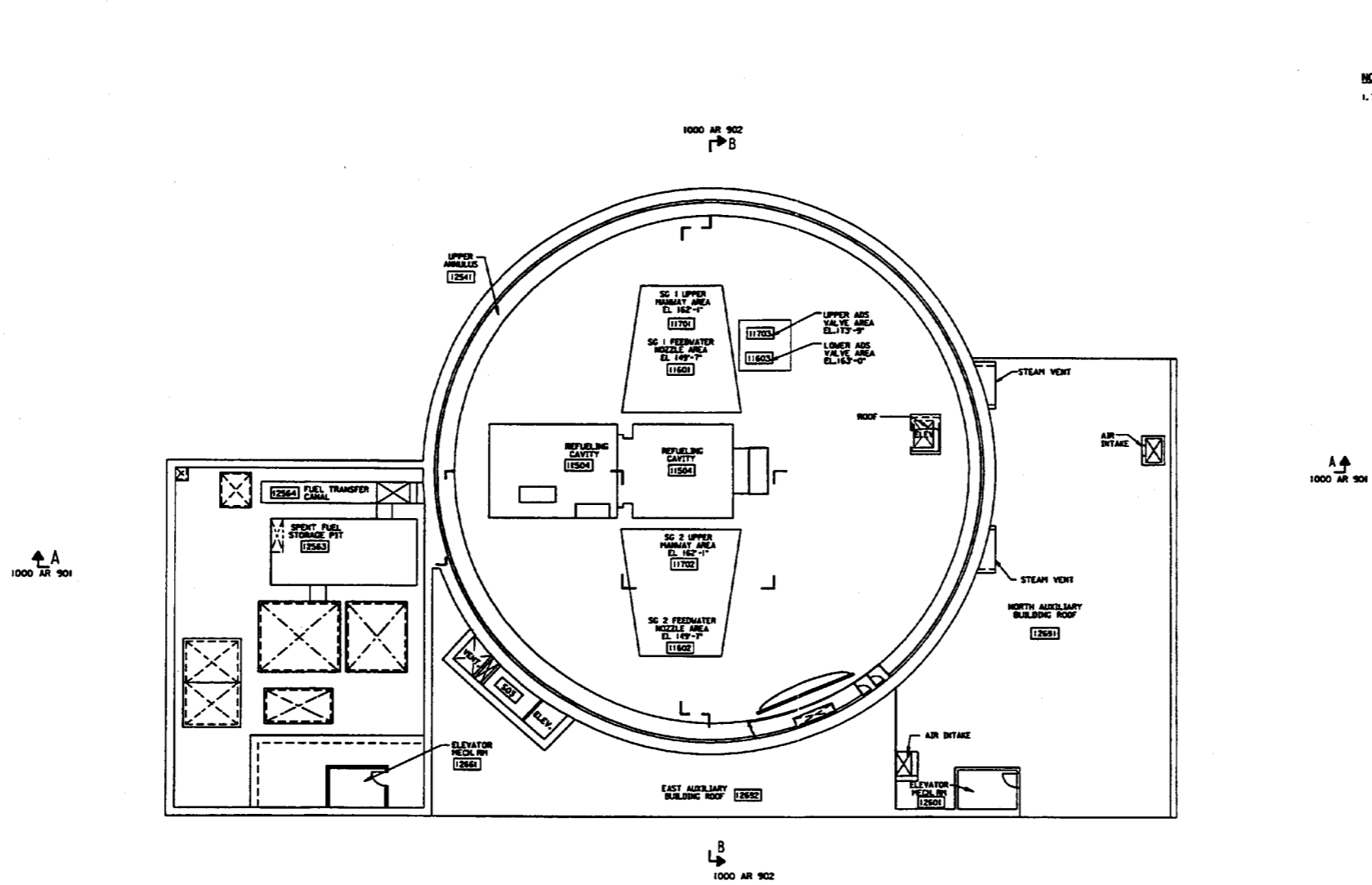

Figure 1.2-10

Nuclear Island General Arrangement
Plan at El. 135'-3" & 145'-9"



NOTES:
 1. THE PURPOSE OF THIS DRAWING IS FOR IDENTIFICATION OF ROOM NUMBERS AND ROOM DESCRIPTIONS ONLY. BACKGROUND INFORMATION MAY CHANGE AND LEGIBILITY OF THE BACKGROUND IS NOT REQUIRED.

Figure 1.2-11

Nuclear Island General Arrangement
 Plan at El. 153'-0" & 160'-6"

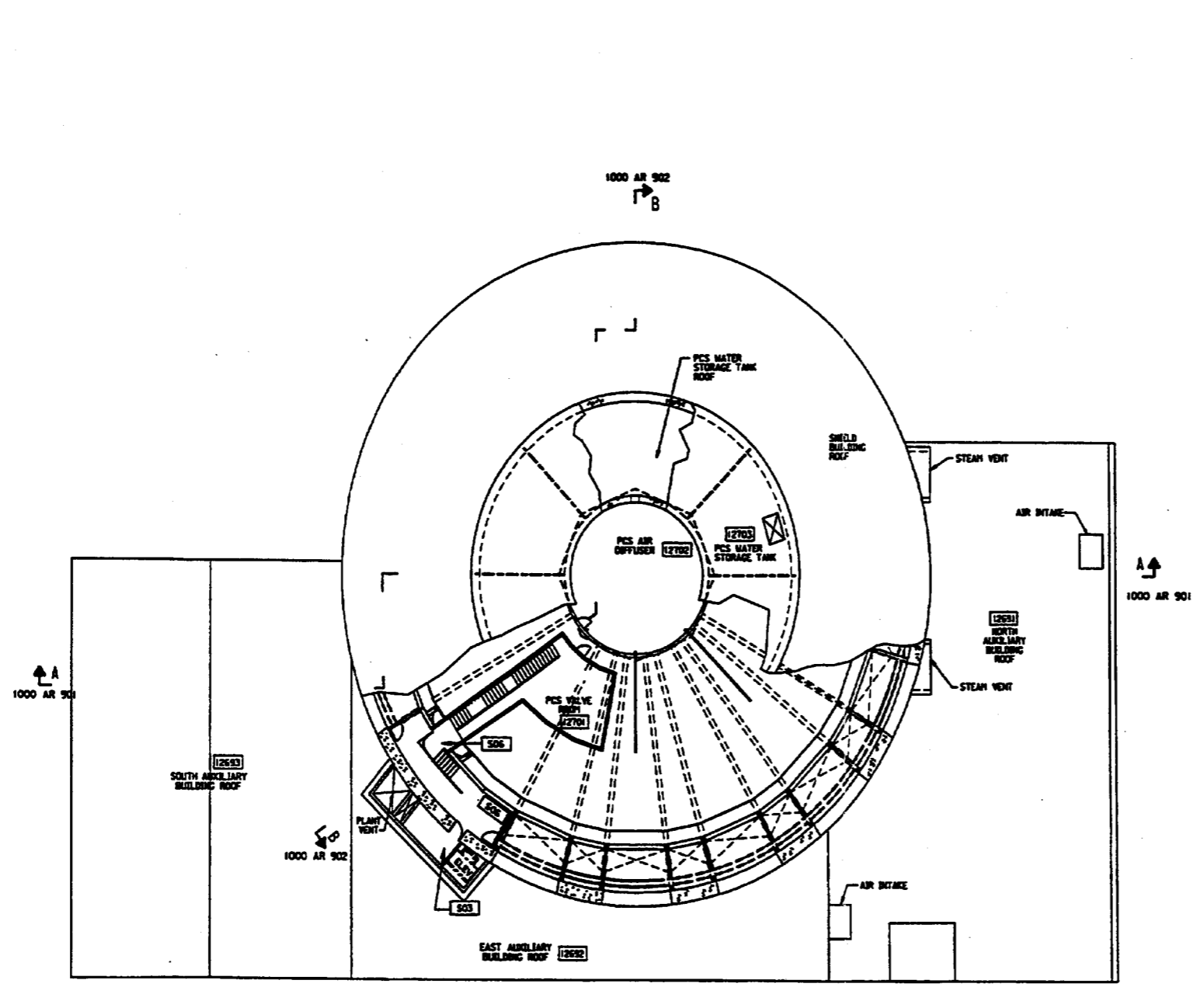

NOTES:

1. THE PURPOSE OF THIS DRAWING IS FOR IDENTIFICATION OF ROOM NUMBERS AND ROOM DESCRIPTIONS ONLY. BACKGROUND INFORMATION MAY CHANGE AND LEGIBILITY OF THE BACKGROUND IS NOT REQUIRED.

Figure 1.2-12

**Nuclear Island General Arrangement
Plan at El. 160'-6" & 180'-0"**

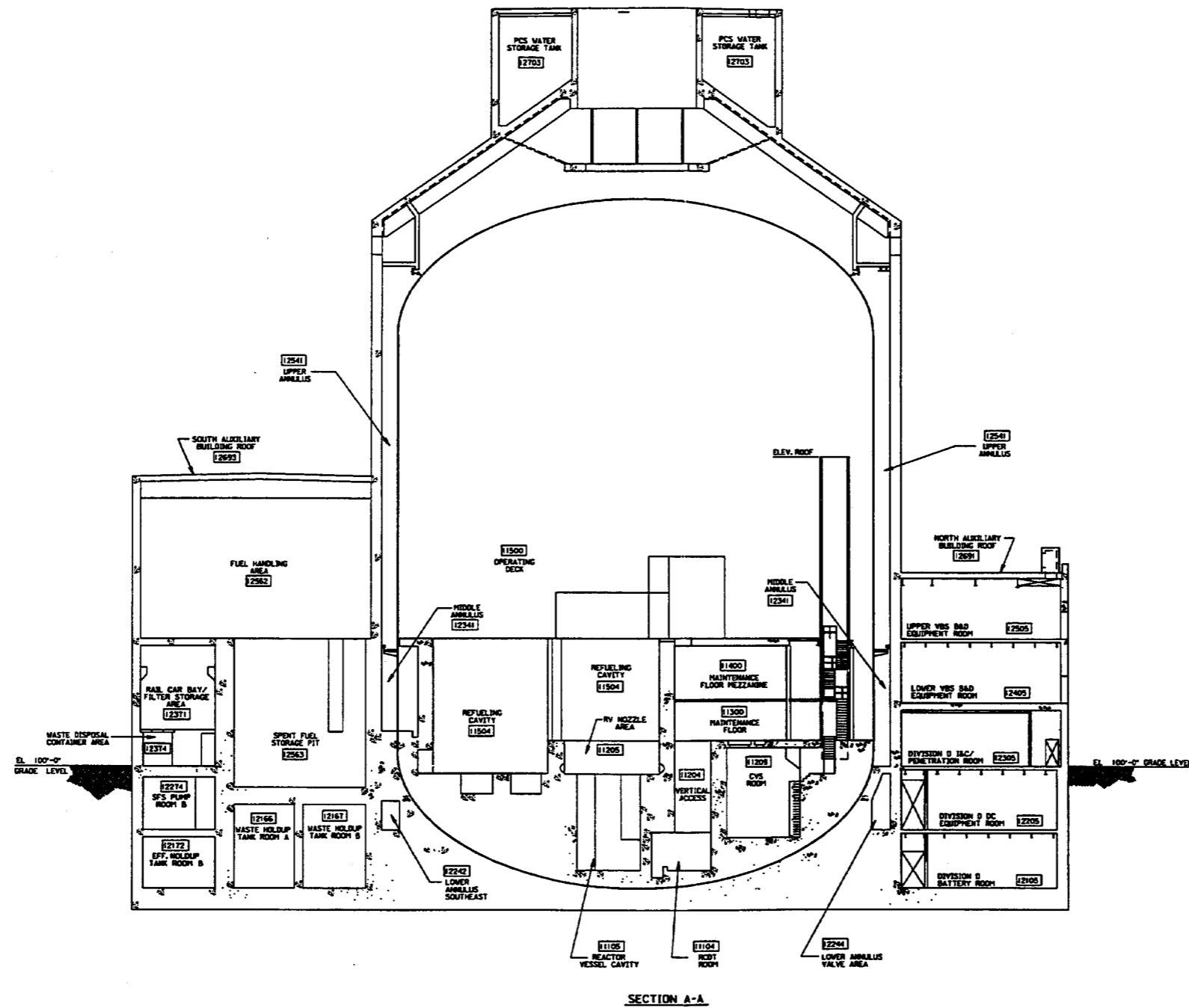

Figure 1.2-13

Nuclear Island General Arrangement
Section A-A

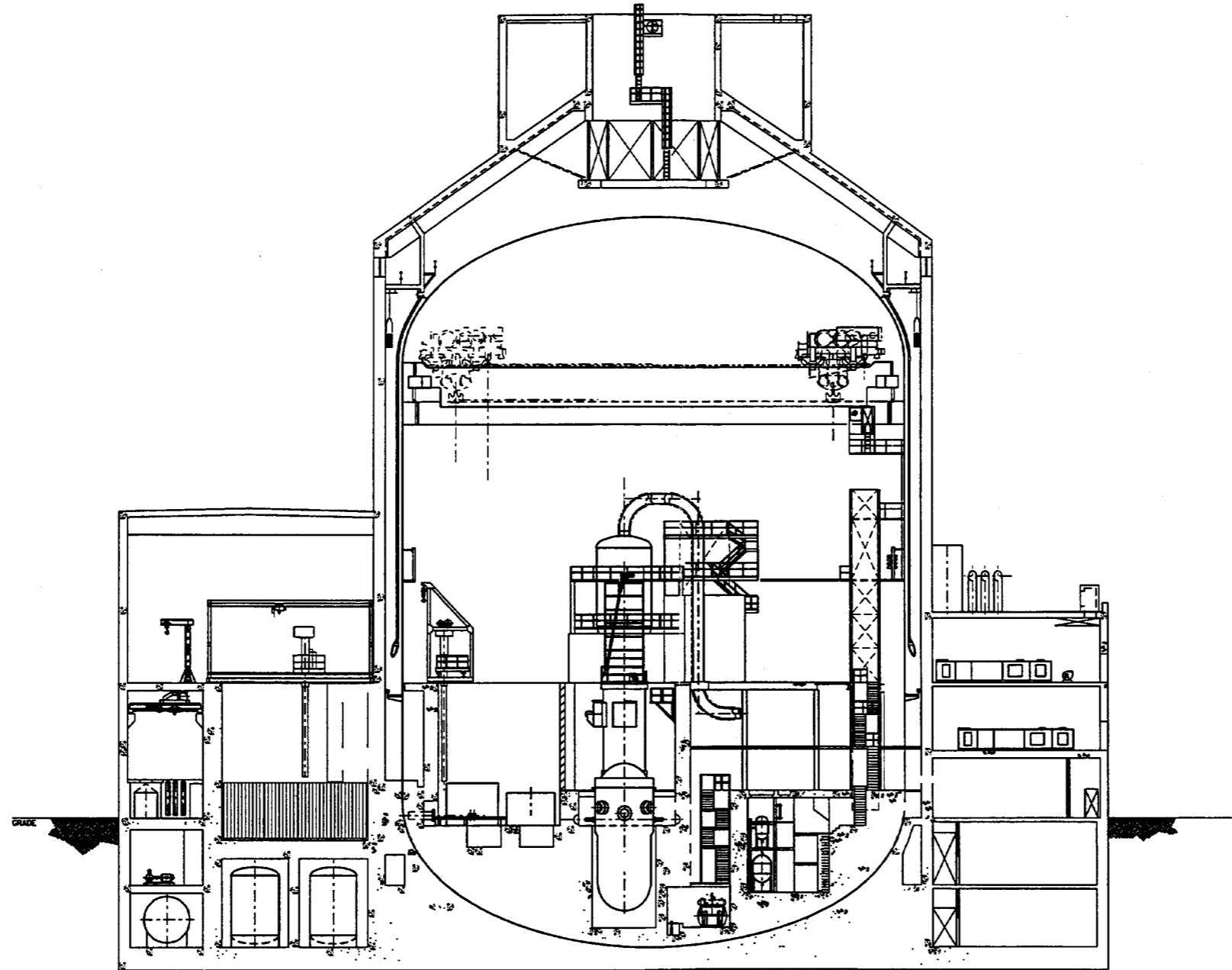

Figure 1.2-14

**Nuclear Island General Arrangement
Section A-A with Equipment**

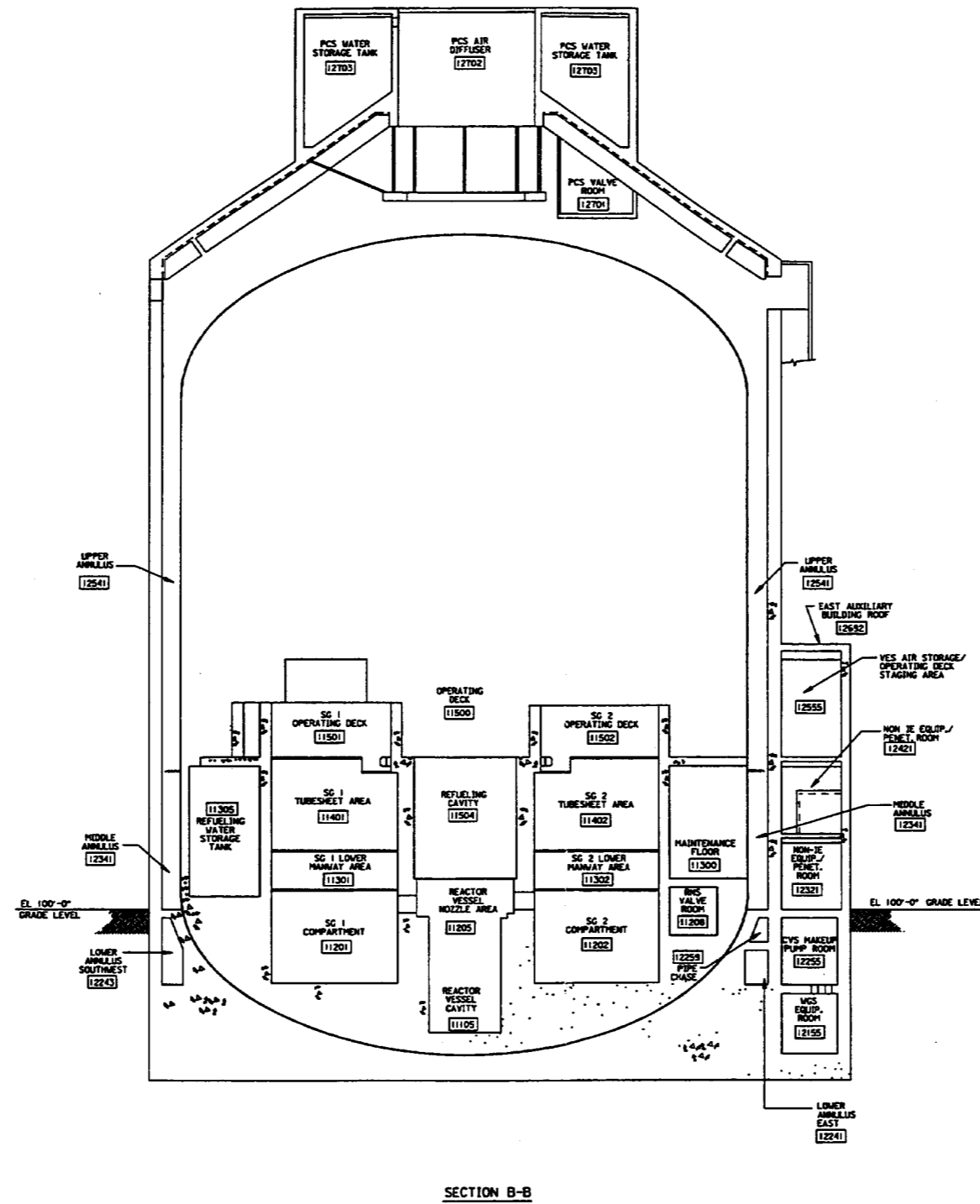

Figure 1.2-15

Nuclear Island General Arrangement
Section B-B

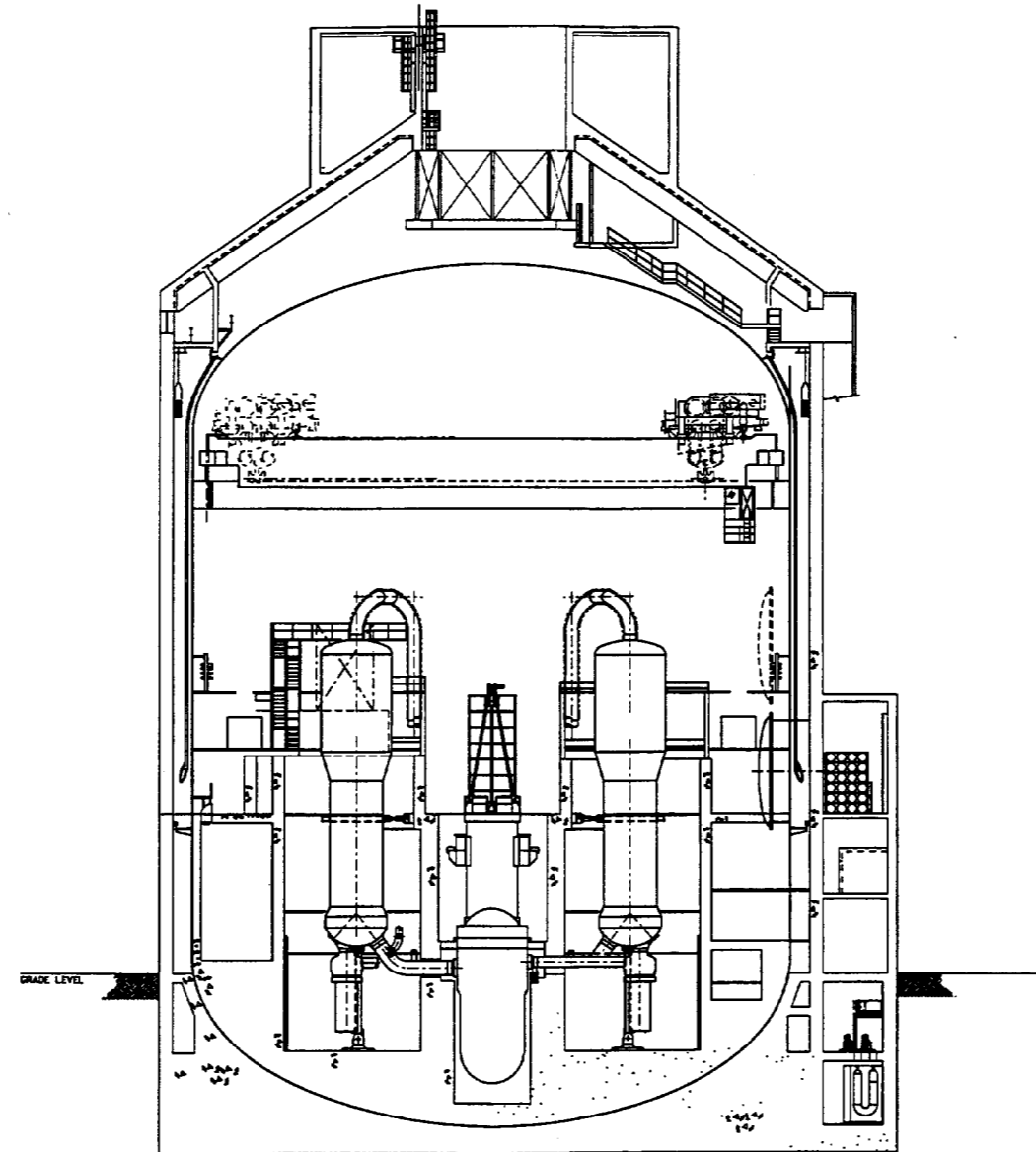

Figure 1.2-16

Nuclear Island General Arrangement
Section B-B with Equipment

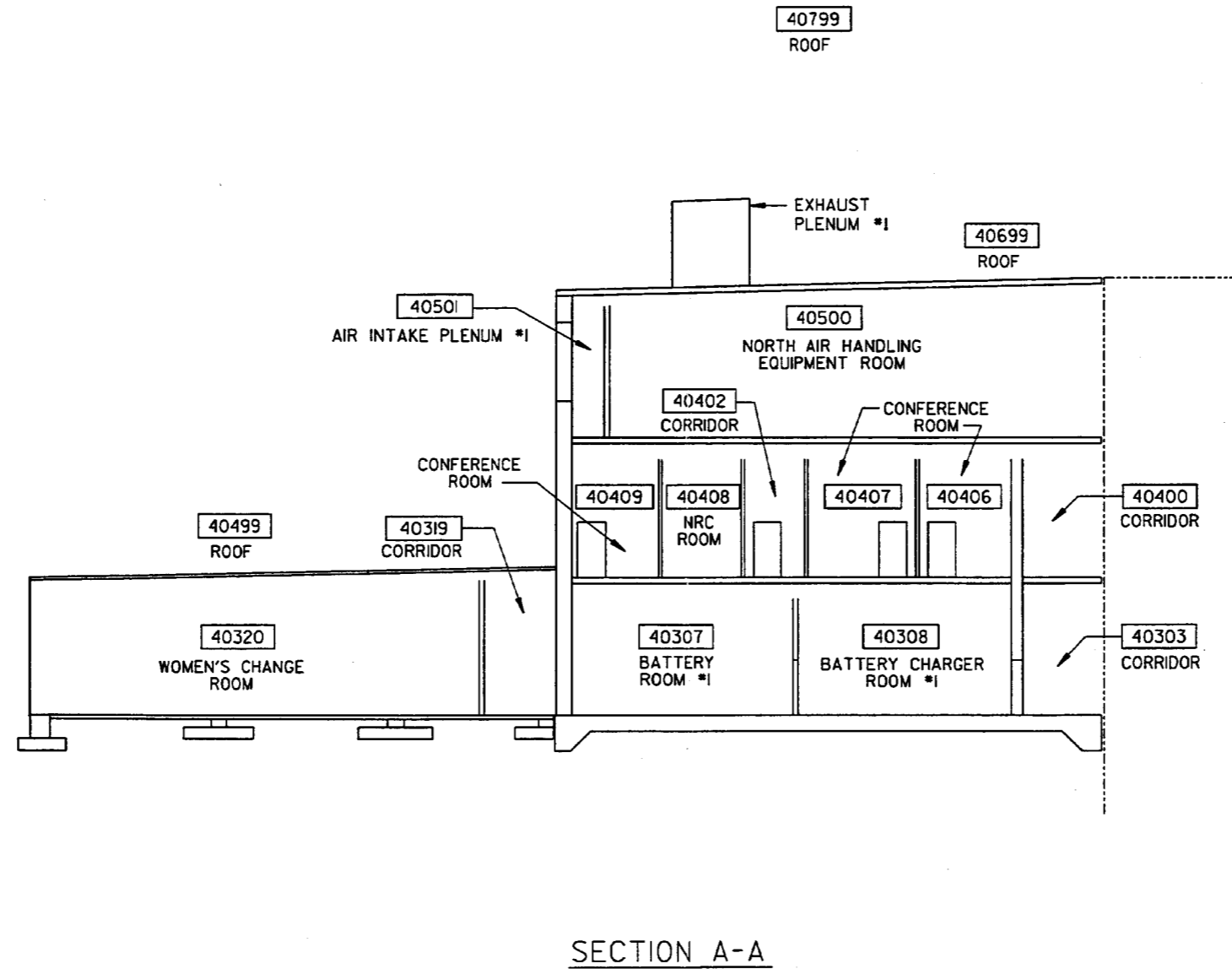

Figure 1.2-17

Annex Building General Arrangement
Section A-A

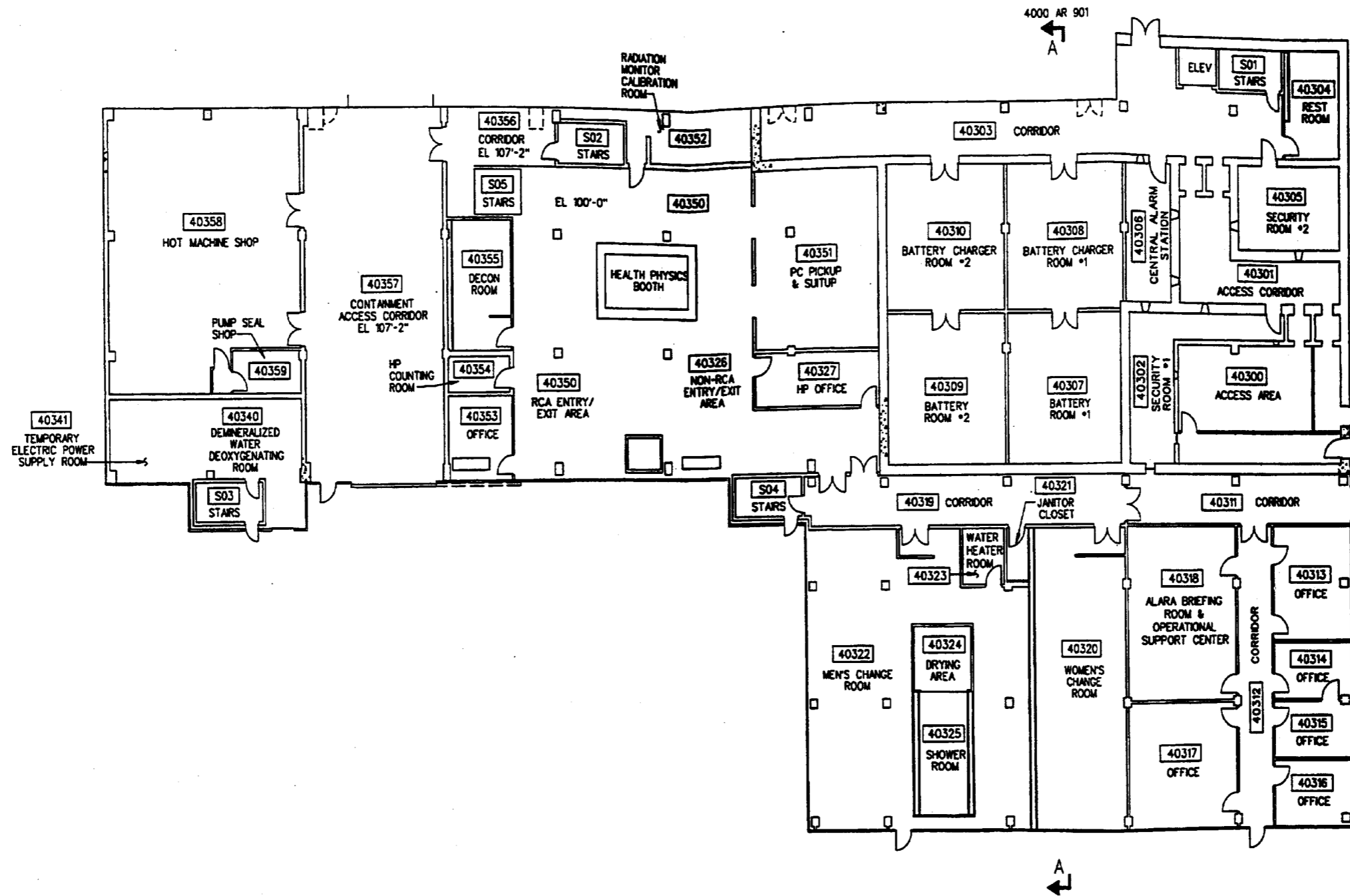
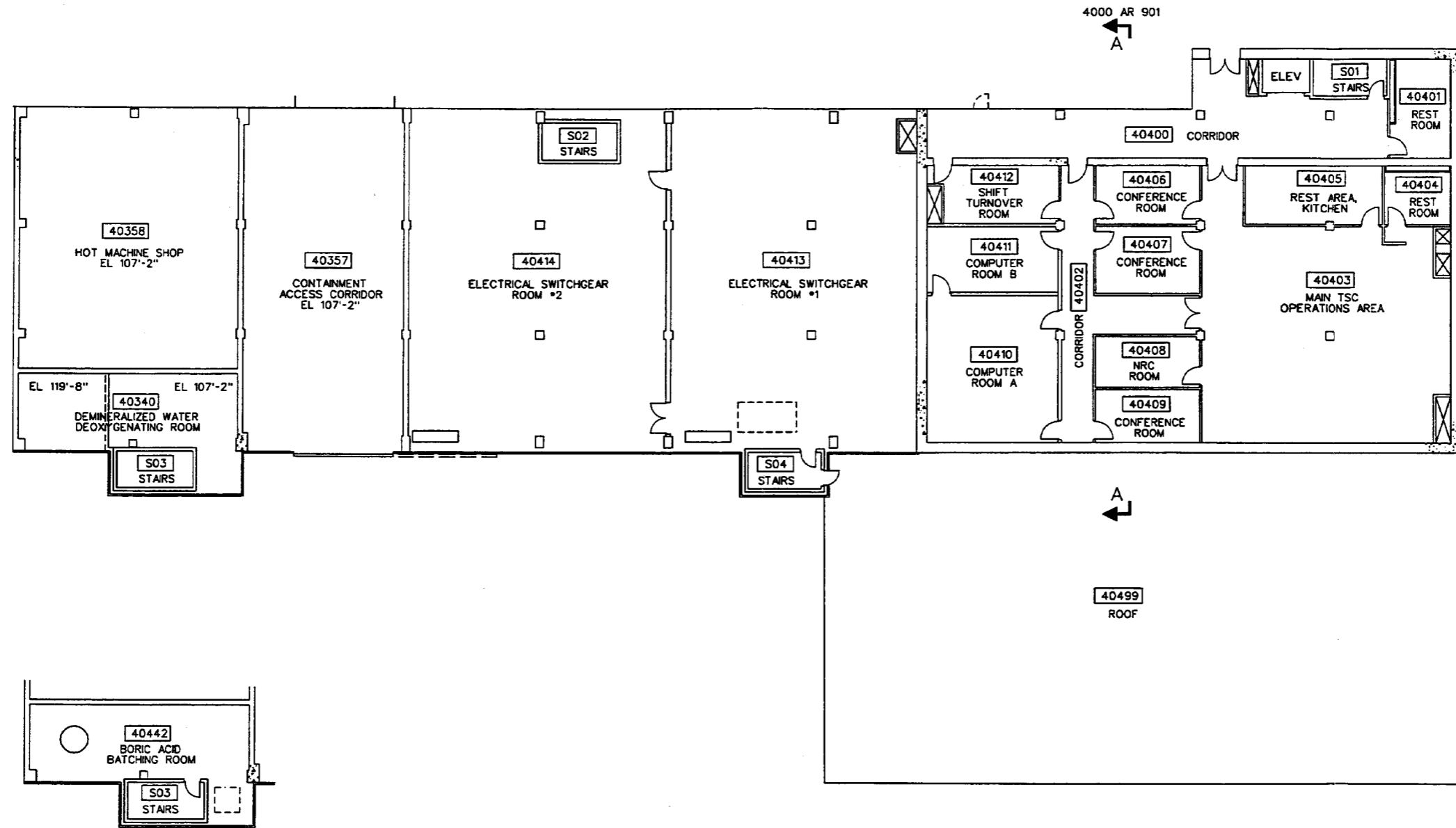

Figure 1.2-18

Annex Building General Arrangement
Plan at Elevation 100'-0" & 107'-2"



PART PLAN EL 126'-3"

Figure 1.2-19

Annex Building General Arrangement
Plan at Elevation 117'-6" & 126'-3"

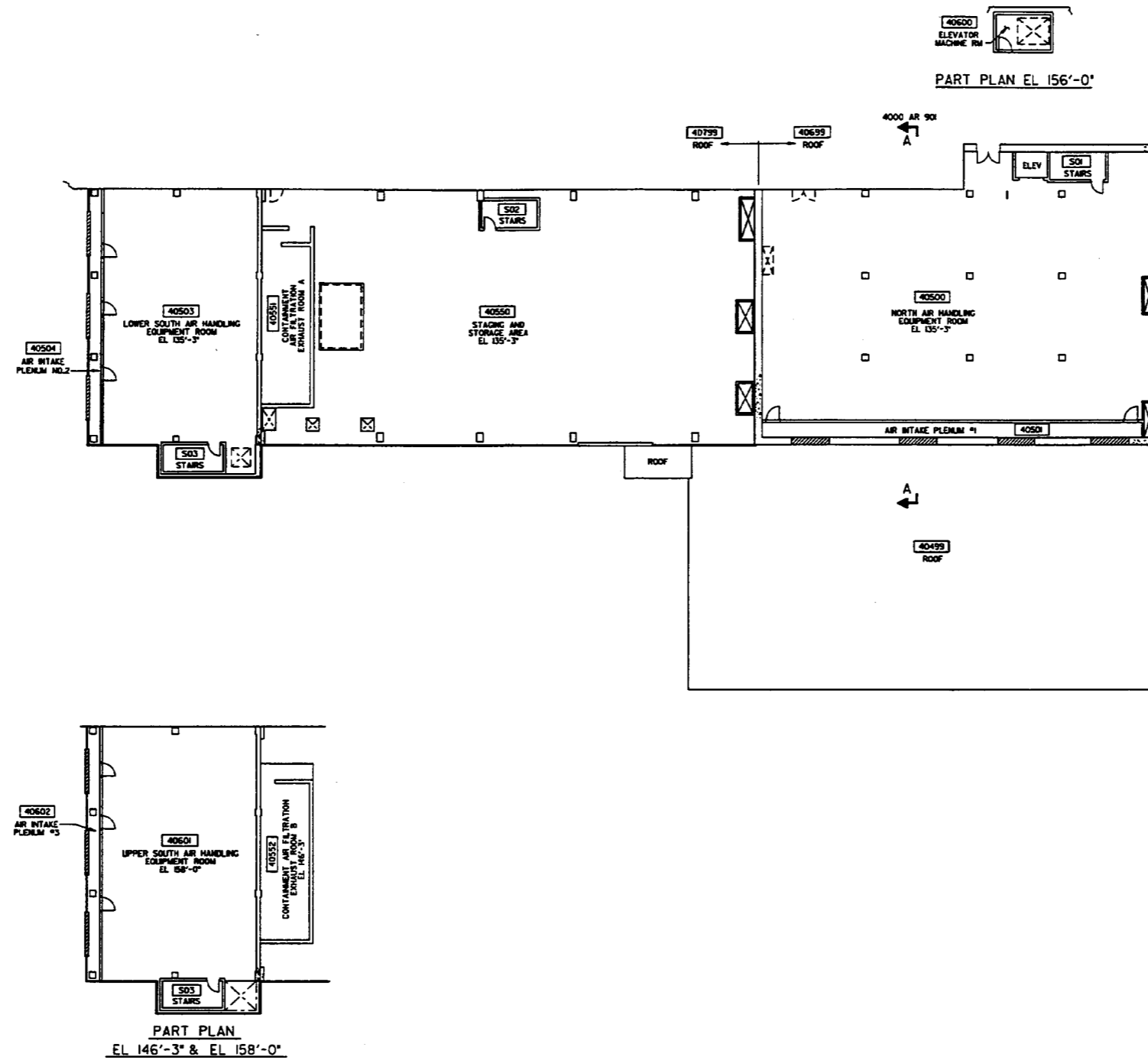

Figure 1.2-20

Annex Building General Arrangement
Plan at Elevation 135'-3", 156'-0", & 158'-0"

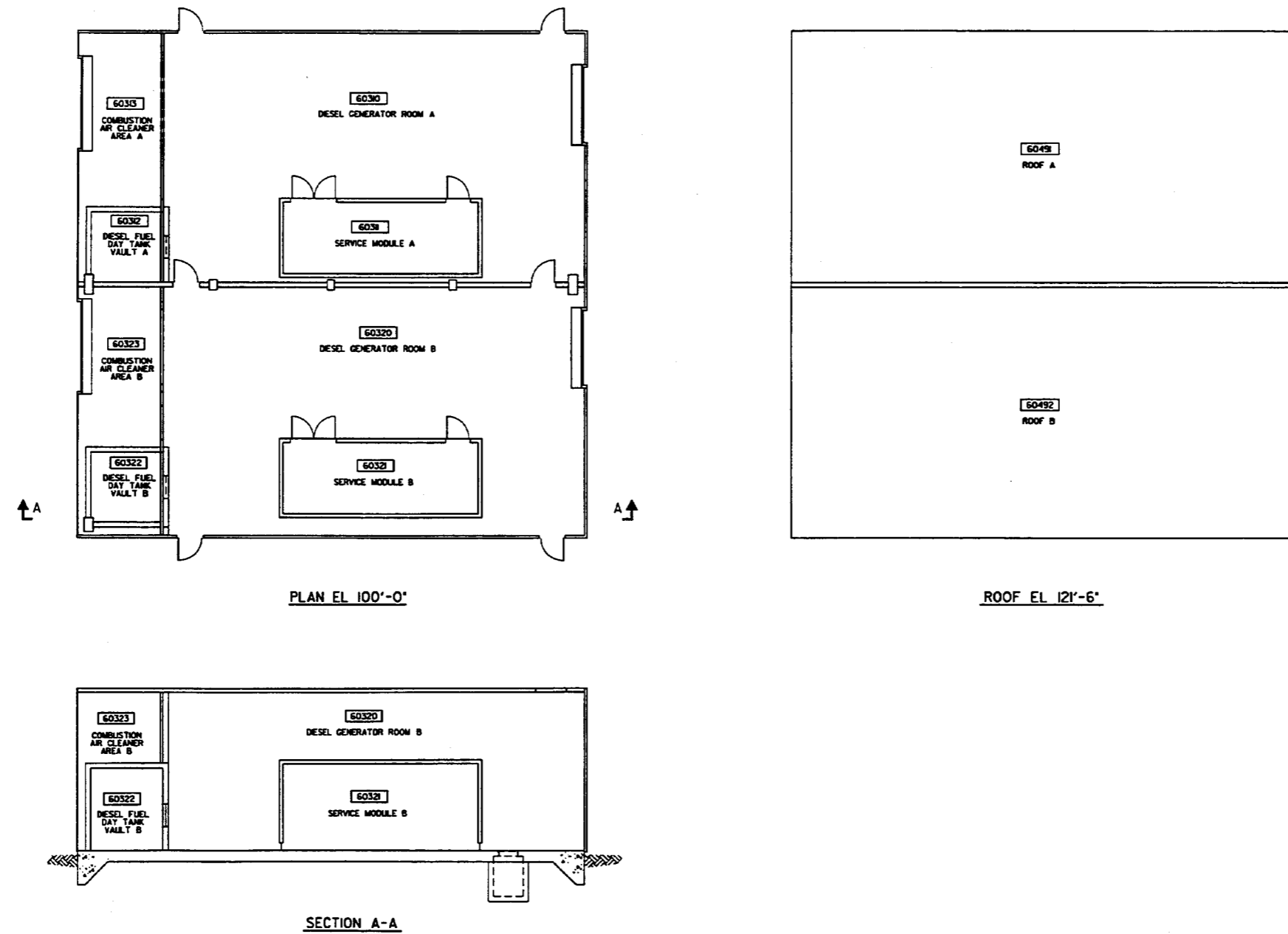

Figure 1.2-21

Diesel Generator Building General Arrangement
Plan at Elevation 100'-0" & Section A-A

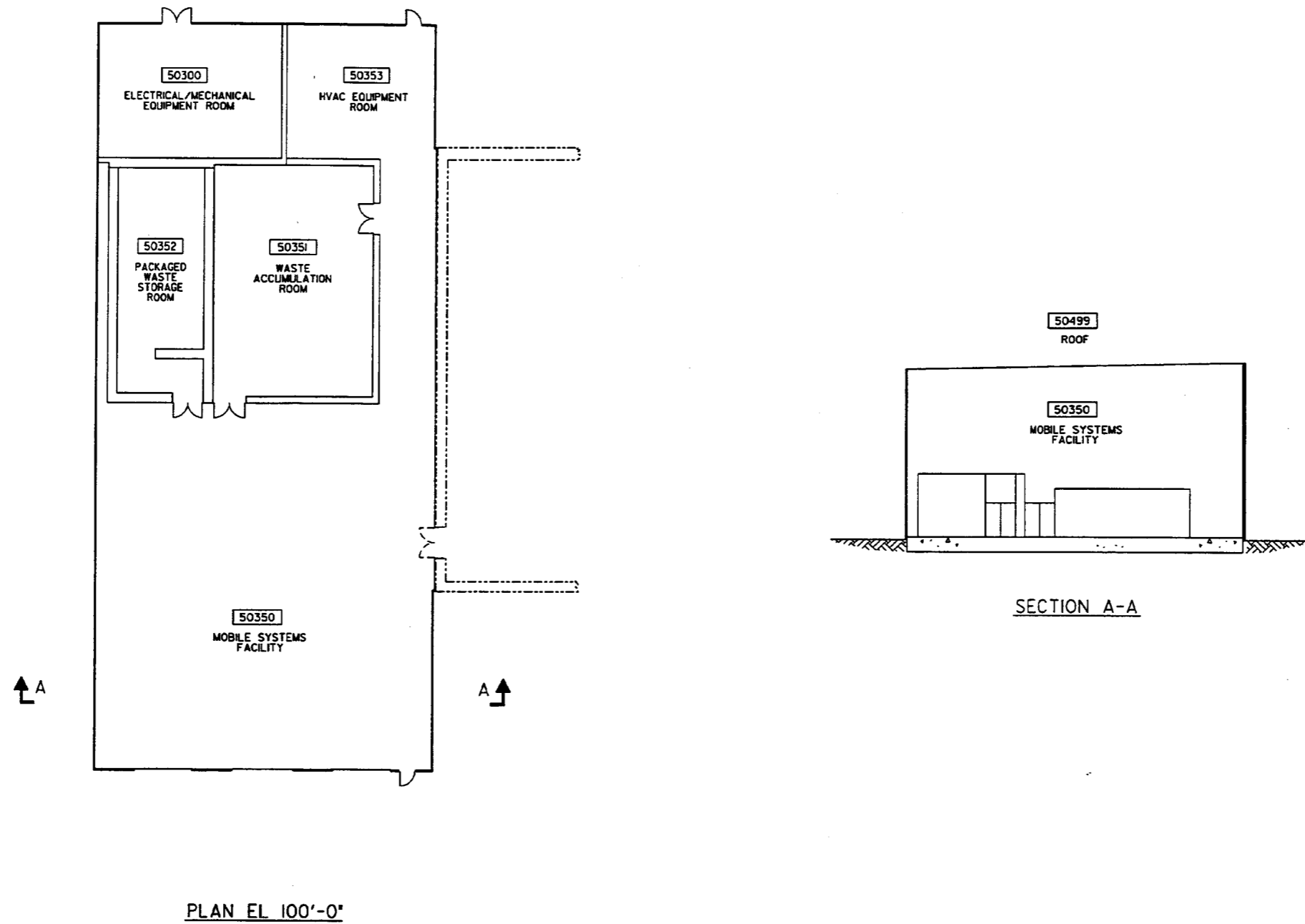

Figure 1.2-22

Radwaste Building General Arrangement
Plan at El. 100'-0"

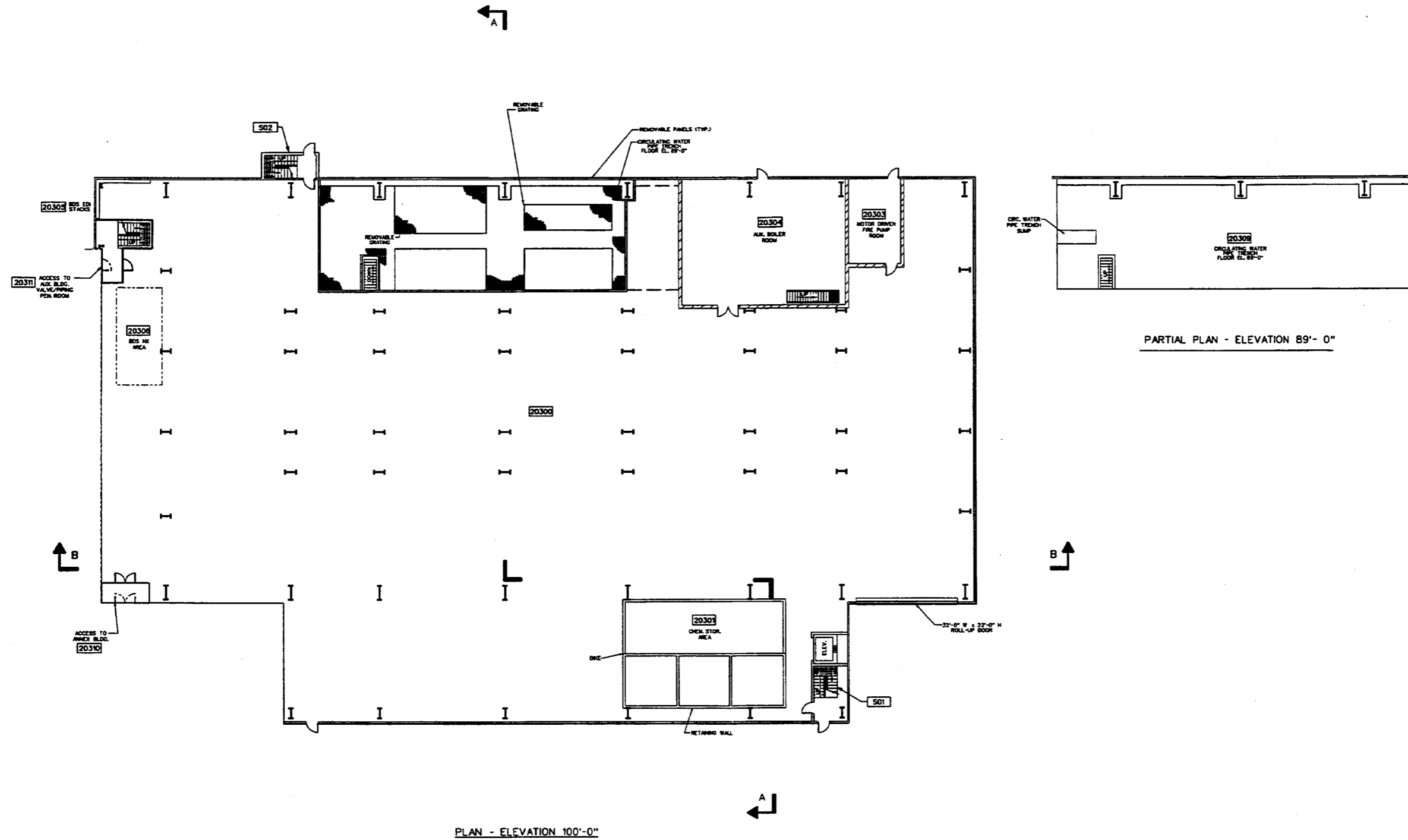

Figure 1.2-23

Turbine Building General Arrangement
Plan at Elevation 89'-0" & 100'-0"

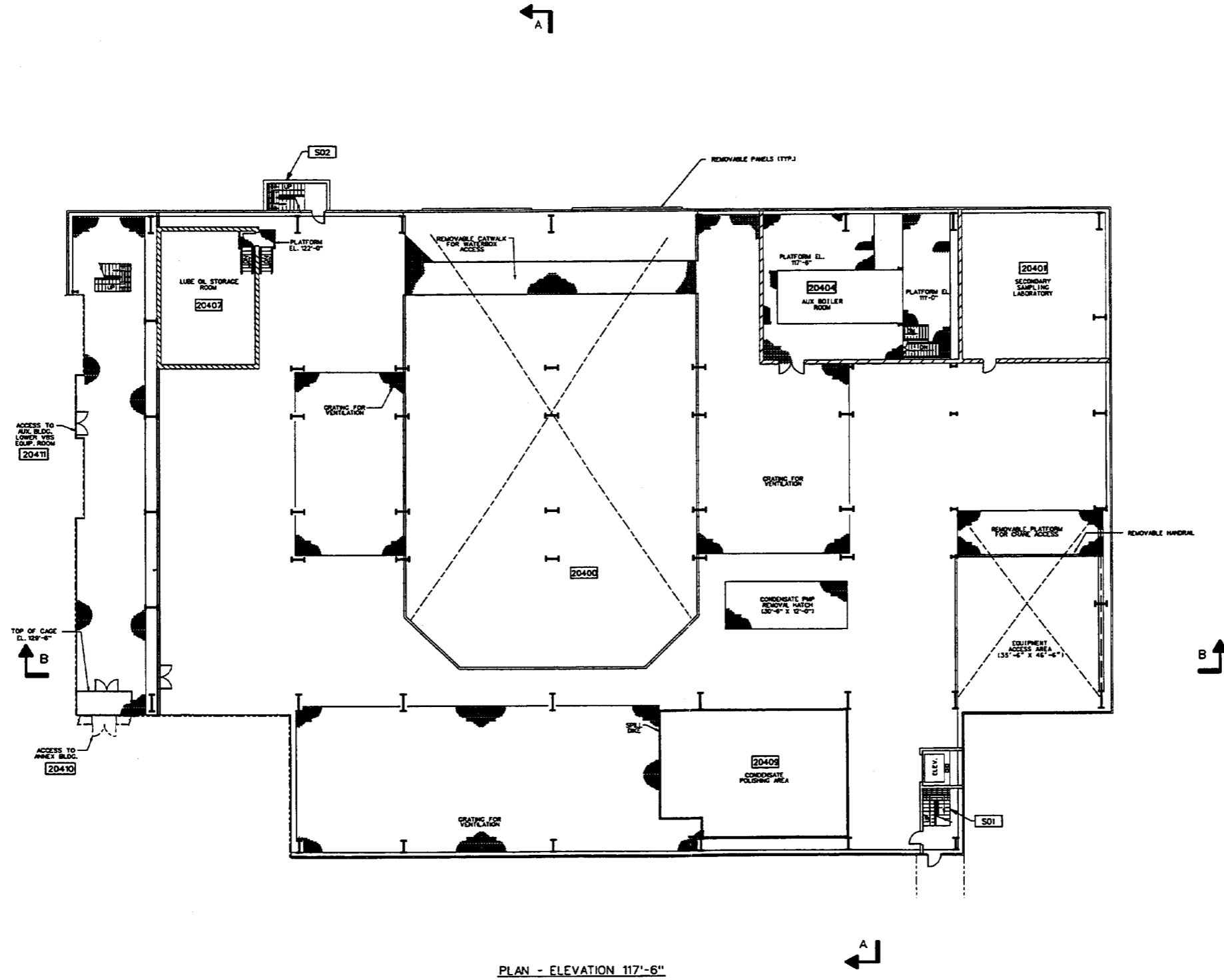

Figure 1.2-24

Turbine Building General Arrangement
Plan at Elevation 117'-6"

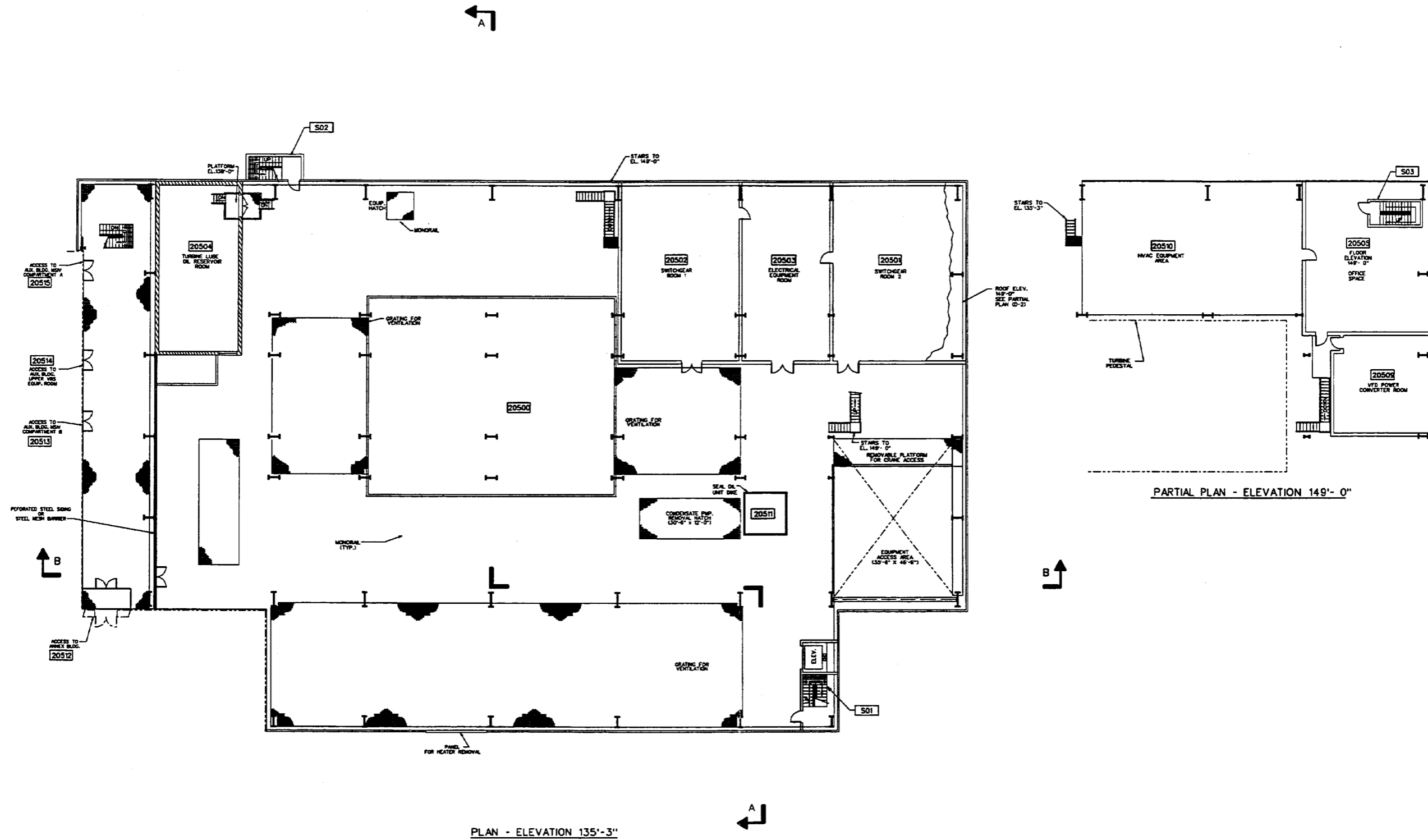

Figure 1.2-25

Turbine Building General Arrangement
Plan at Elevation 135'-3"

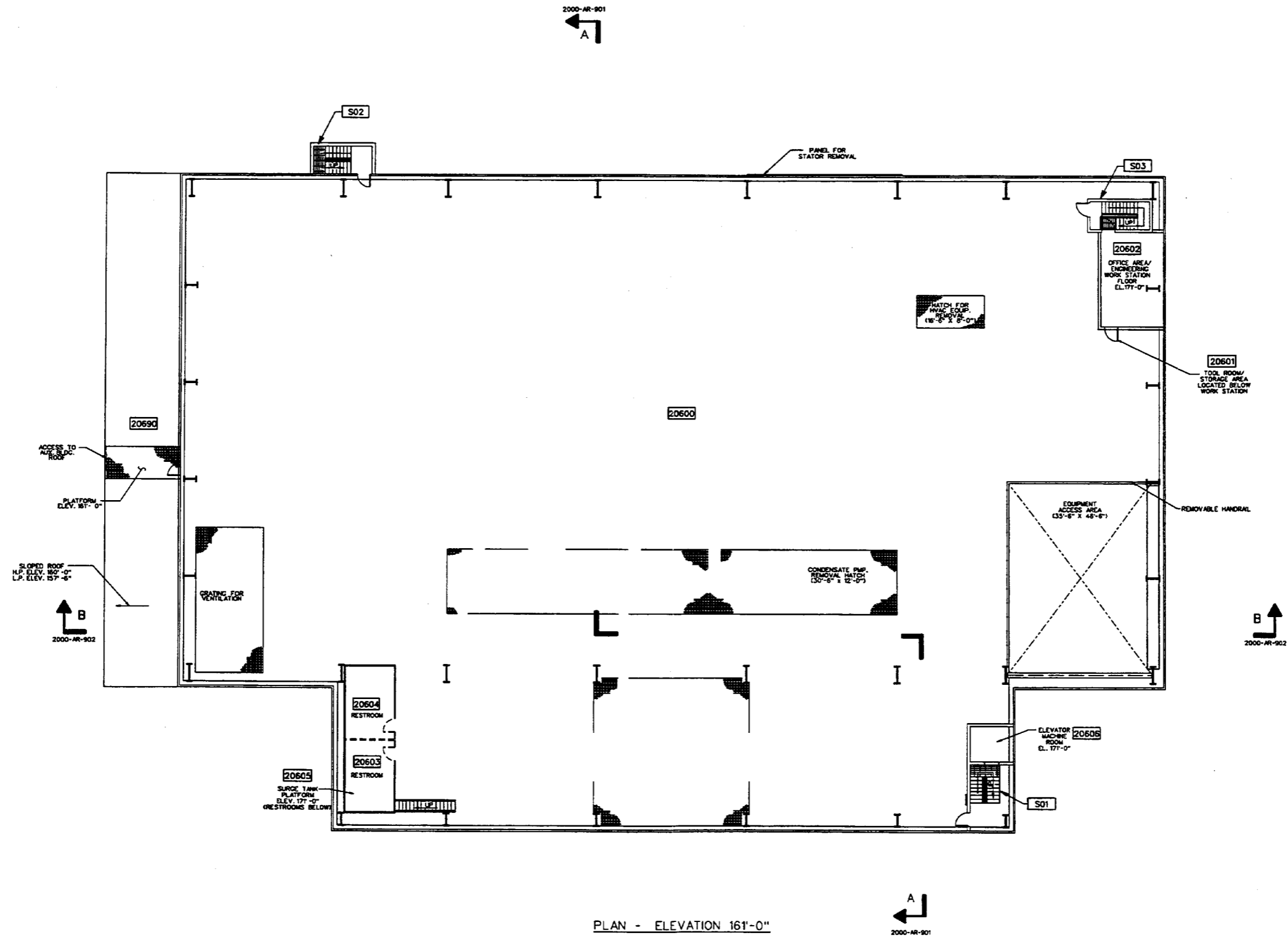

Figure 1.2-26

Turbine Building General Arrangement
Plan at El. 161'-0"

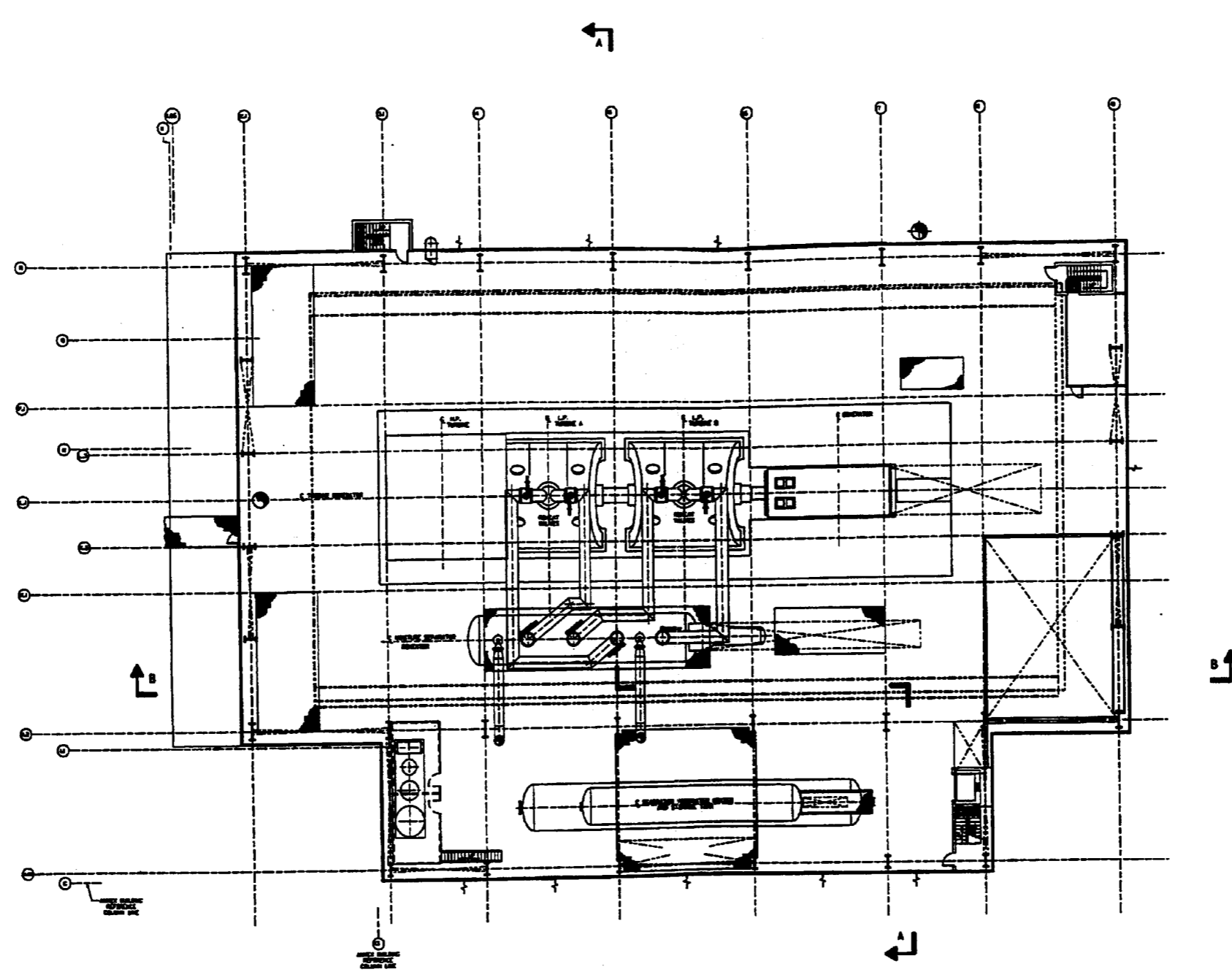

Figure 1.2-27

**Turbine Building General Arrangement
Plan at Elevation 161'-0" with Equipment**

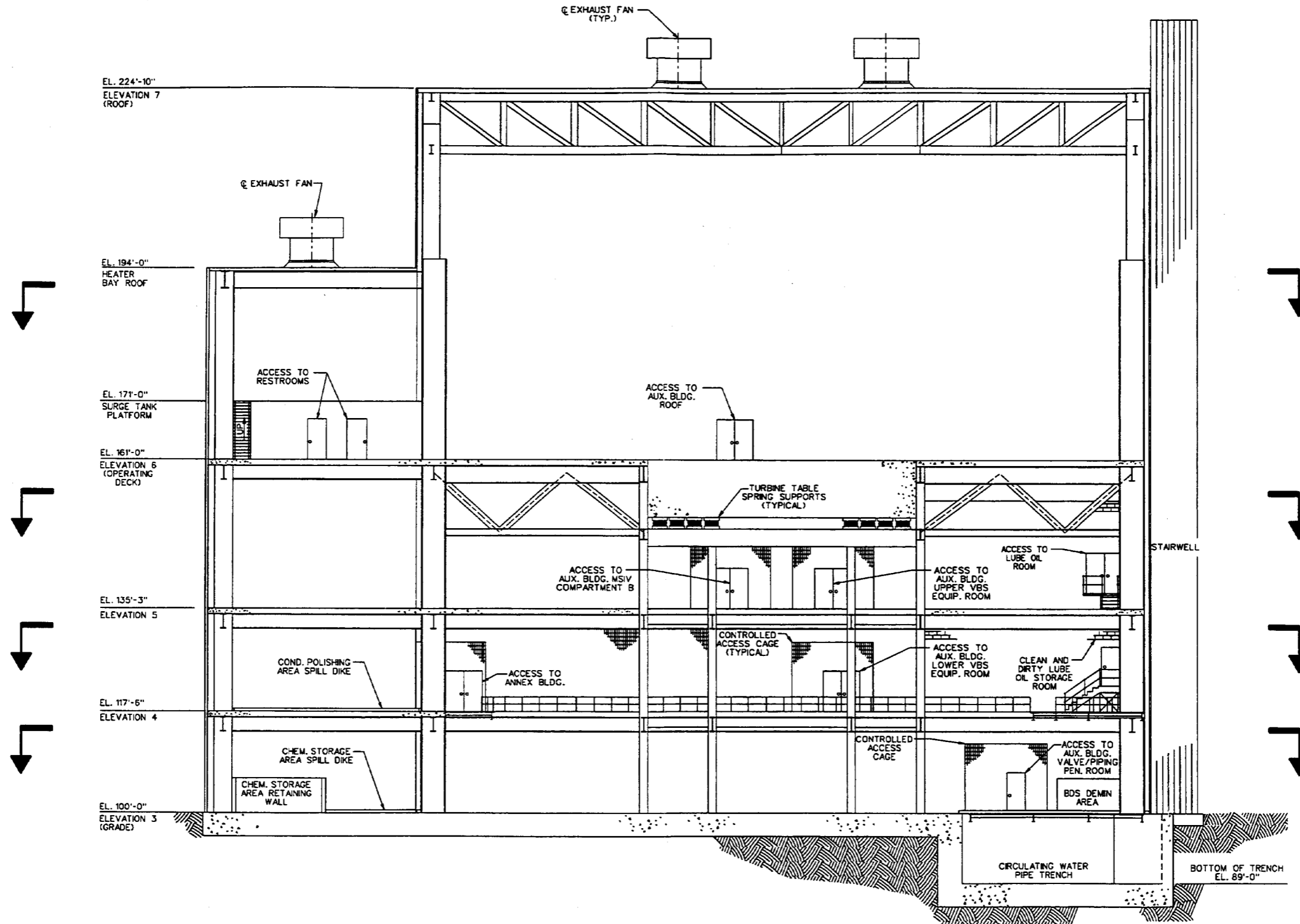

Figure 1.2-29

Turbine Building General Arrangement
Section A-A

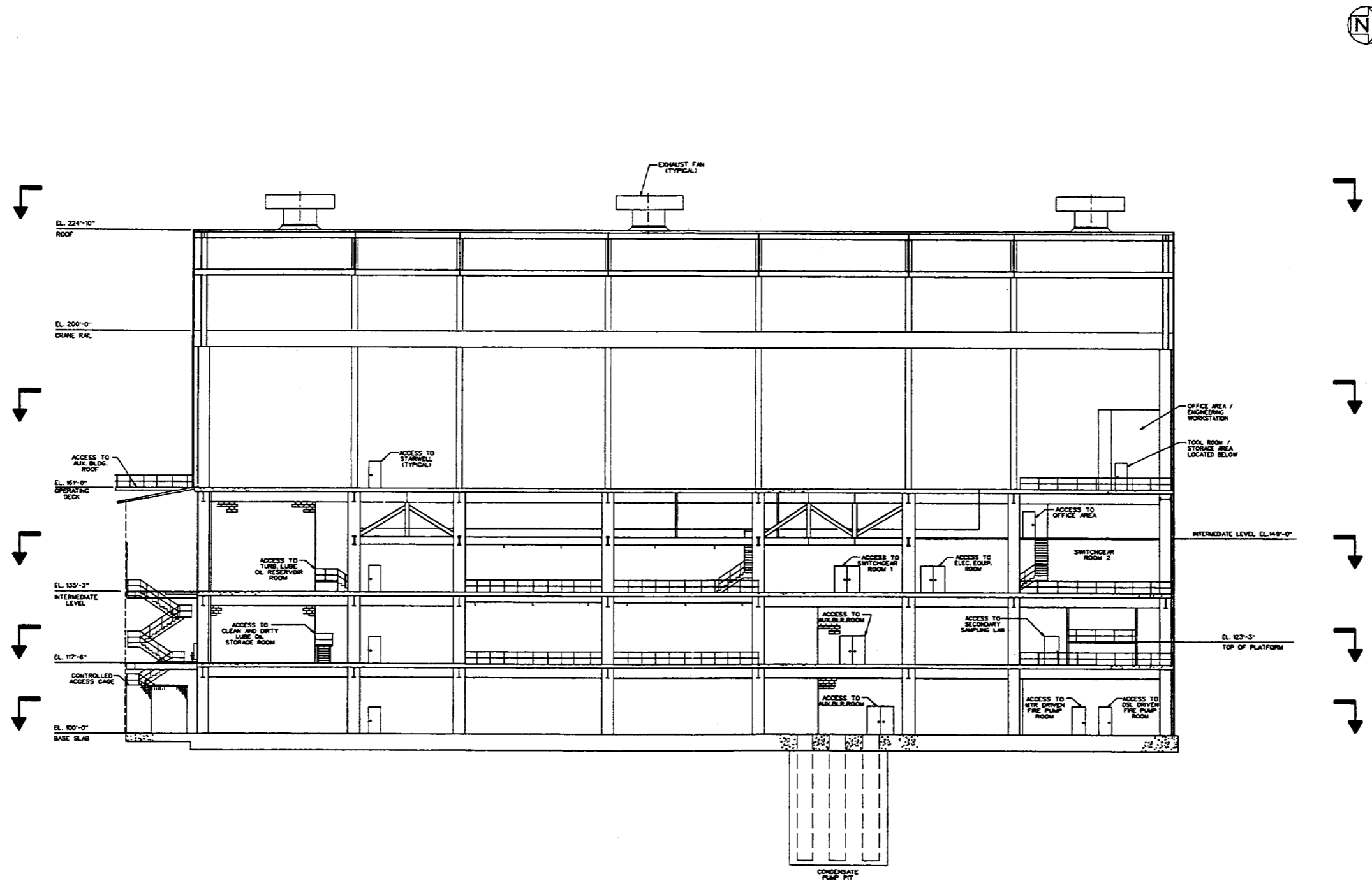

Figure 1.2-30

Turbine Building General Arrangement
Section B-B

[This page intentionally blank]