

Improved Technical Specifications

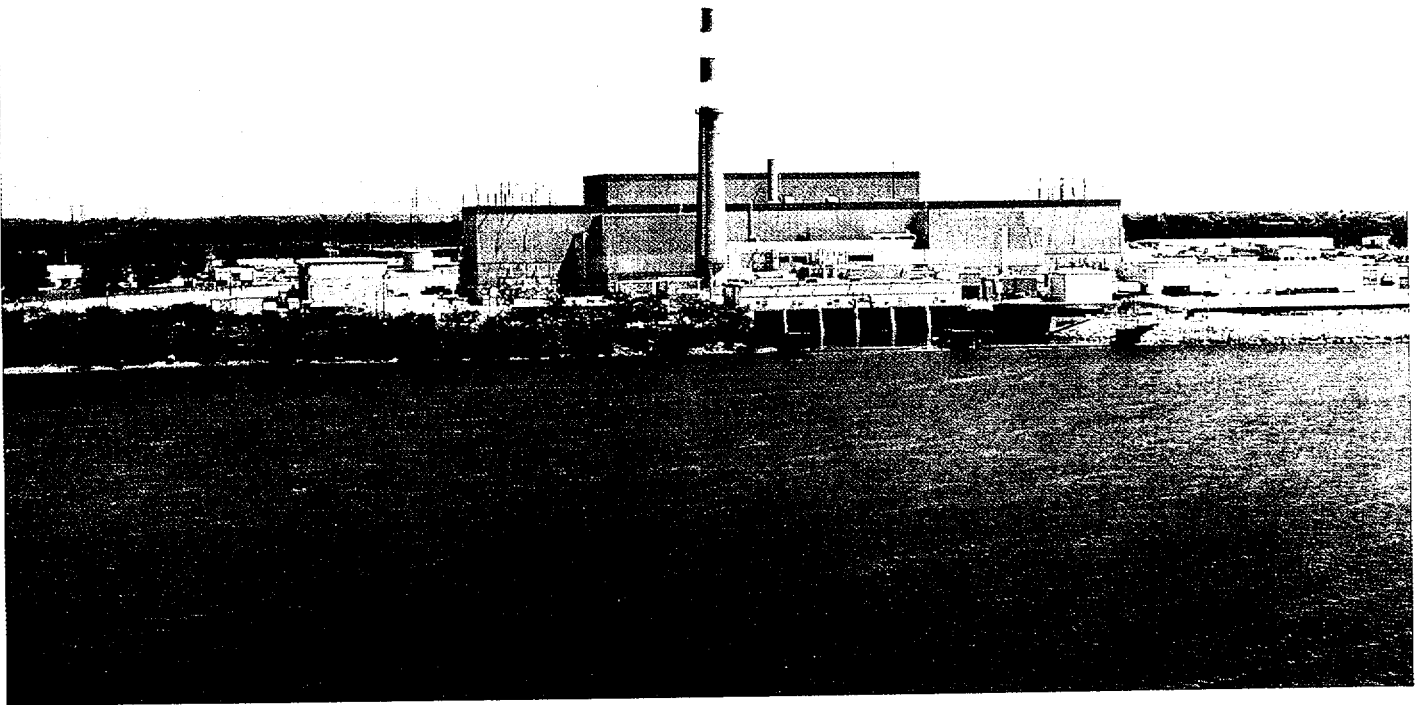

Quad Cities Station

Volume 4:
Section 3.3; ISTS/JFDs, ISTS
Bases/JFDs, and NSHC & EA

<CTS>

3.3 INSTRUMENTATION

3.3.1.1 Reactor Protection System (RPS) Instrumentation

<3.1.A>
<2.2.A>

LCO 3.3.1.1 The RPS instrumentation for each Function in Table 3.3.1.1-1 shall be OPERABLE.

<Appl 3.1.A>
<T 3.1.A-1>
<Appl 2.2..A>

APPLICABILITY: According to Table 3.3.1.1-1.

2. When Functions 2.b and 2.c channels are inoperable due to APRM gain adjustment factor (GAF) not within limits, entry into associated Conditions and Required Actions may be delayed for up to 2 hours if the GAF is ≥ 1.02 , and up to 12 hours if the GAF is < 0.98 .

ACTIONS

NOTE

1. Separate Condition entry is allowed for each channel.

<T 4.1.A-1 footnote d>

CONDITION	REQUIRED ACTION	COMPLETION TIME
<p><3.1.A Act 1> <3.1.A Act 2> A. <3.1.A Act 2.c> <2.2.A Action></p> <p>One or more required channels inoperable.</p>	<p>A.1 Place channel in trip.</p> <p>OR</p> <p>A.2 Place associated trip system in trip.</p>	<p>12 hours</p> <p>12 hours</p>
<p><3.1.A Act 2> <3.1.A Act 2.b> B. <2.2.A Action></p> <p>One or more Functions with one or more required channels inoperable in both trip systems.</p>	<p>B.1 Place channel in one trip system in trip.</p> <p>OR</p> <p>B.2 Place one trip system in trip.</p>	<p>6 hours</p> <p>6 hours</p>
<p><3.1.A Act 2> <3.1.A Act 2.a> C. <3.1.A Act 3> <2.2.A Action></p> <p>One or more Functions with RPS trip capability not maintained.</p>	<p>C.1 Restore RPS trip capability.</p>	<p>1 hour</p>

(continued)

{CTS}

ACTIONS (continued)

CONDITION	REQUIRED ACTION	COMPLETION TIME
<p>{3.1.A Act 2}</p> <p>{3.1.A Act 3}</p> <p>{3.1.A footnote}</p> <p>{2.2.A Action}</p> <p>D. Required Action and associated Completion Time of Condition A, B, or C not met.</p>	<p>D.1 Enter the Condition referenced in Table 3.3.1.1-1 for the channel.</p>	<p>Immediately</p>
<p>{T 3.1.A-1}</p> <p>{ACTION 16}</p> <p>{2.2.A Action}</p> <p>E. As required by Required Action D.1 and referenced in Table 3.3.1.1-1.</p>	<p>E.1 Reduce THERMAL POWER to 30% RTP.</p> <p style="text-align: center;">(45) — [1]</p>	<p>4 hours</p>
<p>{T 3.1.A-1}</p> <p>{ACTION 14}</p> <p>{2.2.A Action}</p> <p>F. As required by Required Action D.1 and referenced in Table 3.3.1.1-1.</p>	<p>F.1 Be in MODE 2.</p>	<p>8 hours</p> <p style="text-align: center;">(8) — [2]</p>
<p>{T 3.1.A-1}</p> <p>{ACTION 11}</p> <p>{2.2.A Action}</p> <p>G. As required by Required Action D.1 and referenced in Table 3.3.1.1-1.</p>	<p>G.1 Be in MODE 3.</p>	<p>12 hours</p>
<p>{T 3.1.A-1}</p> <p>{ACTION 13}</p> <p>{T 3.1.A-1}</p> <p>{ACTION 19}</p> <p>{2.2.A Action}</p> <p>H. As required by Required Action D.1 and referenced in Table 3.3.1.1-1.</p>	<p>H.1 Initiate action to fully insert all insertable control rods in core cells containing one or more fuel assemblies.</p>	<p>Immediately</p>

<CTS>

SURVEILLANCE REQUIREMENTS

NOTES

- 1. Refer to Table 3.3.1.1-1 to determine which SRs apply for each RPS Function.
- 2. When a channel is placed in an inoperable status solely for performance of required Surveillances, entry into associated Conditions and Required Actions may be delayed for up to 6 hours provided the associated Function maintains RPS trip capability.

SURVEILLANCE	FREQUENCY
SR 3.3.1.1.1 Perform CHANNEL CHECK.	12 hours
SR 3.3.1.1.2 -----NOTE----- Not required to be performed until 12 hours after THERMAL POWER ≥ 25% RTP. ----- Verify the absolute difference between the average power range monitor (APRM) channels and the calculated power is ≤ 2% RTP plus any gain adjustment required by LCO 3.2.4, "Average Power Range Monitor (APRM) Setpoint" while operating at ≥ 25% RTP.	7 days
SR 3.3.1.1.3 Adjust the channel to conform to a calibrated flow signal.	7 days
SR 3.3.1.1.4 -----NOTE----- Not required to be performed when entering MODE 2 from MODE 1 until 24 hours after entering MODE 2. ----- Perform CHANNEL FUNCTIONAL TEST.	7 days

<4.1.A.1>
<T. 3.1.A-1 footnote a>

<T 4.1.A-1>

<T 4.1.A-1 footnote d>

<T 4.1.A-1 footnote e>

<T 4.1.A-1 footnote c>

<T 4.1.A-1 footnote o>

Gain and

2

24

11

(continued)

TSTF-264 changes not adopted

16

(CTS)

RPS Instrumentation 3.3.1.1

a functional test of each RPS automatic scram contactor

3

SURVEILLANCE REQUIREMENTS (continued)

SURVEILLANCE

FREQUENCY

(T 4.1.A-1 footnote c)

SR 3.3.1.1.5 Perform CHANNEL FUNCTIONAL TEST.

7 days

(T 4.1.A-1 footnote b)

SR 3.3.1.1.6 Verify the source range monitor (SRM) and intermediate range monitor (IRM) channels overlap.

Prior to withdrawing SRMs from the fully inserted position

fully

11

(T 4.1.A-1 footnote b)

SR 3.3.1.1.7 NOTE Only required to be met during entry into MODE 2 from MODE 1.

Verify the IRM and APRM channels overlap.

7 days

4

2000 effective full power hours

(T 4.1.A-1 footnote f)

SR 3.3.1.1.8 Calibrate the local power range monitors.

1000 MWD average core exposure

3

3

(T 4.1.A-1)

SR 3.3.1.1.9 Perform CHANNEL FUNCTIONAL TEST.

92 days

10

3

11

(T 4.1.A-1 footnote h)

SR 3.3.1.1.10 Calibrate the trip units.

92 days

11

11

(continued)

(T 4.1.A-1)

Insert SR 3.3.1.1.8

12

Insert SR 3.3.1.1.12

5

<CTS>

12

INSERT SR 3.3.1.1.8

SR 3.3.1.1.8	Perform CHANNEL FUNCTIONAL TEST.	31 days
--------------	----------------------------------	---------

<T 4.1.A-1>

5

INSERT SR 3.3.1.1.12

<T 4.1.A-1>

SR 3.3.1.1.12	Perform CHANNEL CALIBRATION.	92 days
---------------	------------------------------	---------

(CTS) Insert from page 3.3-6 [17]

SURVEILLANCE REQUIREMENTS (continued)

SURVEILLANCE	FREQUENCY
<p>SR 3.3.1.1.10</p> <p>NOTES</p> <ol style="list-style-type: none"> 1. Neutron detectors are excluded. 2. For Function 2.a, not required to be performed when entering MODE 2 from MODE 1 until 22 hours after entering MODE 2. <p>Perform CHANNEL CALIBRATION.</p>	<p>[2]</p> <p>184 days</p>
<p>SR 3.3.1.1.10</p> <p>Perform CHANNEL FUNCTIONAL TEST.</p>	<p>[1]</p> <p>[18] months</p>
<p>SR 3.3.1.1.10</p> <p>NOTES</p> <ol style="list-style-type: none"> 1. Neutron detectors are excluded. 2. For Function 1, not required to be performed when entering MODE 2 from MODE 1 until 2 hours after entering MODE 2. <p>Perform CHANNEL CALIBRATION.</p>	<p>[1]</p> <p>[18] months</p>
<p>SR 3.3.1.1.10</p> <p>Verify the APRM Flow Biased Simulated Thermal Power—High time constant is ≤ [7] seconds.</p>	<p>[6]</p> <p>[18] months</p>
<p>SR 3.3.1.1.10</p> <p>Perform LOGIC SYSTEM FUNCTIONAL TEST.</p>	<p>[1]</p> <p>[18] months</p>

(T 4.1.A-1 footnote a)
(T 4.1.A-1 footnote o)
(T 4.1.A-1)

3. For Function 2.b, not required for the flow portion of the channels.

(T 4.1.A-1)

(T 4.1.A-1 footnote a)

(T 4.1.A-1 footnote h)
(T 4.1.A-1 footnote o)
(T 4.1.A-1)

(4.1.A.2)

(continued)

(KTS)

move to page 33-5 as indicated [17]

SURVEILLANCE REQUIREMENTS (continued)

SURVEILLANCE	FREQUENCY
<p>SR 3.3.1.1.1. ⁽¹³⁾ Verify Turbine Stop Valve—Closure and Turbine Control Valve Fast Closure, Trip Oil Pressure—Low Functions are not bypassed when THERMAL POWER is \geq ⁽⁴⁵⁾ 100 RTP. [1]</p>	<p>18 months 92 days [1]</p>
<p>SR 3.3.1.1.1. ⁽¹⁸⁾ <u>NOTES</u></p> <ol style="list-style-type: none"> 1. Neutron detectors are excluded. 2. For Function 5 "n" equals 4 channels for the purpose of determining the STAGGERED TEST BASIS Frequency. <p>Verify the RPS RESPONSE TIME is within limits.</p>	<p>[6] ⁽²⁴⁾ 18 months on a STAGGERED TEST BASIS [1]</p>

{DOC M.3}

{DOC L.1}

{DOC A.7}

{4.1.A.3}

TSTF-264
changes not
adopted

RPS Instrumentation
3.3.1.1

Table 3.3.1.1-1 (page 1 of 3)
Reactor Protection System Instrumentation

<CTS>
<T.3.1.A-1>
<T.4.1.A-1>
<T.2.2.A-1>

FUNCTION	APPLICABLE MODES OR OTHER SPECIFIED CONDITIONS	REQUIRED CHANNELS PER TRIP SYSTEM	CONDITIONS REFERENCED FROM REQUIRED ACTION D.1	SURVEILLANCE REQUIREMENTS	ALLOWABLE VALUE
1. Intermediate Range Monitors					
a. Neutron Flux - High	5(a)	X3X	G	SR 3.3.1.1.1 [$\leq \times 120/125$ divisions of full scale]	1
			H	SR 3.3.1.1.4 [$\leq \times 120/125$ divisions of full scale]	1
b. Inop	2 5(a)	X3X	G	SR 3.3.1.1.4 NA	17
			H	SR 3.3.1.1.8 NA	3
2. Average Power Range Monitors					
a. Neutron Flux - High, Setdown	2	X2X	G	SR 3.3.1.1.1 [$\leq \times 20\%$ RTP]	3
				SR 3.3.1.1.4	3
				SR 3.3.1.1.7	3
				SR 3.3.1.1.8	3
				SR 3.3.1.1.9	5
				SR 3.3.1.1.10	6
b. Flow Biased Simulated ^{Neutron Flux} Thermal Power - High	1	X2X	F	SR 3.3.1.1.1 [$\leq \times 0.58$ W]	1
				SR 3.3.1.1.2 [$\leq \times 0.58$ W + 62% RTP and $\leq \times 116.5\%$ RTP(b)]	1
				SR 3.3.1.1.3	10
				SR 3.3.1.1.4	14
				SR 3.3.1.1.5	17
				SR 3.3.1.1.6	17
				SR 3.3.1.1.7	17
				SR 3.3.1.1.8	17
				SR 3.3.1.1.9	17
				SR 3.3.1.1.10	17

(a) With any control rod withdrawn from a core cell containing one or more fuel assemblies.

(b) $\times 0.58$ W + $\times 0.58$ RTP when reset for single loop operation per LCO 3.4.1, "Recirculation Loops Operating."

and $\leq 116.5\%$ RTP

Table 3.3.1.1-1 (page 2 of 3)
Reactor Protection System Instrumentation

<CTS>
<T. 3.1.A-1>
<T. 4.1.A-1>
<T. 2.2.A-1>

FUNCTION	APPLICABLE MODES OR OTHER SPECIFIED CONDITIONS	REQUIRED CHANNELS PER TRIP SYSTEM	CONDITIONS REFERENCED FROM REQUIRED ACTION D.1	SURVEILLANCE REQUIREMENTS	ALLOWABLE VALUE
2. Average Power Range Monitors (continued)		1	F	SR 3.3.1.1.1 SR 3.3.1.1.2 SR 3.3.1.1.3 SR 3.3.1.1.4 SR 3.3.1.1.5 SR 3.3.1.1.6 SR 3.3.1.1.7	SR 3.3.1.1.5
c. Fixed Neutron Flux - High	1	X2X	F	SR 3.3.1.1.1 SR 3.3.1.1.2 SR 3.3.1.1.3 SR 3.3.1.1.4 SR 3.3.1.1.5 SR 3.3.1.1.6 SR 3.3.1.1.7	SR 3.3.1.1.5
d. Downscale	1	X2X	F	SR 3.3.1.1.8 SR 3.3.1.1.9 SR 3.3.1.1.15	SR 3.3.1.1.5
Inop	1,2	X2X	G	SR 3.3.1.1.8 SR 3.3.1.1.9 SR 3.3.1.1.15	SR 3.3.1.1.5
3. Reactor Vessel Steam Dome Pressure - High	1,2	X2X	G	SR 3.3.1.1.1 SR 3.3.1.1.2 SR 3.3.1.1.3 SR 3.3.1.1.4 SR 3.3.1.1.5 SR 3.3.1.1.6 SR 3.3.1.1.7	SR 3.3.1.1.5
4. Reactor Vessel Water Level - Low	1,2	X2X	G	SR 3.3.1.1.1 SR 3.3.1.1.2 SR 3.3.1.1.3 SR 3.3.1.1.4 SR 3.3.1.1.5 SR 3.3.1.1.6 SR 3.3.1.1.7	SR 3.3.1.1.5
5. Main Steam Isolation Valve - Closure	1	X2X	F	SR 3.3.1.1.8 SR 3.3.1.1.9 SR 3.3.1.1.15	SR 3.3.1.1.5
6. Drywell Pressure - High	1,2	X2X	G	SR 3.3.1.1.1 SR 3.3.1.1.2 SR 3.3.1.1.3 SR 3.3.1.1.4 SR 3.3.1.1.5 SR 3.3.1.1.6 SR 3.3.1.1.7	SR 3.3.1.1.5

(continued)

SR 3.3.1.1.18

Table 3.3.1.1-1 (page 3 of 3)
Reactor Protection System Instrumentation

(CTS)
(T 3.1.A-1)
(T 4.1.A-1)
(T 2.2.A-1)

FUNCTION	APPLICABLE MODES OR OTHER SPECIFIED CONDITIONS	REQUIRED CHANNELS PER TRIP SYSTEM	CONDITIONS REFERENCED FROM REQUIRED ACTION D.1	SURVEILLANCE REQUIREMENTS	ALLOWABLE VALUE
7. Scram Discharge Volume Water Level - High		1			
a. Resistance Temperature Detector	1,2	XX			
Thermal Switch	5(a)	XX			
b. Float Switch	1,2	XX			
Differential Pressure	5(a)	XX			
8. Turbine Stop Valve - Closure	≥ 100% RTP	XX			
9. Turbine Control Valve Fast Closure, Trip Oil Pressure - Low	≥ 100% RTP	XX			
10. Reactor Mode Switch - Shutdown Position	1,2	XX			
Manual Scram	1,2	XX			
	5(a)	XX			

3
SA 3.3.1.1.5

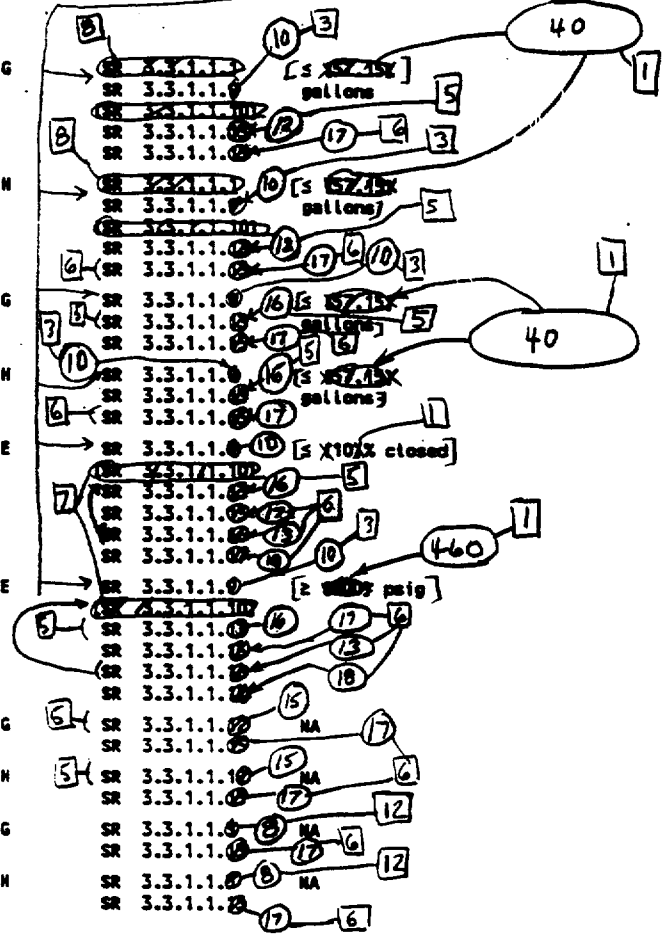

(a) With any control rod withdrawn from a core cell containing one or more fuel assemblies.

10. Turbine Condenser Vacuum - Low

1	2	F	SR 3.3.1.1.5 SR 3.3.1.1.10 SR 3.3.1.1.12 SR 3.3.1.1.17 SR 3.3.1.1.18	≥ 21 inches Hg vacuum
---	---	---	--	-----------------------

10

JUSTIFICATION FOR DEVIATIONS FROM NUREG-1433, REVISION 1
ITS: 3.3.1.1 - RPS INSTRUMENTATION

1. The brackets have been removed and the proper plant specific information/value has been provided.
2. The Completion Time of ISTS 3.3.1.1 Required Action F.1 (ITS 3.3.1.1 Required Action F.1) has been extended by 2 hours and the requirements to perform ISTS SR 3.3.1.1.4 (ITS SR 3.3.1.1.4), ISTS SR 3.3.1.1.11 (ITS SR 3.3.1.1.14), ISTS SR 3.3.1.1.13 (ITS SR 3.3.1.1.16) after entering MODE 2 has been extended by 12 hours, consistent with the current licensing basis.
3. ISTS SR 3.3.1.1.5 was intended as a CHANNEL FUNCTIONAL TEST of Manual Scram and IRM Functions (in MODE 5) as indicated in ISTS Table 3.3.1.1-1. Since the Manual Scram Function at Quad Cities 1 and 2 is different from the standard design assumed in the ISTS, this SR has been revised. Each RPS trip system at Quad Cities 1 and 2 includes three channels, 2 automatic and one manual, while the standard design assumes only two channels (which also include the Manual Functions). At Quad Cities 1 and 2, the automatic and manual trip channels are independent from each other while in the standard design the trip channels are one in the same. This SR has been revised to functionally test each RPS automatic scram contractor. This functional test was added to allow Surveillance test interval extensions of the automatic RPS Functions per NEDC-30851-P-A since the Quad Cities 1 and 2 design is different from the generic design. Since the contactors are required for the OPERABILITY of each automatic Function it has been associated with each automatic scram Function in Table 3.3.1.1-1. The Manual Scram Function (ITS Table 3.3.1.1-1 Function 12) will be tested consistent with the current requirements in proposed ITS 3.3.1.1.8 every 31 days. Subsequent SRs have been renumbered as required. In addition, the CHANNEL FUNCTIONAL TEST associated with the IRMs in MODE 5 (ISTS SR 3.3.1.1.5) has been renumbered as SR 3.3.1.1.4 since this test is also a CHANNEL FUNCTIONAL TEST performed at the same Frequency.
4. The Frequency for ISTS SR 3.3.1.1.8 (proposed ITS SR 3.3.1.1.9) has been changed from 1000 MWD/T to 2000 effective full power hours consistent with the current Quad Cities 1 and 2 Licensing Basis.
5. The Drywell Pressure—High (ITS Table 3.3.1.1-1 Function 6) and Turbine Condenser Vacuum—Low (ITS Table 3.3.1.1-1 Function 10) Functions are required to be calibrated every 92 days in accordance with the current setpoint methodology. Therefore, an SR has been added (ITS SR 3.3.1.1.13) to ensure the licensing basis is retained. Subsequent SRs have been renumbered, as required. ISTS SR 3.3.1.1.13 (the 18 month CHANNEL CALIBRATION) has been removed from the Drywell Pressure—High Function since it is redundant to the 92 day CHANNEL CALIBRATION.

JUSTIFICATION FOR DEVIATIONS FROM NUREG-1433, REVISION 1
ITS: 3.3.1.1 - RPS INSTRUMENTATION

6. ISTS SR 3.3.1.1.14 has been deleted since the APRM Flow Biased Neutron Flux—High circuit does not include the simulated heat flux time constant. However, a new SR has been added to the APRM Flow Biased Neutron Flux—High Function to perform a CHANNEL CALIBRATION of the flow converters (ITS SR 3.3.1.1.16). In addition, a Note to ISTS SR 3.3.1.1.11 (ITS SR 3.3.1.1.14) is added to clarify the applicability of the CHANNEL CALIBRATION SRs to the flow converters. Subsequent SRs have been renumbered, as required.
7. The bracketed requirement has been deleted since it does not apply to the current Quad Cities 1 and 2 licensing basis. Subsequent Functions have been renumbered, as applicable.
8. The ITS SR 3.3.1.1.1, CHANNEL CHECK, cannot be performed, since no indicators are provided, for the channels associated with the following Functions. Therefore, the CHANNEL CHECK requirement has been deleted from the associated Function Surveillance Requirements in ITS Table 3.3.1.1-1.

Function 6, Drywell Pressure — High
Function 7, Scram Discharge Volume Water Level — High

This is consistent with the current licensing basis.
9. The proper Quad Cities 1 and 2 plant specific nomenclature/value/design requirements have been provided.
10. ITS Table 3.3.1.1-1 Function 10, Turbine Condenser Vacuum—Low, has been added consistent with the current licensing basis for RPS Instrumentation. Subsequent Functions have been renumbered, as required.
11. The Frequency for ISTS SR 3.3.1.1.6 has been changed from "Prior to withdrawing SRMs from the fully inserted position" to "Prior to fully withdrawing SRMs." The current licensing basis for Quad Cities 1 and 2 only requires the SRM/IRM overlap to be verified during a reactor startup. It does not require the overlap verification prior to withdrawing the SRMs from the fully inserted position. During the reactor startup, the operating staff may start to withdraw the SRMs prior to the IRMs coming on range. This reduces the burnup of the SRMs. The SRM/IRM overlap would be verified before the SRMs are fully withdrawn. Therefore, ITS SR 3.3.1.1.6 has been modified and is consistent with current licensing basis.
12. SR 3.3.1.1.8 has been added to the Surveillance Requirements in ITS 3.3.1.1 for the Manual Scram Function. This change is consistent with the CTS.

JUSTIFICATION FOR DEVIATIONS FROM NUREG-1433, REVISION 1
ITS: 3.3.1.1 - RPS INSTRUMENTATION

13. A requirement to perform an RPS RESPONSE TIME test on the Drywell Pressure—High Function channels has been added since the Function is credited in the safety analyses.
14. Typographical error corrected.
15. An Actions Note is added to allow time to adjust the gain for the APRMs. This Note is included in CTS Table 4.1.A-1 as Note (d), and is based on both the time frame necessary to accomplish multiple channel gain adjustments and the impact on safety. Only two hours are provided if the GAF is non-conservative; but 12 hours are provided if the GAF is out of limits low since this makes the trip setpoint conservative.
16. TSTF-264 deletes the Surveillances for SRM/IRM overlap during startup and the APRM/IRM overlap during shutdown. The TSTF states that these SRs are unnecessary since they duplicate the requirements of the Channel Check. However, the Channel Check definition does not specifically require overlap checks. There are other instruments that have overlapping ranges (e.g., reactor water level instruments), and no "overlap" checks are implied by the Channel Check requirements for these instruments. Also, as stated in the TSTF Bases portion of the change, the SRM/IRM overlap check is only applicable during a startup and the APRM/IRM overlap check is only required during a shutdown. It would appear that if the Channel Check definition requires overlap checks, it would require the checks both during a startup and during a shutdown for all instruments. In addition, the TSTF also provides Bases to the Channel Check Surveillances that add requirements not in the actual Channel Check Surveillance. For example, the Channel Check is required to be performed every 12 hours in the actual Specification, but the TSTF Bases portion of the change requires the SRM/IRM overlap portion to be performed prior to withdrawing the SRMs. Therefore, this TSTF is not being adopted and the individual overlap SRs are being maintained.
17. ISTS SR 3.3.1.1.16 (ITS SR 3.3.1.1.13) requires verification that the Turbine Stop Valve - Closure and Turbine Control Valve Fast Closure, Trip Oil Pressure - Low Functions are not bypassed when THERMAL POWER is $\geq 45\%$ RTP. The Frequency of this SR has been revised to once per 92 days to reflect current plant practice and setpoint methodology.

{CTS}

3.3 INSTRUMENTATION

3.3.1.2 Source Range Monitor (SRM) Instrumentation

{3.2.G}

{3.10.B}

LCO 3.3.1.2 The SRM instrumentation in Table 3.3.1.2-1 shall be OPERABLE.

{App 3.2.G}

{App 3.10.B}

APPLICABILITY: According to Table 3.3.1.2-1.

ACTIONS

CONDITION	REQUIRED ACTION	COMPLETION TIME
A. One or more required SRMs inoperable in MODE 2 with intermediate range monitors (IRMs) on Range 2 or below.	A.1 Restore required SRMs to OPERABLE status.	4 hours
B. ¹ Three required SRMs inoperable in MODE 2 with IRMs on Range 2 or below.	B.1 Suspend control rod withdrawal.	Immediately
C. Required Action and associated Completion Time of Condition A or B not met.	C.1 Be in MODE 3.	12 hours

{3.2.G
Act 1}

{DOC L.1}

{3.2.G
Act 1}

(continued)

{CTS}

ACTIONS (continued)

CONDITION	REQUIRED ACTION	COMPLETION TIME
<i>{3.2.6}</i> <i>{Act 2}</i> D. One or more required SRMs inoperable in MODE 3 or 4.	D.1 Fully insert all insertable control rods.	1 hour
	<u>AND</u> D.2 Place reactor mode switch in the shutdown position.	1 hour
<i>{3.10. BAction}</i> E. One or more required SRMs inoperable in MODE 5.	E.1 Suspend CORE ALTERATIONS except for control rod insertion.	Immediately
	<u>AND</u> E.2 Initiate action to fully insert all insertable control rods in core cells containing one or more fuel assemblies.	Immediately

6 (CTS)

SURVEILLANCE REQUIREMENTS

NOTE

{DOC A.3}

Refer to Table 3.3.1.2-1 to determine which SRs apply for each applicable MODE or other specified conditions.

2

SURVEILLANCE		FREQUENCY
<p>{4.2.G.2.a}</p> <p>{4.10.B.1.a}</p> <p>SR 3.3.1.2.1</p>	Perform CHANNEL CHECK.	12 hours
<p>{4.10.B.1.c}</p> <p>{DOC M.3}</p> <p>{3.10.B App 2}</p> <p>{DOC M.2}</p> <p>SR 3.3.1.2.2</p>	<p>NOTES</p> <p>1. Only required to be met during CORE ALTERATIONS.</p> <p>2. One SRM may be used to satisfy more than one of the following.</p> <hr/> <p>Verify an OPERABLE SRM detector is located in:</p> <p>a. The fueled region;</p> <p>b. The core quadrant where CORE ALTERATIONS are being performed, when the associated SRM is included in the fueled region; and</p> <p>c. A core quadrant adjacent to where CORE ALTERATIONS are being performed, when the associated SRM is included in the fueled region.</p>	12 hours
<p>{4.2.G.2.b}</p> <p>SR 3.3.1.2.3</p>	Perform CHANNEL CHECK.	24 hours

(continued)

2 (CTS)

SURVEILLANCE REQUIREMENTS (continued)

SURVEILLANCE	FREQUENCY
<p>SR 3.3.1.2.4</p> <p>NOTE</p> <p>Not required to be met with less than or equal to four fuel assemblies adjacent to the SRM and no other fuel assemblies in the associated core quadrant.</p> <p>Verify count rate is:</p> <p>a. $\geq 3.0\%$ cps with a signal to noise ratio $\geq 12:1$; or</p> <p>b. $\geq 0.7\%$ cps with a signal to noise ratio $\geq 20:1$.</p>	<p>12 hours during CORE ALTERATIONS</p> <p>AND</p> <p>24 hours</p>
<p>SR 3.3.1.2.5</p> <p>Perform CHANNEL FUNCTIONAL TEST and determination of signal to noise ratio.</p>	<p>7 days</p>
<p>SR 3.3.1.2.6</p> <p>NOTE</p> <p>Not required to be performed until 12 hours after IRMs on Range 2 or below.</p> <p>Perform CHANNEL FUNCTIONAL TEST and determination of signal to noise ratio.</p>	<p>31 days</p>
<p>SR 3.3.1.2.7</p> <p>NOTES</p> <p>1. Neutron detectors are excluded.</p> <p>2. Not required to be performed until 12 hours after IRMs on Range 2 or below.</p> <p>Perform CHANNEL CALIBRATION.</p>	<p>24 months</p>

{4.2.G.1}
{Appl 3.10.B}
{4.10.B.3}
{3.10.B Appl 2}

4
Insert SR 3.3.1.2.5

{4.10.B.2}
{DOC M.5}

{4.2.G.3.b}
{+ footnote b}

{4.2.G.4}
{+ footnote b+c}
{DOC M.4}

<CTS>

4

Insert SR 3.3.1.2.5

-----NOTE-----

The determination of signal to noise ratio is not required to be met with less than or equal to four fuel assemblies adjacent to the SRM and no other fuel assemblies in the associated core quadrant.

<DOC M.5>

<DOC L.7>

(CTS)

SRM Instrumentation
3.3.1.2

(3.2.G) (Appl 3.2.G)

(3.10.B) (Appl 3.10.B)

Table 3.3.1.2-1 (page 1 of 1)
Source Range Monitor Instrumentation

FUNCTION	APPLICABLE MODES OR OTHER SPECIFIED CONDITIONS	REQUIRED CHANNELS	SURVEILLANCE REQUIREMENTS
1. Source Range Monitor	2(a)	SRM 	SR 3.3.1.2.1 SR 3.3.1.2.4 SR 3.3.1.2.6 SR 3.3.1.2.7
	3,4	2	SR 3.3.1.2.3 SR 3.3.1.2.4 SR 3.3.1.2.6 SR 3.3.1.2.7
	5	2(b)(c)	SR 3.3.1.2.1 SR 3.3.1.2.2 SR 3.3.1.2.4 SR 3.3.1.2.5 SR 3.3.1.2.7

(DOC L7)

- (a) With IRMs on Range 2 or below.
- (b) Only one SRM channel is required to be OPERABLE during spiral offload or reload when the fueled region includes only that SRM detector.
- (c) Special movable detectors may be used in place of SRMs if connected to normal SRM circuits.

JUSTIFICATION FOR DEVIATIONS FROM NUREG-1433, REVISION 1
ITS: 3.3.1.2 - SRM INSTRUMENTATION

1. The brackets have been removed and the proper plant specific information/value has been provided.
2. Editorial change made to be consistent with other similar requirements in the ITS or for clarity.
3. Changes have been made to be consistent with the current Quad Cities 1 and 2 licensing basis.
4. New Note has been added to ISTS SR 3.3.1.2.5 to state that the determination of the signal to noise ratio is not required to be met with less than or equal to four fuel assemblies adjacent to the SRM and no other fuel in the associated core quadrant. When starting to load fuel from the defueled condition, SR 3.3.1.2.5 must be current prior to the start of fuel load. However, with no fuel in the core, a signal to noise ratio cannot be determined. Therefore, this Note has been added similar to the Note in the count rate Surveillance (ISTS SR 3.3.1.2.4), which is for the same reason as this proposed Note.

{CTS}

Control Rod Block Instrumentation
3.3.2.1

3.3 INSTRUMENTATION

3.3.2.1 Control Rod Block Instrumentation

{3.2.E}
{3.2.L}

LCO 3.3.2.1 The control rod block instrumentation for each Function in Table 3.3.2.1-1 shall be OPERABLE.

{App 3.2.E}
{App 3.2.L}
{App 3.3.M}

APPLICABILITY: According to Table 3.3.2.1-1.

ACTIONS

CONDITION	REQUIRED ACTION	COMPLETION TIME
<p>{3.2.E Act 1+2}</p> <p>{T.3.2.E-1 ACTION 5b}</p> <p>{3.3.M Act 1.b}</p> <p>A. One rod block monitor (RBM) channel inoperable.</p>	A.1 Restore RBM channel to OPERABLE status.	24 hours
<p>{3.2.E Act 1+2}</p> <p>{T.3.2.E-1 ACTION 5b}</p> <p>{3.3.M Act 2}</p> <p>B. Required Action and associated Completion Time of Condition A not met.</p> <p><u>OR</u></p> <p>Two RBM channels inoperable.</p>	B.1 Place one RBM channel in trip.	1 hour
<p>{3.3.L Action}</p> <p>{3.3.M Act 2}</p> <p>C. Rod worth minimizer (RWM) inoperable during reactor startup.</p>	C.1 Suspend control rod movement except by scram.	Immediately

(continued)

<CTS>

Control Rod Block Instrumentation
3.3.2.1

ACTIONS

CONDITION	REQUIRED ACTION	COMPLETION TIME
<p>C. (continued) {3.3.L Action} {DOC M.4}</p>	<p>C.2.1.1 Verify ≥ 12 rods withdrawn. OR C.2.1.2 Verify by administrative methods that startup with RWM inoperable has not been performed in the last calendar year. AND C.2.2 Verify movement of control rods is in compliance with banked position withdrawal sequence (BPWS) by a second licensed operator or other qualified member of the technical staff.</p>	<p>Immediately Immediately During control rod movement</p>
<p>D. RWM inoperable during reactor shutdown. {3.3.L Action}</p>	<p>D.1 Verify movement of control rods is in accordance with BPWS by a second licensed operator or other qualified member of the technical staff.</p>	<p>During control rod movement</p>

banked position withdrawal sequence (BPWS)

the analyzed rod position sequence

accordance with BPWS

analyzed rod position sequence

Compliance

(continued)

2

1

<CTS>

Control Rod Block Instrumentation
3.3.2.1

ACTIONS (continued)

CONDITION	REQUIRED ACTION	COMPLETION TIME
E. One or more Reactor Mode Switch—Shutdown Position channels inoperable. <DOC.M.1>	E.1 Suspend control rod withdrawal.	Immediately
	AND E.2 Initiate action to fully insert all insertable control rods in core cells containing one or more fuel assemblies.	Immediately

SURVEILLANCE REQUIREMENTS

NOTES

<4.2.E>

1. Refer to Table 3.3.2.1-1 to determine which SRs apply for each Control Rod Block Function.
2. When an RBM channel is placed in an inoperable status solely for performance of required Surveillances, entry into associated Conditions and Required Actions may be delayed for up to 6 hours provided the associated Function maintains control rod block capability.

<T 3.2.E1 footnote i>

SURVEILLANCE	FREQUENCY
<T 4.2.E-1> <4.3.M.1> SR 3.3.2.1.1 Perform CHANNEL FUNCTIONAL TEST.	92% days 3

(continued)

<CTS>

SURVEILLANCE REQUIREMENTS (continued)

SURVEILLANCE	FREQUENCY
<p><i><4.3.L.2></i> <i><DOC L.2></i> <i><DOC M.3></i></p> <p>SR 3.3.2.1.2</p> <p style="text-align: center;">-----NOTE-----</p> <p>Not required to be performed until 1 hour after any control rod is withdrawn at $\leq 10\%$ RTP in MODE 2.</p> <hr/> <p>Perform CHANNEL FUNCTIONAL TEST.</p>	<p style="text-align: right;">$\leq 92\%$ days</p> <p style="text-align: right;">} [3]</p>
<p><i>(T 4.2, E-1) <4.3.L.3> <DOC L.2></i></p> <p>SR 3.3.2.1.3</p> <p style="text-align: center;">-----NOTE-----</p> <p>Not required to be performed until 1 hour after THERMAL POWER is $\leq 10\%$ RTP in MODE 1.</p> <hr/> <p>Perform CHANNEL FUNCTIONAL TEST.</p>	<p style="text-align: right;">$\leq 92\%$ days</p> <p style="text-align: right;">} [3]</p>
<p><i><DOC M.5></i> SR 3.3.2.1.4</p> <p><i>(T 4.2, E-1) footnote a</i></p> <p style="text-align: center;">-----NOTE-----</p> <p>* Neutron detectors are excluded.</p> <hr/> <p>Verify the RBM</p> <div style="border: 1px solid black; padding: 5px;"> <p>a. Low Power Range—Upscale Function is not bypassed when THERMAL POWER is $\geq 29\%$ and $\leq 64\%$ RTP.</p> <p>b. Intermediate Power Range—Upscale Function is not bypassed when THERMAL POWER is $> 64\%$ and $\leq 84\%$ RTP.</p> <p>c. High Power Range—Upscale Function is not bypassed when THERMAL POWER is $> 84\%$ RTP.</p> </div>	<p style="text-align: right;">≤ 24 months</p> <p style="text-align: right;">} [3]</p> <p style="text-align: right;">} [4]</p>
<p><i><DOC M.5></i> SR 3.3.2.1.5</p> <p>Verify the RBM is not bypassed when THERMAL POWER is $\leq 10\%$ RTP.</p>	<p style="text-align: right;">≤ 24 months</p> <p style="text-align: right;">} [3]</p>

[5]

Insert SR 3.3.2.1.4 from page 33-19

[4]

is not bypassed when THERMAL POWER is $\geq 30\%$ RTP and when a peripheral control rod is not selected

-----NOTE-----

* Neutron detectors are excluded.

Verify the RBM

a. Low Power Range—Upscale Function is not bypassed when THERMAL POWER is $\geq 29\%$ and $\leq 64\%$ RTP.

b. Intermediate Power Range—Upscale Function is not bypassed when THERMAL POWER is $> 64\%$ and $\leq 84\%$ RTP.

c. High Power Range—Upscale Function is not bypassed when THERMAL POWER is $> 84\%$ RTP.

(continued)

<CTS>

Control Rod Block Instrumentation
3.3.2.1

SURVEILLANCE REQUIREMENTS (continued)

SURVEILLANCE

FREQUENCY

5
<DOC M.1>
move to page 33-18 as indicated

SR 3.3.2.1.6

7
5

NOTE

Not required to be performed until 1 hour after reactor mode switch is in the shutdown position.

Perform CHANNEL FUNCTIONAL TEST.

24
18 months 3

<T 4.2. E-1>
<T 4.2. E-1 footnote a>
<4.3.M.1>

SR 3.3.2.1.7

4
5

NOTE

Neutron detectors are excluded.

Perform CHANNEL CALIBRATION.

92 days 5
~~18~~ months

<4.3.L.1>

SR 3.3.2.1.8

Verify control rod sequences input to the RWM are in conformance with BPPS.

analyzed rod position sequence

Prior to declaring RWM OPERABLE following loading of sequence into RWM

1

<DOC M.6>

SR 3.3.2.1.9

Verify the bypassing and position of control rods required to be bypassed in RWM by a second licensed operator or other qualified member of the technical staff

Prior to and during the movement of control rods bypassed in RWM

6

<CTS>

Control Rod Block Instrumentation
3.3.2.1

<T 3.2.E-1>
<T 4.2.E-1>
<3.3.L>
<3.3.M>

Table 3.3.2.1-1 (page 1 of 1)
Control Rod Block Instrumentation

FUNCTION	APPLICABLE MODES OR OTHER SPECIFIED CONDITIONS	REQUIRED CHANNELS	SURVEILLANCE REQUIREMENTS	ALLOWABLE VALUE
1. Rod Block Monitor				
a. Low Power Range - Upscale	(a)	X2X	SR 3.3.2.1.1 SR 3.3.2.1.6 SR 3.3.2.1.7	≤ [115.5/125] divisions of full scale <i>As specified in the COLR</i>
b. Intermediate Power Range - Upscale	(b)	[2]	SR 3.3.2.1.1 SR 3.3.2.1.4 SR 3.3.2.1.7	≤ [109.7/125] divisions of full scale
c. High Power Range - Upscale	(c), (d)	[2]	SR 3.3.2.1.1 SR 3.3.2.1.4 SR 3.3.2.1.7	≤ [105.9/125] divisions of full scale
d. Inop	(a)	X2X	SR 3.3.2.1.1	NA
e. Downscale	(a)	X2X	SR 3.3.2.1.1 SR 3.3.2.1.6 SR 3.3.2.1.7	≥ [115.5/125] divisions of full scale
f. Bypass Time Delay	(d), (e)	[2]	SR 3.3.2.1.1 SR 3.3.2.1.7	≤ [2.0] seconds
2. Rod Worth Minimizer		X1X	SR 3.3.2.1.2 SR 3.3.2.1.3 SR 3.3.2.1.8 SR 3.3.2.1.8	NA
3. Reactor Mode Switch - Shutdown Position		X2X	SR 3.3.2.1.6	NA
(a) THERMAL POWER ≥ [29%] and ≤ [64%] RTP and NCPR < 1.70.				RTP and no peripheral control rod selected
(b) THERMAL POWER > [64%] and ≤ [84%] RTP and NCPR < 1.70.				
(c) THERMAL POWER > [84%] and < 90% RTP and NCPR < 1.70.				
(d) THERMAL POWER ≥ 90% RTP and NCPR < 1.40.				
(e) THERMAL POWER ≥ [64%] and < 90% RTP and NCPR < 1.70.				
(b) With THERMAL POWER ≤ 110% RTP.				
(c) Reactor mode switch in the shutdown position.				

JUSTIFICATION FOR DEVIATIONS FROM NUREG-1433, REVISION 1
ITS: 3.3.2.1 - CONTROL ROD BLOCK INSTRUMENTATION

1. The proper Quad Cities 1 and 2 plant specific nomenclature/value/design requirements have been provided.
2. Editorial change made to be consistent with Required Action C.2.2.
3. The brackets have been removed and the proper plant specific information/value has been provided.
4. ISTS SR 3.3.2.1.4 and ISTS Table 3.3.2.1-1, Note (a) have been modified and ISTS Table 3.3.2.1-1, Functions 1.b, 1.c, and 1.f, including Notes (b), (c), (d), and (e) have been deleted to be consistent with the Quad Cities 1 and 2 RBM design. The RBM design in the ISTS is based on a "Post-ARTS" RBM design. Quad Cities 1 and 2 has not installed the "ARTS" RBM modification. In addition, the requirements have been renumbered, where applicable, to reflect the deletions.
5. ISTS SR 3.3.2.1.7 has been renumbered as SR 3.3.2.1.4 and the bracketed Frequency has been changed from 18 months to 92 days consistent with the current licensing basis. The Surveillances have been reordered and renumbered as required.
6. A new Surveillance (ITS 3.3.2.1.9) has been added to the ITS 3.3.2.1 consistent with the current and proposed requirements in the LaSalle Unit 1 and 2 Technical Specifications. This change was added for consistency between ComEd Boiling Water Reactor Technical Specifications.

{CTS}

System 1
Feedwater and Main Turbine High Water Level Trip Instrumentation
3.3.2.2

3.3 INSTRUMENTATION System 1

3.3.2.2 Feedwater and Main Turbine High Water Level Trip Instrumentation

LCO 3.3.2.2 ~~Channels~~ channels of feedwater and main turbine high water level trip instrumentation shall be OPERABLE.

{3.2J}
{T 3.2J-1}

{Appl 3.2J}

APPLICABILITY: THERMAL POWER \geq ~~25%~~ RTP.

ACTIONS

NOTE
Separate Condition entry is allowed for each channel.

CONDITION	REQUIRED ACTION	COMPLETION TIME
A. One feedwater and main turbine high water level trip channel inoperable.	A.1 Place channel in trip.	7 days
B. One or more feedwater and main turbine high water level trip channels inoperable.	B.1 Restore feedwater and main turbine high water level trip capability.	2 hours
Required Action and associated Action Completion Time not met.	Reduce THERMAL POWER to $<$ 25% RTP.	4 hours

{3.2J Act}
{T 3.2J-1 ACTION 90a and b}
{3.2J Act}
{T 3.2J-1 ACTION 90b}

NOTE
B.1 Only applicable if inoperable channel is the result of an inoperable feedwater pump breaker
Remove affected feedwater pump (s) from service 4 hours
OR

System II

Feedwater and Main Turbine High Water Level Trip Instrumentation 3.3.2.2

(CTS)

SURVEILLANCE REQUIREMENTS

(T 3.2.5-1)
footnote b

NOTE
 When a channel is placed in an inoperable status solely for performance of required Surveillances, entry into associated Conditions and Required Actions may be delayed for up to 5 hours provided feedwater and main turbine high water level trip capability is maintained.

SURVEILLANCE	FREQUENCY
SR 3.3.2.2.1 Perform CHANNEL CHECK.	24 hours
SR 3.3.2.2.2 Perform CHANNEL FUNCTIONAL TEST.	92 days
SR 3.3.2.2.3 Perform CHANNEL CALIBRATION. The Allowable Value shall be \leq [68.0] inches.	18 months
SR 3.3.2.2.4 Perform LOGIC SYSTEM FUNCTIONAL TEST including valve actuation.	18 months

(4.2.J.1)
(T 4.2.J-1)
(4.2.J.1)
(T 4.2.J-1)

(4.2.J.1)
(T 4.2.J-1)

(4.2.J.2)

breaker and

5

JUSTIFICATION FOR DEVIATIONS FROM NUREG-1433, REVISION 1
ITS: 3.3.2.2 - FEEDWATER SYSTEM AND MAIN TURBINE HIGH
WATER LEVEL TRIP INSTRUMENTATION

1. The proper Quad Cities 1 and 2 plant specific nomenclature/value/design requirements have been provided.
2. The brackets have been removed and the proper plant specific information/value has been provided.
3. The Feedwater System and Main Turbine High Water Level Trip Instrumentation channel logic design is a two-out-of-two for trip actuation. Therefore, with one channel inoperable, the trip logic does not maintain trip capability. As a result, the ISTS 3.3.2.2 allowance for "Separate Condition entry" and ISTS 3.3.2.2 ACTION A have been deleted since these allowances are based on the ability of the instrumentation to perform its safety function upon an actuation of a high water level signal with one channel inoperable. The ISTS 3.3.2.2 Surveillance Requirement Note has been revised consistent with CTS allowances since trip capability is not maintained when any channel is inoperable.
4. ISTS 3.3.2.2 Required Action C.1 (ITS Required Action B.1) requires a reduction in Thermal Power to $\leq 25\%$ RTP if the Feedwater System and Main Turbine High Water Level Trip Instrumentation is not restored to Operable status. The instrumentation indirectly supports maintaining MCPR above limits during a feedwater controller failure, maximum demand event. This is accomplished by tripping the main turbine, with the main turbine trip resulting in a subsequent reactor scram. When the instrumentation is inoperable solely due to an inoperable feedwater pump breaker, the unit can continue to operate with the feedwater pump removed from service (Quad Cities 1 and 2 have three 50% capacity feedwater pumps). Therefore, an additional Required Action is proposed, ITS 3.3.2.2, Required Action B.1, to allow removal of the associated feedwater pump(s) from service in lieu of reducing Thermal Power. This Required Action will only be used if the instrumentation is inoperable solely due to an inoperable feedwater pump breaker, as stated in the Note to ITS 3.3.2.2 Required Action B.1. Since this Required Action accomplishes the functional purpose of the Feedwater System and Main Turbine High Water Level Trip Instrumentation, enables continued operation in a previously approved condition, and still supports maintaining MCPR above limits (since the reactor scram is the result of a turbine trip signal, which is not impacted by this change), this change does not have a significant effect on safe operation. In addition, ISTS 3.3.2.2 Required Action B.1 has been renumbered due to this addition.
5. Editorial change made to be consistent with other similar requirements in the ITS or for clarity.

ε<CTS>

3.3 INSTRUMENTATION

3.3.3.1 Post Accident Monitoring (PAM) Instrumentation

{3.2.F} LCO 3.3.3.1 The PAM instrumentation for each Function in Table 3.3.3.1-1 shall be OPERABLE.

{Appl 3.2.F} APPLICABILITY: MODES 1 and 2.

ACTIONS

- {DOC L.1} NOTES
1. LCO 3.0.4 is not applicable.
 2. Separate Condition entry is allowed for each Function.

CONDITION	REQUIRED ACTION	COMPLETION TIME
{3.2.F Act} A. One or more Functions with one required channel inoperable. {T 3.2.F-1 ACTION 60a} (DOC L.5) {T 3.2.F-1 ACTION 62a}	A.1 Restore required channel to OPERABLE status.	30 days
{3.2.F Act} B. Required Action and associated Completion Time of Condition A not met. {T 3.2.F-1 ACTION 61b} (DOC L.3)	B.1 Initiate action in accordance with Specification 5.6.1. ⁶	Immediately
{3.2.F Act} C. NOTE Not applicable to [hydrogen monitor] channels. {T 3.2.F-1 ACTION 60b} One or more Functions with two required channels inoperable. {T 3.2.F-1 ACTION 61a} {T 3.2.F-1 ACTION 62b}	C.1 Restore one required channel to OPERABLE status.	7 days

2

1

(continued)

<CTS>

ACTIONS (continued)

CONDITION	REQUIRED ACTION	COMPLETION TIME
D. Two [required hydrogen monitor] channels inoperable.	D.1 Restore one [required hydrogen monitor] channel to OPERABLE status.	72 hours
(3.2.F Act) (T 3.2.F-1 ACTION 60b) (F 3.2.F-1 ACTION 62b) D. Required Action and associated Completion Time of Condition C or D not met.	E.1 Enter the Condition referenced in Table 3.3.3.1-1 for the channel.	Immediately
(3.2.F Act) (T 3.2.F-1 ACTION 60b) (F 3.2.F-1 ACTION 62b) E. As required by Required Action D.1 and referenced in Table 3.3.3.1-1.	F.1 Be in MODE 3.	12 hours
(3.2.F Act) (T 3.2.F-1 ACTION 61b) F. As required by Required Action D.1 and referenced in Table 3.3.3.1-1.	G.1 Initiate action in accordance with Specification 5.6.1.	Immediately

2

3

1

(CTS)

PAM Instrumentation
3.3.3.1

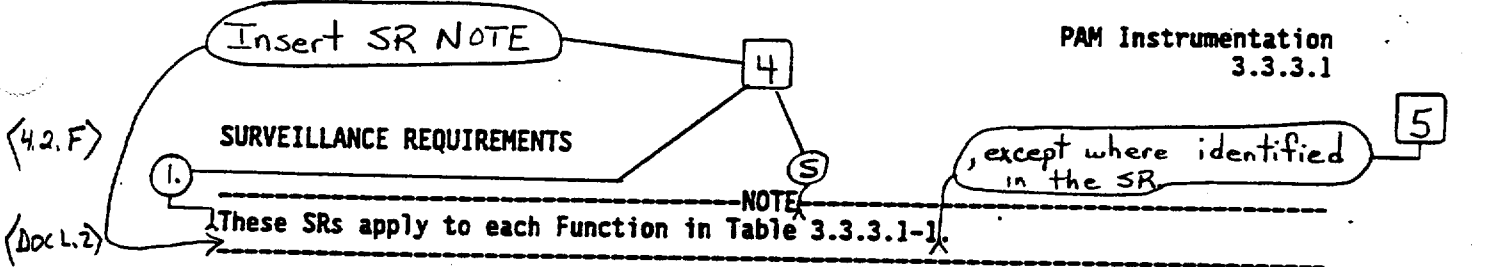

(T 4.2.F-1)

SURVEILLANCE		FREQUENCY
SR 3.3.3.1.1	Perform CHANNEL CHECK.	31 days
SR 3.3.3.1.2	Perform CHANNEL CALIBRATION for Functions other than Functions 7 and 8.	18 months

(T 4.2.F-1)

(T 4.2.F-1)

SR 3.3.3.1.2	Perform CHANNEL CALIBRATION for Functions 7 and 8.	92 days
--------------	---	---------

<CTS>

ITS 3.3.3.1

4

INSERT SR NOTE

<DOC
L.2>

2. When a channel is placed in an inoperable status solely for performance of required Surveillances, entry into associated Conditions and Required Actions may be delayed for up to 6 hours provided the other required channel in the associated Function is OPERABLE.

<CTS>
 <T 3.2.F-1>
 <T 4.2.F-1>
 <DOC M.1>

Table 3.3.3.1-1 (page 1 of 1)
Post Accident Monitoring Instrumentation

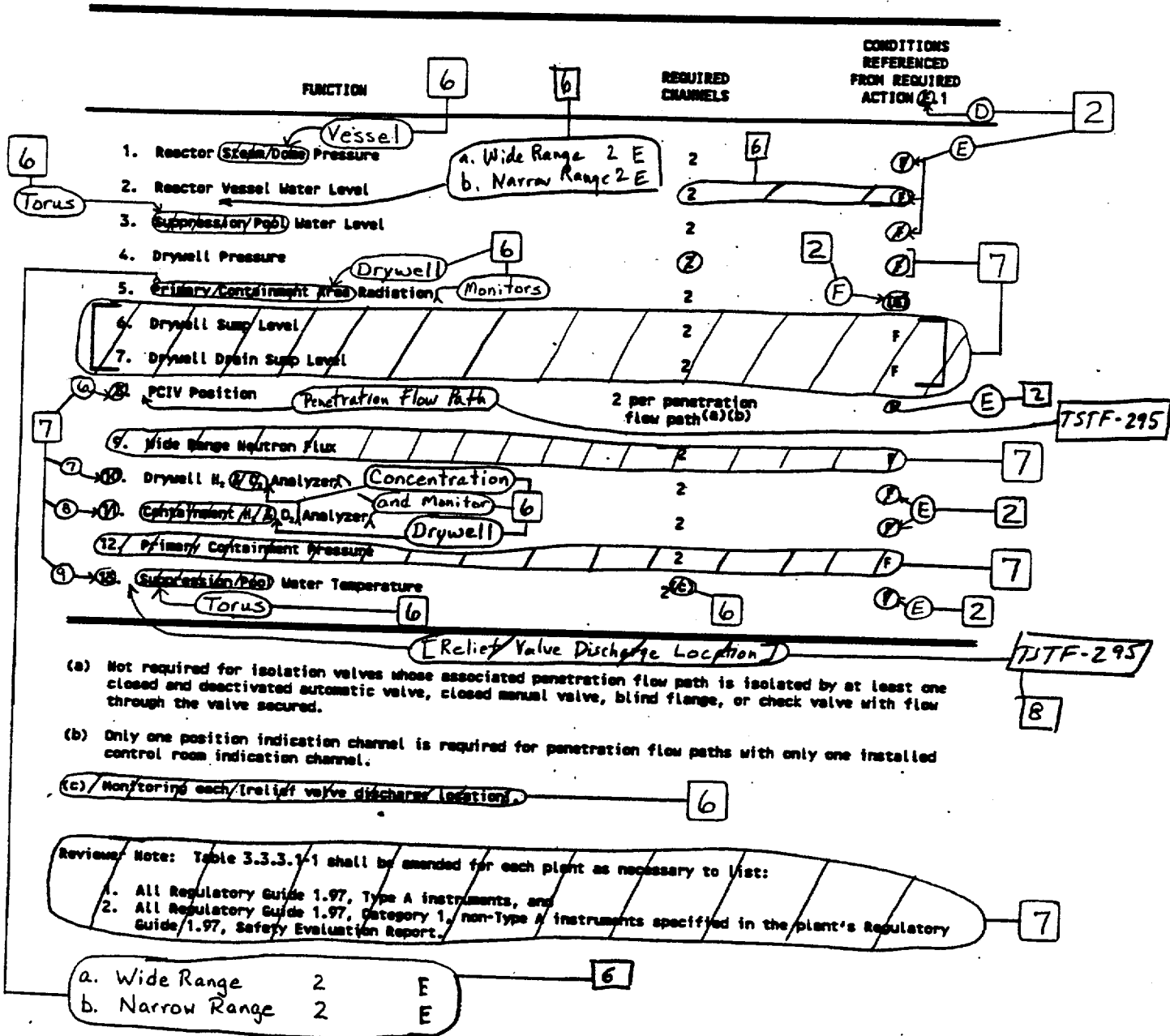

JUSTIFICATION FOR DEVIATIONS FROM NUREG-1433, REVISION 1
ITS: 3.3.3.1 - POST ACCIDENT MONITORING INSTRUMENTATION

1. The proper Specification number has been provided.
2. ISTS 3.3.3.1 ACTION D and the Note in ISTS 3.3.3.1 Condition C have been deleted. These requirements specify a 72 hour Completion Time to restore one hydrogen monitor to OPERABLE status when two hydrogen monitors are inoperable. This change will allow a 7 day Completion Time to restore one hydrogen monitor when both are inoperable, as shown in ITS 3.3.3.1 ACTION C. There is no difference, with respect to their importance during an accident, between the H₂ and O₂ monitors and other PAM instrumentation. In addition, the requirements have been renumbered, where applicable, to reflect this deletion.
3. The brackets have been removed and the proper plant specific information/value has been provided.
4. A Note has been added to the Surveillance Requirements (Note 2 for ITS 3.3.3.1) to allow a channel to be inoperable for up to 6 hours solely for performance of required Surveillances provided the other channel(s) in the associated Function are OPERABLE. The 6 hour testing allowance has been granted by the NRC in Technical Specification amendments for Georgia Power Company's Hatch Unit 1 (amendment 185) and Unit 2 (amendment 125) and Washington Public Power Supply System's WNP-2 (amendment 149, the ITS amendment). The NRC has also granted this allowance in other topical reports for the RPS, ECCS, and isolation instrumentation. In addition, the current Note to the Surveillance Requirements for ITS 3.3.3.1 has been numbered "1" to reflect this addition.
5. An additional Channel Calibration surveillance has been added consistent with the current licensing basis for the H₂ analyzer and O₂ analyzer. The remaining Surveillance has been modified and renumbered due to this addition.
6. The proper Quad Cities 1 and 2 plant specific nomenclature/value/design requirements have been provided.
7. This Reviewer's Note has been deleted and the Table revised to include the appropriate instruments, consistent with the Note. The Note is not meant to be retained in the final version of the plant specific submittal. In addition, the Functions have been renumbered, where applicable, to reflect the additions and deletions.
8. The bracketed TSTF-295 revisions associated with Suppression Pool Water Temperature (BWR NUREG-1433, ISTS Table 3.3.3.1-1, Function 13) are not incorporated in proposed Quad Cities 1 and 2 ITS Table 3.3.3.1-1 (Function 9). This difference is consistent with current licensing requirements for the Torus Water Temperature. All temperature sensors associated with a channel (irrespective of sensor location) are required to be OPERABLE for the channel to be OPERABLE.

3.3 INSTRUMENTATION

3.3.3.2 Remote Shutdown System

LCD 3.3.3.2 The Remote Shutdown System Functions in Table 3.3.3/2-1 shall be OPERABLE.

APPLICABILITY: MODES 1 and 2.

ACTIONS

NOTES

1. LCD 3.0.4 is not applicable.
2. Separate Condition entry is allowed for each Function.

CONDITION	REQUIRED ACTION	COMPLETION TIME
A. One or more required Functions inoperable.	A.1 Restore required Function to OPERABLE status.	30 days
B. Required Action and associated Completion Time not met.	B.1 Be in MODE 3.	12 hours

SURVEILLANCE REQUIREMENTS

SURVEILLANCE	FREQUENCY
SR 3.3.3.2.1 Perform CHANNEL CHECK for each required instrumentation channel that is normally energized.	31 days

(continued)

SURVEILLANCE REQUIREMENTS (continued)

SURVEILLANCE	FREQUENCY
SR 3.3.3.2.2 Verify each required control circuit and transfer switch is capable of performing the intended function.	[18] months
SR 3.3.3.2.3 Perform CHANNEL CALIBRATION for each required instrumentation channel.	[18] months

Table 3.3.3.2-1 (page 1 of 1)
Remote Shutdown System Instrumentation

FUNCTION (INSTRUMENT OR CONTROL PARAMETER)	REQUIRED NUMBER OF DIVISIONS
1. Reactor Pressure Vessel Pressure	
a. Reactor Pressure	(1)
2. Decay Heat Removal	
a. RCIC Flow	(1)
b. RCIC Controls	(1)
c. RNR Flow	(1)
d. RNR Controls	(1)
3. Reactor Pressure Vessel Inventory Control	
a. RCIC Flow	(1)
b. RCIC Controls	(1)
c. RNR Flow	(1)
d. RNR Controls	(1)

Reviewer Note: This Table is for illustration purposes only. It does not attempt to encompass every function used at every plant, but does contain the types of functions commonly found.

JUSTIFICATION FOR DEVIATIONS FROM NUREG-1433, REVISION 1
ISTS: 3.3.3.2 -REMOTE SHUTDOWN SYSTEM

1. ISTS 3.3.3.2, Remote Shutdown System, has been deleted since it is not required by the Quad Cities 1 and 2 current Technical Specifications. The Remote Shutdown System equipment is not required in the mitigation of any design basis accident or transient analysis. Requirements to ensure the plant can be placed and maintained in a safe shutdown condition from a location outside the control room are controlled by plant procedures.

3.3 INSTRUMENTATION

3.3.4.1 End of Cycle Recirculation Pump Trip (EOC-RPT) Instrumentation

LCO 3.3.4.1 a. Two channels per trip system for each EOC-RPT instrumentation Function listed below shall be OPERABLE:

1. Turbine Stop Valve (TSV)—Closure; and
2. Turbine Control Valve (TCV) Fast Closure, Trip Oil Pressure—Low.

OR

b. LCO 3.2.2, "MINIMUM CRITICAL POWER RATIO (MCP), " limits for inoperable EOC-RPT as specified in the COLR are made applicable.

APPLICABILITY: THERMAL POWER > [30]% RTP.

ACTIONS

NOTE

Separate Condition entry is allowed for each channel.

CONDITION	REQUIRED ACTION	COMPLETION TIME
A. One or more channels inoperable.	A.1 Restore channel to OPERABLE status.	72 hours
	OR A.2 NOTE Not applicable if inoperable channel is the result of an inoperable breaker.	
	Place channel in trip.	72 hours

(continued)

ACTIONS (continued)

CONDITION	REQUIRED ACTION	COMPLETION TIME
B. One or more Functions with EOC-RPT trip capability not maintained. [AND MCPR limit for inoperable EOC-RPT not made applicable.]	B.1 Restore EOC-RPT trip capability.	2 hours
	OR B.2 Apply the MCPR limit for inoperable EOC-RPT as specified in the COLR.	2 hours
C. Required Action and associated Completion Time not met.	C.1 Remove the associated recirculation pump from service.	4 hours
	OR C.2 Reduce THERMAL POWER to < [30]% RTP.	4 hours

SURVEILLANCE REQUIREMENTS

NOTE
When a channel is placed in an inoperable status solely for performance of required Surveillances, entry into associated Conditions and Required Actions may be delayed for up to 6 hours provided the associated Function maintains EOC-RPT trip capability.

SURVEILLANCE	FREQUENCY
SR 3.3.4.1.1 Perform CHANNEL FUNCTIONAL TEST.	[92] days

(continued)

SURVEILLANCE REQUIREMENTS (continued)

SURVEILLANCE	FREQUENCY
<input type="checkbox"/> SR 3.3.4.1.2 Calibrate the trip units.	[92] days <input type="checkbox"/>
SR 3.3.4.1.3 Perform CHANNEL CALIBRATION. The Allowable Values shall be: TSV—Closure: \geq [10]% closed; and TCV Fast Closure, Trip Oil Pressure—Low: \geq [600] psig.	[18] months
SR 3.3.4.1.4 Perform LOGIC SYSTEM FUNCTIONAL TEST including breaker actuation.	[18] months
SR 3.3.4.1.5 Verify TSV—Closure and TCV Fast Closure, Trip Oil Pressure—Low Functions are not bypassed when THERMAL POWER is \geq [30]% RTP.	[18] months
SR 3.3.4.1.6 -----NOTE----- Breaker [interruption] time may be assumed from the most recent performance of SR 3.3.4.1.7. Verify the EOC-RPT SYSTEM RESPONSE TIME is within limits.	[18] months on a STAGGERED TEST BASIS
SR 3.3.4.1.7 Determine RPT breaker [interruption] time.	60 months

JUSTIFICATION FOR DEVIATIONS FROM NUREG-1433, REVISION 1
ISTS: 3.3.4.1 - END OF CYCLE RECIRCULATION PUMP TRIP (EOC-RPT)
INSTRUMENTATION

1. This Specification has been deleted since the Quad Cities 1 and 2 design does not include the End of Cycle Recirculation Pump Trip Instrumentation. This is consistent with the current licensing basis.

<CTS>

3.3 INSTRUMENTATION

3.3.4.0 Anticipated Transient Without Scram Recirculation Pump Trip (ATWS-RPT) Instrumentation

<3.2.C>
<T 3.2.C-1>

LCO 3.3.4.0

Two channels per trip system for each ATWS-RPT instrumentation function listed below shall be OPERABLE:

- a. Reactor Vessel Water Level—Low Low, Level 2; and
- b. Reactor Steam Dome Pressure—High.

Vessel - 2

2

<Appl 3.2.C> APPLICABILITY: MODE 1.

ACTIONS

<DOC A.2> ~~NOTE~~
Separate Condition entry is allowed for each channel.

CONDITION	REQUIRED ACTION	COMPLETION TIME
<3.2.C Act 1> A. One or more channels inoperable. <3.2.C Act 2> <3.2.C Act 3> <3.2.C Act 4>	A.1 Restore channel to OPERABLE status.	14 days
	OR A.2 NOTE Not applicable if inoperable channel is the result of an inoperable breaker. Place channel in trip.	14 days

(continued)

< CTS >

ACTIONS (continued)

CONDITION	REQUIRED ACTION	COMPLETION TIME
{3.2.C Act 1} {3.2.C Act 5} B. One Function with ATWS-RPT trip capability not maintained.	B.1 Restore ATWS-RPT trip capability.	72 hours
{3.2.C Act 1} {3.2.C Act 6} C. Both Functions with ATWS-RPT trip capability not maintained.	C.1 Restore ATWS-RPT trip capability for one Function.	1 hour
{3.2.C Act 2} {3.2.C Act 4} {3.2.C Act 5} {3.2.C Act 6} D. Required Action and associated Completion Time not met.	D.1 Remove the associated recirculation pump from service.	6 hours
	OR D.2 Be in MODE 2.	6 hours

SURVEILLANCE REQUIREMENTS

{T 3.2.C-1}
footnote a

-----NOTE-----

When a channel is placed in an inoperable status solely for performance of required Surveillances, entry into associated Conditions and Required Actions may be delayed for up to 6-hours provided the associated Function maintains ATWS-RPT trip capability.

{4.2.C.17}
{T 4.2.C-1}

①-1 SURVEILLANCE	FREQUENCY
{SR 3.3.4.0.1} Perform CHANNEL CHECK.	12 hours * 2

(continued)

<CTS>

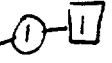

SURVEILLANCE REQUIREMENTS (continued)

SURVEILLANCE	FREQUENCY
①-① SR 3.3.4.0.2 Perform CHANNEL FUNCTIONAL TEST.	X92 days [3]
①-① X SR 3.3.4.0.3 Calibrate the trip units.	X92 days [3] (31)
①-① SR 3.3.4.0.4 Perform CHANNEL CALIBRATION. The Allowable Values shall be: a. Reactor Vessel Water Level—Low Low Level at ≥ 1.67 inches and b. Reactor Steam Dome Pressure—High: ≤ 1095 psig. Vessel	X18 months (24) [2] [3] (84) (1250)
①-① SR 3.3.4.0.5 Perform LOGIC SYSTEM FUNCTIONAL TEST including breaker actuation.	X18 months (24) [3]

<4.2.c.1>
<4.2.c-1>

<4.2.c.1>
<4.2.c-1>

<4.2.c.1>
<3.2.c-1>
<4.2.c-1>

<4.2.c.2>
<DCM.2>

with time delay set to [≥ 8 seconds and ≤ 10 seconds]; and [4]

JUSTIFICATION FOR DEVIATIONS FROM NUREG-1433, REVISION 1
ITS: 3.3.4.1 - ATWS-RPT INSTRUMENTATION

1. ISTS 3.3.4.1, End of Cycle Reactor Pump Trip (EOC-RPT) Instrumentation has been deleted since the Function is not part of the design and not required by the current licensing basis. Therefore, ISTS 3.3.4.2 has been renumbered as ITS 3.3.4.1.
2. The proper Quad Cities 1 and 2 plant specific nomenclature/value/design requirements have been provided.
3. The brackets have been removed and the proper plant specific information/value has been provided. The Surveillance Requirements have been renumbered as applicable.
4. The Reactor Vessel Water Level - Low Low Function channels include a time delay relay in the channel circuitry for each level channel. ITS SR 3.3.4.2.4.a has been revised to include the time delay to help ensure that the Reactor Vessel Water Level - Low Low Function channels provide a trip signal when necessary to satisfy the ATWS analysis.

{CTS}

3.3 INSTRUMENTATION

3.3.5.1 Emergency Core Cooling System (ECCS) Instrumentation

{3.2.B} LCO 3.3.5.1 The ECCS instrumentation for each Function in Table 3.3.5.1-1 shall be OPERABLE.

{App 3.2.B} APPLICABILITY: According to Table 3.3.5.1-1.

ACTIONS

{DOC A.3} NOTE
Separate Condition entry is allowed for each channel.

CONDITION	REQUIRED ACTION	COMPLETION TIME
<p>{3.2.B Act 1} {3.2.B Act 2}</p> <p>A. One or more channels inoperable.</p> <p>12 Required</p>	<p>A.1 Enter the Condition referenced in Table 3.3.5.1-1 for the channel.</p>	<p>Immediately</p>
<p>{T 3.2.B-1 ACTION 32}</p> <p>{T 3.2.B-1 ACTION 30}</p> <p>{T 3.2.B-1 ACTION 37}</p> <p>B. As required by Required Action A.1 and referenced in Table 3.3.5.1-1.</p>	<p>B.1</p> <p><u>NOTES</u></p> <p>1. Only applicable in MODES 1, 2, and 3.</p> <p>2. Only applicable for Functions 1.a, 1.b, 2.a, and 2.b.</p> <p>Declare supported feature(s) inoperable when its redundant feature ECCS initiation capability is inoperable.</p> <p>AND</p>	<p>1 hour from discovery of loss of initiation capability for feature(s) in both divisions</p> <p>2.d and 2.j</p> <p>1</p> <p>6</p>

⊂ (CTS)

ACTIONS

CONDITION	REQUIRED ACTION	COMPLETION TIME
<p>B. (continued)</p>	<p>B.2 <u>NOTE</u> Only applicable for Functions 3.a and 3.b.</p> <hr/> <p>Declare High Pressure Coolant Injection (HPCI) System inoperable.</p> <p>AND</p> <p>B.3 Place channel in trip.</p>	<p>1 hour from discovery of loss of HPCI initiation capability</p> <p>24 hours</p>
<p>⊂ 3.2.B1 ACTION 34</p> <p>⊂ 3.2.B1 ACTION 31</p> <p>C. As required by Required Action A.1 and referenced in Table 3.3.5.1-1.</p>	<p>C.1 <u>NOTES</u></p> <p>1. Only applicable in MODES 1, 2, and 3.</p> <p>2. Only applicable for Functions 1.c, 2.c, 2.d and 2.e. 2.f</p> <hr/> <p>Declare supported feature(s) inoperable when its redundant feature ECCS initiation capability is inoperable.</p> <p>AND</p> <p>C.2 Restore channel to OPERABLE status.</p>	<p>1 hour from discovery of loss of initiation capability for feature(s) in both divisions</p> <p>24 hours</p>

(continued)

6 (CTS)

ACTIONS (continued)

CONDITION	REQUIRED ACTION	COMPLETION TIME
<p><i>(T 3.2.B-1 ACTION 35)</i> D. As required by Required Action A.1 and referenced in Table 3.3.5.1-1.</p>	<p>D.1 <u>NOTE</u> Only applicable if HPCI pump suction is not aligned to the suppression pool.</p> <p>Declare HPCI System inoperable.</p> <p>AND</p> <p>D.2.1 Place channel in trip.</p> <p>OR</p> <p>D.2.2 Align the HPCI pump suction to the suppression pool.</p>	<p>1 hour from discovery of loss of HPCI initiation capability</p> <p>24 hours</p> <p>24 hours</p>
<p><i>(T 3.2.B-1 ACTION 33)</i> E. As required by Required Action A.1 and referenced in Table 3.3.5.1-1.</p>	<p>E.1 <u>NOTES</u></p> <p>1. Only applicable in MODES 1, 2, and 3.</p> <p>2. Only applicable for Functions 1.d and 2.g.</p> <p>Declare supported feature(s) inoperable when its redundant feature ECCS initiation capability is inoperable.</p> <p>AND</p>	<p>1 hour from discovery of loss of initiation capability for subsystems in both divisions</p> <p>(continued)</p>

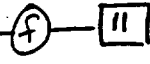

⊂ (CTS) ⊃

ACTIONS

CONDITION	REQUIRED ACTION	COMPLETION TIME
E. (continued)	E.2 Restore channel to OPERABLE status.	7 days
F. As required by Required Action A.1 and referenced in Table 3.3.5.1-1.	F.1 Declare Automatic Depressurization System (ADS) valves inoperable.	1 hour from discovery of loss of ADS initiation capability in both trip systems
	AND F.2 Place channel in trip.	96 hours from discovery of inoperable channel concurrent with HPCI or reactor core isolation cooling (RCIC) inoperable AND 8 days

⊂ T3, 2, B-1 ⊃
ACTION 3B

(continued)

6 (CTS)

ACTIONS (continued)

CONDITION	REQUIRED ACTION	COMPLETION TIME
<p><i>{ T 3.2.B-1 ACTION 31 }</i></p> <p>G. As required by Required Action A.1 and referenced in Table 3.3.5.1-1.</p>	<p>G.1 NOTE Only applicable for Functions 4.c, 4.e, 4.f, 4.g, 5.c, 5.e, 5.f, and 5.g.</p> <p>Declare ADS valves inoperable.</p> <p>AND</p> <p>G.2 Restore channel to OPERABLE status.</p>	<p style="text-align: right;">2</p> <p>1 hour from discovery of loss of ADS initiation capability in both trip systems</p> <p>96 hours from discovery of inoperable channel concurrent with HPCI or RCIC inoperable</p> <p>AND</p> <p>8 days</p>
<p><i>{ T 3.2.B-1 ACTION 32 }</i></p> <p><i>{ T 3.2.B-1 ACTION 34 }</i></p> <p><i>{ T 3.2.B-1 ACTION 31 }</i></p> <p>H. Required Action and associated Completion Time of Condition B, C, D, E, F, or G not met.</p>	<p>H.1 Declare associated supported feature(s) inoperable.</p>	<p>Immediately</p>
<p><i>{ T 3.2.B-1 ACTION 33 }</i></p> <p><i>{ T 3.2.B-1 ACTION 35 }</i></p> <p><i>{ T 3.2.B-1 ACTION 38 }</i></p>		

6 <CTS>

SURVEILLANCE REQUIREMENTS

NOTES

- 1. Refer to Table 3.3.5.1-1 to determine which SRs apply for each ECCS Function.
- 2. When a channel is placed in an inoperable status solely for performance of required Surveillances, entry into associated Conditions and Required Actions may be delayed as follows: (a) for up to 6 hours for Functions 3.c, 3.f, and 3.g; and (b) for up to 6 hours for Functions other than 3.c, 3.f, and 3.g provided the associated Function or the redundant Function maintains ECCS initiation capability.

<4.2.B.1>
<T 3.2.B-1 footnote a>

SURVEILLANCE	FREQUENCY
SR 3.3.5.1.1 Perform CHANNEL CHECK.	12 hours
SR 3.3.5.1.4 Perform CHANNEL FUNCTIONAL TEST.	92 days [3]
SR 3.3.5.1.5 Calibrate the trip unit.	92 days [3]
SR 3.3.5.1.6 Perform CHANNEL CALIBRATION.	92 days [3]
SR 3.3.5.1.7 Perform CHANNEL CALIBRATION.	18 [24] months [3]
SR 3.3.5.1.8 Perform LOGIC SYSTEM FUNCTIONAL TEST.	18 [24] months [3]
SR 3.3.5.1.7 Verify the ECCS RESPONSE TIME is within limits.	[18] months on a STAGGERED TEST BASIS [4]
SR 3.3.5.1.2 Perform CHANNEL FUNCTIONAL TEST.	31 days
SR 3.3.5.1.3 Perform CHANNEL CALIBRATION.	60 days [5]

<T 4.2.B-1>
<T 4.2.B-1 footnote e>
<T 4.2.B-1>
<T 4.2.B-1>
<T 4.2.B-1>
<T 4.2.B-1 footnote c>
<4.2.B.2>

(CTS)

T. 3.2.B-1
T. 4.2.B-1
DOC M.1

Table 3.3.5.1-1 (page 1 of 6)
Emergency Core Cooling System Instrumentation

FUNCTION	APPLICABLE MODES OR OTHER SPECIFIED CONDITIONS	REQUIRED CHANNELS PER FUNCTION	CONDITIONS REFERENCED FROM REQUIRED ACTION A.1	SURVEILLANCE REQUIREMENTS	ALLOWABLE VALUE
1. Core Spray System					
a. Reactor Vessel Water Level - Low Low (Low Level)	1,2,3, 4(a), 5(a)	X(4)(b)	B	SR 3.3.5.1.1 [≥ 27.5 inches] SR 3.3.5.1.2 SR 3.3.5.1.3 SR 3.3.5.1.4 SR 3.3.5.1.5 SR 3.3.5.1.6 SR 3.3.5.1.7	2.5
b. Drywell Pressure - High	1,2,3	X(4)(b)	B	SR 3.3.5.1.1 [≤ 10.5 psig] SR 3.3.5.1.2 SR 3.3.5.1.3 SR 3.3.5.1.4 SR 3.3.5.1.5 SR 3.3.5.1.6 SR 3.3.5.1.7	300
c. Reactor Steam Dome Pressure - Low (Inactive Permissive)	1,2,3, 4(a), 5(a)	X(4)	C	SR 3.3.5.1.1 [≥ 100 psig and ≤ 1500 psig] SR 3.3.5.1.2 SR 3.3.5.1.3 SR 3.3.5.1.4 SR 3.3.5.1.5 SR 3.3.5.1.6 SR 3.3.5.1.7	350
d. Core Spray Pump Discharge Flow - Low (Bypass)	1,2,3, 4(a), 5(a)	X(1) per pump	E	SR 3.3.5.1.1 [≥ 10 gpm and ≤ 1500 psig] SR 3.3.5.1.2 SR 3.3.5.1.3 SR 3.3.5.1.4 SR 3.3.5.1.5 SR 3.3.5.1.6 SR 3.3.5.1.7	500
e. Manual Initiation	1,2,3, 4(a), 5(a)	(2) [1 per subsystem]	C	SR 3.3.5.1.6	NA
2. Low Pressure Coolant Injection (LPCI) System					
a. Reactor Vessel Water Level - Low Low (Low Level)	1,2,3, 4(a), 5(a)	X(4)(b)	B	SR 3.3.5.1.1 [≥ 27.5 inches] SR 3.3.5.1.2 SR 3.3.5.1.3 SR 3.3.5.1.4 SR 3.3.5.1.5 SR 3.3.5.1.6 SR 3.3.5.1.7	2.5

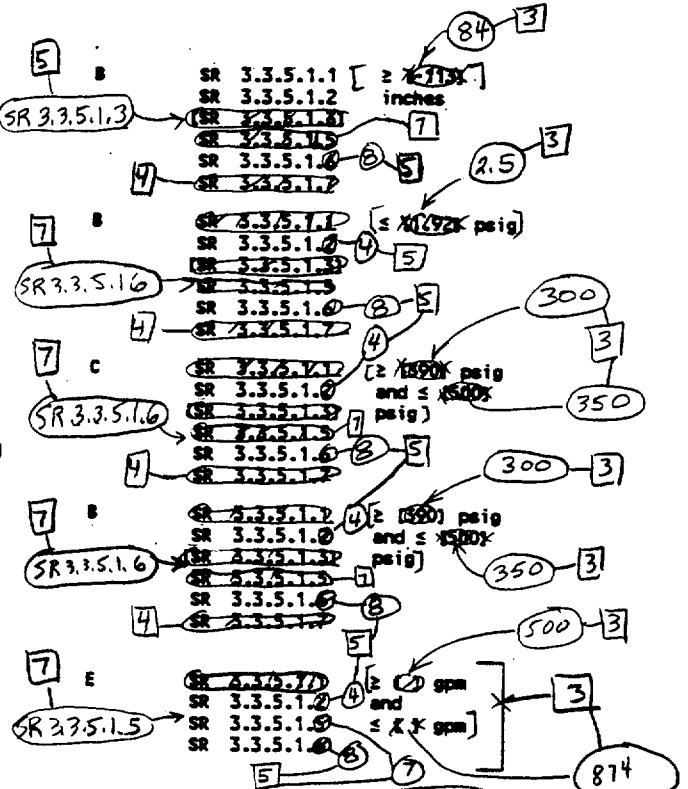
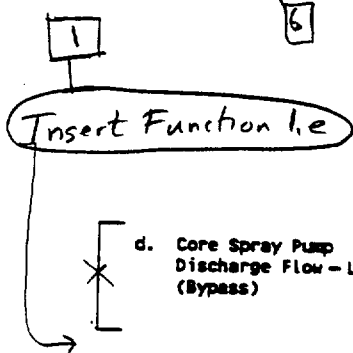

(continued)

(a) When associated subsystem(s) are required to be OPERABLE. per LCO 3.5.2, "ECCS - shutdown"

(b) Also required to initiate the associated diesel generator (DG) and isolate the associated plant service water (PSW) turbine building (T/B) isolation valves.

<CTS>



INSERT FUNCTION 1.e

e. Core Spray Pump
Start-Time Delay
Relay

1, 2, 3
4(a), 5(a)

1 per pump

C

SR 3.3.5.1.7
SR 3.3.5.1.8

≤ [10]
seconds

<DOC
M.I.>

Insert Functions 2.g, 2.h, 2.i, 2.j and 2.k

ECCS Instrumentation
3.3.5.1

<CTS>
<7.3.2.B-1>
<4.2.B-1>
<Doc M.1>

Table 3.3.5.1-1 (page 3 of 6)
Emergency Core Cooling System Instrumentation

FUNCTION	APPLICABLE MODES OR OTHER SPECIFIED CONDITIONS	REQUIRED CHANNELS PER FUNCTION	CONDITIONS REFERENCED FROM REQUIRED ACTION A.1	SURVEILLANCE REQUIREMENTS	ALLOWABLE VALUE
<p>2. LPCI System (continued)</p> <p>Low Pressure Coolant Injection Pump Discharge Flow - Low (Bypass)</p>	1,2,3, 4(a), 5(a)	X1 per loop	SR 3.3.5.1.5	SR 3.3.5.1.1, SR 3.3.5.1.2, SR 3.3.5.1.3, SR 3.3.5.1.4, SR 3.3.5.1.5, SR 3.3.5.1.6	2400 gpm
<p>h. Manual Initiation</p>	1,2,3, 4(a), 5(a)	[2] [1 per subsystem]	C	SR 3.3.5.1.6	NA

3. High Pressure Coolant Injection (HPCI) System

a. Reactor Vessel Water Level - Low Low, Level 2

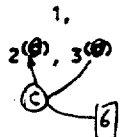

b. Drywell Pressure - High

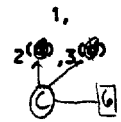

c. Reactor Vessel Water Level - High Level 3

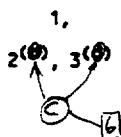

d. Condensate Storage Tank Level - Low (CCST)



e. Suppression Pool Water Level - High

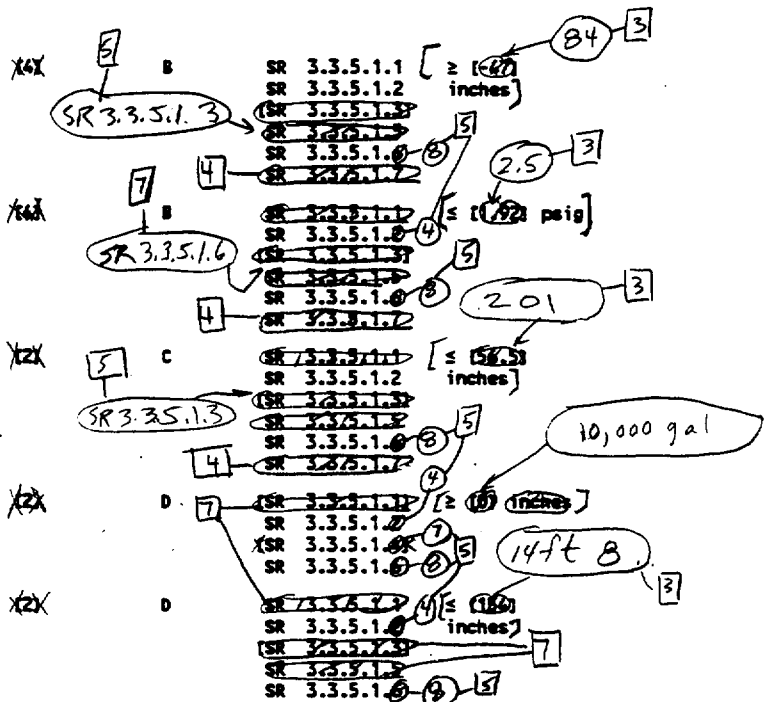
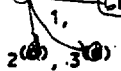

(continued)

(a) When the associated subsystem(s) are required to be OPERABLE per LCO 3.5.2

With reactor steam dome pressure > 150X psig.

1

INSERT Functions 2.g, 2.h, 2.i, 2.j, and 2.k

DOC
M.I

g.	Recirculation Pump Differential Pressure-High (Break Detection)	1, 2, 3	4 per pump	C	SR 3.3.5.1.4 SR 3.3.5.1.6 SR 3.3.5.1.8	[≤ 1.927 psid]
h.	Recirculation Riser Differential Pressure-High (Break Detection)	1, 2, 3	4	C	SR 3.3.5.1.4 SR 3.3.5.1.6 SR 3.3.5.1.8	[≤ 1.0 psid]
i.	Recirculation Pump Differential Pressure Time Delay - Relay (Break Detection)	1, 2, 3	2	C	SR 3.3.5.1.7 SR 3.3.5.1.8	≤ [1.0] seconds
j.	Reactor Steam Dome Pressure Time Delay - Relay (Break Detection)	1, 2, 3	2	B	SR 3.3.5.1.7 SR 3.3.5.1.8	≤ [2.25] seconds
k.	Recirculation Riser Differential Pressure Time Delay - Relay (Break Detection)	1, 2, 3	2	C	SR 3.3.5.1.7 SR 3.3.5.1.8	≤ [1.0] seconds

<CTS>

ECCS Instrumentation
3.3.5.1

<3.2.B-1>
<4.2.B-1>

Table 3.3.5.1-1 (page 4 of 6)
Emergency Core Cooling System Instrumentation

FUNCTION	APPLICABLE MODES OR OTHER SPECIFIED CONDITIONS	REQUIRED CHANNELS PER FUNCTION	CONDITIONS REFERENCED FROM REQUIRED ACTION A.1	SURVEILLANCE REQUIREMENTS	ALLOWABLE VALUE
3. HPCI System (continued)					
f. High Pressure Coolant Injection Pump Discharge Flow - Low (Bypass)	1, 2(1), 3(1)	X1X	E	SR 3.3.5.1.1, SR 3.3.5.1.2, SR 3.3.5.1.3, SR 3.3.5.1.4	200, 3
g. Manual Initiation	1, 2(2), 3(2)	X1X	C	SR 3.3.5.1.5	NA
4. Automatic Depressurization System (ADS) Trip System A					
a. Reactor Vessel Water Level - Low Low (Level 1)	1, 2(1), 3(1)	X2X	F	SR 3.3.5.1.1, SR 3.3.5.1.2, SR 3.3.5.1.3, SR 3.3.5.1.4, SR 3.3.5.1.5, SR 3.3.5.1.6	84, 3
b. Drywell Pressure - High	1, 2(1), 3(1)	X2X	F	SR 3.3.5.1.1, SR 3.3.5.1.2, SR 3.3.5.1.3, SR 3.3.5.1.4, SR 3.3.5.1.5, SR 3.3.5.1.6	2.5, 3
c. Automatic Depressurization System Initiation Timer	1, 2(1), 3(1)	X1X	G	SR 3.3.5.1.1, SR 3.3.5.1.2	120, 3
d. Reactor Vessel Water Level - Low, Level 3 (Confirmatory)	1, 2(d), 3(d)	[1]	F	SR 3.3.5.1.1, SR 3.3.5.1.2, SR 3.3.5.1.3, SR 3.3.5.1.5, SR 3.3.5.1.6	10, 3
e. Core Spray Pump Discharge Pressure - High	1, 2(1), 3(1)	X2X	G	SR 3.3.5.1.1, SR 3.3.5.1.2, SR 3.3.5.1.3, SR 3.3.5.1.4, SR 3.3.5.1.5, SR 3.3.5.1.6	100, 150, 3

(1) With reactor steam dome pressure > 150 psig.



(CTS)

(T 3.2.B-1)
(T 4.2.B-1)

ECCS Instrumentation
3.3.5.1

Table 3.3.5.1-1 (page 5 of 6)
Emergency Core Cooling System Instrumentation

FUNCTION	APPLICABLE MODES OR OTHER SPECIFIED CONDITIONS	REQUIRED CHANNELS PER FUNCTION	CONDITIONS REFERENCED FROM REQUIRED ACTION A.1	SURVEILLANCE REQUIREMENTS	ALLOWABLE VALUE
<p>4. ADS Trip System A (continued)</p> <p>Low Pressure Coolant Injection Pump Discharge Pressure - High</p> <p>Automatic Depressurization System Low Water Level Actuation Timer</p>	<p>1, 2, 3</p> <p>1, 2, 3</p>	<p>3</p> <p>X2X</p> <p>X2X</p>	<p>G</p> <p>G</p>	<p>SR 3.3.5.1.6</p> <p>SR 3.3.5.1.6</p> <p>SR 3.3.5.1.6</p> <p>SR 3.3.5.1.6</p> <p>SR 3.3.5.1.6</p> <p>SR 3.3.5.1.6</p>	<p>≥ 120 psig and ≤ 150 psig</p> <p>≤ 120 minutes</p>
<p>h. Manual Initiation</p>	<p>1, 2(d), 3(d)</p>	<p>2</p>	<p>G</p>	<p>SR 3.3.5.1.6</p>	<p>NA</p>
<p>5. ADS Trip System B</p> <p>a. Reactor Vessel Water Level - Low Low Level</p> <p>b. Drywell Pressure - High</p> <p>c. Automatic Depressurization System Initiation Timer</p> <p>d. Reactor Vessel Water Level - Low, Level 3 (Confirmatory)</p> <p>e. Core Spray Pump Discharge Pressure - High</p>	<p>1, 2, 3</p> <p>1, 2, 3</p> <p>1, 2, 3</p> <p>1, 2, 3</p> <p>1, 2, 3</p>	<p>X2X</p> <p>X2X</p> <p>X1X</p> <p>[1]</p> <p>X2X</p>	<p>F</p> <p>F</p> <p>G</p> <p>F</p> <p>G</p>	<p>SR 3.3.5.1.1</p> <p>SR 3.3.5.1.2</p> <p>SR 3.3.5.1.3</p> <p>SR 3.3.5.1.4</p> <p>SR 3.3.5.1.5</p> <p>SR 3.3.5.1.6</p> <p>SR 3.3.5.1.1</p> <p>SR 3.3.5.1.2</p> <p>[SR 3.3.5.1.3]</p> <p>SR 3.3.5.1.5</p> <p>SR 3.3.5.1.6</p> <p>SR 3.3.5.1.1</p> <p>SR 3.3.5.1.2</p> <p>SR 3.3.5.1.3</p> <p>SR 3.3.5.1.5</p> <p>SR 3.3.5.1.6</p> <p>SR 3.3.5.1.6</p> <p>SR 3.3.5.1.6</p> <p>SR 3.3.5.1.6</p> <p>SR 3.3.5.1.6</p>	<p>≥ 115 inches</p> <p>≤ 120 psig</p> <p>≤ 120 seconds</p> <p>≥ 10 inches</p> <p>≥ 120 psig and ≤ 150 psig</p>

(a) With reactor steam dome pressure > 1500 psig.

< CTS >

< T 3.2.B-1 >
< T 4.2.B-1 >

Table 3.3.5.1-1 (page 6 of 6)
Emergency Core Cooling System Instrumentation

FUNCTION	APPLICABLE MODES OR OTHER SPECIFIED CONDITIONS	REQUIRED CHANNELS PER FUNCTION	CONDITIONS REFERENCED FROM REQUIRED ACTION A.1	SURVEILLANCE REQUIREMENTS	ALLOWABLE VALUE
5. ADS Trip System B (continued) Low Pressure Coolant Injection Pump Discharge Pressure - High Automatic Depressurization System Low Water Level Actuation Timer		1, 2, 3	SR 3.3.5.1.4 SR 3.3.5.1.0 SR 3.3.5.1.3 SR 3.3.5.1.0 SR 3.3.5.1.0 SR 3.3.5.1.0	[2, 100 psig and < 10 psig] [0, 230 minutes]	3 3 3
h. Manual Initiation	1, 2(d), 3(d)	2	SR 3.3.5.1.6	NA	2

With reactor steam dome pressure > 150 psig.

JUSTIFICATION FOR DEVIATIONS FROM NUREG-1433, REVISION 1
ITS: 3.3.5.1 - ECCS INSTRUMENTATION

1. Six new ECCS Functions have been added to ISTS Table 3.3.5.1-1. ITS Function 1.e, CS Pump Start-Time Delay Relay, is associated with the CS subsystem. The other Functions have been added to ensure the Loop Select Logic of the LPCI System functions properly. These Functions are ITS Functions 2.g, 2.h, 2.i, 2.j, and 2.k. Since these Functions have been added, Note 2 to Required Action B.1 and Note 2 to Required Action C.1 have been revised.
2. The current Quad Cities 1 and 2 design does not include a and CS, LPCI or ADS Manual Initiation Instrumentation Function. Therefore, ISTS 3.3.5.1 Functions 1.e, 2.h, 4.h and 5.h have been deleted. In addition, the ISTS 3.3.5.1 Required Action G.1 Note has been deleted since the Required Action now applies to each of the Functions that reference Condition G.
3. The brackets have been removed and the proper plant specific information/value has been provided.
4. ISTS SR 3.3.5.1.7 has been deleted consistent with current licensing basis requirements.
5. Two new Surveillance Requirements have been added for performance of a CHANNEL FUNCTIONAL TEST once per 31 days and a CHANNEL CALIBRATION once per 60 days (ITS SR 3.3.5.1.2 and ITS SR 3.3.5.1.3, respectively) consistent with the current licensing basis. Subsequent SRs have been renumbered, as required
6. The proper Quad Cities 1 and 2 plant specific nomenclature/value/design requirements have been provided. Note 2 to Required Action B.1 and Note 2 to Required Action C.1 have been revised accordingly. Table 3.3.5.1-1 Footnotes have been renumbered, as required.
7. The Surveillance Requirements associated with specific Functions in ISTS Table 3.3.5.1-1 have been revised to be consistent with the current licensing basis or with the setpoint calculation methodology.
8. Footnote (a) to ITS Table 3.3.5.1-1 has been modified to only require the ECCS Instrumentation Functions to be Operable when the associated ECCS subsystem(s) are required to be Operable per LCO 3.5.2, "ECCS—Shutdown." Some of the Functions (ITS Table 3.3.5.1-1 Functions 1.a and 1.b) start the DGs in addition to the ECCS subsystems. This is shown in Footnote (b) to Table 3.3.5.1-1. As written, the ISTS implies that these Functions are required to be Operable when the DGs are required, even if the associated ECCS subsystems are not required. During shutdown Modes when the reactor cavity is flooded, the ECCS subsystems are not required to be Operable. Therefore, the ECCS start function of the DGs serve no safety significant support function. As such, these instrument Functions are not required and have been

JUSTIFICATION FOR DEVIATIONS FROM NUREG-1433, REVISION 1
ITS: 3.3.5.1 - ECCS INSTRUMENTATION

8. (continued)

deleted from the ITS when only the DGs are required to be Operable. This change is also consistent with current licensing basis (CTS Table 3.3.3-1 Footnote * only requires these Functions when the system is required to be Operable per CTS 3.5.B, the ECCS—Shutdown Specification). The DGs are still required to be started on a loss of power signal, as required in ITS 3.3.8.1.

9. ISTS Table 3.3.5.1-1 Function 2.e requires a minimum time for the ECCS pump start time delay relays. The ISTS Bases states that the minimum time is to ensure that excess loading will not cause failure of the power source; i.e., the minimum Allowable Value is chosen to be long enough so that most of the starting transient of the first pump is complete before starting the second pump on the same 4.16 kV emergency bus. Failure of this portion of the instrumentation will result in the DG or offsite circuit being inoperable; it does not necessarily result in the inoperability of the ECCS pump. The ECCS analysis assumes the pumps are operating at a certain time; starting the pumps sooner than assumed does not invalidate the ECCS analysis. This requirement is adequately covered by ITS SR 3.8.1.18, which requires the interval between each sequenced load block to be within $\pm 10\%$ of the design interval for each load sequence time delay relay. The ITS Bases for this SR states that it ensures that a sufficient time interval exists for the DG to restore frequency and voltage prior to applying the next load and that safety analyses assumptions regarding ESF equipment time delays are not violated. Therefore, if a time delay relay actuated too soon such that a power source was affected, the requirements of SR 3.8.1.18 would not be met and the affected DG or offsite circuit would be declared inoperable and the ACTIONS of ITS 3.8.1 taken. Therefore, there is no reason to require minimum times in the ECCS Instrumentation Specification. This is also consistent with current licensing basis, which does not have minimum time requirements for the ECCS pump start time delay relays in the ECCS Instrumentation Specification.
10. The current Quad Cities 1 and 2 design does not include the ADS Reactor Vessel Water Level—Low, Level 3 (Confirmatory) Function (ISTS Functions 4.d and 5.d). Therefore, these Functions have been deleted and the remaining Functions have been renumbered, where applicable, to reflect these deletions.
11. ISTS Table 3.3.5.1-1 Function 2.e, Reactor Vessel Shroud Level—Level 0, has been relocated as documented in the Discussion of Changes for ITS 3.3.5.1. Subsequent Functions have been renumbered as required.
12. The word "required" has been added consistent with its use throughout the ITS (not all CCST channels are required in the LCO).

<CTS>

3.3 INSTRUMENTATION

3.3.5.2 Reactor Core Isolation Cooling (RCIC) System Instrumentation

<3.2.D> LCO 3.3.5.2 The RCIC System instrumentation for each Function in Table 3.3.5.2-1 shall be OPERABLE.

<App 3.2.D> APPLICABILITY: MODE 1, MODES 2 and 3 with reactor steam dome pressure > ~~X150~~ psig. 1

ACTIONS

<DOCA.2> NOTE
Separate Condition entry is allowed for each channel.

CONDITION	7 REQUIRED ACTION	COMPLETION TIME
<3.2.D Act 1> <3.2.D Act 2> A. One or more ^{required} channels inoperable.	A.1 Enter the Condition referenced in Table 3.3.5.2-1 for the channel.	Immediately
<T 3.2.D-1 ACTION 40> B. As required by Required Action A.1 and referenced in Table 3.3.5.2-1.	B.1 Declare RCIC System inoperable.	1 hour from discovery of loss of RCIC initiation capability
	AND B.2 Place channel in trip.	24 hours
<T 3.2.D-1 ACTION 41> <T 3.2.D-1 ACTION 43> C. As required by Required Action A.1 and referenced in Table 3.3.5.2-1.	C.1 Restore channel to OPERABLE status.	24 hours

(continued)

← (CTS)

RCIC System Instrumentation
3.3.5.2

ACTIONS (continued)

{ T 3.2.0-1
ACTION 42 }

CONDITION	REQUIRED ACTION	COMPLETION TIME	
D. As required by Required Action A.1 and referenced in Table 3.3.5.2-1.	D.1 NOTE Only applicable if RCIC pump suction is not aligned to the suppression pool.	1 hour from discovery of loss of RCIC initiation capability	
	Declare RCIC System inoperable.		
	<u>AND</u> D.2.1 Place channel in trip.		24 hours
	<u>OR</u> D.2.2 Align RCIC pump suction to the suppression pool.	24 hours	
E. Required Action and associated Completion Time of Condition B, C, or D not met.	E.1 Declare RCIC System inoperable.	Immediately	

{ T 3.2.0-1
ACTION 41 }

{ T 3.2.0-1
ACTION 43 }

{ T 3.2.0-1
ACTION 40 }

{ T 3.2.0-1
ACTION 42 }

(CTS)

SURVEILLANCE REQUIREMENTS

NOTES

(4.2.D.1)

1. Refer to Table 3.3.5.2-1 to determine which SRs apply for each RCIC Function.

(3.2.D.1)
Note a

2. When a channel is placed in an inoperable status solely for performance of required Surveillances, entry into associated Conditions and Required Actions may be delayed as follows: (a) for up to 6 hours for Functions 2 and 5; and (b) for up to 6 hours for Functions 1, 3, and 4 provided the associated Function maintains RCIC initiation capability.

SURVEILLANCE	FREQUENCY
SR 3.3.5.2.1 Perform CHANNEL CHECK.	12 hours
SR 3.3.5.2.2 Perform CHANNEL FUNCTIONAL TEST.	92 days
SR 3.3.5.2.3 Calibrate the trip units.	[92] days
SR 3.3.5.2.4 Perform CHANNEL CALIBRATION.	92 days
SR 3.3.5.2.5 Perform CHANNEL CALIBRATION.	18 months
SR 3.3.5.2.6 Perform LOGIC SYSTEM FUNCTIONAL TEST.	18 months

(4.2.D-1)

(4.2.D-1)

3

SR 3.3.5.2.3 Calibrate the trip units. [92] days

SR 3.3.5.2.4 Perform CHANNEL CALIBRATION. 92 days

(4.2.D-1)

SR 3.3.5.2.5 Perform CHANNEL CALIBRATION. ~~18~~ months

(4.2.D.2)

SR 3.3.5.2.6 Perform LOGIC SYSTEM FUNCTIONAL TEST. ~~18~~ months

(4.2.D-1)

SR 3.3.5.2.2 Perform CHANNEL FUNCTIONAL TEST. 31 days

SR 3.3.5.2.3 Perform CHANNEL CALIBRATION. 60 days

{CTS}

RCIC System Instrumentation
3.3.5.2

{T 3.2.D-1}
{T 4.2.D-1}

Table 3.3.5.2-1 (page 1 of 1)
Reactor Core Isolation Cooling System Instrumentation

FUNCTION	REQUIRED CHANNELS PER FUNCTION	CONDITIONS REFERENCED FROM REQUIRED ACTION A.1	SURVEILLANCE REQUIREMENTS	ALLOWABLE VALUE
1. Reactor Vessel Water Level - Low Low <u>Level 2</u>	X4X	B	SR 3.3.5.2.1 SR 3.3.5.2.2 SR 3.3.5.2.3 SR 3.3.5.2.5 SR 3.3.5.2.6	\geq 67 inches 84 201
2. Reactor Vessel Water Level - High <u>Level 8</u>	X2X	C	SR 3.3.5.2.1 SR 3.3.5.2.2 SR 3.3.5.2.3 SR 3.3.5.2.5 SR 3.3.5.2.6	\leq X66.9X inches 598ft ± E7
3. Contaminated Condensate Storage Tank Level - Low (CCST)	X2X	D	SR 3.3.5.2.1 SR 3.3.5.2.2 SR 3.3.5.2.3 XSR 3.3.5.2.4 SR 3.3.5.2.6	\geq 14 inches 14ft ± 8
4. Suppression Pool Water Level - High	X2X	D	SR 3.3.5.2.1 SR 3.3.5.2.2 SR 3.3.5.2.3 SR 3.3.5.2.5 SR 3.3.5.2.6	\geq X113X inches
5. Manual Initiation	Y1X	C	SR 3.3.5.2.6	NA

JUSTIFICATION FOR DEVIATIONS FROM NUREG-1433, REVISION 1
ITS: 3.3.5.2 - RCIC SYSTEM INSTRUMENTATION

1. The brackets have been removed and the proper plant specific information/value has been provided.
2. ITS SR 3.3.5.2.2, requiring performance of a CHANNEL FUNCTIONAL TEST once every 31 days, and SR 3.3.5.2.3, requiring performance of a CHANNEL CALIBRATION once per 60 days, have been added consistent with the current licensing basis. Subsequent SRs are renumbered, as required.
3. The bracketed Surveillance has been deleted since it does not apply to Quad Cities RCIC System Instrumentation. Subsequent SRs have been renumbered as required.
4. The Surveillance Requirements associated with ITS Table 3.3.5.2-1 Functions have been revised to reflect current licensing basis requirements.
5. The bracketed Surveillance (the requirement to perform a CHANNEL CHECK) has been deleted from Table 3.3.5.2-1 Functions 3 and 4 since CHANNEL CHECKS can not be performed on these channels at Quad Cities 1 and 2.
6. The proper Quad Cities 1 and 2 Instrument title has been used.
7. The word "required" has been added consistent with its use throughout the ITS (not all CCST channels are required in the LCO).

(CTS)

Primary Containment Isolation Instrumentation
3.3.6.1

3.3 INSTRUMENTATION

3.3.6.1 Primary Containment Isolation Instrumentation

{3.2.A}

LCO 3.3.6.1 The primary containment isolation instrumentation for each Function in Table 3.3.6.1-1 shall be OPERABLE.

{Appl 3.2.A} APPLICABILITY: According to Table 3.3.6.1-1.

ACTIONS

{DOC A.2}

NOTE
Separate Condition entry is allowed for each channel.

{3.2.A Action 1}

{3.2.A Action 2}

{3.2.A Action 1}

3.2.A Action 2

CONDITION	REQUIRED ACTION	COMPLETION TIME
A. One or more required channels inoperable.	A.1 Place channel in trip.	12 hours for Functions (2.a, 2.b, and 6.b) AND 24 hours for Functions other than Functions 2.a, 2.b, and 6.b.
B. One or more automatic Functions with isolation capability not maintained.	B.1 Restore isolation capability.	1 hour

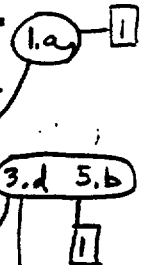

(continued)

↳ (CTS)

Primary Containment Isolation Instrumentation
3.3.6.1

ACTIONS (continued)

CONDITION	REQUIRED ACTION	COMPLETION TIME
<p>3.2.A Action 2</p> <p>C. Required Action and associated Completion Time of Condition A or B not met.</p>	<p>C.1 Enter the Condition referenced in Table 3.3.6.1-1 for the channel.</p>	<p>Immediately</p>
<p>↳ T 3.2.A-1 ACTION 21</p> <p>D. As required by Required Action C.1 and referenced in Table 3.3.6.1-1.</p>	<p>D.1 Isolate associated main steam line (MSL).</p> <p><u>OR</u></p> <p>D.2.1 Be in MODE 3.</p> <p><u>AND</u></p> <p>D.2.2 Be in MODE 4.</p>	<p>12 hours</p> <p>12 hours</p> <p>36 hours</p>
<p>↳ T 3.2.A-1 ACTION 22</p> <p>E. As required by Required Action C.1 and referenced in Table 3.3.6.1-1.</p>	<p>E.1 Be in MODE 2.</p>	<p>8 hours</p> <p>Ⓟ — 2</p>
<p>↳ T 3.2.A-1 ACTION 23</p> <p>F. As required by Required Action C.1 and referenced in Table 3.3.6.1-1.</p>	<p>F.1 Isolate the affected penetration flow path(s).</p>	<p>1 hour</p>
<p>G. As required by Required Action C.1 and referenced in Table 3.3.6.1-1.</p>	<p>G.1 Isolate the affected penetration flow path(s).</p>	<p>24 hours</p> <p>Ⓟ — 3</p>

(continued)

6(CTS)

Primary Containment Isolation Instrumentation
3.3.6.1

ACTIONS (continued)

	CONDITION	REQUIRED ACTION	COMPLETION TIME
<p>3</p> <p>G</p> <p>4</p> <p>(T 3.2.A-1 ACTION 20)</p>	<p>F. As required by Required Action C.1 and referenced in Table 3.3.6.1-1.</p> <p>OR</p> <p>Required Action and associated Completion Time for Condition F G not met.</p>	<p>G.1 Be in MODE 3.</p> <p>AND G-3</p> <p>G.2 Be in MODE 4.</p>	<p>12 hours</p> <p>36 hours</p>
<p>3</p> <p>H</p> <p>(T 3.2.A-1 ACTION 23)</p>	<p>As required by Required Action C.1 and referenced in Table 3.3.6.1-1.</p>	<p>H.1 Declare associated standby liquid control subsystem (SLC) inoperable.</p> <p>OR</p> <p>H.2 Isolate the Reactor Water Cleanup System.</p>	<p>1 hour</p> <p>1 hour</p>
<p>3</p> <p>I</p> <p>(T 3.2.A-1 ACTION 23)</p> <p>(DOC. L.3)</p>	<p>As required by Required Action C.1 and referenced in Table 3.3.6.1-1.</p>	<p>I.1 Initiate action to restore channel to OPERABLE status.</p> <p>OR</p> <p>I.2 Initiate action to isolate the Residual Heat Removal (RHR) Shutdown Cooling System.</p>	<p>Immediately</p> <p>Immediately</p>

6 <CTS>

Primary Containment Isolation Instrumentation
3.3.6.1

SURVEILLANCE REQUIREMENTS

NOTES

1. Refer to Table 3.3.6.1-1 to determine which SRs apply for each Primary Containment Isolation Function.
2. When a channel is placed in an inoperable status solely for performance of required Surveillances, entry into associated Conditions and Required Actions may be delayed for up to 6 hours provided the associated Function maintains isolation capability.

SURVEILLANCE	FREQUENCY
SR 3.3.6.1.1 Perform CHANNEL CHECK.	12 hours
SR 3.3.6.1.2 Perform CHANNEL FUNCTIONAL TEST.	92 days [5]
SR 3.3.6.1.3 Calibrate the trip unit.	92 days [5] ← [5]
SR 3.3.6.1.4 Perform CHANNEL CALIBRATION.	92 days
SR 3.3.6.1.5 Perform CHANNEL FUNCTIONAL TEST.	[184] days [3]
SR 3.3.6.1.6 Perform CHANNEL CALIBRATION.	12 months (24) [5]
SR 3.3.6.1.7 Perform LOGIC SYSTEM FUNCTIONAL TEST.	12 months (24) [5]

(continued)

6 (ETS)

Primary Containment Isolation Instrumentation
3.3.6.1

SURVEILLANCE REQUIREMENTS (continued)

SURVEILLANCE	FREQUENCY
<p>SR 3.3.6.1.8</p> <p>NOTE Radiation detectors may be excluded.</p> <p>Verify the ISOLATION SYSTEM RESPONSE TIME is within limits.</p> <p>Reviewer's Note: This SR is applied only to Functions of Table 3.3.6.1-1 with required response times not corresponding to DG start time.</p>	<p>[18] months on a STAGGERED TEST BASIS</p>

6

<CTS>

<T 3.2.A-1>
 <T 4.2.A-1>
 <DOC M.1>

Primary Containment Isolation Instrumentation
 3.3.6.1

Table 3.3.6.1-1 (page 1 of 6)
 Primary Containment Isolation Instrumentation

FUNCTION	APPLICABLE NODES OR OTHER SPECIFIED CONDITIONS	REQUIRED CHANNELS PER TRIP SYSTEM	CONDITIONS REFERENCED FROM REQUIRED ACTION C.1	SURVEILLANCE REQUIREMENTS	ALLOWABLE VALUE
1. Main Steam Line Isolation					
a. Reactor Vessel Water Level - Low Low	1,2,3	2 ⁵	D	SR 3.3.6.1.1 [≥ 7.5 inches] SR 3.3.6.1.2 [≥ 7.5 inches] SR 3.3.6.1.3 SR 3.3.6.1.4 SR 3.3.6.1.6 SR 3.3.6.1.7	84, 5
b. Main Steam Line Pressure - Low	1	2 ⁵	E	SR 3.3.6.1.1 [≥ 1825 psig] SR 3.3.6.1.2 SR 3.3.6.1.4 SR 3.3.6.1.6 SR 3.3.6.1.7	140, 5
c. Main Steam Line Flow - High	1,2,3	2 per NCL ⁵	D	SR 3.3.6.1.1 [$\leq 100\%$ rated steam flow] SR 3.3.6.1.2 [$\leq 100\%$ rated steam flow] SR 3.3.6.1.3 SR 3.3.6.1.4 SR 3.3.6.1.6 SR 3.3.6.1.7	5, 3, 4, 6
d. Condenser Vacuum - Low	2(a), 3(a)	2	D	SR 3.3.6.1.1 [≥ 7 inches Hg vacuum] SR 3.3.6.1.2 [≥ 7 inches Hg vacuum] SR 3.3.6.1.4 [≥ 7 inches Hg vacuum] SR 3.3.6.1.7 [≥ 7 inches Hg vacuum]	3
e. Main Steam Tunnel Temperature - High	1,2,3	2 ⁵ 2 per trip string	D	SR 3.3.6.1.1 [≤ 200 °F] SR 3.3.6.1.2 [≤ 200 °F] SR 3.3.6.1.3 SR 3.3.6.1.4 SR 3.3.6.1.6 SR 3.3.6.1.7	200, 5
f. Main Steam Tunnel Differential Temperature - High	1,2,3	2	D	SR 3.3.6.1.1 [≤ 1 °F] SR 3.3.6.1.2 [≤ 1 °F] SR 3.3.6.1.3 SR 3.3.6.1.6 SR 3.3.6.1.7	3
g. Turbine Building Area Temperature - High	1,2,3	2	E	[SR 3.3.6.1.1] [≤ 200 °F] SR 3.3.6.1.2 [≤ 200 °F] SR 3.3.6.1.6 SR 3.3.6.1.7	
h. Manual Initiation	1,2,3	1	G	SR 3.3.6.1.7 NA	

(a) With ~~any~~ turbine [stop valve] not closed. 3

(continued)

BWR/4 STS

3.3-57

Rev 1, 04/07/95

c. Main Steam Line Pressure - Timer 1 2 E SR 3.3.6.1.2 [≥ 0.1 seconds and ≤ 0.5 seconds]
 SR 3.3.6.1.4
 SR 3.3.6.1.6

3

E <CTS>

Primary Containment Isolation Instrumentation
3.3.6.1

4 3.2.A-1
4 4.2.A-1
(DOC M.4)

Table 3.3.6.1-1 (page 2 of 6)
Primary Containment Isolation Instrumentation

FUNCTION	APPLICABLE NODES OR OTHER SPECIFIED CONDITIONS	REQUIRED CHANNELS PER TRIP SYSTEM	CONDITIONS REFERENCED FROM REQUIRED ACTION C.1	SURVEILLANCE REQUIREMENTS	ALLOWABLE VALUE
2. Primary Containment Isolation					
a. Reactor Vessel Water Level - Low	1,2,3	X2K		SR 3.3.6.1.1 [≥ 100 inches] SR 3.3.6.1.2 SR 3.3.6.1.3 SR 3.3.6.1.4 SR 3.3.6.1.5 SR 3.3.6.1.6	144 [5] ≤ 2.5 [5]
b. Drywell Pressure - High	1,2,3	X2K		SR 3.3.6.1.7 [≤ 11.92 psig] SR 3.3.6.1.8 SR 3.3.6.1.9 SR 3.3.6.1.0 SR 3.3.6.1.1 SR 3.3.6.1.2 SR 3.3.6.1.3 SR 3.3.6.1.4 SR 3.3.6.1.5 SR 3.3.6.1.6	10 add SR 3.3.6.1.4 100 [5]
c. Drywell Radiation - High	1,2,3	X1K	F	SR 3.3.6.1.1 [≤ 1000 R/hr] SR 3.3.6.1.2 SR 3.3.6.1.3 SR 3.3.6.1.4 SR 3.3.6.1.5 SR 3.3.6.1.6	100 [5]
d. Reactor Building Exhaust Radiation - High	1,2,3	[2]	H	SR 3.3.6.1.1 ≤ (60) mR/hr SR 3.3.6.1.2 SR 3.3.6.1.6 SR 3.3.6.1.7 SR 3.3.6.1.8	[3]
e. Refueling Floor Exhaust Radiation - High	1,2,3	[2]	H	SR 3.3.6.1.1 ≤ (20) mR/hr SR 3.3.6.1.2 SR 3.3.6.1.6 SR 3.3.6.1.7 SR 3.3.6.1.8	
f. Manual Initiation	1,2,3	[1 per group]	G	SR 3.3.6.1.7 MA	
3. High Pressure Coolant Injection (NPCI) System Isolation					
a. NPCI Steam Line Flow - High	1,2,3	X1K	F	SR 3.3.6.1.1 [≤ 100% rated steam flow] SR 3.3.6.1.2 SR 3.3.6.1.3 SR 3.3.6.1.4 SR 3.3.6.1.5 SR 3.3.6.1.6 SR 3.3.6.1.7 SR 3.3.6.1.8	300 [5]

Insert Function 3.b [3]

(continued)

<CTS>

3

Insert Function 3.b

b. HPCI Steam Line
Flow-Timer

1, 2, 3

1

F

SR 3.3.6.1.2

SR 3.3.6.1.4

SR 3.3.6.1.6

≥ [3] seconds

and ≤ [9]

seconds

DOC
M.4

E <CTS>

(T 3.2.A-1)

(T 4.2.A-1)

(DOC M.2)

Primary Containment Isolation Instrumentation
3.3.6.1

Table 3.3.6.1-1 (page 3 of 6)
Primary Containment Isolation Instrumentation

FUNCTION	APPLICABLE MODES OR OTHER SPECIFIED CONDITIONS	REQUIRED CHANNELS PER TRIP SYSTEM	CONDITIONS REFERENCED FROM REQUIRED ACTION C.1	SURVEILLANCE REQUIREMENTS	ALLOWABLE VALUE
3.NPCI System Isolation (continued)					
<p>3</p> <p>3 NPCI Steam Supply Line Pressure - Low</p>	1,2,3	5 22	F	<p>SR 3.3.6.1.1 [\geq 100 psig]</p> <p>SR 3.3.6.1.2</p> <p>SR 3.3.6.1.3</p> <p>SR 3.3.6.1.6</p> <p>SR 3.3.6.1.7</p>	5
<p>c. NPCI Turbine Exhaust Diaphragm Pressure - High</p>	1,2,3	2	F	<p>SR 3.3.6.1.1</p> <p>SR 3.3.6.1.2</p> <p>SR 3.3.6.1.3</p> <p>SR 3.3.6.1.6</p> <p>SR 3.3.6.1.7</p>	5 [20] psig
<p>d. Drywell Pressure - High</p>	1,2,3	2	F	<p>SR 3.3.6.1.3</p> <p>SR 3.3.6.1.2</p> <p>SR 3.3.6.1.3</p> <p>SR 3.3.6.1.6</p> <p>SR 3.3.6.1.7</p>	5 [17.5] psig
<p>e. NPCI Pipe Penetration Area Temperature - High</p> <p>Turbine Area</p>	1,2,3	2	F	<p>SR 3.3.6.1.3</p> <p>SR 3.3.6.1.2</p> <p>SR 3.3.6.1.3</p> <p>SR 3.3.6.1.6</p> <p>SR 3.3.6.1.7</p>	5 [170] °F
<p>f. Suppression Pool Area Ambient Temperature - High</p>	1,2,3	[1]	F	<p>SR 3.3.6.1.1</p> <p>SR 3.3.6.1.2</p> <p>SR 3.3.6.1.3</p> <p>SR 3.3.6.1.6</p> <p>SR 3.3.6.1.7</p>	5 [169] °F
<p>g. Suppression Pool Area Temperature - Time Delay Relays</p>	1,2,3	[1]	F	<p>SR 3.3.6.1.5</p> <p>SR 3.3.6.1.6</p> <p>SR 3.3.6.1.7</p>	3 \geq [NA] [minutes]
<p>h. Suppression Pool Area Differential Temperature - High</p>	1,2,3	[1]	F	<p>SR 3.3.6.1.1</p> <p>SR 3.3.6.1.2</p> <p>SR 3.3.6.1.3</p> <p>SR 3.3.6.1.6</p> <p>SR 3.3.6.1.7</p>	5 \leq [42] °F
<p>i. Emergency Area Cooler Temperature - High</p>	1,2,3	[1]	F	<p>SR 3.3.6.1.1</p> <p>SR 3.3.6.1.2</p> <p>SR 3.3.6.1.3</p> <p>SR 3.3.6.1.6</p> <p>SR 3.3.6.1.7</p>	5 \leq [169] °F
<p>j. Manual Initiation</p>	1,2,3	[1 per group]	G	SR 3.3.6.1.7	NA

(continued)

Primary Containment Isolation Instrumentation
3.3.6.1

Table 3.3.6.1-1 (page 4 of 6)
Primary Containment Isolation Instrumentation

FUNCTION	APPLICABLE MODES OR OTHER SPECIFIED CONDITIONS	REQUIRED CHANNELS PER TRIP SYSTEM	CONDITIONS REFERENCED FROM REQUIRED ACTION C.1	SURVEILLANCE REQUIREMENTS	ALLOWABLE VALUE
----------	--	-----------------------------------	--	---------------------------	-----------------

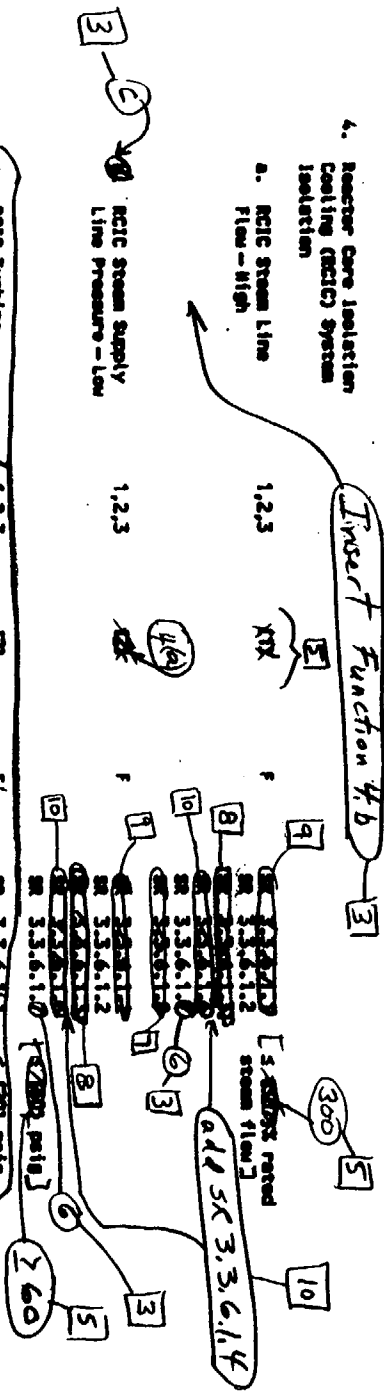

a. Reactor Core Isolation Cooling (RCIC) System Isolation					
a. RCIC Steam Line Flow - High	1,2,3	RTX	F	SR 3.3.6.1.2 SR 3.3.6.1.3 SR 3.3.6.1.4 SR 3.3.6.1.5 SR 3.3.6.1.6 SR 3.3.6.1.7	5 (1.92) psig
b. RCIC Steam Supply Line Pressure - Low	1,2,3	(4.6)	F	SR 3.3.6.1.2 SR 3.3.6.1.3 SR 3.3.6.1.4 SR 3.3.6.1.5 SR 3.3.6.1.6 SR 3.3.6.1.7	5 (20) psig
c. RCIC Turbine Exhaust Discharge Pressure - High	1,2,3	DZ	F	SR 3.3.6.1.1 SR 3.3.6.1.2 SR 3.3.6.1.3 SR 3.3.6.1.4 SR 3.3.6.1.5 SR 3.3.6.1.6 SR 3.3.6.1.7	5 (169)°F
d. Drywell Pressure - High	1,2,3	(1)	F	SR 3.3.6.1.1 SR 3.3.6.1.2 SR 3.3.6.1.3 SR 3.3.6.1.4 SR 3.3.6.1.5 SR 3.3.6.1.6 SR 3.3.6.1.7	5 (1.92) psig
e. RCIC Suppression Pool Ambient Area Temperature - High	1,2,3	(1)	F	SR 3.3.6.1.1 SR 3.3.6.1.2 SR 3.3.6.1.3 SR 3.3.6.1.4 SR 3.3.6.1.5 SR 3.3.6.1.6 SR 3.3.6.1.7	5 (169)°F
f. Suppression Pool Area Temperature - Time Delay Relays	1,2,3	(1)	F	SR 3.3.6.1.1 SR 3.3.6.1.2 SR 3.3.6.1.3 SR 3.3.6.1.4 SR 3.3.6.1.5 SR 3.3.6.1.6 SR 3.3.6.1.7	5 (20) psig
g. RCIC Suppression Pool Area Differential Temperature - High	1,2,3	(1)	F	SR 3.3.6.1.1 SR 3.3.6.1.2 SR 3.3.6.1.3 SR 3.3.6.1.4 SR 3.3.6.1.5 SR 3.3.6.1.6 SR 3.3.6.1.7	5 (42)°F
h. Emergency Area Cooler Temperature - High	1,2,3	(1)	F	SR 3.3.6.1.1 SR 3.3.6.1.2 SR 3.3.6.1.3 SR 3.3.6.1.4 SR 3.3.6.1.5 SR 3.3.6.1.6 SR 3.3.6.1.7	5 (169)°F

(a) Only inputs into one trip system [5]

(continued)

32A-1
4.2A-1
(Doc M.4)

(CTS)

<CTS>

3

Insert Function 4.b

b. RCIC Steam Line
Flow-Timer

1. 2. 3

1

F

SR 3.3.6.1.2
SR 3.3.6.1.4
SR 3.3.6.1.6

2 [3] seconds
and ≤ [9]
seconds

DOC
M.4

6 (ETS)

(T 3.2 A-1)
(F 4.2 A-1)

Primary Containment Isolation Instrumentation
3.3.6.1

Table 3.3.6.1-1 (page 5 of 6)
Primary Containment Isolation Instrumentation

FUNCTION	APPLICABLE NODES OR OTHER SPECIFIED CONDITIONS	REQUIRED CHANNELS PER TRIP SYSTEM	CONDITIONS REFERENCED FROM REQUIRED ACTION C.1	SURVEILLANCE REQUIREMENTS	ALLOWABLE VALUE
4. RCIC System Isolation (continued)					
<p>i. RCIC Turbine Area Temperature - High</p> <p><i>Turbine Area</i></p>	1,2,3	[1]	F	SR 3.3.6.1.1 SR 3.3.6.1.2 SR 3.3.6.1.3 SR 3.3.6.1.4 SR 3.3.6.1.5 SR 3.3.6.1.6 SR 3.3.6.1.7	≤ [170] °F
j. RCIC Equipment Room Differential Temperature - High	1,2,3	[1]	F	SR 3.3.6.1.1 SR 3.3.6.1.2 SR 3.3.6.1.3 SR 3.3.6.1.4 SR 3.3.6.1.7	≤ [] °F
k. Manual Initiation	1,2,3	[1 per group]	G	SR 3.3.6.1.7	NA
5. Reactor Water Cleanup (RWC) System Isolation					
a. Differential Flow - High	1,2,3	[1]	F	SR 3.3.6.1.1 SR 3.3.6.1.2 SR 3.3.6.1.6 SR 3.3.6.1.7 SR 3.3.6.1.8	≤ [79] gpm
b. Area Temperature - High	1,2,3	[3] [1 per room]	F	SR 3.3.6.1.1 SR 3.3.6.1.2 SR 3.3.6.1.3 SR 3.3.6.1.6 SR 3.3.6.1.7 SR 3.3.6.1.8	≤ [150] °F
c. Area Ventilation Differential Temperature - High	1,2,3	[3] [1 per room]	F	SR 3.3.6.1.1 SR 3.3.6.1.2 SR 3.3.6.1.3 SR 3.3.6.1.6 SR 3.3.6.1.7 SR 3.3.6.1.8	≤ [67] °F
d. SLC System Initiation	1,2	[1]	F	SR 3.3.6.1.1	NA
e. Reactor Vessel Meter Level - Low	1,2,3	[2]	F	SR 3.3.6.1.1 SR 3.3.6.1.2 SR 3.3.6.1.3 SR 3.3.6.1.6 SR 3.3.6.1.7	≥ [144] inches
f. Manual Initiation	1,2,3	[1 per group]	G	SR 3.3.6.1.7	NA

(b) SLC System Initiation only inputs into one of the two trip systems. [5]

(continued)

6 (CTS)

Primary Containment Isolation Instrumentation 3.3.6.1

3.2.A1
3.4.2.A1

Table 3.3.6.1-1 (page 6 of 6)
Primary Containment Isolation Instrumentation

FUNCTION	APPLICABLE MODES OR OTHER SPECIFIED CONDITIONS	REQUIRED CHANNELS PER TRIP SYSTEM	CONDITIONS REFERENCED FROM REQUIRED ACTION C.1	SURVEILLANCE REQUIREMENTS	ALLOWABLE VALUE
6. Shutdown Cooling System Isolation a. Reactor Vessel Pressure - High <i>(Vessel)</i>	1,2,3	2	5	SR 3.3.6.1.1 SR 3.3.6.1.2 SR 3.3.6.1.3 SR 3.3.6.1.4 SR 3.3.6.1.5 [≤ 135 psig]	135
b. Reactor Vessel Water Level - Low <i>(Level 3)</i>	3,4,5	1, 3	5	SR 3.3.6.1.1 [≥ 144 inches] SR 3.3.6.1.2 SR 3.3.6.1.3 SR 3.3.6.1.4 SR 3.3.6.1.5	144

Only one trip system required in MODES 4 and 5 when RHR Shutdown Cooling System integrity maintained.

In MODES 4 and 5, provided RHR Shutdown Cooling System integrity is maintained, only one channel per trip system with an isolation signal available to one shutdown cooling pump suction isolation valve is required.

JUSTIFICATION FOR DEVIATIONS FROM NUREG-1433, REVISION 1
ITS: 3.3.6.1 - PRIMARY CONTAINMENT ISOLATION INSTRUMENTATION

1. The proper Primary Containment Isolation Functions that are common to the RPS Instrumentation have been provided.
2. The Completion Time of ISTS 3.3.6.1 Required Action E.1 has been extended by 2 hours consistent with the current licensing basis.
3. Three new Primary Containment Isolation Functions have been added (ITS Table 3.3.6.1-1 Functions 1.c, 3.b and 4.b), consistent with current Quad Cities 1 and 2 Licensing Basis. In addition, 25 Functions have been deleted (ISTS Table 3.3.6.1-1 Functions 1.d, 1.f, 1.g, 1.h, 2.d, 2.e, 2.f, 3.c, 3.f, 3.g, 3.h, 3.i, 3.j, 4.c, 4.d, 4.e, 4.f, 4.g, 4.h, 4.j, 4.k, 5.a, 5.b, 5.c and 5.f) since they are not applicable to Quad Cities 1 and 2. The Functions, ACTIONS, and Surveillance Requirements have been revised where applicable, to reflect these additions and deletions.
4. Editorial change made to be consistent with other similar requirements in the ITS or for clarity.
5. The brackets have been removed and the proper plant specific information/value has been provided. Table footnotes have been renumbered, as required.
6. ISTS SR 3.3.6.1.8, the Isolation System Response Time test, is not included in the Quad Cities ITS. This allowance is consistent with the current licensing basis reflected in the CTS. In addition, the Reviewer's Note has been deleted. The Note is not meant to be retained in the final version of the plant specific submittal.
7. The proper Quad Cities 1 and 2 plant specific nomenclature/value/design requirements have been provided.
8. The bracketed Surveillances have been deleted since they do not apply to the associated Function. These changes are consistent with the current licensing basis.
9. These Surveillances have been deleted since they can not be performed on the associated Function.
10. This additional Surveillance, requiring performance of a CHANNEL CALIBRATION once per 92 days, has been added consistent with the current setpoint calibration methodology (SR 3.3.6.1.4). As a result, ISTS SR 3.3.6.1.6 is deleted from the Table 3.3.6.1-1 Surveillance Requirement column, for the applicable Functions, for the same reason.
11. The Surveillances associated with ITS 3.3.6.1-1 Function 1.d (Main Steam Tunnel Temperature—High) and Function 3.e (HPCI Turbine Area Temperature—High) have been revised to reflect current licensing requirements, therefore, SR 3.3.6.1.2 has been removed from the Table for these Functions.

JUSTIFICATION FOR DEVIATIONS FROM NUREG-1433, REVISION 1
ITS: 3.3.6.1 - PRIMARY CONTAINMENT ISOLATION INSTRUMENTATION

12. ISTS Table 3.3.6.1-1 footnote c (ITS footnote b) has been revised to reflect the plant specific design of the RHR Shutdown Cooling System suction isolation valve isolation logic.

{CTS}

Secondary Containment Isolation Instrumentation
3.3.6.2

3.3 INSTRUMENTATION

3.3.6.2 Secondary Containment Isolation Instrumentation

{3.2.A} LCO 3.3.6.2 The secondary containment isolation instrumentation for each Function in Table 3.3.6.2-1 shall be OPERABLE.

{Appl 3.2.A} APPLICABILITY: According to Table 3.3.6.2-1.

ACTIONS

NOTE

{DOCA.2} Separate Condition entry is allowed for each channel.

CONDITION	REQUIRED ACTION	COMPLETION TIME
A. One or more channels inoperable.	A.1 Place channel in trip.	12 hours for Function ₂ AND 24 hours for Functions other than Function ₂
B. One or more automatic Functions with secondary containment isolation capability not maintained.	B.1 Restore secondary containment isolation capability.	1 hour
C. Required Action and associated Completion Time of Condition A or B not met.	C.1.1 Isolate the associated zone(s) . OR penetration flow path	1 hour (continued)

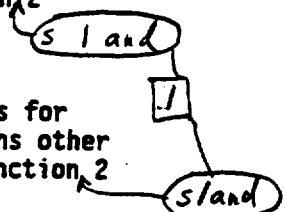

2

3

4

{3.2.A Act 1}

{3.2.A Act 2}

{3.2.A Act 1}

{3.2.A Act 2}

{3.2.A Act 2}

{3.2.A Footnote 2}

3

3

(CTS)

Secondary Containment Isolation Instrumentation
3.3.6.2

ACTIONS

C. (continued)
{ 3.2.A Act 2 }
{ 3.2.A footnote a }

CONDITION	REQUIRED ACTION	COMPLETION TIME
	C.1.2 Declare associated secondary containment isolation valves inoperable.	1 hour
	AND	
	C.2.1 Place the associated standby gas treatment (SGT) subsystem (S) in operation.	1 hour
	OR	
	C.2.2 Declare associated SGT subsystem (S) inoperable.	1 hour

SURVEILLANCE REQUIREMENTS

{ 4.2.A.1 }
{ 3.2.A1 footnote a }
[3]

NOTES

1. Refer to Table 3.3.6.2-1 to determine which SRs apply for each Secondary Containment Isolation Function.
2. When a channel is placed in an inoperable status solely for performance of required Surveillances, entry into associated Conditions and Required Actions may be delayed for up to 6 hours provided the associated Function maintains ~~Secondary containment~~ isolation capability.

SURVEILLANCE	FREQUENCY
SR 3.3.6.2.1 Perform CHANNEL CHECK.	12 hours

(continued)

{CTS}

Secondary Containment Isolation Instrumentation
3.3.6.2

SURVEILLANCE REQUIREMENTS (continued)

SURVEILLANCE	FREQUENCY
<p>{T 4.2.A-1} SR 3.3.6.2.2 Perform CHANNEL FUNCTIONAL TEST.</p>	<p>X92 days 4</p>
<p>{T 4.2.A-1} SR 3.3.6.2.3 Calibrate the trip unit. {T 4.2.A-1 footnote a}</p>	<p>X92 days * 4</p>
<p>{T 4.2.A-1} SR 3.3.6.2.4 Perform CHANNEL CALIBRATION.</p>	<p>92 days * 4</p>
<p>{T 4.2.A-1} SR 3.3.6.2.5 Perform CHANNEL CALIBRATION. {T 4.2.A-1 footnote a}</p>	<p>X18 months 24 4</p>
<p>{4.2.A.6} SR 3.3.6.2.6 Perform LOGIC SYSTEM FUNCTIONAL TEST. {4.7.P.4}</p>	<p>X18 months 24 4</p>
<p>SR 3.3.6.2.7 NOTE Radiation detectors may be excluded. Verify the ISOLATION SYSTEM RESPONSE TIME is within limits. Reviewer's Note: This SR is applied only to Functions of Table 3.3.6.2-1 with required response times not corresponding to DG start time.</p>	

<CTS>

<T 3.2.A-1>

<T 4.2.A-1>

Secondary Containment Isolation Instrumentation 3.3.6.2

Table 3.3.6.2-1 (page 1 of 1)
Secondary Containment Isolation Instrumentation

FUNCTION	APPLICABLE MODES OR OTHER SPECIFIED CONDITIONS	REQUIRED CHANNELS PER TRIP SYSTEM	SURVEILLANCE REQUIREMENTS	ALLOWABLE VALUE
1. Reactor Vessel Water Level - Low <u>Low, Level/2</u>	1,2,3, X(a)X	XZX 4	SR 3.3.6.2.1 SR 3.3.6.2.2 XSR 3.3.6.2.3X SR 3.3.6.2.5 SR 3.3.6.2.6 SR 3.3.6.2.7	[≥ X-4.7K inches] 144 4
2. Drywell Pressure - High	1,2,3	XZX SR 3.3.6.2.4 6	SR 3.3.6.2.1 SR 3.3.6.2.2 SR 3.3.6.2.3 SR 3.3.6.2.5 SR 3.3.6.2.6 SR 3.3.6.2.7	[≤ X1.92K psig] 2.5 4
3. Reactor Building Exhaust Radiation - High	1,2,3, X(a),(b)X	XZX SR 3.3.6.2.4 6	SR 3.3.6.2.1 SR 3.3.6.2.2 SR 3.3.6.2.3 SR 3.3.6.2.6 SR 3.3.6.2.7	[≤ X100 mR/hr] 10 4
4. Refueling Floor <u>Exhaust</u> Radiation - High	1,2,3, X(a),(b)X	XZX 4	SR 3.3.6.2.1 SR 3.3.6.2.2 XSR 3.3.6.2.4 SR 3.3.6.2.6 SR 3.3.6.2.7	[≤ X200 mR/hr] 100 4
5. Manual Initiation	1,2,3, [(a),(b)]	[1 per group]	SR 3.3.6.2.6	NA

- (a) During operations with a potential for draining the reactor vessel.
- (b) During CORE ALTERATIONS and during movement of irradiated fuel assemblies in secondary containment.

4

4

JUSTIFICATION FOR DEVIATIONS FROM NUREG-1433, REVISION 1
ITS: 3.3.6.2 - SECONDARY CONTAINMENT ISOLATION INSTRUMENTATION

1. Changes have been made (additions, deletions, and/or changes to the NUREG) to reflect the plant specific nomenclature, number, reference, system description, analysis description, or licensing basis description.
2. As stated in the Bases for the Manual Initiation Function, it is not assumed in any safety analysis in the UFSAR. Since the NRC did not require it to be included in the CTS of Quad Cities 1 and 2, it is not required by the NRC approved licensing basis to be included in the ITS. In addition, due to the deletion of the Manual Initiation Function from ITS Table 3.3.6.2-1, the term "automatic" in ITS 3.3.6.2 Condition B is not needed and has been deleted.
3. Editorial change made to be consistent with other similar requirements in the ITS or for clarity.
4. The brackets have been removed and the proper plant specific information/value has been provided.
5. The Reviewer's Note states that ISTS SR 3.3.6.2.7 only applies to Functions with required response times not corresponding to the DG start time. For the Secondary Containment Isolation Instrumentation Functions, there are no appropriate Functions. Therefore, the entire ISTS SR 3.3.6.2.7 has been deleted. This change is also consistent with the current licensing basis reflected in Technical Specifications.
6. These Surveillances have been revised for the Table 3.3.6.2-1 Functions consistent with the current licensing basis requirements.

↳ (CTS)

(LLS) Instrumentation
3.3.6.3

3.3 INSTRUMENTATION

Relief Valve

3.3.6.3 (Low-Low Set (LLS)) Instrumentation

(3.6.F)

LCO 3.3.6.3 The (LLS) valve instrumentation for each Function in Table 3.3.6.3-1 shall be OPERABLE.

relief

(Appl 3.6.F)

APPLICABILITY: MODES 1, 2, and 3.

ACTIONS

(3.6.F Act 2)

CONDITION	REQUIRED ACTION	COMPLETION TIME
<p>(relief)</p> <p>A. One (LLS) valve inoperable due to inoperable channel(s).</p>	<p>A.1 Restore channel(s) to OPERABLE status.</p>	<p>(24 hours) 14 days</p>
<p>B. One or more safety/relief valves (S/RVs) with one Function 3 channel inoperable.</p>	<p>B.1</p> <p>NOTE LCO 3.0.4 is not applicable.</p> <p>Restore tailpipe pressure switches to OPERABLE status.</p>	<p>Prior to entering MODE 2 or 3 from MODE 4</p>
<p>C. NOTE Separate Condition entry is allowed for each S/RV.</p> <p>One or more S/RVs with two Function 3 channels inoperable.</p>	<p>C.1 Restore one tailpipe pressure switch to OPERABLE status.</p>	<p>[14] days</p>

(continued)

6 (CTS)

Relief Valve

LLS Instrumentation
3.3.6.3

1

ACTIONS (continued)

(3.6.F Act 2)
(3.6.F Act 3)

CONDITION	REQUIRED ACTION	COMPLETION TIME
(B) (D) Required Action and associated Completion Time of Condition A, B, or C not met. OR relief Two or more LLS valves inoperable due to inoperable channels.	(B) D.1 Declare the associated LLS valve(s) inoperable.	Immediately
	AND B.2 Be in MODE 4.	12 hours 36 hours

1

SURVEILLANCE REQUIREMENTS

(Doc A.2)

NOTE 1

1. Refer to Table 3.3.6.3-1 to determine which SRs apply for each Function.
2. When a channel is placed in an inoperable status solely for performance of required Surveillances, entry into associated Conditions and Required Actions may be delayed for up to 6 hours provided the associated Function maintains LLS initiation capability.

1

SURVEILLANCE		FREQUENCY
SR 3.3.6.3.1	Perform CHANNEL CHECK.	12 hours
SR 3.3.6.3.2	Perform CHANNEL FUNCTIONAL TEST for portion of the channel outside primary containment.	[92] days

1

1

(continued)

<CTS>

Relief Valve

1

Instrumentation
3.3.6.3

SURVEILLANCE REQUIREMENTS (continued)

SURVEILLANCE	FREQUENCY
<p>SR 3.3.6.3.3</p> <p style="text-align: center;">NOTE</p> <p>Only required to be performed prior to entering MODE 2 during each scheduled outage > 72 hours when entry is made into primary containment.</p> <p>Perform CHANNEL FUNCTIONAL TEST for portions of the channel inside primary containment.</p>	<p>[92] days</p>
<p>SR 3.3.6.3.4 Perform CHANNEL FUNCTIONAL TEST.</p>	<p>[92] days</p>
<p>SR 3.3.6.3.5 Calibrate the trip unit.</p>	<p>[92] days</p>
<p><4.6.F.1.b> SR 3.3.6.3.6 Perform CHANNEL CALIBRATION.</p>	<p>(18) months</p>
<p><4.6.F.1.b> SR 3.3.6.3.7 Perform LOGIC SYSTEM FUNCTIONAL TEST.</p>	<p>(18) months</p>

All changes [1] unless noted otherwise

Relief Valve

K/S Instrumentation
3.3.6.3

<CTS>
<3.6.F>
<4.6.F.1>
<DDC M.1>

Relief Valve

Table 3.3.6.3-1 (page 1 of 1)
Low-Low Set Instrumentation

FUNCTION	REQUIRED CHANNELS PER FUNCTION	SURVEILLANCE REQUIREMENTS	ALLOWABLE VALUE
1. Reactor Steam Dome Pressure - High	[1 per LLS valve]	SR 3.3.6.3.1 SR 3.3.6.3.4 SR 3.3.6.3.5 SR 3.3.6.3.6 SR 3.3.6.3.7	≤ [1054] psig
2. Low-Low Set Pressure Setpoints	[2 per LLS valve]	SR 3.3.6.3.1 SR 3.3.6.3.4 SR 3.3.6.3.5 SR 3.3.6.3.6 SR 3.3.6.3.7	Low: Open ≤ [1090] psig Close ≤ [840] psig Medium-Low: Open ≤ [1025] psig Close ≤ [875] psig Medium-High: Open ≤ [1040] psig Close ≤ [890] psig High: Open ≤ [1050] psig Close ≤ [900] psig
3. Tailpipe Pressure Switch	[22] [2 per S/R]	SR 3.3.6.3.1 SR 3.3.6.3.2 SR 3.3.6.3.3 SR 3.3.6.3.6 SR 3.3.6.3.7	≥ [80] psig and ≤ [100] psig

1. Low Set Relief Valves			
a. Reactor Vessel Pressure Setpoint	1 per valve	SR 3.3.6.3.1 SR 3.3.6.3.2	≤ [1115] psig
b. Reactivation Time Delay	2 per valve	SR 3.3.6.3.1 SR 3.3.6.3.2	≥ [10] seconds and ≤ [16.5] seconds
2. Relief Valves			
a. Reactor Vessel Pressure Setpoint	1 per valve	SR 3.3.6.3.1 SR 3.3.6.3.2	≤ [1035] psig

JUSTIFICATION FOR DEVIATIONS FROM NUREG-1433, REVISION 1
ITS: 3.3.6.3 - RELIEF VALVE INSTRUMENTATION

1. Changes have been made (additions, deletions, and/or changes to the NUREG) to reflect the plant specific nomenclature, number, reference, system description, analysis description, or licensing basis description.
2. The brackets have been removed and the proper plant specific value/nomenclature has been provided.

{CTS}

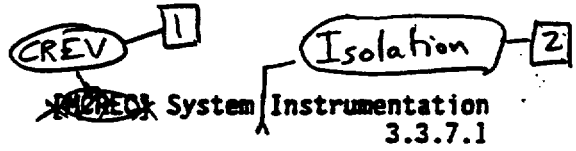

3.3 INSTRUMENTATION

3.3.7.1 ~~MAIN~~ Control Room ~~Environmental Control~~ (CREV) System Instrumentation

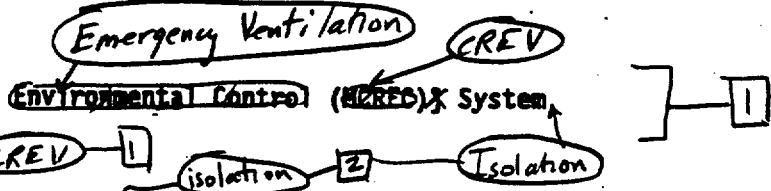

{3.2.A}

LCO 3.3.7.1 The ~~CREV~~ System instrumentation for each Function in Table 3.3.7.1-1 shall be OPERABLE.

{App
3.2.A}

APPLICABILITY: According to Table 3.3.7.1-1.

ACTIONS

{DOC A.3}

NOTE
Separate Condition entry is allowed for each channel.

CONDITION	REQUIRED ACTION	COMPLETION TIME
A. One or more required channels inoperable.	A.1 Enter the Condition referenced in Table 3.3.7.1-1 for the channel.	Immediately
B. As required by Required Action A.1 and referenced in Table 3.3.7.1-1.	B.1 Declare associated CREV subsystem inoperable. AND B.2 Place channel in trip.	1 hour from discovery of loss of CREV instrumentation capability in both trip systems 24 hours

{3.2.A
Action 1}
{3.2.A
Action 2}

{3.2.A
ACT 2}

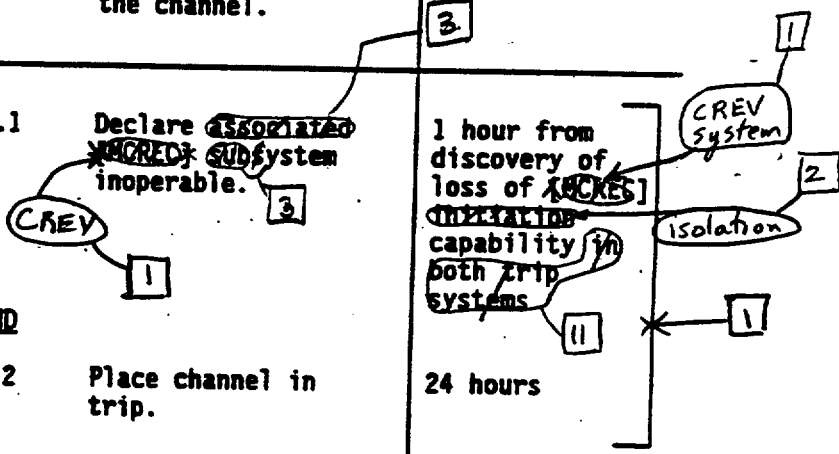

(continued)

6 (CTS)

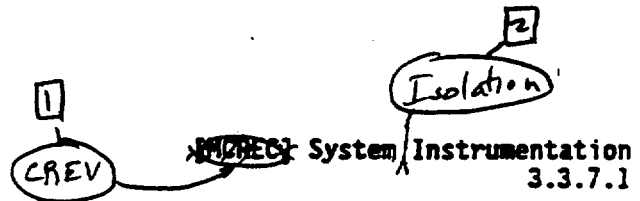

ACTIONS (continued)

CONDITION	REQUIRED ACTION	COMPLETION TIME	
<p>C. As required by Required Action A.1 and referenced in Table 3.3.7.1-1.</p>	<p>C.1 Declare associated MCREC subsystem inoperable.</p> <p><i>(CREV) 1</i> <i>isolation 2</i> <i>3</i></p>	<p>1 hour from discovery of loss of MCREC INITIATION capability in both trip systems</p> <p><i>CREV System</i> 1</p>	
	<p>AND</p> <p>C.2 Place channel in trip.</p>		<p>6 hours</p> <p><i>12</i> <i>4</i></p>
<p>D. Required Action and associated Completion Time of Condition B or C not met.</p> <p><i>Isolate each required control room penetration flow path.</i> 2</p>	<p>D.1</p> <p>NOTE Place in toxic gas protection mode if automatic transfer to toxic gas protection mode is inoperable.</p> <p>Place the associated MCREC subsystem(s) in the [pressurization] mode of operation.</p>	<p>1 hour</p> <p>5</p>	
	<p>OR</p> <p>D.2</p> <p>NOTE Only applicable to Function 3 channels.</p>		<p>1 hour</p>
	<p>OR</p> <p>Isolate associated main steam line (MSL).</p>		

{ 3.2.A Act 2 }

{ 3.2.A Act 2 }
{ 3.2.A footnote a }

{ 3.2.A-1 ACTION 21 }

{ 3.2.A-1 ACTION 24 }

6 (CTS)

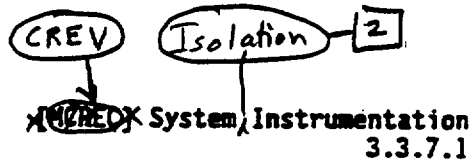

ACTIONS

CONDITION	REQUIRED ACTION	COMPLETION TIME
D. (continued)	D.3 Declare ASSOCIATED INOPERABLE SYSTEM inoperable.	1 hour

{3.2.A Act 2}
{3.2.A footnote a}

CREV 1

SURVEILLANCE REQUIREMENTS

NOTES

1. Refer to Table 3.3.7.1-1 to determine which SRs apply for each ~~INOPERABLE~~ Function.
2. When a channel is placed in an inoperable status solely for performance of required Surveillances, entry into associated Conditions and Required Actions may be delayed for up to 6 hours provided the associated Function maintains ~~INOPERABLE~~ ~~INTEGRATION~~ capability.

CREV System Isolation 1

{4.2.A.1}

{T3.2.A-1 footnote a} 1

CREV System

Isolation 3

SURVEILLANCE	FREQUENCY
SR 3.3.7.1.1 Perform CHANNEL CHECK.	12 hours
SR 3.3.7.1.2 Perform CHANNEL FUNCTIONAL TEST.	92 days 1
SR 3.3.7.1.3 Calibrate the trip units.	92 days
SR 3.3.7.1.5 Perform CHANNEL CALIBRATION.	12 months 24 1
SR 3.3.7.1.6 Perform LOGIC SYSTEM FUNCTIONAL TEST.	12 months 24 1
SR 3.3.7.1.4 Perform CHANNEL CALIBRATION.	92 days

{T 3.2.A-1}

{T 3.2.A-1}

{T 3.2.A-1} {T.3.2.A-1 footnote a}

{T 3.2.A-1}

{4.2.A.2}

(CTS)

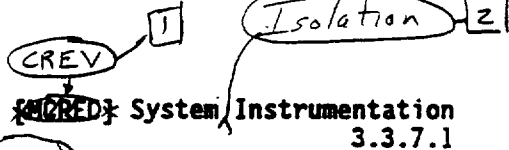

{T 3.2.A1}
{T 4.2.A2}

Table 3.3.7.1-1 (page 1 of 1)
Main Control Room Environmental Control System Instrumentation
Emergency Ventilation

FUNCTION	APPLICABLE NODES OR OTHER SPECIFIED CONDITIONS	REQUIRED CHANNELS PER TRIP SYSTEM	CONDITIONS REFERENCED FROM REQUIRED ACTION A.1	SURVEILLANCE REQUIREMENTS	ALLOWABLE VALUE
1. Reactor Vessel Water Level - Low Level 1 Level 2 Level 3 Level 4 Level 5 Level 6 Level 7	1,2,3,4,5,6,7	X2X	C	SR 3.3.7.1.1 SR 3.3.7.1.2 SR 3.3.7.1.3 SR 3.3.7.1.4 SR 3.3.7.1.5	≥ 12 inches
2. Drywell Pressure - High	1,2,3	X2X	C	SR 3.3.7.1.1 SR 3.3.7.1.2 SR 3.3.7.1.3 SR 3.3.7.1.4 SR 3.3.7.1.5	≤ 192 psig
3. Main Steam Line Flow - High	1,2,3	X2 per MSLX	B	SR 3.3.7.1.1 SR 3.3.7.1.2 SR 3.3.7.1.3 SR 3.3.7.1.4 SR 3.3.7.1.5	≥ 100% rated steam flow
4. Refueling Floor Radiation - High	1,2,3, X(a), (b)	X2X	C	SR 3.3.7.1.1 SR 3.3.7.1.2 SR 3.3.7.1.4 SR 3.3.7.1.5	≤ 100 mR/hr
5. Control Room Air Inlet Radiation - High	1,2,3, (a), (b)	[1]	C	SR 3.3.7.1.1 SR 3.3.7.1.2 SR 3.3.7.1.4 SR 3.3.7.1.5	≤ 10 mR/hr

- (a) During operations with a potential for draining the reactor vessel.
- (b) During ~~SCORE ALTERATIONS~~ and during movement of irradiated fuel assemblies in the ~~(secondary)~~ containment.

5. Reactor Building Ventilation Exhaust Radiation - High	1,2,3 (a)(b)	2	B	SR 3.3.7.1.1 SR 3.3.7.1.2 SR 3.3.7.1.4 SR 3.3.7.1.6	≤ 10 mR/hr
--	--------------	---	---	--	------------

JUSTIFICATION FOR DEVIATIONS FROM NUREG-1433, REVISION 1
ITS: 3.3.7.1 - CREV SYSTEM INSTRUMENTATION

1. The brackets have been removed and the proper plant specific information/value has been provided.
2. The CREV System does not automatically actuate upon receipt of an automatic actuation signal, however the control room penetration flow path dampers do receive an automatic isolation signal. Therefore, the Specification has been modified to reflect this design difference.
3. The CREV System only includes one subsystem. Therefore, reference to the associated "subsystem" has been deleted and replaced with "System."
4. ISTS 3.3.7.1 Required Action C.2 Completion Time has been extended from 6 hours to 12 hours to provide the proper requirements for the Reactor Water Level and Drywell Pressure Functions. This time is consistent with NEDC-30851P-A, Supplement 2. In addition, the proper condition has been referenced in the Table.
5. The Quad Cities 1 and 2 design of the CREV System does not include a distinct toxic gas mode; therefore, this Note has been deleted.
6. A Surveillance Requirement (SR 3.3.7.1.4), which requires a CHANNEL CALIBRATION every 92 days for the Drywell Pressure—High, the Reactor Building Ventilation Exhaust — High, and the Refueling Floor Radiation — High Functions, has been added, consistent with the current Licensing Basis. Subsequent SRs have been renumbered to reflect this change.
7. The proper plant specific nomenclature has been provided.
8. The CHANNEL CHECK Surveillance Requirement for the Drywell Pressure—High Function has not been added into the ITS since the Quad Cities 1 and 2 design does not include indication to perform a CHANNEL CHECK. This is also consistent with current Licensing Basis.
9. The bracketed Surveillance has been removed from Table 3.3.7.1-1 since it does not apply to these Functions.
10. One Function has been added (ITS Table 3.3.7.1-1 Function 5, Reactor Building Ventilation Exhaust Radiation—High) and one Function has been deleted (ISTS Table 3.3.7.1-1 Function 5, Control Room Air Inlet Radiation—High) consistent with the current licensing and design basis.

JUSTIFICATION FOR DEVIATIONS FROM NUREG-1433, REVISION 1
ITS: 3.3.7.1 - CREV SYSTEM INSTRUMENTATION

11. ACTION B requires entry for the Main Steam Line Flow—High, Refueling Floor Radiation—High and Reactor Building Ventilation Exhaust Radiation — High Functions. The logic for the Main Steam Line Flow—High Function requires both trip systems to trip for isolation to occur while the Refueling Floor Radiation—High and Reactor Building Ventilation Exhaust Radiation — High Functions only require one trip system to trip. Therefore, for clarity, the wording "in both trip systems" has been deleted since it only applies to the Main Steam Line Flow—High Function. The Bases adequately describes when entry is required.

<CTS>

1

Insert ITS 3.3.7.2 (Page 1 of 3)

Mechanical Vacuum Pump Trip Instrumentation
3.3.7.2

3.3 INSTRUMENTATION

3.3.7.2 Mechanical Vacuum Pump Trip Instrumentation

<3.2.L>

LCO 3.3.7.2 Four channels of Main Steam Line Radiation-High Function for the mechanical vacuum pump trip shall be OPERABLE.

<App 3.2.L>

APPLICABILITY: MODES 1 and 2 with the mechanical vacuum pump in service and any main steam line not isolated.

ACTIONS

<DOC A.3>

-----NOTE-----
Separate Condition entry is allowed for each channel.

CONDITION	REQUIRED ACTION	COMPLETION TIME
A. One or more channels inoperable.	A.1 Restore channel to OPERABLE status.	12 hours
	<u>OR</u> A.2 -----NOTE----- Not applicable if inoperable channel is the result of an inoperable mechanical vacuum pump breaker. ----- Place channel in trip.	12 hours
B. Mechanical vacuum pump trip capability not maintained.	B.1 Restore trip capability.	1 hour

<3.2.L Action>

<3.2.L Action>

(continued)

<CTS>

1

ACTIONS

CONDITION	REQUIRED ACTION	COMPLETION TIME
C. Required Action and associated Completion Time not met.	C.1 Isolate the associated mechanical vacuum pump.	12 hours
	<u>OR</u>	
	C.2 Remove the associated mechanical vacuum pump breaker(s) from service.	12 hours
	<u>OR</u>	
	C.3 Isolate the main steam lines.	12 hours
	<u>OR</u>	
	C.4 Be in MODE 3.	12 hours

{3.2.L Action}

<CTS>

1

SURVEILLANCE REQUIREMENTS

-----NOTE-----
 When a channel is placed in an inoperable status solely for performance of required Surveillances, entry into associated Conditions and Required Actions may be delayed for up to 6 hours provided mechanical vacuum pump trip capability is maintained.

<3.2.1 footnote c>

SURVEILLANCE	FREQUENCY
<4.2.L.1> SR 3.3.7.2.1 Perform CHANNEL CHECK.	12 hours
<4.2.L.2> SR 3.3.7.2.2 Perform CHANNEL FUNCTIONAL TEST.	92 days
<4.2.L.3> <4.2.L.3 footnote a> SR 3.3.7.2.3 -----NOTE----- Radiation detectors are excluded. ----- Perform CHANNEL CALIBRATION.	92 days
<4.2.L.3> SR 3.3.7.2.4 Perform CHANNEL CALIBRATION. The Allowable Value shall be [$\leq 15 \times$ full power background without hydrogen injection].	24 months
<4.2.L.4> SR 3.3.7.2.5 Perform LOGIC SYSTEM FUNCTIONAL TEST including mechanical vacuum pump breaker actuation.	24 months

JUSTIFICATION FOR DEVIATIONS FROM NUREG-1433, REVISION 1
ITS 3.3.7.2: MECHANICAL VACUUM PUMP TRIP INSTRUMENTATION

1. A new Specification (ITS 3.3.7.2, "Mechanical Vacuum Pump Trip Instrumentation") has been added consistent with the current licensing basis.

{CTS}

3.3 INSTRUMENTATION

3.3.8.1 Loss of Power (LOP) Instrumentation

{3.2.B}

LCO 3.3.8.1 The LOP instrumentation for each Function in Table 3.3.8.1-1 shall be OPERABLE.

{Appl 3.2.B}

APPLICABILITY:

MODES 1, 2, and 3,
When the associated diesel generator is required to be OPERABLE by LCO 3.8.2, "AC Sources—Shutdown."

{T 3.2.B-1
Footnote c}

{T 4.2.B-1
Footnote c}

ACTIONS

{DOC A.4}

NOTE

Separate Condition entry is allowed for each channel.

{3.2.B Act 1}

{3.2.B Act 2}

{T 3.2.B-1
ACTION 36}

CONDITION	REQUIRED ACTION	COMPLETION TIME
A. One or more channels inoperable.	A.1 Place channel in trip.	1 hour
B. Required Action and associated Completion Time not met.	B.1 Declare associated diesel generator (DG) inoperable.	Immediately

{T 3.2.B-1
ACTION 36}

<CTS>

SURVEILLANCE REQUIREMENTS

NOTES

- 1. Refer to Table 3.3.8.1-1 to determine which SRs apply for each LOP Function.
- 2. When a channel is placed in an inoperable status solely for performance of required Surveillances, entry into associated Conditions and Required Actions may be delayed for up to 2 hours provided the associated Function maintains ~~DC~~ initiation capability.

LOP

1

SURVEILLANCE	FREQUENCY
SR 3.3.8.1.1 Perform CHANNEL CHECK.	12 hours
SR 3.3.8.1.2 Perform CHANNEL FUNCTIONAL TEST.	31 days
SR 3.3.8.1.3 Perform CHANNEL CALIBRATION.	18 months
SR 3.3.8.1.4 Perform LOGIC SYSTEM FUNCTIONAL TEST.	18 months

(T 4.2.B.1)

(T 4.2.B.1)

(4.2.B.2)

1

2

3

2

3

2

CT5

3.2.B-1 Functional Unit 6
4.2.B-1 Functional Unit 6

DOC M2

4160V Essential Service System

Table 3.3.8.1-1 (page 1 of 1)
Loss of Power Instrumentation

LOP Instrumentation
3.3.8.1

FUNCTION	REQUIRED CHANNELS PER BUS	SURVEILLANCE REQUIREMENTS	ALLOWABLE VALUE
1. 4160V Emergency Bus Undervoltage (Loss of Voltage)	2	SR 3.3.8.1.1 SR 3.3.8.1.2 SR 3.3.8.1.3 SR 3.3.8.1.4	≥ 2893 V and ≤ 3197 V
a. Bus Undervoltage	2		
b. Time Delay	2	SR 3.3.8.1.2 SR 3.3.8.1.3 SR 3.3.8.1.4	≥ 1 seconds and ≤ 6.5 seconds
2. 4160V Emergency Bus Undervoltage (Degraded Voltage)	2	SR 3.3.8.1.1 SR 3.3.8.1.2 SR 3.3.8.1.3 SR 3.3.8.1.4	≥ 3845 V and ≤ 3933 V
a. Bus Undervoltage	2		
b. Time Delay	2		≥ 285 seconds and ≤ 315 seconds
			with time delay ≥ 5.6 seconds and ≤ 8.4 seconds

JUSTIFICATION FOR DEVIATIONS FROM NUREG-1433, REVISION 1
ITS: 3.3.8.1 - LOP INSTRUMENTATION

1. The proper Quad Cities 1 and 2 plant specific nomenclature/value/design requirements have been provided.
2. The brackets have been removed and the proper plant specific information/value has been provided or the requirement has been deleted. The following requirements have been renumbered to reflect the deletion, as applicable.
3. The ISTS SR 3.3.8.1.2 CHANNEL FUNCTIONAL TEST Frequency has been changed from 31 days to 24 months consistent with the current refueling cycle intervals and the 24 month Surveillance interval extension justifications.
4. ISTS Table 3.3.8.1-1, Function 1.b, 4.16 kV Emergency Bus Undervoltage (Loss of Voltage) Time Delay, has been deleted. The Quad Cities 1 and 2 instrumentation design does not include a time delay associated with the loss of voltage function, except as provided by the bus undervoltage relay inverse time/voltage characteristics. The previous Function has been renumbered as required.
5. ISTS Table 3.3.8.1-1, Function 2.a, 4.16 kV Emergency Bus Undervoltage (Degraded Voltage), has been revised to include the inherent (adjustable) time delay associated with the degraded voltage relays.

(CTS)

RPS Electric Power Monitoring
3.3.8.2

3.3 INSTRUMENTATION

3.3.8.2 Reactor Protection System (RPS) Electric Power Monitoring

3.9.6 LCO 3.3.8.2 Two RPS electric power monitoring assemblies shall be OPERABLE for each inservice RPS motor generator set or alternate power supply.

{App
3.9.6}

APPLICABILITY: MODES 1, 2, and 3, MODES 4 and 5 with any control rod withdrawn from a core cell containing one or more fuel assemblies.

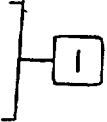

ACTIONS

CONDITION	REQUIRED ACTION	COMPLETION TIME
{3.9.6 Act 1} A. One or both inservice power supplies with one electric power monitoring assembly inoperable.	A.1 Remove associated inservice power supply(s) from service.	72 hours
{3.9.6 Act 2} B. One or both inservice power supplies with both electric power monitoring assemblies inoperable.	B.1 Remove associated inservice power supply(s) from service.	1 hour
{DOC A.3} C. Required Action and associated Completion Time of Condition A or B not met in MODE 1, 2, (07) 3.	C.1 Be in MODE 3.	12 hours
	C.2 Be in MODE 4.	36 hours

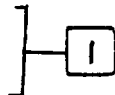

(continued)

E {CTS}

ACTIONS (continued)

CONDITION	REQUIRED ACTION	COMPLETION TIME
<p>(DOC L.4) D. Required Action and associated Completion Time of Condition A or B not met in MODE 4 or 5 with any control rod withdrawn from a core cell containing one or more fuel assemblies.</p> <p>1</p>	D.1 Initiate action to fully insert all insertable control rods in core cells containing one or more fuel assemblies.	Immediately
	<p>AND</p> <p>D.2.1 Initiate action to restore one electric power monitoring assembly to OPERABLE status for inservice power supply(s) supplying required instrumentation.</p>	Immediately
	<p>OR</p> <p>D.2.2 Initiate action to isolate the Residual Heat Removal Shutdown Cooling System.</p>	Immediately

2

SURVEILLANCE REQUIREMENTS

SURVEILLANCE	FREQUENCY
<p>(4.9.6.1) SR 3.3.8.2.1</p> <p>NOTE Only required to be performed prior to entering MODE 2 (or 3) from MODE 4, when in MODE 4 for ≥ 24 hours. (3 or)</p> <p>Perform CHANNEL FUNCTIONAL TEST.</p>	184 days

1

(continued)

<CTS>

RPS Electric Power Monitoring
3.3.8.2

SURVEILLANCE REQUIREMENTS (continued)

SURVEILLANCE	FREQUENCY
<p>(4.9.G.2) SR 3.3.8.2.2 Perform CHANNEL CALIBRATION. The Allowable Values shall be:</p> <p>a. Overvoltage [\leq <u>[132]</u> V.] <i>with time delay set to \leq [4] seconds</i></p> <p>b. Undervoltage [\geq <u>[108]</u> V.] with time delay set to <u>[zero]</u>.</p> <p>c. Underfrequency [\geq <u>[57]</u> Hz] with time delay set to <u>[zero]</u>.</p> <p><i>Handwritten values in boxes: 129.6, 105.3, 55.4</i></p>	<p><u>[18]</u> months ²⁴</p> <p>\leq <u>[4]</u> seconds</p>
<p>(4.9.G.2) SR 3.3.8.2.3 Perform a system functional test.</p>	<p><u>[18]</u> months ²⁴</p>

JUSTIFICATION FOR DEVIATIONS FROM NUREG-1433, REVISION 1
ITS: 3.3.8.2 - RPS ELECTRIC POWER MONITORING

1. The Applicability of ITS 3.3.8.2 has been revised to exclude MODES 3 and 4 consistent with the Applicability of RPS Functions in ITS 3.3.1.1, "Reactor Protection System (RPS) Instrumentation." In MODES 3 and 4, a control rod can only be withdrawn from a core cell containing one or more fuel assemblies in accordance with ITS 3.10.2, "Single Control Rod Withdrawal—Hot Shutdown," and ITS 3.10.3, "Single Control Withdrawal—Cold Shutdown," respectively. Therefore, ITS 3.10.2 and 3.10.3 include OPERABILITY requirements for RPS Functions (LCO 3.3.1.1) and control rods (LCO 3.9.5). Furthermore, since the RPS electric power monitoring assemblies support the RPS Functions, ITS 3.10.2 and ITS 3.10.3 have been modified to also include requirements for the RPS electric power monitoring assemblies to be OPERABLE when the RPS Functions are required to be OPERABLE.
2. Bracketed Required Actions D.2.1 and D.2.2 have been deleted since these requirements are not applicable to the Quad Cities 1 and 2 licensing basis for the RPS electric power monitoring assemblies.
3. The brackets have been removed and the proper plant specific information/value has been provided.

B 3.3 INSTRUMENTATION

B 3.3.1.1 Reactor Protection System (RPS) Instrumentation

BASES

BACKGROUND

The RPS initiates a reactor scram when one or more monitored parameters exceed their specified limits, to preserve the integrity of the fuel cladding and the Reactor Coolant System (RCS) and minimize the energy that must be absorbed following a loss of coolant accident (LOCA). This can be accomplished either automatically or manually.

pressure boundary (RCPB)

2

1

2

The protection and monitoring functions of the RPS have been designed to ensure safe operation of the reactor. This is achieved by specifying limiting safety system settings (LSSS) in terms of parameters directly monitored by the RPS, as well as LCOs on other reactor system parameters and equipment performance. The LSSS are defined in this Specification as the Allowable Values, which, in conjunction with the LCOs, establish the threshold for protective system action to prevent exceeding acceptable limits, including Safety Limits (SLs) during Design Basis Accidents (DBAs).

described

3

Section 7.2

The RPS, as shown in the FSAR, Figure 1 (Ref. 1), includes sensors, relays, bypass circuits, and switches that are necessary to cause initiation of a reactor scram. Functional diversity is provided by monitoring a wide range of dependent and independent parameters. The input parameters to the scram logic are from instrumentation that monitors reactor vessel water level, reactor vessel pressure, neutron flux, main steam line isolation valve position, turbine control valve (TCV) fast closure, pressure, turbine stop valve (TSV) position, drywell pressure, and steam discharge volume (SDV) water level, as well as reactor mode switch in shutdown position and manual scram signals. There are at least four redundant sensor input signals from each of these parameters (with the exception of the reactor mode switch in shutdown/scram signal). Most channels include electronic equipment (e.g., trip units) that compares measured input signals with pre-established setpoints. When the setpoint is exceeded, the channel output relay actuates, which then outputs an RPS trip signal to the trip logic. Table B 3.3.1.1-1 summarizes the diversity of sensors capable of initiating scrams during anticipated operating transients typically analyzed.

2

2

and turbine condenser vacuum

3

and manual

5

5

(continued)

All changes are [3] unless otherwise identified

BASES

three automatic logic channels described

BACKGROUND
(continued)

The RPS is comprised of two independent trip systems (A and B) with ~~two~~ ^{three} logic channels in each trip system (logic channels A1 and A2, B1 and B2) as ~~shown~~ in Reference 1. The ~~outputs of the logic channels~~ ^{automatic} in a trip system are combined in a one-out-of-two logic so that either channel can trip the associated trip system. The tripping of both trip systems will produce a reactor scram. This logic arrangement is referred to as a one-out-of-two taken twice logic. Each trip system can be reset by use of a reset switch. If a full scram occurs (both trip systems trip), a relay prevents reset of the trip systems for 10 seconds after the full/scram signal is received. This 10 second delay on reset ensures that the scram function will be completed.

and manual logic channel A3

automatic

and manual logic channel B3

Insert BK60-1

and after the reactor mode switch is placed in the shutdown position

Two scram pilot valves are located in the hydraulic control unit for each control rod drive (CRD). Each scram pilot valve is solenoid operated, with the solenoids normally energized. The scram pilot valves control the air supply to the scram inlet and outlet valves for the associated CRD. When either scram pilot valve solenoid is energized, air pressure holds the scram valves closed and, therefore, both scram pilot valve solenoids must be de-energized to cause a control rod to scram. The scram valves control the supply and discharge paths for the CRD water during a scram. One of the scram pilot valve solenoids for each CRD is controlled by trip system A, and the other solenoid is controlled by trip system B. Any trip of trip system A in conjunction with any trip in trip system B results in de-energizing both solenoids, air bleeding off, scram valves opening, and control rod scram.

The backup scram valves, which energize on a scram signal to depressurize the scram air header, are also controlled by the RPS. Additionally, the RPS System controls the SDV vent and drain valves such that when both trip systems trip, the SDV vent and drain valves close to isolate the SDV.

APPLICABLE SAFETY ANALYSES, LCO, and APPLICABILITY

and 4

The actions of the RPS are assumed in the safety analyses of References 1, 2, and 3. The RPS initiates a reactor scram when monitored parameter values exceed the Allowable Values, specified by the setpoint methodology and listed in Table 3.3.1.1-1 to preserve the integrity of the fuel cladding, the ~~reactor coolant pressure boundary (RCPB)~~, and

2

(continued)

3

INSERT BKGD-1

There are four RPS channel test switches, one associated with each of the four automatic trip channels. These test switches allow the operator to test the OPERABILITY of the individual trip channel automatic scram contactors. In addition, trip channels A3 and B3 (one trip channel per trip system) are provided for manual scram. Placing the reactor mode switch in shutdown position or depressing both manual scram push buttons (one per trip system) will initiate the manual trip function.

BASES

APPLICABLE
SAFETY ANALYSES,
LCD, and
APPLICABILITY
(continued)

the containment by minimizing the energy that must be absorbed following a LOCA.

10 CFR 50.36(e)(2)(ii)

RPS instrumentation satisfies Criterion 3 of the NRC Policy Statement. Functions not specifically credited in the accident analysis are retained for the overall redundancy and diversity of the RPS as required by the NRC approved licensing basis.

3

The OPERABILITY of the RPS is dependent on the OPERABILITY of the individual instrumentation channel Functions specified in Table 3.3.1.1-1. Each Function must have a required number of OPERABLE channels per RPS trip system, with their setpoints within the specified Allowable Value, where appropriate. The actual setpoint is calibrated consistent with applicable setpoint methodology assumptions. Each channel must also respond within its assumed response time.

where appropriate

2

Allowable Values are specified for each RPS Function specified in the Table. Nominal trip setpoints are specified in the setpoint calculations. The nominal setpoints are selected to ensure that the actual setpoints do not exceed the Allowable Value between successive CHANNEL CALIBRATIONS. Operation with a trip setpoint less conservative than the nominal trip setpoint, but within its Allowable Value, is acceptable. A channel is inoperable if its actual trip setpoint is not within its required Allowable Value.

3

For nuclear instrumentation functions (i.e., Functions 1.a, 2.a, 2.b, and 2.c)

Trip setpoints are those predetermined values of output at which an action should take place. The setpoints are compared to the actual process parameter (e.g., reactor vessel water level), and when the measured output value of the process parameter exceeds the setpoint, the associated device (e.g., trip unit) changes state. The analytic limits are derived from the limiting values of the process parameters obtained from the safety analysis. The Allowable Values are derived from the analytic limits, corrected for calibration, process, and some of the instrument errors. The trip setpoints are then determined accounting for the remaining instrument errors (e.g., drift). The trip setpoints derived in this manner provide adequate protection because instrumentation uncertainties, process effects, calibration tolerances, instrument drift, and severe

3

for these Functions

(continued)

All changes are [G] unless otherwise indicated

and appropriately applied for the instrumentation [3]

BASES

APPLICABLE SAFETY ANALYSES, LCO, and APPLICABILITY (continued)

[3]

Insert ASA

or other conditions

The only MODES specified in Table 3.3.1.1-1 are MODES 1 and 2, and

environment errors (for channels that must function in harsh environments as defined by 10 CFR 50.49) are accounted for.

The OPERABILITY of scram pilot valves and associated solenoids, backup scram valves, and SDV valves, described in the Background section, are not addressed by this LCO.

The individual Functions are required to be OPERABLE in the MODES specified in the table, which may require an RPS trip to mitigate the consequences of a design basis accident or transient. To ensure a reliable scram function, a combination of Functions are required in each MODE to provide primary and diverse initiation signals.

In MODE 5,

The RPS is required to be OPERABLE in MODE 5 with any control rod withdrawn from a core cell containing one or more fuel assemblies. Control rods withdrawn from a core cell containing no fuel assemblies do not affect the reactivity of the core and, therefore, are not required to have the capability to scram. Provided all other control rods remain inserted, ~~the~~ RPS function is ~~not~~ required. In this condition, the required SDM (LCO 3.1.1) and refuel position one-rod-out interlock (LCO 3.9.2) ensure that no event requiring RPS will occur. During normal operation in MODES 3 and 4, all control rods are fully inserted and the Reactor Mode Switch Shutdown Position control rod withdrawal block (LCO 3.3.2.1) does not allow any control rod to be withdrawn. Under these conditions, the RPS function is not required to be OPERABLE.

since

No RPS Function is required

The specific Applicable Safety Analyses, LCO, and Applicability discussions are listed below on a Function by Function basis.

Intermediate Range Monitor (IRM)

1.a. Intermediate Range Monitor Neutron Flux—High

The IRMs monitor neutron flux levels from the upper range of the source range monitor (SRM) to the lower range of the average power range monitors (APRMs). The IRMs are capable of generating trip signals that can be used to prevent fuel damage resulting from abnormal operating transients in the intermediate power range. In this power range, the most significant source of reactivity change is due to control

(continued)

3

INSERT ASA

For all Functions other than those associated with nuclear instrumentation (i.e., other than Functions 1.a, 2.a, 2.b, and 2.c) the trip setpoints are determined from the analytic limits, corrected for defined process, calibration, and instrument errors. The Allowable Values are then determined, based on the trip setpoint values, by accounting for the calibration based errors. These calibration based errors are limited to reference accuracy, instrument drift, errors associated with measurement and test equipment, and calibration tolerance of loop components. The trip setpoints and Allowable Values determined in this manner provide adequate protection because instrument uncertainties, process effects, calibration tolerances, instrument drift, and severe environment errors (for channels that must function in harsh environments as defined by 10 CFR 50.49) are accounted for and appropriately applied for the instrumentation.

All changes are [3] unless otherwise indicated

BASES

APPLICABLE SAFETY ANALYSES, LCO, and APPLICABILITY

1.a. Intermediate Range Monitor Neutron Flux—High (continued)

Function from

rod withdrawal. The IRM provides ⁽²⁾ diverse protection ⁽²⁾ for the rod worth minimizer (RWM), which monitors and controls the movement of control rods at low power. The RWM prevents the withdrawal of an out of sequence control rod during startup that could result in an unacceptable neutron flux excursion (Ref. 2). The IRM provides mitigation of the neutron flux excursion. To demonstrate the capability of the IRM System to mitigate control rod withdrawal events, generic analyses ⁽⁵⁾ have been performed (Ref. 2) to evaluate the consequences of control rod withdrawal events during startup that are mitigated only by the IRM. This analysis, which assumes that one IRM channel in each trip system is bypassed, demonstrates that the IRMs provide protection against local control rod withdrawal errors and results in peak fuel ~~Energy Deposition~~ ⁽²⁾ enthalpy below the 170 cal/gm fuel failure threshold criterion.

The IRMs are also capable of limiting other reactivity excursions during startup, such as cold water injection events, although no credit is specifically assumed.

⁽⁶⁾ The IRM System is divided into two groups of IRM channels, with four IRM channels inputting to each trip system. The analysis of Reference 2 assumes that one channel in each trip system is bypassed. Therefore, six channels with three channels in each trip system are required for IRM OPERABILITY to ensure that no single instrument failure will preclude a scram from this function on a valid signal. This trip is active in each of the 10 ranges of the IRM, which must be selected by the operator to maintain the neutron flux within the monitored level of an IRM range.

⁽⁶⁾ The analysis of Reference 2 has adequate conservatism to permit ⁽²⁾ the IRM Allowable Value ⁽²⁾ of 120 divisions of a 125 division scale.

specified in Table 3.3.1.1-1

The Intermediate Range Monitor Neutron Flux—High Function must be OPERABLE during MODE 2 when control rods may be withdrawn and the potential for criticality exists. In MODE 5, when a cell with fuel has its control rod withdrawn, the IRMs provide monitoring for and protection against unexpected reactivity excursions. In MODE 1, the APRM

(continued)

All changes are [3] unless otherwise indicated

RPS Instrumentation
B 3.3.1.1

BASES

APPLICABLE
SAFETY ANALYSES,
LCO, and
APPLICABILITY

1.a. Intermediate Range Monitor Neutron Flux—High
(continued)

System (2) the RMM, (3) and Rod Block Monitor provide protection against control rod withdrawal error events and the IRMs are not required.

[2] The IRMs are automatically bypassed when the Reactor Mode Switch is in the Run position.

1.b. Intermediate Range Monitor—Inop

This trip signal provides assurance that a minimum number of IRMs are OPERABLE. Anytime an IRM mode switch is moved to any position other than "Operate," the detector voltage drops below a preset level, or when a module is not plugged in, an inoperative trip signal will be received by the RPS unless the IRM is bypassed. Since only one IRM in each trip system may be bypassed, only one IRM in each RPS trip system may be inoperative without resulting in an RPS trip signal.

This Function was not specifically credited in the accident analysis but it is retained for the overall redundancy and diversity of the RPS as required by the NRC approved licensing basis.

Six channels of Intermediate Range Monitor—Inop with three channels in each trip system are required to be OPERABLE to ensure that no single instrument failure will preclude a scram from this function on a valid signal.

~~Since this Function is not assumed in the safety analysis, there is no Allowable Value for this function.~~ [2]

This Function is required to be OPERABLE when the Intermediate Range Monitor Neutron Flux—High Function is required.

Average Power Range Monitor

2.a. Average Power Range Monitor Neutron Flux—High Setdown

The APRM channels receive input signals from the local power range monitors (LPRMs) within the reactor core (2) to provide an indication of the power distribution and local power changes. The APRM channels average these LPRM signals to provide a continuous indication of average reactor power from a few percent to greater than RTP. For operation at

(continued)

BASES

**APPLICABLE
SAFETY ANALYSES,
LCO, and
APPLICABILITY**

2.a. Average Power Range Monitor Neutron Flux—High,
Setdown (continued)

low power (i.e., MODE 2), the Average Power Range Monitor Neutron Flux—High, Setdown Function is capable of generating a trip signal that prevents fuel damage resulting from abnormal operating transients in this power range. For most operation at low power levels, the Average Power Range Monitor Neutron Flux—High, Setdown Function will provide a secondary scram to the Intermediate Range Monitor Neutron Flux—High Function because of the relative setpoints. With the IRMs at Range 9 or 10, it is possible that the Average Power Range Monitor Neutron Flux—High, Setdown Function will provide the primary trip signal for a corewide increase in power.



No specific safety analyses take direct credit for the Average Power Range Monitor Neutron Flux—High, Setdown Function. However, this function indirectly ensures that before the reactor mode switch is placed in the run position, reactor power does not exceed 25% RTP (SL 2.1.1.1) when operating at low reactor pressure and low core flow. Therefore, it indirectly prevents fuel damage during significant reactivity increases with THERMAL POWER < 25% RTP.

The APRM System is divided into two groups of channels with three APRM channel inputs to each trip system. The system is designed to allow one channel in each trip system to be bypassed. Any one APRM channel in a trip system can cause the associated trip system to trip. Four channels of Average Power Range Monitor Neutron Flux—High, Setdown with two channels in each trip system are required to be OPERABLE to ensure that no single failure will preclude a scram from this Function on a valid signal. In addition, to provide adequate coverage of the entire core, at least ~~one~~ LPRM inputs are required for each APRM channel, with at least two LPRM inputs from each of the four axial levels at which the LPRMs are located.

50% of the
3

The Allowable Value is based on preventing significant increases in power when THERMAL POWER is < 25% RTP.

The Average Power Range Monitor Neutron Flux—High, Setdown Function must be OPERABLE during MODE 2 when control rods may be withdrawn ~~since the potential for criticality exists.~~

and the potential for fuel damage from abnormal operating transients

(continued)

All changes are [3] unless otherwise indicated

BASES

APPLICABLE SAFETY ANALYSES, LCO, and APPLICABILITY

2.a. Average Power Range Monitor Neutron Flux—High, Setdown (continued)

In MODE 1, the Average Power Range Monitor Neutron Flux—High Function provides protection against reactivity transients and the RWM and rod block monitor protect against control rod withdrawal error events.

2.b. Average Power Range Monitor Flow Biased ~~Thermal Power~~ ^{Simulated} Thermal Power—High

The Average Power Range Monitor Flow Biased ~~Thermal Power~~ ^{Simulated} Thermal Power—High Function monitors neutron flux to approximate the THERMAL POWER being transferred to the reactor coolant. The APRM neutron flux is electronically filtered with a time constant representative of the fuel heat transfer dynamics to generate a signal proportional to the THERMAL POWER in the reactor. The trip level is varied as a function of recirculation drive flow (i.e., at lower core flows, the setpoint is reduced proportional to the reduction in power experienced as core flow is reduced ~~with a fixed control rod pattern~~) but is clamped at an upper limit that is always lower than the Average Power Range Monitor Fixed Neutron Flux—High Function Allowable Value. The Average Power Range Monitor Flow Biased ~~Thermal Power~~ ^{Simulated} Thermal Power—High Function provides protection against transients where THERMAL POWER increases slowly (such as the loss of feedwater heating event) and protects the fuel cladding integrity by ensuring that the MCPR SL is not exceeded. During these events, the THERMAL POWER increase does not significantly lag the neutron flux response and, because of a lower trip setpoint, will initiate a scram before the high neutron flux scram. For rapid neutron flux increase events, the THERMAL POWER lags the neutron flux and the Average Power Range Monitor Fixed Neutron Flux—High Function will provide a scram signal before the Average Power Range Monitor Flow Biased Simulated Thermal Power—High Function setpoint is exceeded.

Neutron Flux

equivalent to

Neutron Flux

recirculation loop flow controller failure event with increasing flow and the

Insert Function 2.b.1

three

Channels providing

2

(continued)

3

INSERT Function 2.b.1

During any transient event that occurs at a reduced recirculation flow, because of a lower scram trip setpoint, the Average Power Range Monitor Flow Biased Neutron Flux-High Function will initiate a scram before the clamped Allowable Value is reached.

All changes are [3] unless otherwise identified

BASES

APPLICABLE
SAFETY ANALYSES,
LCO, and
APPLICABILITY

2.b. Average Power Range Monitor Flow Biased ~~Simulated~~ Thermal Power—High (continued)

Neutron Flux

Average Power Range Monitor Flow Biased ~~Simulated/Thermal~~ Power—High with two channels in each trip system arranged in a one-out-of-two logic are required to be OPERABLE to ensure that no single instrument failure will preclude a scram from this Function on a valid signal. In addition, to provide adequate coverage of the entire core, at least ~~two~~ LPRM inputs are required for each APRM channel, with at least two LPRM inputs from each of the four axial levels at which the LPRMs are located. Each APRM channel receives ~~two~~ total drive flow signal ~~representative of total core flow~~. The total drive flow signals are generated by ~~two~~ flow units, ~~one~~ of which supply signals to the trip system A APRMs, while the other ~~two~~ supply signals to the trip system B APRMs. Each flow ~~unit~~ signal is provided by summing up ~~the~~ flow signals from the two recirculation loops. To obtain the most conservative reference signals, the total flow signals from the two flow units (associated with a trip system as described above) are routed to a low auction circuit associated with each APRM. Each APRM's auction circuit selects the lower of the two flow unit signals for use as the scram trip reference for that particular APRM. Each required Average Power Range Monitor Flow Biased Simulated Thermal Power—High channel only requires an input from one OPERABLE flow unit, since the individual APRM channel will perform the intended function with only one OPERABLE flow unit input. However, in order to maintain single failure criteria for the Function, at least one required Average Power Range Monitor Flow Biased Simulated Thermal Power—High channel in each trip system must be capable of maintaining an OPERABLE flow unit signal in the event of a failure of an auction circuit, or a flow unit, in the associated trip system (e.g., if a flow unit is inoperable, one of the two required Average Power Range Monitor Flow Biased Simulated Thermal Power—High channels in the associated trip system must be considered inoperable).

50% of the

Converters

converter

one

one

two

ies

Insert Function 2.b.2

The clamped Allowable Value is based on analyses that take credit for the Average Power Range Monitor Flow Biased Simulated Thermal Power—High Function for the mitigation of the loss of feedwater heating event. The THERMAL POWER time constant of < 7 seconds is based on the fuel heat transfer

(continued)

3

INSERT Function 2.b.2

Each required Average Power Range Monitor Flow Biased Neutron Flux-High channel requires an input from one OPERABLE flow converter (e.g., if a converter unit is inoperable, the associated Average Power Range Monitor Flow Biased Neutron Flux-High channels must be considered inoperable). An APRM flow converter is considered inoperable whenever it cannot deliver a flow signal less than or equal to actual recirculation flow conditions for all steady state and transient reactor conditions while in MODE 1. Reduced flow or downscale flow converter conditions due to planned maintenance or testing activities during derated plant conditions (i.e., end of cycle coast down) will result in conservative setpoints for the APRM flow bias functions, thus maintaining the function OPERABLE.

The Allowable Value is selected to ensure the fuel cladding integrity by ensuring that the MCPR SL is not exceeded. "W," in the Allowable Value column of Table 3.3.1.1-1, is the percentage of recirculation loop flow which provides a rated core flow of 98 million lbs/hr.

BASES

Neutron Flux [3]

APPLICABLE SAFETY ANALYSES, LCO, and APPLICABILITY

2.b. Average Power Range Monitor Flow Biased ~~Simulated Thermal Power~~-High (continued)

dynamics and provides a signal proportional to the THERMAL POWER. [3]

The Average Power Range Monitor Flow Biased ~~Simulated Thermal Power~~-High Function is required to be OPERABLE in MODE 1 when there is the possibility of generating excessive THERMAL POWER and potentially exceeding the SL applicable to high pressure and core flow conditions (MCPR SL). During MODES 2 and 5, other IRM and APRM Functions provide protection for fuel cladding integrity.

2.c. Average Power Range Monitor Fixed Neutron Flux-High

The APRM channels provide the primary indication of neutron flux within the core and respond almost instantaneously to neutron flux increases. The Average Power Range Monitor Fixed Neutron Flux-High Function is capable of generating a trip signal to prevent fuel damage or excessive pressure. For the overpressurization protection analysis of Reference 8, the Average Power Range Monitor Fixed Neutron Flux-High Function is assumed to terminate the main steam isolation valve (MSIV) closure event and, along with the safety valves (SRVs), limits the peak reactor pressure vessel (RPV) pressure to less than the ASME Code limits. The control rod drop accident (CRDA) analysis (Ref. 8) takes credit for the Average Power Range Monitor Fixed Neutron Flux-High Function to terminate the CRDA.

2
Reactor Coolant System (RCS)

3
2
7

The APRM System is divided into two groups of channels with three APRM channels inputting to each trip system. The system is designed to allow one channel in each trip system to be bypassed. Any one APRM channel in a trip system can cause the associated trip system to trip. Four channels of Average Power Range Monitor Fixed Neutron Flux-High with two channels in each trip system arranged in a one-out-of-two logic are required to be OPERABLE to ensure that no single instrument failure will preclude a scram from this Function on a valid signal. In addition, to provide adequate coverage of the entire core, at least 50% of the LPRM inputs are required for each APRM channel, with at least two LPRM inputs from each of the four axial levels at which the LPRMs are located.

3
50% of the

(continued)

BASES

**APPLICABLE
SAFETY ANALYSES,
LCO, and
APPLICABILITY**

**2.c. Average Power Range Monitor Fixed Neutron Flux—High
(continued)**

The Allowable Value is based on the Analytical Limit assumed in the CRDA analyses.

The Average Power Range Monitor Fixed Neutron Flux—High Function is required to be OPERABLE in MODE 1 where the potential consequences of the analyzed transients could result in the SLs (e.g., MCPR and RCS pressure) being exceeded. Although the Average Power Range Monitor Fixed Neutron Flux—High Function is assumed in the CRDA analysis, which is applicable in MODE 2, the Average Power Range Monitor Neutron Flux—High, Setdown Function conservatively bounds the assumed trip and, together with the assumed IRM trips, provides adequate protection. Therefore, the Average Power Range Monitor Fixed Neutron Flux—High Function is not required in MODE 2.

(Ref. 7)
2

2.d. Average Power Range Monitor—Downscale

This signal ensures that there is adequate Neutron Monitoring System protection if the reactor mode switch is placed in the run position prior to the APRMs coming on scale. With the reactor mode switch in run, an APRM downscale signal coincident with an associated Intermediate Range Monitor Neutron Flux—High or Inop signal generates a trip signal. This function was not specifically credited in the accident analysis but it is retained for the overall redundancy and diversity of the RPS as required by the NRC approved licensing basis.

7

The APRM System is divided into two groups of channels with three inputs into each trip system. The system is designed to allow one channel in each trip system to be bypassed. Four channels of Average Power Range Monitor—Downscale with two channels in each trip system arranged in a one-out-of-two logic are required to be OPERABLE to ensure that no single failure will preclude a scram from this function on a valid signal. The Intermediate Range Monitor Neutron Flux—High and Inop Functions are also part of the OPERABILITY of the Average Power Range Monitor—Downscale Function (i.e., if either of these IRM Functions cannot send a signal to the Average Power Range Monitor—Downscale Function, the associated Average Power Range Monitor—Downscale channel is considered inoperable).

(continued)

BASES

APPLICABLE
SAFETY ANALYSES,
LCO, and
APPLICABILITY

2.d. Average Power Range Monitor—Downscale (continued)

The Allowable Value is based upon ensuring that the APRMs are in the linear scale range when transfers are made between APRMs and IRMs.

This Function is required to be OPERABLE in MODE 1 since this is when the APRMs are the primary indicators of reactor power.

7

d

2.e. Average Power Range Monitor—Inop

This signal provides assurance that a minimum number of APRMs are OPERABLE. Anytime an APRM mode switch is moved to any position other than "Operate," an APRM module is unplugged, ~~the electronic operating voltage is 10%~~, or the APRM has too few LPRM inputs (< 10), an inoperative trip signal will be received by the RPS, unless the APRM is bypassed. Since only one APRM in each trip system may be bypassed, only one APRM in each trip system may be inoperable without resulting in an RPS trip signal. This Function was not specifically credited in the accident analysis, but it is retained for the overall redundancy and diversity of the RPS as required by the NRC approved licensing basis.

50%

For any APRM

its

3

Four channels of Average Power Range Monitor—Inop with two channels in each trip system are required to be OPERABLE to ensure that no single failure will preclude a scram from this Function on a valid signal.

There is no Allowable Value for this Function.

This Function is required to be OPERABLE in the MODES where the APRM Functions are required.

other

2

3. Reactor Vessel Steam Dome Pressure—High

An increase in the RPV pressure during reactor operation compresses the steam voids and results in a positive reactivity insertion. This causes the neutron flux and THERMAL POWER transferred to the reactor coolant to increase, which could challenge the integrity of the fuel cladding and the RCPB. No specific safety analysis takes direct credit for this Function. However, the Reactor

(continued)

BASES

APPLICABLE
SAFETY ANALYSES,
LCO, and
APPLICABILITY

3. Reactor Vessel Steam Dome Pressure—High (continued)

Vessel Steam Dome Pressure—High Function initiates a scram for transients that results in a pressure increase, counteracting the pressure increase by rapidly reducing core power. For the overpressurization protection analysis of Reference 8, reactor scram (the analyses conservatively assume scram on the Average Power Range Monitor Fixed Neutron Flux—High signal, not the Reactor Vessel Steam Dome Pressure—High signal), along with the ~~SVPs~~, limits the peak RPV pressure to less than the ASME Section III Code limits.

2
3
2
or the Main Steam Isolation Valve—Closure

safety valves

High reactor pressure signals are initiated from four pressure transmitters that sense reactor pressure. The Reactor Vessel Steam Dome Pressure—High Allowable Value is chosen to provide a sufficient margin to the ASME Section III Code limits during the event.

Four channels of Reactor Vessel Steam Dome Pressure—High Function, with two channels in each trip system arranged in a one-out-of-two logic, are required to be OPERABLE to ensure that no single instrument failure will preclude a scram from this function on a valid signal. The Function is required to be OPERABLE in MODES 1 and 2 when the RCS is pressurized and the potential for pressure increase exists.

4. Reactor Vessel Water Level—Low (Level 3)

Low RPV water level indicates the capability to cool the fuel may be threatened. Should RPV water level decrease too far, fuel damage could result. Therefore, a reactor scram is initiated at Level 3 to substantially reduce the heat generated in the fuel from fission. The Reactor Vessel Water Level—Low (Level 3) Function is assumed, in the analysis of the recirculation line break (Ref. 6). The reactor scram reduces the amount of energy required to be absorbed and, along with the actions of the Emergency Core Cooling Systems (ECCS), ensures that the fuel peak cladding temperature remains below the limits of 10 CFR 50.46.

7
this level

3
and is credited in the loss of normal feedwater flow event (Ref. 9)

differential pressure

Reactor Vessel Water Level—Low (Level 3) signals are initiated from four (level) transmitters that sense the difference between the pressure due to a constant column of

(continued)

BASES

APPLICABLE
SAFETY ANALYSES,
LCO, and
APPLICABILITY

4. Reactor Vessel Water Level—Low, Level 3 (continued)

water (reference leg) and the pressure due to the actual water level (variable leg) in the vessel.

Four channels of Reactor Vessel Water Level—Low, Level 3 Function, with two channels in each trip system arranged in a one-out-of-two logic, are required to be OPERABLE to ensure that no single instrument failure will preclude a scram from this Function on a valid signal.

The Reactor Vessel Water Level—Low, Level 3 Allowable Value is selected to ensure that during normal operation the separator skirts are not uncovered (this protects available recirculation pump net positive suction head (NPSH) from significant carryunder) and, for transients involving loss of all normal feedwater flow, initiation of the low pressure ECCS subsystems at Reactor Vessel Water—Low, Level 3 will not be required.

The Function is required in MODES 1 and 2 where considerable energy exists in the RCS resulting in the limiting transients and accidents. ECCS initiations at Reactor Vessel Water Level—Low, Level 3 and Low, Level 1 provide sufficient protection for level transients in all other MODES.

5. Main Steam Isolation Valve—Closure

MSIV closure results in loss of the main turbine and the condenser as a heat sink for the nuclear steam supply system and indicates a need to shut down the reactor to reduce heat generation. Therefore, a reactor scram is initiated on a Main Steam Isolation Valve—Closure signal before the MSIVs are completely closed in anticipation of the complete loss of the normal heat sink and subsequent overpressurization transient. However, for the overpressurization protection analysis of Reference 2, the Average Power Range Monitor Fixed Neutron Flux—High Function, along with the SARVs, limits the peak RPV pressure to less than the ASME Code limits. That is, the direct scram on position switches for MSIV closure events is not assumed in the overpressurization analysis. Additionally, MSIV closure is assumed in the transients analyzed in Reference 2 (e.g., low steam line pressure, manual closure of MSIVs, high steam line flow).

3
2

3
Safety
values

4-3

(continued)

BASES

APPLICABLE SAFETY ANALYSES, LCO, and APPLICABILITY

5. Main Steam Isolation Valve—Closure (continued)

The reactor scram reduces the amount of energy required to be absorbed and, along with the actions of the ECCS, ensures that the fuel peak cladding temperature remains below the limits of 10 CFR 50.46.

which operates two contacts

and contact

In addition, certain combinations of valves closed in two lines will result in a half-scram

MSIV closure signals are initiated from position switches located on each of the eight MSIVs. Each MSIV has ~~two~~ ^{contact} position switches; one inputs to RPS trip system A while the other inputs to RPS trip system B. Thus, each RPS trip system receives an input from eight Main Steam Isolation Valve—Closure channels, each consisting of ~~one~~ ^a position switch. The logic for the Main Steam Isolation Valve—Closure Function is arranged such that either the inboard or outboard valve on three or more of the main steam lines must close in order for a scram to occur.

The Main Steam Isolation Valve—Closure Allowable Value is specified to ensure that a scram occurs prior to a significant reduction in steam flow, thereby reducing the severity of the subsequent pressure transient.

Sixteen channels of the Main Steam Isolation Valve—Closure Function, with eight channels in each trip system, are required to be OPERABLE to ensure that no single instrument failure will preclude the scram from this Function on a valid signal. This Function is only required in MODE 1 since, with the MSIVs open and the heat generation rate high, a pressurization transient can occur if the MSIVs close. In MODE 2, the heat generation rate is low enough so that the other diverse RPS functions provide sufficient protection.

3

assumed to scram the reactor for LOCAs inside primary containment (Ref. 3)

6. Drywell Pressure—High

High pressure in the drywell could indicate a break in the RCPB. A reactor scram is initiated to minimize the possibility of fuel damage and to reduce the amount of energy being added to the coolant and the drywell. The Drywell Pressure—High Function is a secondary scram signal to Reactor Vessel Water Level—Low, Level 3 for LOCA events inside the drywell. However, no credit is taken for a scram initiated from this Function for any of the DBAs analyzed in the SAR. This Function was not specifically credited in

(continued)

2

The reactor scram reduces the amount of energy required to be absorbed and, along with the actions of the ECCS, ensures that the fuel peak cladding temperature remains below the limits of 10 CFR 50.46.

BASES

APPLICABLE SAFETY ANALYSES, LCO, and APPLICABILITY

6. Drywell Pressure—High (continued)

the accident analysis, but it is retained for the overall redundancy and diversity of the RPS as required by the NRC approved licensing basis.

3

switches
3

High drywell pressure signals are initiated from four pressure transmitters that sense drywell pressure. The Allowable Value was selected to be as low as possible and indicative of a LOCA inside primary containment.

Four channels of Drywell Pressure—High Function, with two channels in each trip system arranged in a one-out-of-two logic, are required to be OPERABLE to ensure that no single instrument failure will preclude a scram from this Function on a valid signal. The Function is required in MODES 1 and 2 where considerable energy exists in the RCS, resulting in the limiting transients and accidents.

7a. 7b. Scram Discharge Volume Water Level—High

The SDV receives the water displaced by the motion of the CRD pistons during a reactor scram. Should this volume fill to a point where there is insufficient volume to accept the displaced water, control rod insertion would be hindered. Therefore, a reactor scram is initiated while the remaining free volume is still sufficient to accommodate the water from a full core scram. The two types of Scram Discharge Volume Water Level—High Functions are an input to the RPS logic. No credit is taken for a scram initiated from these Functions for any of the design basis accidents or transients analyzed in the FSAR. However, they are retained to ensure the RPS remains OPERABLE.

3
4

differential pressure

SDV water level is measured by two diverse methods. The level in each of the two SDVs is measured by two ~~level~~ transmitters and two thermal probes for a total of eight level signals. The outputs of these devices are arranged so that there is a signal from a ~~level~~ switch and a thermal probe to each RPS logic channel. The level measurement instrumentation satisfies the recommendations of Reference 10.

3

transmitters (and associated

differential pressure

10

(continued)

All changes are [3] unless otherwise identified

BASES

APPLICABLE
SAFETY ANALYSES,
LCO, and
APPLICABILITY

7a, 7b. Scram Discharge Volume Water Level—High
(continued)

The Allowable Value is chosen low enough to ensure that there is sufficient volume in the SDV to accommodate the water from a full scram.

Four channels of each type of Scram Discharge Volume Water Level—High Function, with two channels of each type in each trip system, are required to be OPERABLE to ensure that no single instrument failure will preclude a scram from these Functions on a valid signal. These Functions are required in MODES 1 and 2, and in MODE 5 with any control rod withdrawn from a core cell containing one or more fuel assemblies, since these are the MODES and other specified conditions when control rods are withdrawn. At all other times, this Function may be bypassed.

8. Turbine Stop Valve—Closure

Closure of the TSVs results in the loss of a heat sink that produces reactor pressure, neutron flux, and heat flux transients that must be limited. Therefore, a reactor scram is initiated at the start of TSV closure in anticipation of the transients that would result from the closure of these valves. The Turbine Stop Valve—Closure Function is the primary scram signal for the turbine trip event analyzed in Reference 0. For this event, the reactor scram reduces the amount of energy required to be absorbed and, along with the actions of the End of Cycle Recirculation Pump Trip (EOC-RPT) System, ensures that the MCPR SL is not exceeded.

(11)

Turbine Stop Valve—Closure signals are initiated from position switches located on each of the four TSVs. Two independent position switches are associated with each stop valve. One of the two switches provides input to RPS trip system A; the other, to RPS trip system B. Thus, each RPS trip system receives an input from four Turbine Stop Valve—Closure channels, each consisting of one position switch. The logic for the Turbine Stop Valve—Closure Function is such that three or more TSVs must be closed to produce a scram. This Function must be enabled at THERMAL POWER $\geq 40\%$ RTP. This is normally accomplished automatically by pressure transmitters sensing turbine first

contacts

A position switch and

contacts

(which is common to a channel in the other RPS trip system) and a switch contact

(45)

switches

(continued)

BASES

APPLICABLE
SAFETY ANALYSES,
LCO, and
APPLICABILITY

8. Turbine Stop Valve—Closure (continued)

stage pressure; therefore, to consider this function
OPERABLE, the turbine bypass valves must remain shut at
THERMAL POWER \geq 30% RTP.

opening
may affect this function

The Turbine Stop Valve—Closure Allowable Value is selected to be high enough to detect imminent TSV closure, thereby reducing the severity of the subsequent pressure transient.

Eight channels of Turbine Stop Valve—Closure Function, with four channels in each trip system, are required to be OPERABLE to ensure that no single instrument failure will preclude a scram from this Function if any three TSVs should close. This Function is required, consistent with analysis assumptions, whenever THERMAL POWER is \geq 30% RTP. This Function is not required when THERMAL POWER is $<$ 30% RTP since the Reactor Vessel Steam Dome Pressure—High and the Average Power Range Monitor Fixed Neutron Flux—High Functions are adequate to maintain the necessary safety margins.

9. Turbine Control Valve Fast Closure, Trip Oil Pressure—Low

Fast closure of the TCVs results in the loss of a heat sink that produces reactor pressure, neutron flux, and heat flux transients that must be limited. Therefore, a reactor scram is initiated on TCV fast closure in anticipation of the transients that would result from the closure of these valves. The Turbine Control Valve Fast Closure, Trip Oil Pressure—Low Function is the primary scram signal for the generator load rejection event analyzed in Reference 2. For this event, the reactor scram reduces the amount of energy required to be absorbed and along with the actions of the
EOC-RPT System, ensures that the MCPR SL is not exceeded.

Turbine Control Valve Fast Closure, Trip Oil Pressure—Low signals are initiated by the electrohydraulic control (EHC) fluid pressure at each control valve. One pressure ~~transmitter~~ is associated with each control valve, and the signal from each ~~transmitter~~ is assigned to a separate RPS logic channel. This Function must be enabled at THERMAL POWER \geq 30% RTP. This is normally accomplished

switch

45

(continued)

BASES

APPLICABLE
SAFETY ANALYSES,
LCO, and
APPLICABILITY

9. Turbine Control Valve Fast Closure, Trip Oil
Pressure—Low (continued)

automatically by pressure ~~transmitters~~ ^{switches} sensing turbine first stage pressure; therefore, ~~to consider this function~~ ^{opening} OPERABLE the turbine bypass valves ~~must remain shut at~~ ^{may affect this function} THERMAL POWER $\geq 30\%$ RTP.

The Turbine Control Valve Fast Closure, Trip Oil Pressure—Low Allowable Value is selected high enough to detect imminent TCV fast closure.

Four channels of Turbine Control Valve Fast Closure, Trip Oil Pressure—Low Function with two channels in each trip system arranged in a one-out-of-two logic are required to be OPERABLE to ensure that no single instrument failure will preclude a scram from this Function on a valid signal. This Function is required, consistent with the analysis assumptions, whenever THERMAL POWER is $\geq 30\%$ RTP. This Function is not required when THERMAL POWER is $< 30\%$ RTP, since the Reactor Vessel Steam Dome Pressure—High and the Average Power Range Monitor Fixed Neutron Flux—High Functions are adequate to maintain the necessary safety margins.

Insert
Function 10
7

10. Reactor Mode Switch—Shutdown Position

The Reactor Mode Switch—Shutdown Position Function provides signals, via the manual scram logic channels, ~~to each of the~~ ^{two} ~~four RPS logic channels~~, which are redundant to the automatic protective instrumentation channels and provide manual reactor trip capability. This Function was not specifically credited in the accident analysis, but it is retained for the overall redundancy and diversity of the RPS as required by the NRC approved licensing basis.

The reactor mode switch is a single switch with ~~four~~ ^{two} channels, each of which provides input into one of the RPS logic channels. ^{two manual scram}

There is no Allowable Value for this Function, since the channels are mechanically actuated based solely on reactor mode switch position.

(continued)

7

INSERT Function 10

10. Turbine Condenser Vacuum-Low

The Turbine Condenser Vacuum-Low Function is provided to shut down the reactor and reduce the energy input to the main condenser to help prevent overpressurization of the main condenser in the event of a loss of the main condenser vacuum. The Turbine Condenser Vacuum-Low Function is the primary scram signal for the loss of condenser vacuum event analyzed in Reference 9. For this event, the reactor scram reduces the amount of energy required to be absorbed by the main condenser and helps to ensure the MCPR SL is not exceeded by reducing the core energy prior to the fast closure of the turbine stop valves. This Function helps maintain the main condenser as a heat sink during this event.

Turbine condenser vacuum pressure signals are derived from four pressure switches that sense the pressure in the condenser. The Allowable Value was selected to reduce the severity of a loss of main condenser vacuum event by anticipating the transient and scrambling the reactor at a higher vacuum than the setpoints that close the turbine stop valves and bypass valves.

Four channels of Turbine Condenser Vacuum-Low Function, with two channels in each trip system arranged in a one-out-of-two logic, are required to be OPERABLE to ensure that no single instrument failure will preclude a scram from this Function on a valid signal. The Function is required in MODE 1 since in this MODE there is a significant amount of core energy that can be rejected to the main condenser. During MODES 2, 3, 4, and 5, the core energy is significantly lower. This Function is automatically bypassed with the reactor mode switch in any position other than run.

All changes are [3] unless otherwise indicated

BASES

APPLICABLE
SAFETY ANALYSES,
LCO, and
APPLICABILITY

11. Reactor Mode Switch—Shutdown Position (continued)

Four channels of Reactor Mode Switch—Shutdown Position Function, with ^{one} channels in each trip system, are available and required to be OPERABLE. The Reactor Mode Switch—Shutdown Position Function is required to be OPERABLE in MODES 1 and 2; and MODE 5 with any control rod withdrawn from a core cell containing one or more fuel assemblies, since these are the MODES and other specified conditions when control rods are withdrawn. manual

Two

12. Manual Scram

The Manual Scram push button channels provide signals, via the manual scram logic channels, ^(A3 and B3) to each of the four RPS logic channels, which are redundant to the automatic protective instrumentation channels and provide manual reactor trip capability. This Function was not specifically credited in the accident analysis but it is retained for the overall redundancy and diversity of the RPS as required by the NRC approved licensing basis. Two

There is one Manual Scram push button channel for each of the four RPS logic channels. In order to cause a scram it is necessary that ^{both} ~~at least one~~ channel in each trip system be actuated. 6

There is no Allowable Value for this Function since the channels are mechanically actuated based solely on the position of the push buttons.

Two ^{one} channels of Manual Scram with ^{one} channels in each trip system ~~arranged in a one-out-of-two logic~~ are available and required to be OPERABLE in MODES 1 and 2, and in MODE 5 with any control rod withdrawn from a core cell containing one or more fuel assemblies, since these are the MODES and other specified conditions when control rods are withdrawn. manual

ACTIONS

Reviewer's Note: Certain LCO Completion Times are based on approved topical reports. In order for a licensee to use the times, the licensee must justify the Completion Times as required by the staff Safety Evaluation Report (SER) for the topical report. 9

(continued)

BASES

ACTIONS
(continued)

① Note has been provided to modify the ACTIONS related to RPS instrumentation channels. Section 1.3, Completion Times, specifies that once a Condition has been entered, subsequent divisions, subsystems, components, or variables expressed in the Condition, discovered to be inoperable or not within limits, will not result in separate entry into the Condition. Section 1.3 also specifies that Required Actions of the Condition continue to apply for each additional failure, with Completion Times based on initial entry into the Condition. However, the Required Actions for inoperable RPS instrumentation channels provide appropriate compensatory measures for separate inoperable channels. As such, a Note has been provided that allows separate Condition entry for each inoperable RPS instrumentation channel.

7

Insert Note 2

A.1 and A.2

Because of the diversity of sensors available to provide trip signals and the redundancy of the RPS design, an allowable out of service time of 12 hours has been shown to be acceptable (Ref. ⑧) to permit restoration of any inoperable channel to OPERABLE status. However, this out of service time is only acceptable provided the associated Function's inoperable channel is in one trip system and the Function still maintains RPS trip capability (refer to Required Actions B.1, B.2, and C.1 Bases). If the inoperable channel cannot be restored to OPERABLE status within the allowable out of service time, the channel or the associated trip system must be placed in the tripped condition per Required Actions A.1 and A.2. Placing the inoperable channel in trip (or the associated trip system in trip) would conservatively compensate for the inoperability, restore capability to accommodate a single failure, and allow operation to continue. Alternatively, if it is not desired to place the channel (or trip system) in trip (e.g., as in the case where placing the inoperable channel in trip would result in a ~~scram~~ scram), Condition D must be entered and its Required Action taken.

required

The 12 hour allowance is not allowed for Reactor Mode Switch - Shutdown Position, and Manual Scram Function channels since with one channel inoperable RPS trip capability is not maintained. In this case, Condition C must be entered and its Required Actions taken.

B.1 and B.2

Condition B exists when, for any one or more Functions, at least one required channel is inoperable in each trip

(continued)

7

INSERT Note 2

Note 2 has been provided to modify the ACTIONS for the RPS instrumentation functions of APRM Flow Biased Neutron Flux-High (Function 2.b) and APRM Fixed Neutron Flux-High (Function 2.c) when they are inoperable due to failure of SR 3.3.1.1.2 and gain adjustments are necessary. Note 2 allows entry into associated Conditions and Required Actions to be delayed for up to 2 hours if the gain adjustment factor (GAF) is high (non-conservative), and for up to 12 hours if the GAF is low (conservative). The GAF for any channel is defined as the power value determined by the heat balance divided by the APRM reading for that channel. Upon completion of the gain adjustment, or expiration of the allowed time, the channel must be returned to OPERABLE status or the applicable Condition entered and the Required Actions taken. This Note is based on the time required to perform gain adjustments on multiple channels and additional time is allowed when the GAF is out of limits but conservative.

BASES

ACTIONS

B.1 and B.2 (continued)

system. In this condition, provided at least one channel per trip system is OPERABLE, the RPS still maintains trip capability for that Function, but cannot accommodate a single failure in either trip system.

Required Actions B.1 and B.2 limit the time the RPS scram logic, for any Function, would not accommodate single failure in both trip systems (e.g., one-out-of-one and one-out-of-one arrangement for a typical four channel Function). The reduced reliability of this logic arrangement was not evaluated in Reference ① for the 12 hour Completion Time. Within the 6 hour allowance, the associated Function will have all required channels OPERABLE or in trip (or any combination) in one trip system.

3

13

Completing one of these Required Actions restores RPS to a reliability level equivalent to that evaluated in Reference ①, which justified a 12 hour allowable out of service time as presented in Condition A. The trip system in the more degraded state should be placed in trip or, alternatively, all the inoperable channels in that trip system should be placed in trip (e.g., a trip system with two inoperable channels could be in a more degraded state than a trip system with four inoperable channels if the two inoperable channels are in the same Function while the four inoperable channels are all in different Functions). The decision of which trip system is in the more degraded state should be based on prudent judgment and take into account current plant conditions (i.e., what MODE the plant is in). If this action would result in a scram ~~OR RPD~~, it is permissible to place the other trip system or its inoperable channels in trip.

3

The 6 hour Completion Time is judged acceptable based on the remaining capability to trip, the diversity of the sensors available to provide the trip signals, the low probability of extensive numbers of inoperabilities affecting all diverse Functions, and the low probability of an event requiring the initiation of a scram.

Alternately, if it is not desired to place the inoperable channels (or one trip system) in trip (e.g., as in the case where placing the inoperable channel or associated trip

(continued)

BASES

ACTIONS

B.1 and B.2 (continued)

system in trip would result in a scram (of RPT), Condition D must be entered and its Required Action taken.

3

The 6 hour allowance is not allowed for Reactor Mode Switch - Shutdown and Manual Scram Function channels since with two channels inoperable RPS trip capability is not maintained. In this case, Condition C must be entered and its Required Action taken.

3

C.1

Required Action C.1 is intended to ensure that appropriate actions are taken if multiple, inoperable, untripped channels within the same trip system for the same Function result in the Function not maintaining RPS trip capability. A Function is considered to be maintaining RPS trip capability when sufficient channels are OPERABLE or in trip (or the associated trip system is in trip), such that both trip systems will generate a trip signal from the given Function on a valid signal. For the typical Function with one-out-of-two taken twice logic and the IRM and APRM Functions, this would require both trip systems to have one channel OPERABLE or in trip (or the associated trip system in trip). For Function 5 (Main Steam Isolation Valve-Closure), this would require both trip systems to have each channel associated with the MSIVs in three main steam lines (not necessarily the same main steam lines for both trip systems) OPERABLE or in trip (or the associated trip system in trip).

2

For Function 8 (Turbine Stop Valve-Closure), this would require both trip systems to have three channels, each OPERABLE or in trip (or the associated trip system in trip).

The Completion Time is intended to allow the operator time to evaluate and repair any discovered inoperabilities. The 1 hour Completion Time is acceptable because it minimizes risk while allowing time for restoration or tripping of channels.

D.1

Required Action D.1 directs entry into the appropriate Condition referenced in Table 3.3.1.1-1. The applicable Condition specified in the Table is Function and MODE or other specified condition dependent and may change as the Required Action of a previous Condition is completed. Each time an inoperable channel has not met any Required Action

(continued)

BASES

ACTIONS

D.1 (continued)

of Condition A, B, or C and the associated Completion Time has expired, Condition D will be entered for that channel and provides for transfer to the appropriate subsequent Condition.

E.1, F.1, and G.1

If the channel(s) is not restored to OPERABLE status or placed in trip (or the associated trip system placed in trip) within the allowed Completion Time, the plant must be placed in a MODE or other specified condition in which the LCO does not apply. The allowed Completion Times are reasonable, based on operating experience, to reach the specified condition from full power conditions in an orderly manner and without challenging plant systems. In addition, the Completion Time of Required Action E.1 is consistent with the Completion Time provided in LCO 3.2.2, "MINIMUM CRITICAL POWER RATIO (MCPR)."

H.1

If the channel(s) is not restored to OPERABLE status or placed in trip (or the associated trip system placed in trip) within the allowed Completion Time, the plant must be placed in a MODE or other specified condition in which the LCO does not apply. This is done by immediately initiating action to fully insert all insertable control rods in core cells containing one or more fuel assemblies. Control rods in core cells containing no fuel assemblies do not affect the reactivity of the core and are, therefore, not required to be inserted. Action must continue until all insertable control rods in core cells containing one or more fuel assemblies are fully inserted.

**SURVEILLANCE
REQUIREMENTS**

Reviewer's Note: Certain Frequencies are based on approved topical reports. In order for a licensee to use these Frequencies, the licensee must justify the Frequencies as required by the staff SER for the topical report.

(continued)

BASES

**SURVEILLANCE
REQUIREMENTS**
(continued)

As noted at the beginning of the SRs, the SRs for each RPS instrumentation Function are located in the SRs column of Table 3.3.1.1-1.

The Surveillances are modified by a Note to indicate that when a channel is placed in an inoperable status solely for performance of required Surveillances, entry into associated Conditions and Required Actions may be delayed for up to 6 hours, provided the associated Function maintains RPS trip capability. Upon completion of the Surveillance, or expiration of the 6 hour allowance, the channel must be returned to OPERABLE status or the applicable Condition entered and Required Actions taken. This Note is based on the reliability analysis (Ref. ②) assumption of the average time required to perform channel Surveillance. That analysis demonstrated that the 6 hour testing allowance does not significantly reduce the probability that the RPS will trip when necessary. (13)

SR 3.3.1.1.1

Performance of the CHANNEL CHECK once every 12 hours ensures that a gross failure of instrumentation has not occurred. A CHANNEL CHECK is normally a comparison of the parameter indicated on one channel to a similar parameter on other channels. It is based on the assumption that instrument channels monitoring the same parameter should read approximately the same value. Significant deviations between instrument channels could be an indication of excessive instrument drift in one of the channels or something even more serious. A CHANNEL CHECK will detect gross channel failure; thus, it is key to verifying the instrumentation continues to operate properly between each CHANNEL CALIBRATION.

Agreement criteria are determined by the plant staff based on a combination of the channel instrument uncertainties, including indication and readability. If a channel is outside the criteria, it may be an indication that the instrument has drifted outside its limit.

The Frequency is based upon operating experience that demonstrates channel failure is rare. The CHANNEL CHECK supplements less formal, but more frequent, checks of

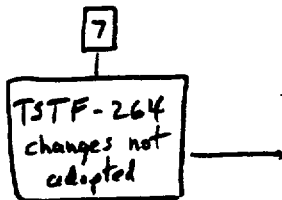

(continued)

BASES

SURVEILLANCE
REQUIREMENTS

SR 3.3.1.1.1 (continued)

channels during normal operational use of the displays associated with the channels required by the LCO.

SR 3.3.1.1.2

To ensure that the APRMs are accurately indicating the true core average power, the APRMs are calibrated to the reactor power calculated from a heat balance. LCO 3.2.4. "Average Power Range Monitor (APRM) Gain and Setpoint" allows the APRMs to be reading greater than actual THERMAL POWER to compensate for localized power peaking. When this adjustment is made, the requirement for the APRMs to indicate within 2% RTP of calculated power is modified to require the APRMs to indicate within 2% RTP of ~~calculated~~ ~~APRMs~~. The Frequency of once per 7 days is based on minor changes in LPRM sensitivity, which could affect the APRM reading between performances of SR 3.3.1.1.0.

3
Value established by SR 3.2.4.2

allowance

1

the 3

10 7

6

performed

and LHGR

A restriction to satisfying this SR when < 25% RTP is provided that requires the SR to be ~~met~~ only at ≥ 25% RTP because it is difficult to accurately maintain APRM indication of core THERMAL POWER consistent with a heat balance when < 25% RTP. At low power levels, a high degree of accuracy is unnecessary because of the large, inherent margin to thermal limits (MCPR and APLHGR). At ≥ 25% RTP, the Surveillance is required to have been satisfactorily performed within the last 7 days, in accordance with SR 3.0.2. A Note is provided which allows an increase in THERMAL POWER above 25% if the 7 day Frequency is not met per SR 3.0.2. In this event, the SR must be performed within 12 hours after reaching or exceeding 25% RTP. Twelve hours is based on operating experience and in consideration of providing a reasonable time in which to complete the SR.

SR 3.3.1.1.3

The Average Power Range Monitor Flow Biased ~~Stimulated~~ ~~Thermal Power~~—High Function uses the recirculation loop drive flows to vary the trip setpoint. This SR ensures that the total loop drive flow signals from the flow ~~units~~ used to vary the setpoint is appropriately compared to a calibrated flow signal and, therefore, the APRM Function

Neutron Flux 3

3
converters

(continued)

BASES

SURVEILLANCE
REQUIREMENTS

SR 3.3.1.1.3 (continued)

100 accurately reflects the required setpoint as a function of flow. Each flow signal from the respective flow UNIT must be $\leq 0.5\%$ of the calibrated flow signal. If the flow UNIT signal is not within the limit, the required APRM that receives an input from the inoperable flow UNIT must be declared inoperable.

Converter
all Converter
3

The Frequency of 7 days is based on engineering judgment, operating experience, and the reliability of this instrumentation.

SR 3.3.1.1.4 and SR 3.3.1.1.8 6

2 A CHANNEL FUNCTIONAL TEST is performed on each required channel to ensure that the entire channel will perform the intended function. 2

Any setpoint adjustment shall be consistent with the assumptions of the current plant specific setpoint methodology.

As noted, SR 3.3.1.1.4 is not required to be performed when entering MODE 2 from MODE 1, since testing of the MODE 2 required IRM and APRM Functions cannot be performed in MODE 1 without utilizing jumpers, lifted leads, or movable links. This allows entry into MODE 2 if the 7 day Frequency is not met per SR 3.0.2. In this event, the SR must be performed within 24 hours after entering MODE 2 from MODE 1. twelve hours is based on operating experience and in consideration of providing a reasonable time in which to complete the SR.

7
Insert
SR 3.3.1.1.8-1

for SR 3.3.1.1.4 7
A Frequency of 7 days provides an acceptable level of system average unavailability over the Frequency interval and is based on reliability analysis (Ref. 9). 13

7
Insert
SR 3.3.1.1.5

SR 3.3.1.1.5
A CHANNEL FUNCTIONAL TEST is performed on each required channel to ensure that the entire channel will perform the intended function. A Frequency of 7 days provides an acceptable level of system average availability over the

(continued)

7

INSERT SR 3.3.1.1.8-1

The Frequency of 31 days for SR 3.3.1.1.8 is acceptable based on engineering judgment, operating experience, and the reliability of this instrumentation.

7

INSERT SR 3.3.1.1.5

A functional test of each automatic scram contactor is performed to ensure that each automatic RPS logic channel will perform the intended function. There are four RPS channel test switches, one associated with each of the four automatic trip channels (A1, A2, B1, and B2). These test switches allow the operator to test the OPERABILITY of the individual trip logic channel automatic scram contactors as an alternative to using an automatic scram function trip. This is accomplished by placing the RPS channel test switch in the test position, which will input a trip signal into the associated RPS logic channel. The RPS channel test switches are not specifically credited in the accident analysis. The Manual Scram Functions are not configured the same as the generic model used in Reference 13. However, Reference 13 concluded that the Surveillance Frequency extensions for RPS Functions were not affected by the difference in configuration since each automatic RPS logic channel has a test switch which is functionally the same as the manual scram switches in the generic model. As such, a functional test of each RPS automatic scram contactor using either its associated test switch or by test of any of the associated automatic RPS Functions is required to be performed once every 7 days. The Frequency of 7 days is based on the reliability analysis of Reference 13.

BASES

SURVEILLANCE
REQUIREMENTS

SR 3.3.1.1.5 (continued)

Frequency and is based on the reliability analysis of Reference 10 (The Manual Scram Function's CHANNEL FUNCTIONAL TEST Frequency was credited in the analysis to extend many automatic scram Functions' Frequencies.)

7

SR 3.3.1.1.6 and SR 3.3.1.1.7

These Surveillances are established to ensure that no gaps in neutron flux indication exist from subcritical to power operation for monitoring core reactivity status.

The overlap between SRMs and IRMs is required to be demonstrated to ensure that reactor power will not be increased into a neutron flux region without adequate indication. This is required prior to withdrawing SRMs from the fully inserted position since indication is being transitioned from the SRMs to the IRMs.

fully

7

The overlap between IRMs and APRMs is of concern when reducing power into the IRM range. On power increases, the system design will prevent further increases (by initiating a rod block) if adequate overlap is not maintained.

Overlap between IRMs and APRMs exists when sufficient IRMs and APRMs concurrently have onscale readings such that the transition between MODE 1 and MODE 2 can be made without either APRM downscale rod block, or IRM upscale rod block. Overlap between SRMs and IRMs similarly exists when, prior to withdrawing the SRMs from the fully inserted position, IRMs are above mid-scale on range 1 before SRMs have reached the upscale rod block.

3

7
TSTF-264
changes not
adopted

The IRM/APRM
and SRM/IRM
overlaps are
acceptable if a
1/2 decade overlap
exists

3

As noted, SR 3.3.1.1.7 is only required to be met during entry into MODE 2 from MODE 1. That is, after the overlap requirement has been met and indication has transitioned to the IRMs, maintaining overlap is not required (APRMs may be reading downscale once in MODE 2).

If overlap for a group of channels is not demonstrated (e.g., IRM/APRM overlap), the reason for the failure of the Surveillance should be determined and the appropriate channel(s) declared inoperable. Only those appropriate channels that are required in the current MODE or condition should be declared inoperable.

(continued)

BASES

SURVEILLANCE REQUIREMENTS

SR 3.3.1.1.6 and SR 3.3.1.1.7 (continued)

A Frequency of 7 days is reasonable based on engineering judgment and the reliability of the IRMs and APRMs.

SR 3.3.1.1.8

2000 effective full power hours (EFPH)

LPRM gain settings are determined from the local flux profiles measured by the Traversing Incore Probe (TIP) System. This establishes the relative local flux profile for appropriate representative input to the APRM System. The ~~(92 DAY)~~ Frequency is based on operating experience with LPRM sensitivity changes.

SR 3.3.1.1.9 and SR 3.3.1.1.10

A CHANNEL FUNCTIONAL TEST is performed on each required channel to ensure that the ~~(APRM)~~ channel will perform the intended function. Any setpoint adjustment shall be consistent with the assumptions of the current plant specific setpoint methodology. The 92 day Frequency of SR 3.3.1.1.9 is based on the reliability analysis of Reference 9.

The 13 month Frequency is based on the need to perform this Surveillance under the conditions that apply during a plant outage and the potential for an unplanned transient if the Surveillance were performed with the reactor at power. Operating experience has shown that these components usually pass the Surveillance when performed at the 13 month Frequency.

SR 3.3.1.1.11

Calibration of trip units provides a check of the actual trip setpoints. The channel must be declared inoperable if the trip setting is discovered to be less conservative than the Allowable Value specified in Table 3.3.1.1-1. If the trip setting is discovered to be less conservative than accounted for in the appropriate setpoint methodology, but is not beyond the Allowable Value, the channel performance is still within the requirements of the plant safety analysis. Under these conditions, the setpoint must be

(continued)

All changes are [7] unless otherwise indicated

BASES

SURVEILLANCE
REQUIREMENTS

SR 3.3.1.1.10 (continued)

readjusted to be equal to or more conservative than accounted for in the appropriate setpoint methodology.

The Frequency of 92 days is based on the reliability analysis of Reference 6.

SR 3.3.1.1, 12,

SR 3.3.1.1.10 and SR 3.3.1.1.12

A CHANNEL CALIBRATION is a complete check of the instrument loop and the sensor. This test verifies that the channel responds to the measured parameter within the necessary range and accuracy. CHANNEL CALIBRATION leaves the channel adjusted to account for instrument drifts between successive calibrations consistent with the plant specific setpoint methodology.

to SR 3.3.1.1.14 and SR 3.3.1.1.16

Note 1 states that neutron detectors are excluded from CHANNEL CALIBRATION because they are passive devices, with minimal drift, and because of the difficulty of simulating a meaningful signal. Changes in neutron detector sensitivity are compensated for by performing the 7 day calorimetric calibration (SR 3.3.1.1.2) and the ~~CODE MODE 1~~ LPRM calibration against the TIPs (SR 3.3.1.1.10). A second Note is provided that requires the APRM and IRM SRs to be performed within 24 hours of entering MODE 2 from MODE 1. Testing of the MODE 2 APRM and IRM Functions cannot be performed in MODE 1 without utilizing jumpers, lifted leads, or movable links. This Note allows entry into MODE 2 from MODE 1 if the associated Frequency is not met per SR 3.0.2. ~~Twelve~~ hours is based on operating experience and in consideration of providing a reasonable time in which to complete the SR.

2000 EFPW

2 For the APRMs

Note 3 to SR 3.3.1.1.14 states that for Function 2b, this SR is not required for the flow portion of these channels. This allowance is consistent with the plant specific setpoint methodology. This portion of the Function 2b channels must be calibrated in accordance with SR 3.3.1.1.16.

Twenty four

The Frequency of SR 3.3.1.1.10 is based upon the assumption of a 184 day calibration interval in the determination of the magnitude of equipment drift in the setpoint analysis. The Frequency of SR 3.3.1.1.10 is based upon the assumption of a 12 month calibration interval in the determination of the magnitude of equipment drift in the setpoint analysis.

The Frequency of SR 3.3.1.1.12 is based upon the assumption of a 92 day calibration interval in determination of the magnitude of equipment drift in the setpoint analysis.

(continued)

BASES

SURVEILLANCE
REQUIREMENTS
(continued)

SR 3.3.1.1.14

The Average Power Range Monitor Flow Biased Simulated Thermal Power—High Function uses an electronic filter circuit to generate a signal proportional to the core THERMAL POWER from the APRM neutron flux signal. This filter circuit is representative of the fuel heat transfer dynamics that produce the relationship between the neutron flux and the core THERMAL POWER. The Surveillance filter time constant must be verified to be ≤ 7 seconds to ensure that the channel is accurately reflecting the desired parameter.

The Frequency of 18 months is based on engineering judgment considering the reliability of the components.

7

SR 3.3.1.1.16

7 7

(LSFT) - 2

The LOGIC SYSTEM FUNCTIONAL TEST demonstrates the OPERABILITY of the required trip logic for a specific channel. The functional testing of control rods (LCO 3.1.3), and SDV vent and drain valves (LCO 3.1.8), overlaps this Surveillance to provide complete testing of the assumed safety function.

The 16 month Frequency is based on the need to perform this Surveillance under the conditions that apply during a plant outage and the potential for an unplanned transient if the Surveillance were performed with the reactor at power. Operating experience has shown that these components usually pass the Surveillance when performed at the 18 month Frequency.

24
7

24 7

SR 3.3.1.1.16

3 7

This SR ensures that scrams initiated from the Turbine Stop Valve—Closure and Turbine Control Valve Fast Closure, Trip Oil Pressure—Low Functions will not be inadvertently bypassed when THERMAL POWER is $\geq 80\%$ RTP. This involves calibration of the bypass channels. Adequate margins for the instrument setpoint methodologies are incorporated into the actual setpoint. Because main turbine bypass flow can affect this setpoint nonconservatively (THERMAL POWER is derived from turbine first stage pressure), the main turbine

45

(continued)

during an in-service calibration

BASES

8

3-7

if performing the calibration using actual turbine first stage pressure

SURVEILLANCE REQUIREMENTS

SR 3.3.1.1.1 (continued)

7-45

3

bypass valves must remain closed at THERMAL POWER \geq 80% RTP to ensure that the calibration remains valid.

If any bypass channel's setpoint is nonconservative (i.e., the Functions are bypassed at \geq 80% RTP, either due to open main turbine bypass valve(s) or other reasons), then the affected Turbine Stop Valve-Closure and Turbine Control Valve Fast Closure, Trip Oil Pressure-Low Functions are considered inoperable. Alternatively, the bypass channel can be placed in the conservative condition (nonbypass). If placed in the nonbypass condition, this SR is met and the channel is considered OPERABLE.

92 days 7

The Frequency of ~~18 months~~ is based on engineering judgment and reliability of the components.

move to page B 3.3-31 as indicated

SR 3.3.1.1.1

This SR ensures that the individual channel response times are less than or equal to the maximum values assumed in the accident analysis. This test may be performed in one measurement or in overlapping segments, with verification that all components are tested. The RPS RESPONSE TIME acceptance criteria are included in Reference 10.

(Note 1)

As noted, neutron detectors are excluded from RPS RESPONSE TIME testing because the principles of detector operation virtually ensure an instantaneous response time.

RPS RESPONSE TIME tests are conducted on a 24 month STAGGERED TEST BASIS. Note 2 requires STAGGERED TEST BASIS Frequency to be determined based on 4 channels per trip system, in lieu of the 8 channels specified in Table 3.3.1.1-1 for the MSIV Closure Function. This Frequency is based on the logic interrelationships of the various channels required to produce an RPS scram signal. The 24 month Frequency is consistent with the typical industry refueling cycle and is based upon plant operating experience, which shows that random failures of instrumentation components causing serious response time degradation, but not channel failure, are infrequent occurrences.

Table B 3.3.1/1-1 (page 1 of 1)*
RPS Instrumentation Sensor Diversity

Initiation Events	Scram Sensors for Initiating Events						
	RPV Variables			Anticipatory			Fuel
	(a)	(b)	(c)	(d)	(e)	(f)	(g)
MSIV Closure	x		x			x	x
Turbine Trip (w/bypass)	x			x	x		x
Generator Trip (w/bypass)	x			x			x
Pressure Regulator Failure (primary pressure decrease) (MSIV closure trip)	x	x	x			x	x
Pressure Regulator Failure (primary pressure decrease) (Level B trip)	x				x		x
Pressure Regulator Failure (primary pressure increase)	x						x
Feedwater Controller Failure (high reactor water level)	x	x			x		x
Feedwater Controller Failure (low reactor water level)	x		x			x	
Loss of Condenser Vacuum	x				x	x	x
Loss of AC Power (loss of transformer)	x		x		x	x	
Loss of AC Power (loss of grid connections)	x		x	x	x	x	x

- (a) Reactor Vessel Steam Dome Pressure—High
- (b) Reactor Vessel Water Level—High, Level 8
- (c) Reactor Vessel Water Level—Low, Level 3
- (d) Turbine Control Valve Fast Closure
- (e) Turbine Stop Valve—Closure
- (f) Main Steam Isolation Valve—Closure
- (g) Average Power Range Monitor Neutron Flux—High

* This table for illustration purposes only.

JUSTIFICATION FOR DEVIATIONS FROM NUREG-1433, REVISION 1
ITS BASES: 3.3.1.1 - RPS INSTRUMENTATION

1. Typographical/grammatical error corrected.
2. Editorial change made for enhanced clarity or to be consistent with similar statements in other places in the Bases.
3. Changes have been made (additions, deletions, and/or changes to the NUREG) to reflect the plant specific methodology, nomenclature, number, reference, system description, or analysis description.
4. The brackets have been removed and the proper plant specific information/value has been provided.
5. This Table has been deleted since it provides generic and not plant specific types of information. The information in the Table could be misleading as to which plant specific analyses take credit for these channels to perform a function during accident and transient scenarios.
6. Changes have been made to more closely reflect the Specification requirements.
7. Changes have been made to reflect those changes made to the Specification. The following requirements have been renumbered, where applicable, to reflect the changes.
8. The words have been modified to state that opening the bypass valves may affect this Function. If the bypass valves are open above 45% RTP, but the Function is still enforcing the scram (i.e., it is not bypassed), there is no reason to declare the Function inoperable. If the Function is bypassed above 45% RTP due to an open bypass valve, then the Function would be inoperable. The proposed words state that an open bypass valve could affect this Function. The words in the Bases for proposed SR 3.3.1.1.13 (ISTS SR 3.3.1.1.16) have been modified to state that the bypass valves must remain closed during the calibration if using actual turbine first stage pressure. At other times, the bypass valves can be open (and the bypass valves are periodically opened to perform SRs) as long as the Function is not inadvertently bypassed.
9. This Reviewer's Note has been deleted. This information is for the NRC reviewer to be keyed in to what is needed to meet this requirement. This is not meant to be retained in the final version of the plant specific submittal.

B 3.3 INSTRUMENTATION

B 3.3.1.2 Source Range Monitor (SRM) Instrumentation

BASES

BACKGROUND

not fully
withdrawn

The SRMs provide the operator with information relative to the neutron flux level at very low flux levels in the core. As such, the SRM indication is used by the operator to monitor the approach to criticality and determine when criticality is achieved. The SRMs are ~~maintained fully inserted~~ until the count rate is greater than a minimum allowed count rate (a control rod block is set at this condition). After SRM to intermediate range monitor (IRM) overlap is demonstrated (as required by SR 3.3.1.1.6), the SRMs are normally fully withdrawn from the core.

1
2
TSTF-264
changes not
adopted

The SRM subsystem of the Neutron Monitoring System (NMS) consists of four channels. Each of the SRM channels can be bypassed, but only one at any given time, by the operation of a bypass switch. Each channel includes one detector that can be physically positioned in the core. Each detector assembly consists of a miniature fission chamber with associated cabling, signal conditioning equipment, and electronics associated with the various SRM functions. The signal conditioning equipment converts the current pulses from the fission chamber to analog DC currents that correspond to the count rate. Each channel also includes indication, alarm, and control rod blocks. However, this LCO specifies OPERABILITY requirements only for the monitoring and indication functions of the SRMs.

During refueling, shutdown, and low power operations, the primary indication of neutron flux levels is provided by the SRMs or special movable detectors connected to the normal SRM circuits. The SRMs provide monitoring of reactivity changes during fuel or control rod movement and give the control room operator early indication of unexpected subcritical multiplication that could be indicative of an approach to criticality.

APPLICABLE SAFETY ANALYSES

Prevention and mitigation of prompt reactivity excursions during refueling and low power operation is provided by LCO 3.9.1, "Refueling Equipment Interlocks"; LCO 3.1.1, "SHUTDOWN MARGIN (SDM)"; LCO 3.3.1.1, "Reactor Protection

(continued)

BASES

APPLICABLE
SAFETY ANALYSES
(continued)

System (RPS) Instrumentation"; IRM Neutron Flux—High and Average Power Range Monitor (APRM) Neutron Flux—High, Setdown Functions; and LCO 3.3.2.1, "Control Rod Block Instrumentation."

I

U

The SRMs have no safety function and are not assumed to function during any FSAR design basis accident or transient analysis. However, the SRMs provide the only on scale monitoring of neutron flux levels during startup and refueling. Therefore, they are being retained in Technical Specifications.

LCO

During startup in MODE 2, three of the four SRM channels are required to be OPERABLE to monitor the reactor flux level prior to and during control rod withdrawal, subcritical multiplication and reactor criticality, and neutron flux level and reactor period until the flux level is sufficient to maintain the IRM on Range 3 or above. All but one of the channels are required in order to provide a representation of the overall core response during those periods when reactivity changes are occurring throughout the core.

In MODES 3 and 4, with the reactor shut down, two SRM channels provide redundant monitoring of flux levels in the core.

normal changes in

S

In MODE 5, during a spiral offload or reload, an SRM outside the fueled region will no longer be required to be OPERABLE, since it is not capable of monitoring neutron flux in the fueled region of the core. Thus, CORE ALTERATIONS are allowed in a quadrant with no OPERABLE SRM in an adjacent quadrant provided the Table 3.3.1.2-1, footnote (b), requirement that the bundles being spiral reloaded or spiral offloaded are all in a single fueled region containing at least one OPERABLE SRM is met. Spiral reloading and offloading encompass reloading or offloading a cell on the edge of a continuous fueled region (the cell can be reloaded or offloaded in any sequence).

In nonspiral routine operations, two SRMs are required to be OPERABLE to provide redundant monitoring of reactivity

(continued)

BASES

LCO
(continued)

changes occurring in the reactor core. Because of the local nature of reactivity changes during refueling, adequate coverage is provided by requiring one SRM to be OPERABLE in the quadrant of the reactor core where CORE ALTERATIONS are being performed, and the other SRM to be OPERABLE in an adjacent quadrant containing fuel. These requirements ensure that the reactivity of the core will be continuously monitored during CORE ALTERATIONS.

Special movable detectors, according to footnote (c) of Table 3.3.1.2-1, may be used during CORE ALTERATIONS in place of the normal SRM nuclear detectors. These special detectors must be connected to the normal SRM circuits in the NMS, such that the applicable neutron flux indication can be generated. These special detectors provide more flexibility in monitoring reactivity changes during fuel loading, since they can be positioned anywhere within the core during refueling. They must still meet the location requirements of SR 3.3.1.2.02 and all other required SRs for SRMs.

1
In addition, in MODE 5, the required SRMs must be inserted to the normal operating level and be providing continuous visual indication in the control room.

2
in MODE 5

For an SRM channel to be considered OPERABLE, it must be providing neutron flux monitoring indication.

3

APPLICABILITY

The SRMs are required to be OPERABLE in MODES 2, 3, 4, and 5 prior to the IRMs being on scale on Range 3 to provide for neutron monitoring. In MODE 1, the APRMs provide adequate monitoring of reactivity changes in the core; therefore, the SRMs are not required. In MODE 2, with IRMs on Range 3 or above, the IRMs provide adequate monitoring and the SRMs are not required.

4
and MODES

ACTIONS

A.1 and B.1

In MODE 2, with the IRMs on Range 2 or below, SRMs provide the means of monitoring core reactivity and criticality. With any number of the required SRMs inoperable, the ability to monitor neutron flux is degraded. Therefore, a limited time is allowed to restore the inoperable channels to OPERABLE status.

(continued)

BASES

ACTIONS

A.1 and B.1 (continued)

Provided at least one SRM remains OPERABLE, Required Action A.1 allows 4 hours to restore the required SRMs to OPERABLE status. This time is reasonable because there is adequate capability remaining to monitor the core, there is limited risk of an event during this time, and there is sufficient time to take corrective actions to restore the required SRMs to OPERABLE status or to establish alternate IRM monitoring capability. During this time, control rod withdrawal and power increase is not precluded by this Required Action. Having the ability to monitor the core with at least one SRM, proceeding to IRM Range 3 or greater (with overlap required by SR 3.3.1.1.6), and thereby exiting the Applicability of this LCO, is acceptable for ensuring adequate core monitoring and allowing continued operation.

2
TSF-264
Changes not
adopted

With three required SRMs inoperable, Required Action B.1 allows no positive changes in reactivity (control rod withdrawal must be immediately suspended) due to inability to monitor the changes. Required Action A.1 still applies and allows 4 hours to restore monitoring capability prior to requiring control rod insertion. This allowance is based on the limited risk of an event during this time, provided that no control rod withdrawals are allowed, and the desire to concentrate efforts on repair, rather than to immediately shut down, with no SRMs OPERABLE.

C.1

with the IRMs on Range 2 or below

4

In MODE 2, if the required number of SRMs is not restored to OPERABLE status within the allowed Completion Time, the reactor shall be placed in MODE 3. With all control rods fully inserted, the core is in its least reactive state with the most margin to criticality. The allowed Completion Time of 12 hours is reasonable, based on operating experience, to reach MODE 3 from full power conditions in an orderly manner and without challenging plant systems.

D.1 and D.2

With one or more required SRMs inoperable in MODE 3 or 4, the neutron flux monitoring capability is degraded or nonexistent. The requirement to fully insert all insertable

(continued)

BASES

ACTIONS

D.1 and D.2 (continued)

control rods ensures that the reactor will be at its minimum reactivity level while no neutron monitoring capability is available. Placing the reactor mode switch in the shutdown position prevents subsequent control rod withdrawal by maintaining a control rod block. The allowed Completion Time of 1 hour is sufficient to accomplish the Required Action, and takes into account the low probability of an event requiring the SRM occurring during this interval.

E.1 and E.2

With one or more required SRM inoperable in MODE 5, the ability to detect local reactivity changes in the core during refueling is degraded. CORE ALTERATIONS must be immediately suspended and action must be immediately initiated to insert all insertable control rods in core cells containing one or more fuel assemblies. Suspending CORE ALTERATIONS prevents the two most probable causes of reactivity changes, fuel loading and control rod withdrawal, from occurring. Inserting all insertable control rods ensures that the reactor will be at its minimum reactivity given that fuel is present in the core. Suspension of CORE ALTERATIONS shall not preclude completion of the movement of a component to a safe, conservative position.

Action (once required to be initiated) to insert control rods must continue until all insertable rods in core cells containing one or more fuel assemblies are inserted.

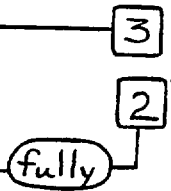

SURVEILLANCE REQUIREMENTS

As noted at the beginning of the SRs,

5

The SRs for each SRM Applicable MODE or other specified conditions are found in the SRs column of Table 3.3.1.2-1.

SR 3.3.1.2.1 and SR 3.3.1.2.3

Performance of the CHANNEL CHECK ensures that a gross failure of instrumentation has not occurred. A CHANNEL CHECK is normally a comparison of the parameter indicated on one channel to a similar parameter on another channel. It is based on the assumption that instrument channels monitoring the same parameter should read approximately the

(continued)

BASES

SURVEILLANCE
REQUIREMENTS

SR 3.3.1.2.1 and SR 3.3.1.2.3 (continued)

same value. Significant deviations between the instrument channels could be an indication of excessive instrument drift in one of the channels or something even more serious. A CHANNEL CHECK will detect gross channel failure; thus, it is key to verifying the instrumentation continues to operate properly between each CHANNEL CALIBRATION.

Agreement criteria are determined by the plant staff based on a combination of the channel instrument uncertainties, including indication and readability. If a channel is outside the criteria, it may be an indication that the instrument has drifted outside its limit.

The Frequency of once every 12 hours for SR 3.3.1.2.1 is based on operating experience that demonstrates channel failure is rare. While in MODES 3 and 4, reactivity changes are not expected; therefore, the 12 hour Frequency is relaxed to 24 hours for SR 3.3.1.2.3. The CHANNEL CHECK supplements less formal, but more frequent, checks of channels during normal operational use of the displays associated with the channels required by the LCO.

SR 3.3.1.2.2

To provide adequate coverage of potential reactivity changes in the core, one SRM is required to be OPERABLE in the quadrant where CORE ALTERATIONS are being performed, and the other OPERABLE SRM must be in an adjacent quadrant containing fuel. Note 1 states that the SR is required to be met only during CORE ALTERATIONS. It is not required to be met at other times in MODE 5 since core reactivity changes are not occurring. This Surveillance consists of a review of plant logs to ensure that SRMs required to be OPERABLE for given CORE ALTERATIONS are, in fact, OPERABLE. In the event that only one SRM is required to be OPERABLE, per Table 3.3.1.2-1, footnote (b), only the a. portion of this SR is required. Note 2 clarifies that more than one of the three requirements can be met by the same OPERABLE SRM. The 12 hour Frequency is based upon operating experience and supplements operational controls over refueling activities that include steps to ensure that the SRMs required by the LCO are in the proper quadrant.

5
effectively

(continued)

BASES

SURVEILLANCE
REQUIREMENTS
(continued)

SR 3.3.1.2.4

1
with the detector full in

This Surveillance consists of a verification of the SRM instrument readout to ensure that the SRM reading is greater than a specified minimum count rate, which ensures that the detectors are indicating count rates indicative of neutron flux levels within the core. With few fuel assemblies loaded, the SRMs will not have a high enough count rate to satisfy the SR. Therefore, allowances are made for loading sufficient "source" material, in the form of irradiated fuel assemblies, to establish the minimum count rate.

To accomplish this, the SR is modified by a Note that states that the count rate is not required to be met on an SRM that has less than or equal to four fuel assemblies adjacent to the SRM and no other fuel assemblies are in the associated core quadrant. With four or less fuel assemblies loaded around each SRM and no other fuel assemblies in the associated core quadrant, even with a control rod withdrawn, the configuration will not be critical.

When movable detectors are being used, detector location must be selected such that each group of fuel assemblies is separated by at least two fuel cells from any other fuel assemblies

The Frequency is based upon channel redundancy and other information available in the control room, and ensures that the required channels are frequently monitored while core reactivity changes are occurring. When no reactivity changes are in progress, the Frequency is relaxed from 12 hours to 24 hours.

SR 3.3.1.2.5 and SR 3.3.1.2.6

Performance of a CHANNEL FUNCTIONAL TEST demonstrates the associated channel will function properly. SR 3.3.1.2.5 is required in MODE 5, and the 7 day Frequency ensures that the channels are OPERABLE while core reactivity changes could be in progress. This Frequency is reasonable, based on operating experience and on other Surveillances (such as a CHANNEL CHECK), that ensure proper functioning between CHANNEL FUNCTIONAL TESTS.

1
in MODES 3 and 4 and core reactivity changes are due only to control rod movement in MODE 2

SR 3.3.1.2.6 is required in MODE 2 with IRMs on Range 2 or below, and in MODES 3 and 4. Since core reactivity changes do not normally take place, the frequency ~~has been~~ extended from 7 days to 31 days. The 31 day Frequency is based on operating experience and on other Surveillances (such as

to be met 5 15

(continued)

BASES

SURVEILLANCE
REQUIREMENTS

SR 3.3.1.2.5 and SR 3.3.1.2.6 (continued)

CHANNEL CHECK) that ensure proper functioning between CHANNEL FUNCTIONAL TESTS.

Verification of the signal to noise ratio also ensures that the detectors are inserted to an acceptable operating level. In a fully withdrawn condition, the detectors are sufficiently removed from the fueled region of the core to essentially eliminate neutrons from reaching the detector. Any count rate obtained while the detectors are fully withdrawn is assumed to be "noise" only.

2
Insert
SR 3,3,1.2.5

The Note to ~~the Surveillance~~ allows the Surveillance to be delayed until entry into the specified condition of the Applicability (THERMAL POWER decreased to IRM Range 2 or below). The SR must be performed within 12 hours after IRMs are on Range 2 or below. The allowance to enter the Applicability with the 31 day Frequency not met is reasonable, based on the limited time of 12 hours allowed after entering the Applicability and the inability to perform the Surveillance while at higher power levels. Although the Surveillance could be performed while on IRM Range 3, the plant would not be expected to maintain steady state operation at this power level. In this event, the 12 hour Frequency is reasonable, based on the SRMs being otherwise verified to be OPERABLE (i.e., satisfactorily performing the CHANNEL CHECK) and the time required to perform the Surveillances.

SR 3.3.1.2.6
5

SR 3.3.1.2.7

2
24

Performance of a CHANNEL CALIBRATION at a Frequency of 18 months verifies the performance of the SRM detectors and associated circuitry. The Frequency considers the plant conditions required to perform the test, the ease of performing the test, and the likelihood of a change in the system or component status. The neutron detectors are excluded from the CHANNEL CALIBRATION because they cannot readily be adjusted. The detectors are fission chambers that are designed to have a relatively constant sensitivity over the range and with an accuracy specified for a fixed useful life.

5
(Note 1)

(continued)

2

Insert SR 3.3.1.2.5

With few fuel assemblies loaded, the SRMs will not have a high enough count rate to determine the signal to noise ratio. Therefore, allowances are made for loading sufficient "source" material, in the form of irradiated fuel assemblies, to establish the conditions necessary to determine the signal to noise ratio. To accomplish this, SR 3.3.1.2.5 is modified by a Note that states that the determination of signal to noise ratio is not required to be met on an SRM that has less than or equal to four fuel assemblies adjacent to the SRM and no other fuel assemblies are in the associated core quadrant. With four or less fuel assemblies loaded around each SRM and no other fuel assemblies in the associated quadrant, even with a control rod withdrawn the configuration will not be critical.

BASES

**SURVEILLANCE
REQUIREMENTS**

SR 3.3.1.2.7 (continued)

Note 2 to the Surveillance allows the Surveillance to be delayed until entry into the specified condition of the Applicability. The SR must be performed in MODE 2 within 12 hours of entering MODE 2 with IRMs on Range 2 or below. The allowance to enter the Applicability with the 18 month Frequency not met is reasonable, based on the limited time of 12 hours allowed after entering the Applicability and the inability to perform the Surveillance while at higher power levels. Although the Surveillance could be performed while on IRM Range 3, the plant would not be expected to maintain steady state operation at this power level. In this event, the 12 hour Frequency is reasonable, based on the SRMs being otherwise verified to be OPERABLE (i.e., satisfactorily performing the CHANNEL CHECK) and the time required to perform the Surveillances.

2

24

REFERENCES

None.

JUSTIFICATION FOR DEVIATIONS FROM NUREG-1433, REVISION 1
ITS BASES: 3.3.1.2 - SRM INSTRUMENTATION

1. Changes have been made (additions, deletions, and/or changes to the NUREG) to reflect the plant specific methodology, nomenclature, number, reference, system description, analysis description, or licensing basis description.
2. Changes have been made to reflect those changes made to the Specification. The following requirements have been renumbered, where applicable, to reflect the changes.
3. Typographical/grammatical error corrected.
4. Changes have been made to more closely reflect the Specification requirements.
5. Editorial change made for enhanced clarity or to be consistent with similar statements in other places in the Bases.

B 3.3 INSTRUMENTATION

B 3.3.2.1 Control Rod Block Instrumentation

BASES

BACKGROUND

Control rods provide the primary means for control of reactivity changes. Control rod block instrumentation includes channel sensors, logic circuitry, switches, and relays that are designed to ensure that specified fuel design limits are not exceeded for postulated transients and accidents. During high power operation, the rod block monitor (RBM) provides protection for control rod withdrawal error events. During low power operations, control rod blocks from the rod worth minimizer (RWM) enforce specific control rod sequences designed to mitigate the consequences of the control rod drop accident (CRDA). During shutdown conditions, control rod blocks from the Reactor Mode Switch—Shutdown Position Function ensure that all control rods remain inserted to prevent inadvertent criticalities.

The purpose of the RBM is to limit control rod withdrawal if localized neutron flux exceeds a predetermined setpoint during control rod manipulations. It is assumed to function to block further control rod withdrawal to preclude a MCPR Safety Limit (SL) violation. The RBM supplies a trip signal to the Reactor Manual Control System (RMCS) to appropriately inhibit control rod withdrawal during power operation above the ~~low power range~~ setpoint. The RBM has two channels, either of which can initiate a control rod block when the channel output exceeds the control rod block setpoint. One RBM channel inputs into one RMCS rod block circuit and the other RBM channel inputs into the second RMCS rod block circuit. The RBM channel signal is generated by averaging a set of local power range monitor (LPRM) signals at various core heights surrounding the control rod being withdrawn. A signal from one average power range monitor (APRM) channel assigned to each Reactor Protection System (RPS) trip system supplies a reference signal for the RBM channel in the same trip system. This reference signal is used to determine which RBM range setpoint (low, intermediate, or high) is enabled. If the APRM is indicating less than the low power range setpoint, the RBM is automatically bypassed. The RBM is also automatically bypassed if a peripheral control rod is selected (Ref. 1).

(Ref. 1)

1 When a non-peripheral control rod selected

30% RTP

1 Insert BKEND

(continued)

INSERT BKGRND

One RBM channel averages the signals from LPRM detectors at the A and C positions in the assigned LPRM assemblies, while the other RBM channel averages the signals from LPRM detectors at the B and D positions. Assignment of LPRM assemblies to be used in RBM averaging is controlled by the selection of control rods. The RBM is automatically bypassed and the output set to zero if a peripheral rod is selected or the APRM used to normalize the RBM reading is $< 30\%$ RTP. If any LPRM detector assigned to an RBM is bypassed, the computed average signal is automatically adjusted to compensate for the number of LPRM input signals. The minimum number of LPRM inputs required for each RBM channel to prevent an instrument inoperative alarm is four when using four LPRM assemblies, three when using three LPRM assemblies, and two when using two LPRM assemblies. Each RBM also receives a recirculation loop flow signal from the associated flow converter.

With no control rod selected, the RBM output is set to zero. However, when a control rod is selected, the gain of each RBM channel output is normalized to a reference APRM. The gain setting is held constant during the movement of that particular control rod to provide an indication of the change in the relative local power level. If the indicated power increases above the preset limit, a rod block will occur. In addition, to preclude rod movement with an inoperable RBM, a downscale trip and an inoperable trip are provided.

BASES

BACKGROUND
(continued)

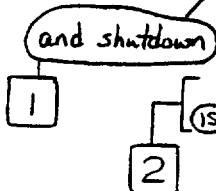

The purpose of the RWM is to control rod patterns during startup, such that only specified control rod sequences and relative positions are allowed over the operating range from all control rods inserted to 10% RTP. The sequences effectively limit the potential amount and rate of reactivity increase during a CRDA. Prescribed control rod sequences are stored in the RWM, which will initiate control rod withdrawal and insert blocks when the actual sequence deviates beyond allowances from the stored sequence. The RWM determines the actual sequence based on position indication for each control rod. The RWM also uses feedwater flow and steam flow signals to determine when the reactor power is above the preset power level at which the RWM is automatically bypassed (Ref. 2). The RWM is a single channel system that provides input into both RMCS rod block circuits.

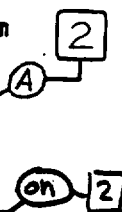

With the reactor mode switch in the shutdown position, a control rod withdrawal block is applied to all control rods to ensure that the shutdown condition is maintained. This function prevents inadvertent criticality as the result of a control rod withdrawal during MODE 3 or 4, or during MODE 5 when the reactor mode switch is required to be in the shutdown position. The reactor mode switch has two channels, each inputting into a separate RMCS rod block circuit. A rod block in either RMCS circuit will provide a control rod block to all control rods.

APPLICABLE SAFETY ANALYSES, LCO, and APPLICABILITY

1. Rod Block Monitor

The RBM is designed to prevent violation of the MCPR SL and the cladding 1% plastic strain fuel design limit that may result from a single control rod withdrawal error (RWE) event. The analytical methods and assumptions used in evaluating the RWE event are summarized in Reference 3. A statistical analysis of RWE events was performed to determine the RBM response for both channels for each event. From these responses, the fuel thermal performance as a function of RBM Allowable Value was determined. The Allowable Values are chosen as a function of power level. Based on the specified Allowable Values, operating limits are established.

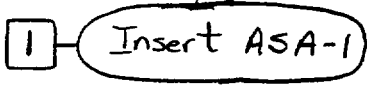

(continued)

1

INSERT ASA-1

The cycle-specific analysis considers the continuous withdrawal of the maximum worth control rod at its maximum drive speed from the reactor, which is operating at rated power with a control rod pattern that results in the core being placed on thermal design limits. The condition is analyzed to ensure that the results obtained are conservative; the approach also serves to demonstrate the functions of the RBM.

BASES

APPLICABLE
SAFETY ANALYSES,
LCO, and
APPLICABILITY

1. Rod Block Monitor (continued)

The RBM Function satisfies Criterion 3 of the NRC Policy Statement.

10CFR 50.36 (c)(2)(ii)

Two channels of the RBM are required to be OPERABLE, with their setpoints within the appropriate Allowable Value for the associated power/range, to ensure that no single instrument failure can preclude a rod block from this function. The actual setpoints are calibrated consistent with applicable setpoint methodology.

specified in the
CORE OPERATING
LIMITS REPORT

Nominal trip setpoints are specified in the setpoint calculations. The nominal setpoints are selected to ensure that the setpoints do not exceed the Allowable Values between successive CHANNEL CALIBRATIONS. Operation with a trip setpoint less conservative than the nominal trip setpoint, but within its Allowable Value, is acceptable. Trip setpoints are those predetermined values of output at which an action should take place. The setpoints are compared to the actual process parameter (e.g., reactor power), and when the measured output value of the process parameter exceeds the setpoint, the associated device (e.g., trip unit) changes state. The analytic limits are derived from the limiting values of the process parameters obtained from the safety analysis. The Allowable Values are derived from the analytic limits, corrected for calibration, process, and some of the instrument errors. The trip setpoints are then determined accounting for the remaining instrument errors (e.g., drift). The trip setpoints derived in this manner provide adequate protection because instrumentation uncertainties, process effects, calibration tolerances, instrument drift, and severe environment errors (for channels that must function in harsh environments as defined by 10 CFR 50.49) are accounted for.

and
Allowable
Values

and appropriately applied
for the instrumentation

The RBM is assumed to mitigate the consequences of an RWE event when operating $\geq 128\%$ RTP. Below this power level, the consequences of an RWE event will not exceed the MCPR SL and, therefore, the RBM is not required to be OPERABLE (Ref. 3). When operating $< 90\%$ RTP, analyses (Ref. 3) have shown that with an initial MCPR ≥ 1.70 , no RWE event will result in exceeding the MCPR SL. Also, the analyses demonstrate that when operating at $\geq 90\%$ RTP with MCPR ≥ 1.40 , no RWE event will result in exceeding the MCPR

and a non-peripheral
control rod is
selected

or if a peripheral control
rod is selected,
(continued)

BASES

APPLICABLE SAFETY ANALYSES, LCO, and APPLICABILITY

1. Rod Block Monitor (continued)

SL (Ref. 3). Therefore, under these conditions, the RBM is also not required to be OPERABLE.

2. Rod Worth Minimizer

1 (The RWM enforces the banked position withdrawal sequence (BPRS) to ensure that the initial conditions of the CRDA analysis are not violated. The analytical methods and assumptions used in evaluating the CRDA are summarized in References 4, 5, 6, and 7. The BPRS requires that control rods be moved in groups, with all control rods assigned to a specific group required to be within specified banked positions. Requirements that the control rod sequence is in compliance with the BPRS are specified in LCO 3.1.6, "Rod Pattern Control."

The RWM Function satisfies Criterion 3 of the NRC Policy Statement.

Since the RWM is a hardwired system designed to act as a backup to operator control of the rod sequences, only one channel of the RWM is available and required to be OPERABLE (Ref. 7). Special circumstances provided for in the Required Action of LCO 3.1.3, "Control Rod OPERABILITY," and LCO 3.1.6 may necessitate bypassing the RWM to allow continued operation with inoperable control rods, or to allow correction of a control rod pattern not in compliance with the BPRS. The RWM may be bypassed as required by these conditions, but then it must be considered inoperable and the Required Actions of this LCO followed.

Compliance with the BPRS, and therefore OPERABILITY of the RWM, is required in MODES 1 and 2 when THERMAL POWER is \leq 10% RTP. When THERMAL POWER is $>$ 10% RTP, there is no possible control rod configuration that results in a control rod worth that could exceed the 280 cal/gm fuel damage limit during a CRDA (Refs. 8 and 7). In MODES 3 and 4, all control rods are required to be inserted into the core; therefore, a CRDA cannot occur. In MODE 5, since only a single control rod can be withdrawn from a core cell containing fuel assemblies, adequate SDM ensures that the consequences of a CRDA are acceptable, since the reactor will be subcritical.

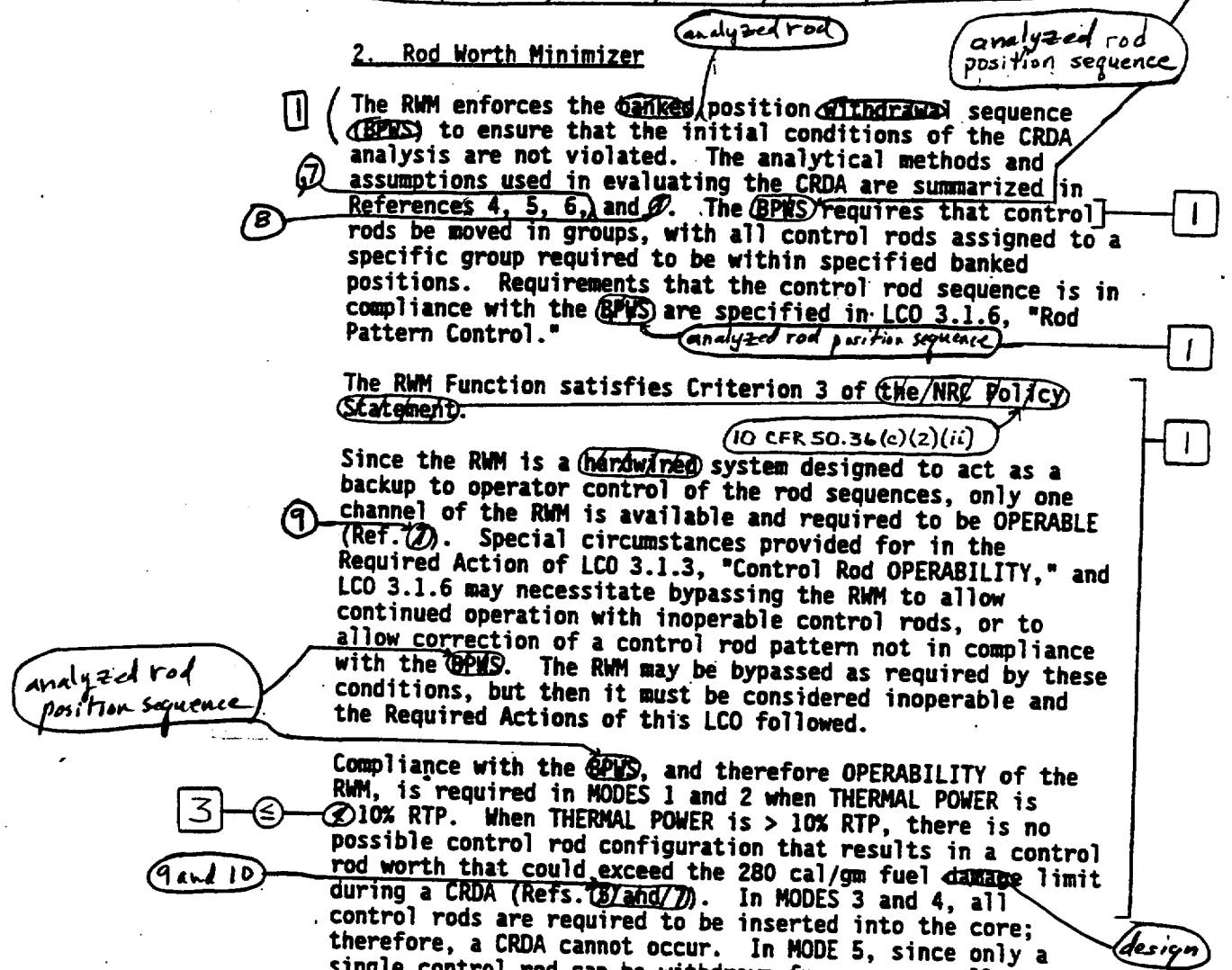

(continued)

BASES

APPLICABLE
SAFETY ANALYSES,
LCO, and
APPLICABILITY
(continued)

3. Reactor Mode Switch—Shutdown Position

During MODES 3 and 4, and during MODE 5 when the reactor mode switch is ~~required to be~~ in the shutdown position, the core is assumed to be subcritical; therefore, no positive reactivity insertion events are analyzed. The Reactor Mode Switch—Shutdown Position control rod withdrawal block ensures that the reactor remains subcritical by blocking control rod withdrawal, thereby preserving the assumptions of the safety analysis.

4

The Reactor Mode Switch—Shutdown Position Function satisfies Criterion 3 of the NRC Policy Statement.

1

10 CFR 50.36(c)(2)(ii)

Two channels are required to be OPERABLE to ensure that no single channel failure will preclude a rod block when required. There is no Allowable Value for this Function since the channels are mechanically actuated based solely on reactor mode switch position.

1

During shutdown conditions (MODE 3, 4, and 5), no positive reactivity insertion events are analyzed because assumptions are that control rod withdrawal blocks are provided to prevent criticality. Therefore, when the reactor mode switch is in the shutdown position, the control rod withdrawal block is required to be OPERABLE. During MODE 5 with the reactor mode switch in the refueling position, the refuel position one-rod-out interlock (LCO 3.9.2) provides the required control rod withdrawal blocks.

and and MODE

when the reactor mode switch is in the shutdown position

2

"Refuel Position One-Rod-Out Interlock"

5

ACTIONS

~~Reviewer's Note: Certain LCO Completion Times are based on approved topical reports. In order for the licensee to use the times, the licensee must justify the Completion Times as required by the staff Safety Evaluation Report (SER) for the topical report.~~

A.1

With one RBM channel inoperable, the remaining OPERABLE channel is adequate to perform the control rod block function; however, overall reliability is reduced because a single failure in the remaining OPERABLE channel can result in no control rod block capability for the RBM. For this

(continued)

BASES

ACTIONS

A.1 (continued)

reason, Required Action A.1 requires restoration of the inoperable channel to OPERABLE status. The Completion Time of 24 hours is based on the low probability of an event occurring coincident with a failure in the remaining OPERABLE channel.

B.1

If Required Action A.1 is not met and the associated Completion Time has expired, the inoperable channel must be placed in trip within 1 hour. If both RBM channels are inoperable, the RBM is not capable of performing its intended function; thus, one channel must also be placed in trip. This initiates a control rod withdrawal block, thereby ensuring that the RBM function is met.

The 1 hour Completion Time is intended to allow the operator time to evaluate and repair any discovered inoperabilities and is acceptable because it minimizes risk while allowing time for restoration or tripping of inoperable channels.

C.1, C.2.1.1, C.2.1.2, and C.2.2

With the RWM inoperable during a reactor startup, the operator is still capable of enforcing the prescribed control rod sequence. However, the overall reliability is reduced because a single operator error can result in violating the control rod sequence. Therefore, control rod movement must be immediately suspended except by scram. Alternatively, startup may continue if at least 12 control rods have already been withdrawn, or a reactor startup with an inoperable RWM was not performed in the last 12 months.

Required Actions C.2.1.1 and C.2.1.2 require verification of these conditions by review of plant logs and control room indications. Once Required Action C.2.1.1 or C.2.1.2 is satisfactorily completed, control rod withdrawal may proceed in accordance with the restrictions imposed by Required Action C.2.2. Required Action C.2.2 allows for the RWM Function to be performed manually and requires a double check of compliance with the prescribed rod sequence by a second licensed operator (Reactor Operator or Senior Reactor Operator) or other qualified member of the technical staff.

2
These requirements minimize the number of reactor startups initiated with the RWM inoperable.

4
during withdrawal of one or more of the first 12 control rods

4
calendar year (i.e., the current calendar year)

task 1

(continued)

2
(e.g., shift technical advisor or reactor engineer)

BASES

ACTIONS

C.1, C.2.1.1, C.2.1.2, and C.2.2 (continued)

The RWM may be bypassed under these conditions to allow continued operations. In addition, Required Actions of LCO 3.1.3 and LCO 3.1.6 may require bypassing the RWM, during which time the RWM must be considered inoperable with Condition C entered and its Required Actions taken.

D.1

With the RWM inoperable during a reactor shutdown, the operator is still capable of enforcing the prescribed control rod sequence. Required Action D.1 allows for the RWM Function to be performed manually and requires a double check of compliance with the prescribed rod sequence by a second licensed operator (Reactor Operator or Senior Reactor Operator) or other qualified member of the technical staff. The RWM may be bypassed under these conditions to allow the reactor shutdown to continue.

1
task

(e.g., shift technical advisor or reactor engineer) 2

E.1 and E.2

With one Reactor Mode Switch—Shutdown Position control rod withdrawal block channel inoperable, the remaining OPERABLE channel is adequate to perform the control rod withdrawal block function. However, since the Required Actions are consistent with the normal action of an OPERABLE Reactor Mode Switch—Shutdown Position Function (i.e., maintaining all control rods inserted), there is no distinction between having one or two channels inoperable.

In both cases (one or both channels inoperable), suspending all control rod withdrawal and initiating action to fully insert all insertable control rods in core cells containing one or more fuel assemblies will ensure that the core is subcritical with adequate SDM ensured by LCO 3.1.1. Control rods in core cells containing no fuel assemblies do not affect the reactivity of the core and are therefore not required to be inserted. Action must continue until all insertable control rods in core cells containing one or more fuel assemblies are fully inserted.

(continued)

BASES (continued)

SURVEILLANCE REQUIREMENTS

Reviewer's Note: Certain Frequencies are based on approved topical reports. In order for a licensee to use these Frequencies, the licensee must justify the Frequencies as required by the staff SER for the topical report.

5

As noted at the beginning of the SRs, the SRs for each Control Rod Block instrumentation Function are found in the SRs column of Table 3.3.2.1-1.

second

4

The Surveillances are modified by a Note to indicate that when an RBM channel is placed in an inoperable status solely for performance of required Surveillances, entry into associated Conditions and Required Actions may be delayed for up to 6 hours provided the associated Function maintains control rod block capability. Upon completion of the Surveillance, or expiration of the 6 hour allowance, the channel must be returned to OPERABLE status or the applicable Condition entered and Required Actions taken. This Note is based on the reliability analysis (Ref. 10) assumption of the average time required to perform channel Surveillance. That analysis demonstrated that the 6 hour testing allowance does not significantly reduce the probability that a control rod block will be initiated when necessary.

1

10

SR 3.3.2.1.1

A CHANNEL FUNCTIONAL TEST is performed for each RBM channel to ensure that the entire channel will perform the intended function. It includes the Reactor Manual Control Multiplexing System input.

1
"Relay Select Matrix"

Any setpoint adjustment shall be consistent with the assumptions of the current plant specific setpoint methodology. The Frequency of 92 days is based on reliability analyses (Ref. 12).

12

1

SR 3.3.2.1.2 and SR 3.3.2.1.3

A CHANNEL FUNCTIONAL TEST is performed for the RWM to ensure that the entire system will perform the intended function. The CHANNEL FUNCTIONAL TEST for the RWM is performed by attempting to withdraw a control rod not in compliance with

(continued)

BASES

1 SURVEILLANCE REQUIREMENTS

SR 3.3.2.1.2 and SR 3.3.2.1.3 (continued)

and by attempting to select a control rod not in compliance with the prescribed sequence and verifying a selection error occurs

the prescribed sequence and verifying a control rod block occurs. As noted in the SRs, SR 3.3.2.1.2 is not required to be performed until 1 hour after any control rod is withdrawn in MODE 2. ~~As noted, SR 3.3.2.1.3 is not required to be performed until 1 hour after THERMAL POWER is $\leq 10\%$ RTP in MODE 1. This allows entry into MODE 2 for SR 3.3.2.1.2, and entry into MODE 1 when THERMAL POWER is $\leq 10\%$ RTP for SR 3.3.2.1.3, to perform the required Surveillance, if the 92 day Frequency is not met per SR 3.0.2. The 1 hour allowance is based on operating experience and in consideration of providing a reasonable time in which to complete the SRs. The frequencies are based on reliability analysis (Ref. 8).~~

at $\leq 10\%$ RTP
in MODE 1

(and if entering during a shutdown, concurrent power reduction to $\leq 10\%$ RTP)

Insert from page B 3.3-53 and B 3.3-54

Insert SR 3.3.2.1.2

SR 3.3.2.1.1

Insert SR 3.3.2.1.5

The RBM setpoints are automatically varied as a function of power. Three Allowable Values are specified in Table 3.3.2.1-1, each within a specific power range. The power at which the control rod block Allowable Values automatically change are based on the APRM signal's input to each RBM channel. Below the minimum power setpoint, the RBM is automatically bypassed. These power Allowable Values must be verified periodically to be less than or equal to the specified values. If any power range setpoint is nonconservative, then the affected RBM channel is considered inoperable. Alternatively, the power range channel can be placed in the conservative condition (i.e., enabling the proper RBM setpoint). If placed in this condition, the SR is met and the RBM channel is not considered inoperable. As noted, neutron detectors are excluded from the Surveillance because they are passive devices, with minimal drift, and because of the difficulty of simulating a meaningful signal. Neutron detectors are adequately tested in SR 3.3.1.1.2 and SR 3.3.1.1.8. The 12 month Frequency is based on the actual trip setpoint methodology utilized for these channels.

to enable the RBM

bypass
APRM

SR 3.3.2.1.6

The RBM is automatically bypassed when power is above a specified value. The power level is determined from feedwater flow and steam flow signals. The automatic bypass

(continued)

1

INSERT SR 3.3.2.1.2

Operating experience has shown that these components usually pass the Surveillance when performed at the 92 day Frequency. Therefore, the Frequency was concluded to be acceptable from a reliability standpoint.

1

INSERT SR 3.3.2.1.5

is automatically bypassed when power is below a specified value or if a peripheral control rod is selected. The power level is determined from the APRM signals input to each RBM channel. The automatic bypass setpoint must be verified periodically to be < 30% RTP. In addition, it must also be verified that the RBM is not bypassed when a control rod that is not a peripheral control rod is selected (only one non-peripheral control rod is required to be verified).

BASES

SURVEILLANCE
REQUIREMENTS

SR 3.3.2.1.6 (continued)

setpoint must be verified periodically to be $\geq 10\%$ RTP. If the RWM low power setpoint is nonconservative, then the RWM is considered inoperable. Alternately, the low power setpoint channel can be placed in the conservative condition (nonbypass). If placed in the nonbypassed condition, the SR is met and the RWM is not considered inoperable. The Frequency is based on the trip setpoint methodology utilized for the low power setpoint channel.

SR 3.3.2.1.7

A CHANNEL FUNCTIONAL TEST is performed for the Reactor Mode Switch—Shutdown Position Function to ensure that the entire channel will perform the intended function. The CHANNEL FUNCTIONAL TEST for the Reactor Mode Switch—Shutdown Position Function is performed by attempting to withdraw any control rod with the reactor mode switch in the shutdown position and verifying a control rod block occurs.

As noted in the SR, the Surveillance is not required to be performed until 1 hour after the reactor mode switch is in the shutdown position, since testing of this interlock with the reactor mode switch in any other position cannot be performed without using jumpers, lifted leads, or movable links. This allows entry into MODES 3 and 4 if the 18 month Frequency is not met per SR 3.0.2. The 1 hour allowance is based on operating experience and in consideration of providing a reasonable time in which to complete the SRs.

The 18 month Frequency is based on the need to perform this Surveillance under the conditions that apply during a plant outage and the potential for an unplanned transient if the Surveillance were performed with the reactor at power. Operating experience has shown these components usually pass the Surveillance when performed at the 18 month Frequency.

SR 3.3.2.1.8

A CHANNEL CALIBRATION is a complete check of the instrument loop and the sensor. This test verifies the channel responds to the measured parameter within the necessary range and accuracy. CHANNEL CALIBRATION leaves the channel

(continued)

6
move to
page B 3.3-52
as indicated

BASES

SURVEILLANCE REQUIREMENTS

SR 3.3.2.1.0⁴ (continued)

adjusted to account for instrument drifts between successive calibrations consistent with the plant specific setpoint methodology.

As noted, neutron detectors are excluded from the CHANNEL CALIBRATION because they are passive devices, with minimal drift, and because of the difficulty of simulating a meaningful signal. Neutron detectors are adequately tested in SR 3.3.1.1.2 and SR 3.3.1.1.8.

The Frequency is based upon the assumption of ~~10 month~~^{92 day} calibration interval in the determination of the magnitude of equipment drift in the setpoint analysis.

move to page B 3.3-52 as indicated

SR 3.3.2.1.8

The RWM will only enforce the proper control rod sequence if the rod sequence is properly input into the RWM computer. This SR ensures that the proper sequence is loaded into the RWM so that it can perform its intended function. The Surveillance is performed once prior to declaring RWM OPERABLE following loading of sequence into RWM, since this is when rod sequence input errors are possible.

6
Insert SR 3.3.2.1.9

REFERENCES

1. FSAR, Section §7.6.2.2.5~~x~~ ^{1.5.3} 7
2. FSAR, Section §7.6.8.2.5~~x~~ ^{7.2} UFSAR Section 15.4.2.3~~o~~
3. ~~NEDE-30474-P, "Average Power Range Monitor, Rod Block Monitor, and Technical Specification Improvements (ARTS) Program for Edwin I. Hatch Nuclear Plants, December 1983.~~
4. ~~NEDE-2401X-P-A-9-US, "General Electrical Standard Application for Reload Fuel," Supplement for United States, Section S 2.7.3.1, September 1988.~~
5. "Modifications to the Requirements for Control Rod Drop Accident Mitigating Systems," BWR Owners' Group, July 1986.

11
Insert REF

(continued)

Insert from page B 3.3-55

6

Insert SR 3.3.2.1.9

SR 3.3.2.1.9

LCO 3.1.3 and LCO 3.1.6 may require individual control rods to be bypassed in the RWM to allow insertion of an inoperable control rod or correction of a control rod pattern not in compliance with the analyzed rod position sequence. With the control rods bypassed in the RWM, the RWM will not control the movement of these bypassed control rods. To ensure the proper bypassing and movement of these affected control rods, a second licensed operator (Reactor Operator or Senior Reactor Operator) or other task qualified member of the technical staff (e.g., shift technical advisor or reactor engineer) must verify the bypassing and position of these control rods. Compliance with this SR allows the RWM to be OPERABLE with these control rods bypassed.

11

Insert REF

4. UFSAR, Section 15.4.10.
5. XN-NF-80-19(P)(A), Volume 1, Supplement 2, Section 7.1 Exxon Nuclear Methodology for Boiling Water Reactor-Neutronics Methods for Design and Analysis, (as specified in Technical Specification 5.6.5).
6. NEDE-24011-P-A, "GE Standard Application for Reactor Fuel," (as specified in Technical Specification 5.6.5).
7. Letter to T.A. Pickens (BWROG) from G.C. Lainas (NRC), "Amendment 17 to General Electric Licensing Topical Report NEDE-24011-P-A," BWROG-8644, August 15, 1986.
8. NFSR-0091, Benchmark of CASMO/MICROBURN BWR Nuclear Design Methods, Commonwealth Edison Topical Report, (as specified in Technical Specification 5.6.5).

BASES

REFERENCES
(continued)

move to page
B 3.3-54
as indicated

6. NEDO-27231, "Banked Position Withdrawal Sequence,"
January 1977

9. NRC SER, "Acceptance of Referencing of Licensing
Topical Report NEDE-24011-P-A," "General Electric
Standard Application for Reactor Fuel, Revision 8,
Amendment 17," December 27, 1987.

12. NEDC-30851-P-A, "Technical Specification Improvement
Analysis for BWR Control Rod Block Instrumentation,"
October 1988.

11. GENE-770-06-14^{-A}, "Addendum to Bases for Changes to
Surveillance Test Intervals and Allowed Out-of-Service
Times for Selected Instrumentation Technical
Specifications," February 1991.
December 1992

1

JUSTIFICATION FOR DEVIATIONS FROM NUREG-1433, REVISION 1
ITS BASES: 3.3.2.1 - CONTROL ROD BLOCK INSTRUMENTATION

1. Changes have been made (additions, deletions, and/or changes to the NUREG) to reflect the plant specific methodology, nomenclature, number, reference, system description, analysis description, or licensing basis description.
2. Editorial change made for enhanced clarity or to be consistent with similar statements in other places in the Bases.
3. Typographical/grammatical error corrected.
4. Changes have been made to more closely reflect the Specification requirements.
5. This Reviewer's Note has been deleted. This information is for the NRC reviewer to be keyed in to what is needed to meet this requirement. This is not meant to be retained in the final version of the plant specific submittal.
6. Changes have been made to reflect those changes made to the Specification.
7. The brackets have been removed and the proper plant specific information/value has been provided.

Feedwater and Main Turbine High Water Level Trip Instrumentation
B 3.3.2.2

System 1

B 3.3 INSTRUMENTATION

B 3.3.2.2 Feedwater and Main Turbine High Water Level Trip Instrumentation

BASES

System 1

BACKGROUND

The Feedwater and Main Turbine High Water Level Trip Instrumentation is designed to detect a potential failure of the Feedwater Level Control System that causes excessive feedwater flow. 2

With excessive feedwater flow, the water level in the reactor vessel rises toward the high water level Level B reference point, causing the trip of the feedwater pump turbines and the main turbine. 3

differential pressure indicating switches 1

Reactor Vessel Water Level—High Level B signals are provided by level sensors that sense the difference between the pressure due to a constant column of water (reference leg) and the pressure due to the actual water level in the reactor vessel (variable leg). Three channels of Reactor Vessel Water Level—High Level B instrumentation are provided as input to a two-out-of-three initiation logic that trips the feedwater pump turbines and the main turbine. The channels include electronic equipment (e.g., trip units) that compares measured input signals with pre-established setpoints. When the setpoint is exceeded, the channel output relay actuates, which then outputs a main feedwater and turbine trip signal to the trip logic. 3

Three

pump

A trip of the feedwater pump turbines limits further increase in reactor vessel water level by limiting further addition of feedwater to the reactor vessel. A trip of the main turbine and closure of the stop valves protects the turbine from damage due to water entering the turbine. 3

2

System 1

feedwater pump and main 3

APPLICABLE SAFETY ANALYSES

The Feedwater and Main Turbine High Water Level Trip Instrumentation is assumed to be capable of providing a turbine trip in the design basis transient analysis for a feedwater controller failure, maximum demand event (Ref. 1). The Level B trip indirectly initiates a reactor scram from the main turbine trip (above 30% RTP) and trips the feedwater pumps, thereby terminating the event. The reactor scram mitigates the reduction in MCPR. 3

high level

3

45 3

(continued)

System 1

Feedwater and Main Turbine High Water Level Trip Instrumentation B 3.3.2.2

BASES

System 1

APPLICABLE SAFETY ANALYSES (continued)

Feedwater and Main Turbine High Water Level Trip Instrumentation satisfies Criterion 3 of ~~the NRC Policy Statement~~ } 2

10 CFR 50.36 (e)(2)(ii) } 3

Two 1

LCO

1 The LCO requires ~~three~~ channels of the Reactor Vessel Water Level-High Level instrumentation to be OPERABLE to ensure that no single instrument failure will prevent the feedwater pump, ~~cuplines~~ and main turbine ~~trip~~ on a valid ~~level~~ signal. Two of the ~~three~~ channels are needed to provide trip signals in order for the feedwater and main turbine trips to occur. Each channel must have its setpoint set within the specified Allowable Value of SR 3.3.2.2.3. The Allowable Value is set to ensure that the thermal limits are not exceeded during the event. The actual setpoint is calibrated to be consistent with the applicable setpoint methodology assumptions. Nominal trip setpoints are specified in the setpoint calculations. The nominal setpoints are selected to ensure that the setpoints do not exceed the Allowable Value between successive CHANNEL CALIBRATIONS. Operation with a trip setpoint less conservative than the nominal trip setpoint, but within its Allowable Value, is acceptable.

5
3
high level
3

trip
3
pump

Trip setpoints are those predetermined values of output at which an action should take place. The setpoints are compared to the actual process parameter (e.g., reactor vessel water level), and when the measured output value of the process parameter exceeds the setpoint, the associated device (e.g., trip unit) changes state. The analytic limits are derived from the limiting values of the process parameters obtained from the safety analysis. ~~The Allowable Values are derived from the analytic limits, corrected for calibration, process, and some of the instrument errors.~~ A channel is inoperable if its actual trip setpoint is not within its required Allowable Value. ~~The trip setpoints are then determined accounting for the remaining instrument errors (e.g., drift). The trip setpoints derived in this manner provide adequate protection because instrumentation uncertainties, process effects, calibration tolerances, instrument drift, and severe environment errors (for channels that must function in harsh environments as defined by 10 CFR 50.49) are accounted for.~~

3
Insert LCO

(continued)

3

Insert LCO

The trip setpoints are determined from the analytic limits, corrected for defined process, calibration, and instrument errors. The Allowable Values are then determined, based on the trip setpoint values, by accounting for the calibration based errors. These calibration based errors are limited to reference accuracy, instrument drift, errors associated with measurement and test equipment, and calibration tolerance of loop components. The trip setpoints and Allowable Values determined in this manner provide adequate protection because instrument uncertainties, process effects, calibration tolerances, instrument drift, and severe environment errors (for channels that must function in harsh environments as defined by 10 CFR 50.49) are accounted for and appropriately applied for the instrumentation.

Feedwater and Main Turbine High Water Level Trip Instrumentation
B 3.3.2.2

BASES (continued)

APPLICABILITY

3
LCO 3.2.3, "LINEAR HEAT GENERATION RATE," and LCO 3.2.4, "Average Power Range Monitor (APRM) Gain and Setpoint"

1
system
2
The feedwater and main turbine high water level trip instrumentation is required to be OPERABLE at $\geq 25\%$ RTP to ensure that the fuel cladding integrity Safety Limit and the cladding 1% plastic strain limit are not violated during the feedwater controller failure, maximum demand event. As discussed in the Bases for LCO 3.2.1, "Average Plant Linear Heat Generation Rate (APLHGR)," and LCO 3.2.2, "MINIMUM CRITICAL POWER RATIO (MCPR)," sufficient margin to these limits exists below 25% RTP; therefore, these requirements are only necessary when operating at or above this power level.

ACTIONS

1
A Note has been provided to modify the ACTIONS related to feedwater and main turbine high water level trip instrumentation channels. Section 1.3, Completion Times, specifies that once a Condition has been entered, subsequent divisions subsystems, components, or variables expressed in the Condition, discovered to be inoperable or not within limits, will not result in separate entry into the Condition. Section 1.3 also specifies that Required Actions of the Condition continue to apply for each additional failure, with Completion Times based on initial entry into the Condition. However, the Required Actions for inoperable feedwater and main turbine high water level trip instrumentation channels provide appropriate compensatory measures for separate inoperable channels. As such, a Note has been provided that allows separate Condition entry for each inoperable feedwater and main turbine high water level trip instrumentation channel.

A.1

1
With one channel inoperable, the remaining two OPERABLE channels can provide the required trip signal. However, overall instrumentation reliability is reduced because a single failure in one of the remaining channels concurrent with feedwater controller failure, maximum demand event, may result in the instrumentation not being able to perform its intended function. Therefore, continued operation is only allowed for a limited time with one channel inoperable. If the inoperable channel cannot be restored to OPERABLE status within the Completion Time, the channel must be placed in the tripped condition per Required Action A.1. Placing the

(continued)

Feedwater and Main Turbine High Water Level Trip Instrumentation
B 3.3.2.2

System 1

BASES

ACTIONS

A.1 (continued)

inoperable channel in trip would conservatively compensate for the inoperability, restore capability to accommodate a single failure, and allow operation to continue with no further restrictions. Alternately, if it is not desired to place the channel in trip (e.g., as in the case where placing the inoperable channel in trip would result in a feedwater or main turbine trip), Condition C must be entered and its Required Action taken.

The Completion Time of 7 days is based on the low probability of the event occurring coincident with a single failure in a remaining OPERABLE channel.

1
A

A.1

one

System 1

With ~~two~~ or more channels inoperable, the feedwater and main turbine high water level trip instrumentation cannot perform its design function (feedwater and main turbine high water level trip capability is not maintained). Therefore, continued operation is only permitted for a 2 hour period, during which feedwater and main turbine high water level trip capability must be restored. The trip capability is considered maintained when sufficient channels are OPERABLE or in trip such that the feedwater and main turbine high water level trip logic will generate a trip signal on a valid signal. This requires two channels to each be OPERABLE or in trip. If the required channels cannot be restored to OPERABLE status or placed in trip, Condition B must be entered and its Required Action taken.

2
System

2

B

System

The 2 hour Completion Time is sufficient for the operator to take corrective action, and takes into account the likelihood of an event requiring actuation of feedwater and main turbine high water level trip instrumentation occurring during this period. It is also consistent with the 2 hour Completion Time provided in LCO 3.2.2 for Required Action A.1, since this instrumentation's purpose is to preclude a MCPR violation.

2

(continued)

System 1

Feedwater and Main Turbine High Water Level Trip Instrumentation

B 3.3.2.2

BASES

and B.2 1

ACTIONS (continued)

1

Alternatively, if a channel is inoperable solely due to an inoperable feedwater pump breaker, the affected feedwater pump breaker may be removed from service since this performs the intended function of the instrumentation.

2

With the required channels not restored to OPERABLE status or placed in trip, THERMAL POWER must be reduced to < 25% RTP within 4 hours. As discussed in the Applicability section of the Bases, operation below 25% RTP results in sufficient margin to the required limits, and the feedwater and main turbine high water level trip instrumentation is not required to protect fuel integrity during the feedwater controller failure, maximum demand event. The allowed Completion Time of 4 hours is based on operating experience to reduce THERMAL POWER to < 25% RTP from full power conditions in an orderly manner and without challenging plant systems.

System 2

SURVEILLANCE REQUIREMENTS

6

Reviewer's Note: Certain Frequencies are based on approved topical reports. In order for a licensee to use these Frequencies the licensee must justify the Frequencies as required by the Staff Safety Evaluation Report (SER) for the topical report.

1

2

The Surveillances are modified by a Note to indicate that when a channel is placed in an inoperable status solely for performance of required Surveillances, entry into associated Conditions and Required Actions may be delayed for up to 6 hours provided the associated function maintains feedwater and main turbine high water level trip capability. Upon completion of the Surveillance, or expiration of the 6 hour allowance, the channel must be returned to OPERABLE status or the applicable Condition entered and Required Actions taken. This Note is based on the reliability analysis (Ref. 2) assumption that 6 hours is the average time required to perform channel Surveillance. That analysis demonstrated that the 6 hour testing allowance does not significantly reduce the probability that the feedwater pump turbines and main turbine will trip when necessary.

1

SR 3.3.2.2.1

Performance of the CHANNEL CHECK once every 24 hours ensures that a gross failure of instrumentation has not occurred. A CHANNEL CHECK is normally a comparison of the parameter

(continued)

BASES

**SURVEILLANCE
REQUIREMENTS**

SR 3.3.2.2.1 (continued)

indicated on one channel to a similar parameter on other channels. It is based on the assumption that instrument channels monitoring the same parameter should read approximately the same value. Significant deviations between instrument channels could be an indication of excessive instrument drift in one of the channels, or something even more serious. A CHANNEL CHECK will detect gross channel failure; thus, it is key to verifying the instrumentation continues to operate properly between each CHANNEL CALIBRATION.

Agreement criteria are determined by the plant staff based on a combination of the channel instrument uncertainties, including indication and readability. If a channel is outside the criteria, it may be an indication that the instrument has drifted outside its limits.

The Frequency is based on operating experience that demonstrates channel failure is rare. The CHANNEL CHECK supplements less formal, but more frequent, checks of channel status during normal operational use of the displays associated with the channels required by the LCO.

SR 3.3.2.2.2 2

A CHANNEL FUNCTIONAL TEST is performed on each required channel to ensure that the ~~entire~~ channel will perform the intended function. Any setpoint adjustment shall be consistent with the assumptions of the current plant specific setpoint methodology.

The Frequency of 92 days is based on ~~reliability analysis~~
(Ref/2).

operating experience 1

SR 3.3.2.2.3 2 1

CHANNEL CALIBRATION is a complete check of the instrument loop and the sensor. This test verifies the channel responds to the measured parameter within the necessary range and accuracy. CHANNEL CALIBRATION leaves the channel adjusted to account for instrument drifts between successive

(continued)

System

Feedwater and Main Turbine High Water Level Trip Instrumentation B 3.3.2.2

BASES

SURVEILLANCE REQUIREMENTS

SR 3.3.2.2.3 (continued)

calibrations consistent with the plant specific setpoint methodology.

The Frequency is based upon the assumption of an ~~18 month~~ 92 day calibration interval in the determination of the magnitude of equipment drift in the setpoint analysis.

SR 3.3.2.2.4

The LOGIC SYSTEM FUNCTIONAL TEST demonstrates the OPERABILITY of the required trip logic for a specific channel. The system functional test of the feedwater and main turbine valves is included as part of this Surveillance and overlaps the LOGIC SYSTEM FUNCTIONAL TEST to provide complete testing of the assumed safety function. Therefore if a valve is incapable of operating, the associated instrumentation would also be inoperable. The 24 month Frequency is based on the need to perform this Surveillance under the conditions that apply during a plant outage and the potential for an unplanned transient if the Surveillance were performed with the reactor at power. Operating experience has shown that these components usually pass the Surveillance when performed at the 24 month Frequency.

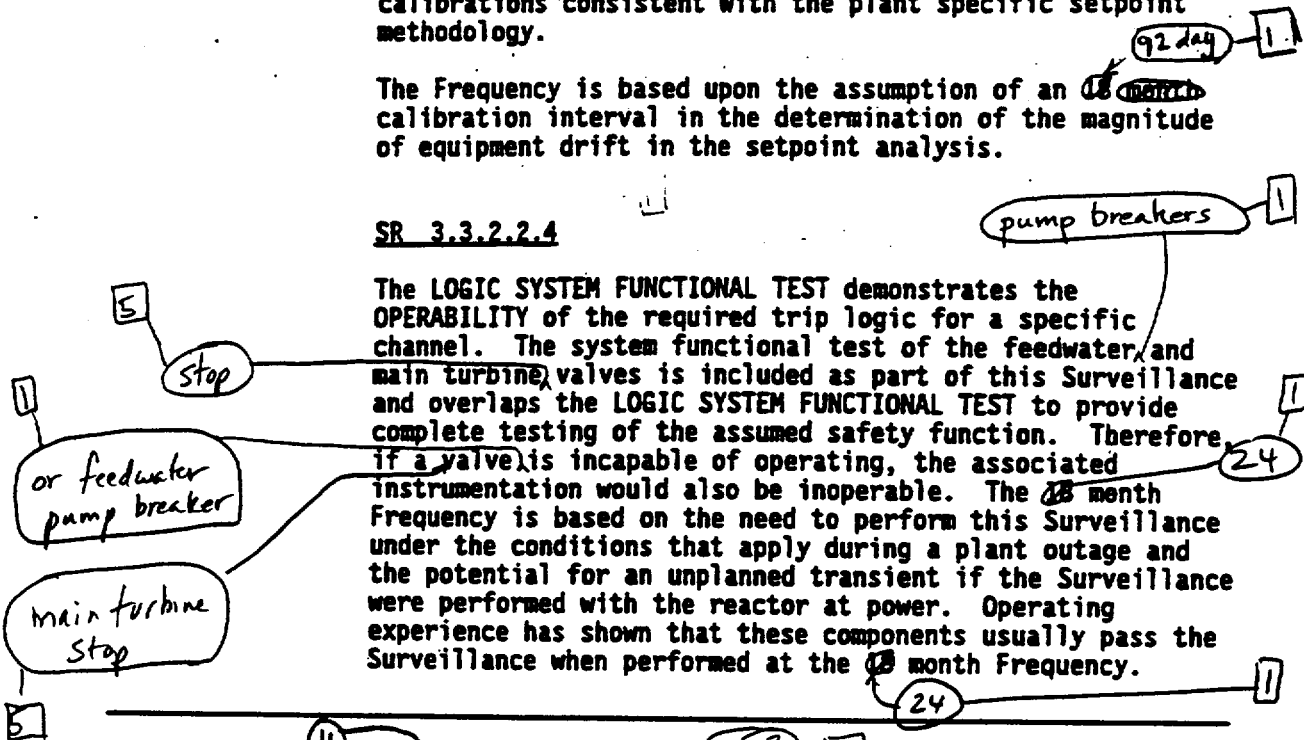

REFERENCES

1. FSAR, Section X15.1X.
2. GENE-770-06-1, "Bases for Changes to Surveillance Test Intervals and Allowed Out-Of-Service Times for Selected Instrumentation Technical Specifications," February 1991.

JUSTIFICATION FOR DEVIATIONS FROM NUREG-1433, REVISION 1
ITS BASES: 3.3.2.2 - FEEDWATER SYSTEM AND MAIN TURBINE HIGH
WATER LEVEL TRIP INSTRUMENTATION

1. Changes have been made to reflect those changes made to the Specification.
2. Editorial change made to be consistent with similar statements in other places in the Bases.
3. Changes have been made (additions, deletions, and/or changes to the NUREG) to reflect the plant specific methodology, nomenclature, number, reference, system description, analysis description, or licensing basis description.
4. Not used.
5. Changes have been made to more closely reflect the Specification requirements.
6. This Reviewer's Note has been deleted. This information is for the NRC reviewer to be keyed in to what is needed to meet this requirement. This is not meant to be retained in the final version of the plant specific submittal.
7. The brackets have been removed and the proper plant specific information/value has been provided.

B 3.3 INSTRUMENTATION

B 3.3.3.1 Post Accident Monitoring (PAM) Instrumentation

BASES

1
, in the control room,

BACKGROUND

The primary purpose of the PAM instrumentation is to display plant variables that provide information required by the control room operators during accident situations. This information provides the necessary support for the operator to take the manual actions for which no automatic control is provided and that are required for safety systems to accomplish their safety functions for Design Basis Events. The instruments that monitor these variables are designated as Type A, Category I, and non-Type A, Category I, in accordance with Regulatory Guide 1.97 (Ref. 1).

The OPERABILITY of the accident monitoring instrumentation ensures that there is sufficient information available on selected plant parameters to monitor and assess plant status and behavior following an accident. This capability is consistent with the recommendations of Reference 1.

APPLICABLE SAFETY ANALYSES

The PAM instrumentation LCO ensures the OPERABILITY of Regulatory Guide 1.97, Type A variables so that the control room operating staff can:

- Perform the diagnosis specified in the Emergency Operating Procedures (EOPs). These variables are restricted to preplanned actions for the primary success path of Design Basis Accidents (DBAs), (e.g., loss of coolant accident (LOCA)), and
- Take the specified, preplanned, manually controlled actions for which no automatic control is provided, which are required for safety systems to accomplish their safety function.

The PAM instrumentation LCO also ensures OPERABILITY of Category I, non-Type A, variables so that the control room operating staff can:

- Determine whether systems important to safety are performing their intended functions;

(continued)

BASES

**APPLICABLE
SAFETY ANALYSES
(continued)**

- Determine the potential for causing a gross breach of the barriers to radioactivity release;
- Determine whether a gross breach of a barrier has occurred; and
- Initiate action necessary to protect the public and for an estimate of the magnitude of any impending threat.

The plant specific Regulatory Guide 1.97 Analysis (Ref. 2) documents the process that identified Type A and Category I, non-Type A, variables.

Accident monitoring instrumentation that satisfies the definition of Type A in Regulatory Guide 1.97 meets Criterion 3 of the NRC Policy Statement. Category I, non-Type A, instrumentation is retained in Technical Specifications (TS) because they are intended to assist operators in minimizing the consequences of accidents. Therefore, these Category I variables are important for reducing public risk.

1
10CFR 50.36(e)(2)(ii)

LCO

LCO 3.3.3.1 requires two OPERABLE channels for all but one Function to ensure that no single failure prevents the operators from being presented with the information necessary to determine the status of the plant and to bring the plant to, and maintain it in, a safe condition following ~~that~~ accident, providing

2

an

Furthermore, provision of two channels allows a CHANNEL CHECK during the post accident phase to confirm the validity of displayed information. [More than two channels may be required at some plants if the Regulatory Guide 1.97 analysis determined that failure of one accident monitoring channel results in information ambiguity (that is, the redundant displays disagree) that could lead operators to defeat or to fail to accomplish a required safety function.]

3

4

The exception to the two channel requirement is primary containment isolation valve (PCIV) position. In this case, the important information is the status of the primary containment penetrations. The LCO requires one position indicator for each active PCIV. This is sufficient to

(e.g., automatic)

3

(continued)

BASES

LCO
(continued)

redundantly verify the isolation status of each isolable penetration either via indicated status of the active valve and prior knowledge of passive valve or via system boundary status. If a normally active PCIV is known to be closed and deactivated, position indication is not needed to determine status. Therefore, the position indication for valves (in this state) is not required to be OPERABLE.

closed and deactivated

The following list is a discussion of the specified instrument functions listed in Table 3.3.3.1-1 in the accompanying LCO. These discussions are intended as examples of what should be provided for each function when the plant specific list is prepared.

The output from one of these channels is recorded on an independent pen recorder and the other channel output is directed to an indicator. The

1. Reactor (Steam Dome) Pressure

Reactor (steam dome) pressure is a Category I variable provided to support monitoring of Reactor Coolant System (RCS) integrity and to verify operation of the Emergency Core Cooling Systems (ECCS). Two independent pressure transmitters with a range of 0 psig to 1500 psig monitor pressure. Wide range recorders are the primary indications used by the operator during an accident. Therefore, the PAM Specification deals specifically with this portion of the instrument channel.

and provide indication to the control room

2. Reactor Vessel Water Level

Reactor vessel water level is a Category I variable provided to support monitoring of core cooling and to verify operation of the ECCS. (The wide range water level) channels provide the PAM Reactor Vessel Water Level Function. The wide range water level channels measure from 17 inches below the dryer skirt down to a point just below the bottom of the active fuel. Wide range water level is measured by two independent differential pressure transmitters. The output from these channels is recorded on (two) independent pen recorders, which is the primary indication used by the operator during an accident. Therefore, the PAM Specification deals specifically with this portion of the instrument channel.

Two different range

approximately 202 inches above the top of active fuel to approximately 198 inches below the top of active fuel while the narrow range channels measure from approximately 82 inches above the top of active fuel to approximately 202 inches above the top of active fuel

one of and the other output is directed to an indicator. Narrow range level is measured by two independent differential pressure transmitters. The output from these channels is directed to two independent indicators.

(continued)

All changes are 1 unless indicated otherwise

BASES

LCO

2. Reactor Vessel Water Level (continued)

reactor vessel
The wide range water level instruments are uncompensated for variation in reactor water density and are calibrated to be most accurate at operational pressure and temperature.

The wide range instruments are calibrated to be accurate at post-DBA LOCA pressure and temperature. The narrow range instruments are calibrated to be accurate at the normal operating pressure and temperature.

3. Suppression Pool Water Level

Suppression pool water level is a Category I variable provided to detect a breach in the reactor coolant pressure boundary (RCPB). This variable is also used to verify and provide long term surveillance of ECCS function. The wide range suppression pool water level measurement provides the operator with sufficient information to assess the status of both the RCPB and the water supply to the ECCS. The wide range water level indicators monitor the suppression pool water level from the center line of the ECCS suction lines to the top of the pool. Two wide range suppression pool water level signals are transmitted from separate differential pressure transmitters, and are continuously recorded on two recorders in the control room. These recorders are the primary indication used by the operator during an accident. Therefore, the PAM Specification deals specifically with this portion of the instrument channel.

to two control room indicators
displayed instruments

4. Drywell Pressure

Drywell pressure is a Category I variable provided to detect breach of the RCPB and to verify ECCS functions that operate to maintain RCS integrity. Two wide range drywell pressure signals are transmitted from separate pressure transmitters and are continuously recorded and displayed on two control room recorders. These recorders are the primary indication used by the operator during an accident. Therefore, the PAM Specification deals specifically with this portion of the instrument channel.

The wide range drywell pressure

The wide range instruments measure from -5 psig to 250 psig while the narrow range instruments monitor between -5 psig and 70 psig.

and indicators

Insert LCD 4

and indicators

channels provide the PAM Drywell Pressure Function.

5. Primary Containment Area Radiation (High Range)

Primary/containment/area radiation (high range) is provided to monitor the potential of significant radiation releases and to provide release assessment for use by operators in determining the need to invoke site emergency plans. (For

Drywell

a Category I variable

(continued)

The drywell pressure channels also satisfy the monitoring requirement for suppression chamber (torus) pressure since the suppression chamber - to - drywell vacuum breakers ensure the suppression chamber pressure is maintained within 0.5 psig of the drywell pressure.

0

INSERT LCO 4

Two narrow range drywell pressure signals are transmitted from separate transmitters and are continuously displayed on independent indicators in the control room.

BASES

LCO

Drywell

5. Primary Containment Area Radiation (High Range)
(continued)

6

Insert LCO 5

this plant, primary containment area radiation (High range) PAM instrumentation consists of the following:]

5

6. Drywell Sump Level

Drywell sump level is a Category I variable provided for verification of ECCS functions that operate to maintain RCS integrity. [For this plant, the drywell sump level PAM instrumentation consists of the following:]

TSTF-295

Penetration Flow Path

7. Drywell Drain Sump Level

Drywell drain sump level is a Category I variable provided to detect breach of the RCPB and for verification and long term surveillance of ECCS functions that operate to maintain RCS integrity. [For this plant, the drywell drain sump level PAM instrumentation consists of the following.]

6

6

a Category I variable

8. Primary Containment Isolation Valve (PCIV) Position

1

(excluding check valves)

PCIV position is provided for verification of containment integrity. In the case of PCIV position, the important information is the isolation status of the containment penetration. The LCO requires one channel of valve position indication in the control room to be OPERABLE for each active PCIV in a containment penetration flow path, i.e., two total channels of PCIV position indication for a penetration flow path with two active valves. For containment penetrations with only one active PCIV having control room indication, Note (b) requires a single channel of valve position indication to be OPERABLE. This is sufficient to redundantly verify the isolation status of each isolable penetration via indicated status of the active valve, as applicable, and prior knowledge of passive valve or system boundary status. If a penetration flow path is isolated, position indication for the PCIV(s) in the associated penetration flow path is not needed to determine status. Therefore, the position indication for valves in an isolated penetration flow path is not required to be OPERABLE.

requiring post-accident valve position indication

TSTF-295

(continued)

BWR/4 STS

B 3.3-67

Rev 1, 04/07/95

Each penetration is treated separately and each penetration flow path is considered a separate function. Therefore, separate condition entry is allowed for each inoperable penetration flow path.

5

INSERT LCO 5

Two redundant radiation sensors are located in capped drywell penetrations and have a range from 10^0 R/hr to 10^8 R/hr. These radiation monitors display on recorders located in the control room. Two radiation monitors/recorders are required to be OPERABLE (one per division). Therefore, the PAM Specification deals specifically with this portion of the instrument channel.

BASES

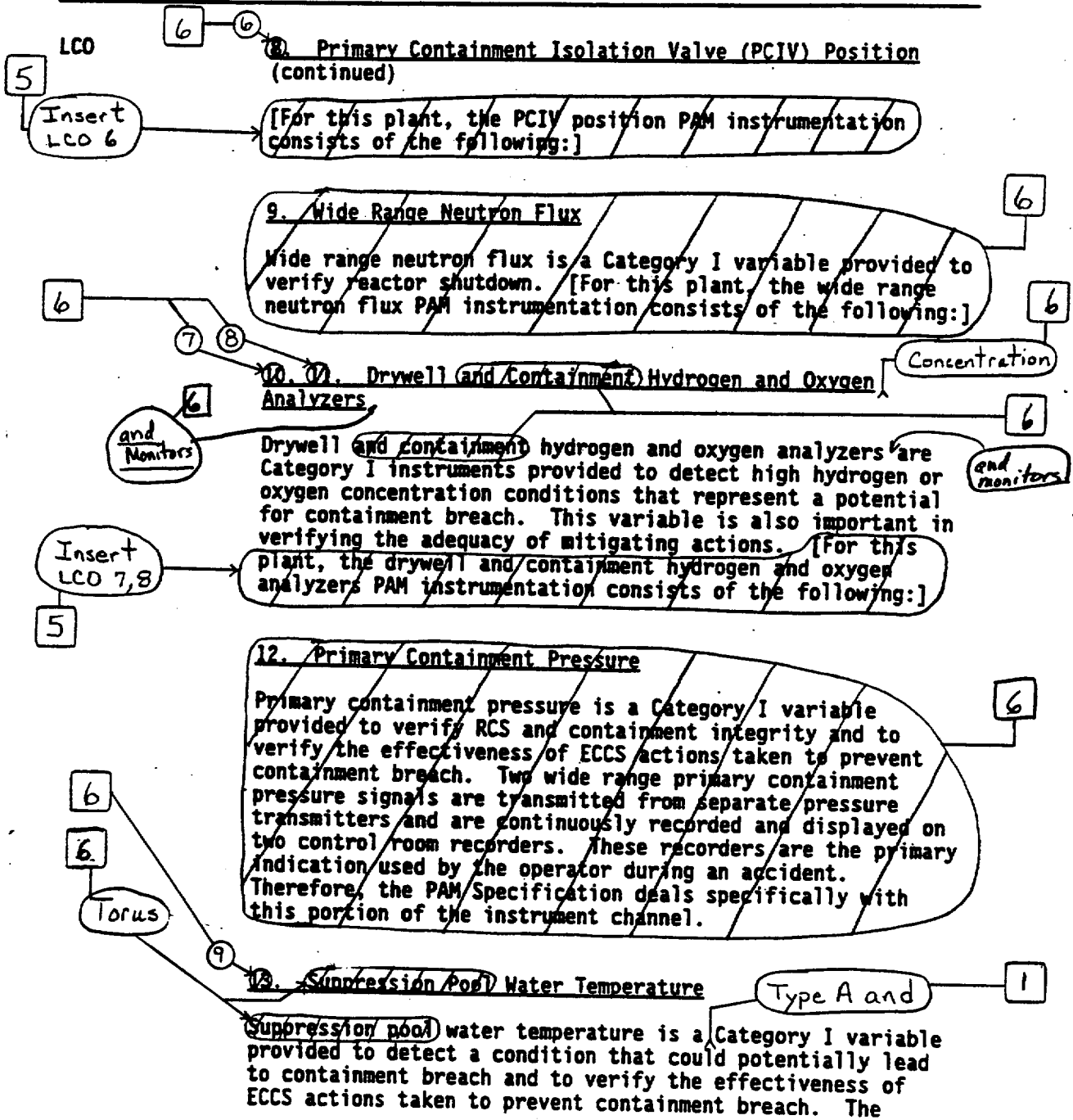

(continued)

5

INSERT LCO 6

The indication for each PCIV is provided at the valve controls in the control room. Each indication consists of green and red indicator lights that illuminate to indicate whether the PCIV is fully open, fully closed, or in a mid-position. Therefore, the PAM Specification deals specifically with this portion of the instrumentation channel.

5

INSERT LCO 7, 8

Hydrogen and oxygen concentrations are each measured by two independent analyzers and are monitored in the control room. The drywell hydrogen and oxygen analyzer PAM instrumentation consists of two independent gas analyzer systems. Each gas analyzer system consists of a hydrogen analyzer and an oxygen analyzer. The analyzers are capable of determining hydrogen concentration in the range of 0% to 10% and oxygen concentration in the range of 0% to 10%. Each gas analyzer system must be capable of sampling the drywell. There are two independent recorders in the control room to display the results. Therefore, the PAM Specification deals specifically with this portion of the instrument channel.

All changes are [1] unless indicated otherwise

BASES

LCO [6] → [9] → [12] Suppression Pool Water Temperature (continued) Torus

torus → suppression pool water temperature instrumentation allows operators to detect trends in suppression pool water temperature in sufficient time to take action to prevent steam quenching vibrations in the suppression pool.

Sixteen → twenty-four temperature sensors are arranged in six groups of four independent and redundant channels, located such that there is a group of sensors within a 30 ft line of sight of each relief valve discharge location.

eight sensors in → are two

two → Thus, six groups of sensors are sufficient to monitor each relief valve discharge location. Each group of four sensors includes two sensors for normal suppression pool temperature monitoring and two sensors for PAM. The outputs for the PAM sensors are recorded on four independent recorders in the control room (channels A and C are redundant to channels B and D, respectively). All four of these recorders must be OPERABLE to furnish two channels of PAM indication for each of the relief valve discharge locations. These recorders are the primary indication used by the operator during an accident. Therefore, the PAM Specification deals specifically with this portion of the instrument channels.

two → The range of the torus water temperature channels is 0°F to 300°F

two → the bulk average temperature of the torus water

eight →

two →

Both → (one inner and one outer) located in each of the four quadrants to assure an accurate measurement of bulk water temperature is averaged to provide two bulk temperature inputs

APPLICABILITY

The PAM instrumentation LCO is applicable in MODES 1 and 2. These variables are related to the diagnosis and preplanned actions required to mitigate DBAs. The applicable DBAs are assumed to occur in MODES 1 and 2. In MODES 3, 4, and 5, plant conditions are such that the likelihood of an event that would require PAM instrumentation is extremely low; therefore, PAM instrumentation is not required to be OPERABLE in these MODES.

ACTIONS

Note 1 has been added to the ACTIONS to exclude the MODE change restriction of LCO 3.0.4. This exception allows entry into the applicable MODE while relying on the ACTIONS even though the ACTIONS may eventually require plant shutdown. This exception is acceptable due to the passive function of the instruments, the operator's ability to diagnose an accident using alternative instruments and methods, and the low probability of an event requiring these instruments.

TSTF-295

(continued)

Each suppression pool water temperature [relief valve discharge location] is treated separately and each [relief valve discharge location] is considered to be a separate function. Therefore, separate Condition entry is allowed for each operable [relief valve discharge location].

BASES

ACTIONS
(continued)

Note 2 has been provided to modify the ACTIONS related to PAM instrumentation channels. Section 1.3, Completion Times, specifies that once a Condition has been entered, subsequent divisions, subsystems, components, or variables expressed in the Condition discovered to be inoperable or not within limits, will not result in separate entry into the Condition. Section 1.3 also specifies that Required Actions of the Condition continue to apply for each additional failure, with Completion Times based on initial entry into the Condition. However, the Required Actions for inoperable PAM instrumentation channels provide appropriate compensatory measures for separate Functions. As such, a Note has been provided that allows separate Condition entry for each inoperable PAM Function.

A.1

When one or more Functions have one required channel that is inoperable, the required inoperable channel must be restored to OPERABLE status within 30 days. The 30 day Completion Time is based on operating experience and takes into account the remaining OPERABLE channels (or, in the case of a Function that has only one required channel, other non-Regulatory Guide 1.97 instrument channels to monitor the Function), the passive nature of the instrument (no critical automatic action is assumed to occur from these instruments), and the low probability of an event requiring PAM instrumentation during this interval.

or remaining isolation barrier (in the case of primary containment penetration with only one PCIV).

B.1

If a channel has not been restored to OPERABLE status in 30 days, this Required Action specifies initiation of action in accordance with Specification 5.6.8, which requires a written report to be submitted to the NRC. This report discusses the results of the root cause evaluation of the inoperability and identifies proposed restorative actions. This action is appropriate in lieu of a shutdown requirement, since alternative actions are identified before loss of functional capability, and given the likelihood of plant conditions that would require information provided by this instrumentation.

3 Required

another OPERABLE channel is monitoring the Function, an alternate method of monitoring is available

(continued)

BASES

ACTIONS
(continued)

C.1

When one or more Functions have two required channels that are inoperable (i.e., two channels inoperable in the same Function), one channel in the Function should be restored to OPERABLE status within 7 days. The Completion Time of 7 days is based on the relatively low probability of an event requiring PAM instrument operation and the availability of alternate means to obtain the required information. Continuous operation with two required channels inoperable in a Function is not acceptable because the alternate indications may not fully meet all performance qualification requirements applied to the PAM instrumentation. Therefore, requiring restoration of one inoperable channel of the Function limits the risk that the PAM Function will be in a degraded condition should an accident occur. Condition C is modified by a Note that excludes hydrogen monitor channels. Condition D provides appropriate Required Actions for two inoperable hydrogen monitor channels.

6

D.1

When two hydrogen monitor channels are inoperable, one hydrogen monitor channel must be restored to OPERABLE status within 72 hours. The 72 hour Completion Time is based on the low probability of the occurrence of a LOCA that would generate hydrogen in amounts capable of exceeding the flammability limit; the length of time after the event that operator action would be required to prevent hydrogen accumulation from exceeding this limit; and the availability of the hydrogen recombiners, the Hydrogen Purge System, and the Post Accident Sampling System.

6

6 - (D) -> D.1

This Required Action directs entry into the appropriate Condition referenced in Table 3.3.3.1-1. The applicable Condition referenced in the Table is Function dependent. Each time an inoperable channel has not met ~~any~~ Required Action of Condition C ~~or D, as applicable~~, and the associated Completion Time has expired, Condition ~~C~~ is entered for that channel and provides for transfer to the appropriate subsequent Condition.

3

the

(D)

6

(continued)

6

INSERT SR

The Surveillances are modified by a second Note to indicate that when a channel is placed in an inoperable status solely for performance of required Surveillances, entry into associated Conditions and Required Actions may be delayed for up to 6 hours, provided the other required channel in the associated Function is OPERABLE. Upon completion of the Surveillance, or expiration of the 6 hour allowance, the channel must be returned to OPERABLE status or the applicable Condition entered and Required Actions taken. The 6 hour testing allowance is acceptable since it does not significantly reduce the probability of properly monitoring post-accident parameters, when necessary.

□

INSERT SR 3.3.3.1.2

For Function 5, the CHANNEL CALIBRATION shall consist of an electronic calibration of the channel, excluding the detector, for range decades > 10 R/hour and a one point calibration check of the detector with an installed or portable gamma source for the range decade < 10 R/hour. For Function 6, the CHANNEL CALIBRATION shall consist of verifying that the position indication conforms to actual valve position.

JUSTIFICATION FOR DEVIATIONS FROM NUREG-1433, REVISION 1
ITS BASES: 3.3.3.1 - POST ACCIDENT MONITORING INSTRUMENTATION

1. Changes have been made (additions, deletions, and/or changes to the NUREG) to reflect the plant specific methodology, nomenclature, number, reference, system description, analysis description or licensing basis description.
2. Typographical/grammatical error corrected.
3. Editorial change made for enhanced clarity or to be consistent with similar statements in other places in the Bases.
4. This Reviewer's Note (or reviewer's type of note) has been deleted. This information is for the NRC reviewer to be keyed in to what is needed to meet this requirement. This is not meant to be retained in the final version of the plant specific submittal.
5. The brackets have been removed and the proper plant specific information/value has been provided.
6. Changes have been made to reflect those changes made to the Specification. The following requirements have been renumbered, where applicable, to reflect the changes.
7. TSTF-295 revisions associated with Suppression Pool Water Temperature (NUREG-1433, ISTS Table 3.3.3.1-1, Function 13) are not incorporated in proposed Bases of Quad Cities 1 and 2 ITS 3.3.3.1. This difference is consistent with current licensing requirements for the Torus Water Temperature. All temperature sensors associated with a channel (irrespective of sensor location) are required to be OPERABLE for the channel to be OPERABLE.

B 3.3 INSTRUMENTATION

B 3.3.3.2 Remote Shutdown System

BASES

BACKGROUND

The Remote Shutdown System provides the control room operator with sufficient instrumentation and controls to place and maintain the plant in a safe shutdown condition from a location other than the control room. This capability is necessary to protect against the possibility of the control room becoming inaccessible. A safe shutdown condition is defined as MODE 3. With the plant in MODE 3, the Reactor Core Isolation Cooling (RCIC) System, the safety/relief valves, and the Residual Heat Removal Shutdown Cooling System can be used to remove core decay heat and meet all safety requirements. The long term supply of water for the RCIC and the ability to operate shutdown cooling from outside the control room allow extended operation in MODE 3.

In the event that the control room becomes inaccessible, the operators can establish control at the remote shutdown panel and place and maintain the plant in MODE 3. Not all controls and necessary transfer switches are located at the remote shutdown panel. Some controls and transfer switches will have to be operated locally at the switchgear, motor control panels, or other local stations. The plant automatically reaches MODE 3 following a plant shutdown and can be maintained safely in MODE 3 for an extended period of time.

The OPERABILITY of the Remote Shutdown System control and instrumentation functions ensures that there is sufficient information available on selected plant parameters to place and maintain the plant in MODE 3 should the control room become inaccessible.

**APPLICABLE
SAFETY ANALYSES**

The Remote Shutdown System is required to provide equipment at appropriate locations outside the control room with a design capability to promptly shut down the reactor to MODE 3, including the necessary instrumentation and controls, to maintain the plant in a safe condition in MODE 3.

(continued)

BASES

**APPLICABLE
SAFETY ANALYSES
(continued)**

The criteria governing the design and the specific system requirements of the Remote Shutdown System are located in 10 CFR 50, Appendix A, GDC 19 (Ref. 1).

The Remote Shutdown System is considered an important contributor to reducing the risk of accidents; as such, it has been retained in the Technical Specifications (TS) as indicated in the NRC Policy Statement.

LCO

The Remote Shutdown System LCO provides the requirements for the OPERABILITY of the instrumentation and controls necessary to place and maintain the plant in MODE 3 from a location other than the control room. The instrumentation and controls typically required are listed in Table 3.3.3.2-1 in the accompanying LCO.

Reviewer's Note: For channels that fulfill GDC 19 requirements, the number of OPERABLE channels required depends upon the plant's licensing basis as described in the NRC plant specific Safety Evaluation Report (SER). Generally, two divisions are required to be OPERABLE. However, only one channel per given Function is required if the plant has justified such a design and the NRC SER has accepted the justification.

The controls, instrumentation, and transfer switches are those required for:

- Reactor pressure vessel (RPV) pressure control;
- Decay heat removal;
- RPV inventory control; and
- Safety support systems for the above functions, including service water, component cooling water, and onsite power, including the diesel generators.

The Remote Shutdown System is OPERABLE if all instrument and control channels needed to support the remote shutdown function are OPERABLE. In some cases, Table 3.3.3.2-1 may indicate that the required information or control capability is available from several alternate sources. In these cases, the Remote Shutdown System is OPERABLE as long as one

(continued)

BASES

LCO
(continued)

channel of any of the alternate information or control sources for each Function is OPERABLE.

The Remote Shutdown System instruments and control circuits covered by this LCO do not need to be energized to be considered OPERABLE. This LCO is intended to ensure that the instruments and control circuits will be OPERABLE if plant conditions require that the Remote Shutdown System be placed in operation.

APPLICABILITY

The Remote Shutdown System LCO is applicable in MODES 1 and 2. This is required so that the plant can be placed and maintained in MODE 3 for an extended period of time from a location other than the control room.

This LCO is not applicable in MODES 3, 4, and 5. In these MODES, the plant is already subcritical and in a condition of reduced Reactor Coolant System energy. Under these conditions, considerable time is available to restore necessary instrument control Functions if control room instruments or control becomes unavailable. Consequently, the TS do not require OPERABILITY in MODES 3, 4, and 5.

ACTIONS

A Note is included that excludes the MODE change restriction of LCO 3.0.4. This exception allows entry into an applicable MODE while relying on the ACTIONS even though the ACTIONS may eventually require a plant shutdown. This exception is acceptable due to the low probability of an event requiring this system.

Note 2 has been provided to modify the ACTIONS related to Remote Shutdown System Functions. Section 1.3, Completion Times, specifies that once a Condition has been entered, subsequent divisions, subsystems, components, or variables expressed in the Condition, discovered to be inoperable or not within limits, will not result in separate entry into the Condition. Section 1.3 also specifies that Required Actions of the Condition continue to apply for each additional failure, with Completion Times based on initial entry into the Condition. However, the Required Actions for inoperable Remote Shutdown System Functions provide appropriate compensatory measures for separate Functions.

(continued)

BASES

ACTIONS
(continued)

As such, a Note has been provided that allows separate Condition entry for each inoperable Remote Shutdown System Function.

A.1

Condition A addresses the situation where one or more required Functions of the Remote Shutdown System is inoperable. This includes any Function listed in Table 3.3.3.2-1, as well as the control and transfer switches.

The Required Action is to restore the Function (both divisions, if applicable) to OPERABLE status within 30 days. The Completion Time is based on operating experience and the low probability of an event that would require evacuation of the control room.

B.1

If the Required Action and associated Completion Time of Condition A are not met, the plant must be brought to a MODE in which the LCO does not apply. To achieve this status, the plant must be brought to at least MODE 3 within 12 hours. The allowed Completion Time is reasonable, based on operating experience, to reach the required MODE from full power conditions in an orderly manner and without challenging plant systems.

SURVEILLANCE
REQUIREMENTS

SR 3.3.3.2.1

Performance of the CHANNEL CHECK once every 31 days ensures that a gross failure of instrumentation has not occurred. A CHANNEL CHECK is normally a comparison of the parameter indicated on one channel to a similar parameter on other channels. It is based on the assumption that instrument channels monitoring the same parameter should read approximately the same value. Significant deviations between the instrument channels could be an indication of excessive instrument drift in one of the channels or something even more serious. A CHANNEL CHECK will detect gross channel failure; thus, it is key to verifying

(continued)

BASES

**SURVEILLANCE
REQUIREMENTS**

SR 3.3.3.2.1 (continued)

the instrumentation continues to operate properly between each CHANNEL CALIBRATION.

Agreement criteria are determined by the plant staff based on a combination of the channel instrument uncertainties, including indication and readability. If a channel is outside the criteria, it may be an indication that the sensor or the signal processing equipment has drifted outside its limit. As specified in the Surveillance, a CHANNEL CHECK is only required for those channels that are normally energized.

The Frequency is based upon plant operating experience that demonstrates channel failure is rare.

SR 3.3.3.2.2

SR 3.3.3.2.2 verifies each required Remote Shutdown System transfer switch and control circuit performs the intended function. This verification is performed from the remote shutdown panel and locally, as appropriate. Operation of the equipment from the remote shutdown panel is not necessary. The Surveillance can be satisfied by performance of a continuity check. This will ensure that if the control room becomes inaccessible, the plant can be placed and maintained in MODE 3 from the remote shutdown panel and the local control stations. However, this Surveillance is not required to be performed only during a plant outage. Operating experience demonstrates that Remote Shutdown System control channels usually pass the Surveillance when performed at the 18 month Frequency.

SR 3.3.3.2.3

CHANNEL CALIBRATION is a complete check of the instrument loop and the sensor. The test verifies the channel responds to measured parameter values with the necessary range and accuracy.

The 18 month Frequency is based upon operating experience and consistency with the typical industry refueling cycle.

(continued)

BASES (continued)

- REFERENCES**
1. 10 CFR 50, Appendix A, GDC 19.
-

JUSTIFICATION FOR DEVIATIONS FROM NUREG-1433, REVISION 1
ISTS BASES: 3.3.3.2 - REMOTE SHUTDOWN SYSTEM

1. This Bases has been deleted since the associated Specification has been deleted.

B 3.3 INSTRUMENTATION

B 3.3.4.1 End of Cycle Recirculation Pump Trip (EOC-RPT) Instrumentation

BASES

BACKGROUND

The EOC-RPT instrumentation initiates a recirculation pump trip (RPT) to reduce the peak reactor pressure and power resulting from turbine trip or generator load rejection transients to provide additional margin to core thermal MCPR Safety Limits (SLs).

The need for the additional negative reactivity in excess of that normally inserted on a scram reflects end of cycle reactivity considerations. Flux shapes at the end of cycle are such that the control rods may not be able to ensure that thermal limits are maintained by inserting sufficient negative reactivity during the first few feet of rod travel upon a scram caused by Turbine Control Valve (TCV) Fast Closure, Trip Oil Pressure—Low or Turbine Stop Valve (TSV)—Closure. The physical phenomenon involved is that the void reactivity feedback due to a pressurization transient can add positive reactivity at a faster rate than the control rods can add negative reactivity.

The EOC-RPT instrumentation, as shown in Reference 1, is composed of sensors that detect initiation of closure of the TSVs or fast closure of the TCVs, combined with relays, logic circuits, and fast acting circuit breakers that interrupt power from the recirculation pump motor generator (MG) set generators to each of the recirculation pump motors. The channels include electronic equipment (e.g., trip units) that compares measured input signals with pre-established setpoints. When the setpoint is exceeded, the channel output relay actuates, which then outputs an EOC-RPT signal to the trip logic. When the RPT breakers trip open, the recirculation pumps coast down under their own inertia. The EOC-RPT has two identical trip systems, either of which can actuate an RPT.

Each EOC-RPT trip system is a two-out-of-two logic for each function; thus, either two TSV—Closure or two TCV Fast Closure, Trip Oil Pressure—Low signals are required for a trip system to actuate. If either trip system actuates, both recirculation pumps will trip. There are two EOC-RPT breakers in series per recirculation pump. One trip system trips one of the two EOC-RPT breakers for each recirculation

(continued)

BASES

**BACKGROUND
(continued)**

pump, and the second trip system trips the other EOC-RPT breaker for each recirculation pump.

**APPLICABLE
SAFETY ANALYSES,
LCO, and
APPLICABILITY**

The TSV—Closure and the TCV Fast Closure, Trip Oil Pressure—Low Functions are designed to trip the recirculation pumps in the event of a turbine trip or generator load rejection to mitigate the neutron flux, heat flux, and pressurize transients, and to increase the margin to the MCPR SL. The analytical methods and assumptions used in evaluating the turbine trip and generator load rejection, as well as other safety analyses that ensure EOC-RPT, are summarized in References 2, 3, and 4.

To mitigate pressurization transient effects, the EOC-RPT must trip the recirculation pumps after initiation of closure movement of either the TSVs or the TCVs. The combined effects of this trip and a scram reduce fuel bundle power more rapidly than a scram alone, resulting in an increased margin to the MCPR SL. Alternatively, MCPR limits for an inoperable EOC-RPT, as specified in the COLR, are sufficient to mitigate pressurization transient effects. The EOC-RPT function is automatically disabled when turbine first stage pressure is < [40%] RTP.

EOC-RPT instrumentation satisfies Criterion 3 of the NRC Policy Statement.

The OPERABILITY of the EOC-RPT is dependent on the OPERABILITY of the individual instrumentation channel Functions. Each Function must have a required number of OPERABLE channels in each trip system, with their setpoints within the specified Allowable Value of SR 3.3.4.1.3. The actual setpoint is calibrated consistent with applicable setpoint methodology assumptions. Channel OPERABILITY also includes the associated EOC-RPT breakers. Each channel (including the associated EOC-RPT breakers) must also respond within its assumed response time.

Allowable Values are specified for each EOC-RPT Function specified in the LCO. Nominal trip setpoints are specified in the setpoint calculations. A channel is inoperable if its actual trip setpoint is not within its required Allowable Value. The nominal setpoints are selected to ensure that the setpoints do not exceed the Allowable Value

(continued)

BASES

**APPLICABLE
SAFETY ANALYSES,
LCO, and
APPLICABILITY
(continued)**

between successive CHANNEL CALIBRATIONS. Operation with a trip setpoint less conservative than the nominal trip setpoint, but within its Allowable Value, is acceptable. Each Allowable Value specified is more conservative than the analytical limit assumed in the transient and accident analysis in order to account for instrument uncertainties appropriate to the Function. Trip setpoints are those predetermined values of output at which an action should take place. The setpoints are compared to the actual process parameter (e.g., TSV position), and when the measured output value of the process parameter exceeds the setpoint, the associated device (e.g., trip unit) changes state. The analytic limits are derived from the limiting values of the process parameters obtained from the safety analysis. The Allowable Values are derived from the analytic limits, corrected for calibration process, and some of the instrument errors. The trip setpoints are then determined accounting for the remaining instrument errors (e.g., drift). The trip setpoints derived in this manner provide adequate protection because instrumentation uncertainties, process effects, calibration tolerances, instrument drift, and severe environment errors (for channels that must function in harsh environments as defined by 10 CFR 50.49) are accounted for.

The specific Applicable Safety Analysis, LCO, and Applicability discussions are listed below on a Function by Function basis.

Alternatively, since this instrumentation protects against a MCPR SL violation, with the instrumentation inoperable, modifications to the MCPR limits (LCO 3.2.2) may be applied to allow this LCO to be met. The MCPR penalty for the EOC-RPT inoperable condition is specified in the COLR.

Turbine Stop Valve—Closure

Closure of the TSVs and a main turbine trip result in the loss of a heat sink that produces reactor pressure, neutron flux, and heat flux transients that must be limited. Therefore, an RPT is initiated on TSV—Closure in anticipation of the transients that would result from closure of these valves. EOC-RPT decreases reactor power and aids the reactor scram in ensuring that the MCPR SL is not exceeded during the worst case transient.

(continued)

BASES

**APPLICABLE
SAFETY ANALYSES,
LCO, and
APPLICABILITY**

Turbine Stop Valve—Closure (continued)

Closure of the TSVs is determined by measuring the position of each valve. There are two separate position switches associated with each stop valve, the signal from each switch being assigned to a separate trip channel. The logic for the TSV—Closure Function is such that two or more TSVs must be closed to produce an EOC-RPT. This Function must be enabled at THERMAL POWER \geq 30% RTP. This is normally accomplished automatically by pressure transmitters sensing turbine first stage pressure; therefore, to consider this Function OPERABLE, the turbine bypass valves must remain shut at THERMAL POWER \geq 30% RTP. Four channels of TSV—Closure, with two channels in each trip system, are available and required to be OPERABLE to ensure that no single instrument failure will preclude an EOC-RPT from this Function on a valid signal. The TSV—Closure Allowable Value is selected to detect imminent TSV closure.

This protection is required, consistent with the safety analysis assumptions, whenever THERMAL POWER is \geq 30% RTP. Below 30% RTP, the Reactor Vessel Steam Dome Pressure—High and the Average Power Range Monitor (APRM) Fixed Neutron Flux—High Functions of the Reactor Protection System (RPS) are adequate to maintain the necessary safety margins.

Turbine Control Valve Fast Closure, Trip Oil Pressure—Low

Fast closure of the TCVs during a generator load rejection results in the loss of a heat sink that produces reactor pressure, neutron flux, and heat flux transients that must be limited. Therefore, an RPT is initiated on TCV Fast Closure, Trip Oil Pressure—Low in anticipation of the transients that would result from the closure of these valves. The EOC-RPT decreases reactor power and aids the reactor scram in ensuring that the MCPR SL is not exceeded during the worst case transient.

Fast closure of the TCVs is determined by measuring the electrohydraulic control fluid pressure at each control valve. There is one pressure transmitter associated with each control valve, and the signal from each transmitter is assigned to a separate trip channel. The logic for the TCV Fast Closure, Trip Oil Pressure—Low Function is such that two or more TCVs must be closed (pressure transmitter trips)

(continued)

BASES

**APPLICABLE
SAFETY ANALYSES,
LCO, and
APPLICABILITY**

Turbine Control Valve Fast Closure, Trip Oil Pressure—Low
(continued)

to produce an EOC-RPT. This Function must be enabled at THERMAL POWER \geq 30% RTP. This is normally accomplished automatically by pressure transmitters sensing turbine first stage pressure; therefore, to consider this Function OPERABLE, the turbine bypass valves must remain shut at THERMAL POWER \geq 30% RTP. Four channels of TCV Fast Closure, Trip Oil Pressure—Low, with two channels in each trip system, are available and required to be OPERABLE to ensure that no single instrument failure will preclude an EOC-RPT from this Function on a valid signal. The TCV Fast Closure, Trip Oil Pressure—Low Allowable Value is selected high enough to detect imminent TCV fast closure.

This protection is required consistent with the safety analysis whenever THERMAL POWER is $>$ 30% RTP. Below 30% RTP, the Reactor Vessel Steam Dome Pressure—High and the APRM Fixed Neutron Flux—High Functions of the RPS are adequate to maintain the necessary safety margins.

ACTIONS

Reviewer's Note: Certain LCO Completion Times are based on approved topical reports. In order for a licensee to use the times, the licensee must justify the Completion Times as required by the staff Safety Evaluation Report (SER) for the topical report.

A Note has been provided to modify the ACTIONS related to EOC-RPT instrumentation channels. Section 1.3, Completion Times, specifies that once a Condition has been entered, subsequent divisions, subsystems, components, or variables expressed in the Condition, discovered to be inoperable or not within limits, will not result in separate entry into the Condition. Section 1.3 also specifies that Required Actions of the Condition continue to apply for each additional failure, with Completion Times based on initial entry into the Condition. However, the Required Actions for inoperable EOC-RPT instrumentation channels provide appropriate compensatory measures for separate inoperable channels. As such, a Note has been provided that allows separate Condition entry for each inoperable EOC-RPT instrumentation channel.

(continued)

BASES

ACTIONS
(continued)

A.1

With one or more channels inoperable, but with EOC-RPT trip capability maintained (refer to Required Actions B.1 and B.2 Bases), the EOC-RPT System is capable of performing the intended function. However, the reliability and redundancy of the EOC-RPT instrumentation is reduced such that a single failure in the remaining trip system could result in the inability of the EOC-RPT System to perform the intended function. Therefore, only a limited time is allowed to restore compliance with the LCO. Because of the diversity of sensors available to provide trip signals, the low probability of extensive numbers of inoperabilities affecting all diverse functions, and the low probability of an event requiring the initiation of an EOC-RPT, 72 hours is provided to restore the inoperable channels (Required Action A.1) [or apply the EOC-RPT inoperable MCFR limit]. Alternately, the inoperable channels may be placed in trip (Required Action A.2) since this would conservatively compensate for the inoperability, restore capability to accommodate a single failure, and allow operation to continue. As noted, placing the channel in trip with no further restrictions is not allowed if the inoperable channel is the result of an inoperable breaker, since this may not adequately compensate for the inoperable breaker (e.g., the breaker may be inoperable such that it will not open). If it is not desired to place the channel in trip (e.g., as in the case where placing the inoperable channel in trip would result in an RPT, or if the inoperable channel is the result of an inoperable breaker), Condition C must be entered and its Required Actions taken.

B.1 and B.2

Required Actions B.1 and B.2 are intended to ensure that appropriate actions are taken if multiple, inoperable, untripped channels within the same Function result in the Function not maintaining EOC-RPT trip capability. A Function is considered to be maintaining EOC-RPT trip capability when sufficient channels are OPERABLE or in trip, such that the EOC-RPT System will generate a trip signal from the given Function on a valid signal and both recirculation pumps can be tripped. This requires two channels of the Function in the same trip system, to each be OPERABLE or in trip, and the associated EOC-RPT breakers to

(continued)

BASES

ACTIONS

B.1 and B.2 (continued)

be OPERABLE or in trip. Alternately, Required Action B.2 requires the MCPR limit for inoperable EOC-RPT, as specified in the COLR, to be applied. This also restores the margin to MCPR assumed in the safety analysis.

The 2 hour Completion Time is sufficient time for the operator to take corrective action, and takes into account the likelihood of an event requiring actuation of the EOC-RPT instrumentation during this period. It is also consistent with the 2 hour Completion Time provided in UCO 3.2.2 for Required Action A.1, since this instrumentation's purpose is to preclude a MCPR violation.

C.1 and C.2

With any Required Action and associated Completion Time not met, THERMAL POWER must be reduced to < 30% RTP within 4 hours. Alternately, the associated recirculation pump may be removed from service, since this performs the intended function of the instrumentation. The allowed Completion Time of 4 hours is reasonable, based on operating experience, to reduce THERMAL POWER to < 30% RTP from full power conditions in an orderly manner and without challenging plant systems.

SURVEILLANCE REQUIREMENTS

Reviewer's Note: Certain Frequencies are based on approved topical reports. In order for a licensee to use these Frequencies, the licensee must justify the Frequencies as required by the staff SER for the topical report.

The Surveillances are modified by a Note to indicate that when a channel is placed in an inoperable status solely for performance of required Surveillances, entry into associated Conditions and Required Actions may be delayed for up to 6 hours provided the associated Function maintains EOC-RPT trip capability. Upon completion of the Surveillance, or expiration of the 6 hour allowance, the channel must be returned to OPERABLE status or the applicable Condition entered and Required Actions taken. This Note is based on the reliability analysis (Ref. 5) assumption of the average time required to perform channel Surveillance. That

(continued)

BASES

**SURVEILLANCE
REQUIREMENTS
(continued)**

analysis demonstrated that the 6 hour testing allowance does not significantly reduce the probability that the recirculation pumps will trip when necessary.

SR 3.3.4.1.1

A CHANNEL FUNCTIONAL TEST is performed on each required channel to ensure that the entire channel will perform the intended function. Any setpoint adjustment shall be consistent with the assumptions of the current plant specific setpoint methodology.

The Frequency of 92 days is based on reliability analysis of Reference 5.

SR 3.3.4.1.2

Calibration of trip units provides a check of the actual trip setpoints. The channel must be declared inoperable if the trip setting is discovered to be less conservative than the Allowable Value specified in SR 3.3.4.1.3. If the trip setting is discovered to be less conservative than accounted for in the appropriate setpoint methodology, but is not beyond the Allowable Value, the channel performance is still within the requirements of the plant safety analysis. Under these conditions, the setpoint must be readjusted to be equal to or more conservative than accounted for in the appropriate setpoint methodology.

The Frequency of 92 days is based on assumptions of the reliability analysis (Ref. 5) and on the methodology included in the determination of the trip setpoint.

SR 3.3.4.1.3

CHANNEL CALIBRATION is a complete check of the instrument loop and the sensor. This test verifies the channel responds to the measured parameter within the necessary range and accuracy. CHANNEL CALIBRATION leaves the channel adjusted to account for instrument drifts between successive calibrations consistent with the plant specific setpoint methodology.

(continued)

BASES

SURVEILLANCE
REQUIREMENTS

SR 3.3.4.1.3 (continued)

The Frequency is based upon the assumption of an 18 month calibration interval in the determination of the magnitude of equipment drift in the setpoint analysis.

SR 3.3.4.1.4

The LOGIC SYSTEM FUNCTIONAL TEST demonstrates the OPERABILITY of the required trip logic for a specific channel. The system functional test of the pump breakers is included as a part of this test, overlapping the LOGIC SYSTEM FUNCTIONAL TEST, to provide complete testing of the associated safety function. Therefore, if a breaker is incapable of operating, the associated instrument channel(s) would also be inoperable.

The 18 month Frequency is based on the need to perform this Surveillance under the conditions that apply during a plant outage and the potential for an unplanned transient if the Surveillance were performed with the reactor at power. Operating experience has shown these components usually pass the Surveillance when performed at the 18 month Frequency.

SR 3.3.4.1.5

This SR ensures that an EOC-RPT initiated from the TSV-Closure and TCV Fast Closure, Trip Oil Pressure-Low Functions will not be inadvertently bypassed when THERMAL POWER is $\geq 30\%$ RTP. This involves calibration of the bypass channels. Adequate margins for the instrument setpoint methodologies are incorporated into the actual setpoint. Because main turbine bypass flow can affect this setpoint nonconservatively (THERMAL POWER is derived from first stage pressure) the main turbine bypass valves must remain closed at THERMAL POWER $\geq 30\%$ RTP to ensure that the calibration remains valid. If any bypass channel's setpoint is nonconservative (i.e., the Functions are bypassed at $\geq 30\%$ RTP, either due to open main turbine bypass valves or other reasons), the affected TSV-Closure and TCV Fast Closure, Trip Oil Pressure-Low Functions are considered inoperable. Alternatively, the bypass channel can be placed in the conservative condition (nonbypass). If placed in the

(continued)

BASES

**SURVEILLANCE
REQUIREMENTS**

SR 3.3.4.1.5 (continued)

nonbypass condition, this SR is met with the channel considered OPERABLE.

The Frequency of 18 months has shown that channel bypass failures between successive tests are rare.

SR 3.3.4.1.6

This SR ensures that the individual channel response times are less than or equal to the maximum values assumed in the accident analysis. The EOC-RPT SYSTEM RESPONSE TIME acceptance criteria are included in Reference 6.

A Note to the Surveillance states that breaker interruption time may be assumed from the most recent performance of SR 3.3.4.1.7. This is allowed since the time to open the contacts after energization of the trip coil and the arc suppression time are short and do not appreciably change, due to the design of the breaker opening device and the fact that the breaker is not routinely cycled.

EOC-RPT SYSTEM RESPONSE TIME tests are conducted on an 18 month STAGGERED TEST BASIS. Response times cannot be determined at power because operation of final actuated devices is required. Therefore, the 18 month Frequency is consistent with the typical industry refueling cycle and is based upon plant operating experience, which shows that random failures of instrumentation components that cause serious response time degradation, but not channel failure, are infrequent occurrences.

SR 3.3.4.1.7

This SR ensures that the RPT breaker interruption time (arc suppression time plus time to open the contacts) is provided to the EOC-RPT SYSTEM RESPONSE TIME test. The 60 month Frequency of the testing is based on the difficulty of performing the test and the reliability of the circuit breakers.

(continued)

BASES (continued)

REFERENCES

1. FSAR, Figure [] (EOC-RPT logic diagram).
 2. FSAR, Section [5.2.2].
 3. FSAR, Sections [15.1.1, 15.1.2, and 15.1.3].
 4. FSAR, Sections [5.5.16.1 and 7.6.10].
 5. GENE-770-06-1, "Bases For Changes To Surveillance Test Intervals And Allowed Out-Of-Service Times For Selected Instrumentation Technical Specifications," February 1991.
 6. FSAR, Section [5.5.16.2].
-

JUSTIFICATION FOR DEVIATIONS FROM NUREG-1433, REVISION 1
ISTS BASES: 3.3.4.1 - END OF CYCLE RECIRCULATION PUMP TRIP (EOC-RPT)
INSTRUMENTATION

1. This Bases has been deleted because the associated Specification has been deleted.

B 3.3 INSTRUMENTATION

B 3.3.4 Anticipated Transient Without Scram Recirculation Pump Trip (ATWS-RPT) Instrumentation

BASES

BACKGROUND

The ATWS-RPT System initiates an RPT, adding negative reactivity, following events in which a scram does not, but should occur, to lessen the effects of an ATWS event. Tripping the recirculation pumps adds negative reactivity from the increase in steam voiding in the core area as core flow decreases. When Reactor Vessel Water Level—Low Low Level 2 or Reactor Steam Dome Pressure—High setpoint is reached, the recirculation pump drive motor breakers trip.

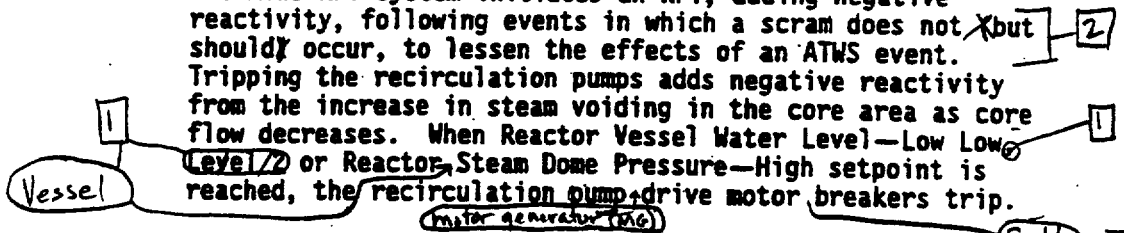

The ATWS-RPT System (Ref. 1) includes sensors, relays, bypass capability circuit breakers, and switches that are necessary to cause initiation of an RPT. The channels include electronic equipment (e.g., trip units) that compares measured input signals with pre-established setpoints. When the setpoint is exceeded, the channel output relay actuates, which then outputs an ATWS-RPT signal to the trip logic.

The ATWS-RPT consists of two independent trip systems, with two channels of Reactor Steam Dome Pressure—High and two channels of Reactor Vessel Water Level—Low Low Level 2 in each trip system. Each ATWS-RPT trip system is a two-out-of-two logic for each function. Thus, either two Reactor Water Level—Low Low Level 2 or two Reactor Pressure—High signals are needed to trip a trip system. The outputs of the channels in a trip system are combined in a logic so that either trip system will trip both recirculation pumps (by tripping the respective drive motor breakers).

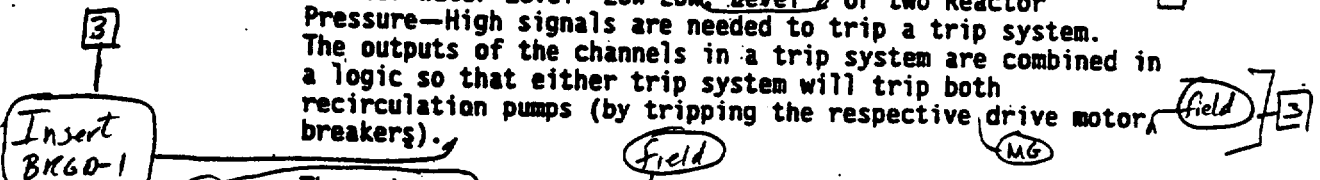

There is one drive motor breaker provided for each of the two recirculation pumps for a total of two breakers. The output of each trip system is provided to both recirculation pump breakers.

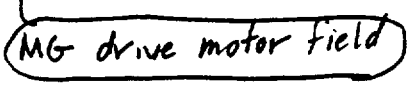

3

INSERT BKGD-1

Each Reactor Vessel Water Level - Low Low channel output must remain below the setpoint for approximately 9 seconds for the channel output to provide an actuation signal to the associated trip system.

3

to mitigate any accident or transient

BASES (continued)

APPLICABLE SAFETY ANALYSES, LCO, and APPLICABILITY

The ATWS-RPT is not assumed in the safety analysis. The ATWS-RPT initiates an RPT to aid in preserving the integrity of the fuel cladding following events in which a scram does not, but should, occur. Based on its contribution to the reduction of overall plant risk, however, the instrumentation is included as required by the NRC Policy Statement.

meets Criterion 4 of 10 CFR 51.36 (c)(2)(ii)

4

The OPERABILITY of the ATWS-RPT is dependent on the OPERABILITY of the individual instrumentation channel Functions. Each Function must have a required number of OPERABLE channels in each trip system, with their setpoints within the specified Allowable Value of SR 3.3.4.0.6. The actual setpoint is calibrated consistent with applicable setpoint methodology assumptions. Channel OPERABILITY also includes the associated recirculation pump drive motor breakers. A channel is inoperable if its actual trip setpoint is not within its required Allowable Value.

1

2

Allowable Values are specified for each ATWS-RPT Function specified in the LCO. Nominal trip setpoints are specified in the setpoint calculations. The nominal setpoints are selected to ensure that the setpoints do not exceed the Allowable Value between CHANNEL CALIBRATIONS. Operation with a trip setpoint less conservative than the nominal trip setpoint, but within its Allowable Value, is acceptable. Trip setpoints are those predetermined values of output at which an action should take place. The setpoints are compared to the actual process parameter (e.g., reactor vessel water level), and when the measured output value of the process parameter exceeds the setpoint, the associated device (e.g., trip unit) changes state. The analytic limits are derived from the limiting values of the process parameters obtained from the safety analysis.

3

(Ref. 2)

ATWS 3

Insert ASA 3

The Allowable Values are derived from the analytic limits, corrected for calibration, process, and some of the instrument errors. The trip setpoints are then determined accounting for the remaining instrument errors (e.g., drift). The trip setpoints derived in this manner provide adequate protection because instrumentation uncertainties, process effects, calibration tolerances, instrument drift, and severe environment errors (for channels that must function in harsh environments as defined by 10 CFR 50.49) are accounted for.

The individual Functions are required to be OPERABLE in MODE 1 to protect against common mode failures of the

(continued)

3

Insert ASA

The trip setpoints are determined from the analytic limits, corrected for defined process, calibration, and instrument errors. The Allowable Values are then determined, based on the trip setpoint values, by accounting for the calibration based errors. These calibration based errors are limited to reference accuracy, instrument drift, errors associated with measurement and test equipment, and calibration tolerance of loop components. The trip setpoints and Allowable Values determined in this manner provide adequate protection because instrument uncertainties, process effects, calibration tolerances, instrument drift, and severe environment errors (for channels that must function in harsh environments as defined by 10 CFR 50.49) are accounted for and appropriately applied for the instrumentation.

BASES

Vessel [1]

APPLICABLE SAFETY ANALYSES, LCO, and APPLICABILITY (continued)

Reactor Protection System by providing a diverse trip to mitigate the consequences of a postulated ATWS event. The Reactor Steam Dome Pressure—High and Reactor Vessel Water Level—Low Low Level 2 Functions are required to be OPERABLE in MODE 1, since the reactor is producing significant power and the recirculation system could be at high flow. During this MODE, the potential exists for pressure increases or low water level, assuming an ATWS event. In MODE 2, the reactor is at low power and the recirculation system is at low flow; thus, the potential is low for a pressure increase or low water level, assuming an ATWS event. Therefore, the ATWS-RPT is not necessary. In MODES 3 and 4, the reactor is shut down with all control rods inserted; thus, an ATWS event is not significant and the possibility of a significant pressure increase or low water level is negligible. In MODE 5, the one rod out interlock ensures that the reactor remains subcritical; thus, an ATWS event is not significant. In addition, the reactor pressure vessel (RPV) head is not fully tensioned and no pressure transient threat to the reactor coolant pressure boundary (RCPB) exists.

The specific Applicable Safety Analyses and LCO discussions are listed below on a Function by Function basis.

a. Reactor Vessel Water Level—Low Low Level 2 [1]

Low RPV water level indicates the capability to cool the fuel may be threatened. Should RPV water level decrease too far, fuel damage could result. Therefore, the ATWS-RPT System is initiated at Level 2 to aid in maintaining level above the top of the active fuel. The reduction of core flow reduces the neutron flux and THERMAL POWER and, therefore, the rate of coolant boiloff.

low low RPV water level [3]

differential pressure [3]

Reactor vessel water level signals are initiated from four Level transmitters that sense the difference between the pressure due to a constant column of water (reference leg) and the pressure due to the actual water level (variable leg) in the vessel.

Four channels of Reactor Vessel Water Level—Low Low Level 2, with two channels in each trip system, are available and required to be OPERABLE to ensure that

(continued)

BASES

Each channel includes a time delay relay which ... delays the Reactor Vessel Water Level-Low-Low Function channel output signal from providing input to the associated trip system

APPLICABLE SAFETY ANALYSES, LCO, and APPLICABILITY

a. Reactor Vessel Water Level—Low Low (Level 2)
(continued)

no single instrument failure can preclude an ATWS-RPT from this function on a valid signal. The Reactor Vessel Water Level—Low Low Allowable Value is chosen so that the system will not be initiated after a scram with feedwater still available, and for convenience with the reactor core isolation cooling and high pressure coolant injection

reactor vessel water level

The Reactor Vessel Water Level—Low Low Function trip is delayed since there is an insignificant affect on the ATWS consequences and it is desirable to avoid making the consequences of a loss of coolant accident more severe.

b. Reactor Steam Dome Pressure—High

Excessively high RPV pressure may rupture the RCPB. An increase in the RPV pressure during reactor operation compresses the steam voids and results in a positive reactivity insertion. This increases neutron flux and THERMAL POWER, which could potentially result in fuel failure and overpressurization. The Reactor Steam Dome Pressure—High Function initiates an RPT for transients that result in a pressure increase, counteracting the pressure increase by rapidly reducing core power generation. For the overpressurization event, the RPT aids in the termination of the ATWS event and, along with the safety valves, limits the peak RPV pressure to less than the ASME Section III Code Service Level C limits (1500 psig).

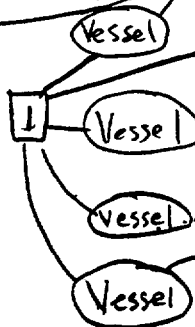

The Reactor Steam Dome Pressure—High signals are initiated from four pressure transmitters that monitor reactor steam dome pressure. Four channels of Reactor Steam Dome Pressure—High, with two channels in each trip system, are available and are required to be OPERABLE to ensure that no single instrument failure can preclude an ATWS-RPT from this function on a valid signal. The Reactor Steam Dome Pressure—High Allowable Value is chosen to provide an adequate margin to the ASME Section III Code Service Level C allowable Reactor Coolant System pressure.

ACTIONS

A Note has been provided to modify the ACTIONS related to ATWS-RPT instrumentation channels. Section 1.3, Completion

(continued)

BASES

ACTIONS
(continued)

Times, specifies that once a Condition has been entered, subsequent divisions, subsystems, components, or variables expressed in the Condition, discovered to be inoperable or not within limits, will not result in separate entry into the Condition. Section 1.3 also specifies that Required Actions of the Condition continue to apply for each additional failure, with Completion Times based on initial entry into the Condition. However, the Required Actions for inoperable ATWS-RPT instrumentation channels provide appropriate compensatory measures for separate inoperable channels. As such, a Note has been provided that allows separate Condition entry for each inoperable ATWS-RPT instrumentation channel.

A.1 and A.2

With one or more channels inoperable, but with ATWS-RPT capability for each Function maintained (refer to Required Actions B.1 and C.1 Bases), the ATWS-RPT System is capable of performing the intended function. However, the reliability and redundancy of the ATWS-RPT instrumentation is reduced, such that a single failure in the remaining trip system could result in the inability of the ATWS-RPT System to perform the intended function. Therefore, only a limited time is allowed to restore the inoperable channels to OPERABLE status. Because of the diversity of sensors available to provide trip signals, the low probability of extensive numbers of inoperabilities affecting all diverse Functions, and the low probability of an event requiring the initiation of ATWS-RPT, 14 days is provided to restore the inoperable channel (Required Action A.1). Alternately, the inoperable channel may be placed in trip (Required Action A.2), since this would conservatively compensate for the inoperability, restore capability to accommodate a single failure, and allow operation to continue. As noted, placing the channel in trip with no further restrictions is not allowed if the inoperable channel is the result of an inoperable breaker, since this may not adequately compensate for the inoperable breaker (e.g., the breaker may be inoperable such that it will not open). If it is not desired to place the channel in trip (e.g., as in the case where placing the inoperable channel would result in an RPT), or if the inoperable channel is the result of an inoperable breaker, Condition D must be entered and its Required Actions taken.

2
trip

2
in trip

(continued)

BASES

ACTIONS
(continued)

B.1

Required Action B.1 is intended to ensure that appropriate actions are taken if multiple, inoperable, untripped channels within the same Function result in the Function not maintaining ATWS-RPT trip capability. A Function is considered to be maintaining ATWS-RPT trip capability when sufficient channels are OPERABLE or in trip such that the ATWS-RPT System will generate a trip signal from the given Function on a valid signal, and both recirculation pumps can be tripped. This requires two channels of the Function in the same trip system to each be OPERABLE or in trip, and the recirculation pump drive motor breakers to be OPERABLE or in trip.

The 72 hour Completion Time is sufficient for the operator to take corrective action (e.g., restoration or tripping of channels) and takes into account the likelihood of an event requiring actuation of the ATWS-RPT instrumentation during this period and that one Function is still maintaining ATWS-RPT trip capability.

C.1

Required Action C.1 is intended to ensure that appropriate Actions are taken if multiple, inoperable, untripped channels within both Functions result in both Functions not maintaining ATWS-RPT trip capability. The description of a Function maintaining ATWS-RPT trip capability is discussed in the Bases for Required Action B.1 above.

The 1 hour Completion Time is sufficient for the operator to take corrective action and takes into account the likelihood of an event requiring actuation of the ATWS-RPT instrumentation during this period.

D.1 and D.2

With any Required Action and associated Completion Time not met, the plant must be brought to a MODE or other specified condition in which the LCO does not apply. To achieve this status, the plant must be brought to at least MODE 2 within 6 hours (Required Action D.2). Alternately, the associated recirculation pump may be removed from service since this

(continued)

① ①

BASES

ACTIONS

D.1 and D.2 (continued)

performs the intended function of the instrumentation (Required Action D.1). The allowed Completion Time of 6 hours is reasonable, based on operating experience, both to reach MODE 2 from full power conditions and to remove a recirculation pump from service in an orderly manner and without challenging plant systems.

SURVEILLANCE REQUIREMENTS

Reviewer's Note: Certain Frequencies are based on approved topical reports. In order for a licensee to use these times, the licensee must justify the Frequencies as required by the staff Safety Evaluation Report for the topical report.

⑤

The Surveillances are modified by a Note to indicate that when a channel is placed in an inoperable status solely for performance of required Surveillances, entry into the associated Conditions and Required Actions may be delayed for up to 6 hours provided the associated Function maintains ATWS-RPT trip capability. Upon completion of the Surveillance, or expiration of the 6 hour allowance, the channel must be returned to OPERABLE status or the applicable Condition entered and Required Actions taken. This Note is based on the reliability analysis (Ref. ②) assumption of the average time required to perform channel Surveillance. That analysis demonstrated that the 6 hour testing allowance does not significantly reduce the probability that the recirculation pumps will trip when necessary.

③
③

SR 3.3.4.0.1

Performance of the CHANNEL CHECK once every 12 hours ensures that a gross failure of instrumentation has not occurred. A CHANNEL CHECK is normally a comparison of the parameter indicated on one channel to a similar parameter on other channels. It is based on the assumption that instrument channels monitoring the same parameter should read approximately the same value. Significant deviations between the instrument channels could be an indication of excessive instrument drift in one of the channels or

(continued)

BASES

**SURVEILLANCE
REQUIREMENTS**

SR 3.3.4.2.1 (continued)

something even more serious. A CHANNEL CHECK will detect gross channel failure; thus, it is key to verifying the instrumentation continues to operate properly between each CHANNEL CALIBRATION.

Agreement criteria are determined by the plant staff based on a combination of the channel instrument uncertainties, including indication and readability. If a channel is outside the criteria, it may be an indication that the instrument has drifted outside its limit.

The Frequency is based upon operating experience that demonstrates channel failure is rare. The CHANNEL CHECK supplements less formal, but more frequent, checks of channels during normal operational use of the displays associated with the required channels of this LCO.

SR 3.3.4.2.2

A CHANNEL FUNCTIONAL TEST is performed on each required channel to ensure that the ~~channel~~ channel will perform the intended function.

Any setpoint adjustment shall be consistent with the assumptions of the current plant specific setpoint methodology.

The Frequency of 92 days is based on the reliability analysis of Reference 2.

SR 3.3.4.2.3

Calibration of trip units provides a check of the actual trip setpoints. The channel must be declared inoperable if the trip setting is discovered to be less conservative than the Allowable Value specified in SR 3.3.4.2.4. If the trip setting is discovered to be less conservative than the setting accounted for in the appropriate setpoint methodology, but is not beyond the Allowable Value, the

(continued)

move to page
B 3.3-99 as
indicated

insert SR 3.3.2.3 from page B 3.3-98 as indicated

BASES

SURVEILLANCE REQUIREMENTS

SR 3.3.4.0.3 (continued)

engineering judgement and 3

ATWS 3

channel performance is still within the requirements of the plant safety analysis. Under these conditions, the setpoint must be readjusted to be equal to or more conservative than accounted for in the appropriate setpoint methodology.

The Frequency of 21 days is based on the reliability analysis of Reference 2. of these components 3

SR 3.3.4.0.4

A CHANNEL CALIBRATION is a complete check of the instrument loop and the sensor. This test verifies the channel responds to the measured parameter within the necessary range and accuracy. CHANNEL CALIBRATION leaves the channel adjusted to account for instrument drifts between successive calibrations consistent with the plant specific setpoint methodology.

including the time delay relays associated with the Reactor Vessel Water Level-Low Low Function 3

The Frequency is based upon the assumption of an 18 month calibration interval in the determination of the magnitude of equipment drift in the setpoint analysis. 24 1

SR 3.3.4.0.5

The LOGIC SYSTEM FUNCTIONAL TEST demonstrates the OPERABILITY of the required trip logic for a specific channel. The system functional test of the pump breakers is included as part of this Surveillance and overlaps the LOGIC SYSTEM FUNCTIONAL TEST to provide complete testing of the assumed safety function. Therefore, if a breaker is incapable of operating, the associated instrument channel(s) would be inoperable.

24 1

The 18 month Frequency is based on the need to perform this Surveillance under the conditions that apply during a plant outage and the potential for an unplanned transient if the Surveillance were performed with the reactor at power. Operating experience has shown these components usually pass the Surveillance when performed at the 18 month Frequency. 24 1

(continued)

6

BASES (continued)

Section 7.8

3

REFERENCES

1. FSAR, Figure 7.1 ATWS-RPT Logic Diagram.

NEOS-770-06-1, "Bases for Changes To Surveillance Test Intervals and Allowed Out-of-Service Times For Selected Instrumentation Technical Specifications," February 1992.

December 1992

GENE

3

2. UFSAR, Section 15.8

JUSTIFICATION FOR DEVIATIONS FROM NUREG-1433, REVISION 1
ITS BASES: 3.3.4.1 - ATWS-RPT INSTRUMENTATION

1. Changes have been made to reflect those changes made to the Specification. The following requirements have been renumbered, where applicable, to reflect the changes.
2. Editorial change made for enhanced clarity or to be consistent with similar statements in other places in the Bases.
3. Changes have been made (additions, deletions, and/or changes to the NUREG) to reflect the plant specific methodology, nomenclature, number, reference, system description, analysis description, or licensing basis description.
4. The proper 10 CFR 50.36(c)(2)(ii) criterion has been used. The current wording was developed prior to the issuance of the change to 10 CFR 50.36, which uses criterion 4 for the current words in the NUREG.
5. This Reviewer's Note has been deleted. This information is for the NRC reviewer to be keyed in to what is needed to meet this requirement. This is not meant to be retained on the final version of the plant-specific submittal.
6. The brackets have been removed and the proper plant specific information/value has been provided.

All changes are [2] unless otherwise indicated

B 3.3 INSTRUMENTATION

B 3.3.5.1 Emergency Core Cooling System (ECCS) Instrumentation

BASES

BACKGROUND

The purpose of the ECCS instrumentation is to initiate appropriate responses from the systems to ensure that the fuel is adequately cooled in the event of a design basis accident or transient.

For most anticipated operational occurrences and Design Basis Accidents (DBAs), a wide range of dependent and independent parameters are monitored.

The ECCS instrumentation actuates core spray (CS), low pressure coolant injection (LPCI), high pressure coolant injection (HPCI), Automatic Depressurization System (ADS), and the diesel generators (DGs). The equipment involved with each of these systems is described in the Bases for LCO 3.5.1, "ECCS—Operating".

and LCO 3.8.1,
"AC Sources - Operating"

(Coincident with Reactor Steam Dome Pressure - Low (Permissive))

Core Spray System

The CS System may be initiated by either automatic or manual means. Automatic initiation occurs for conditions of Reactor Vessel Water Level—Low Low Low Level or Drywell Pressure—High. Each of these diverse variables is monitored by four redundant transmitters, which are in turn, connected to four trip units. The outputs of the eight trip units are connected to relays whose contacts are arranged in a one-out-of-two taken twice logic (1-2, 2-2) trip systems for each function.

differential pressure switches and the Drywell Pressure - High Variable is monitored by four redundant pressure switches.

The output of each switch is connected to relays whose contacts input into two trip systems. Each trip system is

Although manual initiation requires manipulation of individual pump and valve control switches

The Reactor Vessel Water Level—Low Low Variable is

Insert BK60-1

otherwise the CS pumps start in approximately 10 seconds after AC power is available from the DG.

The high drywell pressure initiation signal is a sealed in signal and must be manually reset. The CS System can be reset if reactor water level has been restored, even if the high drywell pressure condition persists. The logic can also be initiated by use of a manual push button (one push button per subsystem). Upon receipt of an initiation signal, the CS pumps are started immediately after power is available if offsite.

The CS test line isolation valve, which is also a primary containment isolation valve (PCIV), is closed on a CS initiation signal to allow full system flow assumed in the

(continued)

2

Insert BKGD-1

The Reactor Steam Dome Pressure-Low (Permissive) variable is monitored by two redundant pressure switches. The output of each switch is connected to relays whose contacts input into two trip systems. Each trip system is arranged in a one-out-of-two logic. Each trip system will delay CS pump start logic on low low reactor vessel water level until reactor steam dome pressure has fallen to a value below the CS System's maximum design pressure. The CS pumps start logic will receive the high drywell pressure signals without delay, however, the opening of the injection valves will be delayed for both Functions. Each trip system will start one CS pump and provide signals to the associated CS subsystem valves. Each CS subsystem also receives an ADS initiation signal.

All changes are 2 unless otherwise indicated

BASES

BACKGROUND

Core Spray System (continued)

accident analyses and maintain primary containment isolated in the event CS is not operating.

The CS pump discharge flow is monitored by a flow transmitter. When the pump is running and discharge flow is low enough so that pump overheating may occur, the minimum flow return line valve is opened. The valve is automatically closed if flow is above the minimum flow setpoint to allow the full system flow assumed in the accident analysis.

The CS System also monitors the pressure in the reactor to ensure that, before the injection valves open, the reactor pressure has fallen to a value below the CS System's maximum design pressure. The variable is monitored by four redundant transmitters, which are, in turn, connected to four trip units. The outputs of the trip units are connected to relays whose contacts are arranged in a one-out-of-two taken twice logic.

The output of each switch is connected to relays whose contacts input into two trip systems. Each trip system is

Low Pressure Coolant Injection System

The LPCI is an operating mode of the Residual Heat Removal (RHR) System, with two LPCI subsystems. The LPCI subsystems may be initiated by automatic or manual means. Automatic initiation occurs for conditions of Reactor Vessel Water Level - Low Low (or Level) or Drywell Pressure - High or both. Each of these diverse variables is monitored by four redundant transmitters, which in turn, are connected to four trip units. The outputs of the trip units are connected to relays whose contacts are arranged in a one-out-of-two taken twice logic (i.e., two trip systems) for each function. Once an initiation signal is received by the LPCI control circuitry, the signal is sealed in until manually reset.

although manual initiation requires manipulation of individual pump and valve control switches

(coincident with Reactor Steam Dome Pressure - Low (Permissive))

The Reactor Vessel Water Level - Low Low Variable is

differential pressure switches and the Drywell Pressure - High variable is monitored by four redundant pressure switches.

BK 6D-2

Upon receipt of an initiation signal, the LPCI C pump starts after a 0.5 second delay when power is available. The LPCI A, B, and D pumps, are started after a 2 second delay after AC power from the associated DG is available. This time delay

limits the loading of the standby power sources. Each LPCI subsystem's discharge flow is monitored by a flow transmitter. When a pump is running and discharge flow is start immediately if offsite power is available, otherwise the pumps

immediately

otherwise the pumps start immediately if AC power is available from the associated DG

5

(continued)

2

Insert BKGD-2

The Reactor Steam Dome Pressure-Low (Permissive) variable is monitored by two redundant pressure switches. The output of each switch is connected to relays whose contacts input into two trip systems. Each trip system is arranged in a one-out-of-two logic. Each trip system will delay LPCI pump start logic on low low reactor vessel water level until reactor steam dome pressure has fallen to a value below the LPCI System's maximum design pressure. The LPCI pumps start logic will receive the high drywell pressure signals without delay, however, the opening of the injection valves will be delayed for both Functions. Each trip system will start the associated LPCI pumps and provide signals to the associated LPCI valves. Each LPCI subsystem also receives an ADS initiation signal.

All changes are [Z] unless otherwise indicated

BASES

BACKGROUND

Low Pressure Coolant Injection System (continued)

low enough so that pump overheating may occur, the respective minimum flow return line valve is opened. If flow is above the minimum flow setpoint, the valve is automatically closed to allow the full system flow assumed in the analyses.

The RHR test line suppression pool cooling isolation valve, suppression pool spray isolation valves, and containment spray isolation valves (which are also PCIVs) are also closed on a LPCI initiation signal to allow the full system flow assumed in the accident analyses and maintain primary containment isolated in the event LPCI is not operating.

Insert BK6D-3

The LPCI System monitors the pressure in the reactor to ensure that, before an injection valve opens, the reactor pressure has fallen to a value below the LPCI System's maximum design pressure. The variable is monitored by four redundant transmitters, which are, in turn, connected to four trip units. The outputs of the trip units are connected to relays whose contacts are arranged in a one-out-of-two taken twice logic. Additionally, instruments are provided to close the recirculation pump discharge valves to ensure that LPCI flow does not bypass the core when it injects into the recirculation lines. The variable is monitored by four redundant transmitters, which are, in turn, connected to four trip units. The outputs of the trip units are connected to relays whose contacts are arranged in a one-out-of-two taken twice logic.

Low reactor water level in the shroud is detected by two additional instruments to automatically isolate other modes of RHR (e.g., suppression pool cooling) when LPCI is required. Manual overrides for these isolations are provided.

High Pressure Coolant Injection System

The Reactor Vessel Water Level-Low Low Variable is

The HPCI System may be initiated by either automatic or manual means. Automatic initiation occurs for conditions of Reactor Vessel Water Level-Low Low, Level 2 or Drywell Pressure-High. Each of these variables is monitored by four redundant transmitters, which are, in turn, connected to four trip units. The outputs of the trip units are

differential pressure switches and the Drywell Pressure-High variable is monitored by four redundant pressure switches.

each switch is

(continued)

The LPCI System initiation logic also contains LPCI Loop Select Logic whose purpose is to identify and direct LPCI flow to the unbroken recirculation loop if a Design Basis Accident (DBA) occurs. The LPCI Loop Select Logic is initiated upon the receipt of either a LPCI Reactor Vessel Water Level - Low signal or a LPCI Drywell Pressure - High signal, as discussed previously. When initiated, the LPCI Loop Select Logic first determines recirculation pump operation by sensing the differential pressure (dp) between the suction and discharge of each pump. There are four dp switches monitoring each recirculation loop which are, in turn, connected to relays whose contacts are connected to two trip systems. The dp switches will trip when the dp across the pump is approximately 8 psid. The contacts are arranged in a one-out-of-two taken twice logic for each recirculation pump. If the logic senses that either pump is not running, i.e., single loop operation, then a trip signal is sent to both recirculation pumps to eliminate the possibility of pipe breaks being masked by the operating recirculation pump pressure. However, the pump trip signal is delayed approximately 0.5 seconds to ensure that at least one pump is off since the break detection sensitivity is greater with both pumps running. If a pump trip signal is generated, reactor steam dome pressure must drop to a specified value before the logic will continue. This adjusts the selection time to optimize sensitivity and still ensure that LPCI injection is not unnecessarily delayed. The reactor steam dome pressure is sensed by four pressure switches which in turn are connected to relays whose contacts are connected to two trip systems. The contacts are arranged in a one-out-of-two taken twice logic. After the satisfaction of this pressure requirement or if both recirculation pumps indicate they are running, a 2 second time delay is provided to allow momentum effects to establish the maximum differential pressure for loop selection. Selection of the unbroken recirculation loop is then initiated. This is done by comparing the absolute pressure of the two recirculation riser loops. The broken loop is indicated by a lower pressure than the unbroken loop. The loop with the higher pressure is then used for LPCI injection. If, after a small time delay (approximately 0.5 seconds), the pressure in loop A is not indicating higher than loop B, the logic will provide a signal to close the B recirculation loop discharge valve, open the LPCI injection valve to the B recirculation loop and close the LPCI injection valve to the A recirculation loop. This is the "default" choice in the LPCI Loop Select Logic. If recirculation loop A pressure indicates higher than loop B pressure (> 1 psig), the recirculation discharge valve in loop A is closed, the LPCI injection valve to loop A is signaled to open and the LPCI injection valve to loop B is signaled to close. The four dp switches which provide input to this portion of the logic detect the pressure difference between the corresponding risers to the jet pumps in each recirculation loop. The four dp switches are connected to relays whose contacts are connected to two trip systems. The contacts in each trip system are arranged in a one-out-of-two taken twice logic. There are two redundant trip systems in the LPCI Loop Select Logic. The complete logic in each trip system must actuate for operation of the LPCI Loop Select Logic.

All changes are [2] unless otherwise indicated

BASES

BACKGROUND

High Pressure Coolant Injection System (continued)

connected to relays whose contacts are arranged in a one-out-of-two taken twice logic for each function.

The logic can also be initiated by use of a Manual Initiation push button.

differential pressure switch

The HPCI pump discharge flow is monitored by a flow transmitter. When the pump is running and discharge flow is low enough so that pump overheating may occur, the minimum flow return line valve is opened. The valve is automatically closed if flow is above the minimum flow setpoint to allow the full system flow assumed in the accident analysis.

The HPCI test line isolation valve (which is also a PCIV) is closed upon receipt of a HPCI initiation signal to allow the full system flow assumed in the accident analysis and maintain primary containment isolated in the event HPCI is not operating.

Contaminated
The HPCI System is normally aligned to both CSTs.

The HPCI System also monitors the water levels in the condensate storage tanks (CST) and the suppression pool because these are the two sources of water for HPCI operation. Reactor grade water in the CST is the normal source.

When the valves are fully open.

pump

Upon receipt of a HPCI initiation signal, the CST suction valve is automatically signaled to open (it is normally in the open position) unless both suppression pool suction valves are open. If the water level in the CST falls below a preselected level, first the suppression pool suction valves automatically open, and then the CST suction valve automatically closes. Two level switches are used to detect low water level in the CST. Either switch can cause the suppression pool suction valves to open and the CST suction valve to close. The suppression pool suction valves also automatically open and the CST suction valve closes if high water level is detected in the suppression pool. To prevent losing suction to the pump, the suction valves are interlocked so that one suction path must be open before the other automatically closes.

The outputs for these switches are provided to logics of HPCI in both Unit 1 and Unit 2

pump discharge

The HPCI provides makeup water to the reactor until the reactor vessel water level reaches the Reactor Vessel Water Level-High Level B trip, at which time the HPCI turbine trips, which causes the turbine's stop valve and the injection valves to close. The logic is two-out-of-two to provide high reliability of the HPCI System. The HPCI

(continued)

All changes are [2] unless otherwise indicated

BASES

BACKGROUND

High Pressure Coolant Injection System (continued)

System automatically restarts if a Reactor Vessel Water Level—Low Low (Level 2) signal is subsequently received.

Automatic Depressurization System

Insert ADS-1

although manual initiation requires manipulation of each individual relief valve control switch

The ADS may be initiated by either automatic or manual means. Automatic initiation occurs when signals indicating Reactor Vessel Water Level—Low Low (Low Level 2), Drywell Pressure—High (of ADS Bypass Low Water Level Actuation Timer; Confirmed Reactor Vessel Water Level—Low Level 3, and CS or LPCI Pump Discharge Pressure—High are all present and the ADS Initiation Timer has timed out. There are two transmitters each for Reactor Vessel Water Level—Low Low (Low Level 2) and Drywell Pressure—High, and one transmitter for confirmed Reactor Vessel Water Level—Low Level 3 in each of the two ADS trip systems. Each of these transmitters connects to a trip unit, which then drives a relay whose contacts form the initiation logic.

differential pressure switches

two pressure switches for

switches

Low Low

to be

and the Low Low Water Level Actuation Time delay Setpoint are

Each ADS trip system includes a time delay between satisfying the initiation logic and the actuation of the ADS valves. The ADS Initiation Timer time delay setpoint, chosen long enough that the HPCI has sufficient operating time to recover to a level above Level 1, yet not so long that the LPCI and CS Systems are unable to adequately cool the fuel if the HPCI fails to maintain that level. An alarm in the control room is annunciated when either of the timers is timing. Resetting the ADS initiation signals resets the ADS Initiation Timers.

pumps

switches

all

However, only the switches in the associated division are required to be OPERABLE for each trip system

The ADS also monitors the discharge pressures of the four LPCI pumps and the two CS pumps. Each ADS trip system includes two discharge pressure permissive transmitters from both CS and from the LPCI pumps in the associated Division (i.e., Division 1 LPCI subsystems A and B input to ADS trip system A, and Division 2 LPCI subsystems C and D input to ADS trip system B). The signals are used as a permissive for ADS actuation, indicating that there is a source of core coolant available once the ADS has depressurized the vessel. Any one of the six low pressure pumps is sufficient to permit automatic depressurization.

(continued)

2

INSERT ADS - 1

ADS automatic initiation also occurs when signals indicating Reactor Vessel Water Level-Low Low are present and the ADS Low Low Water Level Actuation Timer times out. However, this initiation occurs since this logic provides a direct initiation of the associated low pressure ECCS pumps, thereby bypassing the CS or LPCI Reactor Steam Dome Pressure (Permissive) channels. After the pumps start the ADS Drywell Pressure-High contacts are effectively bypassed and the above logic is completed after CS or LPCI Pump Discharge Pressure-High channels are actuated and the ADS Initiation Timer has also timed out.

All changes are [2] unless otherwise indicated

In addition, each string receives a contact input of a pressure switch associated with each CS and LPCI pump via the use of auxiliary relays and one string includes the ADS initiation timer

BASES

BACKGROUND

(low low reactor vessel and high drywell pressure)

Automatic Depressurization System (continued)

Function channel

The ADS logic in each trip system is arranged in two strings. Each string has a contact from each of the following variables: Reactor Vessel Water Level—Low Low and Low Level 2; Drywell Pressure—High or Low Water Level Actuation timer. One of the two strings in each trip system must also have a confirmed Reactor Vessel Water Level—Low Level 2. All contacts in both logic strings must close, the ADS initiation timer must time out, and a CS or LPCI pump discharge pressure signal must be present to initiate an ADS trip system. Either the A or B trip system will cause all the ADS relief valves to open. Once the Drywell Pressure—High signal, the ADS Low Water Level Actuation timer, or the ADS initiation signal is present, it is individually sealed in until manually reset.

Insert ADS-2

Manual inhibit switches are provided in the control room for the ADS; however, their function is not required for ADS OPERABILITY (provided ADS is not inhibited when required to be OPERABLE).

and auxiliary equipment room

Diesel Generators

The Reactor Water Level - Low Low variable is monitored by four redundant differential pressure switches and the Drywell Pressure-High variable is

pressure switches

Each trip system is arranged in a

One trip system starts the unit DG and the other trip system starts the common DG (DG 112)

The DGs may be initiated by either automatic or manual means. Automatic initiation occurs for conditions of Reactor Vessel Water Level—Low Low Low Level 2 or Drywell Pressure—High. The DGs are also initiated upon loss of voltage signals. (Refer to the Bases for LCO 3.3.8.1, "Loss of Power (LOP) Instrumentation," for a discussion of these signals.) Each of these diverse variables is monitored by four redundant transmitters, which are, in turn, connected to four trip units. The outputs of the four trip units are connected to relays whose contacts are connected to a one-out-of-two taken twice logic to initiate all three DGs (2A, 1B, and 2D). The DGs receive their initiation signals from the CS System initiation logic. The DGs can also be started manually from the control room and locally from the associated DG room. The DG initiation signal is a sealed in signal and must be manually reset. The DG initiation logic is reset by resetting the associated ECCS initiation logic. Upon receipt of a loss of coolant accident (LOCA) initiation signal, each DG is automatically started, is ready to load in approximately 2 seconds, and will run in standby conditions (rated voltage and speed, with the DG output

each switch is

two trip systems

10

(continued)

2

INSERT ADS - 2

Both trip strings associated with each ADS logic will also trip if both Reactor Vessel Water Level-Low Low Function channel contacts close, the ADS Low Low Water Level Actuation Timer times out, and a CS or LPCI pump discharge pressure signal is present in each string. This is accomplished since with both Reactor Vessel Water Level-Low Low Function channels tripped and with the ADS Low Low Water Level Actuation Timer timed out the associated low pressure ECCS pumps will receive an initiation signal from this logic, thus bypassing the associated ADS Drywell Pressure-High and CS or LPCI Reactor Steam Dome Pressure (Permissive) Function channels, to start the low pressure ECCS pumps.

All changes are [2] unless otherwise indicated

BASES

BACKGROUND

Diesel Generators (continued) System (ESS)

Essential breaker open) ^{Service} The DGs will only energize their respective ~~Engineered Safety Feature~~ buses if a loss of offsite power occurs. (Refer to Bases for LCO 3.3.8.1.) [3]

APPLICABLE SAFETY ANALYSES, LCO, and APPLICABILITY

The actions of the ECCS are explicitly assumed in the safety analyses of References 1, 2, and 3. The ECCS is initiated to preserve the integrity of the fuel cladding by limiting the post LOCA peak cladding temperature to less than the 10 CFR 50.46 limits.

10 CFR 50.36 (c)(7)(i)

ECCS instrumentation satisfies Criterion 3 of ~~the NRC Policy Statement~~. Certain instrumentation Functions are retained for other reasons and are described below in the individual Functions discussion.

The OPERABILITY of the ECCS instrumentation is dependent upon the OPERABILITY of the individual instrumentation channel Functions specified in Table 3.3.5.1-1. Each Function must have a required number of OPERABLE channels, with their setpoints within the specified Allowable Values, where appropriate. The actual setpoint is calibrated consistent with applicable setpoint methodology assumptions. Each ECCS subsystem must also respond within its assumed response time. Table 3.3.5.1-1, footnote (b), is added to show that certain ECCS instrumentation Functions are also required to be OPERABLE to perform DG initiation and actuation of other Technical Specifications (TS) equipment. [4]

[1] Allowable Values are specified for each ECCS Function specified in the table. Nominal trip setpoints are specified in the setpoint calculations. The nominal setpoints are selected to ensure that the setpoints do not exceed the Allowable Value between CHANNEL CALIBRATIONS. Operation with a trip setpoint less conservative than the nominal trip setpoint, but within its Allowable Value, is acceptable. A channel is inoperable if its actual trip setpoint is not within its required Allowable Value. Trip setpoints are those predetermined values of output at which an action should take place. The setpoints are compared to the actual process parameter (e.g., reactor vessel water level), and when the measured output value of the process parameter exceeds the setpoint, the associated device (e.g.,

(continued)

BASES

APPLICABLE
SAFETY ANALYSES,
LCO, and
APPLICABILITY
(continued)

Insert
ASA
2

trip unit) changes state. The analytic limits are derived from the limiting values of the process parameters obtained from the safety analysis. The Allowable values are derived from the analytic limits, corrected for calibration, process, and some of the instrument errors. The trip setpoints are then determined, accounting for the remaining instrument errors (e.g., drift). The trip setpoints derived in this manner provide adequate protection because instrumentation uncertainties, process effects, calibration tolerances, instrument drift, and severe environment errors (for channels that must function in harsh environments as defined by 10/CFR 50.49) are accounted for.

In general, the individual Functions are required to be OPERABLE in the MODES or other specified conditions that may require ECCS (or DG) initiation to mitigate the consequences of a design basis transient or accident. To ensure reliable ECCS and DG function, a combination of Functions is required to provide primary and secondary initiation signals.

The specific Applicable Safety Analyses, LCO, and Applicability discussions are listed below on a Function by Function basis.

Core Spray and Low Pressure Coolant Injection Systems

1.a. 2.a. Reactor Vessel Water Level—Low Low (Low, Level) 4

Low Low
4

Low reactor pressure vessel (RPV) water level indicates that the capability to cool the fuel may be threatened. Should RPV water level decrease too far, fuel damage could result. The low pressure ECCS and associated DGs are initiated at LEVEL 1 to ensure that core spray and flooding functions are available to prevent or minimize fuel damage. The Reactor Vessel Water Level—Low Low Low, Level is one of the Functions assumed to be OPERABLE and capable of initiating the ECCS during the transients analyzed in References 1 and 3. In addition, the Reactor Vessel Water Level—Low Low Low, Level Function is directly assumed in the analysis of the recirculation line break (Ref. 2). The core cooling function of the ECCS, along with the scram action of the Reactor Protection System (RPS), ensures that the fuel peak cladding temperature remains below the limits of 10 CFR 50.46. 4

(continued)

2

Insert ASA-1

The trip setpoints are determined from the analytic limits, corrected for defined process, calibration, and instrument errors. The Allowable Values are then determined, based on the trip setpoint values, by accounting for the calibration based errors. These calibration based errors are limited to reference accuracy, instrument drift, errors associated with measurement and test equipment, and calibration tolerance of loop components. The trip setpoints and Allowable Values determined in this manner provide adequate protection because instrument uncertainties, process effects, calibration tolerances, instrument drift, and severe environment errors (for channels that must function in harsh environments as defined by 10 CFR 50.49) are accounted for and appropriately applied for the instrumentation.

Some Functions (i.e. Functions 1.c, 1.d, 2.c, 4.d, 4.e, 5.d, and 5.e) have both an upper and lower analytic limit that must be evaluated. The Allowable Values and trip setpoints are derived from both an upper and lower analytic limit using the methodology describe above. Due to the upper and lower analytic limits, Allowable Values of these Functions appear to incorporate a range. However, the upper and lower Allowable Values are unique, with each Allowable Value associated with one unique analytic limit and trip setpoint.

All changes are [2] unless otherwise indicated

BASES

APPLICABLE SAFETY ANALYSES, LCO, and APPLICABILITY

1.a. 2.a. Reactor Vessel Water Level—Low Low (Low/Level 1)

differential pressure switches

Reactor Vessel Water Level—Low Low (Low/Level 1) signals are initiated from four ~~Level transmitters~~ that sense the difference between the pressure due to a constant column of water (reference leg) and the pressure due to the actual water level (variable leg) in the vessel.

The Reactor Vessel Water Level—Low Low (Low/Level 1) Allowable Value is chosen to allow time for the low pressure core flooding systems to activate and provide adequate cooling.

Four channels of Reactor Vessel Water Level—Low Low (Low/Level 1) Function are only required to be OPERABLE when the ECCS or DG(s) are required to be OPERABLE to ensure that no single instrument failure can preclude ECCS and DG initiation. Refer to LCO 3.5.1 and LCO 3.5.2, "ECCS—Shutdown," for Applicability Bases for the low pressure ECCS subsystems; LCO 3.8.1, "AC Sources—Operating"; and LCO 3.8.2, "AC Sources—Shutdown," for Applicability Bases for the DGs.

Also, four channels of the LPCI Reactor Vessel Water Level—Low Low Function are only required to be OPERABLE when the LPCI System is required to be OPERABLE to ensure no single instrument failure can preclude LPCI initiation.

1.b. 2.b. Drywell Pressure—High

High pressure in the drywell could indicate a break in the reactor coolant pressure boundary (RCPB). The low pressure ECCS and associated DGs are initiated upon receipt of the Drywell Pressure—High Function in order to minimize the possibility of fuel damage. The Drywell Pressure—High Function, along with the Reactor Water Level—Low Low (Low/Level 1) Function, is directly assumed in the analysis of the recirculation line break (Ref. 4). The core cooling function of the ECCS, along with the scram action of the RPS, ensures that the fuel peak cladding temperature remains below the limits of 10 CFR 50.46.

switches

High drywell pressure signals are initiated from four pressure ~~transmitters~~ that sense drywell pressure. The Allowable Value was selected to be as low as possible and be indicative of a LOCA inside primary containment.

The Drywell Pressure—High Function is required to be OPERABLE when the ECCS or DG is required to be OPERABLE in conjunction with times when the primary containment is

(continued)

BASES

All changes are [2] unless otherwise indicated

APPLICABLE SAFETY ANALYSES, LCO, and APPLICABILITY

Also, four channels

of the LPCI Drywell Pressure-High Function are required to be OPERABLE in MODES 1, 2, and 3 to ensure no single instrument failure can preclude LPCI initiation.

The channels also delays CS and LPCI pump starts on Reactor Vessel Water Level-Low low until reactor steam dome pressure is below the setpoint

1.b. 2.b. Drywell Pressure-High (continued)

required to be OPERABLE. Thus, four channels of the CS ~~and~~ LPCI Drywell Pressure-High Function are required to be OPERABLE in MODES 1, 2, and 3 to ensure that no single instrument failure can preclude ECCS and DG initiation. In MODES 4 and 5, the Drywell Pressure-High Function is not required, since there is insufficient energy in the reactor to pressurize the primary containment to Drywell Pressure-High setpoint. Refer to LCO 3.5.1 for Applicability Bases for the low pressure ECCS subsystems and to LCO 3.8.1 for Applicability Bases for the DGs.

1.c. 2.c. Reactor Steam Dome Pressure-Low (Injection Permissive)

Low reactor steam dome pressure signals are used as permissives for the low pressure ECCS subsystems. This ensures that, prior to opening the injection valves of the low pressure ECCS subsystems, the reactor pressure has fallen to a value below these subsystems' maximum design pressure. The Reactor Steam Dome Pressure-Low is one of the Functions assumed to be OPERABLE and capable of permitting initiation of the ECCS during the transients analyzed in References 1 and 3. In addition, the Reactor Steam Dome Pressure-Low Function is directly assumed in the analysis of the recirculation line break (Ref. 2). The core cooling function of the ECCS, along with the scram action of the RPS, ensures that the fuel peak cladding temperature remains below the limits of 10 CFR 50.46.

[4]
(Permissive)
two switches

The Reactor Steam Dome Pressure-Low signals are initiated from ~~four~~ pressure transmitters that sense the reactor dome pressure.

Steam

The Allowable Value is low enough to prevent overpressuring the equipment in the low pressure ECCS, but high enough to ensure that the ECCS injection prevents the fuel peak cladding temperature from exceeding the limits of 10 CFR 50.46.

Four channels of Reactor Steam Dome Pressure-Low Function are only required to be OPERABLE when the ECCS is required to be OPERABLE to ensure that no single instrument failure can preclude ECCS initiation. Refer to LCO 3.5.1 and

(continued)

The LPCI Pump Discharge Flow - Low (Bypass) Function is only required to be OPERABLE for opening since LPCI minimum flow values are assumed to remain open during the transients and accidents analyzed in References 1, 2, and 3.

ECCS Instrumentation
B 3.3.5.1

All changes are [2] unless otherwise indicated

BASES

APPLICABLE SAFETY ANALYSES, LCO, and APPLICABILITY 1.c. 2.c. Reactor Steam Dome Pressure—Low (Injection Permissive) (continued) [4]

LCO 3.5.2 for Applicability Bases for the low pressure ECCS subsystems. [4]

1.d. 2.d. Core Spray and Low Pressure Coolant Injection Pump Discharge Flow—Low (Bypass)

sufficiently

The minimum flow instruments are provided to protect the associated low pressure ECCS pump from overheating when the pump is operating and the associated injection valve is not open. The minimum flow line valve is opened when low flow is sensed, and the valve is automatically closed when the flow rate is adequate to protect the pump. The CS Pump Discharge Flow—Low Function is assumed to be OPERABLE and capable of closing the minimum flow valves to ensure that the low pressure ECCS flows assumed during the transients and accidents analyzed in References 1, 2, and 3 are met. The core cooling function of the ECCS, along with the scram action of the RPS, ensures that the fuel peak cladding temperature remains below the limits of 10 CFR 50.46.

[5]
(Bypass)

[15]
[CS]

and one flow transmitter per LPCI subsystem are

When flow is low with the pump running

One flow transmitter per ECCS pump is used to detect the associated subsystems' flow rates. The logic is arranged such that each transmitter causes its associated minimum flow valve to open. The logic will close the minimum flow valve once the closure setpoint is exceeded. The LPCI minimum flow valves are time delayed such that the valves will not open for 10 seconds after the switches detect low flow. The time delay is provided to limit reactor vessel inventory loss during the startup of the RHR shutdown cooling mode. The Pump Discharge Flow—Low Allowable Values are high enough to ensure that the pump flow rate is sufficient to protect the pump, and low enough to ensure that the closure of the minimum flow valve is initiated to allow full flow into the core.

[5]
(Bypass)

The Core Spray Discharge Flow - Low (Bypass) Allowable Value is also

Each channel of Pump Discharge Flow—Low Function (two CS channels and four LPCI channels) is only required to be OPERABLE when the associated ECCS is required to be OPERABLE to ensure that no single instrument failure can preclude the ECCS function. Refer to LCO 3.5.1 and LCO 3.5.2 for Applicability Bases for the low pressure ECCS subsystems.

For LPCI, the closure of the minimum flow valves is not credited.

(continued)

BASES

APPLICABLE
SAFETY ANALYSES,
LCO, and
APPLICABILITY
(continued)

1.e. 2.h. Manual Initiation

The Manual Initiation push button channels introduce signals into the appropriate ECCS logic to provide manual initiation capability and are redundant to the automatic protective instrumentation. There is one push button for each of the CS and LPCI subsystems (i.e., two for CS and two for LPCI).

The Manual Initiation Function is not assumed in any accident or transient analyses in the FSAR. However, the Function is retained for overall redundancy and diversity of the low pressure ECCS function as required by the NRC in the plant licensing basis.

There is no Allowable Value for this Function since the channels are mechanically actuated based solely on the position of the push buttons. Each channel of the Manual Initiation Function (one channel per subsystem) is only required to be OPERABLE when the associated ECCS is required to be OPERABLE. Refer to LCO 3.5.1 and LCO 3.5.2 for Applicability Bases for the low pressure ECCS subsystems.

4

Insert from
Page B 3.3-114

4

2.d. Reactor Steam Dome Pressure—Low (Recirculation Discharge Valve Permissive)

Low reactor steam dome pressure signals are used as permissives for recirculation discharge valve closure. This ensures that the LPCI subsystems inject into the proper RPV location assumed in the safety analysis. The Reactor Steam Dome Pressure—Low is one of the Functions assumed to be OPERABLE and capable of closing the valve during the transients analyzed in References 1 and 3. The core cooling function of the ECCS, along with the scram action of the RPS, ensures that the fuel peak cladding temperature remains below the limits of 10 CFR 50.46. The Reactor Steam Dome Pressure—Low Function is directly assumed in the analysis of the recirculation line break (Ref. 2).

The Reactor Steam Dome Pressure—Low signals are initiated from four pressure transmitters that sense the reactor dome pressure.

The Allowable Value is chosen to ensure that the valves close prior to commencement of LPCI injection flow into the core, as assumed in the safety analysis.

4

Insert Function 2.d
and 2.f

4

(continued)

Insert Function 2.d and 2.i2.d. 2.i Reactor Steam Dome Pressure - Low (Break Detection) and Reactor Steam Dome Pressure Time Delay - Relay (Break Detection)

The purpose of the Reactor Steam Dome Pressure - Low (Break Detection) and Reactor Steam Dome Pressure Time Delay - Relay (Break Detection) Functions are to optimize the LPCI Loop Select Logic sensitivity if the logic previously actuated recirculation pump trips. This is accomplished by preventing the logic from continuing on to the unbroken loop selection activity until reactor steam dome pressure has dropped below a specified value. These Functions are only required to be OPERABLE for the DBA LOCA analysis, i.e., if the break location is in the recirculation system suction piping (Ref. 2). For a DBA LOCA, the analysis assumes that the LPCI Loop Select Logic successfully identifies and directs LPCI flow to the unbroken recirculation loop so that core reflooding is accomplished in time to ensure that the fuel peak cladding temperature remains below the limits of 10 CFR 50.46. For other LOCA events, (i.e., non-DBA recirculation system pipe breaks), or other RPV pipe breaks the success of the Loop Select Logic is less critical than for the DBA.

Reactor Steam Dome Pressure - Low (Break Detection) signals are initiated from four pressure switches that sense the reactor steam dome pressure. Reactor Steam Dome Pressure Time Delay - Relay (Break Detection) signals are initiated from two time delay relays.

The Reactor Steam Dome Pressure - Low (Break Detection) Allowable Value is chosen to allow for coastdown of any recirculation pump which has just tripped, this optimizes the sensitivity of the LPCI Loop Select Logic while ensuring that LPCI injection is not delayed. The Reactor Steam Dome Pressure Time Delay - Relay (Break Detection) Allowable Value is chosen to allow momentum effects to establish the maximum differential pressure for break detection.

Four channels of the Reactor Steam Dome Pressure - Low (Break Detection) Function and two channels of the Reactor Steam Dome Pressure Time Delay - Relay (Break Detection) Function are only required to be OPERABLE in MODES 1, 2, and 3 to ensure that no single failure can prevent the LPCI Loop Select Logic from successfully selecting the unbroken recirculation loop for LPCI injection. These Functions are not required to be OPERABLE in MODES 4 and 5 because, in those MODES, the loop for selection is controlled by plant operating procedures which ensure an OPERABLE LPCI flow path.

BASES

APPLICABLE
SAFETY ANALYSES,
LCO, and
APPLICABILITY

2.d. Reactor Steam Dome Pressure—Low (Recirculation Discharge Valve Permissive) (continued)

Four channels of the Reactor Steam Dome Pressure—Low Function are only required to be OPERABLE in MODES 1, 2, and 3 with the associated recirculation pump discharge valve open. With the valve(s) closed, the function instrumentation has been performed; thus, the Function is not required. In MODES 4 and 5, the loop injection location is not critical since LPCI injection through the recirculation loop in either direction will still ensure that LPCI flow reaches the core (i.e., there is no significant reactor steam dome back pressure).

4

2.e. Reactor Vessel Shroud Level—Level 0

The Level 0 Function is provided as a permissive to allow the RHR System to be manually aligned from the LPCI mode to the suppression pool cooling/spray or drywell spray modes. The permissive ensures that water in the vessel is approximately two thirds core height before the manual transfer is allowed. This ensures that LPCI is available to prevent or minimize fuel damage. This function may be overridden during accident conditions as allowed by plant procedures. Reactor Vessel Shroud Level—Level 0 Function is implicitly assumed in the analysis of the recirculation line break (Ref. 2) since the analysis assumes that no LPCI flow diversion occurs when reactor water level is below Level 0.

4

Reactor Vessel Shroud Level—Level 0 signals are initiated from two level transmitters that sense the difference between the pressure due to a constant column of water (reference leg) and the pressure due to the actual water level (variable leg) in the vessel. The Reactor Vessel Shroud Level—Level 0 Allowable Value is chosen to allow the low pressure core flooding systems to activate and provide adequate cooling before allowing a manual transfer.

Two channels of the Reactor Vessel Shroud Level—Level 0 Function are only required to be OPERABLE in MODES 1, 2, and 3. In MODES 4 and 5, the specified initiation time of the LPCI subsystems is not assumed, and other administrative controls are adequate to control the valves that this Function isolates (since the systems that the valves are

(continued)

move to page B 3.3-112 [4]
as indicated

All changes are [2] unless otherwise indicated

BASES

APPLICABLE SAFETY ANALYSES, LCO, and APPLICABILITY

2.e. Reactor Vessel Shroud Level—Level 0 (continued)
opened for are not required to be OPERABLE in MODES 4 and 5 and are normally not used).

2.f. Core Spray and Low Pressure Coolant Injection Pump Start—Time Delay Relay

The purpose of this time delay is to stagger the start of the LPCI pumps that are in each of Divisions 1 and 2, thus limiting the starting transients on the 4.16 kV emergency buses. This function is only necessary when power is being supplied from the standby power sources (DG). However, since the time delay does not degrade ECCS operation, it remains in the pump start logic at all times. The LPCI Pump Start—Time Delay Relays are assumed to be OPERABLE in the accident and transient analyses requiring ECCS initiation. That is, the analyses assume that the pumps will initiate when required and excess loading will not cause failure of the power sources.

i.e. [4]

CS and

160

ESS

CS and [4]

two CS Pump Start—Time Delay Relays and two

There are two LPCI Pump Start—Time Delay Relays, one for each of the RMR pump start logic circuits. While each time delay relay is dedicated to a single pump start logic, a single failure of a LPCI Pump Start—Time Delay Relay could result in the failure of the two low pressure ECCS pumps, powered on the same CS bus, to perform their intended function within the assumed ECCS RESPONSE TIME (e.g., as in the case where both ECCS pumps on one CS bus start simultaneously due to an inoperable time delay relay). This still leaves four of the six low pressure ECCS pumps OPERABLE; thus, the single failure criterion is met (i.e., loss of one instrument does not preclude ECCS initiation). The Allowable Value for the LPCI Pump Start—Time Delay Relays is chosen to be long enough so that most of the starting transient of the first pump is complete before starting the second pump on the same 4.16 kV emergency bus and short enough so that ECCS operation is not degraded.

for each CS pump

and one

three

ESS

for LPCI pump B and D

from

three

S

CS and

CS and

Each LPCI Pump Start—Time Delay Relay Function is required to be OPERABLE only when the associated LPCI subsystem is required to be OPERABLE. Refer to LCO 3.5.1 and LCO 3.5.2 for Applicability Bases for the LPCI subsystems.

CS and

← Insert Functions 2.g, 2.h, 2.i, and 2.k

(continued)

2 Insert Functions 2.g, 2.h, 2.i, and 2.k

2.g, 2.i Recirculation Pump Differential Pressure-High (Break Detection) and Recirculation Pump Differential Pressure Time Delay-Relay (Break Detection)

Recirculation Pump Differential Pressure signals are used by the LPCI Loop Select Logic to determine if either recirculation pump is running. If either pump is not running, i.e., Single Loop Operation, the logic, after a short time delay, sends a trip signal to both recirculation pumps. This is necessary to eliminate the possibility of small pipe breaks being masked by a running recirculation pump. These Functions are only required to be OPERABLE for the DBA LOCA analysis, i.e., if the break location is in the recirculation system suction piping (Ref. 2). For a DBA LOCA, the analysis assumes that the LPCI Loop Select Logic successfully identifies and directs LPCI flow to the unbroken recirculation loop so that core reflooding is accomplished in time to ensure that the fuel peak cladding temperature remains below the limits of 10 CFR 50.46. For other LOCA events (i.e., non-DBA recirculation system pipe breaks or other RPV pipe breaks), the success of the Loop Select Logic is less critical than for the DBA.

Recirculation Pump Differential Pressure-High (Break Detection) signals are initiated from eight differential pressure switches, four of which sense the pressure differential between the suction and discharge of each recirculation pump. Recirculation Pump Differential Pressure Time Delay-Relay (Break Detection) signals are initiated by two time delay relays.

The Recirculation Pump Differential Pressure-High (Break Detection) Allowable Value is chosen to be as low as possible, while still maintaining the ability to differentiate between a running and non-running recirculation pump. Recirculation Pump Differential Pressure Time Delay-Relay (Break Detection) Allowable Value is chosen to allow enough time to determine the status of the operating conditions of the recirculation pumps.

Eight channels of the Recirculation Pump Differential Pressure-High (Break Detection) Function and two channels of the Recirculation Pump Differential Pressure Time Delay-Relay (Break Detection) Function are only required to be OPERABLE in MODES 1, 2, and 3 to ensure that no single failure can prevent the LPCI Loop Select Logic from successfully determining if either recirculation pump is running. This Function is not required to be OPERABLE in MODES 4 and 5 because, in those MODES, the loop for selection is controlled by plant operating procedures which ensure an OPERABLE LPCI flow path.

2 Insert Functions 2.g, 2.h, 2.i, and 2.k (continued)

2.h, 2.k Recirculation Riser Differential Pressure-High (Break Detection) and Recirculation Riser Differential Pressure Time Delay-Relay (Break Detection)

Recirculation Riser Differential Pressure signals are used by the LPCI Loop Select Logic to determine which, if any, recirculation loop is broken. This is accomplished by comparing the pressure of the two recirculation loops. A broken loop will be indicated by a lower pressure than an unbroken loop. The loop with the higher pressure is then selected, after a short delay, for LPCI injection. If neither loop is broken, the logic defaults to injecting into the "B" recirculation loop. These Functions are only required to be OPERABLE for the DBA LOCA analysis, i.e., if the break location is in the recirculation system suction piping (Ref: 2). For a DBA LOCA, the analysis assumes that the LPCI Loop Select Logic successfully identifies and directs LPCI flow to the unbroken recirculation loop, the analysis assumes that the LPCI Loop Select Logic successfully identifies and directs LPCI flow to the unbroken recirculation loop so that core reflooding is accomplished in time to ensure that the fuel peak cladding temperature remains below the limits of 10 CFR 50.46. For other LOCA events, (i.e., non-DBA recirculation system pipe breaks), or other RPV pipe breaks, the success of the Loop Select Logic is less critical than for the DBA.

Recirculation Riser Differential Pressure-High (Break Detection) signals are initiated from four differential pressure switches that sense the pressure differential between the A recirculation loop riser and the B recirculation loop riser. If, after a small time delay, the pressure in loop A is not indicating higher than loop B pressure, the logic will select the B loop for injection. If recirculation loop A pressure is indicating higher than loop B pressure, the logic will select the A loop for LPCI injection. Recirculation Riser Differential Pressure Time Delay-Relay (Break Detection) signals are initiated by two time delay relays.

The Recirculation Riser Differential Pressure-High (Break Detection) Allowable Value is chosen to be as low as possible, while still maintaining the ability to differentiate between a broken and unbroken recirculation loop. The Recirculation Riser Differential Pressure Time Delay-Relay (Break Detection) Allowable Value is chosen to provide a sufficient amount of time to determine which loop is broken.

Four channels of the Recirculation Riser Differential Pressure-High (Break Detection) Function and two channels of the Recirculation Riser Differential Pressure Time Delay-Relay (Break Detection) Function are only required to be OPERABLE in MODES 1, 2, and 3 to ensure that no single failure can prevent the LPCI Loop Select Logic from successfully selecting the unbroken recirculation loop for LPCI injection. This Function is not required to be OPERABLE in MODES 4 and 5 because, in those MODES, the loop for selection is controlled by plant operating procedures which ensure an OPERABLE LPCI flow path.

All changes are unless otherwise indicated

BASES

APPLICABLE SAFETY ANALYSES, LCO, and APPLICABILITY (continued)

HPCI System

3.a. Reactor Vessel Water Level—Low Low Level 2 4

Low Low

Low RPV water level indicates that the capability to cool the fuel may be threatened. Should RPV water level decrease too far, fuel damage could result. Therefore, the HPCI System is initiated at Level 2 to maintain level above the top of the active fuel. The Reactor Vessel Water Level—Low Low Level 2 is one of the Functions assumed to be OPERABLE and capable of initiating HPCI during the transients analyzed in References 1 and 3. Additionally, the Reactor Vessel Water Level—Low Low Level 2 Function associated with HPCI is directly assumed in the analysis of the recirculation line break (Ref. 2). The core cooling function of the ECCS, along with the scram action of the RPS, ensures that the fuel peak cladding temperature remains below the limits of 10 CFR 50.46.

differential pressure switches

Reactor Vessel Water Level—Low Low Level 2 signals are initiated from four Level Transmitters that sense the difference between the pressure due to a constant column of water (reference leg) and the pressure due to the actual water level (variable leg) in the vessel.

maintain reactor vessel water level above the core

The Reactor Vessel Water Level—Low Low Level 2 Allowable Value is high enough such that for complete loss of feedwater flow, the Reactor Core Isolation Cooling (RCIC) System flow with HPCI assumed to fail will be sufficient to avoid initiation of low pressure ECCS at Reactor Vessel Water Level—Low Low Level 1.

Four channels of Reactor Vessel Water Level—Low Low Level 2 Function are required to be OPERABLE only when HPCI is required to be OPERABLE to ensure that no single instrument failure can preclude HPCI initiation. Refer to LCO 3.5.1 for HPCI Applicability Bases.

3.b. Drywell Pressure—High

High pressure in the drywell could indicate a break in the RCPB. The HPCI System is initiated upon receipt of the Drywell Pressure—High Function in order to minimize the possibility of fuel damage. The Drywell Pressure—High Function, along with the Reactor Water Level—Low Low Level 2 Function, is directly assumed in the analysis of ~~the~~

small break LOCA

(continued)

BASES

APPLICABLE SAFETY ANALYSES, LCO, and APPLICABILITY

3.b. Drywell Pressure—High (continued)

~~Recirculation line break~~ (Ref. 4). The core cooling function of the ECCS, along with the scram action of the RPS, ensures that the fuel peak cladding temperature remains below the limits of 10 CFR 50.46.

switches
2

High drywell pressure signals are initiated from four pressure transmitters that sense drywell pressure. The Allowable Value was selected to be as low as possible to be indicative of a LOCA inside primary containment.

Four channels of the Drywell Pressure—High Function are required to be OPERABLE when HPCI is required to be OPERABLE to ensure that no single instrument failure can preclude HPCI initiation. Refer to LCO 3.5.1 for the Applicability Bases for the HPCI System.

3.c. Reactor Vessel Water Level—High Level 8

Reactor Vessel Water Level—High Function
4

High RPV water level indicates that sufficient cooling water inventory exists in the reactor vessel such that there is no danger to the fuel. Therefore, the Level 8 signal is used to trip the HPCI turbine to prevent overflow into the main steam lines (MSLs). The Reactor Vessel Water Level—High Level 8 Function is not assumed in the accident and transient analyses. It was retained since it is a potentially significant contributor to risk.

plant specific
2

differential pressure switches
2

Reactor Vessel Water Level—High Level 8 signals for HPCI are initiated from two Level 8 transmitters from the narrow range water level measurement instrumentation. Both Level 8 signals are required in order to close the HPCI injection valve. This ensures that no single instrument failure can preclude HPCI initiation. The Reactor Vessel Water Level—High Level 8 Allowable Value is chosen to prevent flow from the HPCI System from overflowing into the MSLs.

Two channels of Reactor Vessel Water Level—High Level 8 Function are required to be OPERABLE only when HPCI is required to be OPERABLE. Refer to LCO 3.5.1 and LCO 3.5.2 for HPCI Applicability Bases.

(continued)

All changes are [2] unless otherwise indicated

BASES

APPLICABLE
SAFETY ANALYSES,
LCO, and
APPLICABILITY
(continued)

Contaminated

3.d. Condensate Storage Tank Level—Low

Low level in the CST indicates the unavailability of an adequate supply of makeup water from this normal source. Normally the suction valves between HPCI and the CST are open and, upon receiving a HPCI initiation signal, water for HPCI injection would be taken from the CST. However, if the water level in the CST falls below a preselected level, first the suppression pool suction valves automatically open, and then the CST suction valve automatically closes. This ensures that an adequate supply of makeup water is available to the HPCI pump. To prevent losing suction to the pump, the suction valves are interlocked so that the suppression pool suction valves must be open before the CST suction valve automatically closes. The function is implicitly assumed in the accident and transient analyses (which take credit for HPCI) since the analyses assume that the HPCI suction source is the suppression pool.

(two associated with each CCST)

Condensate Storage Tank Level—Low signals are initiated from level switches. The logic is arranged such that either level switch can cause the suppression pool suction valves to open and the CST suction valve to close. The Condensate Storage Tank Level—Low Function Allowable Value is high enough to ensure adequate pump suction head while water is being taken from the CST.

The output from these switches are provided to the logics of both HPCI Systems

Two channels of the Condensate Storage Tank Level—Low Function are required to be OPERABLE only when HPCI is required to be OPERABLE, to ensure that no single instrument failure can preclude HPCI swap to suppression pool source. Refer to LCO 3.5.1 for HPCI Applicability Bases.

and when both CCSTs are aligned to the HPCI system or two channels associated with the CCST aligned to HPCI when one CCST is isolated from the unit HPCI system. These requirements will

3.e. Suppression Pool Water Level—High

Excessively high suppression pool water could result in the loads on the suppression pool exceeding design values should there be a blowdown of the reactor vessel pressure through the safety relief valves. Therefore, signals indicating high suppression pool water level are used to transfer the suction source of HPCI from the CST to the suppression pool to eliminate the possibility of HPCI continuing to provide additional water from a source outside containment. To prevent losing suction to the pump, the suction valves are interlocked so that the suppression pool suction valves must be open before the CST suction valve automatically closes.

(continued)

BASES

APPLICABLE SAFETY ANALYSES, LCO, and APPLICABILITY

3.e. Suppression Pool Water Level—High (continued)

This Function is implicitly assumed in the accident and transient analyses (which take credit for HPCI) since the analyses assume that the HPCI suction source is the suppression pool.

Suppression Pool Water Level—High signals are initiated from two level switches. The logic is arranged such that either switch can cause the suppression pool suction valves to open and the CST suction valve to close. The Allowable Value for the Suppression Pool Water Level—High Function is chosen to ensure that HPCI will be aligned for suction from the suppression pool before the water level reaches the point at which suppression pool design loads would be exceeded.

Two channels of Suppression Pool Water Level—High Function are required to be OPERABLE only when HPCI is required to be OPERABLE to ensure that no single instrument failure can preclude HPCI swap to suppression pool source. Refer to LCO 3.5.1 for HPCI Applicability Bases.

3.f. High Pressure Coolant Injection Pump Discharge Flow—Low (Bypass)

The minimum flow instruments are provided to protect the HPCI pump from overheating when the pump is operating and the associated injection valve is not ~~fully~~ open. The minimum flow line valve is opened when low flow is sensed, and the valve is automatically closed when the flow rate is adequate to protect the pump. The High Pressure Coolant Injection Pump Discharge Flow—Low Function is assumed to be OPERABLE and capable of closing the minimum flow valve to ensure that the ECCS flow assumed during the transients and accidents analyzed in References 1, 2, and 3 are met. The core cooling function of the ECCS, along with the scram action of the RPS, ensures that the fuel peak cladding temperature remains below the limits of 10 CFR 50.46.

One ~~flow transmitter~~ is used to detect the HPCI System's flow rate. The logic is arranged such that the ~~transmitter~~ causes the minimum flow valve to open. The logic will close the minimum flow valve once the closure setpoint is exceeded.

4
The Allowable Value is confirmed by performance of a CHANNEL FUNCTIONAL TEST. This is acceptable since the design layout of the installation ensures the switches will trip at a level lower than the Allowable Value.

differential pressure switch
4

switch

(continued)

BASES

APPLICABLE
SAFETY ANALYSES,
LCO, and
APPLICABILITY

3.f. High Pressure Coolant Injection Pump Discharge Flow—Low (Bypass) (continued)

(Bypass) 5

The High Pressure Coolant Injection Pump Discharge Flow—Low Allowable Value is high enough to ensure that pump flow rate is sufficient to protect the pump, yet low enough to ensure that the closure of the minimum flow valve is initiated to allow full flow into the core. 2

One channel is required to be OPERABLE when the HPCI is required to be OPERABLE. Refer to LCO 3.5.1 for HPCI Applicability Bases.

3.g. Manual Initiation

The Manual Initiation push button channel introduces signals into the HPCI logic to provide manual initiation capability and is redundant to the automatic protective instrumentation. There is one push button for the HPCI System.

The Manual Initiation Function is not assumed in any accident or transient analyses in the FSAR. However, the Function is retained for overall redundancy and diversity of the HPCI function as required by the NRC in the plant licensing basis. 2

There is no Allowable Value for this Function since the channel is mechanically actuated based solely on the position of the push button. One channel of the Manual Initiation Function is required to be OPERABLE only when the HPCI System is required to be OPERABLE. Refer to LCO 3.5.1 for HPCI Applicability Bases.

Automatic Depressurization System

4.a. 5.a. Reactor Vessel Water Level—Low Low (Low Level)

4

Low RPV water level indicates that the capability to cool the fuel may be threatened. Should RPV water level decrease too far, fuel damage could result. Therefore, ADS receives one of the signals necessary for initiation from this Function. The Reactor Vessel Water Level—Low Low (Low Level) is one of the Functions assumed to be OPERABLE and capable of initiating the ADS during the accident analyzed. 4

(continued)

BASES

APPLICABLE
SAFETY ANALYSES,
LCO, and
APPLICABILITY

4.a. 5.a. Reactor Vessel Water Level—Low Low (Low Level 1)
(continued)

in Reference 2. The core cooling function of the ECCS, along with the scram action of the RPS, ensures that the fuel peak cladding temperature remains below the limits of 10 CFR 50.46.

differential pressure switches

2

Reactor Vessel Water Level—Low Low (Low Level 1) signals are initiated from four level transmitters that sense the difference between the pressure due to a constant column of water (reference leg) and the pressure due to the actual water level (variable leg) in the vessel. Four channels of Reactor Vessel Water Level—Low Low (Low Level 1) Function are required to be OPERABLE only when ADS is required to be OPERABLE to ensure that no single instrument failure can preclude ADS initiation. Two channels input to ADS trip system A, while the other two channels input to ADS trip system B. Refer to LCO 3.5.1 for ADS Applicability Bases.

4

4

The Reactor Vessel Water Level—Low Low (Low Level 1) Allowable Value is chosen to allow time for the low pressure core flooding systems to initiate and provide adequate cooling.

4

4.b. 5.b. Drywell Pressure—High

High pressure in the drywell could indicate a break in the RCPB. Therefore, ADS receives one of the signals necessary for initiation from this Function in order to minimize the possibility of fuel damage. The Drywell Pressure—High is assumed to be OPERABLE and capable of initiating the ADS during the accidents analyzed in Reference 2. The core cooling function of the ECCS, along with the scram action of the RPS, ensures that the fuel peak cladding temperature remains below the limits of 10 CFR 50.46.

switches

Drywell Pressure—High signals are initiated from four pressure transmitters that sense drywell pressure. The Allowable Value was selected to be as low as possible and be indicative of a LOCA inside primary containment.

2

Four channels of Drywell Pressure—High Function are only required to be OPERABLE when ADS is required to be OPERABLE to ensure that no single instrument failure can preclude ADS initiation. Two channels input to ADS trip system A, while

(continued)

BASES

**APPLICABLE
SAFETY ANALYSES,
LCO, and
APPLICABILITY**

4.b. 5.b. Drywell Pressure—High (continued)

the other two channels input to ADS trip system B. Refer to LCO 3.5.1 for ADS Applicability Bases.

4.c. 5.c. Automatic Depressurization System Initiation Timer

The purpose of the Automatic Depressurization System Initiation Timer is to delay depressurization of the reactor vessel to allow the HPCI System time to maintain reactor vessel water level. Since the rapid depressurization caused by ADS operation is one of the most severe transients on the reactor vessel, its occurrence should be limited. By delaying initiation of the ADS Function, the operator is given the chance to monitor the success or failure of the HPCI System to maintain water level, and then to decide whether or not to allow ADS to initiate, to delay initiation further by recycling the timer, or to inhibit initiation permanently. The Automatic Depressurization System Initiation Timer Function is assumed to be OPERABLE for the accident analyses of Reference 2 that require ECCS initiation and assume failure of the HPCI System.

There are two Automatic Depressurization System Initiation Timer relays, one in each of the two ADS trip systems. The Allowable Value for the Automatic Depressurization System Initiation Timer is chosen so that there is still time after depressurization for the low pressure ECCS subsystems to provide adequate core cooling.

Two channels of the Automatic Depressurization System Initiation Timer Function are only required to be OPERABLE when the ADS is required to be OPERABLE to ensure that no single instrument failure can preclude ADS initiation. One channel inputs to ADS trip system A, while the other channel inputs to ADS trip system B. Refer to LCO 3.5.1 for ADS Applicability Bases. [1]

4.d. 5.d. Reactor Vessel Water Level—Low, Level 3

The Reactor Vessel Water Level—Low, Level 3 Function is used by the ADS only as a confirmatory low water level signal. ADS receives one of the signals necessary for initiation from Reactor Vessel Water Level—Low Low Low, Level 1 signals. In order to prevent spurious initiation of [4]

(continued)

BASES

APPLICABLE
SAFETY ANALYSES,
LCO, and
APPLICABILITY

4.d. 5.d. Reactor Vessel Water Level—Low, Level 3
(continued)

the ADS due to spurious Level 1 signals, a Level 3 signal must also be received before ADS initiation commences.

Reactor Vessel Water Level—Low, Level 3 signals are initiated from two level transmitters that sense the difference between the pressure due to a constant column of water (reference leg) and the pressure due to the actual water level (variable leg) in the vessel. The Allowable Value for Reactor Vessel Water Level—Low, Level 3 is selected at the RPS Level 3 scram Allowable Value for convenience. Refer to LCO 3.3.1.1, "Reactor Protection System (RPS) Instrumentation," for the Bases discussion of this Function.

Two channels of Reactor Vessel Water Level—Low, Level 3 Function are only required to be OPERABLE when the ADS is required to be OPERABLE to ensure that no single instrument failure can preclude ADS initiation. One channel inputs to ADS trip system A, while the other channel inputs to ADS trip system B. Refer to LCO 3.5.1 for ADS Applicability Bases.

4

4.e. 4.f. 5.e. 5.f. Core Spray and Low Pressure Coolant Injection Pump Discharge Pressure—High

4

(indicating that the associated pump is running)

The Pump Discharge Pressure—High signals from the CS and LPCI pumps are used as permissives for ADS initiation, indicating that there is a source of low pressure cooling water available once the ADS has depressurized the vessel. Pump Discharge Pressure—High is one of the Functions assumed to be OPERABLE and capable of permitting ADS initiation during the events analyzed in Reference 2 with an assumed HPCI failure. For these events the ADS depressurizes the reactor vessel so that the low pressure ECCS can perform the core cooling functions. This core cooling function of the ECCS, along with the scram action of the RPS, ensures that the fuel peak cladding temperature remains below the limits of 10 CFR 50.46.

2

switches

Pump discharge pressure signals are initiated from twelve pressure transmitters, two on the discharge side of each of the six low pressure ECCS pumps. In order to generate an ADS permissive in one trip system, it is necessary that only

(continued)

BASES

d e d e

APPLICABLE SAFETY ANALYSES, LCO, and APPLICABILITY

4.0.4.0. 4.0.5.0. 5.0.4.0. 5.0.5.0. Core Spray and Low Pressure Coolant Injection Pump Discharge Pressure—High (continued)

4

one pump (both channels for the pump) indicate the high discharge pressure condition. The Pump Discharge Pressure—High Allowable Value is less than the pump discharge pressure when the pump is operating in a full flow mode and high enough to avoid any condition that results in a discharge pressure permissive when the CS and LPCI pumps are aligned for injection and the pumps are not running. The actual operating point of this function is not assumed in any transient or accident analysis.

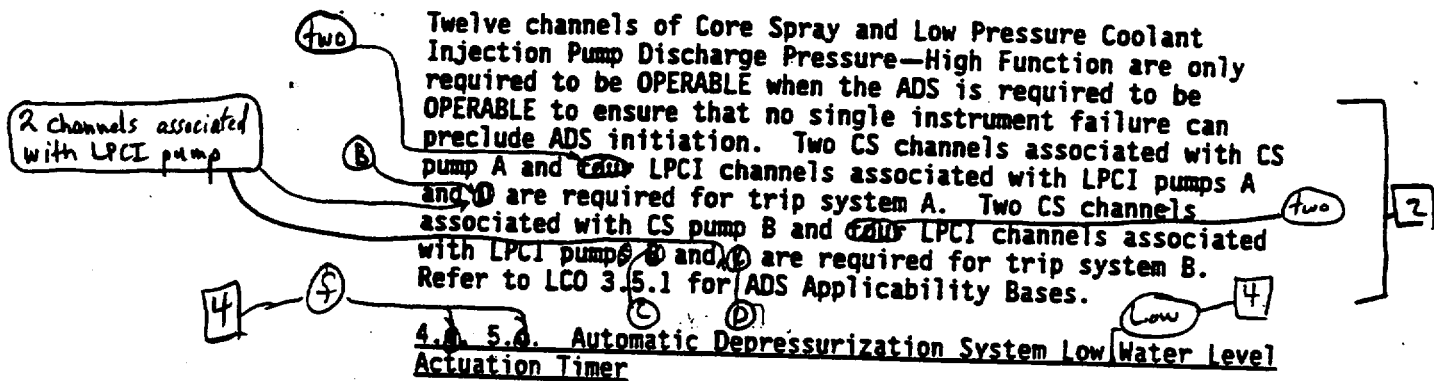

One of the signals required for ADS initiation is Drywell Pressure—High. However, if the event requiring ADS initiation occurs outside the drywell (e.g., main steam line break outside containment), a high drywell pressure signal may never be present. Therefore, the Automatic Depressurization System Low Water Level Actuation Timer is used to bypass the Drywell Pressure—High Function after a certain time period has elapsed. Operation of the Automatic Depressurization System Low Water Level Actuation Timer Function is not assumed in any accident analysis. The instrumentation is retained in the TS because ADS is part of the primary success path for mitigation of a DBA.

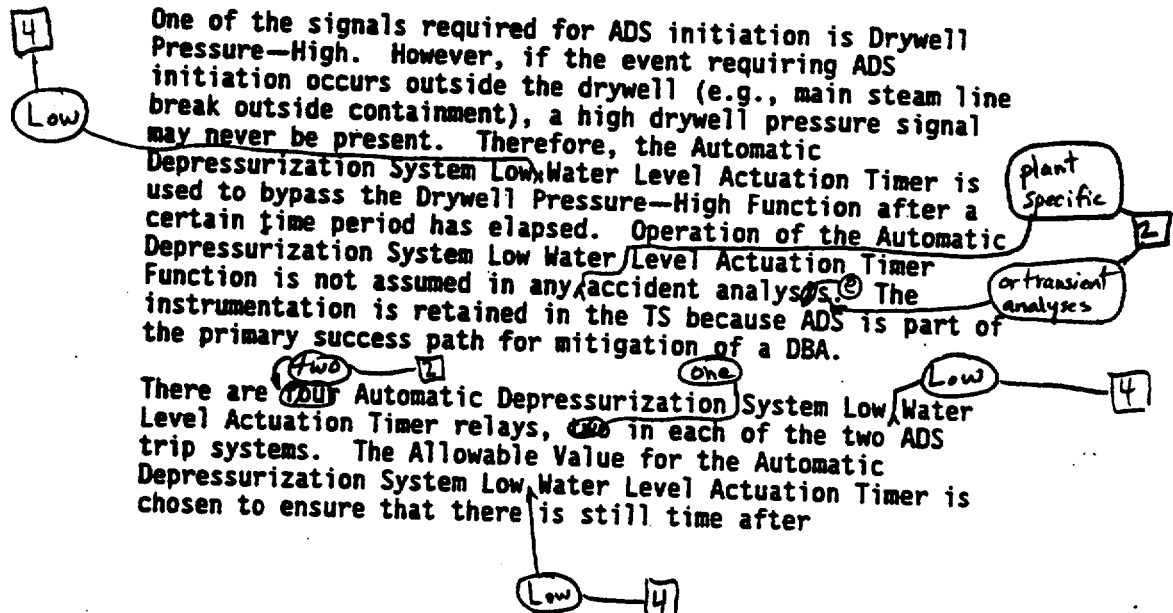

There are two Automatic Depressurization System Low Water Level Actuation Timer relays, one in each of the two ADS trip systems. The Allowable Value for the Automatic Depressurization System Low Water Level Actuation Timer is chosen to ensure that there is still time after

(continued)

BASES

APPLICABLE
SAFETY ANALYSES,
LCO, and
APPLICABILITY

4.g. 5.g. Automatic Depressurization System Low Water Level Actuation Timer (continued)

depressurization for the low pressure ECCS subsystems to provide adequate core cooling.

Two
2

FOUR channels of the Automatic Depressurization System Low Water Level Actuation Timer Function are only required to be OPERABLE when the ADS is required to be OPERABLE to ensure that no single instrument failure can preclude ADS initiation. Refer to LCO 3.5.1 for ADS Applicability Bases.

4.h. 5.h. Manual Initiation

The Manual Initiation push button channels introduce signals into the ADS logic to provide manual initiation capability and are redundant to the automatic protective instrumentation. There are two push buttons for each ADS trip system for a total of four.

The Manual Initiation Function is not assumed in any accident or transient analyses in the FSAR. However, the Function is retained for overall redundancy and diversity of the ADS functions as required by the NRC in the plant licensing basis.

There is no Allowable Value for this Function since the channels are mechanically actuated based solely on the position of the push buttons. Four channels of the Manual Initiation Function (two channels per trip system) are only required to be OPERABLE when the ADS is required to be OPERABLE. Refer to LCO 3.5.1 for ADS Applicability Bases.

ACTIONS

Reviewer's Note: Certain LCO Completion Times are based on approved topical reports. In order for a licensee to use the times, the licensee must justify the Completion Times as required by the staff Safety Evaluation Report (SER) for the topical report.

A Note has been provided to modify the ACTIONS related to ECCS instrumentation channels. Section 1.3, Completion Times, specifies that once a Condition has been entered, subsequent divisions, subsystems, components, or variables expressed in the Condition discovered to be inoperable or

(continued)

BASES

ACTIONS
(continued)

not within limits will not result in separate entry into the Condition. Section 1.3 also specifies that Required Actions of the Condition continue to apply for each additional failure, with Completion Times based on initial entry into the Condition. However, the Required Actions for inoperable ECCS instrumentation channels provide appropriate compensatory measures for separate inoperable Condition entry for each inoperable ECCS instrumentation channel.

A.1

4
required

Required Action A.1 directs entry into the appropriate Condition referenced in Table 3.3.5.1-1. The applicable Condition referenced in the table is Function dependent. Each time a channel is discovered inoperable, Condition A is entered for that channel and provides for transfer to the appropriate subsequent Condition.

B.1, B.2, and B.3

variable 1

and associated DG

i.e.

Required Actions B.1 and B.2 are intended to ensure that appropriate actions are taken if multiple, inoperable, untripped channels within the same function result in redundant automatic initiation capability being lost for the feature(s). Required Action B.1 features would be those that are initiated by Functions 1.a, 1.b, 2.a, ~~2.b~~ 2.b (e.g., low pressure ECCS). The Required Action B.2 system would be HPCI. For Required Action B.1, redundant automatic initiation capability is lost if (a) two Function 1.a channels are inoperable and untripped in the same trip system, (b) two Function 2.a channels are inoperable and untripped in the same trip system, (c) two Function 1.b channels are inoperable and untripped in the same system, or (d) two Function 2.b channels are inoperable and untripped in the same trip system. For low pressure ECCS, since each inoperable channel would have Required Action B.1 applied separately (refer to ACTIONS Note), each inoperable channel would only require the affected portion of the associated system of low pressure ECCS and DGs to be declared inoperable. However, since channels in both associated low pressure ECCS subsystems (e.g., both CS subsystems) are inoperable and untripped, and the Completion Times started concurrently for the channels in both subsystems, this results in the affected portions in the associated low

2.d and 2.e

2

Insert Action B.1

(continued)

2

Insert B.1

(a) two or more Function 1.a channels are inoperable and untripped such that both trip systems lose initiation capability, (b) two or more Function 2.a channels are inoperable and untripped such that both trip systems lose initiation capability, (c) two or more Function 1.b channels are inoperable and untripped such that both trip systems lose initiation capability, (d) two or more Function 2.b channels are inoperable and untripped such that both trip systems lose initiation capability. (e) two or more Function 2.d channels are inoperable and untripped such that both trip systems lose initiation capability, or (f) two Function 2.j channels are inoperable and untripped.

BASES

ACTIONS

B.1, B.2, and B.3 (continued)

pressure ECCS and DGs being concurrently declared inoperable.

(i.e., loss of automatic start capability for Functions 3.a and 3.b)

For Required Action B.2, redundant automatic initiation capability is lost if two Function 3.a or two Function 3.b channels are inoperable and untripped in the same trip system. In this situation (loss of redundant automatic initiation capability), the 24 hour allowance of Required Action B.3 is not appropriate and the feature(s) associated with the inoperable, untripped channels must be declared inoperable within 1 hour. As noted (Note 1 to Required Action B.1), Required Action B.1 is only applicable in MODES 1, 2, and 3. In MODES 4 and 5, the specific initiation time of the low pressure ECCS is not assumed and the probability of a LOCA is lower. Thus, a total loss of initiation capability for 24 hours (as allowed by Required Action B.3) is allowed during MODES 4 and 5. There is no similar Note provided for Required Action B.2 since HPCI instrumentation is not required in MODES 4 and 5; thus, a Note is not necessary.

Notes are also provided (Note 2 to Required Action B.1 and the Note to Required Action B.2) to delineate which Required Action is applicable for each Function that requires entry into Condition B if an associated channel is inoperable. This ensures that the proper loss of initiation capability check is performed. Required Action B.1 (the Required Action for certain inoperable channels in the low pressure ECCS subsystems) is not applicable to Function 2.e since this Function provides backup to administrative controls ensuring that operators do not divert LPCI flow from injecting into the core when needed. Thus, a total loss of Function 2.e capability for 24 hours is allowed, since the LPCI subsystems remain capable of performing their intended function.

The Completion Time is intended to allow the operator time to evaluate and repair any discovered inoperabilities. This Completion Time also allows for an exception to the normal "time zero" for beginning the allowed outage time "clock." For Required Action B.1, the Completion Time only begins upon discovery that a redundant feature in the same system (e.g., both CS subsystems) cannot be automatically initiated due to inoperable, untripped channels within the same

(continued)

BASES

ACTIONS

B.1, B.2, and B.3 (continued)

1
variable

Function as described in the paragraph above. For Required Action B.2, the Completion Time only begins upon discovery that the HPCI System cannot be automatically initiated due to two inoperable, untripped channels for the associated ~~Function~~ in the same trip system. The 1 hour Completion Time from discovery of loss of initiation capability is acceptable because it minimizes risk while allowing time for restoration or tripping of channels.

4

Because of the diversity of sensors available to provide initiation signals and the redundancy of the ECCS design, an allowable out of service time of 24 hours has been shown to be acceptable (Ref. 3) to permit restoration of any inoperable channel to OPERABLE status. If the inoperable channel cannot be restored to OPERABLE status within the allowable out of service time, the channel must be placed in the tripped condition per Required Action B.3. Placing the inoperable channel in trip would conservatively compensate for the inoperability, restore capability to accommodate a single failure, and allow operation to continue. Alternately, if it is not desired to place the channel in trip (e.g., as in the case where placing the inoperable channel in trip would result in an initiation), Condition H must be entered and its Required Action taken.

2

1
variable

C.1 and C.2

Required Action C.1 is intended to ensure that appropriate actions are taken if multiple, inoperable channels within the same ~~Function~~ result in redundant automatic initiation capability being lost for the feature(s). Required Action C.1 features would be those that are initiated by Functions 1.c, 2.c, ~~2.d~~, and 2.f (i.e., low pressure ECCS). Redundant automatic initiation capability is lost if either

2.e, 2.g, 2.h, 2.i

4
1.e

(a) two Function 1.c channels are inoperable in the same trip system, (b) two Function 2.c channels are inoperable in the same trip system, (c) two Function 2.d channels are inoperable in the same trip system, or (d) two or more Function 2.f channels are inoperable. In this situation (loss of redundant automatic initiation capability), the 24 hour allowance of Required Action C.2 is not appropriate and the feature(s) associated with the inoperable channels must be declared inoperable within 1 hour. Since each

Insert C.1
2

Insert text from page B 3.3-12B as indicated

(continued)

1

2

Insert C.1

(a) two Function 1.c channels are inoperable in both trip systems, (b) two Function 2.c channels are inoperable in both trip systems, (c) two Function 1.e channels are inoperable, (d) two Function 2.e channels are inoperable, (e) two or more Function 2.g channels, associated with a recirculation pump are inoperable such that both trip systems lose initiation capability, (f) two or more Function 2.h channels are inoperable such that both trip systems lose initiation capability, (g) two Function 2.i channels are inoperable, or (h) two Function 2.k channels are inoperable.

BASES

ACTIONS

C.1 and C.2 (continued)

move to page
B 3.3-127 as
indicated

For Functions 1.c and 2.c, the affected portions are the associated ECCS pumps and valves. For Functions 2.g, 2.h, 2.i, and 2.j, the affected portions are the associated LPCI values

inoperable channel would have Required Action C.1 applied separately (refer to ACTIONS Note), each inoperable channel would only require the affected portion of the associated system to be declared inoperable. However, since channels for both low pressure ECCS subsystems are inoperable (e.g., both CS subsystems), and the Completion Times started concurrently for the channels in both subsystems, this results in the affected portions in both subsystems being concurrently declared inoperable. For Functions 1.c, 2.a, and 2.d, the affected portions are the associated low pressure ECCS pumps. As noted (Note 1), Required Action C.1 is only applicable in MODES 1, 2, and 3. In MODES 4 and 5, the specific initiation time of the ECCS is not assumed and the probability of a LOCA is lower. Thus, a total loss of automatic initiation capability for 24 hours (as allowed by Required Action C.2) is allowed during MODES 4 and 5.

Note 2 states that Required Action C.1 is only applicable for Functions 1.c, 2.c, 2.d, and 2.e. Required Action C.1 is not applicable to Functions 2.g, 2.h, and 3.g (which also require entry into this Condition if a channel in these Function is inoperable), since they are the Manual Initiation Functions and are not assumed in any accident or transient analysis. Thus, a total loss of manual initiation capability for 24 hours (as allowed by Required Action C.2) is allowed. Required Action C.1 is also not applicable to Function 3.c (which also requires entry into this Condition if a channel in this Function is inoperable), since the loss of one channel results in a loss of the Function (two-out-of-two logic). This loss was considered during the development of Reference 6 and considered acceptable for the 24 hours allowed by Required Action C.2.

The Completion Time is intended to allow the operator time to evaluate and repair any discovered inoperabilities. This Completion Time also allows for an exception to the normal "time zero" for beginning the allowed outage time "clock." For Required Action C.1, the Completion Time only begins upon discovery that the same feature in both subsystems (e.g., both CS subsystems) cannot be automatically initiated due to inoperable channels within the same function as described in the paragraph above. The 1 hour Completion Time from discovery of loss of initiation capability is

Variable
2

(continued)

BASES

ACTIONS

C.1 and C.2 (continued)

acceptable because it minimizes risk while allowing time for restoration of channels.

2

4

Because of the diversity of sensors available to provide initiation signals and the redundancy of the ECCS design, an allowable out of service time of 24 hours has been shown to be acceptable (Ref. 5) to permit restoration of any inoperable channel to OPERABLE status. If the inoperable channel cannot be restored to OPERABLE status within the allowable out of service time, Condition H must be entered and its Required Action taken. The Required Actions do not allow placing the channel in trip since this action would either cause the initiation or it would not necessarily result in a safe state for the channel in all events.

2

If both CCSTs are available, HPCI automatic initiation capability is lost if four Function 3.d channels (2 of the required channels) are inoperable and untripped. If one CCST is not available, automatic initiation capability is lost if two channels associated with the other CCST are inoperable and untripped.

D.1, D.2.1, and D.2.2

HPCI

2

Required Action D.1 is intended to ensure that appropriate actions are taken if multiple, inoperable, untripped channels within the same Function result in a complete loss of automatic component initiation capability for the HPCI System. Automatic component initiation capability is lost if two Function 3.d channels or two Function 3.e channels are inoperable and untripped. In this situation (loss of automatic suction swap), the 24 hour allowance of Required Actions D.2.1 and D.2.2 is not appropriate and the HPCI System must be declared inoperable within 1 hour after discovery of loss of HPCI initiation capability. As noted, Required Action D.1 is only applicable if the HPCI pump suction is not aligned to the suppression pool, since, if aligned, the Function is already performed.

The Completion Time is intended to allow the operator time to evaluate and repair any discovered inoperabilities. This Completion Time also allows for an exception to the normal "time zero" for beginning the allowed outage time "clock." For Required Action D.1, the Completion Time only begins upon discovery that the HPCI System cannot be automatically aligned to the suppression pool due to two inoperable, untripped channels in the same Function. The 1 hour Completion Time from discovery of loss of initiation capability is acceptable because it minimizes risk while allowing time for restoration or tripping of channels.

(continued)

BASES

ACTIONS

D.1, D.2.1, and D.2.2 (continued)

(4) Because of the diversity of sensors available to provide initiation signals and the redundancy of the ECCS design, an allowable out of service time of 24 hours has been shown to be acceptable (Ref. (4)) to permit restoration of any inoperable channel to OPERABLE status. If the inoperable channel cannot be restored to OPERABLE status within the allowable out of service time, the channel must be placed in the tripped condition per Required Action D.2.1 or the suction source must be aligned to the suppression pool per Required Action D.2.2. Placing the inoperable channel in trip performs the intended function of the channel (shifting the suction source to the suppression pool). Performance of either of these two Required Actions will allow operation to continue. If Required Action D.2.1 or D.2.2 is performed, measures should be taken to ensure that the HPCI System piping remains filled with water. Alternately, if it is not desired to perform Required Actions D.2.1 and D.2.2 (e.g., as in the case where shifting the suction source could drain down the HPCI suction piping), Condition H must be entered and its Required Action taken.]-2

E.1 and E.2

Required Action E.1 is intended to ensure that appropriate actions are taken if multiple, inoperable channels within the Core Spray and Low Pressure Coolant Injection Pump Discharge Flow—Low (Bypass) Functions result in redundant automatic initiation capability being lost for the feature(s). For Required Action E.1, the features would be those that are initiated by Functions 1.d and 2.g (e.g., low pressure ECCS). Redundant automatic initiation capability is lost if (a) two Function 1.d channels are inoperable or (b) one or more Function 2.g channels associated with pumps in LPCI subsystem A and one or more Function 2.g channels associated with pumps in LPCI subsystem B are inoperable. Since each inoperable channel would have Required Action E.1 applied separately (refer to ACTIONS Note), each inoperable channel would only require the affected low pressure ECCS pump to be declared inoperable. However, since channels for more than one low pressure ECCS pump are inoperable, and the Completion Times started concurrently for the channels of the low pressure ECCS pumps, this results in the affected

(b) two Function 2.f channels are inoperable

(f)]-2
(ie)]-4

(continued)

BASES

ACTIONS

E.1 and E.2 (continued)

low pressure ECCS pumps being concurrently declared inoperable.

In this situation (loss of redundant automatic initiation capability), the 7 day allowance of Required Action E.2 is not appropriate and the subsystem associated with each inoperable channel must be declared inoperable within 1 hour. As noted (Note 1 to Required Action E.1), Required Action E.1 is only applicable in MODES 1, 2, and 3. In MODES 4 and 5, the specific initiation time of the ECCS is not assumed and the probability of a LOCA is lower. Thus, a total loss of initiation capability for 7 days (as allowed by Required Action E.2) is allowed during MODES 4 and 5. A Note is also provided (Note 2 to Required Action E.1) to delineate that Required Action E.1 is only applicable to low pressure ECCS Functions. Required Action E.1 is not applicable to HPCI Function 3.f since the loss of one channel results in a loss of the Function (one-out-of-one logic). This loss was considered during the development of Reference ④ and considered acceptable for the 7 days allowed by Required Action E.2.] [2]

The Completion Time is intended to allow the operator time to evaluate and repair any discovered inoperabilities. This Completion Time also allows for an exception to the normal "time zero" for beginning the allowed outage time "clock."

① For Required Action E.1, the Completion Time only begins upon discovery that a redundant feature in the same system (e.g., both CS subsystems) cannot be automatically initiated due to inoperable channels within the same Function as described in the paragraph above. The 1 hour Completion Time from discovery of loss of initiation capability is acceptable because it minimizes risk while allowing time for restoration of channels.

If the instrumentation that controls the pump minimum flow valve is inoperable, such that the valve will not automatically open, extended pump operation with no injection path available could lead to pump overheating and failure. If there were a failure of the instrumentation, such that the valve would not automatically close, a portion of the pump flow could be diverted from the reactor vessel injection path, causing insufficient core cooling. These

Core Spray

2

The low pressure coolant injection minimum flow control valve is assumed to remain open during injection

(continued)

BASES

ACTIONS

E.1 and E.2 (continued)

consequences can be averted by the operator's manual control of the valve, which would be adequate to maintain ECCS pump protection and required flow. Furthermore, other ECCS pumps would be sufficient to complete the assumed safety function if no additional single failure were to occur. The 7 day Completion Time of Required Action E.2 to restore the inoperable channel to OPERABLE status is reasonable based on the remaining capability of the associated ECCS subsystems, the redundancy available in the ECCS design, and the low probability of a DBA occurring during the allowed out of service time. If the inoperable channel cannot be restored to OPERABLE status within the allowable out of service time, Condition H must be entered and its Required Action taken. The Required Actions do not allow placing the channel in trip since this action would not necessarily result in a safe state for the channel in all events.

F.1 and F.2

Required Action F.1 is intended to ensure that appropriate actions are taken if multiple, inoperable, untripped channels within similar ADS trip system A and B Functions result in redundant automatic initiation capability being lost for the ADS. Redundant automatic initiation capability is lost if either (a) one Function 4.a channel, and one Function 5.a channel, are inoperable and untripped, (b) one Function 4.b channel, and one Function 5.b channel, are inoperable and untripped, or (c) one Function 4.d channel, and one Function 5.d channel, are inoperable and untripped.

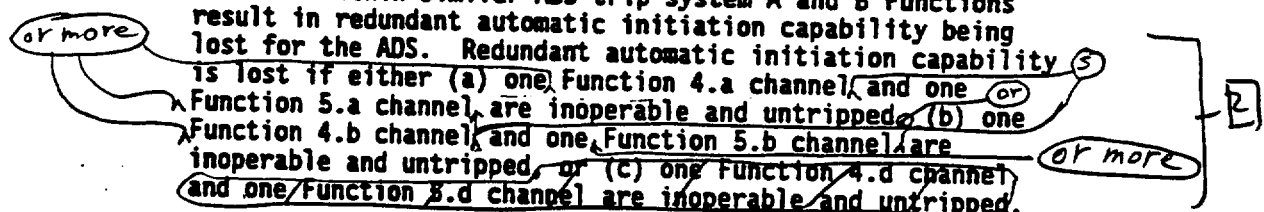

In this situation (loss of automatic initiation capability), the 96 hour or 8 day allowance, as applicable, of Required Action F.2 is not appropriate and all ADS valves must be declared inoperable within 1 hour after discovery of loss of ADS initiation capability.

The Completion Time is intended to allow the operator time to evaluate and repair any discovered inoperabilities. This Completion Time also allows for an exception to the normal "time zero" for beginning the allowed outage time "clock." For Required Action F.1, the Completion Time only begins upon discovery that the ADS cannot be automatically initiated due to inoperable, untripped channels within

(continued)

BASES

ACTIONS

F.1 and F.2 (continued)

similar ADS trip system Functions as described in the paragraph above. The 1 hour Completion Time from discovery of loss of initiation capability is acceptable because it minimizes risk while allowing time for restoration or tripping of channels.

④ Because of the diversity of sensors available to provide initiation signals and the redundancy of the ECCS design, an allowable out of service time of 8 days has been shown to be acceptable (Ref. ⑤) to permit restoration of any inoperable channel to OPERABLE status if both HPCI and RCIC are OPERABLE. If either HPCI or RCIC is inoperable, the time is shortened to 96 hours. If the status of HPCI or RCIC changes such that the Completion Time changes from 8 days to 96 hours, the 96 hours begins upon discovery of HPCI or RCIC inoperability. However, the total time for an inoperable, untripped channel cannot exceed 8 days. If the status of HPCI or RCIC changes such that the Completion Time changes from 96 hours to 8 days, the "time zero" for beginning the 8 day "clock" begins upon discovery of the inoperable, untripped channel. If the inoperable channel cannot be restored to OPERABLE status within the allowable out of service time, the channel must be placed in the tripped condition per Required Action F.2. Placing the inoperable channel in trip would conservatively compensate for the inoperability, restore capability to accommodate a single failure, and allow operation to continue. Alternately, if it is not desired to place the channel in trip (e.g., as in the case where placing the inoperable channel in trip would result in an initiation), Condition H must be entered and its Required Action taken.

②

G.1 and G.2

Required Action G.1 is intended to ensure that appropriate actions are taken if multiple, inoperable channels within similar ADS trip system Functions result in automatic initiation capability being lost for the ADS. Automatic initiation capability is lost if either (a) one Function 4.c channel and one Function 5.c channel are inoperable, (b) a combination of Function 4.⑥, 4.⑦, 5.⑥, and 5.⑦ channels are inoperable such that channels associated with five or more low pressure ECCS pumps are inoperable, or (c) one ~~of more~~

⑤
④
②
④
④
④

(continued)

BASES

ACTIONS

G.1 and G.2 (continued)

Function 4.ⓐ channelⓐ and one ~~or more~~ Function 5.g channelⓐ are inoperable. [2]
[4]

In this situation (loss of automatic initiation capability), the 96 hour or 8 day allowance, as applicable, of Required Action G.2 is not appropriate, and all ADS valves must be declared inoperable within 1 hour after discovery of loss of ADS initiation capability. ~~The Note to Required Action G.1 states that Required Action G.1 is only applicable for Functions 4.c, 4.e, 4.f, 4.g, 5.c, 5.e, 5.f, and 5.g. Required Action G.1 is not applicable to Functions 4.h and 5.h (which also require entry into this Condition if a channel in these Functions is inoperable), since they are the Manual Initiation Functions and are not assumed in any accident or transient analysis. Thus, a total loss of manual initiation capability for 96 hours or 8 days (as allowed by Required Action G.2) is allowed.~~ [4]

The Completion Time is intended to allow the operator time to evaluate and repair any discovered inoperabilities. This Completion Time also allows for an exception to the normal "time zero" for beginning the allowed outage time "clock." For Required Action G.1, the Completion Time only begins upon discovery that the ADS cannot be automatically initiated due to inoperable channels within similar ADS trip system Functions as described in the paragraph above. The 1 hour Completion Time from discovery of loss of initiation capability is acceptable because it minimizes risk while allowing time for restoration or tripping of channels.

④ Because of the diversity of sensors available to provide initiation signals and the redundancy of the ECCS design, an allowable out of service time of 8 days has been shown to be acceptable (Ref. ⑤) to permit restoration of any inoperable channel to OPERABLE status if both HPCI and RCIC are OPERABLE (Required Action G.2). If either HPCI or RCIC is inoperable, the time shortens to 96 hours. If the status of HPCI or RCIC changes such that the Completion Time changes from 8 days to 96 hours, the 96 hours begins upon discovery of HPCI or RCIC inoperability. However, the total time for an inoperable channel cannot exceed 8 days. If the status of HPCI or RCIC changes such that the Completion Time changes from 96 hours to 8 days, the "time zero" for beginning the 8 day "clock" begins upon discovery of the [2]

(continued)

BASES

ACTIONS

G.1 and G.2 (continued)

inoperable channel. If the inoperable channel cannot be restored to OPERABLE status within the allowable out of service time, Condition H must be entered and its Required Action taken. The Required Actions do not allow placing the channel in trip since this action would not necessarily result in a safe state for the channel in all events.

H.1

With any Required Action and associated Completion Time not met, the associated feature(s) may be incapable of performing the intended function, and the supported feature(s) associated with inoperable untripped channels must be declared inoperable immediately.

**SURVEILLANCE
REQUIREMENTS**

Reviewer's Note: Certain Frequencies are based on approved topical reports. In order for a licensee to use these Frequencies, the licensee must justify the Frequencies as required by the staff SER for the topical report. 6

As noted in the beginning of the SRs, the SRs for each ECCS instrumentation Function are found in the SRs column of Table 3.3.5.1-1.

The Surveillances are modified by a Note to indicate that when a channel is placed in an inoperable status solely for performance of required Surveillances, entry into associated Conditions and Required Actions may be delayed for up to 6 hours as follows: (a) for Functions 3.c, 3.f, and 3.g; and (b) for Functions other than 3.c, 3.f, and 3.g provided the associated Function or redundant Function maintains ECCS initiation capability. Upon completion of the Surveillance, or expiration of the 6 hour allowance, the channel must be returned to OPERABLE status or the applicable Condition entered and Required Actions taken. This Note is based on the reliability analysis (Ref. 4) assumption of the average time required to perform channel surveillance. That analysis demonstrated that the 6 hour testing allowance does not significantly reduce the probability that the ECCS will initiate when necessary. 4 2

(continued)

BASES

SURVEILLANCE
REQUIREMENTS
(continued)

SR 3.3.5.1.1

Performance of the CHANNEL CHECK once every 12 hours ensures that a gross failure of instrumentation has not occurred. A CHANNEL CHECK is normally a comparison of the parameter indicated on one channel to a similar parameter on other channels. It is based on the assumption that instrument channels monitoring the same parameter should read approximately the same value. Significant deviations between the instrument channels could be an indication of excessive instrument drift in one of the channels or something even more serious. A CHANNEL CHECK guarantees that undetected outright channel failure is limited to 12 hours; thus, it is key to verifying the instrumentation continues to operate properly between each CHANNEL CALIBRATION.

Agreement criteria are determined by the plant staff, based on a combination of the channel instrument uncertainties, including indication and readability. If a channel is outside the criteria, it may be an indication that the instrument has drifted outside its limit.

The Frequency is based upon operating experience that demonstrates channel failure is rare. The CHANNEL CHECK supplements less formal, but more frequent, checks of channels during normal operational use of the displays associated with the channels required by the LCO.

SR 3.3.5.1.2

and SR 3.3.5.1.4 (4)

A CHANNEL FUNCTIONAL TEST is performed on each required channel to ensure that the ~~entire~~ channel will perform the intended function.

Any setpoint adjustment shall be consistent with the assumptions of the current plant specific setpoint methodology.

The Frequency of 92 days is based on the reliability analyses of Reference (4)

of 31 days for SR 3.3.5.1.2 is based on engineering judgement and the reliability of the equipment. The Frequency

for SR 3.3.5.1.4

(continued)

BASES

SURVEILLANCE REQUIREMENTS
(continued)

SR 3.3.5.1.3 ⑤

Calibration of trip units provides a check of the actual trip setpoints. The channel must be declared inoperable if the trip setting is discovered to be less conservative than the Allowable Value specified in Table 3.3.5.1-1. If the trip setting is discovered to be less conservative than accounted for in the appropriate setpoint methodology, but is not beyond the Allowable Value, the channel performance is still within the requirements of the plant safety analyses. Under these conditions, the setpoint must be readjusted to be equal to or more conservative than the setting accounted for in the appropriate setpoint methodology.

The Frequency of 92 days is based on the reliability analysis of Reference ④.

SR 3.3.5.1.4 and SR 3.3.5.1.5

A CHANNEL CALIBRATION is a complete check of the instrument loop and the sensor. This test verifies the channel responds to the measured parameter within the necessary range and accuracy. CHANNEL CALIBRATION leaves the channel adjusted to account for instrument drifts between successive calibrations consistent with the plant specific setpoint methodology.

The Frequency of SR 3.3.5.1.4 is based upon the assumption of a 92 day calibration interval in the determination of the magnitude of equipment drift in the setpoint analysis.

The Frequency of SR 3.3.5.1.5 is based upon the assumption of a 24 month calibration interval in the determination of the magnitude of equipment drift in the setpoint analysis.

SR 3.3.5.1.6 ② ④

The LOGIC SYSTEM FUNCTIONAL TEST demonstrates the OPERABILITY of the required initiation logic for a specific channel. The system functional testing performed in LCO 3.5.1, LCO 3.5.2, LCO 3.8.1, and LCO 3.8.2 overlaps this Surveillance to complete testing of the assumed safety function.

provide ③

The Frequency of SR 3.3.5.1.3 is based upon the assumption of a 60 day calibration interval in the determination of the magnitude of equipment drift in the setpoint analysis.

(continued)

BASES

SURVEILLANCE
REQUIREMENTS

SR 3.3.5.1.6 (continued)

The 18 month Frequency is based on the need to perform this Surveillance under the conditions that apply during a plant outage and the potential for an unplanned transient if the Surveillance were performed with the reactor at power. Operating experience has shown that these components usually pass the Surveillance when performed at the 18 month Frequency.

SR 3.3.5.1.7

This SR ensures that the individual channel response times are less than or equal to the maximum values assumed in the accident analysis. Response time testing acceptance criteria are included in Reference 4.

ECCS RESPONSE TIME tests are conducted on an 18 month STAGGERED TEST BASIS. The 18 month Frequency is consistent with the typical industry refueling cycle and is based upon plant operating experience, which shows that random failures of instrumentation components causing serious response time degradation, but not channel failure, are infrequent occurrences.

REFERENCES

1. FSAR, Section 5.2.
2. FSAR, Section 6.3.
3. FSAR, Chapter 15.
4. NEDC-31376-P, "Edwin I. Hatch Nuclear Power Plant, SAFER/GESTR-LOCA, Loss-of-Coolant Accident Analysis," December 1986.
5. NEDC-30936-P-A, "BWR Owners' Group Technical Specification Improvement Analyses for ECCS Actuation Instrumentation, Part 2," December 1988.

Part 1 and

JUSTIFICATION FOR DEVIATIONS FROM NUREG-1433, REVISION 1
ITS BASES: 3.3.5.1 - ECCS INSTRUMENTATION

1. Editorial changes made for enhanced clarity or to be consistent with similar statements in other places in the Bases.
2. Changes have been made (additions, deletions, and/or changes to the NUREG) to reflect the plant specific methodology, nomenclature, number, reference, system description, analysis description, or licensing basis description.
3. Typographical/grammatical error corrected.
4. Changes have been made to reflect those changes made to the Specification. The following requirements have been renumbered, where applicable, to reflect the changes.
5. Changes have been made to more closely reflect the requirements of the Specification.
6. This Reviewer's Note has been deleted. This information is for the NRC reviewer to be keyed in to what is needed to meet this requirement. This is not meant to be retained in the final version of the plant specific submittal.
7. The brackets have been removed and the proper plant specific information/value has been provided.

All changes are [2] unless otherwise indicated

B 3.3 INSTRUMENTATION

B 3.3.5.2 Reactor Core Isolation Cooling (RCIC) System Instrumentation

BASES

insufficient or

BACKGROUND

RCIC System initiation occurs and maintains sufficient reactor water level such precluding

The purpose of the RCIC System instrumentation is to initiate actions to ensure adequate core cooling when the reactor vessel is isolated from its primary heat sink (the main condenser) and normal coolant makeup flow from the Reactor Feedwater System is unavailable, such that initiation of the low pressure Emergency Core Cooling Systems (ECCS) pumps does not occur. A more complete discussion of RCIC System operation is provided in the Bases of LCO 3.5.3, "RCIC System."

makeup water

Water Level -

level indicating switches

The logic can also be initiated by use of a manual initiation pushbutton

The RCIC System may be initiated by either automatic or manual means. Automatic initiation occurs for conditions of reactor vessel Low Low Water Level. The variable is monitored by four transmitters that are connected to four trip units. The outputs of the trip units are connected to relays whose contacts are arranged in a one-out-of-two taken twice logic arrangement. Once initiated, the RCIC logic seals in and can be reset by the operator only when the reactor vessel water level signals have cleared.

of the switches

The RCIC test line isolation valve to the reactor vessel (which is also a primary containment isolation valve) is closed on a RCIC initiation signal to allow full system flow and maintain primary containment isolated in the event RCIC is not operating.

The RCIC System also monitors the water levels in the contaminated condensate storage tank (CST) and the suppression pool since these are the two sources of water for RCIC operation.

both

are

Reactor grade water in the CST is the normal source. Upon receipt of a RCIC initiation signal, the CST suction valve is automatically signaled to open (it is normally in the open position) unless the pump suction from the suppression pool valves is open. If the water level in the CST falls below a preselected level, first the suppression pool suction valves automatically open, and then the CST suction valve automatically closes. Two level switches are used to detect low water level in the CST. either switch can cause the suppression pool suction valves to open and the CST suction valve to close. The suppression pool suction valves also automatically open and the CST suction valve closes if high water level is detected in the suppression pool

when these valves are fully open

any

any

The outputs for these switches are common between Units 1 and 2

(continued)

All changes are [2] unless otherwise indicated

BASES

BACKGROUND
(continued)

(one-out-of-two logic ~~similar to the CS water level logic~~). To prevent losing suction to the pump, the suction valves are interlocked so that one suction path must be open before the other automatically closes.

The RCIC System provides makeup water to the reactor until the reactor vessel water level reaches the high water level (Level B) trip (two-out-of-two logic), at which time the RCIC steam supply, ~~steam supply bypass, and cooling water supply valves close~~ (the injection valve also closes due to the closure of the steam supply valve). The RCIC System restarts if vessel level again drops to the low level initiation point (Level 2).

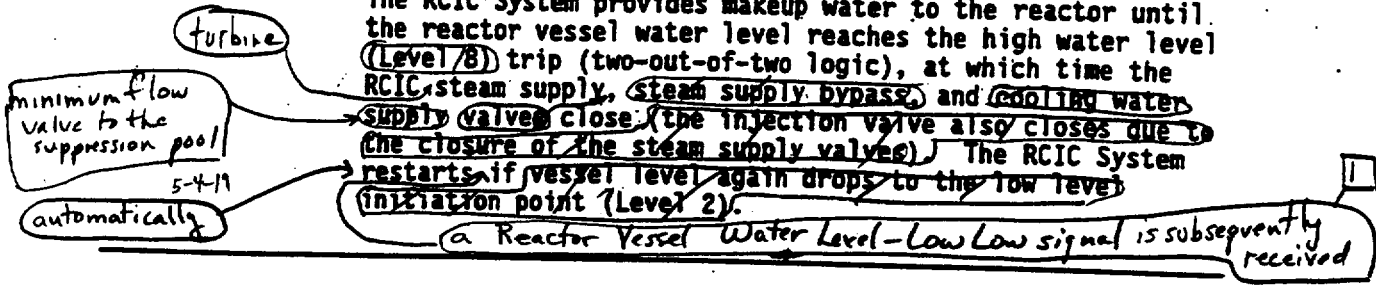

APPLICABLE SAFETY ANALYSES, LCO, and APPLICABILITY

The function of the RCIC System to provide makeup coolant to the reactor is used to respond to transient events. The RCIC System is not an Engineered Safety Feature System and no credit is taken in the safety analyses for RCIC System operation. Based on its contribution to the reduction of overall plant risk, however, the system, and therefore its instrumentation, are included in the technical specifications as required by the NRC Policy Statement. Certain instrumentation functions are retained for other reasons and are described below in the individual Functions discussion.

meets Criterion 4 of 10 CFR 50.36 (c)(2)(ii)

3

RCIC

The OPERABILITY of the RCIC System instrumentation is dependent upon the OPERABILITY of the individual instrumentation channel Functions specified in Table 3.3.5.2-1. Each Function must have a required number of OPERABLE channels with their setpoints within the specified Allowable Values, where appropriate. A channel is inoperable if its actual trip setpoint is not within its required Allowable Value. The actual setpoint is calibrated consistent with applicable setpoint methodology assumptions.

Allowable Values are specified for each RCIC System instrumentation Function specified in the Table. Nominal trip setpoints are specified in the setpoint calculations. The nominal setpoints are selected to ensure that the setpoints do not exceed the Allowable Value between CHANNEL

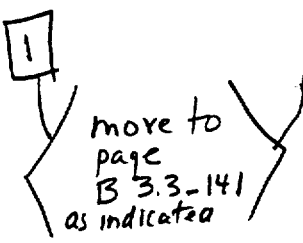

(continued)

Insert from page
B 3.3-140

BASES

APPLICABLE
SAFETY ANALYSES,
LCO, and
APPLICABILITY
(continued)

CALIBRATIONS. Operation with a trip setpoint less conservative than the nominal trip setpoint, but within its Allowable Value, is acceptable. Each Allowable Value specified accounts for instrument uncertainties appropriate to the function. These uncertainties are described in the setpoint methodology.

Insert ASA

2

The individual Functions are required to be OPERABLE in MODE 1, and in MODES 2 and 3 with reactor steam dome pressure > 150 psig since this is when RCIC is required to be OPERABLE. (Refer to LCO 3.5.3 for Applicability Bases for the RCIC System.)

The specific Applicable Safety Analyses, LCO, and Applicability discussions are listed below on a Function by-Function basis.

1. Reactor Vessel Water Level—Low Low Level 2

5

Reactor Vessel
Water Level—
Low Low

Low reactor pressure vessel (RPV) water level indicates that normal feedwater flow is insufficient to maintain reactor vessel water level and that the capability to cool the fuel may be threatened. Should RPV water level decrease too far, fuel damage could result. Therefore, the RCIC System is initiated at Level 2 to assist in maintaining water level above the top of the active fuel.

Indicating
switches

Reactor Vessel Water Level—Low Low Level 2 signals are initiated from four level transmitters that sense the difference between the pressure due to a constant column of water (reference leg) and the pressure due to the actual water level (variable leg) in the vessel.

Injection

The Reactor Vessel Water Level—Low Low Level 2 Allowable Value is set high enough such that for complete loss of feedwater flow, the RCIC System flow with high pressure coolant injection assumed to fail will be sufficient to avoid initiation of low pressure ECCS at Level 1.

Four channels of Reactor Vessel Water Level—Low Low Level 2 Function are available and are required to be OPERABLE when RCIC is required to be OPERABLE to ensure that no single instrument failure can preclude RCIC initiation. Refer to LCO 3.5.3 for RCIC Applicability Bases.

(continued)

2

Insert ASA

Trip setpoints are those predetermined values of output at which an action should take place. The setpoints are compared to the actual process parameter (e.g., reactor vessel water level), and when the measured output value of the process parameter exceeds the setpoint, the associated device (e.g., trip unit) changes state. The analytic limits (or design limits) are derived from the limiting values of the process parameters obtained from the safety analysis. The trip setpoints are determined from the analytic limits, corrected for defined process, calibration, and instrument errors. The Allowable Values are then determined, based on the trip setpoint values, by accounting for the calibration based errors. These calibration based errors are limited to reference accuracy, instrument drift, errors associated with measurement and test equipment, and calibration tolerance of loop components. The trip setpoints and Allowable Values determined in this manner provide adequate protection because instrument uncertainties, process effects, calibration tolerances, instrument drift, and severe environment errors (for channels that must function in harsh environments as defined by 10 CFR 50.49) are accounted for and appropriately applied for the instrumentation.

All changes are unless otherwise indicated

BASES

APPLICABLE SAFETY ANALYSES, LCO, and APPLICABILITY (continued)

2. Reactor Vessel Water Level—High Level B

Reactor Vessel Water Level—High

High RPV water level indicates that sufficient cooling water inventory exists in the reactor vessel such that there is no danger to the fuel. Therefore, the Level B signal is used to close the RCIC steam supply valve, steam supply bypass, and cooling water supply valves to prevent overflow into the main steam lines (MSLs). The injection valve also closes due to the closure of the steam supply valve.

turbine

indicating switches

The minimum flow valve to the suppression pool also closes

Reactor Vessel Water Level—High Level B signals for RCIC are initiated from two level transmitters from the narrow range water level measurement instrumentation, which sense the difference between the pressure due to a constant column of water (reference leg) and the pressure due to the actual water level (variable leg) in the vessel.

The Reactor Vessel Water Level—High Level B Allowable Value is high enough to preclude isolating the injection valve of the RCIC during normal operation, yet low enough to trip the RCIC System prior to water overflowing into the MSLs.

Two channels of Reactor Vessel Water Level—High Level B Function are available and are required to be OPERABLE when RCIC is required to be OPERABLE to ensure that no single instrument failure can preclude RCIC initiation. Refer to LCO 3.5.3 for RCIC Applicability Bases.

Contaminated

3. Condensate Storage Tank Level—Low

5
C
A
C

Low level in the CST indicates the unavailability of an adequate supply of makeup water from this normal source. Normally, the suction valve between the RCIC pump and the CST is open and, upon receiving a RCIC initiation signal, water for RCIC injection would be taken from the CST. However, if the water level in the CST falls below a preselected level, first the suppression pool suction valves automatically open, and then the CST suction valve (consistency) automatically closes. This ensures that an adequate supply of makeup water is available to the RCIC pump. To prevent losing suction to the pump, the suction valves are interlocked so that the suppression pool suction valves must be open before the CST suction valve automatically closes.

(continued)

2

These requirements will

BASES

Contaminated 5

APPLICABLE SAFETY ANALYSES, LCO, and APPLICABILITY

3. Condensate Storage Tank Level—Low (continued)

Two level switches are used to detect low water level in the CST. The Condensate Storage Tank Level—Low Function Allowable Value is set high enough to ensure adequate pump suction head while water is being taken from the CST.

each 5

and when both CCSTs are aligned to the RCIC System or two channels associated with the CCST aligned to RCIC when one CCST is isolated from the unit RCIC System.

Any 2 Contaminated 5
Two channels of Condensate Storage Tank Level—Low Function are available and are required to be OPERABLE when RCIC is required to be OPERABLE to ensure that no single instrument failure can preclude RCIC swap to suppression pool source. Refer to LCO 3.5.3 for RCIC Applicability Bases.

4. Suppression Pool Water Level—High

Excessively high suppression pool water level could result in the loads on the suppression pool exceeding design values should there be a blowdown of the reactor vessel pressure through the safety relief valves. Therefore, signals indicating high suppression pool water level are used to transfer the suction source of RCIC from the CST to the suppression pool to eliminate the possibility of RCIC continuing to provide additional water from a source outside primary containment. This Function satisfies Criterion 3 of the NRC Policy Statement. To prevent losing suction to the pump, the suction valves are interlocked so that the suppression pool suction valves must be open before the CST suction valve automatically closes.

10 CFR 50.36 (C)(2)(ii)

3

Suppression pool water level signals are initiated from two level switches. The Allowable Value for the Suppression Pool Water Level—High Function is set low enough to ensure that RCIC will be aligned to take suction from the suppression pool before the water level reaches the point at which suppression design loads would be exceeded.

Two channels of Suppression Pool Water Level—High Function are available and are required to be OPERABLE when RCIC is required to be OPERABLE to ensure that no single instrument failure can preclude RCIC swap to suppression pool source. Refer to LCO 3.5.3 for RCIC Applicability Bases.

2

The Allowable Value is confirmed by performance of a CHANNEL FUNCTIONAL TEST. This is acceptable since the design layout of the installation ensures the switches will trip at a level lower than the Allowable Value.

(continued)

BASES

**APPLICABLE
SAFETY ANALYSES,
LCO, and
APPLICABILITY
(continued)**

5. Manual Initiation

The Manual Initiation push button switch introduces a signal into the RCIC System initiation logic that is redundant to the automatic protective instrumentation and provides manual initiation capability. There is one push button for the RCIC System.

The Manual Initiation Function is not assumed in any accident or transient analyses in the FSAR. However, the Function is retained for overall redundancy and diversity of the RCIC function as required by the NRC in the plant licensing basis.

There is no Allowable Value for this Function since the channel is mechanically actuated based solely on the position of the push button. One channel of Manual Initiation is required to be OPERABLE when RCIC is required to be OPERABLE.

ACTIONS

Reviewer's Note: Certain LCO Completion Times are based on approved topical reports. In order for a licensee to use the times, the licensee must justify the Completion Times as required by the staff Safety Evaluation Report (SER) for the topical report.

A Note has been provided to modify the ACTIONS related to RCIC System instrumentation channels. Section 1.3, Completion Times, specifies that once a Condition has been entered, subsequent divisions, subsystems, components, or variables expressed in the Condition discovered to be inoperable or not within limits will not result in separate entry into the Condition. Section 1.3 also specifies that Required Actions of the Condition continue to apply for each additional failure, with Completion Times based on initial entry into the Condition. However, the Required Actions for inoperable RCIC System instrumentation channels provide appropriate compensatory measures for separate inoperable channels. As such, a Note has been provided that allows separate Condition entry for each inoperable RCIC System instrumentation channel.

(continued)

BASES

ACTIONS
(continued)

A.1

5
required

Required Action A.1 directs entry into the appropriate Condition referenced in Table 3.3.5.2-1. The applicable Condition referenced in the Table is Function dependent. Each time a channel is discovered to be inoperable, Condition A is entered for that channel and provides for transfer to the appropriate subsequent Condition.

B.1 and B.2

Required Action B.1 is intended to ensure that appropriate actions are taken if multiple, inoperable, untripped channels within the same Function result in a complete loss of automatic initiation capability for the RCIC System. In this case, automatic initiation capability is lost if two Function 1 channels in the same trip system are inoperable and untripped. In this situation (loss of automatic initiation capability), the 24 hour allowance of Required Action B.2 is not appropriate, and the RCIC System must be declared inoperable within 1 hour after discovery of loss of RCIC initiation capability.

The Completion Time is intended to allow the operator time to evaluate and repair any discovered inoperabilities. This Completion Time also allows for an exception to the normal "time zero" for beginning the allowed outage time "clock." For Required Action B.1, the Completion Time only begins upon discovery that the RCIC System cannot be automatically initiated due to two inoperable, untripped Reactor Vessel Water Level—Low Low, Level 2 channels in the same trip system. The 1 hour Completion Time from discovery of loss of initiation capability is acceptable because it minimizes risk while allowing time for restoration or tripping of channels.

2

1
credited

Because of the redundancy of sensors available to provide initiation signals and the fact that the RCIC System is not ~~assumed~~ in any accident or transient analysis, an allowable out of service time of 24 hours has been shown to be acceptable (Ref. 1) to permit restoration of any inoperable channel to OPERABLE status. If the inoperable channel cannot be restored to OPERABLE status within the allowable out of service time, the channel must be placed in the tripped condition per Required Action B.2. Placing the

(continued)

BASES

ACTIONS

B.1 and B.2 (continued)

inoperable channel in trip would conservatively compensate for the inoperability, restore capability to accommodate a single failure, and allow operation to continue. Alternately, if it is not desired to place the channel in trip (e.g., as in the case where placing the inoperable channel in trip would result in an initiation), Condition E must be entered and its Required Action taken.

C.1

A risk based analysis was performed and determined that an allowable out of service time of 24 hours (Ref. 1) is acceptable to permit restoration of any inoperable channel to OPERABLE status (Required Action C.1). A Required Action (similar to Required Action B.1) limiting the allowable out of service time, if a loss of automatic RCIC initiation capability exists, is not required. This Condition applies to the Reactor Vessel Water Level—High, Level B Function whose logic is arranged such that any inoperable channel will result in a loss of automatic RCIC initiation capability. As stated above, this loss of automatic RCIC initiation capability was analyzed and determined to be acceptable. This Condition also applies to the Manual Initiation Function. Since this Function is not assumed in any accident or transient analysis, a total loss of manual initiation capability (Required Action C.1) for 24 hours is allowed. The Required Action does not allow placing a channel in trip since this action would not necessarily result in a safe state for the channel in all events.

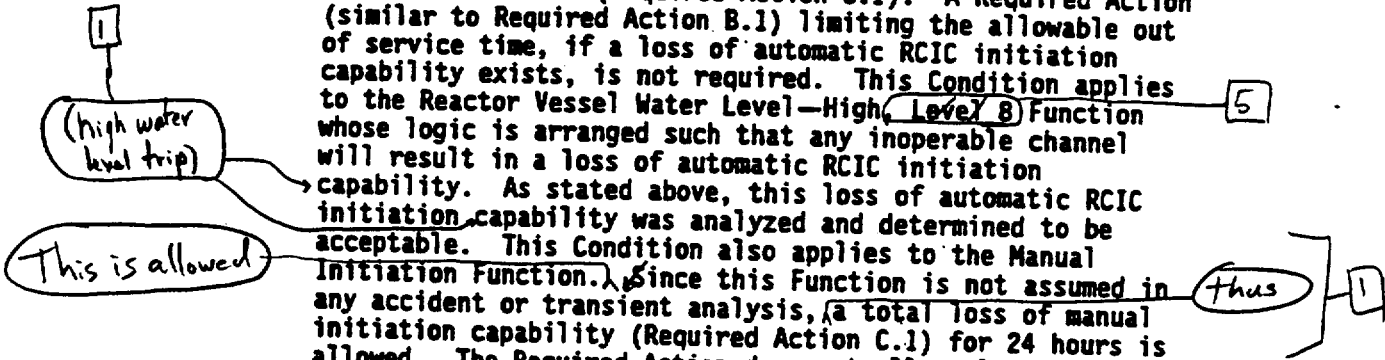

D.1, D.2.1, and D.2.2

Required Action D.1 is intended to ensure that appropriate actions are taken if multiple, inoperable, untripped channels within the same Function result in automatic component initiation capability being lost for the feature(s). For Required Action D.1, the RCIC System is the only associated feature. In this case, automatic initiation capability is lost if two Function 3 channels or two Function 4 channels are inoperable and untripped. In this situation (loss of automatic suction swap), the 24 hour allowance of Required Actions D.2.1 and D.2.2 is not

In this case if both CESTs are available RCIC automatic initiation (RCIC source swapper) capability is lost if four Function 3 channels (2 of the required channels) are inoperable and untripped. If one CEST is not available, automatic initiation capability is lost if two channels associated with the aligned CEST are inoperable and untripped.

(RCIC source swapper)

(continued)

BASES

ACTIONS

D.1, D.2.1, and D.2.2 (continued)

appropriate, and the RCIC System must be declared inoperable within 1 hour from discovery of loss of RCIC initiation capability. As noted, Required Action D.1 is only applicable if the RCIC pump suction is not aligned to the suppression pool since, if aligned, the Function is already performed.

The Completion Time is intended to allow the operator time to evaluate and repair any discovered inoperabilities. This Completion Time also allows for an exception to the normal "time zero" for beginning the allowed outage time "clock." For Required Action D.1, the Completion Time only begins upon discovery that the RCIC System cannot be automatically aligned to the suppression pool due to two inoperable, untripped channels in the same Function. The 1 hour Completion Time from discovery of loss of initiation capability is acceptable because it minimizes risk while allowing time for restoration or tripping of channels.

Because of the redundancy of sensors available to provide initiation signals and the fact that the RCIC System is not assumed in any accident or transient analysis, an allowable out of service time of 24 hours has been shown to be acceptable (Ref. 1) to permit restoration of any inoperable channel to OPERABLE status. If the inoperable channel cannot be restored to OPERABLE status within the allowable out of service time, the channel must be placed in the tripped condition per Required Action D.2.1, which performs the intended function of the channel (shifting the suction source to the suppression pool). Alternatively, Required Action D.2.2 allows the manual alignment of the RCIC suction to the suppression pool, which also performs the intended function. If Required Action D.2.1 or D.2.2 is performed, measures should be taken to ensure that the RCIC System piping remains filled with water. If it is not desired to perform Required Actions D.2.1 and D.2.2 (e.g., as in the case where shifting the suction source could drain down the RCIC suction piping), Condition E must be entered and its Required Action taken.

(continued)

BASES

ACTIONS
(continued)

E.1

With any Required Action and associated Completion Time not met, the RCIC System may be incapable of performing the intended function, and the RCIC System must be declared inoperable immediately.

SURVEILLANCE
REQUIREMENTS

Reviewer's Note: Certain Frequencies are based on approved topical reports. In order for a licensee to use these Frequencies, the licensee must justify the Frequencies as required by the staff SER for the topical report.

4

As noted in the beginning of the SRs, the SRs for each RCIC System instrumentation Function are found in the SRs column of Table 3.3.5.2-1.

The Surveillances are modified by a Note to indicate that when a channel is placed in an inoperable status solely for performance of required Surveillances, entry into associated Conditions and Required Actions may be delayed as follows: (a) for up to 6 hours for Functions 2 and 5; and (b) for up to 6 hours for Functions 1, 3, and 4, provided the associated Function maintains ~~CPD~~ capability. Upon completion of the Surveillance, or expiration of the 6 hour allowance, the channel must be returned to OPERABLE status or the applicable Condition entered and Required Actions taken. This Note is based on the reliability analysis (Ref. 1) assumption of the average time required to perform channel surveillance. That analysis demonstrated that the 6 hour testing allowance does not significantly reduce the probability that the RCIC will initiate when necessary.

RCIC
initiation
1

SR 3.3.5.2.1

Performance of the CHANNEL CHECK once every 12 hours ensures that a gross failure of instrumentation has not occurred. A CHANNEL CHECK is normally a comparison of the parameter indicated on one channel to a parameter on other similar channels. It is based on the assumption that instrument channels monitoring the same parameter should read approximately the same value. Significant deviations between the instrument channels could be an indication of excessive instrument drift in one of the channels or

(continued)

BASES

SURVEILLANCE
REQUIREMENTS

SR 3.3.5.2.1 (continued)

something even more serious. A CHANNEL CHECK will detect gross channel failure; thus, it is key to verifying the instrumentation continues to operate properly between each CHANNEL CALIBRATION.

Agreement criteria are determined by the plant staff based on a combination of the channel instrument uncertainties, including indication and readability. If a channel is outside the criteria, it may be an indication that the instrument has drifted outside its limit.

The Frequency is based upon operating experience that demonstrates channel failure is rare. The CHANNEL CHECK supplements less formal, but more frequent, checks of channels during normal operational use of the displays associated with the channels required by the LCO.

and SR 3.3.5.2.4

5

SR 3.3.5.2.2

A CHANNEL FUNCTIONAL TEST is performed on each required channel to ensure that the entire channel will perform the intended function.

Any setpoint adjustment shall be consistent with the assumptions of the current plant specific setpoint methodology.

SR 3.3.5.2.4

The Frequency of 92 days is based on the reliability analysis of Reference 1.

5

5
The 31 day Frequency of SR 3.3.5.2.2 is based on the reliability of the components

92 day

SR 3.3.5.2.3

The calibration of trip units provides a check of the actual trip setpoints. The channel must be declared inoperable if the trip setting is discovered to be less conservative than the Allowable Value specified in Table 3.3.5.2-1. If the trip setting is discovered to be less conservative than the setting accounted for in the appropriate setpoint methodology, but is not beyond the Allowable Value, the channel performance is still within the requirements of the plant safety analysis. Under these conditions, the setpoint

5

(continued)

BASES

SURVEILLANCE
REQUIREMENTS

SR 3.3.5.2.3 (continued)

must be readjusted to be equal to or more conservative than accounted for in the appropriate setpoint methodology.

The Frequency of 92 days is based on the reliability analysis of Reference 1.

5

SR 3.3.5.2.4 and SR 3.3.5.2.5

A CHANNEL CALIBRATION is a complete check of the instrument loop and the sensor. This test verifies the channel responds to the measured parameter within the necessary range and accuracy. CHANNEL CALIBRATION leaves the channel adjusted to account for instrument drifts between successive calibrations consistent with the plant specific setpoint methodology.

5

60 The Frequency of SR 3.3.5.2.4 is based upon the assumption of a 92 day calibration interval in the determination of the magnitude of equipment drift in the setpoint analysis.

24 The Frequency of SR 3.3.5.2.5 is based upon the assumption of an 18 month calibration interval in the determination of the magnitude of equipment drift in the setpoint analysis.

SR 3.3.5.2.6

The LOGIC SYSTEM FUNCTIONAL TEST demonstrates the OPERABILITY of the required initiation logic for a specific channel. The system functional testing performed in LCO 3.5.3 overlaps this Surveillance to provide complete testing of the safety function.

5

24

The 18 month Frequency is based on the need to perform this Surveillance under the conditions that apply during a plant outage and the potential for an unplanned transient if the Surveillance were performed with the reactor at power. Operating experience has shown that these components usually pass the Surveillance when performed at the 18 month Frequency.

24 5

(continued)

BASES (continued)

GENE

2

A

REFERENCES

1. ~~NEP~~-770-06-2, "Addendum to Bases for Changes to Surveillance Test Intervals and Allowed Out-of-Service Times for Selected Instrumentation Technical Specifications," February 1991.

December 1992

2

JUSTIFICATION FOR DEVIATIONS FROM NUREG-1433, REVISION 1
ITS BASES: 3.3.5.2 - RCIC SYSTEM INSTRUMENTATION

1. Editorial change made for enhanced clarity or to be consistent with similar statements in other places in the Bases.
2. Changes have been made (additions, deletions, and/or changes to the NUREG) to reflect the plant specific methodology, nomenclature, number, reference, system description, analysis description, or licensing basis description.
3. The proper 10 CFR 50.36(c)(2)(ii) criterion has been used. The current wording was developed prior to the issuance of the change to 10 CFR 50.36, which uses criterion 4 for the current words in the NUREG.
4. This Reviewer's Note has been deleted. This information is for the NRC reviewer to be keyed in to what is needed to meet this requirement. This is not meant to be retained in the final version of the plant specific submittal.
5. Changes have been made to reflect those changes made to the Specification. The following requirements have been renumbered, where applicable, to reflect the changes.

B 3.3 INSTRUMENTATION

B 3.3.6.1 Primary Containment Isolation Instrumentation

BASES

BACKGROUND

The primary containment isolation instrumentation automatically initiates closure of appropriate primary containment isolation valves (PCIVs). The function of the PCIVs, in combination with other accident mitigation systems, is to limit fission product release during and following postulated Design Basis Accidents (DBAs). Primary containment isolation within the time limits specified for those isolation valves designed to close automatically ensures that the release of radioactive material to the environment will be consistent with the assumptions used in the analyses for a DBA.

The isolation instrumentation includes the sensors, relays, and switches that are necessary to cause initiation of primary containment and reactor coolant pressure boundary (RCPB) isolation. Most channels include electronic equipment (e.g., trip units) that compares measured input signals with pre-established setpoints. When the setpoint is exceeded, the channel output relay actuates, which then outputs a primary containment isolation signal to the isolation logic. Functional diversity is provided by monitoring a wide range of independent parameters. The input parameters to the isolation logics are (a) reactor vessel water level, (b) area ambient ~~and differential~~ temperatures, (c) main steam line (MSL) flow measurement, (d) Standby Liquid Control (SLC) System initiation, (e) ~~condenser/vacuum~~, (f) main steam line pressure, (g) high pressure coolant injection (HPCI) and reactor core isolation cooling (RCIC) steam line flow, (h) drywell radiation and pressure, (i) HPCI and RCIC steam line pressure, (j) ~~HPCI and RCIC turbine exhaust diaphragm pressure~~, (k) ~~reactor water cleanup (RWCU) differential flow~~, and (l) reactor ~~steam dome~~ pressure. Redundant sensor input signals from each parameter are provided for initiation of isolation. The only exception is SLC System initiation. ~~In addition, manual isolation of the logics is provided.~~

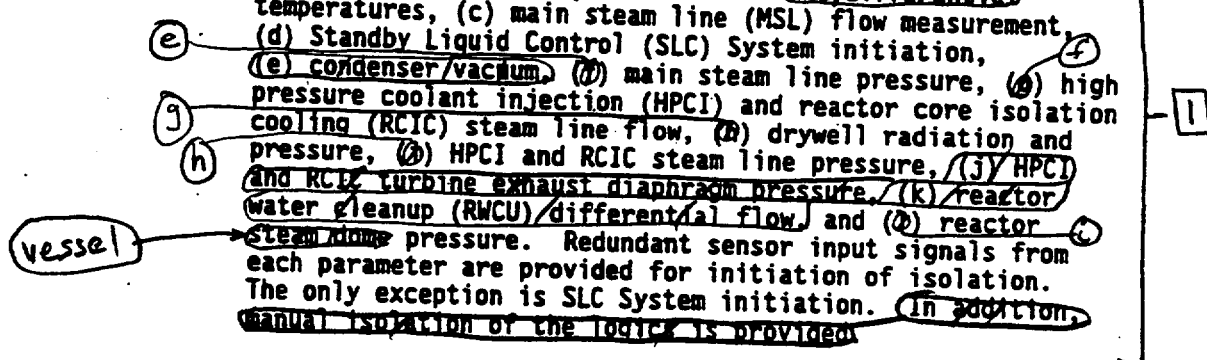

Primary containment isolation instrumentation has inputs to the trip logic of the isolation functions listed below.

(continued)

All changes are II unless otherwise identified

Primary Containment Isolation Instrumentation
B 3.3.6.1

BASES The Reactor Vessel Water Level - Low, the Main Steam Line Pressure - Low, and the Main Steam Line Pressure - Timer

BACKGROUND
(continued)

1. Main Steam Line Isolation

Insert BK6D-1

Most/MSD Isolation Functions receive inputs from four channels. The outputs from these channels are combined in a one-out-of-two taken twice logic to initiate isolation of all main steam isolation valves (MSIVs). The outputs from the same channels are arranged into two two-out-of-two logic trip systems to isolate all MSL drain valves. Each MSL drain line has two isolation valves with one two-out-of-two logic system associated with each valve.

of all MSIVs, MSL drain valves, and recirculation sample isolation valves

The exceptions to this arrangement are the Main Steam Line Flow-High Function and Area and Differential Temperature Functions. The Main Steam Line Flow-High Function uses 16 flow channels, four for each steam line. One channel from each steam line inputs to one of the four trip strings. Two trip strings make up each trip system and both trip systems must trip to cause an MSD isolation. Each trip string has four inputs (one per MSL), any one of which will trip the trip string. The trip strings are arranged in a one-out-of-two taken twice logic. This is effectively a one-out-of-eight taken twice logic arrangement to initiate isolation of the MSIVs. Similarly, the 16 flow channels are connected into two two-out-of-two logic trip systems (effectively, two one-out-of-four twice logic), with each trip system isolating one of the two MSL drain valves on the associated steam line.

four for each of the four tunnel areas

The Main Steam Tunnel Temperature-High Function receives input from 16 channels. The logic is arranged similar to the Main Steam Line Flow-High Function. The Turbine Building Area Temperature-High Function receives input from 64 channels. The inputs are arranged in a one-out-of-thirty-two taken twice logic trip system to isolate all MSIVs. Similarly, the inputs are arranged in two one-out-of-sixteen twice logic trip systems, with each trip system isolating one of the two MSL drain valves per drain line.

MSL Isolation Functions isolate the Group 1 valves.

2. Primary Containment Isolation

Most Primary Containment Isolation Functions receive inputs from four channels. The outputs from these channels are

Insert BK6D-2

(continued)

The Reactor Vessel Water Level - Low and Drywell Pressure - High

One channel from each steam tunnel area inputs to one of four trip strings. Two trip strings make up a trip system and both trip systems must trip to cause isolation.

□

INSERT BKGD-1

One channel associated with each Function inputs to one of four trip strings. Two trip strings make up a trip system and both trip systems must trip to cause an isolation of all main steam isolation valves (MSIVs), MSL drain valves, and recirculation loop sample isolation valves. Any channel will trip the associated trip string. Only one trip string must trip to trip the associated trip system. The trip strings are arranged

□

INSERT BKDG-2

One channel associated with each Function inputs to one of four trip strings. Two trip strings make up a trip system and both trip systems must trip to cause an isolation of the PCIVs identified in Reference 1. Any channel will trip the associated trip string. Only one trip string must trip to trip the associated trip system. The trip strings are arranged in a one-out-of-two taken twice logic to initiate isolation.

All changes are [] unless otherwise identified

BASES

BACKGROUND

2. Primary Containment Isolation (continued)

arranged into two two-out-of-two logic trip systems. One trip system initiates isolation of all inboard primary containment isolation valves, while the other trip system initiates isolation of all outboard primary containment isolation valves. Each logic closes one of the two valves on each penetration, so that operation of either logic isolates the penetration.

Insert BK6D-3

The exception to this arrangement is the Drywell Radiation-High Function. This Function has two channels, whose outputs are arranged in two one-out-of-one logic trip systems. Each trip system isolates one valve per associated penetration, similar to the two-out-of-two logic described above.

Primary Containment Isolation Drywell Pressure-High and Reactor Vessel Water Level-Low, Level 3 Functions isolate the Group 2, 6, 7, 10, and 12 valves. Reactor Building and Refueling Floor Exhaust Radiation-High Functions isolate the Group 6, 10, and 12 valves. Primary Containment Isolation Drywell Radiation-High Function isolates the containment/purge and vent valves.

The HPCI steam flow -High and HPCI Steam Flow Timer Functions each

3. 4. High Pressure Coolant Injection System Isolation and Reactor Core Isolation Cooling System Isolation

Most functions that isolate HPCI and RCIC receive input from two channels, with each channel in one trip system using a one-out-of-one logic. Each of the two trip systems in each isolation group is connected to one of the two valves on each associated penetration.

the HPCI Steam supply

Insert BK6D-4

The exceptions are the HPCI and RCIC Turbine Exhaust Diaphragm Pressure-High and Steam Supply Line Pressure-Low Functions. These functions receive inputs from four turbine exhaust diaphragm pressure and four steam supply pressure channels for each system. The outputs from the turbine exhaust diaphragm pressure and steam supply pressure channels are each connected to two two-out-of-two trip systems. Each trip system isolates one valve per associated penetration.

HPCI

on the HPCI steam supply

The RCIC Steam Supply Line Pressure-Low channels are arranged in a one one-out-of-two twice trip system. The trip system is connected to both RCIC steam supply isolation valves

(continued)

Insert BK6D-5

□ INSERT BKGD-3

The Drywell Radiation-High Function receives input from two radiation detector assemblies each connected to a switch. Each switch actuates two contacts. Each contact inputs to one of four trip strings. Two trip strings make up a trip system and both trip systems must trip to cause an isolation of the PCIVs identified in Reference 1. The contacts associated with the same switch provide input to both trip strings in the same trip system. Any contact will trip the associated trip string. The trip strings are arranged in a one-out-of-two taken twice logic. For the purpose of this Specification, a channel is considered to include a radiation detector assembly, a switch, and one of two contacts.

□ INSERT BKGD-4

The RCIC Steam Flow-High and RCIC Steam Flow-Timer Functions each receive input from two channels. Each channel is connected to two trip systems, each using a one-out-of-two logic. Each of the two trip systems is connected to both RCIC steam supply isolation valves, such that any trip system will isolate both valves. For the purpose of this Specification, two RCIC Steam Flow-High Function channels and the associated RCIC Steam Flow-Timers must be OPERABLE (one separate channel for each trip system).

□ INSERT BKGD-5

The HPCI Drywell Pressure-High Function receives input from four channels. Two channels provide input to one trip system and the other two channels provide input to a second trip system. In addition, four HPCI Steam Supply Line Pressure-Low Function channels are also connected to these trip systems. Each of the two trip systems receives input from two additional HPCI Steam Supply Line Pressure-Low Function channels. Each trip system is arranged such that one channel associated with each Function must trip in order to initiate isolation of one HPCI vacuum breaker isolation valve. The logic in each trip system is one-out-of-two for each Function.

The HPCI Turbine Area Temperature-High Function receives input from four channels. Two channels monitor the area near the steam supply line while the other two channels monitor the temperature near the turbine exhaust rupture disc. Each of the two trip systems receives input from one channel in each of the two areas. Each trip system is arranged such that both channels must trip in order to initiate isolation. This is effectively a two-out-of-two logic arrangement. Each of the two trip systems is connected to one of the two valves on the HPCI steam supply penetration. The RCIC Turbine Area Temperature-High Function receives input from four channels. The four channels monitor the area near the RCIC turbine. Each of the two trip systems receives input from the four channels. Each trip system is arranged in a one-out-of-two taken twice logic to initiate isolation. Each of the two trip systems is connected to both RCIC steam supply isolation valves, such that any trip system will isolate both valves. For the purpose of this Specification, two unique RCIC Turbine Area Temperature-High Function channels must be OPERABLE to support each trip system such that with both channels tripped in a trip system an isolation signal will occur.

All changes are □ unless otherwise indicated

Primary Containment Isolation Instrumentation
B 3.3.6.1

BASES

BACKGROUND

3. 4. High Pressure Coolant Injection System Isolation and Reactor Core Isolation Cooling System Isolation (continued)

HPCI and RCIC Functions isolate the Group 3, 4, 5 and 6 valves.

2 as appropriate

5. Reactor Water Cleanup System Isolation

The Reactor Vessel Water Level—Low Low Level Isolation Function receives input from four reactor vessel water level channels. The outputs from the reactor vessel water level channels are connected into two two-out-of-two trip systems. The Differential Flow—High and SLC System Initiation Function receives input from two channels, with each channel

Insert BKGD-6

Insert BKGD-7

in one trip system using a one-out-of-one logic. The Area Temperature—High function receives input from six temperature monitors, three to each trip system. The Area Ventilation Differential Temperature—High Function receives input from six differential temperature monitors, three in each trip system. These are configured so that any one input will trip the associated trip system. Each of the two trip systems is connected to one of the two valves on each RWCU penetration.

Residual Heat Removal (RHR)

RWCU Functions isolate the Group 3 valves.

6. Shutdown Cooling System Isolation

The Reactor Vessel Water Level—Low Level 3 Function receives input from four reactor vessel water level channels. The outputs from the reactor vessel water level channels are connected to two two-out-of-two trip systems. The Reactor Vessel Pressure—High function receives input from two channels, with each channel in one trip system using a one-out-of-one logic. Each of the two trip systems is connected to one of the two valves on each shutdown cooling penetration.

Insert BKGD-8

both of which provide input to both trip systems. Any channel will trip both trip systems. This is

for each trip system

Shutdown Cooling System Isolation Functions isolate RHR Some Group 1 valves.

2 (RHR SDC suction isolation valves)

RHR SDC suction

□

Insert BKGD-6

One channel associated with each Function inputs to one of four trip stings. Two trip strings make up a trip system and both trip systems must trip to cause an isolation of the reactor water cleanup (RWCU) valves. Any channel will trip the associated trip string. Only one trip string must trip to trip the associated trip system. The trip strings are arranged in a one-out-of-two taken twice logic to initiate isolation.

□

Insert BKGD-7

the SLC initiation switch. The switch provides trip signal inputs to both trip systems in any position other than "OFF". The other switch positions are SYS 1, SYS 2, SYS 1+2 and SYS 2+1. For the purpose of this Specification, the SLC initiation switch is considered to provide 1 channel input into each trip system.

□

Insert BKGD-8

One channel associated with each Function inputs to one of four trip stings. Two trip strings make up a trip system and both trip systems must trip to cause an isolation of the RHR SDC suction isolation valves. Any channel will trip the associated trip string. Only one trip string must trip to trip the associated trip system. The trip strings are arranged in a one-out-of-two taken twice logic to initiate isolation.

Primary Containment Isolation Instrumentation
B 3.3.6.1

BASES (continued)

APPLICABLE
SAFETY ANALYSES,
LCO, and
APPLICABILITY

The isolation signals generated by the primary containment instrumentation are implicitly assumed in the safety analyses of References ③ and ④ to initiate closure of valves to limit offsite doses. Refer to LCO 3.6.1.3, "Primary Containment Isolation Valves (PCIVs)," Applicable Safety Analyses Bases for more detail of the safety analyses.] 1

10 CFR 50.36(c)(2)(ii)

Primary containment isolation instrumentation satisfies Criterion 3 of the NRC Policy Statement. Certain instrumentation Functions are retained for other reasons and are described below in the individual Functions discussion.] 1

The OPERABILITY of the primary containment instrumentation is dependent on the OPERABILITY of the individual instrumentation channel Functions specified in Table 3.3.6.1-1. Each Function must have a required number of OPERABLE channels, with their setpoints within the specified Allowable Values, where appropriate. A channel is inoperable if its actual trip setpoint is not within its required Allowable Value. The actual setpoint is calibrated consistent with applicable setpoint methodology assumptions. Each channel must also respond within its assumed response time, where appropriate.] 2

Allowable Values are specified for each Primary Containment Isolation Function specified in the Table. Nominal trip setpoints are specified in the setpoint calculations. The nominal setpoints are selected to ensure that the setpoints do not exceed the Allowable Value between CHANNEL CALIBRATIONS. Operation with a trip setpoint less conservative than the nominal trip setpoint, but within its Allowable Value, is acceptable. Trip setpoints are those predetermined values of output at which an action should take place. The setpoints are compared to the actual process parameter (e.g., reactor vessel water level), and when the measured output value of the process parameter exceeds the setpoint, the associated device (e.g., trip unit) changes state. The analytic limits are derived from the limiting values of the process parameters obtained from the safety analysis. The Allowable Values are derived from the analytic limits, corrected for calibration, process, and some of the instrument errors. The trip setpoints are then determined accounting for the remaining instrument errors (e.g., drift). The trip setpoints derived in this manner provide adequate protection because instrumentation] 1

Insert
ASA

(continued)

Insert ASA

The trip setpoints are determined from the analytic limits, corrected for defined process, calibration, and instrument errors. The Allowable Values are then determined, based on the trip setpoint values, by accounting for the calibration based errors. These calibration based errors are limited to reference accuracy, instrument drift, errors associated with measurement and test equipment, and calibration tolerance of loop components. The trip setpoints and Allowable Values determined in this manner provide adequate protection because instrument uncertainties, process effects, calibration tolerances, instrument drift, and severe environment errors (for channels that must function in harsh environments as defined by 10 CFR 50.49) are accounted for and appropriately applied for the instrumentation.

All changes are [] unless otherwise indicated

Primary Containment Isolation Instrumentation
B 3.3.6.1

BASES

APPLICABLE SAFETY ANALYSES, LCO, and APPLICABILITY (continued)

uncertainties, process effects, calibration tolerances/instrument drift, and severe environment errors (for channels that must function in harsh environments as defined by 10/CFR 50.49) are accounted for.

RHR containment Spray Isolation Valves

Some

Certain Emergency Core Cooling Systems (ECCS) and RCIC valves (e.g., ~~minimum flow~~) also serve the dual function of automatic PCIVs. The signals that isolate these valves are also associated with the automatic initiation of the ECCS ~~and RCIC~~. The instrumentation requirements and ACTIONS associated with these signals are addressed in LCO 3.3.5.1, "Emergency Core Cooling Systems (ECCS) Instrumentation," and LCO 3.3.5.2, "~~Reactor Core Isolation Cooling (RCIC) System Instrumentation~~," and are not included in this LCO.

In general, the individual Functions are required to be OPERABLE in MODES 1, 2, and 3 consistent with the Applicability for LCO 3.6.1.1, "Primary Containment." Functions that have different Applicabilities are discussed below in the individual Functions discussion.

The specific Applicable Safety Analyses, LCO, and Applicability discussions are listed below on a Function by Function basis.

Main Steam Line Isolation

1.a. Reactor Vessel Water Level—Low Low ~~Low Level~~ 1 [4]

Low reactor pressure-vessel (RPV) water level indicates that the capability to cool the fuel may be threatened. Should RPV water level decrease too far, fuel damage could result. Therefore, isolation of the MSIVs and other interfaces with the reactor vessel occurs to prevent offsite dose limits from being exceeded. The Reactor Vessel Water Level—Low Low ~~Low Level~~ Function is one of the many Functions assumed to be OPERABLE and capable of providing isolation signals. The Reactor Vessel Water Level—Low Low ~~Low Level~~ Function associated with isolation is assumed in the analysis of the recirculation line break (Ref. 2). The isolation of the MSLs ~~on Level~~ supports actions to ensure that offsite dose limits are not exceeded for a DBA. [4]

Reactor vessel water level signals are initiated from four ~~(EVP)~~ transmitters that sense the difference between the differential pressure. [5]

(continued)

All changes are unless otherwise indicated

Primary Containment Isolation Instrumentation
B 3.3.6.1

BASES

APPLICABLE
SAFETY ANALYSES,
LCO, and
APPLICABILITY

1.a. Reactor Vessel Water Level—Low Low (Low/Level/1) 4
(continued)

pressure due to a constant column of water (reference leg) and the pressure due to the actual water level (variable leg) in the vessel. Four channels of Reactor Vessel Water Level—Low Low (Low/Level/1) Function are available and are required to be OPERABLE to ensure that no single instrument failure can preclude the isolation function. 4

The Reactor Vessel Water Level—Low Low (Low/Level/1) Allowable Value is chosen to be the same as the ECCS (Level/1) Allowable Value (LCO 3.3.5.1) to ensure that the MSIs isolate on a potential loss of coolant accident (LOCA) to prevent offsite doses from exceeding 10 CFR 100 limits. 4

Reactor Vessel Water Level—Low Low

This Function isolates the Group 1 valves.

1.b. Main Steam Line Pressure—Low

Low MSL pressure indicates that there may be a problem with the turbine pressure regulation, which could result in a low reactor vessel water level condition and the RPV cooling down more than 100°F/hr if the pressure loss is allowed to continue. The Main Steam Line Pressure—Low Function is directly assumed in the analysis of the pressure regulator failure (Ref. 2). For this event, the closure of the MSIVs ensures that the RPV temperature change limit (100°F/hr) is not reached. In addition, this Function supports actions to ensure that Safety Limit 2.1.1.1 is not exceeded. (This Function closes the MSIVs prior to pressure decreasing below 785 psig, which results in a scram due to MSIV closure, thus reducing reactor power to < 25% RTP.)

1
6

Close to the turbine stop valves

The MSL low pressure signals are initiated from four transmitters that are connected to the MSL header. The transmitters are arranged such that, even though physically separated from each other, each transmitter is able to detect low MSL pressure. Four channels of Main Steam Line Pressure—Low Function are available and are required to be OPERABLE to ensure that no single instrument failure can preclude the isolation function. pressure

switches

switch

The Allowable Value was selected to be high enough to prevent excessive RPV depressurization.

(continued)

BASES

APPLICABLE
SAFETY ANALYSES,
LCO, and
APPLICABILITY

4
Insert
Function I.C

1.b. Main Steam Line Pressure—Low (continued)

The Main Steam Line Pressure—Low Function is only required to be OPERABLE in MODE 1 since this is when the assumed transient can occur (Ref. ②). ⑥

This Function isolates the Group 1 valves. ①

1.c. Main Steam Line Flow—High ④

Main Steam Line Flow—High is provided to detect a break of the MSL and to initiate closure of the MSIVs. If the steam were allowed to continue flowing out of the break, the reactor would depressurize and the core could uncover. If the RPV water level decreases too far, fuel damage could occur. Therefore, the isolation is initiated on high flow to prevent or minimize core damage. The Main Steam Line Flow—High Function is directly assumed in the analysis of the main steam line break (MSLB) (Ref. ②). The isolation action, along with the scram function of the Reactor Protection System (RPS), ensures that the fuel peak cladding temperature remains below the limits of 10 CFR 50.46 and offsite doses do not exceed the 10 CFR 100 limits. ⑦ ①

the differential pressure switches sense differential pressure across a flow restrictor ①

The MSL flow signals are initiated from 16 ~~transmitters~~ that are connected to the four MSLs. The ~~transmitters~~ are arranged such that, even though physically separated from each other, all four connected to one MSL would be able to detect the high flow. Four channels of Main Steam Line Flow—High Function for each ~~unisolated~~ MSL (two channels per trip system) are available and are required to be OPERABLE so that no single instrument failure will preclude detecting a break in any individual MSL. differential pressure switches ③

The Allowable Value is chosen to ensure that offsite dose limits are not exceeded due to the break.

This Function isolates the Group 1 valves. ④ ①

1.d. Condenser Vacuum—Low

The Condenser Vacuum—Low Function is provided to prevent overpressurization of the main condenser in the event of a loss of the main condenser vacuum. Since the integrity of the condenser is an assumption in offsite dose calculations, the Condenser Vacuum—Low Function is assumed to be OPERABLE

(continued)

1.c Main Steam Line Pressure-Timer

The Main Steam Line Pressure-Timer is provided to prevent false isolations on low MSL pressure as a result of pressure transients, however, the timer must function in a limited time period to support the OPERABILITY of the Main Steam Line Pressure-Low Function by enabling the associated channels after a certain time delay. The Main Steam Line Pressure-Timer is directly assumed in the analysis of the pressure regulator failure (Ref. 6). For this event, the closure of the MSIVs ensures that the RPV temperature limit (100°F/hr) is not reached. In addition, this Function supports actions to ensure that Safety Limit 2.1.1.1 is not exceeded.

The MSL low pressure timer signals are initiated when the associated MSL low pressure switch actuates. Four channels of Main Steam Line Pressure-Timer Function are available and are required to be OPERABLE to ensure that no single instrument failure can preclude the isolation function.

The Allowable Value is chosen to be long enough to prevent false isolations due to pressure transients but short enough as to prevent excessive RPV depressurization.

This Function isolates the Group 1 valves.

All changes are unless otherwise identified

Primary Containment Isolation Instrumentation
B 3.3.6.1

BASES

APPLICABLE
SAFETY ANALYSES,
LCO, and
APPLICABILITY

1.d. Condenser Vacuum—Low (continued)

and capable of initiating closure of the MSIVs. The closure of the MSIVs is initiated to prevent the addition of steam that would lead to additional condenser pressurization and possible rupture of the diaphragm installed to protect the turbine exhaust hood, thereby preventing a potential radiation leakage path following an accident.

Condenser vacuum pressure signals are derived from four pressure transmitters that sense the pressure in the condenser. Four channels of Condenser Vacuum—Low Function are available and are required to be OPERABLE to ensure that no single instrument failure can preclude the isolation function.

The Allowable Value is chosen to prevent damage to the condenser due to pressurization, thereby ensuring its integrity for offsite dose analysis. As noted (footnote (a) to Table 3.3.6.1-1), the channels are not required to be OPERABLE in MODES 2 and 3 when all turbine stop valves (TSVs) are closed, since the potential for condenser overpressurization is minimized. Switches are provided to manually bypass the channels when all TSVs are closed.

This Function isolates the Group 1 valves.

4
Main Steam Line
Tunnel

1.e. 1.f./1.g. (Area and Differential) Temperature—High

4
Main steam line
Tunnel

Area and differential temperature is provided to detect a leak in the RCPB and provides diversity to the high flow instrumentation. (The isolation occurs when a very small leak has occurred. If the small leak is allowed to continue without isolation, offsite dose limits may be reached. However, credit for these instruments is not taken in any transient or accident analysis in the FSAR, since bounding analyses are performed for large breaks, such as MSLBs.)

in the steam
tunnel

in any one of the
four areas

Area temperature signals are initiated from thermocouples located in the area being monitored. Sixteen channels of Main Steam Tunnel Temperature—High Function and 64 channels of Turbine Building Area Temperature—High Function are available and are required to be OPERABLE to ensure that no single instrument failure can preclude the isolation function. Each Function has one temperature element.

bimetallic
temperature
switches

Line
but only eight channels
(two channels in each of
the four tripstrings)

Even though physically separated from each other, any temperature switch in any of the four areas is able to detect a leak. (continued)

Temperature is sensed in four
different areas of the steam
tunnel above each main steam line

All changes are [1] unless otherwise identified

Primary Containment Isolation Instrumentation
B 3.3.6.1

BASES

Main Steam Line Tunnel [4]

APPLICABLE
SAFETY ANALYSES,
LCO, and
APPLICABILITY

l.e. V.f. A.g) (Area and Differential) Temperature—High
(continued)

Main Steam Line
Tunnel Temperature
—High

Eight thermocouples provide input to the Differential Temperature—High Function. The output of these thermocouples is used to determine the differential temperature. Each channel consists of a differential temperature instrument that receives inputs from thermocouples that are located in the inlet and outlet of the area cooling system for a total of four available channels.

The ambient and differential temperature monitoring Allowable Value is chosen to detect a leak equivalent to between 1% and 10% rated steam flow. [4]

These Functions isolate the Group 1 valves.

l.h. Manual Initiation [1] [4]

The Manual Initiation push button channels introduce signals into the MSL isolation logic that are redundant to the automatic protective instrumentation and provide manual isolation capability. There is no specific FSAR safety analysis that takes credit for this Function. It is retained for the overall redundancy and diversity of the isolation function as required by the NRC in the plant licensing basis.

There are two push buttons for the logic, one manual initiation push button per trip system. There is no Allowable Value for this Function since the channels are mechanically actuated based solely on the position of the push buttons.

Two channels of Manual Initiation Function are available and are required to be OPERABLE in MODES 1, 2, and 3, since these are the MODES in which the MSL isolation automatic Functions are required to be OPERABLE.

(continued)

All changes are unless otherwise indicated

Primary Containment Isolation Instrumentation
B 3.3.6.1

BASES

APPLICABLE
SAFETY ANALYSES,
LCO, and
APPLICABILITY
(continued)

Primary Containment Isolation

2.a. Reactor Vessel Water Level—Low Level 3 4

4
low RPV water level

Low RPV water level indicates that the capability to cool the fuel may be threatened. The valves whose penetrations communicate with the primary containment are isolated to limit the release of fission products. The isolation of the primary containment on Level 3 supports actions to ensure that offsite dose limits of 10 CFR 100 are not exceeded. The Reactor Vessel Water Level—Low Level 3 Function associated with isolation is implicitly assumed in the FSAR analysis as these leakage paths are assumed to be isolated post LOCA. u

differential pressure

Reactor Vessel Water Level—Low Level 3 signals are initiated from Level 3 transmitters that sense the difference between the pressure due to a constant column of water (reference leg) and the pressure due to the actual water level (variable leg) in the vessel. Four channels of Reactor Vessel Water Level—Low Level 3 Function are available and are required to be OPERABLE to ensure that no single instrument failure can preclude the isolation function. 4

The Reactor Vessel Water Level—Low Level 3 Allowable Value was chosen to be the same as the RPS Level 3 scram Allowable Value (LCO 3.3.1.1), since isolation of these valves is not critical to orderly plant shutdown. Reactor Vessel Water Level—Low 4

This Function isolates the Group 2 6, 10, and 12 valves.

2.b. Drywell Pressure—High

High drywell pressure can indicate a break in the RCPB inside the primary containment. The isolation of some of the primary containment isolation valves on high drywell pressure supports actions to ensure that offsite dose limits of 10 CFR 100 are not exceeded. The Drywell Pressure—High Function, associated with isolation of the primary containment, is implicitly assumed in the FSAR accident analysis as these leakage paths are assumed to be isolated post LOCA. u

switches

High drywell pressure signals are initiated from pressure transmitters that sense the pressure in the drywell. Four

(continued)

All changes are [1] unless otherwise indicated

Primary Containment Isolation Instrumentation
B 3.3.6.1

BASES

APPLICABLE
SAFETY ANALYSES,
LCO, and
APPLICABILITY

2.b. Drywell Pressure—High (continued)

channels of Drywell Pressure—High per Function are available and are required to be OPERABLE to ensure that no single instrument failure can preclude the isolation function.

The Allowable Value was selected to be the same as the ^{scram} ~~ECES~~ Drywell Pressure—High Allowable Value (LCO 3.3.6.1), since this may be indicative of a LOCA inside primary containment. ¹ ^{RPS}

This Function isolates the Group 2, 6, 7, 10, and 12 valves.

2.c. Drywell Radiation—High

High drywell radiation indicates possible gross failure of the fuel cladding. Therefore, when Drywell Radiation—High is detected, an isolation is initiated to limit the release of fission products. However, this Function is not assumed in any accident or transient analysis in the FSAR because other leakage paths (e.g., MSIVs) are more limiting. ^U

^{capped} The drywell radiation signals are initiated from radiation detectors that are located in ~~the~~ drywell. Two channels of Drywell Radiation—High Function are available and are required to be OPERABLE to ensure that no single instrument failure can preclude the isolation function. ^{penetrations}

The Allowable Value is low enough to promptly detect gross failures in the fuel cladding.

This Function isolates the containment vent and purge valves. ^{Group 2}

2.d., 2.e. Reactor Building and Refueling Floor Exhaust Radiation—High

High secondary containment exhaust radiation is an indication of possible gross failure of the fuel cladding. The release may have originated from the primary containment due to a break in the RCPB. When Exhaust Radiation—High is detected, valves whose penetrations communicate with the primary containment atmosphere are isolated to limit the release of fission products. Additionally, the Refueling Floor Exhaust Radiation—High Function is assumed to ¹ ⁴

(continued)

BASES

APPLICABLE
SAFETY ANALYSES,
LCO, and
APPLICABILITY

2.d., 2.e. Reactor Building and Refueling Floor Exhaust
Radiation—High (continued)

initiate isolation of the primary containment during a fuel handling accident (Ref. 2).

The Exhaust Radiation—High signals are initiated from radiation detectors that are located on the ventilation exhaust piping coming from the reactor building and the refueling floor zones, respectively. The signal from each detector is input to an individual monitor whose trip outputs are assigned to an isolation channel. Four channels of Reactor Building Exhaust—High Function and four channels of Refueling Floor Exhaust—High Function are available and are required to be OPERABLE to ensure that no single instrument failure can preclude the isolation function.

The Allowable Values are chosen to promptly detect gross failure of the fuel cladding.

These Functions isolate the Group 6, 10, and 12 valves.

2.f. Manual Initiation

The Manual Initiation push button channels introduce signals into the primary containment isolation logic that are redundant to the automatic protective instrumentation and provide manual isolation capability. There is no specific FSAR safety analysis that takes credit for this Function. It is retained for overall redundancy and diversity of the isolation function as required by the NRC in the plant licensing basis.

There are two push buttons for the logic, one manual initiation push button per trip system. There is no Allowable value for this Function since the channels are mechanically actuated based solely on the position of the push buttons.

Two channels of the Manual Initiation Function are available and are required to be OPERABLE in MODES 1, 2, and 3, since these are the MODES in which the Primary Containment Isolation automatic Functions are required to be OPERABLE.

(continued)

All changes are [] unless otherwise indicated

Primary Containment Isolation Instrumentation
B 3.3.6.1

BASES

APPLICABLE SAFETY ANALYSES, LCO, and APPLICABILITY (continued)

High Pressure Coolant Injection and Reactor Core Isolation Cooling Systems Isolation

3.a., 4.a. HPCI and RCIC Steam Line Flow—High

Steam Line Flow—High Functions are provided to detect a break of the RCIC or HPCI steam lines and initiate closure of the steam line isolation valves of the appropriate system. If the steam is allowed to continue flowing out of the break, the reactor will depressurize and the core can uncover. Therefore, the isolations are initiated on high flow to prevent or minimize core damage. The isolation action, along with the scram function of the RPS, ensures that the fuel peak cladding temperature remains below the limits of 10 CFR 50.46. Specific credit for these functions is not assumed in any FSAR accident analyses since the bounding analysis is performed for large breaks such as recirculation and MSL breaks. However, these instruments prevent the RCIC or HPCI steam line breaks from becoming bounding.

(U)

differential pressure

while the RCIC Steam Line Flow—High signals are initiated by differential pressure switches

The HPCI and RCIC Steam Line Flow—High signals are initiated from transmitters (two for HPCI and two for RCIC) that are connected to the system steam lines. Two channels of both HPCI and RCIC Steam Line Flow—High Functions are available and are required to be OPERABLE to ensure that no single instrument failure can preclude the isolation function.

The Allowable Values are chosen to be low enough to ensure that the trip occurs to prevent fuel damage and maintains the MSLB event as the bounding event.

These Functions isolate the Group (4) and (5) valves, as appropriate. (C) (U)

[4]

Insert Function 3.b, 4.b

3.c., 4.b. HPCI and RCIC Steam Supply Line Pressure—Low

Low (MS) pressure indicates that the pressure of the steam in the HPCI or RCIC turbine may be too low to continue operation of the associated system's turbine. These isolations are for equipment protection and are not assumed in any transient or accident analysis in the FSAR. However, they also provide a diverse signal to indicate a possible system break. These instruments are included in Technical Specifications (TS) because of the potential for risk due to

[2]

(U)

HPCI or RCIC steam supply line [2]

(continued)

4

Insert Function 3.b, 4.b

3.b, 4.b. HPCI and RCIC Steam Line Flow-Timer

The HPCI and RCIC Steam Line Flow-Timer is provided to prevent false isolations on HPCI or RCIC Steam Line Flow-High, as applicable, during system startup transients and therefore improves system reliability. These Functions are not assumed in any UFSAR transient or accident analyses since the bounding analysis is performed for large breaks such as recirculation and MSL breaks. However, these instruments support prevention of the HPCI and RCIC steam line breaks from becoming bounding.

The HPCI and RCIC Steam Line Flow-Timer Function delays the HPCI and RCIC Steam Line Flow-High signals, respectively by use of time delay relays. When a HPCI or RCIC Steam Line Flow-High signal is generated, the time delay relays delay the tripping of the associated HPCI or RCIC isolation trip system for a short time. Two channels of both HPCI and RCIC Steam Line Flow-Timer Functions are available and are required to be OPERABLE to ensure that no single instrument failure can preclude the isolation function.

The Allowable Values are chosen to be long enough to prevent false isolations due to system starts but not so long as to impact offsite dose calculations.

These Functions, in conjunction with the HPCI and RCIC Steam Line Flow-High Functions, isolate the Group 4 and 5 valves, as appropriate.

All changes are 1 unless otherwise indicated

Primary Containment Isolation Instrumentation
B 3.3.6.1

BASES

4
C

Therefore, they meet Criterion 4 of 10 CFR 50.36(c)(2)(ii)

APPLICABLE SAFETY ANALYSES, LCO, and APPLICABILITY

3.6., 4.6.: HPCI and RCIC Steam Supply Line Pressure—Low
(continued)

while the RCIC Steam Line Pressure—Low signals are initiated from pressure switches

possible failure of the instruments preventing HPCI and RCIC initiations (Rev. 3).

pressure

The HPCI and RCIC Steam Supply Line Pressure—Low signals are initiated from transmitters (four for HPCI and four for RCIC) that are connected to the system steam line. Four channels of both HPCI and RCIC Steam Supply Line Pressure—Low Functions are available and are required to be OPERABLE to ensure that no single instrument failure can preclude the isolation function.

As noted (Note (a) to Table 3.3.6.1-1) for Function 4.c, this Function only inputs into one trip system. The trip system is connected to both RCIC steam supply isolation valves

The Allowable Values are selected to be high enough to prevent damage to the system's turbine.

These Functions isolate the Group 3 and 6 valves, as appropriate.

3.c., 4.c. HPCI and RCIC Turbine Exhaust Diaphragm Pressure—High

High turbine exhaust diaphragm pressure indicates that the pressure may be too high to continue operation of the associated system's turbine. That is, one of two exhaust diaphragms has ruptured and pressure is reaching turbine casing pressure limits. These isolations are for equipment protection and are not assumed in any transient or accident analysis in the FSAR. These instruments are included in the TS because of the potential for risk due to possible failure of the instruments preventing HPCI and RCIC initiations (Ref. 3).

The HPCI and RCIC Turbine Exhaust Diaphragm Pressure—High signals are initiated from transmitters (four for HPCI and four for RCIC) that are connected to the area between the rupture diaphragms on each system's turbine exhaust line. Four channels of both HPCI and RCIC Turbine Exhaust Diaphragm Pressure—High Functions are available and are required to be OPERABLE to ensure that no single instrument failure can preclude the isolation function.

The Allowable Values are high enough to prevent damage to the system's turbine.

(continued)

All changes are [1] unless otherwise indicated

Primary Containment Isolation Instrumentation
B 3.3.6.1

BASES

APPLICABLE SAFETY ANALYSES, LCO, and APPLICABILITY

~~3.c., 4.c. HPCI and RCIC Turbine Exhaust Diaphragm Pressure—High (continued)~~

These Functions isolate the Group 3 and 4 valves, as appropriate.

~~3.d., 4.d.~~ Drywell Pressure—High

High drywell pressure can indicate a break in the RCPB. The HPCI ~~and RCIC~~ isolation of the turbine exhaust is provided to prevent communication with the drywell when high drywell pressure exists. A potential leakage path exists via the turbine exhaust. The isolation is delayed until the system becomes unavailable for injection (i.e., low steam line pressure). The isolation of the HPCI ~~and RCIC~~ turbine exhaust by Drywell Pressure—High is indirectly assumed in the FSAR accident analysis because the turbine exhaust leakage path is not assumed to contribute to offsite doses.

u

HPCI

4

switches

High drywell pressure signals are initiated from pressure transmitters that sense the pressure in the drywell. Functions of ~~both~~ HPCI ~~and RCIC~~ Drywell Pressure—High are available and are required to be OPERABLE to ensure that no single instrument failure can preclude the isolation function.

Four

4

The Allowable Value was selected to be the same as the ECCS Drywell Pressure—High Allowable Value (LCO 3.3.9.1), since this is indicative of a LOCA inside primary containment.

This Function isolates the Group 8 ~~and 9~~ valves.

RPS

HPCI Turbine exhaust Vacuum breaker

~~3.e., 3.f., 3.h., 3.i., 4.e., 4.g., 4.h., 4.i., 4.j.~~ Area and Differential Temperature—High

HPCI and RCIC Turbine

HPCI and RCIC Turbine

Area and differential temperatures are provided to detect a leak from the associated system steam piping. The isolation occurs when a very small leak has occurred and is diverse to the high flow instrumentation. If the small leak is allowed to continue without isolation, offsite dose limits may be reached. These Functions are not assumed in any FSAR transient or accident analysis, since bounding analyses are performed for large breaks such as recirculation or MSL breaks.

4

4

(continued)

All changes are [1] unless otherwise indicated

Primary Containment Isolation Instrumentation
B 3.3.6.1 [4]

BASES

APPLICABLE SAFETY ANALYSES, LCO, and APPLICABILITY

3.e., 3.f., 3.h., 3.i., 4.a., 4.g., 4.h., 4.i., 4.j. Area and Differential Temperature—High (continued)

HPCI and RCIC Turbine [4]

and four channels monitor each HPCI area [4]

HPCI and RCIC Turbine

detect a leak from the system piping

Turbine

Area and Differential Temperature—High signals are initiated from thermocouples that are appropriately located to protect the system that is being monitored. Two instruments monitor each area. Two channels for each HPCI and RCIC Area and Differential Temperature—High Functions are available and are required to be OPERABLE to ensure that no single instrument failure can preclude the isolation function.

Four

Eight thermocouples provide input to the Area Ventilation Differential Temperature—High Function. The output of these thermocouples is used to determine the differential temperature. Each channel consists of a differential temperature instrument that receives inputs from thermocouples that are located in the inlet and outlet of the area cooling system for a total of four available channels (two for RCIC and two for HPCI)

[1]

[4]

The Allowable Values are set low enough to detect a leak equivalent to 25 gpm.

These Functions isolate the Group 4 and 5 valves, as appropriate.

[4]

[5]

3.g., 4.f. Suppression Pool Area Temperature—Time Delay Relay

[1]

The Suppression Pool Area Temperature—Time Delay Relays are provided to allow all the other systems that may be leaking into the pool area (as indicated by the high temperature) to be isolated before HPCI and/or RCIC are automatically isolated. This ensures maximum HPCI and RCIC System operation by preventing isolations due to leaks in other systems. These Functions are not assumed in any FSAR transient or accident analysis.

[4]

There are four time delay relays (two for HPCI and two for RCIC). Two channels each for both HPCI and RCIC Suppression Pool Area Temperature—Time Delay Relay Functions are available and are required to be OPERABLE to ensure that no single instrument failure can preclude the isolation function.

(continued)

BASES

APPLICABLE
SAFETY ANALYSES,
LCO, and
APPLICABILITY

3.g., 4.f. Suppression Pool Area Temperature—Time Delay Relay (continued)

The Allowable Values are based on maximizing the availability of the HPCI and RCIC systems. That is, they provide sufficient time to isolate all other potential leakage sources in the suppression pool area before HPCI and RCIC are isolated.

These Functions isolate the Group 3 and 4 valves, as appropriate.

3.i., 4.k. Manual Initiation

The Manual Initiation push button channels introduce signals into the HPCI and RCIC systems' isolation logics that are redundant to the automatic protective instrumentation and provide manual isolation capability. There is no specific FSAR safety analysis that takes credit for these Functions. They are retained for overall redundancy and diversity of the isolation function as required by the NRC in the plant licensing basis.

There are two push buttons for each of the logics (HPCI and RCIC), one manual initiation push button per trip system. There is no Allowable Value for these Functions, since the channels are mechanically actuated based solely on the position of the push buttons.

Two channels of both HPCI and RCIC Manual Initiation Functions are available and are required to be OPERABLE in MODES 1, 2, and 3 since these are the MODES in which the HPCI and RCIC systems' Isolation automatic Functions are required to be OPERABLE.

Reactor Water Cleanup System Isolation

5.a. Differential Flow—High

The high differential flow signal is provided to detect a break in the RWCU System. This will detect leaks in the RWCU System when area or differential temperature would not provide detection (i.e., a cold leg break). Should the reactor coolant continue to flow out of the break, offsite dose limits may be exceeded. Therefore, isolation of the

(continued)

BASES

APPLICABLE
SAFETY ANALYSES,
LCO, and
APPLICABILITY

5.a. Differential Flow—High (continued)

RWCU System is initiated when high differential flow is sensed to prevent exceeding offsite doses. A time delay is provided to prevent spurious trips during most RWCU operational transients. This Function is not assumed in any FSAR transient or accident analysis, since bounding analyses are performed for large breaks such as MSLBs.

The high differential flow signals are initiated from transmitters that are connected to the inlet (from the reactor vessel) and outlets (to condenser and feedwater) of the RWCU System. The outputs of the transmitters are compared (in a common summer) and the resulting output is sent to two high flow trip units. If the difference between the inlet and outlet flow is too large, each trip unit generates an isolation signal. Two channels of Differential Flow—High Function are available and are required to be OPERABLE to ensure that no single instrument failure downstream of the common summer can preclude the isolation function.

The Differential Flow—High Allowable Value ensures that a break of the RWCU piping is detected.

This Function isolates the Group 5 valves.

5.b., 5.c. Area and Area Ventilation Differential Temperature—High

RWCU area and area ventilation differential temperatures are provided to detect a leak from the RWCU System. The isolation occurs even when very small leaks have occurred and is diverse to the high differential flow instrumentation for the hot portions of the RWCU System. If the small leak continues without isolation, offsite dose limits may be reached. Credit for these instruments is not taken in any transient or accident analysis in the FSAR, since bounding analyses are performed for large breaks such as recirculation or MSL breaks.

Area and area ventilation differential temperature signals are initiated from temperature elements that are located in the room that is being monitored. Six thermocouples provide input to the Area Temperature—High Function (two per area). Six channels are required to be OPERABLE to ensure that no

(continued)

All changes are [1] unless otherwise indicated.

Primary Containment Isolation Instrumentation
B 3.3.6.1

BASES

APPLICABLE
SAFETY ANALYSES,
LCO, and
APPLICABILITY

5.b., 5.c. Area and Area Ventilation Differential
Temperature—High (continued)

single instrument failure can preclude the isolation function.

Twelve thermocouples provide input to the Area Ventilation Differential Temperature—High Function. The output of these thermocouples is used to determine the differential temperature. Each channel consists of a differential temperature instrument that receives inputs from thermocouples that are located in the inlet and outlet of the area cooling system and for a total of six available channels (two per area). Six channels are required to be OPERABLE to ensure that no single instrument failure can preclude the isolation function.

The Area and Area Ventilation Differential Temperature—High Allowable Values are set low enough to detect a leak equivalent to 25 gpm.

These Functions isolate the Group 5 valves.

5.d. SLC System Initiation

The isolation of the RWCU System is required when the SLC System has been initiated to prevent dilution and removal of the boron solution by the RWCU System (Ref. (a)). SLC System initiation signals are initiated from the ~~two SLC pump start~~ signals. (b)

There is no Allowable Value associated with this Function since the channels are mechanically actuated based solely on the position of the SLC System initiation switch. (2)

Two channels (~~one from each pump~~) of the SLC System Initiation Function are available and are required to be OPERABLE only in MODES 1 and 2, since these are the only MODES where the reactor can be critical, and these MODES are consistent with the Applicability for the SLC System (LCO 3.1.7).

As noted (footnote (b) to Table 3.3.6.1-1), this Function is only required to close one of the RWCU isolation valves since the signals only provide input into one of the two trip systems.

This Function isolates
the Group 3 valves

(continued)

4
a
SLC initiation
switch

All changes are 1 unless otherwise indicated

Primary Containment Isolation Instrumentation
B 3.3.6.1

BASES

APPLICABLE
SAFETY ANALYSES,
LCO, and
APPLICABILITY
(continued)

b — 4

5.e. Reactor Vessel Water Level—Low (Low/Level 2) 4

low RPV
water level
4

Low RPV water level indicates that the capability to cool the fuel may be threatened. Should RPV water level decrease too far, fuel damage could result. Therefore, isolation of some interfaces with the reactor vessel occurs to isolate the potential sources of a break. The isolation of the RVCU System on Level 2 supports actions to ensure that the fuel peak cladding temperature remains below the limits of 10 CFR 50.46. The Reactor Vessel Water Level—Low Low/Level 2 Function associated with RVCU isolation is not directly assumed in the FSAR safety analyses because the RVCU System line break is bounded by breaks of larger systems (recirculation and MSJ breaks are more limiting). 4

differential
pressure

Reactor Vessel Water Level—Low Low/Level 2 signals are initiated from four Level 2 transmitters that sense the difference between the pressure due to a constant column of water (reference leg) and the pressure due to the actual water level (variable leg) in the vessel. Four channels of Reactor Vessel Water Level—Low Low/Level 2 Function are available and are required to be OPERABLE to ensure that no single instrument failure can preclude the isolation function. 4

The Reactor Vessel Water Level—Low Low/Level 2 Allowable Value was chosen to be the same as the EPDS Reactor Vessel Water Level—Low Low/Level 2 Allowable Value (LCO 3.3.6.1), since the capability to cool the fuel may be threatened. RPS 4

This Function isolates the Group 3 valves. 4

5.f. Manual Initiation 3

The Manual Initiation push button channels introduce signals into the RVCU System isolation logic that are redundant to the automatic protective instrumentation and provide manual isolation capability. There is no specific FSAR safety analysis that takes credit for this Function. It is retained for overall redundancy and diversity of the isolation function as required by the NRC in the plant licensing basis. 1

There are two push buttons for the logic, one manual initiation push button per trip system. There is no Allowable Value for this Function, since the channels are 4

(continued)

All changes are [] unless otherwise indicated

Primary Containment Isolation Instrumentation
B 3.3.6.1

BASES

APPLICABLE SAFETY ANALYSES, LCO, and APPLICABILITY

5.f. Manual Initiation (continued)

mechanically actuated based solely on the position of the push buttons.

Two channels of the Manual Initiation Function are available and are required to be OPERABLE in MODES 1, 2, and 3 since these are the MODES in which the RWCU System Isolation automatic functions are required to be OPERABLE.

[1]

[4]

[4]

[2] Residual Heat Removal (RHR)

Shutdown Cooling System Isolation (SDC) [2]

Vessel

6.a. Reactor Steam Dome Pressure-High

(both providing input into two trip systems)

The Reactor Steam Dome Pressure-High Function is provided to isolate the shutdown cooling portion of the Residual Heat Removal (RHR) System. This interlock is provided only for equipment protection to prevent an intersystem LOCA scenario, and credit for the interlock is not assumed in the accident or transient analysis in the FSAR.

[4] Vessel

The Reactor Steam Dome Pressure-High signals are initiated from two transmitters that are connected to different taps on the RPV. Two channels of Reactor Steam Dome Pressure-High Function are available and are required to be OPERABLE to ensure that no single instrument failure can preclude the isolation function. The Function is only required to be OPERABLE in MODES 1, 2, and 3, since these are the only MODES in which the reactor can be pressurized; thus, equipment protection is needed. The Allowable Value was chosen to be low enough to protect the system equipment from overpressurization.

pressure switches

Reactor recirculation loop B suction line

[4] Vessel

This Function isolates the Group 1 valves.

residual heat removal shutdown cooling suction and injection

6.b. Reactor Vessel Water Level-Low Level 3 [4]

Low RPV water level indicates that the capability to cool the fuel may be threatened. Should RPV water level decrease too far, fuel damage could result. Therefore, isolation of some reactor vessel interfaces occurs to begin isolating the potential sources of a break. The Reactor Vessel Water Level-Low Level 3 Function associated with RHR Shutdown Cooling System isolation is not directly assumed in safety analyses because a break of the RHR Shutdown Cooling System

[4]

(continued)

All changes are [1] unless otherwise indicated

Primary Containment Isolation Instrumentation
B 3.3.6.1

BASES

APPLICABLE
SAFETY ANALYSES,
LCO, and
APPLICABILITY

6.b. Reactor Vessel Water Level—Low Level 3 (continued)

is bounded by breaks of the recirculation and MSL. The RHR Shutdown Cooling System isolation on Level 3 supports actions to ensure that the RPV water level does not drop below the top of the active fuel during a vessel draindown event caused by a leak (e.g., pipe break or inadvertent valve opening) in the RHR Shutdown Cooling System.

low RPV water level

differential pressure

Reactor Vessel Water Level—Low Level 3 signals are initiated from four Level 3 transmitters that sense the difference between the pressure due to a constant column of water (reference leg) and the pressure due to the actual water level (variable leg) in the vessel. Four channels (two channels per trip system) of the Reactor Vessel Water Level—Low Level 3 Function are available and are required to be OPERABLE to ensure that no single instrument failure can preclude the isolation function. As noted (footnote (a) to Table 3.3.6.1-1), only two channels of the Reactor Vessel Water Level—Low, Level 3 Function are required to be OPERABLE in MODES 4 and 5 (and must input into the same trip system), provided the RHR Shutdown Cooling System integrity is maintained. System integrity is maintained provided the piping is intact and no maintenance is being performed that has the potential for draining the reactor vessel through the system.

Insert 6.b

The Reactor Vessel Water Level—Low Level 3 Allowable Value was chosen to be the same as the RPS Reactor Vessel Water Level—Low Level 3 Allowable Value (LCO 3.3.1.1), since the capability to cool the fuel may be threatened.

The Reactor Vessel Water Level—Low Level 3 Function is only required to be OPERABLE in MODES 3, 4, and 5 to prevent this potential flow path from lowering the reactor vessel level to the top of the fuel. In MODES 1 and 2, another isolation (i.e., Reactor Steam Dome Pressure—High) and administrative controls ensure that this flow path remains isolated to prevent unexpected loss of inventory via this flow path.

This Function isolates the Group 1 valves.

residual heat removal shutdown cooling suction and injection

(continued)

1

Insert 6.b

only one channel per trip system (with an isolation signal available to one shutdown cooling pump suction isolation valve) of the Reactor Vessel Water Level-Low Function is required to be OPERABLE in MODES 4 and 5, provided the Shutdown Cooling System integrity is maintained. System integrity is maintained provided the piping is intact and no maintenance is being performed that has the potential for draining the reactor vessel through the system.

BASES (continued)

ACTIONS

Reviewer's Note: Certain LCO Completion Times are based on approved topical reports. In order for a licensee to use the times, the licensee must justify the Completion Times as required by the staff Safety Evaluation Report (SER) for the topical report.

A Note has been provided to modify the ACTIONS related to primary containment isolation instrumentation channels. Section 1.3, Completion Times, specifies that once a Condition has been entered, subsequent divisions, subsystems, components, or variables expressed in the Condition, discovered to be inoperable or not within limits, will not result in separate entry into the Condition. Section 1.3 also specifies that Required Actions of the Condition continue to apply for each additional failure, with Completion Times based on initial entry into the Condition. However, the Required Actions for inoperable primary containment isolation instrumentation channels provide appropriate compensatory measures for separate inoperable channels. As such, a Note has been provided that allows separate Condition entry for each inoperable primary containment isolation instrumentation channel.

A.1

Because of the diversity of sensors available to provide isolation signals and the redundancy of the isolation design, an allowable out of service time of 12 hours for functions 2.a, 2.b, and 6.b and 24 hours for functions other than functions 2.a, 2.b, and 6.b has been shown to be acceptable (Refs. 5 and 6) to permit restoration of any inoperable channel to OPERABLE status. This out of service time is only acceptable provided the associated function is still maintaining isolation capability (refer to Required Action B.1 Bases). If the inoperable channel cannot be restored to OPERABLE status within the allowable out of service time, the channel must be placed in the tripped condition per Required Action A.1. Placing the inoperable channel in trip would conservatively compensate for the inoperability, restore capability to accommodate a single failure, and allow operation to continue with no further restrictions. Alternately, if it is not desired to place the channel in trip (e.g., as in the case where placing the inoperable channel in trip would result in an isolation), Condition C must be entered and its Required Action taken.

depending on the function (12 hours for those functions that have channel components common to RPS instrumentation and 24 hours for those functions that do not have channel components common to RPS instrumentation)



(continued)

All changes are I unless otherwise indicated

Primary Containment Isolation Instrumentation
B 3.3.6.1

BASES

ACTIONS
(continued)

B.1

and Primary Containment

Required Action B.1 is intended to ensure that appropriate actions are taken if multiple, inoperable, untripped channels within the same Function result in redundant automatic isolation capability being lost for the associated penetration flow path(s). The MSL Isolation Functions are considered to be maintaining isolation capability when sufficient channels are OPERABLE or in trip, such that both trip systems will generate a trip signal from the given Function on a valid signal. and portions of other system Isolation Functions

The HPCI, RCIC and portions of other system Isolation Functions

1.c are considered to be maintaining isolation capability when sufficient channels are OPERABLE or in trip, such that one trip system will generate a trip signal from the given Function on a valid signal. This ensures that one of the two PCIVs in the associated penetration flow path can receive an isolation signal from the given Function. For Functions 1.a, 1.b, 1.d, and 1.g, this would require both trip systems to have one channel OPERABLE or in trip. For Function 1.c, this would require both trip systems to have one channel, associated with each MSL, OPERABLE or in trip. (associated with HPCI steam supply isolation), B.e.

2.a, 2.b, 2.c, 5.b, 6.a and 6.b

For Functions 1.e and 1.f, each Function consists of channels that monitor several locations within a given area (e.g., different locations within the main steam tunnel area). Therefore, this would require both trip systems to have one channel per location OPERABLE or in trip. For Functions 2.a, 2.b, 2.c, 2.e, 3.b, 3.c, 4.a, 4.b, 4.c, 4.d, 4.e, 4.f, 4.g, 4.h, 4.i, 4.j, 5.a, 5.d, and 6.a, this would require one trip system to have one channel OPERABLE or in trip. For Functions 3.a, 3.d, 3.e, 3.f, 3.g, 3.h, 3.i, 4.a, 4.d, 4.e, 4.f, 4.g, 4.h, 4.i, 4.j, 5.a, 5.d, and 6.a, this would require one trip system to have one channel OPERABLE or in trip. For Functions 5.b and 5.c, each Function consists of channels that monitor several different locations. Therefore, this would require one channel per location to be OPERABLE or in trip (the channels are not required to be in the same trip system). The Condition does not include the Manual Initiation Functions (Functions 1.h, 2.d, 3.j, 4.k, and 5.f), since they are not assumed in any accident or transient analysis. Thus, a total loss of manual initiation capability for 24 hours (as allowed by Required Action A.1) is allowed.

However, any channel in any of the four areas is able to detect a leak.

4.d

3.a, 4.b, and 5.a

For Function 4.c, this would require two or more channels to be OPERABLE or in trip in the trip system.

The Condition does not include the Manual Initiation Functions (Functions 1.h, 2.d, 3.j, 4.k, and 5.f), since they are not assumed in any accident or transient analysis. Thus, a total loss of manual initiation capability for 24 hours (as allowed by Required Action A.1) is allowed.

3.b, 3.c (associated with HPCI vacuum breaker isolation)

The Completion Time is intended to allow the operator time to evaluate and repair any discovered inoperabilities. The 1 hour Completion Time is acceptable because it minimizes

(continued)

BASES

ACTIONS

B.1 (continued)

risk while allowing time for restoration or tripping of channels.

C.1

Required Action C.1 directs entry into the appropriate Condition referenced in Table 3.3.6.1-1. The applicable Condition specified in Table 3.3.6.1-1 is Function and MODE or other specified condition dependent and may change as the Required Action of a previous Condition is completed. Each time an inoperable channel has not met any Required Action of Condition A or B and the associated Completion Time has expired, Condition C will be entered for that channel and provides for transfer to the appropriate subsequent Condition.

2
This Required Action will generally only be used if a Function i.c. channel is inoperable and untripped. The associated MS(s) to be isolated are those whose Main Steam Line Flow - High Function channel(s) are inoperable. Alternately,

D.1, D.2.1, and D.2.2

If the channel is not restored to OPERABLE status or placed in trip within the allowed Completion Time, the plant must be placed in a MODE or other specified condition in which the LCO does not apply. This is done by placing the plant in at least MODE 3 within 12 hours and in MODE 4 within 36 hours (Required Actions D.2.1 and D.2.2). Alternately, the associated MSLs may be isolated (Required Action D.1), and, if allowed (i.e., plant safety analysis allows operation with an MSL isolated), operation with that MSL isolated may continue. Isolating the affected MSL accomplishes the safety function of the inoperable channel. The Completion Times are reasonable, based on operating experience, to reach the required plant conditions from full power conditions in an orderly manner and without challenging plant systems.

E.1

If the channel is not restored to OPERABLE status or placed in trip within the allowed Completion Time, the plant must be placed in a MODE or other specified condition in which the LCO does not apply. This is done by placing the plant in at least MODE 2 within 6 hours.

3 4

(continued)

BASES

ACTIONS

E.1 (continued)

③ ————— ④

The allowed Completion Time of ③ hours is reasonable, based on operating experience, to reach MODE 2 from full power conditions in an orderly manner and without challenging plant systems.

E.1

If the channel is not restored to OPERABLE status or placed in trip within the allowed Completion Time, plant operations may continue if the affected penetration flow path(s) is isolated. Isolating the affected penetration flow path(s) accomplishes the safety function of the inoperable channel. ②

For the RVCU Area and Area Ventilation Differential Temperature—High Functions, the affected penetration flow path(s) may be considered isolated by isolating only that portion of the system in the associated room monitored by the inoperable channel. That is, if the RVCU pump room A area channel is inoperable, the pump room A area can be isolated while allowing continued RVCU operation utilizing the B RVCU pump. For the RVCU Differential Flow—High Function, if the flow element/transmitter monitoring RVCU flow to radwaste and condensate is the only portion of the channel inoperable, then the affected penetration flow path(s) may be considered isolated by isolating the RVCU return to radwaste and condensate. ① ④

Alternately, if it is not desired to isolate the affected penetration flow path(s) (e.g., as in the case where isolating the penetration flow path(s) could result in a reactor scram), Condition H must be entered and its Required Actions taken.

The 1 hour Completion Time is acceptable because it minimizes risk while allowing sufficient time for plant operations personnel to isolate the affected penetration flow path(s).

G.1

④

If the channel is not restored to OPERABLE status or placed in trip within the allowed Completion Time, plant operations

(continued)

BASES

ACTIONS

G.1 (continued)

may continue if the affected penetration flow path(s) is isolated. Isolating the affected penetration flow path(s) accomplishes the safety function of the inoperable channels. The 24 hour Completion Time is acceptable due to the fact that these Functions (Manual Initiation) are not assumed in any accident or transient analysis in the FSAR. Alternately, if it is not desired to isolate the affected penetration flow path(s) (e.g., as in the case where isolating the penetration flow path(s) could result in a reactor scram), Condition H must be entered and its Required Actions taken.

4 - 6

H.1 and H.2

If the channel is not restored to OPERABLE status or placed in trip within the allowed Completion Time, or any Required Action of Condition F ~~or G~~ is not met and the associated Completion Time has expired, the plant must be placed in a MODE or other specified condition in which the LCO does not apply. This is done by placing the plant in at least MODE 3 within 12 hours and in MODE 4 within 36 hours. The allowed Completion Times are reasonable, based on operating experience, to reach the required plant conditions from full power conditions in an orderly manner and without challenging plant systems.

4 - H

A.1 and A.2

If the channel is not restored to OPERABLE status or placed in trip within the allowed Completion Time, the associated SLC subsystem(s) is declared inoperable or the RWCU System is isolated. Since this Function is required to ensure that the SLC System performs its intended function, sufficient remedial measures are provided by declaring the associated SLC subsystems inoperable or isolating the RWCU System.

The 1 hour Completion Time is acceptable because it minimizes risk while allowing sufficient time for personnel to isolate the RWCU System.

(continued)

BASES

ACTIONS
(continued)

3.1 and 3.2 (1) (4)

If the channel is not restored to OPERABLE status or placed in trip within the allowed Completion Time, the associated penetration flow path should be closed. However, if the shutdown cooling function is needed to provide core cooling, these Required Actions allow the penetration flow path to remain unisolated provided action is immediately initiated to restore the channel to OPERABLE status or to isolate the RHR Shutdown Cooling System (i.e., provide alternate decay heat removal capabilities so the penetration flow path can be isolated). Actions must continue until the channel is restored to OPERABLE status or the RHR Shutdown Cooling System is isolated.

SURVEILLANCE
REQUIREMENTS

Reviewer's Note: Certain Frequencies are based on approved topical reports. In order for a licensee to use these Frequencies, the licensee must justify the Frequencies as required by the staff SER for the topical report. (5)

As noted at the beginning of the SRs, the SRs for each Primary Containment Isolation instrumentation Function are found in the SRs column of Table 3.3.6.1-1.

The Surveillances are modified by a Note to indicate that when a channel is placed in an inoperable status solely for performance of required Surveillances, entry into associated Conditions and Required Actions may be delayed for up to 6 hours provided the associated Function maintains ~~CFD~~ isolation (3) capability. Upon completion of the Surveillance, or expiration of the 6 hour allowance, the channel must be returned to OPERABLE status or the applicable Condition entered and Required Actions taken. This Note is based on (9) the reliability analysis (Refs. 5 and 6) assumption of the average time required to perform channel surveillance. That analysis demonstrated that the 6 hour testing allowance does not significantly reduce the probability that the PCIVs will isolate the penetration flow path(s) when necessary. (10) (1)

SR 3.3.6.1.1

Performance of the CHANNEL CHECK once every 12 hours ensures that a gross failure of instrumentation has not occurred. A

(continued)

BASES

SURVEILLANCE
REQUIREMENTS

SR 3.3.6.1.1 (continued)

CHANNEL CHECK is normally a comparison of the parameter indicated on one channel to a similar parameter on other channels. It is based on the assumption that instrument channels monitoring the same parameter should read approximately the same value. Significant deviations between the instrument channels could be an indication of excessive instrument drift in one of the channels or of something even more serious. A CHANNEL CHECK will detect gross channel failure; thus, it is key to verifying the instrumentation continues to operate properly between each CHANNEL CALIBRATION.

Agreement criteria are determined by the plant staff based on a combination of the channel instrument uncertainties, including indication and readability. If a channel is outside the criteria, it may be an indication that the instrument has drifted outside its limit.

The Frequency is based on operating experience that demonstrates channel failure is rare. The CHANNEL CHECK supplements less formal, but more frequent, checks of channels during normal operational use of the displays associated with the channels required by the LCO.

SR 3.3.6.1.2 and SR 3.3.6.1.5 (4)

A CHANNEL FUNCTIONAL TEST is performed on each required channel to ensure that the ~~entire~~ channel will perform the intended function. (2)

(2) Any setpoint adjustment shall be consistent with the assumptions of the current plant specific setpoint methodology.

The 92 day Frequency of SR 3.3.6.1.2 is based on the reliability analysis described in References (9) and (10). The 184 day Frequency of SR 3.3.6.1.5 is based on engineering judgment and the reliability of the components (time delay relays exhibit minimal drift). (4)

(continued)

BASES

**SURVEILLANCE
REQUIREMENTS**
(continued)

SR 3.3.6.1.3

Calibration of trip units provides a check of the actual trip setpoints. The channel must be declared inoperable if the trip setting is discovered to be less conservative than the Allowable Value specified in Table 3.3.6.1-1. If the trip setting is discovered to be less conservative than accounted for in the appropriate setpoint methodology, but is not beyond the Allowable Value, the channel performance is still within the requirements of the plant safety analysis. Under these conditions, the setpoint must be readjusted to be equal to or more conservative than that accounted for in the appropriate setpoint methodology.

The Frequency of 92 days is based on the reliability analysis of References 9 and 10.

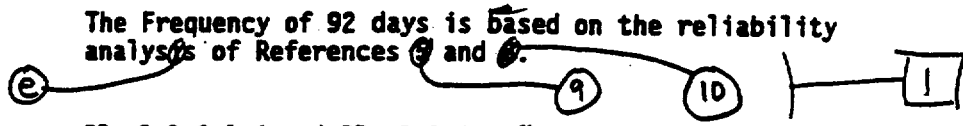

SR 3.3.6.1.4 and SR 3.3.6.1.6

A CHANNEL CALIBRATION is a complete check of the instrument loop and the sensor. This test verifies the channel responds to the measured parameter within the necessary range and accuracy. CHANNEL CALIBRATION leaves the channel adjusted to account for instrument drifts between successive calibrations consistent with the plant specific setpoint methodology.

The Frequency of SR 3.3.6.1.4 is based on the assumption of a 92 day calibration interval in the determination of the magnitude of equipment drift in the setpoint analysis. The Frequency of SR 3.3.6.1.6 is based on the assumption of a 18 month calibration interval in the determination of the magnitude of equipment drift in the setpoint analysis.

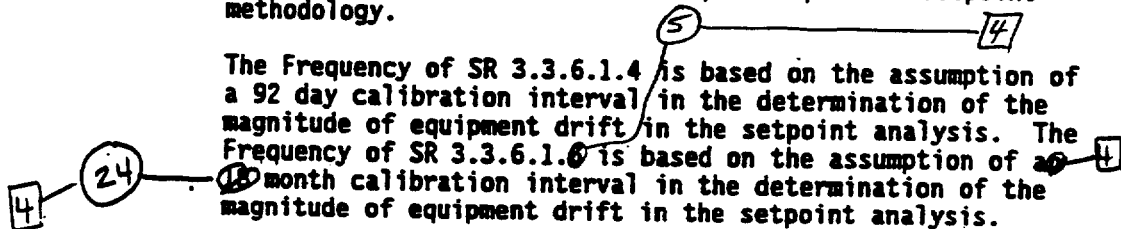

SR 3.3.6.1.7

The LOGIC SYSTEM FUNCTIONAL TEST demonstrates the OPERABILITY of the required isolation logic for a specific channel. The system functional testing performed on PCIVs in LCO 3.6.1.3 overlaps this Surveillance to provide complete testing of the assumed safety function. The 24 month Frequency is based on the need to perform this Surveillance under the conditions that apply during a plant outage and the potential for an unplanned transient if the



(continued)

BASES

SR 3.3.6.1.6 (continued)

SURVEILLANCE
REQUIREMENTS

Surveillance under the conditions that apply during a plant outage and the potential for an unplanned transient if the

SR 3.3.6.1.7 (continued)

Surveillance were performed with the reactor at power. Operating experience has shown these components usually pass the Surveillance when performed at the 18 month Frequency.

SR 3.3.6.1.8

This SR ensures that the individual channel response times are less than or equal to the maximum values assumed in the accident analysis. Testing is performed only on channels where the assumed response time does not correspond to the diesel generator (DG) start time. For channels assumed to respond within the DG start time, sufficient margin exists in the [10] second start time when compared to the typical channel response time (milliseconds) so as to assure adequate response without a specific measurement test. The instrument response times must be added to the PCIV closure times to obtain the ISOLATION SYSTEM RESPONSE TIME.

ISOLATION SYSTEM RESPONSE TIME acceptance criteria are included in Reference 7. This test may be performed in one measurement, or in overlapping segments, with verification that all components are tested.

A Note to the Surveillance states that the radiation detectors may be excluded from ISOLATION SYSTEM RESPONSE TIME testing. This Note is necessary because of the difficulty of generating an appropriate detector input signal and because the principles of detector operation virtually ensure an instantaneous response time. Response times for radiation detector channels shall be measured from detector output or the input of the first electronic component in the channel.

ISOLATION SYSTEM RESPONSE TIME tests are conducted on an 18 month STAGGERED TEST BASIS. The 18 month Frequency is consistent with the typical industry refueling cycle and is based upon plant operating experience that shows that random failures of instrumentation components causing serious response time degradation, but not channel failure, are infrequent occurrences.

(continued)

All changes are 1 unless otherwise indicated

Primary Containment Isolation Instrumentation
B 3.3.6.1

BASES (continued)

REFERENCES

1

③ → ④. ④) FSAR, Section ~~16.01~~. ②

④ → ⑤. ④) FSAR, Chapter ~~15~~. 7

3. NEDO-31486, "Technical Specification Screening Criteria Application and Risk Assessment," November 1987.

⑧ → ④. ④) FSAR, Section ~~6.2.3.4.3~~. 7 9.3.5

⑨ → ⑩. NEDC-31677P-A, "Technical Specification Improvement Analysis for BWR Isolation Actuation Instrumentation," July 1990.

⑩ → ⑪. NEDC-30851P-A Supplement 2, "Technical Specifications Improvement Analysis for BWR Isolation Instrumentation Common to RPS and ECCS Instrumentation," March 1989.

7. FSAR, Section [7.3]. 4

1. VFSAR, Table 6.2-7.

2. 10 CFR 50.62.

5. VFSAR, Section 15.6.5.

6. VFSAR, Section 15.1.3.

7. VFSAR, Section 15.6.4.

JUSTIFICATION FOR DEVIATIONS FROM NUREG-1433, REVISION 1
ITS BASES: 3.3.6.1 - PRIMARY CONTAINMENT ISOLATION INSTRUMENTATION

1. Changes have been made (additions, deletions, and/or changes to the NUREG) to reflect the plant specific methodology, nomenclature, number, reference, system description, analysis description, or licensing basis description.
2. Editorial change made for enhanced clarity or to be consistent with similar statements in other places in the Bases.
3. Changes have been made to more closely reflect the Specification requirements.
4. Changes have been made to reflect those changes made to the Specification. The following requirements have been renumbered, where applicable, to reflect the changes.
5. This Reviewer's Note has been deleted. This information is for the NRC reviewer to be keyed in to what is needed to meet this requirement. This is not meant to be retained in the final version of the plant specific submittal.
6. Typographical/grammatical/format error corrected.
7. The brackets have been removed and the proper plant specific information/value has been provided.

B 3.3 INSTRUMENTATION

B 3.3.6.2 Secondary Containment Isolation Instrumentation

BASES All changes are unless otherwise indicated

BACKGROUND

The secondary containment isolation instrumentation automatically initiates closure of appropriate secondary containment isolation valves (SCIVs) and starts the Standby Gas Treatment (SGT) System. The function of these systems, in combination with other accident mitigation systems, is to limit fission product release during and following postulated Design Basis Accidents (DBAs) (Ref. 1). Secondary containment isolation and establishment of vacuum with the SGT System ~~within the assumed time limits~~ ensures that fission products that leak from primary containment following a DBA, or are released outside primary containment, or are released during certain operations when primary containment is not required to be OPERABLE are maintained within applicable limits. 3

The isolation instrumentation includes the sensors, relays, and switches that are necessary to cause initiation of secondary containment isolation. Most channels include electronic equipment (e.g., trip units) that compares measured input signals with pre-established setpoints. When the setpoint is exceeded, the channel output relay actuates, which then outputs a secondary containment isolation signal to the isolation logic. Functional diversity is provided by monitoring a wide range of independent parameters. The input parameters to the isolation logic are (1) reactor vessel water level, (2) drywell pressure, (3) reactor building exhaust, and (4) refueling floor ~~exhaust~~ high radiation. Redundant sensor input signals from each parameter are provided for initiation of isolation. ~~In addition, manual initiation of the logic is provided.~~

high radiation

The outputs of the logic channels in a trip system are arranged into two one-out-of-two trip system logics. One trip system initiates isolation of one automatic isolation valve (damper) and starts one SGT subsystem while the other trip system initiates isolation of the other automatic isolation valve in the penetration and starts the other SGT subsystem. Each logic closes one of the two valves on each penetration and starts one SGT subsystem, so that operation of either logic isolates the secondary containment and provides for the necessary filtration of fission products.

Insert BKGD-1

1

Insert BKGD-1

For both the Reactor Vessel Water Level - Low and Drywell Pressure - High Function, the secondary containment isolation logic receives input from four channels. One channel associated with each Function inputs to one of four trip strings. Two trip strings make up a trip system and both trip systems must trip to initiate the secondary containment isolation function. Any channel will trip the associated trip string. Any trip string will trip the associated trip system. The trip strings are arranged in a one-out-of-two taken twice logic to initiate the secondary containment isolation function. For both Reactor Building Exhaust Radiation - High and Refueling Floor Radiation - High Functions, the secondary containment isolation trip system logic receives input from four channels. Two channels of Reactor Building Exhaust Radiation - High are located in each of the unit reactor building exhaust ducts and two channels of Refueling Floor Radiation - High are located where they can monitor the environment of each of the unit spent fuel pools. The output of the channels associated with Unit 1 are provided to one trip system while the output of the channels associated with Unit 2 are provided to the other trip system. The output from these channels are arranged in two one-out-of-two trip system logics for each Function to initiate the secondary containment isolation function. Any Reactor Building Exhaust Radiation - High or Refueling Floor Radiation - High channels will initiate the secondary containment isolation function. Initiating the secondary containment isolation function provides an input to both secondary containment Train A and Train B logic. Either train initiates isolation of all secondary containment isolation valves and provides a start signal to the associated SGT subsystem.

BASES (continued)

APPLICABLE
SAFETY ANALYSES,
LCO, and
APPLICABILITY

The isolation signals generated by the secondary containment instrumentation are (implicitly) assumed in the safety analyses of References 1 and 2 to initiate closure of valves and start the SGT System to limit offsite doses.

the SCIVs

Refer to LCO 3.6.4.2, "Secondary Containment Isolation Valves (SCIVs)," and LCO 3.6.4.3, "Standby Gas Treatment (SGT) System," Applicable Safety Analyses Bases for more detail of the safety analyses.

The secondary containment instrumentation satisfies Criterion 3 of ~~the NRC Policy Statement~~. Certain instrumentation Functions are retained for other reasons and are described below in the individual Functions discussion.

The OPERABILITY of the secondary containment isolation instrumentation is dependent on the OPERABILITY of the individual instrumentation channel Functions. Each Function must have the required number of OPERABLE channels with their setpoints set within the specified Allowable Values, as shown in Table 3.3.6.2-1. The actual setpoint is calibrated consistent with applicable setpoint methodology assumptions. A channel is inoperable if its actual trip setpoint is not within its required Allowable Value. Each channel must also respond within its assumed response time where appropriate.

Allowable Values are specified for each Function specified in the Table. Nominal trip setpoints are specified in the setpoint calculations. The nominal setpoints are selected to ensure that the setpoints do not exceed the Allowable Value between CHANNEL CALIBRATIONS. Operation with a trip setpoint less conservative than the nominal trip setpoint, but within its Allowable Value, is acceptable.

Trip setpoints are those predetermined values of output at which an action should take place. The setpoints are compared to the actual process parameter (e.g., reactor vessel water level), and when the measured output value of the process parameter exceeds the setpoint, the associated device (e.g., trip unit) changes state. The analytic limits are derived from the limiting values of the process parameters obtained from the safety analysis. The Allowable Values are derived from the analytic limits, corrected for calibration, process, and some of the instrument errors. The trip setpoints are then determined accounting for the

Insert
ASA

(continued)

BASES

All changes of □ unless otherwise indicated

APPLICABLE
SAFETY ANALYSES,
LCD, and
APPLICABILITY
(continued)

remaining instrument errors (e.g., drift). The trip setpoints derived in this manner provide adequate protection because instrumentation uncertainties, process effects, calibration tolerances, instrument drift, and severe environment errors (for channels that must function in harsh environments as defined by 10 CFR 50.49) are accounted for.

In general, the individual Functions are required to be OPERABLE in the MODES or other specified conditions when SCIVs and the SGT System are required.

The specific Applicable Safety Analyses, LCO, and Applicability discussions are listed below on a Function by Function basis.

1. Reactor Vessel Water Level—Low Low/Level 2 3

Low reactor pressure vessel (RPV) water level indicates that the capability to cool the fuel may be threatened. Should RPV water level decrease too far, fuel damage could result. An isolation of the secondary containment and actuation of the SGT System are initiated in order to minimize the potential of an offsite dose release. The Reactor Vessel Water Level—Low Low/Level 2 Function is one of the Functions assumed to be OPERABLE and capable of providing isolation and initiation signals. The isolation and initiation systems on Reactor Vessel Water Level—Low Low/Level 2 support actions to ensure that any offsite releases are within the limits calculated in the safety analysis. (Ref. 2)

G
of

differential pressure

Reactor Vessel Water Level—Low Low/Level 2 signals are initiated from Level transmitters that sense the difference between the pressure due to a constant column of water (reference leg) and the pressure due to the actual water level (variable leg) in the vessel. Four channels of Reactor Vessel Water Level—Low Low/Level 2 Function are available and are required to be OPERABLE to ensure that no single instrument failure can preclude the isolation function. 3

Reactor Protection System (RPS)

The Reactor Vessel Water Level—Low Low/Level 2 Allowable Value was chosen to be the same @ the High Pressure Coolant Injection/Reactor Core Isolation Looping (HPCI/RIC) Reactor Vessel Water Level—Low Low/Level 2 Allowable Value 3

(continued)

BASES

APPLICABLE
SAFETY ANALYSES,
LCO, and
APPLICABILITY

1. Reactor Vessel Water Level—Low (Low Level) ³
(continued)

1.1, "Reactor Protection System (RPS) Instrumentation" (LCO 3.3.6.1 and LCO 3.3.5.2), since this could indicate that the capability to cool the fuel is being threatened.

The Reactor Vessel Water Level—Low (Low Level) Function is required to be OPERABLE in MODES 1, 2, and 3 where considerable energy exists in the Reactor Coolant System (RCS); thus, there is a probability of pipe breaks resulting in significant releases of radioactive steam and gas. In MODES 4 and 5, the probability and consequences of these events are low due to the RCS pressure and temperature limitations of these MODES; thus, this Function is not required. In addition, the Function is also required to be OPERABLE during operations with a potential for draining the reactor vessel (OPDRVs) because the capability of isolating potential sources of leakage must be provided to ensure that offsite dose limits are not exceeded if core damage occurs. ¹

2. Drywell Pressure—High

High drywell pressure can indicate a break in the reactor coolant pressure boundary (RCPB). An isolation of the secondary containment and actuation of the SGT System are initiated in order to minimize the potential of an offsite dose release. The isolation on high drywell pressure supports actions to ensure that any offsite releases are within the limits calculated in the safety analysis. ²

However, the Drywell Pressure—High Function associated with isolation is not assumed in any FSAR accident or transient analyses. It is retained for the overall redundancy and diversity of the secondary containment isolation instrumentation as required by the NRC approved licensing basis. ¹

switches ¹

High drywell pressure signals are initiated from pressure transmitters that sense the pressure in the drywell. Four channels of Drywell Pressure—High Functions are available and are required to be OPERABLE to ensure that no single instrument failure can preclude performance of the isolation function.

The Allowable Value was chosen to be the same as the RPS Drywell Pressure—High Function Allowable Value ¹

(continued)

BASES

All changes are 1 unless otherwise indicated

APPLICABLE
SAFETY ANALYSES,
LCO, and
APPLICABILITY

2. Drywell Pressure—High (continued)

(LCO 3.3.6.1) since this is indicative of a loss of coolant accident (LOCA).

The Drywell Pressure—High Function is required to be OPERABLE in MODES 1, 2, and 3 where considerable energy exists in the RCS; thus, there is a probability of pipe breaks resulting in significant releases of radioactive steam and gas. This Function is not required in MODES 4 and 5 because the probability and consequences of these events are low due to the RCS pressure and temperature limitations of these MODES.

Exhaust Radiation—High

3. 4. Reactor Building and Refueling Floor Exhaust Radiation—High

or refuel floor radiation

or Refueling Floor Radiation—High

High secondary containment exhaust radiation is an indication of possible gross failure of the fuel cladding. The release may have originated from the primary containment due to a break in the RCPB or the refueling floor due to a fuel handling accident. When Exhaust Radiation—High is detected, secondary containment isolation and actuation of the SGT System are initiated to limit the release of fission products as assumed in the FSAR safety analyses (Ref. 4).

support actions to

associated

2 and 3

The Exhaust Radiation—High signals are initiated from radiation detectors that are located on the ventilation exhaust plumbing coming from the reactor building and the refueling floor zones, respectively. The signal from each detector is input to an individual monitor whose trip outputs are assigned to an isolation channel. Four channels of Reactor Building Exhaust Radiation—High Function and four channels of Refueling Floor Exhaust Radiation—High Function are available and are required to be OPERABLE to ensure that no single instrument failure can preclude the isolation function.

The Allowable Values are chosen to promptly detect gross failure of the fuel cladding.

Therefore, the channels must be declared inoperable if the associated reactor building ventilation exhaust duct is isolated.

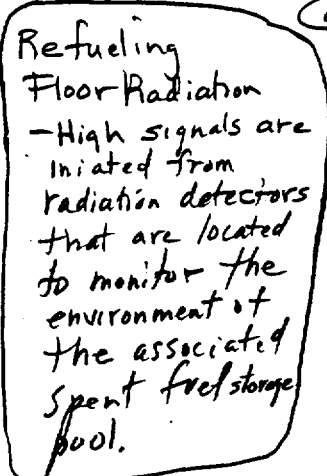
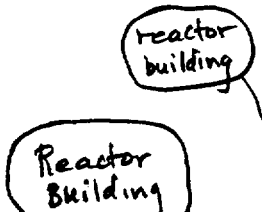

(continued)

BASES

Exhaust Radiation-High [3]

APPLICABLE
SAFETY ANALYSES,
LCO, and
APPLICABILITY

3. 4. Reactor Building and Refueling Floor Exhaust Radiation-High (continued)

in the RCS [2]

The Reactor Building and Refueling Floor Exhaust Radiation-High Functions are required to be OPERABLE in MODES 1, 2, and 3 where considerable energy exists; thus, there is a probability of pipe breaks resulting in significant releases of radioactive steam and gas. In MODES 4 and 5, the probability and consequences of these events are low due to the RCS pressure and temperature limitations of these MODES; thus, these Functions are not required. In addition, the Functions are also required to be OPERABLE during CORE ALTERATIONS, OPDRVs, and movement of irradiated fuel assemblies in the secondary containment, because the capability of detecting radiation releases due to fuel failures (due to fuel uncover or dropped fuel assemblies) must be provided to ensure that offsite dose limits are not exceeded.

5. Manual Initiation

The Manual Initiation push button channels introduce signals into the secondary containment isolation logic that are redundant to the automatic protective instrumentation channels and provide manual isolation capability. There is no specific FSAR safety analysis that takes credit for this Function. It is retained for the overall redundancy and diversity of the secondary containment isolation instrumentation as required by the NRC approved licensing basis. [3]

There are two push buttons for the logic, one manual initiation push button per trip system. There is no Allowable Value for this Function, since the channels are mechanically actuated based solely on the position of the push buttons.

Two channels of Manual Initiation Function are available and are required to be OPERABLE in MODES 1, 2, and 3, and during CORE ALTERATIONS, OPDRVs, and movement of irradiated fuel assemblies in the secondary containment. These are the MODES and other specified conditions in which the Secondary Containment Isolation automatic Functions are required to be OPERABLE.

BASES (continued)

ACTIONS

4
Reviewer's Note: Certain LCO Completion Times are based on approved topical reports. In order for a licensee to use the times, the licensee must justify the Completion Times as required by the staff Safety Evaluation Report (SER) for the topical report.

A Note has been provided to modify the ACTIONS related to secondary containment isolation instrumentation channels. Section 1.3, Completion Times, specifies that once a Condition has been entered, subsequent divisions, subsystems, components, or variables expressed in the Condition, discovered to be inoperable or not within limits, will not result in separate entry into the Condition. Section 1.3 also specifies that Required Actions of the Condition continue to apply for each additional failure, with Completion Times based on initial entry into the Condition. However, the Required Actions for inoperable secondary containment isolation instrumentation channels provide appropriate compensatory measures for separate inoperable channels. As such, a Note has been provided that allows separate Condition entry for each inoperable secondary containment isolation instrumentation channel.

2

, depending on the Function
(12 hours for those Functions that have channel components common to RPS instrumentation and 24 hours for those Functions that do not have channel components common to RPS instrumentation)

A.1

Because of the diversity of sensors available to provide isolation signals and the redundancy of the isolation design, an allowable out of service time of 12 hours ~~for Function 2, and~~ 24 hours ~~for Functions other than Function 2,~~ has been shown to be acceptable (Refs. ④ and ⑤) to permit restoration of any inoperable channel to OPERABLE status. This out of service time is only acceptable provided the associated Function is still maintaining isolation capability (refer to Required Action B.1 Bases). If the inoperable channel cannot be restored to OPERABLE status within the allowable out of service time, the channel must be placed in the tripped condition per Required Action A.1. Placing the inoperable channel in trip would conservatively compensate for the inoperability, restore capability to accommodate a single failure, and allow operation to continue. Alternately, if it is not desired to place the channel in trip (e.g., as in the case where placing the inoperable channel in trip would result in an isolation), Condition C must be entered and its Required Actions taken.

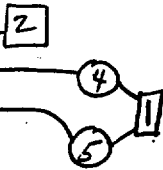

(continued)

BASES

ACTIONS
(continued)

B.1

Required Action B.1 is intended to ensure that appropriate actions are taken if multiple, inoperable, untripped channels within the same Function result in a complete loss of automatic isolation capability for the associated penetration flow path(s) or a complete loss of automatic initiation capability for the SGT System. A Function is considered to be maintaining secondary containment isolation capability when sufficient channels are OPERABLE or in trip, such that one trip system will generate a trip signal from the given Function on a valid signal. This ensures that one of the two SCIVs in the associated penetration flow path and the SGT system can be initiated on an isolation signal from the given Function. For the Functions with two one-out-of-two logic trip systems (Functions 1, 2, 3 and 4), this would require one trip system to have one channel OPERABLE or in trip. The Condition does not include the Manual Initiation Function (Function 5), since it is not assumed in any accident or transient analysis. Thus, a total loss of manual initiation capability for 24 hours (as allowed by Required Action A.1) is allowed.

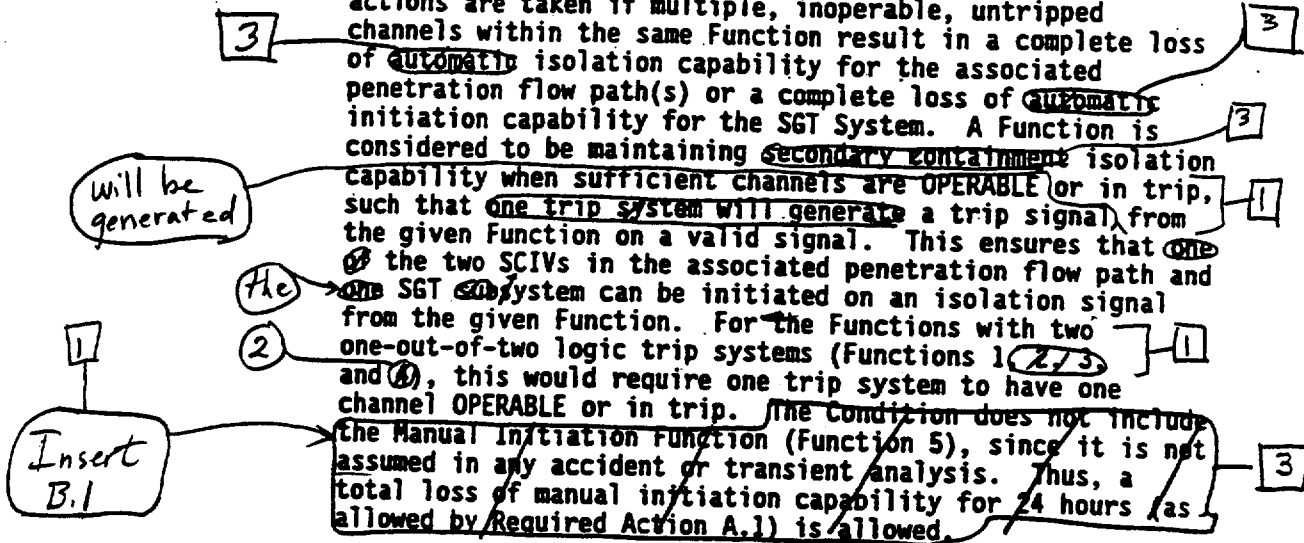

The Completion Time is intended to allow the operator time to evaluate and repair any discovered inoperabilities. The 1 hour Completion Time is acceptable because it minimizes risk while allowing time for restoration or tripping of channels.

C.1.1, C.1.2, C.2.1, and C.2.2

If any Required Action and associated Completion Time of Condition A or B are not met, the ability to isolate the secondary containment and start the SGT System cannot be ensured. Therefore, further actions must be performed to ensure the ability to maintain the secondary containment function. Isolating the associated zone (closing the ventilation supply and exhaust automatic isolation dampers) and starting the associated SGT subsystem (Required Actions C.1.1 and C.2.1) performs the intended function of the instrumentation and allows operation to continue.

Alternately, declaring the associated SCIVs or SGT subsystem(s) inoperable (Required Actions C.1.2 and C.2.2) is also acceptable since the Required Actions of the

associated penetration flow path(s)

The method used to place the SGT subsystem in operation must provide for automatically reinitiating the subsystem upon restoration of power following a loss of power to the SGT subsystem

(continued)

11

Insert B.1

For Functions 3 and 4, this would require each trip system to have one channel OPERABLE or in trip.

BASES

ACTIONS

C.1.1, C.1.2, C.2.1, and C.2.2 (continued)

respective LCOs (LCO 3.6.4.2 and LCO 3.6.4.3) provide appropriate actions for the inoperable components.

One hour is sufficient for plant operations personnel to establish required plant conditions or to declare the associated components inoperable without unnecessarily challenging plant systems.

SURVEILLANCE REQUIREMENTS

Reviewer's Note: Certain Frequencies are based on approved topical reports. In order for a licensee to use these Frequencies, the licensee must justify the Frequencies as required by the staff SER for the topical report.

As noted at the beginning of the SRs, the SRs for each Secondary Containment Isolation instrumentation Function are located in the SRs column of Table 3.3.6.2-1.

The Surveillances are modified by a Note to indicate that when a channel is placed in an inoperable status solely for performance of required Surveillances, entry into associated Conditions and Required Actions may be delayed for up to 6 hours provided the associated Function maintains ~~secondary~~ containment isolation capability. Upon completion of the Surveillance, or expiration of the 6 hour allowance, the channel must be returned to OPERABLE status or the applicable Condition entered and Required Actions taken. This Note is based on the reliability analysis (Refs. ④ ① and ⑤) assumption of the average time required to perform channel surveillance. That analysis demonstrated the 6 hour testing allowance does not significantly reduce the probability that the SCIVs will isolate the associated penetration flow paths and that the SGT System will initiate when necessary.

SR 3.3.6.2.1

Performance of the CHANNEL CHECK once every 12 hours ensures that a gross failure of instrumentation has not occurred. A CHANNEL CHECK is normally a comparison of the parameter indicated on one channel to a similar parameter on other

(continued)

BASES

SURVEILLANCE
REQUIREMENTS

SR 3.3.6.2.1 (continued)

channels. It is based on the assumption that instrument channels monitoring the same parameter should read approximately the same value. Significant deviations between the instrument channels could be an indication of excessive instrument drift in one of the channels or something even more serious. A CHANNEL CHECK will detect gross channel failure; thus, it is key to verifying the instrumentation continues to operate properly between each CHANNEL CALIBRATION.

Agreement criteria are determined by the plant staff based on a combination of the channel instrument uncertainties, including indication and readability. If a channel is outside the criteria, it may be an indication that the instrument has drifted outside its limit.

The Frequency is based on operating experience that demonstrates channel failure is rare. The CHANNEL CHECK supplements less formal, but more frequent, checks of channel status during normal operational use of the displays associated with channels required by the LCO.

SR 3.3.6.2.2

A CHANNEL FUNCTIONAL TEST is performed on each required channel to ensure that the entire channel will perform the intended function.

Any setpoint adjustment shall be consistent with the assumptions of the current plant specific setpoint methodology.

The Frequency of 92 days is based on the reliability analysis of References 4 and 5.

SR 3.3.6.2.3

Calibration of trip units provides a check of the actual trip setpoints. The channel must be declared inoperable if the trip setting is discovered to be less conservative than the Allowable Value specified in Table 3.3.6.2-1. If the trip setting is discovered to be less conservative than

(continued)

BASES

**SURVEILLANCE
REQUIREMENTS**

SR 3.3.6.2.3 (continued)

accounted for in the appropriate setpoint methodology, but is not beyond the Allowable Value, performance is still within the requirements of the plant safety analysis. Under these conditions, the setpoint must be readjusted to be equal to or more conservative than accounted for in the appropriate setpoint methodology.

The Frequency of 92 days is based on the reliability analysis of References ④ and ⑤.

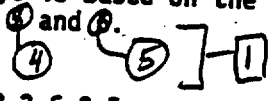

SR 3.3.6.2.4 and SR 3.3.6.2.5

A CHANNEL CALIBRATION is a complete check of the instrument loop and the sensor. This test verifies the channel responds to the measured parameter within the necessary range and accuracy. CHANNEL CALIBRATION leaves the channel adjusted to account for instrument drifts between successive calibrations consistent with the plant specific setpoint methodology.

The Frequencies of SR 3.3.6.2.4 and SR 3.3.6.2.5 are based on the assumption of a 92 day and an ~~an~~ 24 month calibration interval, respectively, in the determination of the magnitude of equipment drift in the setpoint analysis.

24

3

SR 3.3.6.2.6

The LOGIC SYSTEM FUNCTIONAL TEST demonstrates the OPERABILITY of the required isolation logic for a specific channel. The system functional testing performed on SCIVs and the SGT System in LCO 3.6.4.2 and LCO 3.6.4.3, respectively, overlaps this Surveillance to provide complete testing of the assumed safety function.

24

3

The 24 month Frequency is based on the need to perform this Surveillance under the conditions that apply during a plant outage and the potential for an unplanned transient if the Surveillance were performed with the reactor at power.

(continued)

BASES

SURVEILLANCE
REQUIREMENTS

SR 3.3.6.2.6 (continued)

Operating experience has shown that these components usually pass the Surveillance when performed at the 18 month Frequency.

(24) — (3)

SR 3.3.6.2.7

This SR ensures that the individual channel response times are less than or equal to the maximum value assumed in the accident analysis. Testing is performed only on channels where the assumed response time does not correspond to the diesel generator (DG) start time. For channels assumed to respond within the DG start time, sufficient margin exists in the [10] second start time when compared to the typical channel response time (milliseconds) so as to assure adequate response without a specific measurement test. The instrument response times must be added to the SCIV closure times to obtain the ISOLATION SYSTEM RESPONSE TIME. ISOLATION SYSTEM RESPONSE TIME acceptance criteria are included in Reference 7.

(3)

A Note to the Surveillance states that the radiation detectors may be excluded from ISOLATION SYSTEM RESPONSE TIME testing. This Note is necessary because of the difficulty of generating an appropriate detector input signal and because the principles of detector operation virtually ensure an instantaneous response time. Response time for radiation detector channels shall be measured from detector output or the input of the first electronic component in the channel.

ISOLATION SYSTEM RESPONSE TIME tests are conducted on an 18 month STAGGERED TEST BASIS. The 18 month Frequency is consistent with the typical industry refueling cycle and is based on plant operating experience, which shows that random failures of instrumentation components causing serious response time degradation, but not channel failure, are infrequent occurrences.

REFERENCES

1. FSAR, Section ~~6.2.3~~ (6.2.3) [5]
2. FSAR, ~~Chapter 15~~ (Chapter 15) Section 15.6.5 [5]

(continued)

Secondary Containment Isolation Instrumentation
B 3.3.6.2

BASES

REFERENCES
(continued)

- 3. FSAR, Section ~~[15.1.7.4]~~ 15.7.2 [5]
- 4. FSAR, Sections ~~[15.1.39 and 15.1.41]~~ [1]
- 4. NEDC-31677P-A, "Technical Specification Improvement Analysis for BWR Isolation Actuation Instrumentation," July 1990.
- 5. NEDC-30851P-A Supplement 2, "Technical Specifications Improvement Analysis for BWR Isolation Instrumentation Common to RPS and ECCS Instrumentation," March 1989.
- 7. FSAR, Section ~~[7.3]~~ [3]

JUSTIFICATION FOR DEVIATIONS FROM NUREG-1433, REVISION 1
ITS BASES: 3.3.6.2 - SECONDARY CONTAINMENT ISOLATION INSTRUMENTATION

1. Changes have been made (additions, deletions, and/or changes to the NUREG) to reflect the plant specific methodology, nomenclature, number, reference, system description, analysis description, or licensing basis description.
2. Editorial change made for enhanced clarity or to be consistent with similar statements in other places in the Bases.
3. Changes have been made to reflect those changes made to the Specification or to be consistent with the Specification. The following requirements have been renumbered, where applicable, to reflect the changes.
4. This Reviewer's Note has been deleted. This information is for the NRC reviewer to be keyed in to what is needed to meet this requirement. This is not meant to be retained in the final version of the plant specific submittal.
5. The brackets have been removed and the proper plant specific information/value has been provided.

All changes are 2 unless noted otherwise

Relief Valve

L/S Instrumentation
B 3.3.6.3

1

B 3.3 INSTRUMENTATION

B 3.3.6.3 Low/Low Set (L/S) Instrumentation

BASES

low set portion of relief valve

BACKGROUND

The L/S logic and instrumentation is designed to mitigate the effects of postulated thrust loads on the safety relief valve S/RV discharge lines by preventing subsequent actuations with an elevated water leg in the S/RV discharge line. It also mitigates the effects of postulated pressure loads on the torus shell or suppression pool by preventing multiple actuations in rapid succession of the S/RVs relief valve subsequent to their initial actuation.

The low set function of relief valve instrumentation is contained within the control logic of the two relief valves that are set to initiate first on an overpressure event. The relief valve instrumentation, as a whole, is designed to mitigate the effects of overpressurization transients via the relief mode of five relief valves.

~~Upon initiation, the LLS logic will assign preset opening and closing setpoints to four preselected S/RVs. These setpoints are selected such that the LLS S/RVs will stay open longer; thus, releasing more steam (energy) to the suppression pool, and hence more energy (and time) will be required for repressurization and subsequent S/RV openings. The LLS logic increases the time between (or prevents) subsequent actuations to allow the high water leg created from the initial S/RV opening to return to (or fall below) its normal water level; thus, reducing thrust loads from subsequent actuations to within their design limits. In addition, the LLS is designed to limit S/RV subsequent actuations to one valve, so torus loads will also be reduced.~~

relief valve

Insert
BK6D-1

The LLS instrumentation logic is arranged in two divisions with Logic channels A and C in one division and Logic channels B and D in the other division (Ref. 1). Each LLS logic channel (e.g., Logic A channel) controls one LLS valve. The LLS logic channels will not actuate their associated LLS valves at their LLS setpoints until the arming portion of the associated LLS logic is satisfied. Arming occurs when any one of the 11 S/RVs opens as indicated by a signal from one of the redundant pressure switches located on its tailpipe coincident with a high reactor pressure signal. Each division receives tailpipe arming signals from dedicated tailpipe pressure switches on each of the 11 S/RVs, six in Logic C and five in the other LLS logic (e.g., Logic A). Each LLS logic (e.g., Logic A) receives the reactor pressure arming signal from a different reactor pressure transmitter and trip unit. These arming signals seal in until reset. The arming signal from one

(continued)

2

Insert BKGD-1

The relief valve instrumentation logic consists of separate channels for each of the five relief valves with each channel controlling one associated relief valve. Each channel contains a high pressure (PS_H) switch and a low pressure (PS_L) switch. The pressure switches sense reactor pressure from the upstream side of the relief valve to open the associated relief valve on a sensed high reactor pressure and close the valve following a reduction in reactor pressure. Actuation of the associated relief valve is accomplished via closure of the PS_H on a sensed high reactor pressure, which energizes the relief valve solenoid to open the valve. The PS_L closes to seal in the actuation signal and opens when reactor pressure has decreased below the low pressure setpoint of the switch to de-energize the solenoid and allow the relief valve to close.

The relief valve high pressure setpoints are set such that two of the five relief valves (i.e., the Low Set Relief Valves) will actuate at a pressure that is approximately twenty pounds lower than the remaining three relief valves (i.e., the Relief Valves). The lower pressure settings are intended to reduce the frequency of multiple relief discharges.

Two Low Set Relief Valve Reactuation Time Delay channels are included in the associated control logic for the two relief valves designated to open at the lower reactor pressure (i.e., the Low Set Relief Valves). Each channel consists of a time delay dropout relay and its associated contacts. The channels are arranged in a two-out-of-two logic arrangement for each low set relief valve. The Low Set Relief Valve Reactuation Time Delay Function ensures a time delay of approximately 10 seconds occurs between the closure of the associated relief valve and any subsequent opening of the valve by preventing the reopening of the valve. In this fashion, the low set portion of relief valve instrumentation

Relief Valve

1

LLS Instrumentation
B 3.3.6.3

BASES

BACKGROUND
(continued)

Logic is sent to the other logic within the same division and performs the same function as the tailpipe arming signal (i.e., Logic A will arm if it has received a high reactor pressure signal and Logic C has armed).

After arming, opening of each LLS valve is by a two-out-of-two logic from one reactor pressure transmitter and two trip units set to trip at the required LLS opening setpoint. The LLS valve recloses when reactor pressure has decreased to the reclose setpoint of one of the two trip units used to open the valve (one-out-of-two logic).

This logic arrangement prevents single instrument failures from precluding the LLS S/RV function. The channels include electronic equipment (e.g., trip units) that compares measured input signals with pre-established setpoints. When the setpoint is exceeded, the channel output relay actuates, which then outputs a LLS initiation signal to the initiation logic.

2

APPLICABLE SAFETY ANALYSES

relief valve 1 low set

The LLS instrumentation and Logic function ensures that the containment loads remain within the primary containment design basis (Ref. (2)).

1 and Insert ASA

The LLS instrumentation satisfies Criterion 3 of the NRC Policy Statement.

16 CFR 50.36 (c)(7)(ii)

2

2

LCO

The LCO requires OPERABILITY of sufficient LLS instrumentation channels to ensure successfully accomplishing the LLS function assuming any single instrumentation channel failure within the LLS logic.

Therefore, the OPERABILITY of the LLS instrumentation is dependent on the OPERABILITY of the instrumentation channel Function specified in Table 3.3.6.3-1. Each Function must have a required number of OPERABLE channels, with their setpoints within the specified Allowable Value. A channel is inoperable if its actual trip setpoint is not within its required Allowable Value. The actual setpoint is calibrated consistent with applicable setpoint methodology assumptions.

Allowable Values are specified for each LLS actuation Function in Table 3.3.6.3-1. Nominal trip setpoints are

relief valve

1

relief valve

1

(continued)

2

Insert ASA

The opening setpoints of the relief valves also ensure that the transient analyses of Reference 3 can be met.

BASES

LCO
(continued)

specified in the setpoint calculations. The nominal setpoints are selected to ensure the setpoints do not exceed the Allowable Value between CHANNEL CALIBRATIONS. Operation with a trip setpoint less conservative than the nominal trip setpoint, but within its Allowable Value, is acceptable. Trip setpoints are those predetermined values of output at which an action should take place. The setpoints are compared to the actual process parameter (e.g., reactor vessel ~~water level~~), and when the measured output value of the process parameter exceeds the setpoint, the associated device (e.g., trip unit) changes state. The analytic limits are derived from the limiting values of the process parameters obtained from the safety analysis.

pressure

Insert LCO-1

The Allowable Values are derived from the analytic limits, corrected for calibration, process, and some of the instrument errors. The trip setpoints are then determined accounting for the remaining instrument errors (e.g., drift). The trip setpoints derived in this manner provide adequate protection because instrumentation uncertainties, process effects, calibration tolerances, instrument drift, and severe environment errors (for channels that must function in harsh environments as defined by 10 CFR 50.49) are accounted for.

Insert LLO-2

The Tailpipe Pressure Switch Allowable Value is based on ensuring that a proper arming signal is sent to the LLS logic. That is, the pressure switch is initiated only when an S/RV has opened.

The Reactor Steam Dome Pressure-High was chosen to be the same as the Reactor Protection System (RPS) Reactor Steam Dome Pressure Allowable Value (LCO 3.3.1.1) because it would be expected that LLS would be needed for pressurization events. Providing LLS after a scram has been initiated would prevent false initiations of LLS at 100% power. The LLS valve open and close Allowable Values are based on the safety analysis performed in Reference 2, 3, 1, 2, and 3.

relief valve

relief valve

APPLICABILITY

The LLS instrumentation is required to be OPERABLE in MODES 1, 2, and 3 since considerable energy is in the nuclear system and the ~~S/RVs~~ may be needed to provide pressure relief. If the ~~S/RVs~~ are needed, then the LLS function is required to ensure that the primary containment design basis is maintained. In MODES 4 and 5, the reactor pressure is low enough that the overpressure limit cannot be

relief valves 3

relief valve

(continued)

2

Insert LCO-1

The trip setpoints are determined from the analytic limits, corrected for defined process, calibration, and instrument errors. The Allowable Values are then determined, based on the trip setpoint values, by accounting for the calibration based errors. These calibration based errors are limited to reference accuracy, instrument drift, errors associated with measurement and test equipment, and calibration tolerance of loop components. The trip setpoints and Allowable Values determined in this manner provide adequate protection because instrument uncertainties, process effects, calibration tolerances, instrument drift, and severe environment errors (for channels that must function in harsh environments as defined by 10 CFR 50.49) are accounted for and appropriately applied for the instrumentation.

2

Insert LCO-2

The Low Set Relief Valve Reactuation Time Delay is based on preventing unacceptable thrust loads on relief valve discharge piping due to relief valve openings with elevated water leg conditions. The time delay setpoint was chosen to ensure the two low set relief valves will remain closed following their initial opening, until normal water level in the discharge line is restored and is based on the calculated worst case elevated water leg duration.

All changes [2] unless noted otherwise

Relief Valve

4

LLS Instrumentation
B 3.3.6.3

BASES

1.e or 2.a channel; as applicable

APPLICABILITY
(continued)

approached by assumed operational transients or accidents. Thus, LLS instrumentation and associated pressure relief is not required.

1 relief valve

ACTIONS

Reviewer's Note: Certain LEO Completion Times are based on approved topical reports. In order for a licensee to use the times, the licensee must justify the Completion Times as required by the staff Safety Evaluation Report (SER) for the topical report.

A.1

relief valve

4

or low set time delay

The failure of any reactor steam dome pressure instrument channel to provide the arming, S/RV opening and closing pressure setpoints for an individual LLS valve does not affect the ability of the other LLS/S/RVs to perform their LLS function. A LLS valve is OPERABLE if the associated logic, (e.g., Logic R), has one Function 2 channel, two Function 3 channels, and three Function 3 channels OPERABLE.

relief
relief valves

1

relief or low set

relief

and for low set relief valves, two Function 1.b channels

Therefore, 24 hours is provided to restore the inoperable channel(s) to OPERABLE status (Required Action A.1). If the inoperable channel(s) cannot be restored to OPERABLE status within the allowable out of service time, Condition B must be entered and its Required Action taken. The Required Actions do not allow placing the channel in trip since this action could result in an instrumented LLS valve actuation.

14 days

B

The 24 hour Completion Time is considered appropriate because of the redundancy in the design (four LLS valves are provided and any one LLS valve can perform the LLS function) and the very low probability of multiple LLS instrumentation channel failures, which render the remaining LLS S/RVs inoperable, occurring together with an event requiring the LLS function during the 24 hour Completion Time. The 24 hour Completion Time is also based on the reliability analysis of Reference 3.

five relief

14 day

four relief

relief valves

relief or low set

14 day

relief

two low set relief valves are provided and one low set relief valve can perform the low set function

B.1

Although the LLS circuitry is designed so that operation of a single tailpipe pressure switch will result in arming both LLS logics in its associated division, each tailpipe pressure switch provides a direct input to only one LLS

1

(continued)

The 14 day Completion Time to restore inoperable channels to OPERABLE status is based on the relief capability of the remaining relief valves, the low probability of an event requiring relief valve actuation and a reasonable time to complete the Required Action.

BASES

ACTIONS

B.1 (continued)

logic (e.g., Logic A). Since each LLS logic normally receives at least five S/RV pressure switch inputs (and also receives the other S/RV signals from the other logic in the same division by an arming signal), the LLS logic and instrumentation remains capable of performing its safety function if any S/RV tailpipe pressure switch instrument channel becomes inoperable. Therefore, it is acceptable for plant operation to continue with only one tailpipe pressure switch OPERABLE on each S/RV. However, this is only acceptable provided each LLS valve is OPERABLE. (Refer to Required Action A.1 and D.1 Bases).

Required Action B.1 requires restoration of the tailpipe pressure switches to OPERABLE status prior to entering MODE 2 or 3 from MODE 4 to ensure that all switches are OPERABLE at the beginning of a reactor startup (this is because the switches are not accessible during plant operation). The Required Actions do not allow placing the channel in trip since this action could result in a LLS valve actuation. As noted, LCO 3.0.4 is not applicable, thus allowing entry into MODE 1 from MODE 2 with inoperable channels. This allowance is needed since the channels only have to be repaired prior to entering MODE 2 from MODE 3 or MODE 4. Yet, LCO 3.0.4 would preclude entry into MODE 1 from MODE 2 since the Required Action does not allow unlimited operations.

C.1

A failure of two pressure switch channels associated with one S/RV tailpipe could result in the loss of the LLS function (i.e., multiple actuations of the S/RV would go undetected by the LLS logic). However, the S/RVs are organized in groups and, during an event, groups of S/RVs initially open (setpoints are at same settings for a total of 11 S/RVs in three groups). Therefore, it would be very unlikely that a single S/RV would be required to arm all the LLS logic. Therefore, it is acceptable to allow 14 days to restore one pressure switch of the associated S/RV to OPERABLE status (Required Action C.1). However, this allowable out of service time is only acceptable provided each LLS is OPERABLE (Refer to Required Action A.1 and D.1 Bases). If one inoperable tailpipe pressure switch cannot

(continued)

Relief Valve

LLS Instrumentation
B 3.3.6.3

1

BASES

ACTIONS

C.1 (continued)

be restored to OPERABLE status within the allowable out of service time. Condition D must be entered and its Required Action taken. The Required Actions do not allow placing the channels in trip since this action could result in a LLS valve actuation.

A Note has been provided in the Condition to modify the Required Actions and Completion Times conventions related to LLS Function 3 channels. Section 1.3, Completion Times, specifies that once a Condition has been entered, subsequent divisions, subsystems, components, or variables expressed in the Condition, discovered to be inoperable or not within limits, will not result in separate entry into the Condition. Section 1.3 also specifies that Required Actions of the Condition continue to apply for each additional failure, with Completion Times based on initial entry into the Condition. However, the Required Actions for inoperable LLS Function 3 channels provide appropriate compensatory measures for separate inoperable Condition entry for each S/RV with inoperable tailpipe pressure switches.

13

the

15

plant must be brought to a MODE in which the LCD does not apply. To achieve this status, the plant must be brought to MODE 3 within 12 hours and to MODE 4 within 36 hours. The allowed Completion Times are reasonable, based on operating experience, to reach required plant conditions from full power conditions in an orderly manner and without challenging plant systems.

If ~~any~~ Required Action and associated Completion Time of Condition A, B, or C are not met, or two or more LLS valves are inoperable due to inoperable channels, the LLS valves may be incapable of performing their intended function. Therefore, the associated LLS valve must be declared inoperable immediately. A LLS valve is OPERABLE if the associated logic (e.g., Logic A) has one Function 1 channel, two Function 2 channels, and three Function 3 channels.

relief

relief or low set

SURVEILLANCE REQUIREMENTS

Reviewer's Note: Certain Frequencies are based on approved topical reports. In order for a licensee to use the Frequencies, the licensee must justify the Frequencies as required by the staff SER for the topical report.

4

As noted at the beginning of the SRs, the SRs for each LLS instrumentation Function are located in the SRs column of Table 3.3.6.3-1.

(continued)

BASES

SURVEILLANCE
REQUIREMENTS
(continued)

The Surveillances are modified by a Note to indicate that when a channel is placed in an inoperable status solely for performance of required Surveillances, entry into associated Conditions and Required Actions may be delayed for up to 6 hours provided the associated Function maintains LLS initiation capability. Upon completion of the Surveillance, or expiration of the 6 hour allowance, the channel must be returned to OPERABLE status or the applicable Condition entered and Required Actions taken. This Note is based on the reliability analysis (Ref. 3) assumption of the average time required to perform channel surveillance. That analysis demonstrated that the 6 hour testing allowance does not significantly reduce the probability that the LLS valves will initiate when necessary.

SR 3.3.6.3.1

Performance of the CHANNEL CHECK once every 12 hours ensures that a gross failure of instrumentation has not occurred. A CHANNEL CHECK is normally a comparison of the parameter indicated on one channel to a similar parameter on another channel. It is based on the assumption that instrument channels monitoring the same parameter should read approximately the same value. Significant deviations between the instrument channels could be an indication of excessive instrument drift in one of the channels or something even more serious. A CHANNEL CHECK will detect gross channel failure, thus, it is key to verifying the instrumentation continues to operate properly between each CHANNEL CALIBRATION.

Agreement criteria are determined by the plant staff based on a combination of the channel instrument uncertainties, including indication and readability. If a channel is outside the criteria, it may be an indication that the instrument has drifted outside its limit.

The Frequency is based upon operating experience that demonstrates channel failure is rare. The CHANNEL CHECK supplements less formal, but more frequent, checks of channels during normal operational use of the displays associated with channels required by the LCO.

(continued)

Relief Valve

LKS Instrumentation
B 3.3.6.3

1

BASES

SURVEILLANCE
REQUIREMENTS
(continued)

~~SR 3.3.6.3.2, SR 3.3.6.3.3, and SR 3.3.6.3.4~~

~~A CHANNEL FUNCTIONAL TEST is performed on each required channel to ensure that the entire channel will perform the intended function. Any setpoint adjustment shall be consistent with the assumptions of the current plant specific setpoint methodology.~~

~~The 92 day Frequency is based on the reliability analysis of Reference 3.~~

~~A portion of the S/RV tailpipe pressure switch instrument channels are located inside the primary containment. The Note for SR 3.3.6.3.3, "Only required to be performed prior to entering MODE 2 during each scheduled outage > 72 hours when entry is made into primary containment," is based on the location of these instruments, ALARA considerations, and compatibility with the Completion Time of the associated Required Action (Required Action B.1).~~

1

~~SR 3.3.6.3.5~~

~~The calibration of trip units provides a check of the actual trip setpoints. The channel must be declared inoperable if the trip setting is discovered to be less conservative than the Allowable Value. If the trip setting is discovered to be less conservative than accounted for in the appropriate setpoint methodology, but is not beyond the Allowable Value, the channel performance is still within the requirements of the plant safety analysis. Under these conditions, the setpoint must be readjusted to be equal to or more conservative than the setting accounted for in the appropriate setpoint methodology. The Frequency of every 92 days for SR 3.3.6.3.5 is based on the reliability analysis of Reference 3.~~

1

~~SR 3.3.6.3.6~~



~~CHANNEL CALIBRATION is a complete check of the instrument loop and sensor. This test verifies the channel responds to the measured parameter within the necessary range and accuracy. CHANNEL CALIBRATION leaves the channel adjusted to account for instrument drifts between successive~~

(continued)

Relief Valve

LS Instrumentation
B 3.3.6.3

1

BASES

SURVEILLANCE REQUIREMENTS

SR 3.3.6.3.1 (continued)

calibrations consistent with the plant specific setpoint methodology.

The Frequency of once every 18 months for SR 3.3.6.3.1 is based on the assumption of an 18 month calibration interval in the determination of the magnitude of equipment drift in the setpoint analysis.

24

SR 3.3.6.3.2

The LOGIC SYSTEM FUNCTIONAL TEST demonstrates the OPERABILITY of the required actuation logic for a specified channel. The system functional testing performed in LCO 3.4.3, "Safety/Relief Valves (S/RVs)" and LCO 3.6.1.8, "Low-Low Set (LLS) Safety/Relief Valves (S/RVs)," overlaps this test to provide complete testing of the assumed safety function.

and

The Frequency of once every 18 months for SR 3.3.6.3.2 is based on the need to perform this Surveillance under the conditions that apply during a plant outage and the potential for an unplanned transient if the Surveillance were performed with the reactor at power. Operating experience has shown these components usually pass the Surveillance when performed at the 18 month Frequency.

REFERENCES

1. FSAR, Figure 5.2.2
2. FSAR, Section 6.2.1.3.4
3. GENE-770-06-1, "Bases for Changes to Surveillance Test Intervals and Allowed Out-of-Service Times for Selected Instrumentation Technical Specifications," February 1991.

3. UFSAR, Chapter 15.

JUSTIFICATION FOR DEVIATIONS FROM NUREG-1433, REVISION 1
ITS BASES: 3.3.6.3 - RELIEF VALVE INSTRUMENTATION

1. Changes have been made to reflect those changes made to the Specification. Subsequent requirements have been renumbered, where applicable, to reflect the changes.
2. Changes have been made (additions, deletions, and/or changes to the NUREG) to reflect the plant specific nomenclature, number, reference, system description, analysis description, or licensing basis description.
3. Changes have been made to be consistent with other places in the Bases.
4. This Reviewer's Note has been deleted. This information is for the NRC reviewer to be keyed in to what is needed to meet this requirement. This is not meant to be retained in the final version of the plant specific submittal.
5. The brackets have been removed and the proper plant specific values/information included.

All changes are [1] unless otherwise indicated

B 3.3 INSTRUMENTATION

B 3.3.7.1 ~~MC~~ Control Room Instrumentation

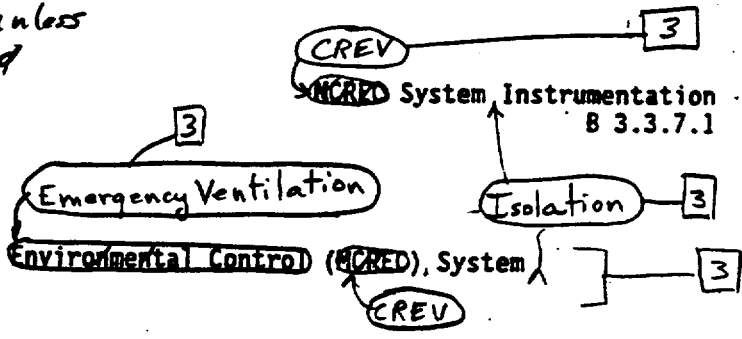

BASES

BACKGROUND

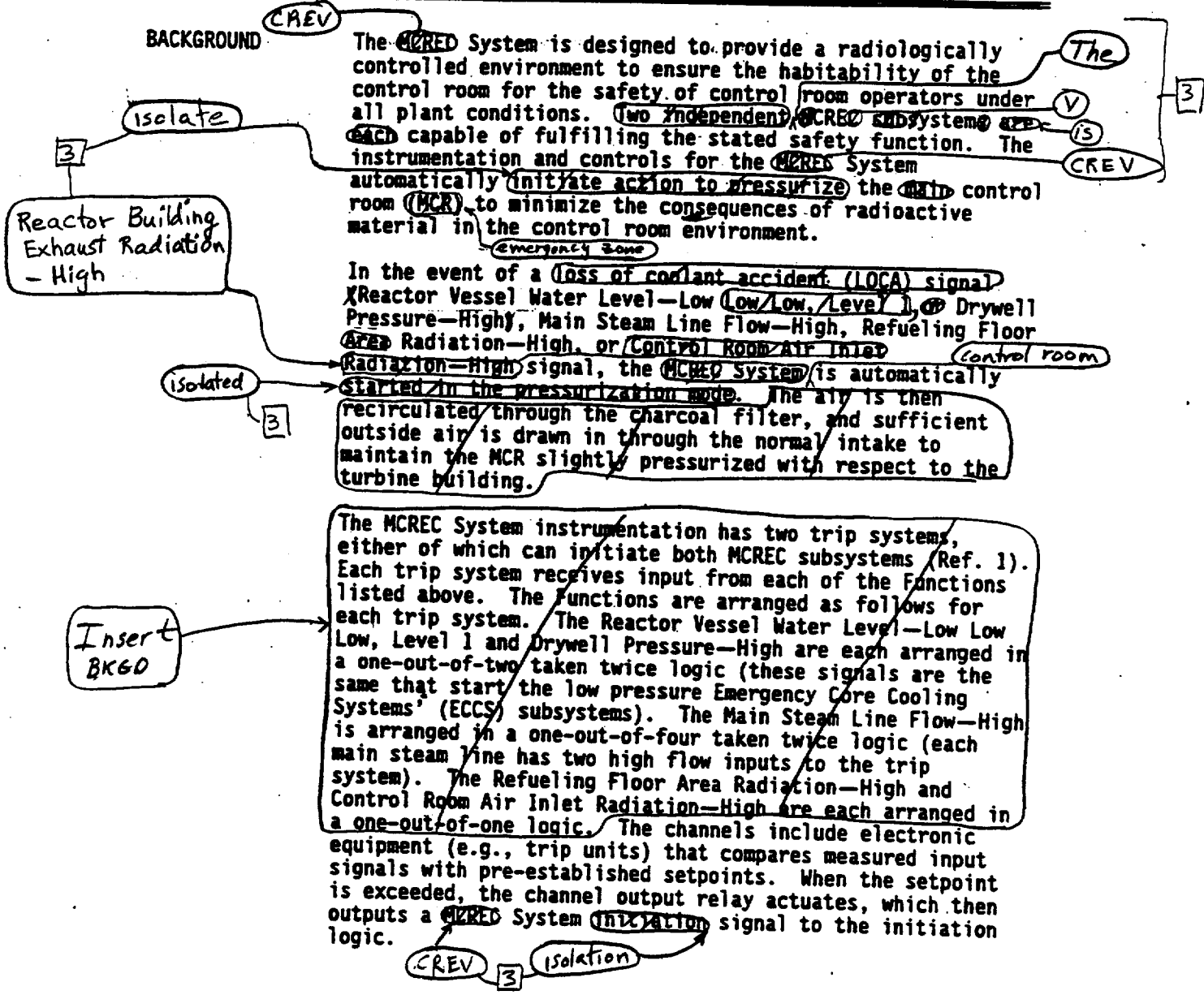

The ~~MC~~RED System is designed to provide a radiologically controlled environment to ensure the habitability of the control room for the safety of control room operators under all plant conditions. ~~Two independent MCRED subsystems are each~~ capable of fulfilling the stated safety function. The instrumentation and controls for the ~~MC~~RED System automatically ~~initiate action to pressurize~~ the ~~MC~~ control room (MCR) to minimize the consequences of radioactive material in the control room environment.

In the event of a ~~loss of coolant accident (LOCA) signal~~ (Reactor Vessel Water Level—Low ~~Low/Low/Level 1~~), ~~Drywell Pressure—High~~, Main Steam Line Flow—High, Refueling Floor ~~Area Radiation—High~~, or ~~Control Room Air Inlet Radiation—High~~ signal, the ~~MC~~RED System is automatically started in the pressurization mode. The air is then recirculated through the charcoal filter, and sufficient outside air is drawn in through the normal intake to maintain the MCR slightly pressurized with respect to the turbine building.

The MCRED System instrumentation has two trip systems, either of which can initiate both MCRED subsystems (Ref. 1). Each trip system receives input from each of the Functions listed above. The Functions are arranged as follows for each trip system. The Reactor Vessel Water Level—Low Low, Level 1 and Drywell Pressure—High are each arranged in a one-out-of-two taken twice logic (these signals are the same that start the low pressure Emergency Core Cooling Systems' (ECCS) subsystems). The Main Steam Line Flow—High is arranged in a one-out-of-four taken twice logic (each main steam line has two high flow inputs to the trip system). The Refueling Floor Area Radiation—High and Control Room Air Inlet Radiation—High are each arranged in a one-out-of-one logic. The channels include electronic equipment (e.g., trip units) that compares measured input signals with pre-established setpoints. When the setpoint is exceeded, the channel output relay actuates, which then outputs a ~~MC~~RED System ~~initiation~~ signal to the initiation logic.

(continued)

□
INSERT BKGD

For both the Reactor Vessel Water Level-Low and Drywell Pressure-High Functions, the CREV System isolation instrumentation logic receives input from four channels. The output from these channels are arranged into two one-out-of-two trip system logics. Both trip systems must trip to isolate the control room. The Main Steam Line Flow-High Function uses 16 channels, four for each main steam line. One channel from each main steam line inputs to one of the four trip strings. Two trip strings make up each trip system and both trip systems must trip to isolate the control room. Each trip string has four inputs (one per MSL), any one of which will trip the trip string. The trip strings are arranged in a one-out-of-two taken twice logic. This is effectively a one-out-of-eight taken twice logic arrangement to initiate isolation. For both Reactor Building Ventilation Exhaust Radiation-High and Refueling Floor Radiation-High Functions, the CREV System isolation logic receives input from four channels. Two channels associated with the Reactor Building Ventilation Exhaust Radiation-High Function are located in each reactor building exhaust duct while two channels associated with the Refueling Floor Radiation-High Function are located where they can monitor the environment of each of the unit spent fuel pools. The outputs of the channels associated with Unit 1 are provided to one trip system while the outputs of the channels associated with Unit 2 are provided to the other trip system. The outputs from these channels are arranged into two one-out-of-two trip system logics for each Function. A trip of any trip system will initiate the control room isolation function. Any Reactor Building Exhaust Radiation-High or Refueling Floor Radiation-High channel will initiate the control room isolation function. All Refueling Floor Radiation-High and Reactor Building Ventilation Exhaust Radiation-High Function channels are common to both Unit 1 and 2.

All changes are [1] unless otherwise indicated



BASES (continued)

APPLICABLE SAFETY ANALYSES, LCO, and APPLICABILITY

The ability of the MCRE System to maintain the habitability of the ~~RA~~ is explicitly assumed for certain accidents as discussed in the FSAR safety analyses (Refs. 1, 2, and 3). MCRE System operation ensures that the radiation exposure of control room personnel, through the duration of any one of the postulated accidents, does not exceed the limits set by GDC 19 of 10 CFR 50, Appendix A.

isolation and

MCRE System instrumentation satisfies Criterion 3 of the NRC Policy Statement.

The OPERABILITY of the MCRE System instrumentation is dependent upon the OPERABILITY of the individual instrumentation channel Functions specified in Table 3.3.7.1-1. Each Function must have a required number of OPERABLE channels, with their setpoints within the specified Allowable Values, where appropriate. A channel is inoperable if its actual trip setpoint is not within its required Allowable Value. The actual setpoint is calibrated consistent with applicable setpoint methodology assumptions.

Allowable Values are specified for each MCRE System Function specified in the Table. Nominal trip setpoints are specified in the setpoint calculations. The nominal setpoints are selected to ensure that the setpoints do not exceed the Allowable Value between successive CHANNEL CALIBRATIONS. Operation with a trip setpoint less conservative than the nominal trip setpoint, but within its Allowable Value, is acceptable. Trip setpoints are those predetermined values of output at which an action should take place. The setpoints are compared to the actual process parameter (e.g., reactor vessel water level), and when the measured output value of the process parameter exceeds the setpoint, the associated device (e.g., trip unit) changes state. The analytic limits are derived from the limiting values of the process parameters obtained from the safety analysis. The Allowable Values are derived from the analytic limits, corrected for calibration, process, and some of the instrument errors. The trip setpoints are then determined accounting for the remaining instrument errors (e.g., drift). The trip setpoints derived in this manner provide adequate protection because instrumentation uncertainties, process effects, calibration tolerances, instrument drift, and severe environment errors (for channels that must function in harsh environments as defined by 10 CFR 50.49) are accounted for.

Insert ASA

(continued)

11

Insert ASA

The trip setpoints are determined from the analytic limits, corrected for defined process, calibration, and instrument errors. The Allowable Values are then determined, based on the trip setpoint values, by accounting for the calibration based errors. These calibration based errors are limited to reference accuracy, instrument drift, errors associated with measurement and test equipment, and calibration tolerance of loop components. The trip setpoints and Allowable Values determined in this manner provide adequate protection because instrument uncertainties, process effects, calibration tolerances, instrument drift, and severe environment errors (for channels that must function in harsh environments as defined by 10 CFR 50.49) are accounted for and appropriately applied for the instrumentation.

All changes are II
 unless otherwise
 indicated

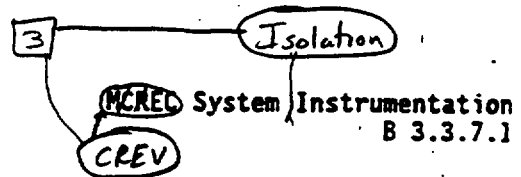

BASES

APPLICABLE
 SAFETY ANALYSES,
 LCO, and
 APPLICABILITY
 (continued)

The specific Applicable Safety Analyses, LCO, and Applicability discussions are listed below on a Function by Function basis.

1. Reactor Vessel Water Level—Low (Low Low Level) 3

Low reactor pressure vessel (RPV) water level indicates that the capability of cooling the fuel may be threatened. A low reactor vessel water level could indicate a LOCA and will automatically initiate the ~~MCREL System~~, since this could be a precursor to a potential radiation release and subsequent radiation exposure to control room personnel.

3
 Isolation of
 the control
 room emergency
 zone

Reactor Vessel Water Level—Low (Low Low Level) signals are initiated from four (level) transmitters that sense the difference between the pressure due to a constant column of water (reference leg) and the pressure due to the actual water level (variable leg) in the vessel. Four channels of Reactor Vessel Water Level—Low (Low Low Level) Function are available (two channels per trip system) and are required to be OPERABLE to ensure that a single instrument failure can preclude ~~MCREL System~~ initiation. The Reactor Vessel Water Level—Low (Low Low Level) Allowable Value was chosen to be the same as the ~~CCRS~~ Reactor Vessel Water Level—Low (Low Low Level) Allowable Value (LCO 3.3.8.1, ~~SEPS~~ Instrumentation").

differential
 pressure

Control
 room emergency
 zone
 isolation

Reactor Protection
 System (RPS)

Reactor Protection
 System (RPS)

The Reactor Vessel Water Level—Low (Low Low Level) Function is required to be OPERABLE in MODES 1, 2, and 3, and during operations with a potential for draining the reactor vessel (OPDRVs) to ensure that the control room personnel are protected during a LOCA. In MODES 4 and 5 at times other than OPDRVs, the probability of a vessel draindown event resulting in a release of radioactive material into the environment is minimal. In addition, adequate protection is performed by the ~~Control Room ATP~~ Inlet Radiation—High Function. Therefore, this Function is not required in other MODES and specified conditions.

Refueling Floor Radiation
 — High and Reactor
 Building Exhaust Radiation

2. Drywell Pressure—High 3

High pressure in the drywell could indicate a break in the reactor coolant pressure boundary. A high drywell pressure

(continued)

All changes are indicated unless otherwise indicated

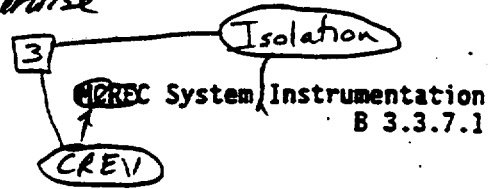

BASES

APPLICABLE SAFETY ANALYSES, LCO, and APPLICABILITY

2. Drywell Pressure—High (continued)

signal could indicate a LOCA and will automatically initiate ~~the MCREC SYSTEM~~, since this could be a precursor to a potential radiation release and subsequent radiation exposure to control room personnel.

isolation of the control room emergency zone

Drywell Pressure—High ^{switches} signals are initiated from four pressure ~~transmitters~~ that sense drywell pressure. Four channels of Drywell Pressure—High Function are available (two channels per trip system) and are required to be OPERABLE to ensure that no single instrument failure can preclude ~~MCREC SYSTEM INITIATION~~. The Drywell Pressure—High Allowable Value was chosen to be the same as the ~~ECS~~ Drywell Pressure—High Allowable Value (LCO 3.3.9.1).

control room emergency zone isolation

RPS

①

The Drywell Pressure—High Function is required to be OPERABLE in MODES 1, 2, and 3 to ensure that control room personnel are protected in the event of a LOCA. In MODES 4 and 5, the Drywell Pressure—High Function is not required since there is insufficient energy in the reactor to pressurize the drywell to the Drywell Pressure—High setpoint.

3. Main Steam Line Flow—High

isolation of the control room emergency zone

(the differential pressure switches sense differential pressure across a flow restrictor)

High main steam line (MSL) flow could indicate a break in the MSL and will automatically initiate the ~~MCREC SYSTEM~~, since this could be a precursor to a potential radiation release and subsequent radiation exposure to control room personnel.

control room envelope emergency zone isolation

differential pressure switches

The Main Steam Line Flow—High signals are initiated from 16 ~~transmitters~~ that are connected to the four MSLs. Four channels of Main Steam Line Flow—High Function for each MSL (two channels per trip system) are available and required to be OPERABLE so that no single instrument failure will preclude ~~MCREC SYSTEM INITIATION~~.

The Allowable Value was chosen to be the same as the Primary Containment Isolation Main Steam Line Flow—High Allowable Value (LCO 3.3.6.1, "Primary Containment Isolation Instrumentation").

(continued)

All changes are U unless otherwise indicated

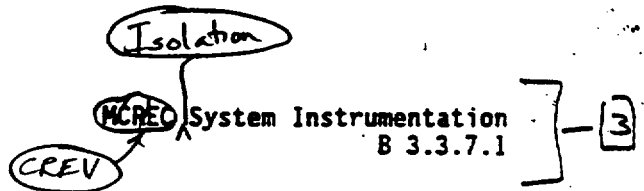

BASES

APPLICABLE SAFETY ANALYSES, LCO, and APPLICABILITY

3. Main Steam Line Flow—High (continued)

The Main Steam Line Flow—High Function is required to be OPERABLE in MODES 1, 2, and 3 to ensure that control room personnel are protected during a main steam line break (MSLB) accident. In MODES 4 and 5, the reactor is depressurized; thus, MSLB protection is not required.

3
and Reactor Building Ventilation Exhaust Radiation—High

or in the reactor building ventilation exhaust

5 3

4. Refueling Floor Area Radiation—High

High radiation in the refueling floor area could be the result of a fuel handling accident. A refueling floor high radiation signal will automatically initiate the MCREC System, since this radiation release could result in radiation exposure to control room personnel.

or a reactor building ventilation exhaust

an indication of possible gross failure of the fuel cladding. The release may have originated from the primary containment due to a break in the reactor coolant pressure boundary (RCPB) or the refuel floor due to

The Refueling Floor Area Radiation Equipment consists of two independent monitors and channels located in the refueling floor area. Two channels of Refueling Floor Area Radiation—High Function are available and are required to be OPERABLE to ensure that no single instrument failure can preclude MCREC system initiation. The Allowable Values were selected to ensure that the Function will promptly detect high activity that could threaten exposure to control room personnel.

Isolation of the control room emergency zone

and four channels of Reactor Building Ventilation Exhaust Radiation—High Function

5

The Refueling Floor Area Radiation—High Function is required to be OPERABLE in MODES 1, 2, and 3 and during movement of irradiated fuel assemblies in the secondary containment, CORE ALTERATIONS, and operations with a potential for draining the reactor vessel (OPDRVs), to ensure that control room personnel are protected during a LOCA, fuel handling event, or vessel draindown event. During MODES 4 and 5, when these specified conditions are not in progress (e.g., CORE ALTERATIONS), the probability of a LOCA or fuel damage is low; thus, the Function is not required.

and Reactor Building Ventilation Exhaust Radiation—High Function

3

5 are

Insert Functions 4 and 5

will preclude control room emergency zone isolation

5. Control Room Air Inlet Radiation—High

The control room air inlet radiation monitors measure radiation levels exterior to the inlet ducting of the MCR. A high radiation level may pose a threat to MCR personnel; thus, automatically initiating the MCREC System.

3

(continued)

1

Insert Functions 4 and 5

are initiated from radiation detectors that are located to monitor the environment of the associated spent fuel pool. The Reactor Building Ventilation Exhaust Radiation-High signals are initiated from radiation detectors that are located on the ventilation exhaust duct coming from the associated reactor building. Therefore, the channels must be declared inoperable if the associated reactor building ventilation exhaust duct is isolated.

Isolation

BASES

APPLICABLE SAFETY ANALYSES, LCO, and APPLICABILITY

5. Control Room Air Inlet Radiation—High (continued)

The Control Room Air Inlet Radiation—High Function consists of two independent monitors. Two channels of Control Room Air Inlet Radiation—High are available and are required to be OPERABLE to ensure that no single instrument failure can preclude MCREC System initiation. The Allowable Value was selected to ensure protection of the control room personnel.

The Control Room Air Inlet Radiation—High Function is required to be OPERABLE in MODES 1, 2, and 3 and during CORE ALTERATIONS, OPDRVs, and movement of irradiated fuel assemblies in the secondary containment, to ensure that control room personnel are protected during a LOCA, fuel handling event, or vessel draindown event. During MODES 4 and 5, when these specified conditions are not in progress (e.g., CORE ALTERATIONS), the probability of a LOCA or fuel damage is low; thus, the Function is not required.

3

ACTIONS

Reviewer's Note: Certain LCO Completion Times are based on approved topical reports. In order for a licensee to use the times, the licensee must justify the Completion Times as required by the staff Safety Evaluation Report (SER) for the topical report.

4

A Note has been provided to modify the ACTIONS related to MCREC System instrumentation channels. Section 1.3, Completion Times, specifies that once a Condition has been entered, subsequent divisions, subsystems, components, or variables expressed in the Condition, discovered to be inoperable or not within limits, will not result in separate entry into the Condition. Section 1.3 also specifies that Required Actions of the Condition continue to apply for each additional failure, with Completion Times based on initial entry into the Condition. However, the Required Actions for inoperable MCREC System instrumentation channels provide appropriate compensatory measures for separate inoperable channels. As such, a Note has been provided that allows separate Condition entry for each inoperable MCREC System instrumentation channel.

CREV

Isolation

CREV

CREV

Isolation

3

(continued)

All changes are [] unless otherwise indicated

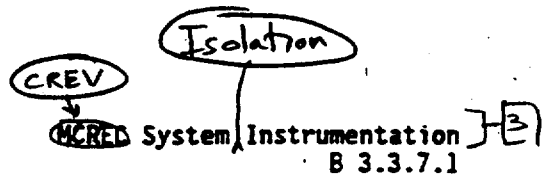

BASES

ACTIONS
(continued)

A.1

Required Action A.1 directs entry into the appropriate Condition referenced in Table 3.3.7.1-1. The applicable Condition specified in the Table is Function dependent. Each time a channel is discovered inoperable, Condition A is entered for that channel and provides for transfer to the appropriate subsequent Condition.

B.1 and B.2

Because of the diversity of sensors available to provide ~~initiation~~ signals and the redundancy of the ~~CREV~~ System design, an allowable out of service time of 24 hours has been shown to be acceptable (Refs. 4 and 5) to permit restoration of any inoperable channel to OPERABLE status. However, this out of service time is only acceptable ~~CREV~~ System ~~initiation~~ capability. A Function is considered to be maintaining ~~CREV~~ System ~~initiation~~ capability when sufficient channels are OPERABLE or in trip such that ~~one trip system will generate an initiation signal from the given function on a valid signal.~~ For Functions 4 and 5, this would require ~~one~~ trip system to have one channel ~~per logic string~~ OPERABLE or in trip (a logic string is the one-out-of-two portion of a one-out-of-two taken twice logic arrangement). For Function 3, this would require ~~one~~ trip system to have one channel ~~per logic string~~ associated with ~~CREV~~ System ~~initiation~~ capability). In this situation (loss of Required Action B.2 is not appropriate. If the Function is not maintaining ~~CREV~~ System ~~initiation~~ capability, the ~~CREV~~ System must be declared inoperable within 1 hour of discovery of the loss of ~~CREV~~ System ~~initiation~~ capability in both trip systems.

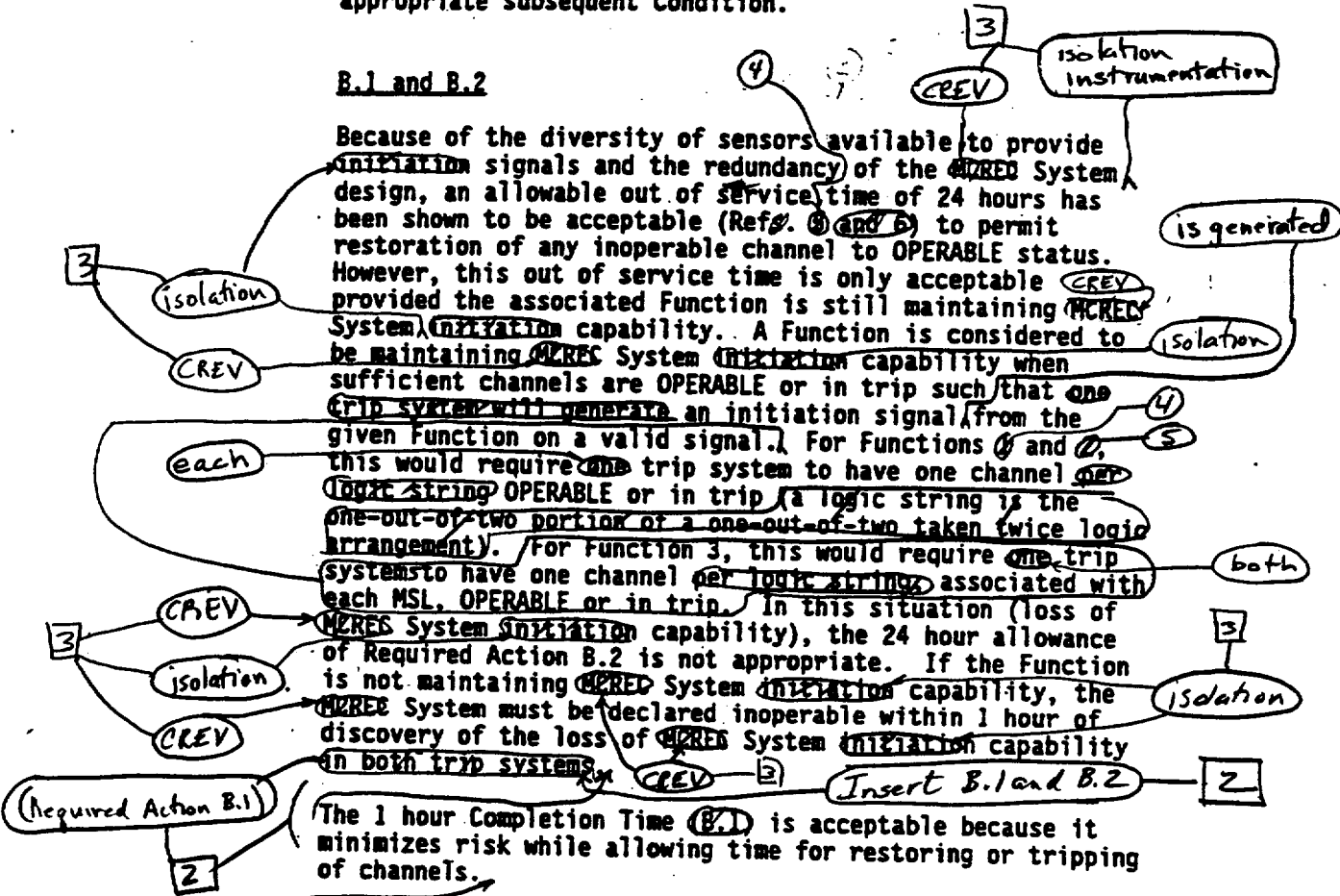

(Required Action B.1)
2

The 1 hour Completion Time (B.1) is acceptable because it minimizes risk while allowing time for restoring or tripping of channels.

If the inoperable channel cannot be restored to OPERABLE status within the allowable out of service time, the channel must be placed in the tripped condition per Required Action B.2. Placing the inoperable channel in trip would

If it is not desired to declare the CREV System inoperable, Condition D may be entered and Required Action B.1 or D.2, as applicable, taken.

(continued)

All changes are [3] unless otherwise indicated

BASES

ACTIONS B.1 and B.2 (continued)

conservatively compensate for the inoperability, restore capability to accommodate a single failure, and allow operation to continue. Alternately, if it is not desired to place the channel in trip (e.g., as in the case where placing the inoperable channel in trip would result in an ~~initiation~~), Condition D must be entered and its Required Action taken.

isolation

C.1 and C.2

has been shown to be acceptable (Ref. 4)

isolation

Because of the diversity of sensors available to provide ~~initiation~~ signals and the redundancy of the ~~CREV~~ System design, an allowable out of service time of ~~2~~ hours is ~~provided~~ to permit restoration of any inoperable channel to OPERABLE status. However, this out of service time is only acceptable provided the associated Function is still maintaining ~~CREV~~ System ~~initiation~~ capability. A Function is considered to be maintaining ~~CREV~~ System ~~initiation~~ capability when sufficient channels are OPERABLE or in trip such that ~~one~~ trip system will generate an initiation signal from the given function on a valid signal. For Functions ~~1~~ and ~~2~~, this would require ~~one~~ trip system to have one channel OPERABLE or in trip. In this situation (loss of ~~CREV~~ System ~~initiation~~ capability), the ~~2~~ hour allowance of Required Action C.2 is not appropriate. If the Function is not maintaining ~~CREV~~ System ~~initiation~~ capability, the ~~CREV~~ System must be declared inoperable within 1 hour of discovery of the loss of ~~CREV~~ System ~~initiation~~ capability in both trip systems.

CREV

instrumentation

2

isolation

CREV

both

2

isolation

CREV

2

CREV

isolation

2

Insert C.1 and C.2

The 1 hour Completion Time (C.1) is acceptable because it minimizes risk while allowing time for restoring or tripping of channels.

If it is not desired to declare the CREV System inoperable, Condition D may be entered and Required Action D1 or D.2, as applicable, taken.

If the inoperable channel cannot be restored to OPERABLE status within the allowable out of service time, the channel must be placed in the tripped condition per Required Action C.2. Placing the inoperable channel in trip performs the intended function of the channel (starts both ~~CREV~~ subsystems in the pressurization mode). Alternately, if it is not desired to place the channel in trip (e.g., as in the case where it is not desired to start the subsystem), Condition D must be entered and its Required Action taken.

placing the inoperable channel in trip would result in an isolation

(continued)

conservatively compensates for the inoperability, restores capability to accommodate a single failure, and allows operation to continue

2

INSERT C.1 and C.2

(Required Action C.1). This Completion Time also allows for an exception to the normal "time zero" for beginning the allowed outage time "clock." For Required Action C.1, the Completion Time only begins upon discovery that the CREV System cannot be automatically isolated due to inoperable, untripped channels in the same Function in one trip system.

All changes are [3] unless otherwise indicated

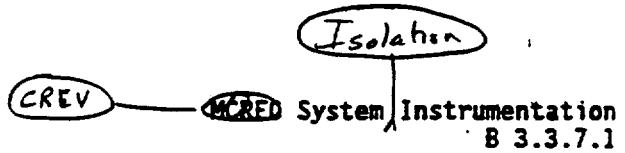

BASES

ACTIONS

C.1 and C.2 (continued)

The 6 hour Completion Time is based on the consideration that this Function provides the primary signal to start the MCREC System; thus, ensuring that the design basis of the MCREC System is met.

D.1, D.2, and D.3

each required control room penetration flow path isolated

With any Required Action and associated Completion Time not met, the associated MCREC subsystem(s) must be placed in the pressurization mode of operation per Required Action D.1 to ensure that control room personnel will be protected in the event of a Design Basis Accident. The method used to place the MCREC subsystem(s) in operation must provide for automatically re-initiating the subsystem(s) upon restoration of power following a loss of power to the MCREC subsystem(s). As noted, if the toxic gas protection instrumentation is concurrently inoperable, then the MCREC subsystem(s) should be placed in the toxic gas mode instead of the pressurization mode. This provides proper protection of the control room personnel if both toxic gas instrumentation (not required by Technical Specifications) and radiation instrumentation are concurrently inoperable.

Alternately, if a Function 3 channel is inoperable and untripped, the associated MSL may be isolated, since isolating the MSL performs the intended function of the MCREC System instrumentation. Alternately, if it is not desired to start the subsystem(s) or isolate the MSL, the MCREC subsystem(s) associated with inoperable, untripped channels must be declared inoperable within 1 hour.

isolate each required control room penetration flow path

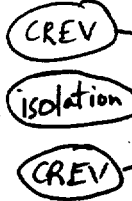

The 1 hour Completion Time is intended to allow the operator time to place the MCREC subsystem(s) in operation or to isolate the associated MSLs if applicable. The 1 hour Completion Time is acceptable because it minimizes risk while allowing time for restoration or tripping of channels, for placing the associated MCREC subsystem(s) in operation, for isolating the associated MSLs, or for entering the applicable Conditions and Required Actions for the inoperable MCREC subsystem(s).

isolating each required control room penetration flow path



(continued)

All changes are [3] unless otherwise indicated

CREV → MCRED System Instrumentation B 3.3.7.1
Isolation

BASES (continued)

SURVEILLANCE REQUIREMENTS

Reviewer's Note: Certain Frequencies are based on approved topical reports. In order for a licensee to use these Frequencies, the licensee must justify the Frequencies as required by the staff SER for the topical report. [4]

isolation As noted at the beginning of the SRs, the SRs for each System Instrumentation Function are located in the SRs column of Table 3.3.7.1-1. MCRED CREV

isolation The Surveillances are modified by a Note to indicate that when a channel is placed in an inoperable status solely for performance of required Surveillances, entry into associated Conditions and Required Actions may be delayed for up to 6 hours, provided the associated Function maintains System ~~initiation~~ capability. Upon completion of the Surveillance, or expiration of the 6 hour allowance, the channel must be returned to OPERABLE status or the applicable Condition entered and Required Actions taken. This Note is based on the reliability analysis (Ref. B₅ [4] [1] [5]) assumption of the average time required to perform channel surveillance. That analysis demonstrated that the 6 hour testing allowance does not significantly reduce the probability that the MCRED System will ~~initiate~~ when necessary. CREV isolate

SR 3.3.7.1.1

Performance of the CHANNEL CHECK once every 12 hours ensures that a gross failure of instrumentation has not occurred. A CHANNEL CHECK is normally a comparison of the parameter indicated on one channel to a similar parameter on other channels. It is based on the assumption that instrument channels monitoring the same parameter should read approximately the same value. Significant deviations between the instrument channels could be an indication of excessive instrument drift in one of the channels or something even more serious. A CHANNEL CHECK will detect gross channel failure; thus, it is key to verifying the instrumentation continues to operate properly between each CHANNEL CALIBRATION.

Agreement criteria are determined by the plant staff, based on a combination of the channel instrument uncertainties, including indication and readability. If a channel is

(continued)

All changes are [1] unless otherwise indicated

CREV

Isolation

SECRET System Instrumentation B 3.3.7.1

[3]

BASES

SURVEILLANCE REQUIREMENTS

SR 3.3.7.1.1 (continued)

outside the criteria, it may be an indication that the instrument has drifted outside its limit.

The Frequency is based upon operating experience that demonstrates channel failure is rare. The CHANNEL CHECK supplements less formal, but more frequent, checks of channel, ~~STATUS~~ during normal operational use of the displays associated with channels required by the LCO.

SR 3.3.7.1.2

A CHANNEL FUNCTIONAL TEST is performed on each required channel to ensure that the ~~entire~~ channel will perform the intended function.

[2]

Any setpoint adjustment shall be consistent with the assumptions of the current plant specific setpoint methodology.

The Frequency of 92 days is based on the reliability analyses of References ~~4~~ and ~~6~~.

[1]

SR 3.3.7.1.3

The calibration of trip units provides a check of the actual trip setpoints. Any setpoint adjustment shall be consistent with the assumptions of the current plant specific setpoint methodology. The channel must be declared inoperable if the trip setting is discovered to be less conservative than the Allowable Value specified in Table 3.3.7.1-1. If the trip setting is discovered to be less conservative than accounted for in the appropriate setpoint methodology, but is not beyond the Allowable Value, the channel performance is still within the requirements of the plant safety analysis. Under these conditions, the setpoint must be readjusted to be equal to or more conservative than the setting accounted for in the appropriate setpoint methodology.

The Frequency of 92 days is based on the reliability analyses of References ~~4~~ and ~~6~~.

(continued)

All changes are unless otherwise indicated

Isolation

System Instrumentation B 3.3.7.1

CREV

BASES

SURVEILLANCE REQUIREMENTS (continued)

SR 3.3.7.1.4 and SR 3.3.7.1.5

A CHANNEL CALIBRATION is a complete check of the instrument loop and the sensor. This test verifies the channel responds to the measured parameter within the necessary range and accuracy. CHANNEL CALIBRATION leaves the channel adjusted to account for instrument drifts between successive calibrations consistent with the plant specific setpoint methodology.

92 day

of SR 3.3.7.1.4 and the 24 month Frequency of SR 3.3.7.1.5

The Frequency is based upon the assumption of a 12 month calibration interval in the determination of the magnitude of equipment drift in the setpoint analysis.

respectively

are

92 day and

SR 3.3.7.1.4-6

The LOGIC SYSTEM FUNCTIONAL TEST demonstrates the OPERABILITY of the required initiation logic for a specific channel. The system functional testing performed in LCO 3.7.4, "Main Control Room Environmental Control System," overlaps this Surveillance to provide complete testing of the assumed safety function.

3

24

CREV

Emergency Ventilation

The 12 month Frequency is based on the need to perform this Surveillance under the conditions that apply during a plant outage and the potential for an unplanned transient if the Surveillance were performed with the reactor at power. Operating experience has shown these components usually pass the Surveillance when performed at the 12 month Frequency.

24

REFERENCES

- 1. FSAR, Figure [].
- 2. FSAR, Section 6.4.1.
- 3. FSAR, Section 6.A.1.7.2.
- 4. FSAR, Table 15.Y.28.
- 5. VFSAR, Section 15.6.5.
- 6. GENE-770-06-1, "Bases for Changes to Surveillance Test Intervals and Allowed Out-of-Service Times for Selected Instrumentation Technical Specifications," February 1992.

December 1992

(continued)

CREV

Isolation

3

System Instrumentation
B 3.3.7.1

BASES

REFERENCES
(continued)

6. NEDC-31677P-A, "Technical Specification Improvement Analysis for BWR Isolation Actuation Instrumentation," July 1990.

1

JUSTIFICATION FOR DEVIATIONS FROM NUREG-1433, REVISION 1
ITS BASES: 3.3.7.1 - CREV SYSTEM ISOLATION INSTRUMENTATION

1. Changes have been made (additions, deletions, and/or changes to the NUREG) to reflect the plant specific methodology, nomenclature, number reference, system description, analysis description, or licensing basis description..
2. Editorial change made for enhanced clarity or to be consistent with similar statements in other places in the Bases.
3. Changes have been made to reflect those changes made to the Specification.
4. This Reviewer's Note has been deleted. This information is for the NRC reviewer to be keyed in to what is needed to meet this requirement. This is not meant to be retained in the final version of the plant specific submittal.
5. The brackets have been removed and the proper plant specific information/value has been provided.

0

B 3.3 INSTRUMENTATION

B 3.3.7.2 Mechanical Vacuum Pump Trip Instrumentation

BASES

BACKGROUND

The Mechanical Vacuum Pump Trip Instrumentation initiates a trip of the main condenser mechanical vacuum pump breaker following events in which main steam line radiation exceeds predetermined values. Tripping the mechanical vacuum pump limits the offsite and control room doses in the event of a control rod drop accident (CRDA).

The Mechanical Vacuum Pump Trip Instrumentation (Refs. 1 and 2) includes detectors, monitors, and relays that are necessary to cause initiation of a mechanical vacuum pump trip. The channels include electronic equipment that compares measured input signals with pre-established setpoints. When the setpoint is exceeded, the channel output relay actuates, which then outputs an isolation signal to the mechanical vacuum pump trip logic.

The trip logic consists of two independent trip systems, with two channels of Main Steam Line Radiation-High in each trip system. Each trip system is a one-out-of-two logic for this function. Thus, either channel of Main Steam Line Radiation-High in each trip system is needed to trip a trip system. The outputs of the channels in a trip system are combined in a one-out-of-two taken twice logic so that both trip systems must trip to result in a pump trip signal.

There is one isolation valve and two mechanical vacuum pump breakers associated with this function.

APPLICABLE SAFETY ANALYSES

The Mechanical Vacuum Pump Trip Instrumentation is assumed in the safety analysis for the CRDA. The Mechanical Vacuum Pump Trip Instrumentation initiates a trip of the mechanical vacuum pump to limit offsite and control room doses resulting from fuel cladding failure in a CRDA (Ref. 3)

The mechanical vacuum pump trip instrumentation satisfies Criterion 3 of 10 CFR 50.36(c)(2)(ii).

(continued)

11

BASES (continued)

LCO

The OPERABILITY of the mechanical vacuum pump trip is dependent on the OPERABILITY of the individual Main Steam Line Radiation-High instrumentation channels, which must have a required number of OPERABLE channels in each trip system, with their setpoints within the specified Allowable Value of SR 3.3.7.2.4. The actual setpoint is calibrated consistent with applicable setpoint methodology assumptions. Channel OPERABILITY also includes the mechanical vacuum pump breaker.

An Allowable Value is specified for the Main Steam Line Radiation-High Trip Function specified in the LCO. The nominal trip setpoint is specified in the setpoint calculations. The nominal setpoint is selected to ensure that the setpoint does not exceed the Allowable Value between CHANNEL CALIBRATIONS. Operation with a trip setpoint less conservative than the nominal trip setpoint, but within its Allowable Value, is acceptable. A channel is inoperable if its actual trip setpoint is not within its required Allowable Value. The trip setpoint is that predetermined value of output at which an action should take place. The setpoint is compared to the actual process parameter (i.e., main steam line radiation) and when the measured output value of the process parameter exceeds the setpoint, the associated device (e.g., trip auxiliary unit) changes state. The analytic limit is derived from the limiting value of the process parameter obtained from the safety analysis. The trip setpoints are determined from the analytic limits, corrected for defined process, calibration, and instrument errors. The Allowable Values are then determined, based on the trip setpoint values, by accounting for the calibration based errors. These calibration based errors are limited to reference accuracy, instrument drift, errors associated with measurement and test equipment, and calibration tolerance of loop components. The trip setpoints and Allowable Values determined in this manner provide adequate protection because instrument uncertainties, process effects, calibration tolerances, instrument drift, and severe environment errors (for channels that must function in harsh environments as defined by 10 CFR 50.49) are accounted for and appropriately applied for the instrumentation.

(continued)

BASES

ACTIONS

A.1 and A.2 (continued)

result in the inability of the Mechanical Vacuum Pump Trip Instrumentation to perform the intended function. Therefore, only a limited time is allowed to restore the inoperable channels to OPERABLE status. Because of the low probability of extensive numbers of inoperabilities affecting multiple channels, and the low probability of an event requiring the initiation of mechanical vacuum pump trip, 12 hours has been shown to be acceptable (Ref. 4) to permit restoration of any inoperable channel to OPERABLE status (Required Action A.1). Alternately, the inoperable channel, may be placed in trip (Required Action A.2), since this would conservatively compensate for the inoperability, restore capability to accommodate a single failure, and allow operation to continue. As noted, placing the channel in trip with no further restrictions is not allowed if the inoperable channel is the result of an inoperable mechanical vacuum pump breaker, since this may not adequately compensate for the inoperable breaker. If it is not desired to place the channel in trip (e.g., as in the case where placing the inoperable channel in trip would result in loss of condenser vacuum), or if the inoperable channel is the result of an inoperable breaker, Condition C must be entered and its Required Actions taken.

B.1

Condition B is intended to ensure that appropriate actions are taken if multiple, inoperable, untripped channels within the same trip system result in not maintaining mechanical vacuum pump trip capability. The mechanical vacuum pump trip capability is maintained when sufficient channels are OPERABLE or in trip such that the Mechanical Vacuum Pump Trip Instrumentation will generate a trip signal from a valid Main Steam Line Radiation-High signal, and the mechanical vacuum pump breaker will open. This would require both trip systems to have one channel OPERABLE or in trip, and the mechanical vacuum pump breaker to be OPERABLE.

The Completion Time is intended to allow the operator time to evaluate and repair any discovered inoperabilities. The Completion Time is acceptable because it minimizes risk while allowing time for restoration or tripping of channels.

(continued)

BASES

ACTIONS
(continued)

C.1, C.2, C.3, and C.4

With any Required Action and associated Completion Time not met, the plant must be brought to a MODE or other specified condition in which the LCO does not apply. To achieve this status, the plant must be brought to at least MODE 3 within 12 hours (Required Action C.4). Alternately, the associated mechanical vacuum pump may be removed from service since this performs the intended function of the instrumentation (Required Actions C.1 and C.2). An additional option is provided to isolate the main steam lines (Required Action C.3), which may allow operation to continue. Isolating the main steam lines effectively provides an equivalent level of protection by precluding fission product transport to the condenser.

The allowed Completion Time of 12 hours is reasonable, based on operating experience, to reach MODE 3 from full power conditions, or to remove the mechanical vacuum pump from service, or to isolate the main steam lines, in an orderly manner and without challenging plant systems.

SURVEILLANCE
REQUIREMENTS

The Surveillances are modified by a Note to indicate that when a channel is placed in an inoperable status solely for performance of required Surveillances, entry into the associated Conditions and Required Actions may be delayed for up to 6 hours provided mechanical vacuum pump trip capability is maintained. Upon completion of the Surveillance, or expiration of the 6 hour allowance, the channel must be returned to OPERABLE status or the applicable Condition entered and Required Actions taken. This Note is based on the reliability analysis (Ref. 4) assumption of the average time required to perform channel Surveillance. That analysis demonstrated that the 6 hour testing allowance does not significantly reduce the probability that the mechanical vacuum pump will trip when necessary.

SR 3.3.7.2.1

Performance of the CHANNEL CHECK once every 12 hours ensures that a gross failure of instrumentation has not occurred. A CHANNEL CHECK is normally a comparison of the parameter

(continued)

BASES

SURVEILLANCE
REQUIREMENTS

SR 3.3.7.2.1 (continued)

indicated on one channel to a similar parameter on other channels. It is based on the assumption that instrument channels monitoring the same parameter should read approximately the same value. Significant deviations between the instrument channels could be an indication of excessive instrument drift in one of the channels or something even more serious. A CHANNEL CHECK will detect gross channel failure; thus, it is key to verifying the instrumentation continues to operate properly between each CHANNEL CALIBRATION.

Agreement criteria are determined by the plant staff based on a combination of the channel instrument uncertainties, including indication and readability. If a channel is outside the criteria, it may be an indication that the instrument has drifted outside its limit.

The Frequency is based upon operating experience that demonstrates channel failure is rate. The CHANNEL CHECK supplements less formal, but more frequent, checks of channels during normal operational use of the displays associated with the required channels of this LCO.

SR 3.3.7.2.2

A CHANNEL FUNCTIONAL TEST is performed on each required channel to ensure that the channel will perform the intended function. Any setpoint adjustment shall be consistent with the assumptions of the current plant specific setpoint methodology.

The Frequency of 92 days is based on the reliability analysis of Reference 4.

SR 3.3.7.2.3 and SR 3.3.7.2.4

A CHANNEL CALIBRATION is a complete check of the instrument loop and the sensor. This test verifies the channel responds to the measured parameter within the necessary

(continued)

11

BASES

SURVEILLANCE
REQUIREMENTS

SR 3.3.7.2.3 and SR 3.3.7.2.4 (continued)

range and accuracy. CHANNEL CALIBRATION leaves the channel adjusted to account for instrument drifts between successive calibrations consistent with the plant specific setpoint methodology. A Note to SR 3.3.7.2.3 states that radiation detectors are excluded from CHANNEL CALIBRATION since they are calibrated in accordance with SR 3.3.7.2.4.

The Frequency of SR 3.3.7.2.3 is based upon the assumption of a 92 day calibration interval in the determination of the magnitude of equipment drift associated with the channel, except for the radiation detectors, in the setpoint analysis. The Frequency of SR 3.3.7.2.4 is based upon the assumption of a 24 month calibration interval in the determination of the magnitude of equipment drift for the radiation detector in the setpoint analysis.

SR 3.3.7.2.5

The LOGIC SYSTEM FUNCTIONAL TEST demonstrates the OPERABILITY of the required trip logic for a specific channel. The system functional test of the mechanical vacuum pump breakers and isolation valve is included as part of this Surveillance and overlaps the LOGIC SYSTEM FUNCTIONAL TEST to provide complete testing of the assumed safety function. Therefore, if a breaker or the isolation valve is incapable of operating, the associated instrument channel(s) would be inoperable.

The 24 month Frequency is based on the need to perform this Surveillance under the conditions that apply during a plant outage and the potential for an unplanned transient if the Surveillance were performed with the reactor at power. Operating experience has shown these components usually pass the Surveillance when performed at the 24 month Frequency.

(continued)

11

BASES (continued)

- REFERENCES
1. UFSAR, Section 7.3.2.2.2.
 2. UFSAR, Section 11.5.2.6.
 3. UFSAR, Section 15.4.10.
 4. NEDC-30851-P-A, "Supplement 2, "Technical Specifications Improvement Analysis for BWR Isolation Instrumentation Common to RPS and ECCS Instrumentation," March 1989.
-

JUSTIFICATION FOR DEVIATIONS FROM NUREG-1433, REVISION 1
ITS BASES: 3.3.7.2 - MECHANICAL VACUUM PUMP TRIP INSTRUMENTATION

1. A new Specification (ITS 3.3.7.2, "Mechanical Vacuum Pump Trip Instrumentation"), and as a result a corresponding Bases, has been added consistent with the current licensing basis.

B 3.3 INSTRUMENTATION

B 3.3.8.1 Loss of Power (LOP) Instrumentation

BASES

4160 V Essential Service System (ESS) [2]

BACKGROUND

Successful operation of the required safety functions of the Emergency Core Cooling Systems (ECCS) is dependent upon the availability of adequate power sources for energizing the various components such as pump motors, motor operated valves, and the associated control components. The LOP instrumentation monitors the ~~4.16 kV~~ emergency buses. Offsite power is the preferred source of power for the ~~4.16 kV~~ emergency buses. If the monitors determine that insufficient power is available, the buses are disconnected from the offsite power sources and connected to the onsite diesel generator (DG) power sources.

[2] 4160V ESS

[3] Voltage

Each ~~4.16 kV~~ emergency bus has its own independent LOP instrumentation and associated trip logic. The voltage for each bus is monitored at two levels, which can be considered as two different undervoltage functions: Loss of Voltage and ~~4.16 kV Emergency Bus Undervoltage~~ Degraded Voltage.

[1] A

Each function causes various bus transfers and disconnects.

Each function is monitored by two undervoltage relays for each emergency bus, whose outputs are arranged in a two-out-of-two logic configuration (Ref. 1). The channels include electronic equipment (e.g., trip units) that compares measured input signals with pre-established setpoints. When the setpoint is exceeded, the channel output relay actuates, which then outputs a LOP trip signal to the trip logic.

[2] Division 1 and 2 4160 V ESS Bus Loss of Voltage and Degraded Voltage

ESS

Insert BKGD [2]

APPLICABLE SAFETY ANALYSES, LCO, and APPLICABILITY

The LOP instrumentation is required for Engineered Safety Features to function in any accident with a loss of offsite power. The required channels of LOP instrumentation ensure that the ECCS and other assumed systems powered from the DGs, provide plant protection in the event of any of the Reference 2, 3, and 4 analyzed accidents in which a loss of offsite power is assumed. The initiation of the DGs on loss of offsite power, and subsequent initiation of the ECCS, ensure that the fuel peak cladding temperature remains below the limits of 10 CFR 50.46.

(continued)

Insert BKGD

When, on decreasing voltage, the 4160 V ESS Bus Undervoltage (Loss of Voltage) Function setpoint has been exceeded on both relay channels, the Loss of Voltage Function sends a LOP signal to the respective bus load shedding scheme and starts the associated DG. For the Degraded Voltage Function, one Bus Undervoltage/Time Delay Function (two channels) and one Time Delay Function (one channel) are included. The Time Delay Function associated with the Bus Undervoltage relay is inherent to the Bus Undervoltage - Degraded Voltage relay and is nominally adjusted to seven seconds to prevent circuit initiation caused by grid disturbances and motor starting transients. The Bus Undervoltage/Time Delay Function provides input to the Time Delay Function. The Time Delay Function relay is nominally adjusted to five minutes to allow time for the operator to attempt to restore normal bus voltage. When a Bus Undervoltage/Time Delay Function setpoint has been exceeded and persists for seven seconds on both relay channels, a control room annunciator alerts the operator of the degraded voltage condition and the five minute Time Delay Function timer is initiated. If the degraded voltage condition does not clear within five minutes, the five minute Time Delay Function relay sends a LOP signal to the respective bus load shedding scheme and starts the associated DG. If a degraded voltage condition exists coincident with an ECCS actuation signal, the five minute Time Delay Function is bypassed such that load shedding and the associated DG start will be initiated following the seven second time delay (Bus Undervoltage/Time Delay Function).

BASES

APPLICABLE
SAFETY ANALYSES,
LCO, and
APPLICABILITY
(continued)

Accident analyses credit the loading of the DG based on the loss of offsite power (during) a loss of coolant accident. The diesel starting and loading times have been included in the delay time associated with each safety system component requiring DG supplied power following a loss of offsite power.

(LOCA) 1
Coincident with 2

The LOP instrumentation satisfies Criterion 3 of the NRC Policy/Statement.

10 CFR 50.36 (c)(2)(ii)

The OPERABILITY of the LOP instrumentation is dependent upon the OPERABILITY of the individual instrumentation channel Functions specified in Table 3.3.8.1-1. Each Function must have a required number of OPERABLE channels per 4160 V ESS emergency bus, with their setpoints within the specified Allowable Values. A channel is inoperable if its actual trip setpoint is not within its required Allowable Value. The actual setpoint is calibrated consistent with applicable setpoint methodology assumptions.

2
4160 V ESS

The Allowable Values are specified for each Function in the Table. Nominal trip setpoints are specified in the setpoint calculations. The nominal setpoints are selected to ensure that the setpoints do not exceed the Allowable Value between CHANNEL CALIBRATIONS. Operation with a trip setpoint less conservative than the nominal trip setpoint, but within the Allowable Value, is acceptable. Trip setpoints are those predetermined values of output at which an action should take place. The setpoints are compared to the actual process parameter (e.g., degraded voltage), and when the measured output value of the process parameter exceeds the setpoint, the associated device (e.g., Trip Unit) changes state. The analytic limits are derived from the limiting values of the process parameters obtained from the safety analysis. The Allowable Values are derived from the analytic limits, corrected for calibration, process, and some of the instrument errors. The trip setpoints are then determined accounting for the remaining instrument errors (e.g., drift). The trip setpoints derived in this manner provide adequate protection because instrumentation uncertainties, process effects, calibration tolerances, instrument drift, and severe environment errors (for channels that must function in harsh environments as defined by 10 CFR 50.49) are accounted for.

2
Insert ASA

(continued)

2

Insert ASA

The trip setpoints are determined from the analytic limits, corrected for defined process, calibration, and instrument errors. The Allowable Values are then determined, based on the trip setpoint values, by accounting for the calibration based errors. These calibration based errors are limited to reference accuracy, instrument drift, errors associated with measurement and test equipment, and calibration tolerance of loop components. The trip setpoints and Allowable Values determined in this manner provide adequate protection because instrument uncertainties, process effects, calibration tolerances, instrument drift, and severe environment errors (for channels that must function in harsh environments as defined by 10 CFR 50.49) are accounted for and appropriately applied for the instrumentation.

BASES

APPLICABLE SAFETY ANALYSES, LCO, and APPLICABILITY (continued)

The specific Applicable Safety Analyses, LCO, and Applicability discussions are listed below on a Function by Function basis.

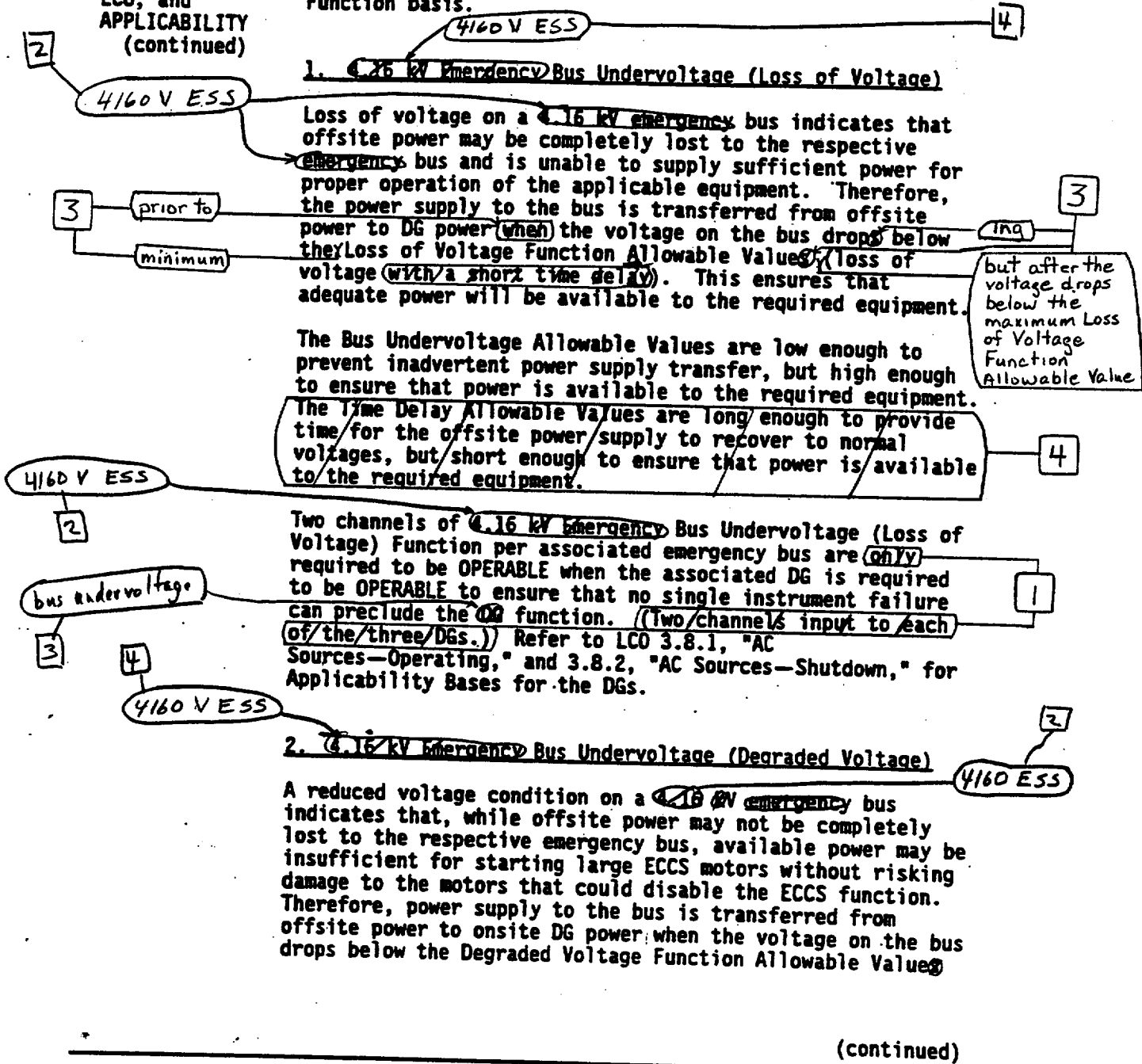

BASES

4160 V. ESS [4]

2 APPLICABLE SAFETY ANALYSES, LCO, and APPLICABILITY

however the transfer does not occur until after the inherent and No LOCA time delays have elapsed, as applicable. If a LOCA condition exists coincident with a loss of power to the bus, the Time Delay (No LOCA) Function is bypassed.

2. ~~4.16 kV Emergency~~ Bus Undervoltage (Degraded Voltage) (continued)

~~(degraded voltage with a time delay)~~. This ensures that adequate power will be available to the required equipment.

The Bus Undervoltage Allowable Values are low enough to prevent inadvertent power supply transfer, but high enough to ensure that sufficient power is available to the required equipment. The Time Delay Allowable Values are long enough to provide time for the offsite power supply to recover to normal voltages, but short enough to ensure that sufficient power is available to the required equipment.

2 or allow restoration

4 and one channel of Degraded Voltage Time Delay Function

Two channels of ~~4.16 kV Emergency~~ Bus Undervoltage (Degraded Voltage) Function per associated bus are ~~(only)~~ required to be OPERABLE when the associated DG is required to be OPERABLE to ensure that no single instrument failure can preclude the ~~DG~~ function. ~~(Two channels input to each of the three emergency buses and DGs.)~~ Refer to LCO 3.8.1 and LCO 3.8.2 for Applicability Bases for the DGs.

4160 V. ESS [4]

/Time Delay [4]

1

degraded voltage and time delay [2]

ACTIONS

A Note has been provided to modify the ACTIONS related to LOP instrumentation channels. Section 1.3, Completion Times, specifies that once a Condition has been entered, subsequent divisions, subsystems, components, or variables expressed in the Condition, discovered to be inoperable or not within limits, will not result in separate entry into the Condition. Section 1.3 also specifies that Required Actions of the Condition continue to apply for each additional failure, with Completion Times based on initial entry into the Condition. However, the Required Actions for inoperable LOP instrumentation channels provide appropriate compensatory measures for separate inoperable channels. As such, a Note has been provided that allows separate Condition entry for each inoperable LOP instrumentation channel.

A.1

With one or more channels of a Function inoperable, the Function is not capable of performing the intended function. Therefore, only 1 hour is allowed to restore the inoperable

(continued)

BASES

ACTIONS

A.1 (continued)

channel to OPERABLE status. If the inoperable channel cannot be restored to OPERABLE status within the allowable out of service time, the channel must be placed in the tripped condition per Required Action A.1. Placing the inoperable channel in trip would conservatively compensate for the inoperability, restore capability to accommodate a single failure (within the LOP instrumentation), and allow operation to continue. Alternately, if it is not desired to place the channel in trip (e.g., as in the case where placing the channel in trip would result in a DG initiation), Condition B must be entered and its Required Action taken.

The Completion Time is intended to allow the operator time to evaluate and repair any discovered inoperabilities. The 1 hour Completion Time is acceptable because it minimizes risk while allowing time for restoration or tripping of channels.

B.1

If any Required Action and associated Completion Time are not met, the associated Function is not capable of performing the intended function. Therefore, the associated DG(s) is declared inoperable immediately. This requires entry into applicable Conditions and Required Actions of LCO 3.8.1 and LCO 3.8.2, which provide appropriate actions for the inoperable DG(s).

SURVEILLANCE REQUIREMENTS

As noted, at the beginning of the SRs, the SRs for each LOP instrumentation Function are located in the SRs column of Table 3.3.8.1-1.

The Surveillances are modified by a Note to indicate that when a channel is placed in an inoperable status solely for performance of required Surveillances, entry into associated Conditions and Required Actions may be delayed for up to 2 hours provided the associated Function maintains **LOP** initiation capability. Upon completion of the Surveillance, or expiration of the 2-hour allowance, the channel must be

LOP initiation capability is maintained provided the bus load shedding scheme and the associated DG can be initiated by the Loss of Voltage or Degraded Voltage Functions for one of the two 4160V ESS buses. (continued)

BASES

SURVEILLANCE
REQUIREMENTS
(continued)

returned to OPERABLE status or the applicable Condition entered and Required Actions taken.

SR 3.3.8.1.1

Performance of the CHANNEL CHECK once every 12 hours ensures that a gross failure of instrumentation has not occurred. A CHANNEL CHECK is normally a comparison of the parameter indicated on one channel to a similar parameter on other channels. It is based on the assumption that instrument channels monitoring the same parameter should read approximately the same value. Significant deviations between the instrument channels could be an indication of excessive instrument drift in one of the channels or something even more serious. A CHANNEL CHECK will detect gross channel failure; thus, it is key to verifying the instrumentation continues to operate properly between each CHANNEL CALIBRATION.

Agreement criteria are determined by the plant staff based on a combination of the channel instrument uncertainties, including indication and readability. If a channel is outside the criteria, it may be an indication that the instrument has drifted outside its limit.

The Frequency is based upon operating experience that demonstrates channel failure is rare. The CHANNEL CHECK supplements less formal, but more frequent, checks of channels during normal operational use of the displays associated with channels required by the LCO.

4

SR 3.3.8.1.2

① — 4

A CHANNEL FUNCTIONAL TEST is performed on each required channel to ensure that the entire channel will perform the intended function. Any setpoint adjustment shall be consistent with the assumptions of the current plant specific setpoint methodology.

1

The Frequency of 37 days is based on operating experience with regard to channel OPERABILITY and drift, which demonstrates that failure of more than one channel of a given function in any 37 day interval is a rare event.

4
24 month

(continued)

BASES

SURVEILLANCE
REQUIREMENTS
(continued)

SR 3.3.8.1.1 (2) — [4]

A CHANNEL CALIBRATION is a complete check of the instrument loop and the sensor. This test verifies the channel responds to the measured parameter within the necessary range and accuracy. CHANNEL CALIBRATION leaves the channel adjusted to account for instrument drifts between successive calibrations consistent with the plant specific setpoint methodology.

Any setpoint adjustment shall be consistent with the assumptions of the current plant specific setpoint methodology.

[1]
[4]

The Frequency is based upon the assumption of a 18 month calibration interval in the determination of the magnitude of equipment drift in the setpoint analysis.

SR 3.3.8.1.2 (3) — [4]

The LOGIC SYSTEM FUNCTIONAL TEST demonstrates the OPERABILITY of the required actuation logic for a specific channel. The system functional testing performed in LCO 3.8.1 and LCO 3.8.2 overlaps this Surveillance to provide complete testing of the assumed safety functions.

The 18 month Frequency is based on the need to perform this Surveillance under the conditions that apply during a plant outage and the potential for an unplanned transient if the Surveillance were performed with the reactor at power. Operating experience has shown these components usually pass the Surveillance when performed at the 18 month Frequency.

[24] [4]

[2] REFERENCES

- Section 8.3.1.8
1. FSAR, Figure []
 2. FSAR, Section 5.2.
 3. FSAR, Section 6.3.
 4. FSAR, Chapter 15.

[5]

JUSTIFICATION FOR DEVIATIONS FROM NUREG-1433, REVISION 1
ITS BASES: 3.3.8.1 - LOSS OF POWER INSTRUMENTATION

1. Editorial change made for enhanced clarity or to be consistent with similar statements in other places in the Bases.
2. Changes have been made (additions, deletions, and/or changes to the NUREG) to reflect the plant specific methodology, nomenclature, number, reference, system description, analysis description, or licensing basis description.
3. Changes have been made to more closely reflect the Specification requirements.
4. Changes have been made to reflect those changes made to the Specification. The following requirements have been renumbered, where applicable, to reflect the changes.
5. The brackets have been removed and the proper plant specific information/value has been provided.

All changes are 1 unless noted otherwise

RPS Electric Power Monitoring
B 3.3.8.2

B 3.3 INSTRUMENTATION

B 3.3.8.2 Reactor Protection System (RPS) Electric Power Monitoring

BASES

BACKGROUND

RPS Electric Power Monitoring System is provided to isolate the RPS bus from the motor generator (MG) set or an alternate power supply in the event of overvoltage, undervoltage, or underfrequency. This system protects the loads connected to the RPS bus against unacceptable voltage and frequency conditions (Ref. 1) and forms an important part of the primary success path of the essential safety circuits. Some of the essential equipment powered from the RPS buses includes the RPS logic, scram solenoids, and pilot valve various valve isolation logic.

2
The

RPS electric power monitoring assembly will detect any abnormal high or low voltage or low frequency condition in the outputs of the two MG sets or the alternate power supply and will de-energize its respective RPS bus, thereby causing all safety functions normally powered by this bus to de-energize.

In the event of failure of an RPS Electric Power Monitoring System (e.g., both in-series electric power monitoring assemblies), the RPS loads may experience significant effects from the unregulated power supply. Deviation from the nominal conditions can potentially cause damage to the scram solenoids and other Class 1E devices.

pilot valve

In the event of a low voltage condition for an extended period of time, the scram solenoids can chatter and potentially lose their pneumatic control capability, resulting in a loss of primary scram action.

In the event of an overvoltage condition, the RPS logic relays and scram solenoids, as well as the main steam isolation/valve (MSIV) solenoids, may experience a voltage higher than their design voltage. If the overvoltage condition persists for an extended time period, it may cause equipment degradation and the loss of plant safety function.

Two redundant Class 1E circuit breakers are connected in series between each RPS bus and its MG set, and between each RPS bus and its alternate power supply. Each of these

(continued)

BASES

BACKGROUND
(continued)

3

inservice

circuit breakers has an associated independent set of Class 1E overvoltage, undervoltage, and underfrequency sensing logic. Together, a circuit breaker and its sensing logic constitute an electric power monitoring assembly. If the output of the MG set exceeds predetermined limits of overvoltage, undervoltage, or underfrequency, a trip coil driven by this logic circuitry opens the circuit breaker, which removes the associated power supply from service.

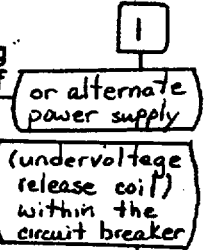

APPLICABLE SAFETY ANALYSES

The RPS electric power monitoring is necessary to meet the assumptions of the safety analyses by ensuring that the equipment powered from the RPS buses can perform its intended function. RPS electric power monitoring provides protection to the RPS and other systems that receive power from the RPS buses, by acting to disconnect the RPS from the power supply under specified conditions that could damage the RPS bus powered equipment.

3 1

3

3

RPS electric power monitoring satisfies Criterion 3 of the NRC Policy Statement:

10 CFR 50.36(c)(2)(ii)

1

LCO

The OPERABILITY of each RPS electric power monitoring assembly is dependent on the OPERABILITY of the overvoltage, undervoltage, and underfrequency logic, as well as the OPERABILITY of the associated circuit breaker. Two electric power monitoring assemblies are required to be OPERABLE for each inservice power supply. This provides redundant protection against any abnormal voltage or frequency conditions to ensure that no single RPS electric power monitoring assembly failure can preclude the function of RPS bus powered components. Each inservice electric power monitoring assembly's trip logic setpoints are required to be within the specified Allowable Value. The actual setpoint is calibrated consistent with applicable setpoint methodology assumptions.

3

of the

15

Allowable Values are specified for each RPS electric power monitoring assembly trip logic (refer to SR 3.3.8.2.2). Nominal trip setpoints are specified in the setpoint calculations. The nominal setpoints are selected to ensure that the setpoints do not exceed the Allowable Value between CHANNEL CALIBRATIONS. Operation with a trip setpoint less

(continued)

BASES

LCO
(continued)

conservative than the nominal trip setpoint, but within its Allowable Value, is acceptable. A channel is inoperable if its actual trip setpoint is not within its required Allowable Value. Trip setpoints are those predetermined values of output at which an action should take place. The setpoints are compared to the actual process parameter (e.g., overvoltage), and when the measured output value of the process parameter exceeds the setpoint, the associated device (e.g., trip unit) changes state. The analytic limits are derived from the limiting values of the process parameters obtained from the safety analysis.

The Allowable Values are derived from the analytic limits, corrected for calibration, process, and some of the instrument errors. The trip setpoints are then determined, accounting for the remaining instrument errors (e.g., drift). The trip setpoints derived in this manner provide adequate protection because instrumentation uncertainties, process effects, calibration tolerances, instrument drift, and severe environment errors (for channels that must function in harsh environments as defined by 10 CFR 50.49) are accounted for.

1
RPS component testing with

1
coil

1
Insert L.O.

1

The Allowable Values for the instrument settings are based on the RPS providing ≥ 57 Hz, $120\text{ V} \pm 10\%$ (to all equipment), and $115\text{ V} \pm 10\%$ (to scram and MSIV solenoids). The most limiting voltage requirement and associated line losses determine the settings of the electric power monitoring instrument channels. The settings are calculated based on the loads on the buses and RPS MG set or alternate power supply being 120 VAC and 60 Hz.

56 Hz $\pm 1\%$,
126.5V $\pm 2.5\%$,
and 108.0V $\pm 2.5\%$

APPLICABILITY

inservice
3

The operation of the RPS electric power monitoring assemblies is essential to disconnect the RPS bus powered components from the MG set or alternate power supply during abnormal voltage or frequency conditions. Since the degradation of a nonclass 1E source supplying power to the RPS bus can occur as a result of any random single failure, the OPERABILITY of the RPS electric power monitoring assemblies is required when the RPS bus powered components are required to be OPERABLE. This results in the RPS Electric Power Monitoring System OPERABILITY being required in MODES 1, 2, and 3, and in MODES 4 and 5 with any control rod withdrawn from a core cell containing one or more fuel assemblies or with both residual heat removal (RHR) shutdown cooling isolation valves open.

4

(continued)

1 Insert LCO

The trip setpoints are determined from the analytic limits, corrected for defined process, calibration, and instrument errors. The Allowable Values are then determined, based on the trip setpoint values, by accounting for the calibration based errors. These calibration based errors are limited to reference accuracy, instrument drift, errors associated with measurement and test equipment, and calibration tolerance of loop components. The trip setpoints and Allowable Values determined in this manner provide adequate protection because instrument uncertainties, process effects, calibration tolerances, instrument drift, and severe environment errors (for channels that must function in harsh environments as defined by 10 CFR 50.49) are accounted for and appropriately applied for the instrumentation.

BASES (continued)

ACTIONS

A.1

If one RPS electric power monitoring assembly for an inservice power supply (MG set or alternate) is inoperable, or one RPS electric power monitoring assembly on each inservice power supply is inoperable, the OPERABLE assembly will still provide protection to the RPS bus powered components under degraded voltage or frequency conditions. However, the reliability and redundancy of the RPS Electric Power Monitoring System is reduced, and only a limited time (72 hours) is allowed to restore the inoperable assembly to OPERABLE status. If the inoperable assembly cannot be restored to OPERABLE status, the associated power supply(s) must be removed from service (Required Action A.1). This places the RPS bus in a safe condition. An alternate power supply with OPERABLE power ~~ing~~ monitoring assemblies may then be used to power the RPS bus. 2

The 72 hour Completion Time takes into account the remaining OPERABLE electric power monitoring assembly and the low probability of an event requiring RPS electric power monitoring protection occurring during this period. It allows time for plant operations personnel to take corrective actions or to place the plant in the required condition in an orderly manner and without challenging plant systems.

Alternately, if it is not desired to remove the power supply from service (e.g., as in the case where removing the power supply(s) from service would result in a scram ~~or~~ (isolation)), Condition C or D, as applicable, must be entered and its Required Actions taken. 4

B.1

If both power monitoring assemblies for an inservice power supply (MG set or alternate) are inoperable or both power monitoring assemblies in each inservice power supply are inoperable, the system protective function is lost. In this condition, 1 hour is allowed to restore one assembly to OPERABLE status for each inservice power supply. If one inoperable assembly for each inservice power supply cannot be restored to OPERABLE status, the associated power supply(s) must be removed from service within 1 hour (Required Action B.1). An alternate power supply with

(continued)

BASES

ACTIONS

B.1 (continued)

OPERABLE assemblies may then be used to power one RPS bus. The 1 hour Completion Time is sufficient for the plant operations personnel to take corrective actions and is acceptable because it minimizes risk while allowing time for restoration or removal from service of the electric power monitoring assemblies.

Alternately, if it is not desired to remove the power supply(s) from service (e.g., as in the case where removing the power supply(s) from service would result in a scram ~~(or Isolation)~~), Condition C or D, as applicable, must be entered and its Required Actions taken.

C.1 and C.2

If any Required Action and associated Completion Time of Condition A or B are not met in MODE 1, 2, or 3, a plant shutdown must be performed. This places the plant in a condition where minimal equipment, powered through the inoperable RPS electric power monitoring assembly(s), is required and ensures that the safety function of the RPS (e.g., scram of control rods) is not required. The plant shutdown is accomplished by placing the plant in MODE 3 within 12 hours and in MODE 4 within 36 hours. The allowed Completion Time ~~(APB)~~ is reasonable, based on operating experience, to reach the required plant conditions from full power conditions in an orderly manner and without challenging plant systems.

D.1, D.2.1, and D.2.2

If any Required Action and associated Completion Time of Condition A or B are not met in MODE 4 or 5, with any control rod withdrawn from a core cell containing one or more fuel assemblies ~~(or with both RHR shutdown cooling valves open)~~, the operator must immediately initiate action to fully insert all insertable control rods in core cells containing one or more fuel assemblies. Required Action D.1 results in the least reactive condition for the reactor core and ensures that the safety function of the RPS (e.g., scram of control rods) is not required.

(continued)

BASES

ACTIONS

D.1. D.2.1. and D.2.2 (continued)

4

In addition, action must be immediately initiated to either restore one electric power monitoring assembly to OPERABLE status for the inservice power source supplying the required instrumentation powered from the RPS bus (Required Action D.2.1) or to isolate the RHR Shutdown Cooling System (Required Action D.2.2). Required Action B.2.1 is provided because the RHR Shutdown Cooling System may be needed to provide core cooling. All actions must continue until the applicable Required Actions are completed.

SURVEILLANCE
REQUIREMENTS

SR 3.3.8.2.1

3

A CHANNEL FUNCTIONAL TEST is performed on each overvoltage, undervoltage, and underfrequency channel to ensure that the entire channel will perform the intended function. Any setpoint adjustment shall be consistent with the assumptions of the current plant specific setpoint methodology.

As noted in the Surveillance, the CHANNEL FUNCTIONAL TEST is only required to be performed while the plant is in a condition in which the loss of the RPS bus will not jeopardize steady state power operation (the design of the system is such that the power source must be removed from service to conduct the Surveillance). The 24 hours is intended to indicate an outage of sufficient duration to allow for scheduling and proper performance of the Surveillance.

The 184 day Frequency and the Note in the Surveillance are based on guidance provided in Generic Letter 91-09 (Ref. 2).

SR 3.3.8.2.2

CHANNEL CALIBRATION is a complete check of the instrument loop and the sensor. This test verifies that the channel responds to the measured parameter within the necessary range and accuracy. CHANNEL CALIBRATION leaves the channel adjusted to account for instrument drifts between successive calibrations consistent with the plant specific setpoint methodology.

(continued)

BASES

SURVEILLANCE REQUIREMENTS

SR 3.3.8.2.2 (continued)

The Frequency is based on the assumption of a ⁽²⁴⁾18 month calibration interval in the determination of the magnitude of equipment drift in the setpoint analysis.

4

SR 3.3.8.2.3

Performance of a system functional test demonstrates that, with a required system actuation (simulated or actual) signal, the logic of the system will automatically trip open the associated power monitoring assembly. Only one signal per power monitoring assembly is required to be tested. This Surveillance overlaps with the CHANNEL CALIBRATION to provide complete testing of the safety function. The system functional test of the Class 1E circuit breakers is included as part of this test to provide complete testing of the safety function. If the breakers are incapable of operating, the associated electric power monitoring assembly would be inoperable.

1
The system functional test shall include actuation of the protective relays, tripping logic, and output circuit breakers.

The ⁽²⁴⁾18 month Frequency is based on the need to perform this Surveillance under the conditions that apply during a plant outage and the potential for an unplanned transient if the Surveillance were performed with the reactor at power. Operating experience has shown that these components usually pass the Surveillance when performed at the 18 month Frequency.

4

24

4

1 REFERENCES

1. FSAR, Section ^(u)7.2.2 (B.3/1.1/4.B)
2. NRC Generic Letter 91-09, "Modification of Surveillance Interval for the Electrical Protective Assemblies in Power Supplies for the Reactor Protection System"

5

2

JUSTIFICATION FOR DEVIATIONS FROM NUREG-1433, REVISION 1
ITS BASES: 3.3.8.2 - RPS ELECTRICAL POWER MONITORING

1. Changes have been made (additions, deletions, and/or changes to the NUREG) to reflect the plant specific methodology, nomenclature, number reference, system description, analysis description, or licensing basis description.
2. Typographical error corrected.
3. Editorial change made for enhanced clarity or to be consistent with similar statements in other places in the Bases.
4. Changes have been made to reflect those changes made to the Specification.
5. The brackets have been removed and the proper plant specific information/value has been provided.

**GENERIC NO SIGNIFICANT HAZARDS CONSIDERATION
ITS: SECTION 3.3 - INSTRUMENTATION**

**ADMINISTRATIVE CHANGES
("A.x" Labeled Comments/Discussions)**

In accordance with the criteria set forth in 10 CFR 50.92, ComEd has evaluated this proposed Technical Specifications change and determined it does not represent a significant hazards consideration. The following is provided in support of this conclusion.

1. Does the change involve a significant increase in the probability or consequences of an accident previously evaluated?

The proposed change involves reformatting, renumbering, and rewording the existing Technical Specifications. The reformatting, renumbering, and rewording process involves no technical changes to the existing Technical Specifications. As such, this change is administrative in nature and does not impact initiators of analyzed events or assumed mitigation of accident or transient events. Therefore, this change does not involve a significant increase in the probability or consequences of an accident previously evaluated.

2. Does the change create the possibility of a new or different kind of accident from any accident previously evaluated?

The proposed change does not involve a physical alteration of the plant (no new or different type of equipment will be installed) or changes in methods governing normal plant operation. The proposed change will not impose any new or eliminate any old requirements. Thus, this change does not create the possibility of a new or different kind of accident from any accident previously evaluated.

3. Does this change involve a significant reduction in a margin of safety?

The proposed change will not reduce a margin of safety because it has no impact on any safety analyses assumptions. This change is administrative in nature. Therefore, the change does not involve a significant reduction in a margin of safety.

GENERIC NO SIGNIFICANT HAZARDS CONSIDERATION
ITS: SECTION 3.3 - INSTRUMENTATION

RELOCATED SPECIFICATIONS
("R.x" Labeled Comments/Discussions)

In accordance with the criteria set forth in 10 CFR 50.92, ComEd has evaluated this proposed Technical Specifications change and determined it does not represent a significant hazards consideration. The following is provided in support of this conclusion.

1. Does the change involve a significant increase in the probability or consequences of an accident previously evaluated?

The proposed change relocates requirements and surveillances for structures, systems, components or variables that do not meet the criteria for inclusion in Technical Specifications as identified in the Application of Selection Criteria to the Quad Cities 1 and 2 Technical Specifications. The affected structures, systems, components or variables are not assumed to be initiators of analyzed events and are not assumed to mitigate accident or transient events. The requirements and surveillances for these affected structures, systems, components or variables will be relocated from the Technical Specifications to an appropriate administratively controlled document which will be maintained pursuant to 10 CFR 50.59. In addition, the affected structures, systems, components or variables are addressed in existing surveillance procedures which are also controlled by 10 CFR 50.59 and subject to the change control provisions imposed by plant administrative procedures, which endorse applicable regulations and standards. Therefore, this change does not involve a significant increase in the probability or consequences of an accident previously evaluated.

2. Does the change create the possibility of a new or different kind of accident from any accident previously evaluated.

The proposed change does not involve a physical alteration of the plant (no new or different type of equipment will be installed) or a change in the methods governing normal plant operation. The proposed change will not impose or eliminate any requirements and adequate control of existing requirements will be maintained. Thus, this change does not create the possibility of a new or different kind of accident from any accident previously evaluated.

3. Does this change involve a significant reduction in a margin of safety?

The proposed change will not reduce a margin of safety because it has no impact on any safety analysis assumptions. In addition, the relocated requirements and surveillances for the affected structure, system, component or variable remain the same as the existing Technical Specifications. Since any future changes to these requirements or the surveillance procedures will be evaluated per the requirements of 10 CFR 50.59, no reduction in a margin of safety will be permitted.

GENERIC NO SIGNIFICANT HAZARDS CONSIDERATION
ITS: SECTION 3.3 - INSTRUMENTATION

RELOCATED SPECIFICATIONS
("R.x" Labeled Comments/Discussions)

3. (continued)

The existing requirement for NRC review and approval of revisions, in accordance with 10 CFR 50.92, to these details proposed for relocation does not have a specific margin of safety upon which to evaluate. However, since the proposed change is consistent with the BWR Standard Technical Specification, NUREG-1433, Rev. 1, approved by the NRC Staff, revising the Technical Specifications to reflect the approved level of detail ensures no significant reduction in the margin of safety.

GENERIC NO SIGNIFICANT HAZARDS CONSIDERATION
ITS: SECTION 3.3 - INSTRUMENTATION

TECHNICAL CHANGES - MORE RESTRICTIVE
("M.x" Labeled Comments/Discussions)

In accordance with the criteria set forth in 10 CFR 50.92, ComEd has evaluated this proposed Technical Specifications change and determined it does not represent a significant hazards consideration. The following is provided in support of this conclusion.

1. Does the change involve a significant increase in the probability or consequences of an accident previously evaluated?

The proposed change provides more stringent requirements for operation of the facility. These more stringent requirements do not result in operation that will increase the probability of initiating an analyzed event and do not alter assumptions relative to mitigation of an accident or transient event. The more restrictive requirements continue to ensure process variables, structures, systems, and components are maintained consistent with the safety analyses and licensing basis. Therefore, this change does not involve a significant increase in the probability or consequences of an accident previously evaluated.

2. Does the change create the possibility of a new or different kind of accident from any accident previously evaluated?

The proposed change does not involve a physical alteration of the plant (no new or different type of equipment will be installed) or changes in the methods governing normal plant operation. The proposed change does impose different requirements. However, these changes are consistent with the assumptions in the safety analyses and licensing basis. Thus, this change does not create the possibility of a new or different kind of accident from any accident previously evaluated.

3. Does this change involve a significant reduction in a margin of safety?

The imposition of more restrictive requirements either has no impact on or increases the margin of plant safety. As provided in the discussion of the change, each change in this category is by definition, providing additional restrictions to enhance plant safety. The change maintains requirements within the safety analyses and licensing basis. Therefore, this change does not involve a significant reduction in a margin of safety.

GENERIC NO SIGNIFICANT HAZARDS CONSIDERATION
ITS: SECTION 3.3 - INSTRUMENTATION

**"GENERIC" LESS RESTRICTIVE CHANGES:
RELOCATING DETAILS TO TECHNICAL SPECIFICATION BASES, UFSAR, TRM, OR
OTHER PLANT CONTROLLED DOCUMENTS
("LA.x" Labeled Comments/Discussions)**

In accordance with the criteria set forth in 10 CFR 50.92, ComEd has evaluated this proposed Technical Specifications change and determined it does not represent a significant hazards consideration. The following is provided in support of this conclusion.

1. Does the change involve a significant increase in the probability or consequences of an accident previously evaluated?

The proposed change relocates certain details from the Technical Specifications to the Bases, UFSAR, TRM, or other plant controlled documents. The Bases, UFSAR, TRM, and other plant controlled documents containing the relocated information will be maintained in accordance with 10 CFR 50.59. In addition to 10 CFR 50.59 provisions, the Technical Specification Bases are subject to the change control provisions in the Administrative Controls Chapter of the ITS. The UFSAR is subject to the change control provisions of 10 CFR 50.71(e), and the plant procedures and other plant controlled documents are subject to controls imposed by plant administrative procedures, which endorse applicable regulations and standards. Since any changes to the Bases, UFSAR, TRM, or other plant controlled documents will be evaluated per the requirements of the Bases Control Program in Chapter 5.0 of the ITS or 10 CFR 50.59, no increase (significant or insignificant) in the probability or consequences of an accident previously evaluated will be allowed. Therefore, this change does not involve a significant increase in the probability or consequences of an accident previously evaluated.

2. Does the change create the possibility of a new or different kind of accident from any accident previously evaluated?

The proposed change does not involve a physical alteration of the plant (no new or different type of equipment will be installed) or a change in the methods governing normal plant operation. The proposed change will not impose or eliminate any requirements, and adequate control of the information will be maintained. Thus, this change does not create the possibility of a new or different kind of accident from any accident previously evaluated.

3. Does this change involve a significant reduction in a margin of safety?

The proposed change will not reduce a margin of safety because it has no impact on any safety analysis assumptions. In addition, the details to be transposed from the Technical Specifications to the Bases, UFSAR, TRM, or other plant controlled

GENERIC NO SIGNIFICANT HAZARDS CONSIDERATION
ITS: SECTION 3.3 - INSTRUMENTATION

"GENERIC" LESS RESTRICTIVE CHANGES:
RELOCATING DETAILS TO TECHNICAL SPECIFICATION BASES, UFSAR, TRM, OR
OTHER PLANT CONTROLLED DOCUMENTS
("LA.x" Labeled Comments/Discussions)

3. (continued)

documents are the same as the existing Technical Specifications. Since any future changes to these details in the Bases, UFSAR, TRM, or other plant controlled documents will be evaluated per the requirements of 10 CFR 50.59, no reduction (significant or insignificant) in a margin of safety will be allowed. Based on 10 CFR 50.92, the existing requirement for NRC review and approval of revisions, to these details proposed for relocation, does not have a specific margin of safety upon which to evaluate. However, since the proposed change is consistent with the BWR ISTS, NUREG-1433, Rev. 1, approved by the NRC Staff, revising the Technical Specifications to reflect the approved level of detail ensures no significant reduction in the margin of safety.

GENERIC NO SIGNIFICANT HAZARDS CONSIDERATION
ITS: SECTION 3.3 - INSTRUMENTATION

**"GENERIC" LESS RESTRICTIVE CHANGES:
EXTENDING SURVEILLANCE FREQUENCIES FROM 18 MONTHS TO 24 MONTHS
FOR SURVEILLANCES OTHER THAN CHANNEL CALIBRATIONS
("LD.x" Labeled Comments/Discussions)**

In accordance with the criteria set forth in 10 CFR 50.92, ComEd has evaluated this proposed Technical Specifications change and determined it does not represent a significant hazards consideration. The following is provided in support of this conclusion.

1. Does the change involve a significant increase in the probability or consequences of an accident previously evaluated?

The proposed change involves a change in the surveillance testing intervals from 18 months to 24 months. The proposed change does not physically impact the plant nor does it impact any design or functional requirements of the associated systems. That is, the proposed change does not degrade the performance or increase the challenges of any safety systems assumed to function in the accident analysis. The proposed change does not impact the Surveillance Requirements themselves nor the way in which the Surveillances are performed. Additionally, the proposed change does not introduce any new accident initiators since no accidents previously evaluated have as their initiators anything related to the frequency of surveillance testing. The proposed change does not affect the availability of equipment or systems required to mitigate the consequences of an accident because of the availability of redundant systems or equipment and because other tests performed more frequently will identify potential equipment problems. Furthermore, an historical review of surveillance test results indicated that all failures identified were unique, non-repetitive, and not related to any time-based failure modes, and indicated no evidence of any failures that would invalidate the above conclusions. Therefore, the proposed change does not increase the probability or consequences of an accident previously evaluated.

2. Does the change create the possibility of a new or different kind of accident from any accident previously evaluated?

The proposed change involves a change in the surveillance testing intervals from 18 months to 24 months. The proposed change does not introduce any failure mechanisms of a different type than those previously evaluated since there are no physical changes being made to the facility. In addition, the Surveillance Requirements themselves and the way Surveillances are performed will remain unchanged. Furthermore, an historical review of surveillance test results indicated no evidence of any failures that would invalidate the above conclusions. Therefore, the proposed change does not create the possibility of a new or different kind of accident from any previously evaluated.

GENERIC NO SIGNIFICANT HAZARDS CONSIDERATION
ITS: SECTION 3.3 - INSTRUMENTATION

"GENERIC" LESS RESTRICTIVE CHANGES:
EXTENDING SURVEILLANCE FREQUENCIES FROM 18 MONTHS TO 24 MONTHS
FOR SURVEILLANCES OTHER THAN CHANNEL CALIBRATIONS
("LD.x" Labeled Comments/Discussions)

3. Does this change involve a significant reduction in a margin of safety?

Although the proposed change will result in an increase in the interval between surveillance tests, the impact on system availability is minimal based on other, more frequent testing or redundant systems or equipment, and there is no evidence of any failures that would impact the availability of the systems. Therefore, the assumptions in the licensing basis are not impacted, and the proposed change does not involve a significant reduction in a margin of safety.

GENERIC NO SIGNIFICANT HAZARDS CONSIDERATION
ITS: SECTION 3.3 - INSTRUMENTATION

**"GENERIC" LESS RESTRICTIVE CHANGES:
EXTENDING SURVEILLANCE FREQUENCIES FROM 18 MONTHS TO 24 MONTHS
FOR CHANNEL CALIBRATION SURVEILLANCES
("LE.x" Labeled Comments/Discussions)**

In accordance with the criteria set forth in 10 CFR 50.92, ComEd has evaluated this proposed Technical Specifications change and determined it does not represent a significant hazards consideration. The following is provided in support of this conclusion.

1. Does the change involve a significant increase in the probability or consequences of an accident previously evaluated?

The proposed change involves a change in the instrumentation channel calibration surveillance testing intervals from 18 months to 24 months. The proposed change does not physically impact the plant nor does it impact any design or functional requirements of the associated systems. That is, the proposed change does not degrade the performance or increase the challenges of any safety systems assumed to function in the accident analysis. The proposed change does not impact the Surveillance Requirements themselves nor the way in which the Surveillances are performed. Additionally, the proposed change does not introduce any new accident initiators since no accidents previously evaluated have as their initiators anything related to the frequency of surveillance testing. The proposed change does not affect the availability of equipment or systems required to mitigate the consequences of an accident because of the availability of redundant systems or equipment and because other test performed more frequently will identify potential equipment problems. Furthermore, an historical review of surveillance test results indicated that all failures identified were unique, non-repetitive, and not related to any time-based failure modes, and indicated no evidence of any failures that would invalidate the above conclusions. Therefore, the proposed change does not increase the probability or consequences of an accident previously evaluated.

2. Does the change create the possibility of a new or different kind of accident from any accident previously evaluated?

The proposed change involves a change in the instrumentation channel calibration surveillance testing intervals from 18 months to 24 months. The proposed change does not introduce any failure mechanisms of a different type than those previously evaluated since there are no physical changes being made to the facility. In addition, the Surveillance Requirements themselves and the way Surveillances are performed will remain unchanged. Furthermore, an historical review of surveillance test results indicated no evidence of any failures that would invalidate the above conclusions. Therefore, the proposed change does not create the possibility of a new or different kind of accident from any previously evaluated.

GENERIC NO SIGNIFICANT HAZARDS CONSIDERATION
ITS: SECTION 3.3 - INSTRUMENTATION

"GENERIC" LESS RESTRICTIVE CHANGES:
EXTENDING SURVEILLANCE FREQUENCIES FROM 18 MONTHS TO 24 MONTHS
FOR CHANNEL CALIBRATION SURVEILLANCES
("LE.x" Labeled Comments/Discussions) (continued)

3. Does this change involve a significant reduction in a margin of safety?

Although the proposed change will result in an increase in the interval between surveillance tests, the impact on system availability is minimal based on other, more frequent testing or redundant systems or equipment, and there is no evidence of any failures that would impact the availability of the systems. Therefore, the assumptions in the licensing basis are not impacted, and the proposed change does not involve a significant reduction in a margin of safety.

GENERIC NO SIGNIFICANT HAZARDS CONSIDERATION
ITS: SECTION 3.3 - INSTRUMENTATION

GENERIC LESS RESTRICTIVE CHANGES:
CHANGING INSTRUMENTATION ALLOWABLE VALUES
("LF.x" Labeled Comments/Discussions)

In accordance with the criteria set forth in 10 CFR 50.92, ComEd has evaluated this proposed Technical Specifications change and determined it does not represent a significant hazards consideration. The following is provided in support of this conclusion.

1. Does the change involve a significant increase in the probability or consequences of an accident previously evaluated?

The proposed changes in selected Allowable Values for the instrumentation included in proposed Section 3.3 of the Technical Specifications are the result of application of the ComEd Instrumentation Setpoint Methodology. This methodology incorporates the guidance of ANSI/ISA S67.04-Part I-1994 and RP67.04-Part II-1994. Application of this methodology results in instrumentation selected Allowable Values which more accurately reflect total instrumentation loop accuracy as well as that of test equipment and setpoint drift between Surveillances. The proposed changes will not result in any hardware changes. The instrumentation included in proposed Section 3.3 of the Technical Specifications is not assumed to be an initiator of any analyzed event. Existing operating margin between plant conditions and actual plant setpoints is not significantly reduced due to this change. As a result, the proposed changes will not result in unnecessary plant transients.

The role of the proposed Section 3.3 instrumentation is in mitigating and thereby limiting the consequences of accidents. The Allowable Values have been developed to ensure that the design and safety analysis limits will be satisfied. The methodology used for the development of the Allowable Values ensures the affected instrumentation remains capable of mitigating design basis events as described in the safety analyses and that the results and consequences described in the safety analyses remain bounding. Additionally, the proposed change does not alter the plant's ability to detect and mitigate events. Therefore, this change does not involve a significant increase in the probability or consequences of an accident previously evaluated.

2. Does the change create the possibility of a new or different kind of accident from any accident previously evaluated?

The proposed changes are the result of application of the Instrumentation Setpoint Methodology and do not create the possibility of a new or different kind of accident from any accident previously evaluated. This is based on the fact that the method and manner of plant operation is unchanged. The use of the proposed Allowable Values does not impact safe operation of the plant, in that, the safety analysis limits will be

GENERIC NO SIGNIFICANT HAZARDS CONSIDERATION
ITS: SECTION 3.3 - INSTRUMENTATION

GENERIC LESS RESTRICTIVE CHANGES:
CHANGING INSTRUMENTATION ALLOWABLE VALUES
("LF.x" Labeled Comments/Discussions)

2. (continued)

maintained. The proposed Allowable Values involve no system additions or physical modifications to plant systems. These Allowable Values were developed using a methodology to ensure the affected instrumentation remains capable of mitigating accidents and transients. Plant equipment will not be operated in a manner different from previous operation, except that setpoints may be changed. Since operational methods remain unchanged and the operating parameters have been evaluated to maintain the station within existing design basis criteria, no different type of failure or accident is created.

3. Does this change involve a significant reduction in a margin of safety?

The proposed change does not involve a reduction in a margin of safety. The proposed changes have been developed using a methodology to ensure safety analysis limits are not exceeded. As such, this proposed change does not involve a significant reduction in a margin of safety.

**NO SIGNIFICANT HAZARDS CONSIDERATION
ITS: 3.3.1.1 - RPS INSTRUMENTATION**

L.1 CHANGE

In accordance with the criteria set forth in 10 CFR 50.92, ComEd has evaluated this proposed Technical Specifications change and determined it does not represent a significant hazards consideration. The following is provided in support of this conclusion.

1. Does the change involve a significant increase in the probability or consequences of an accident previously evaluated?

The proposed change excludes neutron detectors from the RPS RESPONSE TIME Surveillance Requirements. The probability of an accident is not increased by these changes because the proposed change does not involve any physical changes to plant systems, structures, or components (SSC), or the manner in which these SSC are operated, maintained, or modified. The consequences of an accident will not be increased because the change will not affect the ability of the Local Power Range Monitor strings, the Average Power Range Monitors, and Intermediate Range Monitors to respond to core conditions. The neutron detectors of the APRMs are excluded from the Channel Calibrations and Response Time tests because they are passive devices, with minimal drift, and because of the difficulty of simulating a meaningful signal. Changes in neutron detector sensitivity are compensated for by performance of the 7 day calorimetric calibration (SR 3.3.1.1.2) and the LPRM calibration against the TIPs (SR 3.3.1.1.9). This allowance is also acceptable because the principles of detector operation virtually ensure an instantaneous response time for all neutron detectors. Therefore, this change will not involve a significant increase in the probability or consequences of an accident previously evaluated.

2. Does the change create the possibility of a new or different kind of accident from any accident previously evaluated?

This proposed change will not involve any physical changes to plant systems, structures, or components (SSCs), or the manner in which these SSCs are operated, maintained, modified, or inspected. The proposed change still provides adequate assurance the neutron detectors remain capable of performing their function. Therefore, this change will not create the possibility of a new or different kind of accident from any accident previously evaluated.

3. Does this change involve a significant reduction in a margin of safety?

The proposed change excludes neutron detectors from the Response Time Surveillance Requirements. The proposed change does not involve a significant reduction in a margin of safety because the change will not affect the ability of the Local Power Range Monitor strings, the Average Power Range Monitors, or Intermediate Range Monitors

NO SIGNIFICANT HAZARDS CONSIDERATION
ITS: 3.3.1.1 - RPS INSTRUMENTATION

L.1 CHANGE

3. (continued)

to detect and respond to core conditions. The neutron detectors are excluded from the Response Time Tests because they are passive devices, with minimal drift, and because of the difficulty of simulating a meaningful signal. Changes in neutron detector sensitivity are compensated for by performance of the 7 day calorimetric calibration (SR 3.3.1.1.2) and the LPRM calibration against the TIPs (SR 3.3.1.1.9). This allowance is also acceptable because the principles of detector operation virtually ensure an instantaneous response time for all neutron detectors. As a result, the change does not affect the current analysis assumptions and adequate assurance is provided that the neutron detectors will be maintained Operable. Therefore, this change does not involve a significant reduction in a margin of safety.

NO SIGNIFICANT HAZARDS CONSIDERATION
ITS: 3.3.1.1 - RPS INSTRUMENTATION

L.2 CHANGE

In accordance with the criteria set forth in 10 CFR 50.92, ComEd has evaluated this proposed Technical Specifications change and determined it does not represent a significant hazards consideration. The following is provided in support of this conclusion.

1. Does the change involve a significant increase in the probability or consequences of an accident previously evaluated?

This change will remove normal operation requirements for OPERABILITY of the IRM, APRM, Reactor Mode Switch Shutdown Position, and Manual Scram RPS Functions in MODES 3 and 4. Control rod withdrawal is not allowed in these conditions and the RPS scram function serves no purpose. These RPS Functions are not considered as initiators for any accidents previously analyzed. Therefore, this change does not significantly increase the probability of a previously analyzed accident. Further, this change does not impact the capability of the system to perform its required function since the control rods are already inserted. Therefore, this change does not significantly increase the consequences of a previously analyzed accident.

2. Does the change create the possibility of a new or different kind of accident from any accident previously evaluated?

The proposed change does not introduce a new mode of plant operation and does not involve physical modification to the plant. Therefore, it does not create the possibility of a new or different kind of accident from any accident previously evaluated.

3. Does this change involve a significant reduction in a margin of safety?

This change does not involve a significant reduction in a margin of safety since other requirements prevent the withdrawal of control rods in these modes, thus making the RPS scram Functions unnecessary.

NO SIGNIFICANT HAZARDS CONSIDERATION
ITS: 3.3.1.1 - RPS INSTRUMENTATION

L.3 CHANGE

In accordance with the criteria set forth in 10 CFR 50.92, ComEd has evaluated this proposed Technical Specifications change and determined it does not represent a significant hazards consideration. The following is provided in support of this conclusion.

1. Does the change involve a significant increase in the probability or consequences of an accident previously evaluated?

This change will remove requirements for OPERABILITY of the IRM, Reactor Mode Switch Shutdown Position, and Manual Scram RPS Functions in MODE 5 with no control rods withdrawn from fueled core cells. Control rods are fully inserted in these conditions and the RPS scram function serves no purpose. These RPS Functions are not considered as initiators for any accidents previously analyzed. Therefore, this change does not significantly increase the probability of a previously analyzed accident. Further, this change does not impact the capability of the system to perform its required function since all control rods in core cells with fuel assemblies are inserted. Therefore, this change does not significantly increase the consequences of a previously analyzed accident.

2. Does the change create the possibility of a new or different kind of accident from any accident previously evaluated?

The proposed change does not introduce a new mode of plant operation and does not involve physical modification to the plant. Therefore, it does not create the possibility of a new or different kind of accident from any accident previously evaluated.

3. Does this change involve a significant reduction in a margin of safety?

This change does not involve a significant reduction in a margin of safety since other requirements control the withdrawal of control rods in these modes, thus making the RPS scram Functions unnecessary.

NO SIGNIFICANT HAZARDS CONSIDERATION
ITS: 3.3.1.1 - RPS INSTRUMENTATION

L.4 CHANGE

In accordance with the criteria set forth in 10 CFR 50.92, ComEd has evaluated this proposed Technical Specifications change and determined it does not represent a significant hazards consideration. The following is provided in support of this conclusion.

1. Does the change involve a significant increase in the probability or consequences of an accident previously evaluated?

This change will remove requirements for OPERABILITY of the Scram Discharge Volume Water Level—High RPS Function in MODE 5 unless a control rod is withdrawn from a core cell containing fuel assemblies. Control rod withdrawal from or insertion into core cells without fuel assemblies does not significantly affect core reactivity and therefore, the RPS scram function serves no purpose. The affected RPS Function is not considered as an initiator for any accidents previously analyzed. Therefore, this change does not significantly increase the probability of a previously analyzed accident. Further, this change does not impact the capability of the system to perform its required function, i.e., insert withdrawn control rods, since all control rods in core cells with fuel assemblies are already inserted. Therefore, this change does not significantly increase the consequences of a previously analyzed accident.

2. Does the change create the possibility of a new or different kind of accident from any accident previously evaluated?

The proposed change does not introduce a new mode of plant operation and does not involve physical modification to the plant. Therefore, it does not create the possibility of a new or different kind of accident from any accident previously evaluated.

3. Does this change involve a significant reduction in a margin of safety?

This change does not involve a significant reduction in a margin of safety since the requirements continue to provide OPERABILITY of the Scram Discharge Volume Water Level—High RPS Function under all of the conditions in which it may be required.

NO SIGNIFICANT HAZARDS CONSIDERATION
ITS: 3.3.1.1 - RPS INSTRUMENTATION

L.5 CHANGE

In accordance with the criteria set forth in 10 CFR 50.92, ComEd has evaluated this proposed Technical Specifications change and determined it does not represent a significant hazards consideration. The following is provided in support of this conclusion.

1. Does the change involve a significant increase in the probability or consequences of an accident previously evaluated?

This change deletes the requirement in CTS Table 3.1.A-1 Action 13 and 19 to suspend LPRM replacement if SRM instrumentation is not OPERABLE per CTS 3.10.B concurrent with the RPS Functions required to be Operable in MODE 5. The proposed requirements are adequate to minimize the reactivity of the core whenever SRM or other RPS Functions are inoperable in MODE 5. The current requirements impose restrictions (repair the SRMs prior to repairing the LPRMs) that are not necessary. Since the proposed Specifications adequately reduce the core reactivity when necessary, this change is acceptable. The RPS Functions and SRMs are not considered as initiators for any accidents previously analyzed. Therefore, this change does not significantly increase the probability of a previously analyzed accident. Further, this change does not impact the capability of the system to perform its required function since the control rods will be required to be inserted immediately. Therefore, this change does not significantly increase the consequences of a previously analyzed accident.

2. Does the change create the possibility of a new or different kind of accident from any accident previously evaluated?

The proposed change does not introduce a new mode of plant operation and does not involve physical modification to the plant. Therefore, it does not create the possibility of a new or different kind of accident from any accident previously evaluated.

3. Does the change involve a significant reduction in a margin of safety?

This change does not involve a significant reduction in a margin of safety since other requirements will minimize the reactivity of the core when RPS Functions or SRMs are inoperable, thus making the RPS scram Functions and SRM indication unnecessary.

NO SIGNIFICANT HAZARDS CONSIDERATION
ITS: 3.3.1.1 - RPS INSTRUMENTATION

L.6 CHANGE

In accordance with the criteria set forth in 10 CFR 50.92, ComEd has evaluated this proposed Technical Specifications change and determined it does not represent a significant hazards consideration. The following is provided in support of this conclusion.

1. Does the change involve a significant increase in the probability or consequences of an accident previously evaluated?

The RPS Instrumentation is not assumed to be an initiator of any analyzed event. The change will not allow continuous operation such that a single failure will preclude the affected RPS Function from being performed. This change deletes the requirement to initiate a power reduction within 15 minutes when a channel is inoperable greater than the allowed outage time. The requirement to reduce power to below 45% RTP (the power at which the RPS Functions are no longer applicable) is unchanged. Deletion of the 15 minute requirement provides time to perform an orderly reduction in power in a controlled manner. The consequences of an accident are unchanged, since this change does not affect the time to reach 45% RTP. Therefore, the proposed change does not involve a significant increase in the probability or consequences of an accident previously evaluated.

2. Does the change create the possibility of a new or different kind of accident from any accident previously evaluated?

The possibility of a new or different kind of accident from any accident previously evaluated is not created because the proposed change does not introduce a new mode of plant operation and does not involve physical modification to the plant.

3. Does this change involve a significant reduction in a margin of safety?

No reduction in a margin of safety is involved since this change does not affect the time allowed for operation with the RPS channels inoperable. Additionally, the 15 minute action initiation time is not an assumption of a design basis accident or transient analysis.

NO SIGNIFICANT HAZARDS CONSIDERATION
ITS: 3.3.1.1 - RPS INSTRUMENTATION

L.7 CHANGE

In accordance with the criteria set forth in 10 CFR 50.92, ComEd has evaluated this proposed Technical Specifications change and determined it does not represent a significant hazards consideration. The following is provided in support of this conclusion.

1. Does the change involve a significant increase in the probability or consequences of an accident previously evaluated?

The APRM RPS instrumentation is not assumed in the initiation of any analyzed event. The role of this instrumentation is in mitigating and, thereby, limiting the consequences of analyzed events. The proposed change effectively extends the initial Surveillance Frequency until 12 hours after THERMAL POWER is $\geq 25\%$ RTP regardless of the status of the APRMs. This allows time after the appropriate conditions are established to perform the Surveillance. The requirement to calibrate within 2 and 12 hours depending on the status of the APRMS has been included in proposed Note 2 to ITS 3.3.1.1 ACTIONS. The proposed time of 12 hours after THERMAL POWER is $\geq 25\%$ RTP is allowed because it is difficult to accurately determine core THERMAL POWER from a heat balance $< 25\%$ RTP. The 12 hours provides sufficient time to perform the Surveillance after THERMAL POWER $\geq 25\%$. This is acceptable since at these low power levels, there is adequate margin to thermal limits (MCPR, APLGHR, LHGR). As a result, the consequences of an accident are not affected by this change. This change will not alter assumptions relative to the mitigation of an accident or transient event. Therefore, these changes will not involve a significant increase in the probability or consequences of an accident previously evaluated.

2. Does the change create the possibility of a new or different kind of accident from any accident previously evaluated?

The proposed change does not introduce a new mode of plant operation and does not involve physical modification to the plant. Therefore, this change will not create the possibility of a new or different kind of accident from any accident previously evaluated.

3. Does this change involve a significant reduction in a margin of safety?

The margin of safety is not reduced by this change since the proposed change to the Surveillance Frequency provides the necessary assurance that the APRM instrumentation has been accurately calibrated at an early opportunity. This change

NO SIGNIFICANT HAZARDS CONSIDERATION
ITS: 3.3.1.1 - RPS INSTRUMENTATION

L.7 CHANGE

3. (continued)

extends the initial performance of the Surveillance Requirement to within 12 hours after reaching 25% RTP regardless of the status of the APRMs. The requirement to calibrate within 2 and 12 hours depending on the status of the APRMS has been included in proposed Note 2 to ITS 3.3.1.1 ACTIONS. The proposed time of 12 hours after THERMAL POWER is $\geq 25\%$ RTP is allowed because it is difficult to accurately determine core THERMAL POWER from a heat balance $< 25\%$ RTP. The 12 hours provides sufficient time to perform the Surveillance after THERMAL POWER $\geq 25\%$. This is acceptable since at these low power levels, there is adequate margin to thermal limits (MCPR, APLGHR, LHGR). In addition, this change provides the benefit of allowing the Surveillance to be postponed until appropriate plant conditions exist for performing the Surveillance accurately. The safety analysis assumptions will still be maintained, thus no question of safety exists. Therefore, this change does not involve a significant reduction in a margin of safety.

NO SIGNIFICANT HAZARDS CONSIDERATION
ITS: 3.3.1.1 - RPS INSTRUMENTATION

L.8 CHANGE

In accordance with the criteria set forth in 10 CFR 50.92, ComEd has evaluated this proposed Technical Specifications change and determined it does not represent a significant hazards consideration. The following is provided in support of this conclusion.

1. Does the change involve a significant increase in the probability or consequences of an accident previously evaluated?

The proposed change involves a change in the instrumentation channel calibration surveillance testing intervals from 6 months to 24 months for the recirculation flow portion of the APRM Flow Biased Neutron Flux—High channels. The proposed change does not physically impact the plant nor does it impact any design or functional requirements of the associated systems. That is, the proposed change does not degrade the performance or increase the challenges of any safety systems assumed to function in the accident analysis. The proposed change does not impact the Surveillance Requirements themselves nor the way in which the Surveillances are performed. Additionally, the proposed change does not introduce any new accident initiators since no accidents previously evaluated have as their initiators anything related to the frequency of surveillance testing. The proposed change does not affect the availability of equipment or systems required to mitigate the consequences of an accident because of the availability of redundant systems or equipment and because other tests performed more frequently will identify potential equipment problems. Therefore, the proposed change does not increase the probability or consequences of an accident previously evaluated.

2. Does the change create the possibility of a new or different kind of accident from any accident previously evaluated?

The proposed change involves a change in the instrumentation channel calibration surveillance testing intervals from 6 months to 24 months for the recirculation flow portion of the APRM Flow Biased Neutron Flux—High channels. The proposed change does not introduce any failure mechanisms of a different type than those previously evaluated since there are no physical changes being made to the facility. In addition, the Surveillance Requirements themselves and the way Surveillances are performed will remain unchanged. Therefore, the proposed change does not create the possibility of a new or different kind of accident from any previously evaluated.

NO SIGNIFICANT HAZARDS CONSIDERATION
ITS: 3.3.1.1 - RPS INSTRUMENTATION

L.8 CHANGE (continued)

3. Does this change involve a significant reduction in a margin of safety?

Although the proposed change will result in an increase in the interval between surveillance tests for the recirculation flow portion of the APRM Flow Biased Neutron Flux—High channels, the impact on system availability is small based on other, more frequent testing or redundant systems or equipment, and there is no evidence of any failures that would impact the availability of the systems. Therefore, the assumptions in the licensing basis are not impacted, and the proposed change does not involve a significant reduction in a margin of safety.

NO SIGNIFICANT HAZARDS CONSIDERATION
ITS: 3.3.1.1 - RPS INSTRUMENTATION

L.9 CHANGE

In accordance with the criteria set forth in 10 CFR 50.92, ComEd has evaluated this proposed Technical Specifications change and determined it does not represent a significant hazards consideration. The following is provided in support of this conclusion.

1. Does the change involve a significant increase in the probability or consequences of an accident previously evaluated?

The RPS Instrumentation is not assumed to be an initiator of any analyzed event. The change will not allow continuous operation such that a single failure will preclude the affected RPS Function from being performed. This change allows an additional 2 hours to reach 45% RTP, which provides a reasonable amount of time to perform an orderly decrease in power, thus further minimizing a potential upset from a too rapid decrease in plant power. Additionally, the consequences of an event occurring while the unit is decreasing power during the extra time is the same as the consequences of an event occurring for the current time. Therefore, the proposed change does not involve a significant increase in the probability or consequences of an accident previously evaluated.

2. Does the change create the possibility of a new or different kind of accident from any accident previously evaluated?

The possibility of a new or different kind of accident from any accident previously evaluated is not created because the proposed change does not introduce a new mode of plant operation and does not involve physical modification to the plant.

3. Does this change involve a significant reduction in a margin of safety?

The increased time allowed for reaching the applicable condition with inoperable RPS channels is acceptable based on the small probability of an event requiring the inoperable channels to function and the minimization of plant transients. The requested extension will provide sufficient time for the unit to reach the applicable condition in an orderly manner. As a result, the potential for human error will be reduced. As such, any reduction in a margin of safety will be insignificant and offset by the benefit gained from providing sufficient time to reach the applicable condition, thus avoiding potential plant transients from attempting to reach the applicable condition in the current time.

NO SIGNIFICANT HAZARDS CONSIDERATION
ITS: 3.3.1.1 - RPS INSTRUMENTATION

L.10 CHANGE

In accordance with the criteria set forth in 10 CFR 50.92, ComEd has evaluated this proposed Technical Specifications change and determined it does not represent a significant hazards consideration. The following is provided in support of this conclusion.

1. Does the change involve a significant increase in the probability or consequences of an accident previously evaluated?

The proposed change excludes RPS RESPONSE TIME testing for certain RPS Functions. The probability of an accident is not increased by this change because the proposed change does not involve any physical changes to plant systems, structures, or components (SSCs), or the manner in which these SSCs are operated, maintained, or modified. The consequences of an accident will not be increased because these Functions are not credited in any accident or transient analyses. The Functions excluded are the Manual Scram, Reactor Mode Switch, IRMs, APRM Neutron Flux Setdown, APRM INOP, and Scram Discharge Volume (SDV) Water Level. This change is acceptable since the OPERABILITY of the channels associated with these Functions will still be confirmed during the performance of a LOGIC SYSTEM FUNCTIONAL TEST, CHANNEL FUNCTIONAL TEST or CHANNEL CALIBRATION, as applicable. Therefore, this change will not involve a significant increase in the probability or consequences of an accident previously evaluated.

2. Does the change create the possibility of a new or different kind of accident from any accident previously evaluated?

This proposed change will not involve any physical changes to plant SSCs, or the manner in which these SSCs are operated, maintained, modified, or inspected. The proposed change still provides adequate assurance the RPS Functions remain capable of performing their function, as assumed in the safety analyses. Therefore, this change will not create the possibility of a new or different kind of accident from any accident previously evaluated.

3. Does this change involve a significant reduction in a margin of safety?

The proposed change excludes RPS RESPONSE TIME testing for certain RPS Functions. The proposed change does not involve a significant reduction in a margin of safety because these Functions are not credited in any accident or transient analyses. The Functions excluded are the Manual Scram, Reactor Mode Switch, IRMs, APRM

NO SIGNIFICANT HAZARDS CONSIDERATION
ITS: 3.3.1.1 - RPS INSTRUMENTATION

L.10 CHANGE

3. (continued)

Neutron Flux Setdown, APRM INOP, and Scram Discharge Volume (SDV) Water Level. This change is acceptable since the OPERABILITY of the channels associated with these Functions will still be confirmed during the performance of a LOGIC SYSTEM FUNCTIONAL TEST, CHANNEL FUNCTIONAL TEST or CHANNEL CALIBRATION, as applicable. The change does not affect the current analysis assumptions and adequate assurance is provided that the RPS Functions will be maintained Operable. Therefore, this change does not involve a significant reduction in a margin of safety.

NO SIGNIFICANT HAZARDS CONSIDERATION
ITS: 3.3.1.1 - RPS INSTRUMENTATION

L.11 CHANGE

In accordance with the criteria set forth in 10 CFR 50.92, ComEd has evaluated this proposed Technical Specifications change and determined it does not represent a significant hazards consideration. The following is provided in support of this conclusion.

1. Does the change involve a significant increase in the probability or consequences of an accident previously evaluated?

Reactor power is not considered as an initiator of any analyzed event. In addition, neither the failure to post a notice concerning the APRM gains, nor the APRM gains themselves are considered as an initiator of any analyzed event. While the initial power level is assumed as an initial condition of many accidents, this change will not affect the requirement to maintain power level within the assumptions of the accident analysis. The Quad Cities 1 and 2 Operating License will continue to require Quad Cities 1 and 2 to not exceed 100% of RTP. Therefore, the proposed change does not significantly increase the probability or consequences of a previously evaluated accident.

2. Does the change create the possibility of a new or different kind of accident from any accident previously evaluated?

The proposed change introduces no new mode of plant operation nor does it require physical modification to the plant. Therefore, the change does not create the possibility of a new or different kind of accident from any accident previously evaluated.

3. Does this change involve a significant reduction in a margin of safety?

This change has no impact on any safety analysis assumption since the requirement to maintain power less than or equal to 100% RTP, as specified in the Operating License, is unchanged. In addition, failure to post a notice that the APRM gains must be adjusted will not increase the potential for exceeding 100% RTP. Therefore, the change does not involve a significant reduction in a margin of safety.

NO SIGNIFICANT HAZARDS CONSIDERATION
ITS: 3.3.1.2 - SRM INSTRUMENTATION

L.1 CHANGE

In accordance with the criteria set forth in 10 CFR 50.92, ComEd has evaluated this proposed Technical Specifications change and determined it does not represent a significant hazards consideration. The following is provided in support of this conclusion.

1. Does the change involve a significant increase in the probability or consequences of an accident previously evaluated?

This change will allow short term continued operation with inoperable SRMs if the monitoring function capability is maintained, and short term continued operation with no OPERABLE channels if all positive reactivity changes due to control rod withdrawal are suspended. These instruments are not the initiator of any accidents previously evaluated. Therefore, this change does not significantly increase the probability of a previously analyzed accident. Further, this change does not further degrade the capability of the system to perform its required function under these circumstances. Therefore, this change does not significantly increase the consequences of a previously analyzed accident.

2. Does the change create the possibility of a new or different kind of accident from any accident previously evaluated?

The proposed change does not introduce a new mode of plant operation and does not involve physical modification to the plant. Therefore, it does not create the possibility of a new or different kind of accident from any accident previously evaluated.

3. Does this change involve a significant reduction in a margin of safety?

This change does not involve a significant reduction in a margin of safety since the required safety function capability or the Function will be maintained under the conditions during which it may be required.

NO SIGNIFICANT HAZARDS CONSIDERATION
ITS: 3.3.1.2 - SRM INSTRUMENTATION

L.2 CHANGE

In accordance with the criteria set forth in 10 CFR 50.92, ComEd has evaluated this proposed Technical Specifications change and determined it does not represent a significant hazards consideration. The following is provided in support of this conclusion.

1. Does the change involve a significant increase in the probability or consequences of an accident previously evaluated?

The requirement to "lock" the mode switch in the Shutdown position is not assumed in the initiation of any analyzed event. This requirement was specified in the Technical Specifications to ensure that the reactor mode switch was not inadvertently moved from the Shutdown position resulting in an unauthorized MODE change. However, adequate administrative controls exist as a result of ITS Table 1.1-1 and the requirements of ITS 3.0.4 to ensure the mode switch is maintained in the Shutdown position without the explicit requirement to "lock" the reactor mode switch in Shutdown. Reactor mode switch positions other than Shutdown result in the unit entering some other MODE; with the associated Technical Specification compliance requirements of that MODE and of ITS 3.0.4. As a result, the accident consequences are unaffected by this change. Therefore, this change will not involve a significant increase in the probability or consequences of an accident previously evaluated.

2. Does the change create the possibility of a new or different kind of accident from any accident previously evaluated?

The possibility of a new or different kind of accident from any accident previously evaluated is not created because the proposed change does not introduce a new mode of plant operation and does not involve physical modification to the plant.

3. Does this change involve a significant reduction in a margin of safety?

The requirement to "lock" the mode switch in the Shutdown position was specified in the Technical Specifications to ensure that the reactor mode switch was not inadvertently moved from the Shutdown position resulting in an unauthorized MODE change. However, adequate administrative controls exist as a result of ITS Table 1.1-1 and the requirements of ITS 3.0.4 to ensure the mode switch is maintained in the Shutdown position without the explicit requirement to "lock" the reactor mode switch in Shutdown. Reactor mode switch positions other than Shutdown result in the unit entering some other MODE; with the associated Technical Specification

- compliance requirements of that MODE and of ITS 3.0.4. Therefore, this change does not involve a significant reduction in a margin of safety.

NO SIGNIFICANT HAZARDS CONSIDERATION
ITS: 3.3.1.2 - SRM INSTRUMENTATION

L.3 CHANGE

In accordance with the criteria set forth in 10 CFR 50.92, ComEd has evaluated this proposed Technical Specifications change and determined it does not represent a significant hazards consideration. The following is provided in support of this conclusion.

1. Does the change involve a significant increase in the probability or consequences of an accident previously evaluated?

The proposed change would remove an unnecessary additional performance of a Surveillance which has been performed within its normally required Frequency. Not performing the Surveillance would not affect any equipment which is assumed to be an initiator of any analyzed event. Since the Surveillance continues to be performed on its normal Frequency, there is no impact on the capability of the system to perform its required safety function. Therefore, the proposed change does not involve a significant increase in the probability or consequences of an accident previously evaluated.

2. Does the change create the possibility of a new or different kind of accident from any accident previously evaluated?

The proposed change does not create the possibility of a new or different kind of accident from any accident previously evaluated because the proposed change does not introduce a new mode of plant operation and does not involve physical modification to the plant.

3. Does this change involve a significant reduction in a margin of safety?

The normal Surveillance Frequency has been shown, based on operating experience, to be adequate for assuring the equipment is available and capable of performing its intended function. Additionally, the requirements of proposed SR 3.0.4 (CTS 4.0.D) provide assurance the equipment is OPERABLE prior to entering the MODES for which it is required. Therefore, the proposed change does not involve a significant reduction in a margin of safety.

NO SIGNIFICANT HAZARDS CONSIDERATION
ITS: 3.3.1.2 - SRM INSTRUMENTATION

L.4 CHANGE

In accordance with the criteria set forth in 10 CFR 50.92, ComEd has evaluated this proposed Technical Specifications change and determined it does not represent a significant hazards consideration. The following is provided in support of this conclusion.

1. Does the change involve a significant increase in the probability or consequences of an accident previously evaluated?

The proposed change provides the allowance for SRM count rate to be below 3 cps with less than or equal to four fuel assemblies adjacent to the SRM. The SRMs are not considered as initiators of any analyzed event. This is considered acceptable since a provision of this allowance requires no other fuel assemblies to be located in the associated core quadrant. In this condition, even with a control rod withdrawn, the configuration will not be critical. In addition, after loading more than four fuel assemblies adjacent to the SRM or a fuel assembly in the associated core quadrant, the 3 cps count rate must be met. As such, the Surveillance will continue to be performed at its normal Frequency which has been shown to be adequate for assuring the equipment is available and capable of performing its intended function and there is no impact on the capability of the system to perform its required safety function. Therefore, the proposed change does not involve a significant increase in the probability or consequences of an accident previously evaluated.

2. Does the change create the possibility of a new or different kind of accident from any accident previously evaluated?

The proposed change does not create the possibility of a new or different kind of accident from any accident previously evaluated because the change does not introduce a new mode of plant operation and does not involve physical modification to the plant.

3. Does this change involve a significant reduction in a margin of safety?

The proposed change extends the allowance for SRM count rate to be below 3 cps when less than or equal to four fuel assemblies are adjacent to the SRM. This is acceptable since this allowance only applies when no other fuel assemblies are located in the associated core quadrant. In this condition, even with a control rod withdrawn, the configuration will not be critical. At other times, when the provisions of the Note are not satisfied, ITS SR 3.3.1.2.4 requires the SRM minimum count rate of 3 cps to be met. In addition, the normal Surveillance Frequency has been shown, based on operating experience, to be adequate for assuring the equipment is available and capable of performing its intended function. The requirements of ITS 3.3.1.2 Required Action E.1 preclude beginning CORE ALTERATIONS unless the required equipment is OPERABLE and all required Surveillances are met. Therefore, the proposed change does not involve a significant reduction in a margin of safety.

NO SIGNIFICANT HAZARDS CONSIDERATION
ITS: 3.3.1.2 - SRM INSTRUMENTATION

L.5 CHANGE

In accordance with the criteria set forth in 10 CFR 50.92, ComEd has evaluated this proposed Technical Specifications change and determined it does not represent a significant hazards consideration. The following is provided in support of this conclusion.

1. Does the change involve a significant increase in the probability or consequences of an accident previously evaluated?

The change extends the time period to insert all insertable control rods and provides a Required Action to immediately initiate action and continue attempts to insert all insertable control rods. The SRMs and requirements to fully insert all insertable control rods immediately during refueling conditions if one or more SRMs are inoperable are not assumed in the initiation of any previously analyzed accident. As such, the proposed change will not increase the probability of any accident previously evaluated. Therefore, this change ensures that actions are taken to insert all insertable control rods in a timely manner while continuing to provide direction if attempts fail to immediately insert all insertable control rods. In addition, the consequences of an event occurring under the proposed action are the same as the consequences of an event occurring under the current action. Therefore, this change does not involve an increase in the consequences of any accident previously evaluated.

2. Does the change create the possibility of a new or different kind of accident from any accident previously evaluated?

The proposed change does not create the possibility of a new or different kind of accident from any accident previously evaluated because the change does not introduce a new mode of plant operation and does not involve physical modification to the plant.

3. Does this change involve a significant reduction in a margin of safety?

During MODE 5, fully inserting all insertable control rods immediately may not always be possible. In this situation, the CTS do not provide direction as to the action to take. The proposed change provides a Required Action to immediately initiate action and continue attempts to insert all insertable control rods. This change ensures that actions are taken to insert all insertable control rods in a timely manner while continuing to provide direction if attempts fail to immediately insert all insertable control rods. This change is considered to be acceptable since ITS 3.3.1.2 Required Action E.1 ensures the probability of occurrence of postulated events involving changes in reactivity in the MODE 5 is minimized by suspension of CORE ALTERATIONS. Therefore, the proposed change does not involve a significant reduction in a margin of safety.

NO SIGNIFICANT HAZARDS CONSIDERATION
ITS: 3.3.1.2 - SRM INSTRUMENTATION

L.6 CHANGE

In accordance with the criteria set forth in 10 CFR 50.92, ComEd has evaluated this proposed Technical Specifications change and determined it does not represent a significant hazards consideration. The following is provided in support of this conclusion.

1. Does the change involve a significant increase in the probability or consequences of an accident previously evaluated?

This proposed change eliminates the requirement to fully insert control rods in core cells that do not contain fuel assemblies when the required SRM instrumentation is inoperable. Fully inserting control rods in core cells that contain no fuel assemblies has an insignificant impact on core reactivity and therefore, serves no purpose. The SRMs and associated actions are not considered as initiators for any accidents previously analyzed. Therefore, this change does not significantly increase the probability of a previously analyzed accident. Further, since control rods withdrawn from or inserted into a core cell containing no fuel assemblies have a negligible impact on the reactivity of the core, the consequences of an event occurring under the proposed action are the same as the consequences of an event occurring under the current action. Therefore, this change does not significantly increase the consequences of a previously analyzed accident.

2. Does the change create the possibility of a new or different kind of accident from any accident previously evaluated?

The change does not necessitate a physical alteration of the plant (no new or different type of equipment will be installed) or changes in parameters governing normal operation. The proposed change still ensures that control rods which do have an impact on core reactivity are inserted in this condition. Therefore, it does not create the possibility of a new or different kind of accident from any accident previously evaluated.

3. Does this change involve a significant reduction in a margin of safety?

During MODE 5, fully inserting all insertable control rods in core cells containing no fuel assemblies is not necessary. In this situation, the ITS actions are adequate to ensure that the reactor is maintained subcritical since control rods withdrawn from or inserted into a core cell containing no fuel assemblies have a negligible impact on the reactivity of the core. Therefore, the proposed change does not involve a significant reduction in a margin of safety.

NO SIGNIFICANT HAZARDS CONSIDERATION
ITS: 3.3.1.2 - SRM INSTRUMENTATION

L.7 CHANGE

In accordance with the criteria set forth in 10 CFR 50.92, ComEd has evaluated this proposed Technical Specifications change and determined it does not represent a significant hazards consideration. The following is provided in support of this conclusion.

1. Does the change involve a significant increase in the probability or consequences of an accident previously evaluated?

This change will limit the required applicability for source range monitors in MODE 5 to those monitors which are capable of providing the necessary function. SRMs are not considered as an initiator for any accidents previously analyzed. Therefore, this change does not significantly increase the probability of a previously analyzed accident. Also, this change does not degrade the capability of the system to perform its design basis function. Therefore, this change does not significantly increase the consequences of a previously analyzed accident.

2. Does the change create the possibility of a new or different kind of accident from any accident previously evaluated?

The proposed change introduces no change to the intended monitoring function provided by the SRMs, and it does not involve physical modification to the plant. Therefore, it does not create the possibility of a new or different kind of accident from any accident previously evaluated.

3. Does this change involve a significant reduction in a margin of safety?

This change does not involve a significant reduction in a margin of safety. The remaining SRM is adequate to assist the response to an inadvertent criticality since the core configuration must follow a spiral load/discharge for which the probability of an inadvertent criticality is negligible.

NO SIGNIFICANT HAZARDS CONSIDERATION
ITS: 3.3.1.2 - SRM INSTRUMENTATION

L.8 CHANGE

In accordance with the criteria set forth in 10 CFR 50.92, ComEd has evaluated this proposed Technical Specifications change and determined it does not represent a significant hazards consideration. The following is provided in support of this conclusion.

1. Does the change involve a significant increase in the probability or consequences of an accident previously evaluated?

This change adds an allowance to allow the SRM count rate to be reduced as long as its count rate is at least 0.7 cps with a signal to noise ratio $\geq 20:1$. The optional count rate of at least 0.7 cps with a signal to noise ratio $\geq 20:1$ is acceptable since the SRMs could still monitor neutron counts with the same confidence as in the current value. The high signal to noise ratio is required so that the SRM can distinguish between actual counts and noise at the lower count rates. The SRMs are not considered as initiators of any analyzed event. Therefore, this change does not result in a significant increase in the probability of an accident previously evaluated. The SRMs will still be able to monitor changes in neutron flux. Therefore, the proposed change does not involve a significant increase in the probability or consequences of an accident previously evaluated.

2. Does the change create the possibility of a new or different kind of accident from any accident previously evaluated?

The proposed change does not create the possibility of a new or different kind of accident from any accident previously evaluated because the change does not introduce a new mode of plant operation and does not involve physical modification to the plant.

3. Does this change involve a significant reduction in a margin of safety?

This change adds an allowance to allow the SRM count rate to be reduced as long as its count rate is at least 0.7 cps with a signal to noise ratio $\geq 20:1$. The optional count rate of at least 0.7 cps with a signal to noise ratio $\geq 20:1$ is acceptable since the SRMs could still monitor neutron counts with the same confidence as in the current value. The high signal to noise ratio is required so that the SRM can distinguish between actual counts and noise at the lower count rates. The SRMs will still be able to monitor changes in neutron flux. Therefore, the proposed change does not involve a significant reduction in a margin of safety.

NO SIGNIFICANT HAZARDS CONSIDERATION
ITS: 3.3.2.1 - CONTROL ROD BLOCK INSTRUMENTATION

L.1 CHANGE

In accordance with the criteria set forth in 10 CFR 50.92, ComEd has evaluated this proposed Technical Specifications change and determined it does not represent a significant hazards consideration. The following is provided in support of this conclusion.

1. Does the change involve a significant increase in the probability or consequences of an accident previously evaluated?

The proposed change removes an unnecessary additional performance of a Surveillance that has been performed within its normally required Frequency. The RBM Instrumentation and associated Surveillance Requirements are not assumed to be initiators of any analyzed event. Further, since the Surveillance continues to be performed on its normal Frequency (92 days), there is no impact on the capability of the RBM system to perform its required safety function. The consequences of an accident are not affected since the consequences of a design basis accident with the RBM Functions inoperable in the 7 day period (due to an undetected failure) are the same as the consequences of a design basis accident with the RBM Functions inoperable for the proposed 92 day period. Additionally, the most common outcome of the performance of a Surveillance is the successful demonstration that the acceptance criteria are satisfied. Therefore, the proposed change does not involve a significant increase in the probability or consequences of an accident previously evaluated.

2. Does the change create the possibility of a new or different kind of accident from any accident previously evaluated?

The proposed change does not create the possibility of a new or different kind of accident from any accident previously evaluated because the proposed change does not introduce a new mode of plant operation and does not require physical modification to the plant.

3. Does this change involve a significant reduction in a margin of safety?

The normal Surveillance Frequency has been shown, per the reliability analysis of NEDO-30851P-A, "Technical Specifications Improvement Analysis for BWR Control Rod Block Instrumentation," dated October 1988, to be adequate for assuring the RBM Instrumentation is available and capable of performing its intended function. Additionally, the requirements of ITS SR 3.0.4 (CTS 4.0.D) provide assurance that the RBM is OPERABLE prior to entering conditions for which the RBM is required.

- * Also, the change provides the benefit of eliminating unnecessary testing prior to a reactor startup thereby reducing the wear on the instruments and increasing overall reliability. As a result, the proposed change does not involve a significant reduction in a margin of safety.

NO SIGNIFICANT HAZARDS CONSIDERATION
ITS: 3.3.2.1 - CONTROL ROD BLOCK INSTRUMENTATION

L.2 CHANGE

In accordance with the criteria set forth in 10 CFR 50.92, ComEd has evaluated this proposed Technical Specifications change and determined it does not represent a significant hazards consideration. The following is provided in support of this conclusion.

1. Does the change involve a significant increase in the probability or consequences of an accident previously evaluated?

This change will increase the surveillance interval of the CHANNEL FUNCTIONAL TEST to once every 92 days and allow the test to be performed 1 hour after the applicable condition is entered. The RWM is a highly accurate system, which has been shown to be reliable. In addition, other similar rod block Functions have a 92 day CHANNEL FUNCTIONAL TEST. This Frequency has been determined to be adequate in accordance with previously approved setpoint methodology. Also, the additional 1 hour allows time after the appropriate conditions are established to perform the test. Therefore, this change does not significantly increase the probability of a previously analyzed accident. An increase of the surveillance interval will not affect the capability of the component or system to perform its function nor alter assumptions relative to the mitigation of an accident. Therefore, this change does not significantly increase the consequences of a previously analyzed accident.

2. Does the change create the possibility of a new or different kind of accident from any accident previously evaluated?

The proposed change does not introduce a new mode of plant operation and does not involve physical modification to the plant. Therefore, it does not create the possibility of a new or different kind of accident from any accident previously evaluated.

3. Does this change involve a significant reduction in a margin of safety?

This change does not involve a significant reduction in a margin of safety since experience has shown that the components usually pass the surveillance when performed at the proposed frequency.

NO SIGNIFICANT HAZARDS CONSIDERATION
ITS: 3.3.2.1 - CONTROL ROD BLOCK INSTRUMENTATION

L.3 CHANGE

In accordance with the criteria set forth in 10 CFR 50.92, ComEd has evaluated this proposed Technical Specifications change and determined it does not represent a significant hazards consideration. The following is provided in support of this conclusion.

1. Does the change involve a significant increase in the probability or consequences of an accident previously evaluated?

The RBM is not assumed to be an initiator of any analyzed event. The change deletes an unnecessary restriction when one RBM is inoperable. Since the other channel remains OPERABLE, the RBM is capable of performing its safety function. In addition, the change also deletes an unnecessary surveillance requirement. Since the surveillance continues to be performed on its normal, quarterly frequency, there is no impact on the capability of the RBM to perform its required safety function. Therefore, the proposed change does not involve a significant increase in the probability or consequences of an accident previously evaluated.

2. Does the change create the possibility of a new or different kind of accident from any accident previously evaluated?

The proposed change does not create the possibility of a new or different kind of accident from any accident previously evaluated, because the proposed change does not introduce a new mode of plant operation and does not require physical modification to the plant.

3. Does this change involve a significant reduction in a margin of safety?

Increasing the time (by deleting CTS 3.3.M Action 1.a) allowed to operate with one RBM inoperable while operating on a LIMITING CONTROL ROD PATTERN is acceptable based on the small probability of an event requiring the RBM to function. One RBM continues to be OPERABLE during this time and is capable of performing the required safety function. In addition, the probability of actually operating on a LIMITING CONTROL ROD PATTERN is very low. The Surveillance Requirement deletion is acceptable, since the normal Surveillance Frequency has been shown, based on operating experience, to be adequate for assuring the RBM channels are OPERABLE. Therefore, the proposed change does not involve a significant reduction in a margin of safety.

NO SIGNIFICANT HAZARDS CONSIDERATION
ITS: 3.3.2.2 - FEEDWATER SYSTEM AND MAIN TURBINE HIGH WATER
LEVEL TRIP INSTRUMENTATION

L.1 CHANGE

In accordance with the criteria set forth in 10 CFR 50.92, ComEd has evaluated this proposed Technical Specifications change and determined it does not represent a significant hazards consideration. The following is provided in support of this conclusion.

1. Does the change involve a significant increase in the probability or consequences of an accident previously evaluated?

This change will reduce the applicable conditions for the feedwater pump trip instrumentation to only $\geq 25\%$ RTP. The feedwater pump trip instrumentation is provided to protect against violation of the MCPR Safety Limit. However, adequate margin exists such that MCPR is not a concern below 25% RTP. The affected RPS function is not considered as an initiator for any accidents previously analyzed. Therefore, this change does not significantly increase the probability of a previously analyzed accident. Further, this function is not credited for mitigation of any accident in the omitted conditions. Therefore, this change does not significantly increase the consequences of a previously analyzed accident.

2. Does the change create the possibility of a new or different kind of accident from any accident previously evaluated?

The proposed change introduces no new mode of plant operation and it does not involve physical modification to the plant. Therefore, it does not create the possibility of a new or different kind of accident from any accident previously evaluated.

3. Does this change involve a significant reduction in a margin of safety?

This change does not involve a significant reduction in a margin of safety since the function is not credited below 25% RTP and the large safety margins in the thermal limits, inherent in the plant below 25% RTP, are not affected.

NO SIGNIFICANT HAZARDS CONSIDERATION
ITS: 3.3.2.2 - FEEDWATER SYSTEM AND MAIN TURBINE HIGH WATER
LEVEL TRIP INSTRUMENTATION

L.2 CHANGE

In accordance with the criteria set forth in 10 CFR 50.92, ComEd has evaluated this proposed Technical Specifications change and determined it does not represent a significant hazards consideration. The following is provided in support of this conclusion.

1. Does the change involve a significant increase in the probability or consequences of an accident previously evaluated?

This change will allow a feedwater pump to be removed from service to satisfy the Required Actions and allow continued operation. The Feedwater Pump Trip instrumentation is not assumed to be an initiator of any analyzed event. Therefore, this change does not significantly increase the probability of a previously analyzed accident. Removing the feedwater pump from service, when the instrumentation is inoperable solely due to an inoperable feedwater pump breaker, provides the required safety function. Therefore, this change does not significantly increase the consequences of a previously analyzed accident.

2. Does the change create the possibility of a new or different kind of accident from any accident previously evaluated?

The proposed change does not introduce a new mode of plant operation and does not involve physical modification to the plant. Therefore, it does not create the possibility of a new or different kind of accident from any accident previously evaluated.

3. Does this change involve a significant reduction in a margin of safety?

This change does not involve a significant reduction in a margin of safety since the safety function continues to provide the required Feedwater Pump Trip capability, including single failure conditions.

NO SIGNIFICANT HAZARDS CONSIDERATION
ITS: 3.3.3.1 - POST ACCIDENT MONITORING INSTRUMENTATION

L.1 CHANGE

In accordance with the criteria set forth in 10 CFR 50.92, ComEd has evaluated this proposed Technical Specifications change and determined it does not represent a significant hazards consideration. The following is provided in support of this conclusion.

1. Does the change involve a significant increase in the probability or consequences of an accident previously evaluated?

This change will allow entry into the applicable MODE with a Post Accident Monitoring (PAM) instrument inoperable. The PAM instrument channels are not assumed to be initiators of any analyzed event. The role of this instrumentation is in providing the operators information during and after an accident to allow them to take mitigating actions, thereby limiting consequences. With the proposed change, sufficient indication or alternate methods to monitor the parameter will remain OPERABLE to provide the operator with information necessary to evaluate potential plant conditions. In addition, the PAM instruments do not provide an active function to mitigate the consequences of any design basis accident or transient. Therefore, this change will not involve a significant increase in the probability or consequences of an accident previously evaluated.

2. Does the change create the possibility of a new or different kind of accident from any accident previously evaluated?

The proposed change does not necessitate a physical alteration of the plant (no new or different type of equipment will be installed) or changes in parameters governing normal operation. Therefore, this change will not create the possibility of a new or different kind of accident from any accident previously evaluated.

3. Does this change involve a significant reduction in a margin of safety?

This change does not involve a significant reduction in a margin of safety since the instrumentation is not required to provide automatic response to any design basis accident or transient and the Technical Specifications will ensure that adequate indication of the affected parameter(s) is maintained for use by the operators.

NO SIGNIFICANT HAZARDS CONSIDERATION
ITS: 3.3.3.1 - POST ACCIDENT MONITORING INSTRUMENTATION

L.2 CHANGE

In accordance with the criteria set forth in 10 CFR 50.92, ComEd has evaluated this proposed Technical Specifications change and determined it does not represent a significant hazards consideration. The following is provided in support of this conclusion.

1. Does the change involve a significant increase in the probability or consequences of an accident previously evaluated?

The change modifies the Surveillance to indicate when a channel is placed in an inoperable status solely for performance of required Surveillances, entry into associated Conditions and Required Actions may be delayed for up to 6 hours, provided the other required channel in the associated Function are OPERABLE. The PAMs are not considered as an initiator for any accidents previously analyzed. Therefore, this change does not significantly increase the probability of a previously analyzed accident. Also, this change does not further degrade the capability of the monitors to perform their required function under these circumstances since one channel is still OPERABLE. In addition, if an accident should occur while the Surveillance is being performed, the instrument can be restored to OPERABLE status in a short period of time. Therefore, this change does not significantly increase the consequences of a previously analyzed accident.

2. Does the change create the possibility of a new or different kind of accident from any accident previously evaluated?

The proposed change does not introduce a new mode of plant operation and does not involve physical modification to the plant. Therefore, it does not create the possibility of a new or different kind of accident from any accident previously evaluated.

3. Does this change involve a significant reduction in a margin of safety?

This change does not involve a significant reduction in a margin of safety since the monitors are not required to provide automatic response to any design basis accident. The additional time does not significantly affect the contribution of the monitors to risk reduction since the function is still being monitored by the other OPERABLE channel.

NO SIGNIFICANT HAZARDS CONSIDERATION
ITS: 3.3.3.1 - POST ACCIDENT MONITORING INSTRUMENTATION

L.3 CHANGE

In accordance with the criteria set forth in 10 CFR 50.92, ComEd has evaluated this proposed Technical Specifications change and determined it does not represent a significant hazards consideration. The following is provided in support of this conclusion.

1. Does the change involve a significant increase in the probability or consequences of an accident previously evaluated?

This change will revise the Required Actions for inoperable PAM channels that are not restored to service within the allowable outage time. The PAM instrument channels are not assumed to be initiators of any analyzed event. The role of this instrumentation is in providing the operators information during and after an accident to allow them to take mitigating actions, thereby limiting consequences. The requested change does not allow continuous operation such that a single failure could result in a loss of function since the report requires an alternate means be established to monitor the affected parameter. Additionally, the consequences of an event occurring with the proposed actions are no worse than the consequences of an event occurring with the existing shutdown actions. Therefore, this change will not involve a significant increase in the probability or consequences of an accident previously evaluated.

2. Does the change create the possibility of a new or different kind of accident from any accident previously evaluated?

The proposed change does not necessitate a physical alteration of the plant (no new or different type of equipment will be installed) or changes in parameters governing normal operation. The proposed change will allow alternate means for monitoring the parameters be credited when PAM instrument channels are inoperable. Therefore, this change will not create the possibility of a new or different kind of accident from any accident previously evaluated.

3. Does this change involve a significant reduction in a margin of safety?

The proposed action allowing continued operation provided alternate means of monitoring the affected parameters are identified and justified in a report to the NRC is acceptable based on the small probability of an event requiring the PAM instrumentation, the passive function of these instruments, and the alternate means of monitoring the affected parameter. This alternate means must be established and available to utilize the provisions of the proposed action. Providing this proposed action will minimize the potential for plant transients that can occur during plant shutdowns. As such, any reduction in a margin of safety will be offset by the benefit gained by avoiding an unnecessary plant shutdown transient when alternate monitoring capability exists. Therefore, this change does not involve a significant reduction in a margin of safety.

NO SIGNIFICANT HAZARDS CONSIDERATION
ITS: 3.3.3.1 - POST ACCIDENT MONITORING INSTRUMENTATION

L.4 CHANGE

In accordance with the criteria set forth in 10 CFR 50.92, ComEd has evaluated this proposed Technical Specifications change and determined it does not represent a significant hazards consideration. The following is provided in support of this conclusion.

1. Does the change involve a significant increase in the probability or consequences of an accident previously evaluated?

This change will allow 7 days to restore one inoperable PAM instrument channel when two PAM instrument channels are inoperable, thus minimizing the potential for a shutdown transient. The PAM instrument channels are not assumed to be initiators of any analyzed event. The role of this instrumentation is in providing the operators information during and after an accident to allow them to take mitigating actions, thereby limiting consequences. The requested change does not allow continuous operation since the available alternate indications may not fully meet all performance qualification requirements applied to the instruments. Additionally, the consequences of an event occurring with the proposed actions are no worse than the consequences of an event occurring with the existing shutdown actions. Therefore, this change will not involve a significant increase in the probability or consequences of an accident previously evaluated.

2. Does the change create the possibility of a new or different kind of accident from any accident previously evaluated?

The proposed change does not necessitate a physical alteration of the plant (no new or different type of equipment will be installed) or changes in parameters governing normal operation. Therefore, this change will not create the possibility of a new or different kind of accident from any accident previously evaluated.

3. Does this change involve a significant reduction in a margin of safety?

The proposed action is acceptable based on the small probability of an event requiring the PAM instrumentation, the passive function of these instruments, and the alternate means of monitoring the affected parameter. Providing this proposed action will minimize the potential for plant transients that can occur during plant shutdowns by providing additional time for restoration of PAM instrument channel(s). As such, any reduction in a margin of safety will be offset by the benefit gained by avoiding an unnecessary plant shutdown transient when alternate monitoring capability exists.

Therefore, this change does not involve a significant reduction in a margin of safety.

NO SIGNIFICANT HAZARDS CONSIDERATION
ITS: 3.3.3.1 - POST ACCIDENT MONITORING INSTRUMENTATION

L.5 CHANGE

In accordance with the criteria set forth in 10 CFR 50.92, ComEd has evaluated this proposed Technical Specifications change and determined it does not represent a significant hazards consideration. The following is provided in support of this conclusion.

1. Does the change involve a significant increase in the probability or consequences of an accident previously evaluated?

The change allows 30 days to restore one inoperable drywell area radiation monitor when one monitor is inoperable and 7 days to restore one inoperable drywell area radiation monitor when two monitors are inoperable or to initiate the alternate method of monitoring, thus minimizing the potential for a shutdown transient. This change does not result in any hardware changes. The drywell area radiation monitors are not initiators of any analyzed event. The role of this instrumentation is in providing the operators information relative to primary containment radiation levels during and after an accident to allow them to take mitigating actions, thereby limiting consequences. The requested change does not allow continuous operation since the available alternate indications may not fully meet all performance qualification requirements applied to the drywell area radiation monitors. Additionally, the consequences of an event occurring with the proposed actions are the same as the consequences of an event occurring within the allowed outage time of the current actions. Therefore, this change will not involve a significant increase in the probability or consequences of an accident previously evaluated.

2. Does the change create the possibility of a new or different kind of accident from any accident previously evaluated?

The proposed change does not introduce a new mode of plant operation and does not involve physical modification to the plant. Therefore, it does not create the possibility of a new or different kind of accident from any accident previously evaluated.

3. Does this change involve a significant reduction in a margin of safety?

The proposed change is acceptable based on the small probability of an event requiring the drywell area radiation monitors during the time period, the passive nature of the monitors, the availability of the redundant monitor (for the condition of one monitor inoperable) and the availability of alternate means to obtain the required information. Providing the proposed action will minimize the potential for plant transients that can occur during shutdown by providing additional time for the restoration of one monitor or the initiation of an alternate means of monitoring. As such, any reduction in a margin of safety resulting from the proposed change will be offset by the benefit gained by avoiding an unnecessary plant shutdown transient. Therefore, this change does not involve a significant reduction in a margin of safety.

NO SIGNIFICANT HAZARDS CONSIDERATION
ITS: 3.3.3.1 - POST ACCIDENT MONITORING INSTRUMENTATION

L.6 CHANGE

In accordance with the criteria set forth in 10 CFR 50.92, ComEd has evaluated this proposed Technical Specifications change and determined it does not represent a significant hazards consideration. The following is provided in support of this conclusion.

1. Does the change involve a significant increase in the probability or consequences of an accident previously evaluated?

The proposed change will limit the Applicability for Drywell Area Radiation monitors to the MODES during which design basis events are assumed to occur. Drywell Area Radiation monitors are not assumed to be initiators of any analyzed event. The role of these monitors is in providing the operators information during and after an accident to allow them to take mitigating actions, thereby limiting consequences. The variable monitored by the Drywell Area Radiation monitors is related to the diagnosis and preplanned actions required to mitigate design basis accidents (DBAs). The applicable DBAs are assumed to occur in MODES 1 and 2. The revision to the Applicability is being made consistent with the applicable DBA analyses. As a result, DBA consequences are not increased by this change. Therefore, this change will not involve a significant increase in the probability or consequences of an accident previously evaluated.

2. Does the change create the possibility of a new or different kind of accident from any accident previously evaluated?

The proposed change does not introduce a new mode of plant operation and does not involve physical modification to the plant. Therefore, it does not create the possibility of a new or different kind of accident from any accident previously evaluated.

3. Does this change involve a significant reduction in a margin of safety?

The proposed change is acceptable since it is being made consistent with the safety analysis assumptions. The Drywell Area Radiation monitors are provided to assist in the response to DBAs in the MODES which continue to be applicable. As such, the change still provides assurance the affected Drywell Area Radiation monitors will be maintained Operable during conditions when the DBAs are assumed to occur. Therefore, this change does not involve a significant reduction in a margin of safety.

NO SIGNIFICANT HAZARDS CONSIDERATION
ITS: 3.3.4.1 - ATWS-RPT INSTRUMENTATION

L.1 CHANGE

In accordance with the criteria set forth in 10 CFR 50.92, ComEd has evaluated this proposed Technical Specifications change and determined it does not represent a significant hazards consideration. The following is provided in support of this conclusion.

1. Does the change involve a significant increase in the probability or consequences of an accident previously evaluated?

This change will allow the affected recirculation pump breaker(s) to be removed from service to satisfy the Required Actions and allow continued operation. The ATWS-RPT instrumentation is not assumed to be an initiator of any analyzed event. Therefore, this change does not significantly increase the probability of a previously analyzed accident. Removing the recirculation pump breaker(s) from service provides the required safety function. Therefore, this change does not significantly increase the consequences of a previously analyzed accident.

2. Does the change create the possibility of a new or different kind of accident from any accident previously evaluated?

The proposed change introduces no new mode of plant operation and it does not involve physical modification to the plant. Therefore, it does not create the possibility of a new or different kind of accident from any accident previously evaluated.

3. Does this change involve a significant reduction in a margin of safety?

This change does not involve a significant reduction in a margin of safety since the safety functions continue to provide the required ATWS-RPT actuation capability, including single failure conditions.

NO SIGNIFICANT HAZARDS CONSIDERATION
ITS: 3.3.4.1 - ATWS-RPT INSTRUMENTATION

L.2 CHANGE

In accordance with the criteria set forth in 10 CFR 50.92, ComEd has evaluated this proposed Technical Specifications change and determined it does not represent a significant hazards consideration. The following is provided in support of this conclusion:

1. Does the change involve a significant increase in the probability or consequences of an accident previously evaluated?

This change will allow an inoperable channel to be placed in the tripped condition to satisfy the Required Actions and allow continued operation. The ATWS-RPT instrumentation is not assumed to be an initiator of any analyzed event. Therefore, this change does not significantly increase the probability of a previously analyzed accident. A tripped channel continues to provide the required function. Therefore, this change does not significantly increase the consequences of a previously analyzed accident.

2. Does the change create the possibility of a new or different kind of accident from any accident previously evaluated?

The proposed change does not introduce a new mode of plant operation and does not involve physical modification to the plant. Therefore, it does not create the possibility of a new or different kind of accident from any accident previously evaluated.

3. Does this change involve a significant reduction in a margin of safety?

This change does not involve a significant reduction in a margin of safety since the Functions continue to provide the required ATWS-RPT actuation capability, including single failure conditions.

NO SIGNIFICANT HAZARDS CONSIDERATION
ITS: 3.3.4.1 - ATWS-RPT INSTRUMENTATION

L.3 CHANGE

In accordance with the criteria set forth in 10 CFR 50.92, ComEd has evaluated this proposed Technical Specifications change and determined it does not represent a significant hazards consideration. The following is provided in support of this conclusion.

1. Does the change involve a significant increase in the probability or consequences of an accident previously evaluated?

This change will identify Required Actions based on trip Function capability rather than single trip system OPERABILITY. The ATWS-RPT instrumentation is not assumed to be an initiator of any analyzed event. Therefore, this change does not significantly increase the probability of a previously analyzed accident. Either condition results in decreased capability with regard to single failures; however, as long as one Function is available, single failure capability must be restored or a shutdown will eventually be required in accordance with the proposed Required Actions. Therefore, this change does not significantly increase the probability or consequences of a previously analyzed accident.

2. Does the change create the possibility of a new or different kind of accident from any accident previously evaluated?

The proposed change does not introduce a new mode of plant operation and does not involve physical modification to the plant. Therefore, it does not create the possibility of a new or different kind of accident from any accident previously evaluated.

3. Does this change involve a significant reduction in a margin of safety?

This change does not involve a significant reduction in a margin of safety since at least one Function continues to provide the required ATWS-RPT actuation capability. In addition, operator action can be taken to trip the recirculation pumps if a ATWS event (which is a beyond basis event) occurs.

NO SIGNIFICANT HAZARDS CONSIDERATION
ITS: 3.3.5.1 - ECCS INSTRUMENTATION

There were no plant specific less restrictive changes identified for this Specification.

**NO SIGNIFICANT HAZARDS CONSIDERATION
ITS: 3.3.5.2 - RCIC SYSTEM INSTRUMENTATION**

There were no plant specific less restrictive changes identified for this Specification.

NO SIGNIFICANT HAZARDS CONSIDERATION
ITS: 3.3.6.1 - PRIMARY CONTAINMENT ISOLATION INSTRUMENTATION

L.1 CHANGE

In accordance with the criteria set forth in 10 CFR 50.92, ComEd has evaluated this proposed Technical Specifications change and determined it does not represent a significant hazards consideration. The following is provided in support of this conclusion.

1. Does the change involve a significant increase in the probability or consequences of an accident previously evaluated?

This change will provide additional time to isolate the penetration prior to commencing a plant shutdown however the proposed Required Action still requires the plant to be outside the MODE of applicability within the same time frame as other primary containment inoperabilities. Inoperable isolation instrumentation channels are not considered as an initiator for any accidents previously analyzed. This change also allows additional time to begin a plant shutdown, however still requires the plant to be shutdown in the same time frame. The action continues to provide sufficient time to perform an orderly shutdown and at the same time may further minimize a potential upset from a too rapid decrease in plant power. The consequences of an event occurring during the proposed Required Actions are the same as in the current Actions. Therefore, this change does not significantly increase the probability or consequences of a previously analyzed accident.

2. Does the change create the possibility of a new or different kind of accident from any accident previously evaluated?

The proposed change does not introduce a new mode of plant operation and does not involve physical modification to the plant. Therefore, it does not create the possibility of a new or different kind of accident from any accident previously evaluated.

3. Does this change involve a significant reduction in a margin of safety?

This change will provide additional time to isolate the penetration prior to commencing a plant shutdown however the proposed Required Action still requires the plant to be outside the MODE of applicability within the same time frame as other primary containment inoperabilities. The action continues to provide sufficient time to perform an orderly shutdown and at the same time may further minimize a potential upset from a too rapid decrease in plant power. The proposed actions will provide sufficient time to shut down and cooldown the plant. As a result, the potential for human error will be reduced. As such, any reduction in a margin of safety will be insignificant and offset by the benefit gained.

NO SIGNIFICANT HAZARDS CONSIDERATION
ITS: 3.3.6.1 - PRIMARY CONTAINMENT ISOLATION INSTRUMENTATION

L.2 CHANGE

In accordance with the criteria set forth in 10 CFR 50.92, ComEd has evaluated this proposed Technical Specifications change and determined it does not represent a significant hazards consideration. The following is provided in support of this conclusion.

1. Does the change involve a significant increase in the probability or consequences of an accident previously evaluated?

This change reduces the Applicability of the Standby Liquid Control (SLC) System Initiation Function from MODES 1, 2 and 3 to MODES 1 and 2, only and also modifies the default action for this Function from close the affected penetration in 1 hour to also provide the option to declare the SLC System inoperable. The reduction in the Applicability is acceptable since with the unit in MODE 3 the reactor will be shutdown with all control rods inserted. Therefore, the additional shutdown requirements of the Standby Liquid Control System will not be necessary to mitigate an ATWS event. The proposed Applicability is consistent with the Applicability of ITS 3.1.7 for the Standby Liquid Control System. The change which provides the option to declare the SLC System inoperable instead of isolating the penetration is also acceptable since the ITS 3.1.7 provides adequate compensatory action for other conditions where the SLC System is inoperable (SLC tank sodium pentaborate concentration not within limits). The SLC System Initiation Function is not considered as an initiator for any accidents previously analyzed. Therefore, this change does not significantly increase the probability of a previously analyzed accident. This change does not impact the capability of the system to perform its required function when needed since the control rods are inserted in MODE 3 and since ITS 3.1.7 provides adequate compensatory actions when the system is declared inoperable. Therefore, this change does not significantly increase the consequences of a previously analyzed accident.

2. Does the change create the possibility of a new or different kind of accident from any accident previously evaluated?

The proposed change does not introduce a new mode of plant operation and does not involve physical modification to the plant. Therefore, it does not create the possibility of a new or different kind of accident from any accident previously evaluated.

3. Does this change involve a significant reduction in a margin of safety?

This change does not involve a significant reduction in a margin of safety since other requirements prevent the withdrawal of control rods in MODE 3, thus the SLC System and SLC System Initiation Function is not necessary. In addition, since the CTS and ITS allow other SLC System inoperabilities, this change does not result in a significant reduction in the margin of safety.

NO SIGNIFICANT HAZARDS CONSIDERATION
ITS: 3.3.6.1 - PRIMARY CONTAINMENT ISOLATION INSTRUMENTATION

L.3 CHANGE

In accordance with the criteria set forth in 10 CFR 50.92, ComEd has evaluated this proposed Technical Specifications change and determined it does not represent a significant hazards consideration. The following is provided in support of this conclusion.

1. Does the change involve a significant increase in the probability or consequences of an accident previously evaluated?

The RHR shutdown cooling system isolation instrumentation is not assumed to be an initiator of any analyzed event. The instrumentation's role is in containing reactor coolant in analyzed events and thereby limiting consequences. The proposed change to the Actions allows the option to initiate action to restore the inoperable channels or to initiate action to isolate shutdown cooling, which is currently required. This allows an alternate decay heat removal method to be made available prior to isolating shutdown cooling. This change allows action to be taken to restore isolation capability without causing a loss of shutdown cooling. Therefore, this change will not involve a significant increase in the probability or consequences of an accident previously evaluated.

2. Does the change create the possibility of a new or different kind of accident from any accident previously evaluated?

The proposed change does not involve any design changes, plant modifications, or changes in plant operation. The proposed change continues to require action to be taken to isolate the penetration or restore the channels while still allowing an alternate decay heat removal method to be made available prior to isolating shutdown cooling. The system will continue to function in the same way as before the change. Therefore, the proposed change does not create the possibility of a new or different kind of accident from any previously evaluated.

3. Does this change involve a significant reduction in a margin of safety?

No significant reduction in a margin of safety is involved with this change since it assures that actions are taken to restore isolation capability. The change to the Action is acceptable based on the small probability of an event requiring shutdown cooling isolation and the desire to maintain adequate shutdown cooling. The exposure of the plant to the small probability of an event requiring shutdown cooling isolation is insignificant and offset by the benefit of avoiding a loss of shutdown cooling.

NO SIGNIFICANT HAZARDS CONSIDERATION
ITS: 3.3.6.1 - PRIMARY CONTAINMENT ISOLATION INSTRUMENTATION

L.4 CHANGE

In accordance with the criteria set forth in 10 CFR 50.92, ComEd has evaluated this proposed Technical Specifications change and determined it does not represent a significant hazards consideration. The following is provided in support of this conclusion.

1. Does the change involve a significant increase in the probability or consequences of an accident previously evaluated?

This change will provide additional time to isolate the main steam lines and will allow continued operation with inoperable channels if the affected main steam line penetration is isolated. Inoperable main steam isolation logic is not considered as an initiator for any accidents previously analyzed. The change will not allow continuous operation such that a single failure will preclude the affected isolation function from being performed. This change allows isolating the affected penetration, which fulfills the post accident function of the isolation logic. This change also allows an additional 4 hours to close the MSIVs, which provides a reasonable amount of time to perform an orderly closure of the valves (which requires entry into MODE 2), thus further minimizing a potential upset from a too rapid decrease in plant power. Additionally, the consequences of an event occurring while the unit is reducing power in order to close the MSIVs during the extra 4 hours is the same as the consequences of an event occurring for the current 8 hours. Therefore, this change does not significantly increase the probability or consequences of a previously analyzed accident.

2. Does the change create the possibility of a new or different kind of accident from any accident previously evaluated?

The proposed change does not introduce a new mode of plant operation and does not involve physical modification to the plant. Therefore, it does not create the possibility of a new or different kind of accident from any accident previously evaluated.

3. Does this change involve a significant reduction in a margin of safety?

The increased time allowed for isolating the main steam lines with inoperable channels is acceptable based on the small probability of an event requiring the inoperable channels to function, the ability to isolate the main steam lines manually if an event occurs, and the minimization of plant transients. In addition, with the affected main steam line isolated, the safety function of the inoperable channels has been fulfilled. The proposed 4 hour extension will provide sufficient time for the unit to close the MSIVs. As a result, the potential for human error will be reduced. As such, any reduction in a margin of safety will be insignificant and offset by the benefit gained from providing sufficient time to close the MSIVs, thus avoiding potential plant transients from attempting to close the MSIVs in the current time.

NO SIGNIFICANT HAZARDS CONSIDERATION
ITS: 3.3.6.2 - SECONDARY CONTAINMENT ISOLATION INSTRUMENTATION

L.1 CHANGE

In accordance with the criteria set forth in 10 CFR 50.92, ComEd has evaluated this proposed Technical Specifications change and determined it does not represent a significant hazards consideration. The following is provided in support of this conclusion.

1. Does the change involve a significant increase in the probability or consequences of an accident previously evaluated?

This change will remove requirements for OPERABILITY of secondary containment isolation instrumentation on low reactor vessel water level during CORE ALTERATIONS. Secondary containment isolation instrumentation is not considered as an initiator for any accidents previously analyzed. Therefore, this change does not significantly increase the probability of a previously analyzed accident. Further, secondary containment isolation and SGT System actuation on low water level is not assumed in the mitigation of previously analyzed events occurring during a CORE ALTERATION. Therefore, this change does not significantly increase the consequences of a previously analyzed accident.

2. Does the change create the possibility of a new or different kind of accident from any accident previously evaluated?

The proposed change does not introduce a new mode of plant operation and does not involve physical modification to the plant. Therefore, it does not create the possibility of a new or different kind of accident from any accident previously evaluated.

3. Does this change involve a significant reduction in a margin of safety?

This change does not involve a significant reduction in a margin of safety since the requirements continue to provide OPERABILITY of the secondary containment isolation instrumentation function under conditions assumed in the safety analyses.

NO SIGNIFICANT HAZARDS CONSIDERATION
ITS: 3.3.6.2 - SECONDARY CONTAINMENT ISOLATION INSTRUMENTATION

L.2 CHANGE

In accordance with the criteria set forth in 10 CFR 50.92, ComEd has evaluated this proposed Technical Specifications change and determined it does not represent a significant hazards consideration. The following is provided in support of this conclusion.

1. Does the change involve a significant increase in the probability or consequences of an accident previously evaluated?

The change provides the option to declare the affected systems inoperable instead of closing the SCIVs and placing the SGT System in operation. The secondary containment isolation instrumentation is not assumed to be an initiator of any analyzed event. The role of the instrumentation is to mitigate and thereby limit the consequences of a design basis accident. The instrumentation actuates to ensure the SCIVs are closed and SGT System is initiated to ensure secondary containment leakage is limited during a design basis accident. The proposed change to the ACTIONS will not allow continuous operation such that a single failure will preclude SCIV or SGT System initiation from mitigating the consequences of a design basis accident. Therefore, the proposed change will not involve a significant increase in the probability or consequences of an accident previously evaluated.

2. Does the change create the possibility of a new or different kind of accident from any accident previously evaluated?

The proposed change does not introduce a new mode of plant operation and does not involve physical modification to the plant. Therefore, it does not create the possibility of a new or different kind of accident from any accident previously evaluated.

3. Does this change involve a significant reduction in a margin of safety?

No significant reduction in a margin of safety is involved with this change since the proposed alternative actions are identical to those associated with the mechanical Specifications (SGT System and SCIVs). Since the instrumentation actuates the SGT subsystems and the SCIVs, these actions are appropriate and the margin of safety is maintained equivalent to the margin of safety when the SGT systems are inoperable or if the SCIVs are inoperable.

**NO SIGNIFICANT HAZARDS CONSIDERATION
ITS: 3.3.6.3 - RELIEF VALVE INSTRUMENTATION**

There were no plant specific less restrictive changes identified for this Specification.

NO SIGNIFICANT HAZARDS CONSIDERATION
ITS: 3.3.7.1 - CREV SYSTEM INSTRUMENTATION

L.1 CHANGE

In accordance with the criteria set forth in 10 CFR 50.92, ComEd has evaluated this proposed Technical Specifications change and determined it does not represent a significant hazards consideration. The following is provided in support of this conclusion.

1. Does the change involve a significant increase in the probability or consequences of an accident previously evaluated?

This change requires (within 1 hour) either an actuation of the associated equipment (e.g., CREV System Isolation Valves) or a declaration that the CREV System is inoperable if the Main Steam Line Flow—High channels are inoperable and are not tripped within the allowed out-of-service time. The current Specification requires the plant to be in at least STARTUP with the associated isolation valves (main steam) closed within 8 hours or to shutdown. The CREV System isolation instrumentation is not assumed to be an initiator of any analyzed event. The role of the instrumentation is to mitigate and thereby limit the consequences of a design basis accident. The instrumentation actuates to ensure the control room is isolated so that the CREV System can be manually initiated to ensure main control room dose is limited during a design basis accident. The proposed change to the Actions will not allow continuous operation such that a single failure will preclude CREV System isolation initiation from mitigating the consequences of a design basis accident. Therefore, the proposed change will not involve a significant increase in the probability or consequences of an accident previously evaluated.

2. Does the change create the possibility of a new or different kind of accident from any accident previously evaluated?

The proposed change does not introduce a new mode of plant operation and does not involve physical modification to the plant. Therefore, it does not create the possibility of a new or different kind of accident from any accident previously evaluated.

3. Does this change involve a significant reduction in a margin of safety?

No significant reduction in a margin of safety is involved with this change since the Required Actions either isolate each required control room ventilation flow path or requires a declaration that the CREV System is inoperable. Compensatory actions currently exist for this second action. This change also provides a benefit through the potential avoidance of a plant shutdown when alternate compensatory measures are available to ensure the intended function of the instrumentation and associated equipment is satisfied.

NO SIGNIFICANT HAZARDS CONSIDERATION
ITS: 3.3.7.1 - CREV SYSTEM INSTRUMENTATION

L.2 CHANGE

In accordance with the criteria set forth in 10 CFR 50.92, ComEd has evaluated this proposed Technical Specifications change and determined it does not represent a significant hazards consideration. The following is provided in support of this conclusion.

1. Does the change involve a significant increase in the probability or consequences of an accident previously evaluated?

This change will remove requirements for OPERABILITY of CREV System isolation instrumentation on low reactor vessel water level during CORE ALTERATIONS. CREV System isolation instrumentation is not considered as an initiator for any accidents previously analyzed. Therefore, this change does not significantly increase the probability of a previously analyzed accident. Further, CREV System isolation on low water level is not assumed in the mitigation of previously analyzed events occurring during a CORE ALTERATION. Therefore, this change does not significantly increase the consequences of a previously analyzed accident.

2. Does the change create the possibility of a new or different kind of accident from any accident previously evaluated?

The proposed change does not introduce a new mode of plant operation and does not involve physical modification to the plant. Therefore, it does not create the possibility of a new or different kind of accident from any accident previously evaluated.

3. Does this change involve a significant reduction in a margin of safety?

This change does not involve a significant reduction in a margin of safety since the requirements continue to provide OPERABILITY of the CREV System Isolation instrumentation function under conditions assumed in the safety analyses.

NO SIGNIFICANT HAZARDS CONSIDERATION
ITS: 3.3.7.2 - MECHANICAL VACUUM PUMP TRIP INSTRUMENTATION

There were no plant specific less restrictive changes identified for this Specification.

NO SIGNIFICANT HAZARDS CONSIDERATION
ITS: 3.3.8.1 - LOSS OF POWER (LOP) INSTRUMENTATION

L.1 CHANGE

In accordance with the criteria set forth in 10 CFR 50.92, ComEd has evaluated this proposed Technical Specifications change and determined it does not represent a significant hazards consideration. The following is provided in support of this conclusion.

1. Does the change involve a significant increase in the probability or consequences of an accident previously evaluated?

The LOP instrumentation is not assumed to be an initiator of any analyzed event. The instrumentations role is in mitigating and thereby limiting the consequences of design basis events. The instrumentation actuates to ensure the diesel generators are initiated to ensure power is provided to required safety systems during a design basis event. The proposed change will not allow continuous operation such that a single failure will preclude the diesel generators from mitigating the consequences of design basis accidents or transients. The allowance provided for testing is only applicable for a limited time (2 hours) provided the associated Function maintains initiation capability for one diesel generator and associated 4160 V ESS bus. Since only one of the two diesel generators are necessary to start and one of the two 4160 V ESS buses are required to be energized to mitigate the consequences of a design basis event, the consequences of an event occurring during the 2 hour time period are the same as an event occurring during the Completion Time of the current Actions. Therefore, this change will not involve a significant increase in the probability or consequences of an accident previously evaluated.

2. Does the change create the possibility of a new or different kind of accident from any accident previously evaluated?

The proposed change does not introduce a new mode of plant operation and does not involve physical modification to the plant. Therefore, it does not create the possibility of a new or different kind of accident from any accident previously evaluated.

3. Does this change involve a significant reduction in a margin of safety?

The proposed change will allow entry into the Conditions and Required Actions for a LOP instrument channel made inoperable for the performance of Surveillances to be delayed for 2 hours. This change does not involve a significant reduction in a margin of safety since the allowance is only applicable for a short period of time (2 hours) provided initiation capability of one diesel generator and associated 4160 V ESS bus is maintained from the associated Function. In addition, the change does not affect current analysis assumptions. Therefore, this change does not involve a significant reduction in a margin of safety.

NO SIGNIFICANT HAZARDS CONSIDERATION
ITS: 3.3.8.2 - RPS ELECTRIC POWER MONITORING

L.1 CHANGE

In accordance with the criteria set forth in 10 CFR 50.92, ComEd has evaluated this proposed Technical Specifications change and determined it does not represent a significant hazards consideration. The following is provided in support of this conclusion.

1. Does the change involve a significant increase in the probability or consequences of an accident previously evaluated?

This change will limit the required applicability to those conditions during which the RPS electric power monitoring assemblies provide a necessary function. Although loss of power is considered in conjunction with design basis accidents, it is not considered as an initiator for any accidents previously analyzed. Therefore, this change does not significantly increase the probability of a previously analyzed accident. Also, this change does not degrade the capability of the RPS electric power monitoring assemblies to perform their design basis function when needed. Therefore, this change does not significantly increase the consequences of a previously analyzed accident.

2. Does the change create the possibility of a new or different kind of accident from any accident previously evaluated?

The proposed change does not introduce a new mode of plant operation and does not involve physical modification to the plant. Therefore, it does not create the possibility of a new or different kind of accident from any accident previously evaluated.

3. Does this change involve a significant reduction in a margin of safety?

This change does not involve a significant reduction in a margin of safety since the RPS electric power monitoring assemblies are provided to assure adequate power is available to the RPS and RPS bus powered equipment when required and this change only affects conditions where such power would not be required.

NO SIGNIFICANT HAZARDS CONSIDERATION
ITS: 3.3.8.2 - RPS ELECTRIC POWER MONITORING

L.2 CHANGE

In accordance with the criteria set forth in 10 CFR 50.92, ComEd has evaluated this proposed Technical Specifications change and determined it does not represent a significant hazards consideration. The following is provided in support of this conclusion.

1. Does the change involve a significant increase in the probability or consequences of an accident previously evaluated?

This change will provide additional time to restore inoperable RPS electric power monitor assemblies. The RPS electric power monitoring assemblies are not considered as an initiator for any accidents previously analyzed. Therefore, this change does not significantly increase the probability of a previously analyzed accident. Also, this change does not further degrade the capability of the RPS electric power monitoring assemblies to perform their required function under these circumstances. Therefore, this change does not significantly increase the consequences of a previously analyzed accident.

2. Does the change create the possibility of a new or different kind of accident from any accident previously evaluated?

The proposed change does not introduce a new mode of plant operation and does not involve physical modification to the plant. Therefore, it does not create the possibility of a new or different kind of accident from any accident previously evaluated.

3. Does this change involve a significant reduction in a margin of safety?

This change does not involve a significant reduction in a margin of safety since the extended time is small and allows for operator consideration of plant conditions, personnel availability and appropriate response.

NO SIGNIFICANT HAZARDS CONSIDERATION
ITS: 3.3.8.2 - RPS ELECTRIC POWER MONITORING

L.3 CHANGE

In accordance with the criteria set forth in 10 CFR 50.92, ComEd has evaluated this proposed Technical Specifications change and determined it does not represent a significant hazards consideration. The following is provided in support of this conclusion.

1. Does the change involve a significant increase in the probability or consequences of an accident previously evaluated?

This change will remove the requirement for OPERABILITY of the RPS electric power monitoring assemblies in MODE 5 when control rods are withdrawn from core cells containing no fuel assemblies. OPERABILITY of the RPS electric power monitoring assemblies will only be required in MODE 5 when control rods are withdrawn from core cells containing fuel assemblies. Control rods withdrawn from or inserted into a core cell containing no fuel assemblies have a negligible impact on core reactivity and Shutdown Margin (SDM). Provided all control rods otherwise remain inserted, the RPS Functions and the RPS equipment protective function provided by the RPS electric power monitoring assemblies serve no purpose and are not required. Thus, since they are not required, the RPS Functions and the RPS electric power monitoring assemblies are not considered initiators of any previously analyzed accidents. This proposed change will still require OPERABILITY of the RPS electric power monitoring assemblies when required to support the RPS Functions (ITS 3.3.1.1). Therefore, this change does not significantly increase the probability of a previously analyzed event. Furthermore, the removal of the OPERABILITY requirement for the RPS electric power monitoring assemblies in MODE 5 when control rods are withdrawn from core cells containing no fuel assemblies will have a negligible effect on core reactivity and SDM. Therefore, this proposed change will not significantly increase the consequences of an accident previously evaluated.

2. Does the change create the possibility of a new or different kind of accident from any accident previously evaluated?

The proposed change does not involve any design change or plant modifications, nor will the change alter the mode of plant operation in a manner that could create a new precursor of an accident. As such, the RPS electric power monitoring assemblies and the supported RPS equipment will continue to function as previously analyzed. Therefore, the proposed change will not create the possibility of a new or different kind of an accident from any accident previously evaluated.

NO SIGNIFICANT HAZARDS CONSIDERATION
ITS: 3.3.8.2 - RPS ELECTRIC POWER MONITORING

L.3 CHANGE (continued)

3. Does this change involve a significant reduction in a margin of safety?

This proposed change will remove the requirement for OPERABILITY of the RPS electric power monitoring assemblies in MODE 5 when control rods are withdrawn from core cells containing no fuel assemblies. The RPS electric power monitoring assemblies support OPERABILITY of the RPS Functions (ITS 3.3.1.1). This change will continue to ensure the RPS electric power monitoring assemblies are OPERABLE when required to support OPERABILITY of the RPS Functions. Furthermore, since control rods withdrawn from a core cell containing no fuel assemblies have a negligible impact on core reactivity and SDM, this change will have negligible effect on core safety margins. Therefore, this proposed change does not involve a significant reduction in a margin of safety.

NO SIGNIFICANT HAZARDS CONSIDERATION
ITS: 3.3.8.2 - RPS ELECTRIC POWER MONITORING

L.4 CHANGE

In accordance with the criteria set forth in 10 CFR 50.92, ComEd has evaluated this proposed Technical Specifications change and determined it does not represent a significant hazards consideration. The following is provided in support of this conclusion.

1. Does the change involve a significant increase in the probability or consequences of an accident previously evaluated?

This change removes the requirement to notify the NRC if required by 10 CFR 50.72 and to submit a Licensee Event Report as required by 10 CFR 50.73 if the RPS electric power monitoring assemblies are not restored to Operable status or the MG set or alternate power supply is not removed from service in MODE 5 with any control rod withdrawn from a core cell containing one or more fuel assemblies. The change replaces these requirements with specific actions that place the reactor in the least reactive condition and ensures the safety function of the RPS instrumentation will not be required. The required reports are not considered as initiators for any accidents previously analyzed. Therefore, this change does not significantly increase the probability of a previously analyzed accident. The consequences of a previously analyzed accident are not affected by the deletion of these reporting requirements since they do not impact the assumptions of any design basis accident or transient.

2. Does the change create the possibility of a new or different kind of accident from any accident previously evaluated?

The proposed change does not introduce a new mode of plant operation and does not involve physical modification to the plant. Therefore, it does not create the possibility of a new or different kind of accident from any accident previously evaluated.

3. Does this change involve a significant reduction in a margin of safety?

The margin of safety is not reduced by removing the requirement for the submittal of these required reports. This change has no effect on the assumptions of design basis accidents or transients. This change has no impact on safe operation of the plant because adequate actions are provided if the RPS electric power monitoring assemblies cannot be restored and the RPS MG set or alternate power supply cannot be removed from service. This change does not affect any plant equipment or requirements for maintaining plant equipment. Therefore, this change does not involve a significant reduction in a margin of safety.

**NO SIGNIFICANT HAZARDS CONSIDERATION
CTS: 3/4.2.H - EXPLOSIVE GAS MONITORING**

There were no plant specific less restrictive changes identified for this Specification.

**NO SIGNIFICANT HAZARDS CONSIDERATION
CTS: 3/4.2.1 - SUPPRESSION CHAMBER AND DRYWELL SPRAY ACTUATION**

There were no plant specific less restrictive changes identified for this Specification.

**NO SIGNIFICANT HAZARDS CONSIDERATION
CTS: 3/4.2.K - TOXIC GAS MONITORING**

There were no plant specific less restrictive changes identified for this Specification.

ENVIRONMENTAL ASSESSMENT
ITS: SECTION 3.3 - INSTRUMENTATION

In accordance with the criteria set forth in 10 CFR 50.21, ComEd has evaluated this proposed Technical Specification change for identification of licensing and regulatory actions requiring environmental assessment, determined it meets the criteria for a categorical exclusion set forth in 10 CFR 51.22(c)(9) and as such, has determined that no irreversible consequences exist in accordance with 10 CFR 50.92(b). This determination is based on the fact that this change is being proposed as an amendment to a license issued pursuant to 10 CFR which changes a requirement with respect to installation or use of a facility component located within the restricted area, as defined in 10 CFR 20, or which changes an inspection or a surveillance requirement, and the amendment meets the following specific criteria:

1. The amendment involves no significant hazards consideration.

As demonstrated in the No Significant Hazards Consideration, this proposed amendment does not involve any significant hazards consideration.

2. There is no significant change in the type or significant increase in the amounts of any effluents that may be released offsite.

The proposed change will not result in changes in the operation or configuration of the facility. There will be no change in the level of controls or methodology used for processing of radioactive effluents or handling of solid radioactive waste, nor will the proposal result in any change in the normal radiation levels within the plant. Therefore, there will be no change in the types or significant increase in the amounts of any effluents released offsite resulting from this change.

3. There is no significant increase in individual or cumulative occupational radiation exposure.

The proposed change will not result in changes in the operation or configuration of the facility which impact radiation exposure. There will be no change in the level of controls or methodology used for processing of radioactive effluents or handling of solid radioactive waste, nor will the proposal result in any change in the normal radiation levels within the plant. Therefore, there will be no increase in individual or cumulative occupational radiation exposure resulting from this change.

Therefore, based upon the above evaluation, ComEd has concluded that no irreversible consequences exist with the proposed change.