



DEPARTMENT OF MECHANICAL ENGINEERING
THE UNIVERSITY OF TEXAS AT AUSTIN

Nuclear Engineering Teaching Laboratory • (512) 232-5370 • FAX (512) 471-4589

January 20, 2000

Nuclear Regulatory Commission
Attn: Document Control Desk
Washington D.C., 20555

Subject: The University of Texas Reactor Reflector

Reference: Docket 50-602

Dear Sir:

Attached for your consideration is a report on the Nuclear Engineering Teaching Laboratory Reflector. It has been reviewed and approved by the UT Reactor Committee. Please contact me if you require any additional information at 512-232-5373.

Sincerely,

A handwritten signature in cursive script that reads "Sean O'Kelly".

Sean O'Kelly
Associate Director

xc: A. Adams, Project Manager, NRC
P. Perez, TRTR Chairman

I. Introduction

The University of Texas at Austin (UT) has reported to the NRC (12/16/99) an unusual condition associated with the annular graphite Reflector surrounding the Nuclear Engineering Teaching Laboratory (NETL) TRIGA[®] reactor. The aluminum container that encapsulates the graphite showed signs of bulging or swelling. Further, during an investigation of this occurrence, bubbles were detected coming from a weld in the aluminum. This report summarizes the results of the UT investigation and provides a conclusion as to the probable cause of this condition and the actions UT will take to correct the problem and resume safe operation. The Organization of Test, Research and Training Reactors (TRTR) has responded to a request for assistance by UT.

II. Background

The Reflector is an annular, machined block of graphite canned or encapsulated in 0.25, 0.5 and 0.625 inch welded Alloy 6061 aluminum plate. The welds are tested using dye penetrant methods and helium leak tests during manufacturing. The manufacturer has been unable to locate certification paperwork for the final helium leak test but the test was signed off as being performed on the inspection documentation. The weld and approximate leak location is shown in Figure 1.

The first indication of the problem was bulging or swelling of the Reflector as indicated by movement of the Rotary Specimen Rack (RSR) drive shaft upwards approximately 0.25 to 0.5 inch and noted in late October. Measurements compared to original installation data confirmed the top of the Reflector had moved upwards. Other measurements taken confirmed that the pool floor and neutron beam tubes had not moved. The Reactor Safety Committee (RSC) was informed of these unusual conditions during a scheduled meeting on October 25 1999. A special subcommittee of the RSC has been formed to monitor and provide review of the NETL corrective actions. This subcommittee has met several times and had conference phone calls to review any new information. In addition, the University Radiation Safety Committee has been informed.

On October 28 1999, a Pneumatic Transfer Tube was found stuck in the outer ring of the reactor grid plate, but was removed with minimum effort. Visual inspections indicated that bulging of the inner wall of the reactor Reflector had caused binding of the pneumatic transfer tube experimental device. After removing core fuel, further visual inspections revealed bulges or swelling of several large plates forming the inner wall of the Reflector. Four non-fuel graphite elements were also found to be binding. All graphite and fuel elements were removed intact from the reactor core area. The locations of the graphite elements, pneumatic tube and approximate bulge locations are shown in Figure 2. The NRC and General Atomics (GA) were notified of the unusual circumstances and the continuing investigation. On December 12 1999, the TRTR community was formally requested to assist in resolving this issue.

Repeatable (in size and location but spread in time) bubbles at a rate of one release per 1.5 hours were eventually noticed while unloading the fuel from the reactor. At this point, it became clear

there had been a failure of the Reflector outer boundary allowing a water leakage into the system and gas venting.

III. Analysis of Gas

Several bubbles were captured in a funnel and flask system to determine the gases in the Reflector. The first test was a crude flame test to see if the gases would ignite. The gas sample extinguished a flame with no indications of combustion. Several more gas samples were captured to determine the leak rate (~30 ml/hour) and for analysis. One sample was checked with a toxic gas meter (used for entering confined spaces) and indicated high concentrations of Hydrogen, Oxygen and Hydrocarbons when the meter pegged off scale, but the concentrations and components eventually determined with the meter were inconclusive. Samples were sent to a local company (TRI in Austin, Texas) on 11/30/99 for Gas Chromatography and to the UT Chemistry department for Mass Spectroscopy.

The Gas Chromatography results were

Hydrogen	Nitrogen	Oxygen	Carbon Dioxide	Methane	Carbon Monoxide
64%	5%	30%	920 ppm	16 ppm	245 ppm

The Mass Spectroscopy results also indicated elevated levels of Oxygen and Hydrogen. The low levels of CO and CO₂ may indicate some oxidation of the graphite, perhaps by ozone, but in amounts insignificant to the overall pressure increase. Some minor contamination of the sample with air absorbed in the pool water may be present.

NETL staff concluded that the mixture might ignite under certain (although unlikely) conditions and that the total volumes exceeded the limits allowed by Technical Specification 3.4.2.c, Limits on Experiment Materials. The NETL staff acknowledges that Specification 3.4.2.c does not explicitly address the Reflector or this particular condition because the Reflector is considered a sealed system and the Reflector is not considered an experiment or experiment location.

The gas volume in the Reflector was calculated to be approximately 41 liters by simple subtraction of the apparent graphite volume from the volume enclosed by the aluminum housing. The pressure in the Reflector was assumed to be in equilibrium with the pressure of the tank (20 foot depth) at 1.6 atmospheres. This yielded, by the Ideal Gas law and the above analysis, approximately 4 grams of hydrogen. This is a conservative estimate because the volume occupied by water is not included.

The change in enthalpy for the reaction of hydrogen and oxygen to produce liquid water is -286 kJ/mole which was divided by two to consider hydrogen as the only reactant. Finally, the conversion of 104 joules per 25 mg of TNT was taken from the NETL SAR and Technical Specifications.

(4 grams Hydrogen)(143 kJ/mole)(1 mole Hydrogen/1 gm)

104 joules/25 mg TNT

The result (137.5 g TNT) was an initial calculation that indicated the NETL might have exceeded the 25 mg limit by at least 5500 times in the unlikely event the mixture were to completely ignite. However, the actual yield rarely exceeds 10% of the theoretical yield. The amount of gas and the estimated equivalence were reported to the NRC.

Later calculations resulted in higher internal pressures to account for the deformation of the aluminum Reflector. Dr. Karl Frank of the UT Department of Civil Engineering calculated it would take approximately 200 psi to cause the displacements in the 0.25 inch aluminum plate. Calculations using this pressure and an equivalence provided by a 1987 EPRI report on Hydrogen Water Chemistry (1000 scf H₂ = 27.1 lbs TNT, EPRI 1987) would make the total Hydrogen fuel material to be 155 gms of TNT equivalent if there were complete combustion. There is no risk of fuel related problems since the fuel has been removed from the reactor pool and is stored in a separate location.

IV. Postulated Causes of Pressure Buildup

Many possible scenarios were evaluated to explain the Reflector swelling (total flooding, graphite growth, etc). The following are considered to be possible causes based on indications provided by visual and ultrasonic testing and consultations with members of the TRTR community.

Ultrasonic testing performed on November 17 1999 did not indicate a discernable water level in the Reflector. Past flux measurements in the Beam Ports and the RSR have not indicated severe losses of neutrons due to absorption as would be expected from complete flooding. There had been indications of an unexplainable slight decrease in neutron flux at the Reactor Power Channel detectors during the first four years of operation (1992-1996). These decreases were noticeable but within allowed tolerances. These changes were noted during annual power calibrations and investigated. A cause was never found and no decrease in indicated power has been observed since 1996. These indications would support the theory of a small water leak into the interior of the Reflector allowing the graphite to absorb water over time.

1. Galvanic Cell and Electrolysis

Ultrasonic tests of the Reflector did not indicate large-scale galvanic corrosion was occurring. However, the necessary conditions appear to exist within the Reflector to establish an electrochemical cell. Similar to the common Carbon-Zinc battery sold commercially, the electric potential between the aluminum anode and the graphite cathode would provide an electromotive force to drive an internal electrolysis cell. The production of gas from electrolysis is a function of the current flowing and it appears possible to produce significant quantities of gas at low currents over a long period. This reaction requires an electrolyte for current flow and may continue to build gas pressure or compensate for leakage until the system is vented and flushed with deionized water from the reactor pool.

Approximate Electrochemical Cell Potential

Half-Reaction for Oxidation of Aluminum	E^0 (V)
$Al^{3+} + 3e^- \leftrightarrow Al$	-1.66

Electrolysis reactions of water under an applied potential

Half-Reaction	E^0 (V)
(Cathode) $2 H_2O + 2 e^- \rightarrow H_2 + 2 OH^-$	-0.83
(Anode) $2 H_2O \rightarrow O_2 + 4 H^+ + 4 e^-$	-1.23

The water used in the reactor pool is essentially deionized water with low conductivity. The NETL staff believes the low conductivity would prevent gross galvanic corrosion and inhibit electrical conduction. Impurities in the graphite leaching into the water and concentrating could provide the ions necessary for current flow. The aluminum oxide layer is particularly resistant to chemical attack and is often used as an electrical insulator; however, minor damage (scratches or thin areas) to the alumina (Al_2O_3) layer could provide an electrical current path. Ultrasonic testing of several regions of the Reflector confirmed that the aluminum plates were the design thickness with no indications of large-scale galvanic corrosion.

2. Radiolysis of Water

The effects of radiation on water and water vapor has been extensively studied and the predominate primary process of radiolytic decomposition has been found to be

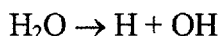

In systems with a large free volume or when water vapor is irradiated, the gaseous products (O_2 and H_2) may escape recombination by diffusion and be removed from the back reactions that would reform water. In effect, the water is decomposed by radiation under these particular conditions. The final H_2 to O_2 ratio is not expected to be 2:1 and the total quantities produced are expected to be low. In general, long-term radiolysis of pure water does not produce stoichiometric quantities of O_2 and H_2 (ratios in pure water for low LET radiation are on the order of 10:1, $H_2:O_2$) but may approach the 2:1 ratio given sufficient air space and long irradiation times (Spinks 1990, Allen 1961, Farhataziz and Rogers 1987). Without exception, the professional Radiation Chemists contacted in the preparation of this report were surprised at the high pressures, the approximately 2:1 ratio of gases and the low concentrations of oxides of carbon. This supports the hypothesis that the possible primary cause of the gas buildup was electrolysis of water.

V. Gas Mixture Reactions

The NETL TRIGA Reflector is currently in a stable condition. The interior is assumed to have a high relative humidity and the conductive Reflector aluminum is grounded to the pool liner through the support structure. All unnecessary electrical equipment has been turned off near the reactor pool. The reactor fuel was removed from the core in early November 1999 and moved out of the pool to storage in late December 1999.

The concentrations of gases within the Reflector may react and chemically combine if an ignition source is provided. However, an energetic source of initiation is required for a rapid combustion reaction. The comparison between TNT as a point source and a H_2+O_2 mixture must be done carefully. TNT produces a short duration, high-impulse pressure wave from rapid expansion of a point source of gases, but H_2+O_2 reactions will have a longer duration and lower impulse pressure. The H_2+O_2 combustion is propagated due to a traveling compression wave heating the gases above the autoignition ($\sim 550^\circ C$ for H_2+O_2) temperature. The gases within the Reflector are not in a single volume but are contained in smaller, interconnected volumes. The environment of the combustion (temperature, pressure, and the walls of reaction area) has a significant effect on the rate of reaction, velocity and the propagation of the reaction. The addition of water vapor to the gas mixture will tend to prevent initiation and will limit the resulting peak pressures when ignited (Jost 1946). An addition of 10, 20, and 30% of steam to a stoichiometric H_2 -Air mixture reduces the ignitability of the gases by raising the energy necessary to ignite by a factor of 220, 2.7E4 and 2.2E5, respectively (Baker 1991). Peak pressure from dry H_2+O_2 combustion under laboratory conditions is approximately 18-20 times the initial pressure (Jost 1946, Ordin 1957). It is unlikely that ignition will occur under the conditions present in and around the Reflector.

VI. Venting the Reflector

Electrolysis gas production will continue until the ions allowing current flow are flushed from the system. It is important to expedite the venting of the gas pressure on the Reflector Assembly and relieve the strain on the aluminum walls. The NETL staff has consulted with experienced local machinists and outside agencies (NIST, NASA, Sandia National Laboratories) to determine an optimum venting method that will not cause gas ignition. Gas ignition is unlikely because high heat and sparking are necessary. The Reflector conditions (wet, cool) and materials (aluminum) will minimize the probability of gas ignition while venting.

Venting will be performed at full pool depth (25 feet) for maximum personnel safety and will result in the Reflector flooding. Operation of the NETL Reactor with a flooded reflector will be evaluated separately under 10 CFR 50.59. The venting method will not produce high local heating, rapid decompression or result in sparks from static charges. Options for venting are limited due to the depth of the pool and the difficulty in manipulating tools from a large distance.

The NETL staff, with direct assistance of expert machinists, intends to drill a small vent hole through the upper Al plate. The drilling will be performed using a long (25+ foot) shaft. The drill will be aligned and the vented gases controlled by using a system similar to Figure 3. This system avoids the necessity of drilling and tapping a larger hole to accommodate a valve or threaded connection. NETL staff are consulting with groups of experienced machinists to determine the best method to accomplish the venting task and the method used will be reviewed and approved by the UT Reactor Committee.

The drill bit or other device, such as a milling tool, will be operated slowly using a remotely operated milling machine or drill press. Following successful penetration, the Reflector will be allowed to equalize pressure by venting through the reactor pool water. After the Reflector pressure has decreased sufficiently, the original drilling tool will be replaced with a larger tool to

allow complete venting and initial flooding of the Reflector interior. Several holes will be eventually drilled in the reflector cladding to avoid gas spaces and allow coolant flow through the reflector. Provisions will be carefully considered for gas collection or dilution and radiation protection (airborne contamination) of the workers.

VII. Summary

The Reflector contains a mixture of hydrogen and oxygen that should be vented as soon as possible to minimize the negative effects on the Reflector assembly. There are no ignition sources present within the Reflector and the system is in a stable condition but gas production may be continuing by electrolysis. The reactor fuel and all significant radioactive material have been removed from the reactor pool so there is no danger of release of radioactive material in the unlikely event that the gas were ignited.

The probability of combustion from drilling is negligible because:

1. There is no ignition source
2. Aluminum is readily machinable and does not generate work heat
3. 25 feet of water is present for cooling and lubrication

The consequences of combustion from drilling are negligible because

1. The aluminum activity has decayed
2. The fuel has been removed from the reactor pool
3. There is negligible contamination in the pool water

Accordingly, the Reflector can be vented with no risk. Procedures will be developed to allow venting in a controlled and safe manner. These procedures will be carefully reviewed by internal and external advisors and approved by the UT Reactor Committee prior to implementation. Operation of the reactor with the Reflector flooded will be evaluated under 10CFR50.59 prior to returning to normal operations.

References:

- Allen, A. O. (1961), "The Radiation Chemistry of Water and Aqueous Solutions", D. Van Nostrand Company, Inc.
- Anderson, A.R. (1968), "Fundamental Processes in Radiation Chemistry", Ed P. Ausloss, Interscience. Chapter 5 "Inorganic Gases".
- Baker, W.E. and Tang, M.J. (1991), "Gas, Dust and Hybrid Explosions", Elsevier Science Publishers
- Brand, Paul C. NIST Center for Neutron Research, personal communication with S. O'Kelly
- Elliot, A. J. (1994), "Rate Constants and G-Values for the Simulation of the Radiolysis of Light Water over the Range 0-300°C", AECL-11073, COG-94-167
- Elliot, A. J. (1999), Personal correspondence with S. O'Kelly
- Electric Power Research Institute (EPRI) 1987, "Guidelines for Permanent BWR Hydrogen Water Chemistry Installations-1987 Revision", EPRI-NP-5283-SR-A, Special Report, September 1987
- Farhataziz and Rodgers, M.A.J. (1987), "Radiation Chemistry: Principals and Applications", VCH Verlagsgesellschaft mbH.
- Gray, W.J. and McVay, G.L. (1985), " Nitric Acid Formation during Gamma Irradiation of Air/Water Mixtures", Radiation Effects **89**, 257-262.
- Haines, R.I., McCracken, D.R.. and Rasewych J.B. (1989), "Decomposition of Hydrogen Peroxide under CANDU Coolant Conditions", Water Chemistry of Nuclear Reactor Systems 5. Vol. 1, BNES.
- Icenhour, A. S. , Member of Chemical Technology Division at ORNL, personal communication with S. O'Kelly
- Jost, W. (1946), "Explosion and Combustion Processes in Gases", McGraw-Hill Book Company, Inc.
- Karasawa, H., Ibe, E., Uchida, S, Etoh, Y. and Yasuda, T. (1991), "Radiation Induced Decomposition of Nitrogen", Radiat. Phys. Chem. **37**, 193-197.
- Lee, F.W., Collins, C.B. and Walker, R.A. (1976), "Measurement of the Rate Coefficients for the Bimolecular and Termolecular Charge Transfer Reactions of He²⁺ with Ne, Ar, N₂, CO, CO₂ and CH₄", J. Chem. Phys. **65**, 1605-1615.

Lewis, B. and von Elbe, G. (1961), "Combustion, Flames and Explosions of Gases", 2nd Edition, Academic Press Inc.

Ordin, P. M. (1957), "Hydrogen-Oxygen Explosions in Exhaust Ducting", National Advisory Committee on Aeronautics, Technical Note 3935, Lewis Flight Propulsion Laboratory

Powers, D. A., Chairman of NRC ACRS and Senior Scientist at Sandia National Laboratory, personal communication with S. O'Kelly

Reed, D.T. and R.A. Van Konynenburg (1987), "Effect of Radiation on Moist Air Systems", Lawrence Livermore National Laboratory Report ECRL-97936.

Spinks, J.W.T. and Woods, R.J. (1990), "Introduction to Radiation Chemistry", 3rd Edition, Wiley Interscience.

"Safety Standard for Hydrogen and Hydrogen Systems", NASA Office of Safety and Mission Assurance, NSS 1740.16

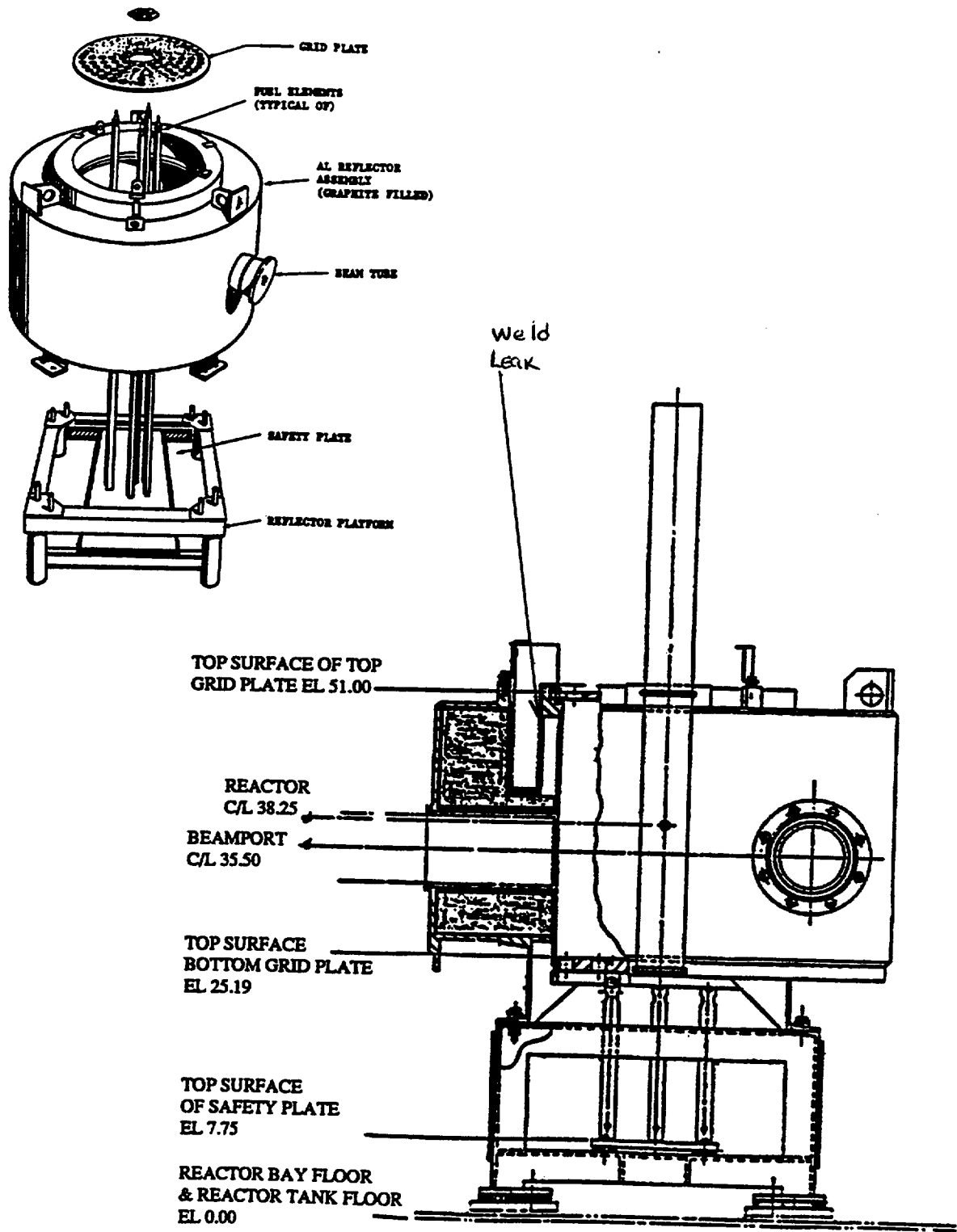

TRIGA reactor - elevation view

REACTOR, REFLECTOR, AND SHIELDING

Figure 1

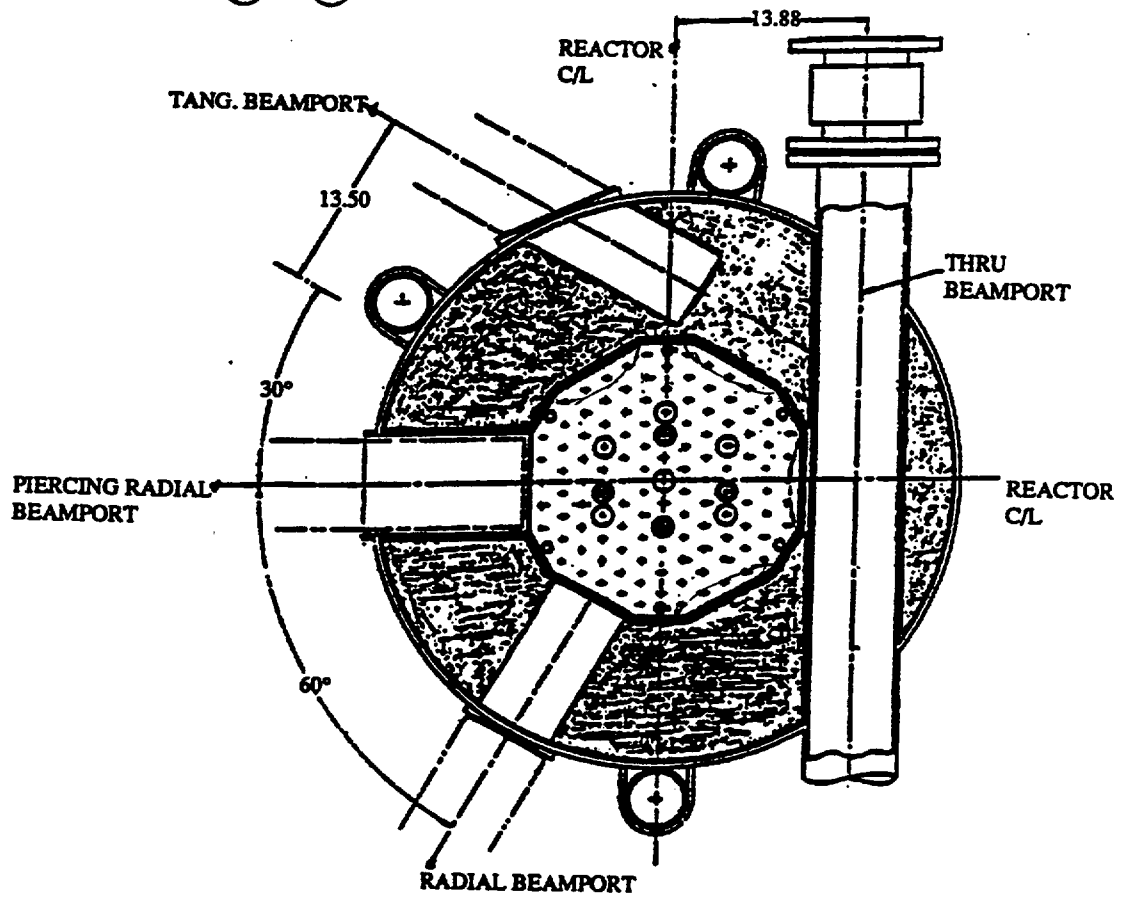
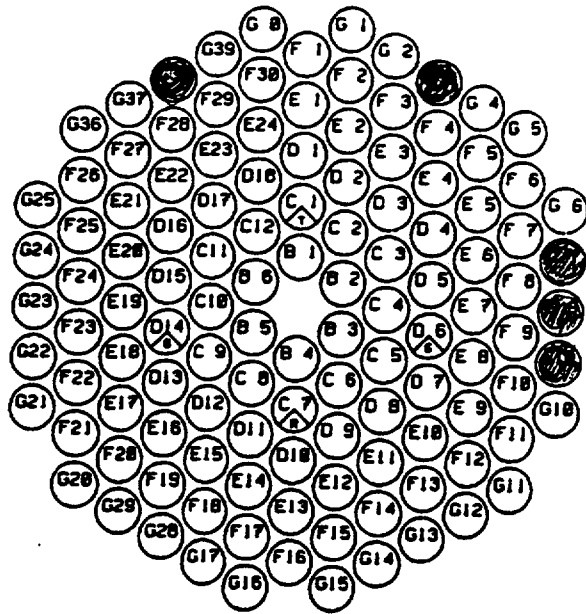

TRIGA reactor - cross section through beamports

CORE ARRANGEMENT

Figure 2

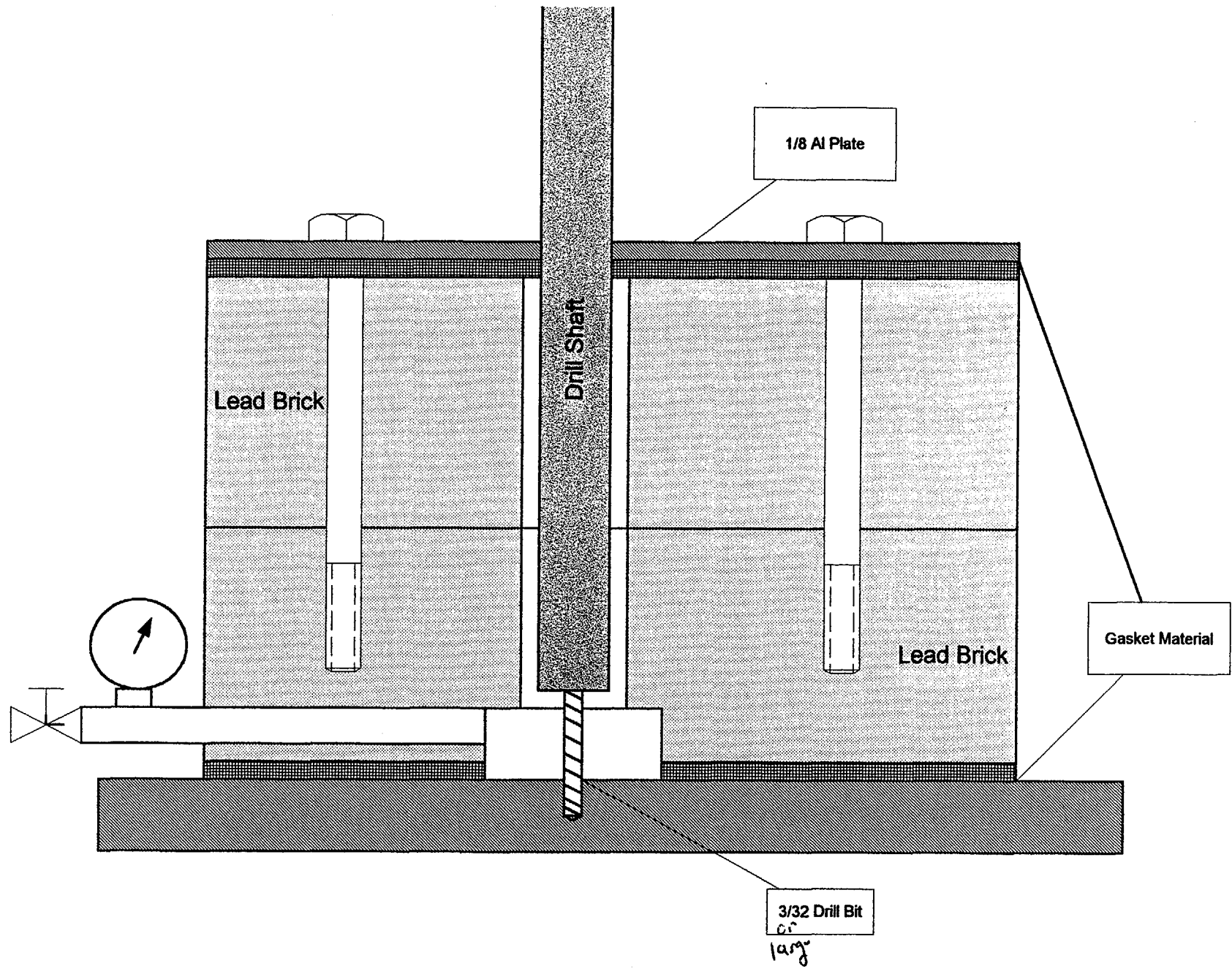

Figure 3